



Preferred Service

# Service Manual

This manual is to be used by qualified appliance technicians only. Viking does not assume any responsibility for property damage or personal injury for improper service procedures done by an unqualified person.

## Built-In Side by Side Non-Dispenser Refrigerator / Freezer

This Base Manual covers general and specific information including, but not limited to the following models:

**FDSB5421**  
**FDSB5481**  
**VCSB5421**  
**VCSB5481**



SMR-0020  
MAY 2012

# Table of Contents



Important Information	3	Program Mode A	30
Safety Information	3	Display Ref Temperature	30
Warnings	4	Display Frz Temperature	30
Electrical Requirements	4	Defrost mode selection	30
Tip Over Hazard	4	Conventional defrost time adjustment (CRTD)	30
General Information	5	Compressor low speed frequency	31
Model - Serial Number Matrix	5	Adjust Cut-In Hysteresis	31
Operation	6	Adjust Cut-Out Hysteresis	32
Settings and Functions	6	Display Software Version	33
Electronic Temperature Settings	6	Exiting Mode A	33
Electronic Temperature Settings	6	Program Mode B	34
Key Press Confirmation	6	Adjust Freezer Temperature Offset	34
Fast Cool	7	Adjust Refrigerator Temperature Offset	34
MAX FRZ	7	Adjust MAX FRZ duration	35
MAX REF	7	Adjust MAX REF duration	35
Forced Pull-Down (Forced compressor start)	8	Adjust FAST COOL duration	35
Forced Defrost	8	Adjust Door Open Alarm delay	36
Showroom Mode	9	Adjust Compressor Dwell Time	36
Sabbath Mode	9	Adjust Compressor High Frequency	36
Fahrenheit to Celsius	9	Adjust DC Fan Cycling On Time	36
Display Panel Operation	10	Adjust DC Fan Cycling Off Time	36
Temperature Control Operation	11	Exiting Mode B	36
Disassembly	12	Program Mode C	37
Parts Location—Control Panel	12	Set Model type	37
Upper Grille Assembly	13	Adjust Freezer Upper Temperature Limit	37
Control Panel	13	Adjust Freezer Lower Temperature Limit	37
Control Panel (continued)	14	Adjust Refrigerator Upper Temperature Limit	38
Overlay Switch	14	Adjust Refrigerator Lower Temperature Limit	38
Overlay Switch (continued)	15	Defrost lockout adder	38
High Voltage Board	15	Defrost start delay	39
Low Voltage Board	15	Defrost termination delay	39
Power Disconnect Switch	16	Constant Evaporator fan mode	39
Inverter	16	Plant mode	39
Inverter (continued)	17	ALARMS	40
Condenser Fan	17	1. High Temp Alarm	40
Parts Location—Refrigerator Compartment	18	2. Open Thermistor Alarm	40
Light Assembly	19	3. Shorted Thermistor Alarm	41
Fresh Food Fan Assembly	19	4. Power Loss Alarm	41
Interior Lights	20	5. Door Open Alarm	41
Plasma Cluster™	20	TABLE 1 - Model types	42
Parts Location—Freezer Compartment and Lower Unit—Non Dispenser	21	Door Stop Adjustment	43
Ice Maker (shown here with cover off)	22	Light Bulb	43
Thermal Cut Out (TCO)	25	Door Hinge Adjustment	43
Freezer Evaporator Fan	25	Height Adjustment	44
Freezer Thermistor	26	Diagnostics	46
Defrost Heater	26	VCC3 Inverter Diagnostic Codes	46
Defrost Terminator	28	High Voltage Board	47
Float Switch	28	Low Voltage Board	48
Water Valve	29	Troubleshooting Guide	49
Drain Pan Heater	29	Wiring Diagrams	52
Service Procedures	30	Wiring and Component Testing	52
Program Modes	30	High Voltage Board	52
		Side by Side schematic	53
		Side by Side Wiring Diagram	54

## SAVE THESE INSTRUCTIONS

**REVIEW ALL SERVICE INFORMATION IN THE APPROPRIATE SERVICE MANUAL AND TECHNICAL SHEETS BEFORE BEGINNING REPAIRS.**

Pride and workmanship go into every product to provide our customers with quality products. It is possible, however, that during its lifetime, a product may require service. Products should be serviced only by a qualified service technician that is familiar with the safety procedures required in the repair and who is equipped with the proper tools, parts, testing instruments, and the appropriate service manual.

### Safety Information

We have provided many important safety messages in this manual and on the appliance. Always read and obey all safety messages. This is the safety alert symbol.



This symbol alerts you to hazards that can kill or hurt you and others. All safety messages will be preceded by the safety alert symbol and the word "DANGER", "WARNING", or "CAUTION". These words mean:

DANGER

**IMMEDIATE HAZARDS WHICH WILL RESULT IN SEVERE PERSONAL INJURY OR DEATH.**

WARNING

Hazards or unsafe practices which COULD result in severe personal injury or death.

CAUTION

Hazards or unsafe practices which COULD result in minor personal injury or product or property damage.

All safety messages will identify the hazard, tell you how to reduce the chance of injury, and tell you what can happen if the instructions are not followed.

WARNING

To avoid risk of serious injury or death, repairs should not be attempted by unauthorized personnel.

CAUTION

VIKING will not be responsible for any injury or property damage from improper service procedures. If performing service on your own product, you must assume responsibility for any personal injury or property damage which may result.

Technical support for authorized servicers:

1-800-914-4799

Address your written correspondence to:

Viking Preferred Service  
 1803 HWY 82 West  
 Greenwood, MS 38930

## Warnings

Read and follow all instructions before using this appliance to prevent the potential risk of fire, electric shock, personal injury, or damage to the appliance as a result of improper usage of the appliance. Use appliance only for its intended purpose as described in this manual.

To ensure proper and safe operation: appliance must be properly installed and grounded by a qualified technician. DO NOT attempt to adjust, repair, service, or replace any part of your appliance unless it is specifically recommended in this manual. All other servicing should be referred to a qualified servicer.

Make sure that incoming voltage is the same as unit rating. An electric rating plate specifying voltage, frequency, wattage, amperage, and phase is attached to the product.

## Electrical Requirements

Assure that the electrical installation is adequate and in conformance with the National Electrical Code, ANSI/NFPA 70-latest edition or Canadian Electrical Code C22.1-1998 and C22.2 No. 0-M91 (or latest edition), and all local codes and ordinances. A 115 volt, 60-Hz, 15 amp, fused, electrical supply is required. It is required that

a separate circuit serving only this appliance be provided. This appliance is equipped with a power supply cord having a 3-prong grounding plug.

To minimize possible shock hazard, the cord must be plugged into a mating 3-prong, grounding-type wall receptacle. DO NOT use an extension cord.

## Tip Over Hazard

Most of the unit's weight is at the top. Extra care is needed when moving the unit to prevent tipping. Keep doors closed until appliance is completely installed and secured per installation instructions. Use two or more people to move and install appliance. Failure to do so can result in death or serious injury.



### WARNING

#### TIP OVER HAZARD

Appliance is top heavy and tips easily when not completely installed. Keep doors closed until appliance is completely installed and secured per installation instructions. Use two or more people to move and install appliance. Failure to do so can result in death or serious injury.



### WARNING

#### ELECTRICAL SHOCK HAZARD

Disconnect power or turn power disconnect switch to "OFF" position before removing top grille. Failure to do so can result in death or electrical shock.



### WARNING

#### ELECTRICAL SHOCK HAZARD

Plug into a grounded 3-prong outlet. If a 2-prong wall receptacle is encountered, contact a qualified electrician.  
DO NOT remove ground prong. Unit must be grounded at all times. DO NOT use an adapter. DO NOT use an extension cord.  
Failure to follow these instructions can result in death, fire, or electrical shock.



### WARNING

#### BURN HAZARD

DO NOT touch condenser coils near defrost pan. Doing so can result in burns.

## Model - Serial Number Matrix

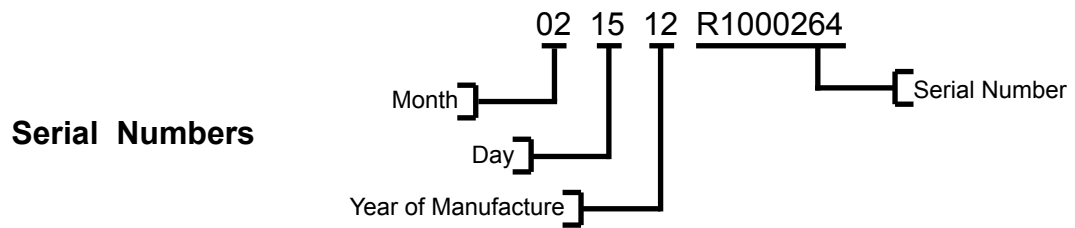
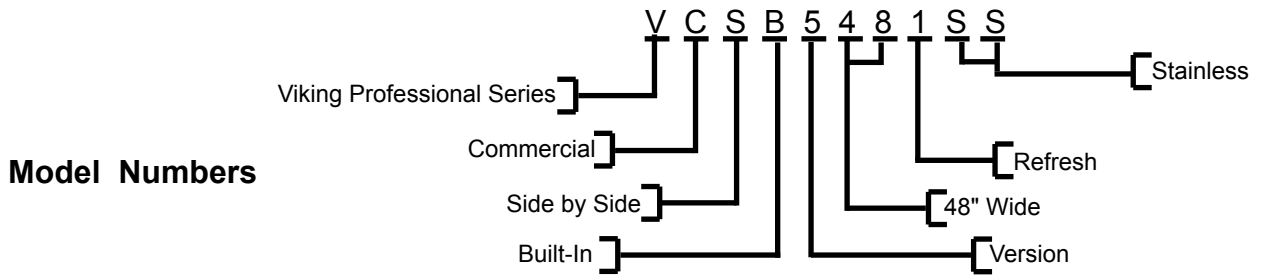

The serial number and model number for your appliance are located on the identification plate mounted on the upper left side of the door opening.

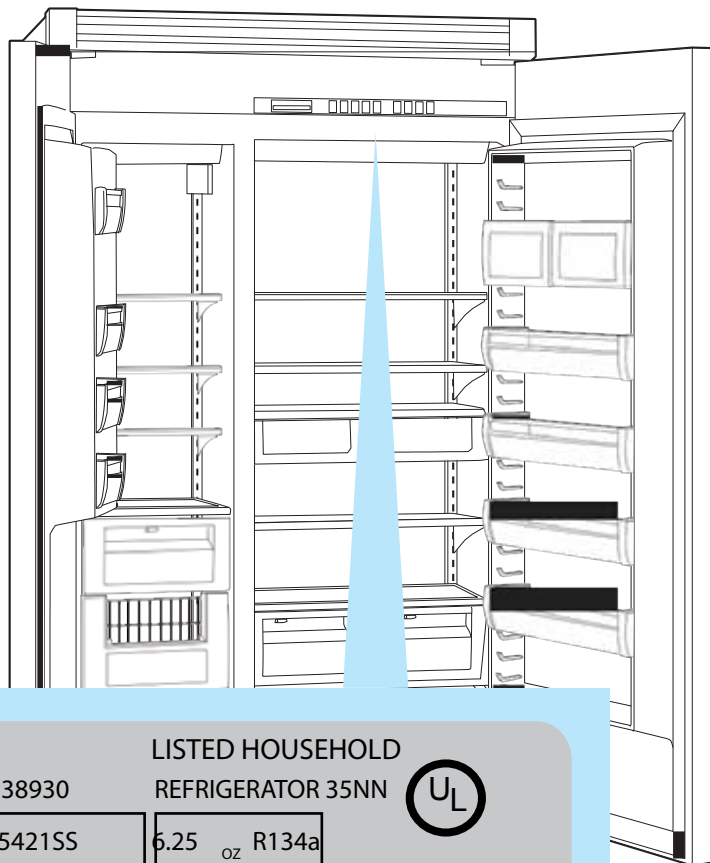

VIKING RANGE CORP. GREENWOOD, MISSISSIPPI 38930		LISTED HOUSEHOLD REFRIGERATOR 35NN	
MODEL/MODELE NUMBER/NUMERO	FDSB5421SS	6.25 oz R134a	
SERIAL/SERIE NUMBER/NUMERO	021512R10000264	115 VAC/60 HZ	
PE920095		AMPS: 9.9	

## Settings and Functions

**Power On/Off Switch (Power Interruption Switch)** The power on/off switch is located behind your refrigerator's top grille. It is used to turn the power "OFF" when cleaning the refrigerator or changing the light bulbs. Your refrigerator arrives from the factory with the power interruption switch "ON".

To turn power "OFF", remove the center grille blade. Press the power on/off switch to the "OFF" position.

To turn power "ON", press power on/off switch to the "ON" position. Replace the center grille blade.

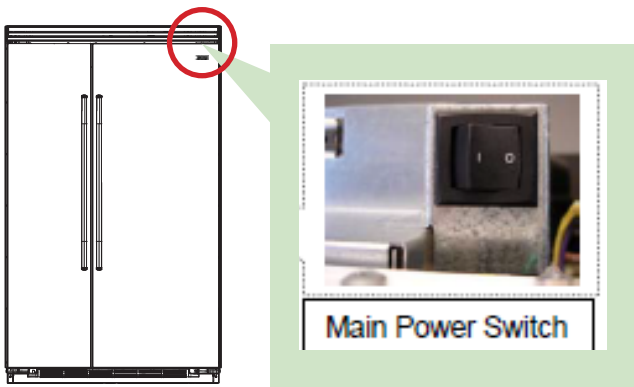

**IMPORTANT:** Be sure the power on/off switch is in the "ON" position after cleaning or changing light bulbs.

## Electronic Temperature Settings

Your refrigerator's electronic controls are located behind the door above the cabinet interior. To activate the electronic control panel, press "ACTIVATE CONTROLS" pad. All other pads, except the "Alarm Off" pad, will remain inactive until the "ACTIVATE CONTROLS" pad is pressed. Once activated, pad remains programmable for at least ten minutes



## Electronic Temperature Settings

When power is first applied to the refrigerator, there will be two dashes displayed as in illustration.

After approximately thirty seconds the digital display will change to numbers, indicating temperature in the refrigerator (default upon initial start-up) compartment along with the word REFRIGERATOR and degrees Fahrenheit.

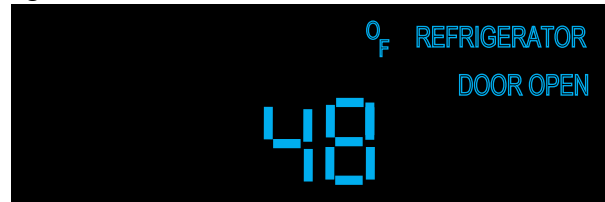

To adjust temperature, enable the key pad controls by pressing and releasing the "ACTIVATE CONTROLS" pad. Select "REF TEMP" or "FRZ TEMP" pad for applicable section. The temperature is then adjusted in that section by pressing "HIGHER" or "LOWER" pad while observing digital readout.



## Key Press Confirmation

The key press confirmation is the "beep" that is heard when a control pad is pressed. This audible confirmation can be made active or inactive.

To deactivate the confirmation beep press and hold "ACTIVATE CONTROLS" pad for three seconds, three long beeps will be heard, confirming deactivation.



To activate the confirmation beep press and hold "ACTIVATE CONTROLS" pad for three seconds, three long beeps will be heard, confirming activation.

## Fast Cool

Fast Cool is enabled by pressing and releasing the "ACTIVATE CONTROLS" pad and then pressing and releasing the "FAST COOL" pad.



This causes the control to temporarily (predetermined time, factory default is 2 hours) replace the freezer setpoint to Max Frz temperature (factory default -5° F) and also the refrigerator setpoint to Max Ref temperature (factory default 33° F).

Max Frz time duration is adjustable in Program Mode B, range is 1 to 20 hours in 1 hour increments.

The only temperature speed used during this mode of operation is high speed (115HZ).

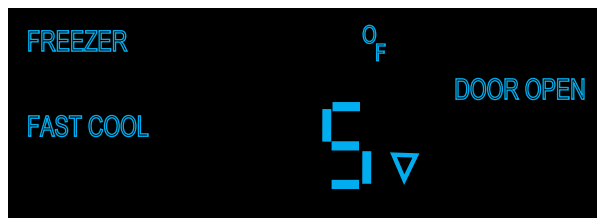

When "FAST COOL" is selected by pressing the pad, "FAST COOL" is illuminated on the display as shown in illustration above.

Fast Cool will terminate after the time duration has expired or if another mode is selected or if temperature is increased or decreased by pressing "HIGHER or LOWER" tabs. Fast Cool can be cancelled by pressing "FAST COOL" again, the Fast Cool will extinguish on the display.

## MAX FRZ

Max Frz is enabled by pressing and releasing the "ACTIVATE CONTROLS" pad and then Pressing



and releasing the "MAX FRZ" tab.



This causes the control to temporarily (factory setting is 6 hours) change the current freezer set point to -5° F. This set point temperature is not adjustable and is programmed from factory.

The time duration is adjustable in Program Mode B, range is 1 to 20 hours in 1 hour increments.

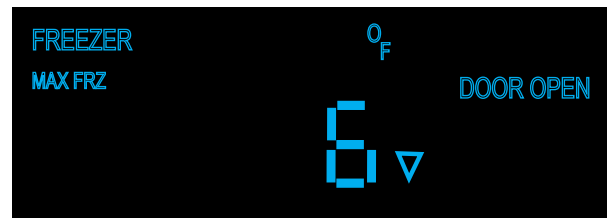

When MAX FRZ is selected, the display illuminates "MAX FRZ" as shown above. The temperature display will move towards that set point temperature (- 5° F) as the unit pulls down.

Max Frz will terminate at the conclusion of the time duration or if another mode is selected, or if the temperature is manually changed by pressing "HIGHER or LOWER" tabs. Max Frz can also be terminated by again pressing and releasing "MAX FRZ".

The conclusion or termination of this mode is confirmed by "MAX FRZ" extinguishing from display.

## MAX REF

Max Ref is enabled by pressing and releasing the "ACTIVATE CONTROLS" pad and then Pressing and releasing the "MAX FRZ" tab.



This causes the control to temporarily (factory setting is 4 hours) change the current refrigerator set point to 33° F.

This set point temperature is not adjustable and is programmed from factory.

The time duration is adjustable in Program Mode B, range is 1 to 20 hours in 1 hour increments.



When MAX REF is selected, the display illuminates "MAX REF" as shown above. The temperature display will move towards that set point temperature (33° F) as the unit pulls down.

Max Ref will terminate at the conclusion of the time duration or if another mode is selected, or if the temperature is manually changed by pressing "HIGHER or LOWER" tabs. Max Ref can also be terminated by again pressing and releasing "MAX REF".

The conclusion or termination of this mode is confirmed by "MAX REF" extinguishing from display

## Forced Pull-Down (Forced compressor start)

To enter Forced pull-down, first press and release "ACTIVATE CONTROLS", then press and hold "LOWER" pad, then press and hold "DISPLAY OFF" pad also until you get an audible consisting of three beeps.



This causes the control to immediately energize the appropriate outputs in an effort to reach both of the cut-out temperatures (refrigerator and freezer).

This function will ignore compressor dwell time and cause immediate compressor start up in the high speed mode (115HZ).

Forced pull-down will terminate after both cut-out temperatures are met, or if a defrost or forced defrost is initiated, or if an extended power loss occurs.

## Forced Defrost

To enter Forced defrost, first press and release "ACTIVATE CONTROLS", then press and hold "HIGHER" pad, then press and hold "DISPLAY OFF" pad until you get an audible consisting of three beeps.

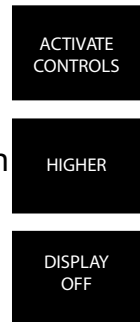

This causes the control to immediately suspend all temperature control operations and start a defrost cycle, regardless of compressor dwell time and defrost start delay.

If defrost terminator temperature is satisfied defrost heaters will come on at this time for a normal defrost cycle.

Forced defrost will terminate when defrost terminator opens (completion of cycle defrost) or if forced pull-down is initiated or if there is a long power loss..



When forced defrost is initiated the temperature numbers are replaced with "dEF" in the seven segment displays, as shown above. When defrost is complete the displayed "dEF" will again be replaced with displayed temperature numerals.



## Showroom Mode

Showroom mode allows electronic controls and interior lights to function independently of the refrigeration system.



To enter Showroom mode: Press and hold the "ACTIVATE CONTROLS" pad. While holding, press and hold the "HIGHER" and "ALARM OFF" pad simultaneously.

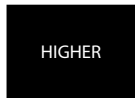

Continue holding until three beeps are heard and then "SHOW" is illuminated along with Refrigerator and 38°F or Freezer and 0°F.

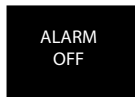

Whichever section was active prior to to showroom mode being entered will determine which one is displayed.

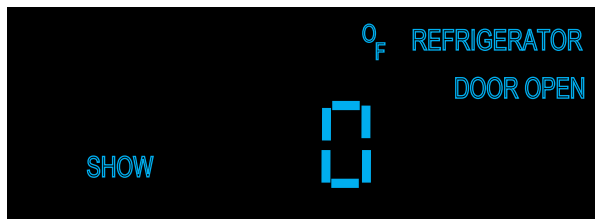

To exit Showroom mode: Press and hold the "ACTIVATE CONTROLS" pad. While holding, press and hold the "HIGHER" and "ALARM OFF" pad simultaneously. Continue holding until three beeps are heard. The display will revert to normal operation

## Sabbath Mode

To enter Sabbath mode, press and hold "ACTIVATE CONTROLS" pad then press and hold "DISPLAY OFF" pad, together for three seconds this will cause an audible three beeps, signifying that Sabbath mode has been entered.

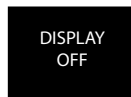

When Sabbath mode has been entered the display goes blank except for the "SAB", see illustration below, which will remain illuminated whether the door(s) are open or closed, it will not change state.

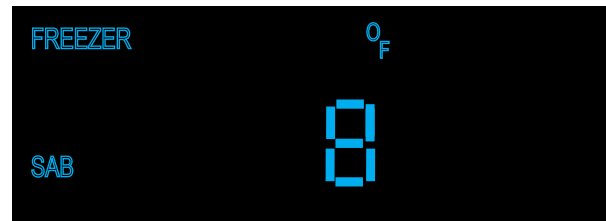

Sabbath mode is used to control the refrigerator without interior lights, LED display changes and enunciators. Alarms are suppressed, you will not get visual or audible alarms during Sabbath mode, although they are recorded in memory and will be displayed upon exiting Sabbath mode.

The freezer/refrigerator outputs (compressor, fans, etc.) should not have an immediate reaction from a user action. If the control calls for an action because the door was opened or closed, the control shall delay its reaction randomly (15-25 seconds).

To exit "SABBATH" mode, press and hold "ACTIVATE CONTROLS" and then "DISPLAY OFF" together for three seconds, an audible three beeps will be heard and "SAB" on display will extinguish. The display will return to normal and any alarms will be visually and audibly displayed.

## Fahrenheit to Celsius

Factory default for readout is Fahrenheit, to change to Celsius, press and hold "ACTIVATE CONTROLS" and then press and hold "DISPLAY OFF" for three seconds and °F will change to °C. To change back to Fahrenheit, repeat same steps.

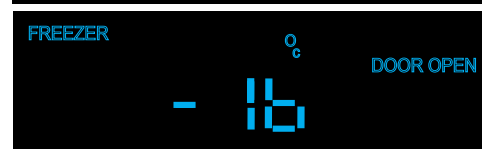
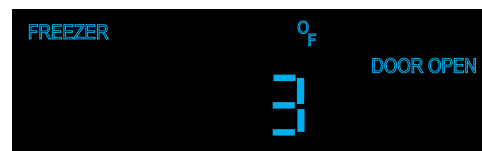
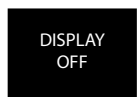

## Display Panel Operation

The unit being serviced has a control panel that allows operation of the unit as well as diagnostic abilities. See the information below for details.

Operation	Description	How to Access Function
Keyboard Entry Tone	Indicates a pad was pressed, command was read, and accepted	To turn off entry tone, press and hold "ACTIVATE CONTROLS" pad for 3 to 5 seconds
Command Accepted Tone	Three short tones sound indicating a command has been accepted	
"ACTIVATE CONTROLS" Pad	If the pad is activated, the display panel remains active at least 10 minutes after the door is closed	Press the "ACTIVATE CONTROLS" pad
"FRZ TEMP" Pad	"FREEZER" will light up and buffered freezer temperature will be displayed. Factory setting is 0° F	Press "HIGHER" or "LOWER" pad
"REF TEMP" Pad	"REFRIGERATOR" will light up and buffered refrigerator temperature will be displayed. Factory setting is 38° F	Press "HIGHER" or "LOWER" pad
"HIGHER" Pad	Raises temperature settings one degree at a time	Press "HIGHER" pad. To raise temperature at a faster rate, hold the pad down
"LOWER" Pad	Lowers temperature settings one degree at a time	Press "LOWER" pad. To lower temperature at a faster rate hold, the pad down
"FAST COOL" Pad	"FAST COOL" will light up enabling the fast cool function which changes the freezer set point to max frz and the ref set point to max ref for a factory default of 2 hours.	Press "FAST COOL" pad. A second press will disengage feature.
"MAX RFZ" Pad	Sets freezer temperature to coldest setting (-5° F). Factory setting is 6 hours	Press "MAX FRZ" Pad to engage. A second press will disengage feature
"MAX REF" Pad	Sets refrigerator temperature to coldest setting (33° F). Factory setting is 4 hours	Press "MAX REF" pad to engage. A second press will disengage feature
"ALARM OFF" Pad	Deactivates (partially or fully), audio/visual alarm signals	Press "ALARM OFF" to terminate audible alarm, visual alarm indicators will continue to blink until alarm condition is cleared or permanently disabled. To reactivate press and hold "ALARM OFF" pad for 3 seconds.
"DISPLAY OFF" Pad	Deactivates control panel except for "ACTIVATE CONTROLS" and "DISPLAY OFF" pads	Press "DISPLAY OFF" pad to deactivate display. Press "ACTIVATE CONTROLS" pad to reactivate

## Temperature Control Operation

For any temperature setting, outputs will be turned off/on based on cut-in/cut-out temperature determined by resistance levels of freezer or refrigerator thermistors.

Refrigerator and Freezer Thermistor (NTC)

As temperature decreases, resistance increases. As temperature increases, resistance decreases.

*Note: Open thermistor or thermistor circuit or a shorted thermistor will result in refrigerator continuing to cool with error code displayed. The affected section will call for cooling 100 percent of time except during defrost cycle*

Deg F	Deg C	K-Ohms
-24	-31	565
-22	-30	531
-20	-29	499
-18	-28	469
-16	-27	441
-15	-26	415
-13	-25	391
-11	-24	368
-9	-23	347
-8	-22	327
-6	-21	308
-4	-20	291
-2	-19	274
0	-18	259
1	-17	245
3	-16	231
5	-15	218
7	-14	206
9	-13	195

Deg F	Deg C	K-Ohms
10	-12	185
12	-11	175
14	-10	165
16	-9	157
18	-8	148
19	-7	141
21	-6	133
23	-5	126
25	-4	120
27	-3	114
28	-2	108
30	-1	103
32	0	97
34	1	93
36	2	88
37	3	84
39	4	80
41	5	76
43	6	72

Deg F	Deg C	K-Ohms
45	7	69
46	8	65
48	9	62
50	10	59
52	11	56
54	12	54
55	13	51
57	14	49
59	15	47
61	16	44
63	17	42
64	18	41
66	19	39
68	20	37
70	21	35
72	22	34
73	23	32
75	24	31
77	25	30

Freezer temperature setting and thermistor value will determine if compressor/condenser fan and evaporator fan switches are open or closed. Compressor/ condenser fan switch must be open for 6 minutes before switch can close again (compressor dwell time). Refrigerator temperature setting and thermistor value will determine if fresh food switch is open or closed. Cut-out and cut-in temperature values must be reached and maintained for 15 seconds before output state will change (digital delay). Refrigerator and freezer control calibration can be adjusted in Program Mode A.

## WARNING

To avoid risk of electrical shock, personal injury, or death, disconnect electrical power source to unit, unless test procedures require power to be connected. Ensure all ground wires are connected before certifying unit as repaired and/or operational.

### Parts Location—Control Panel

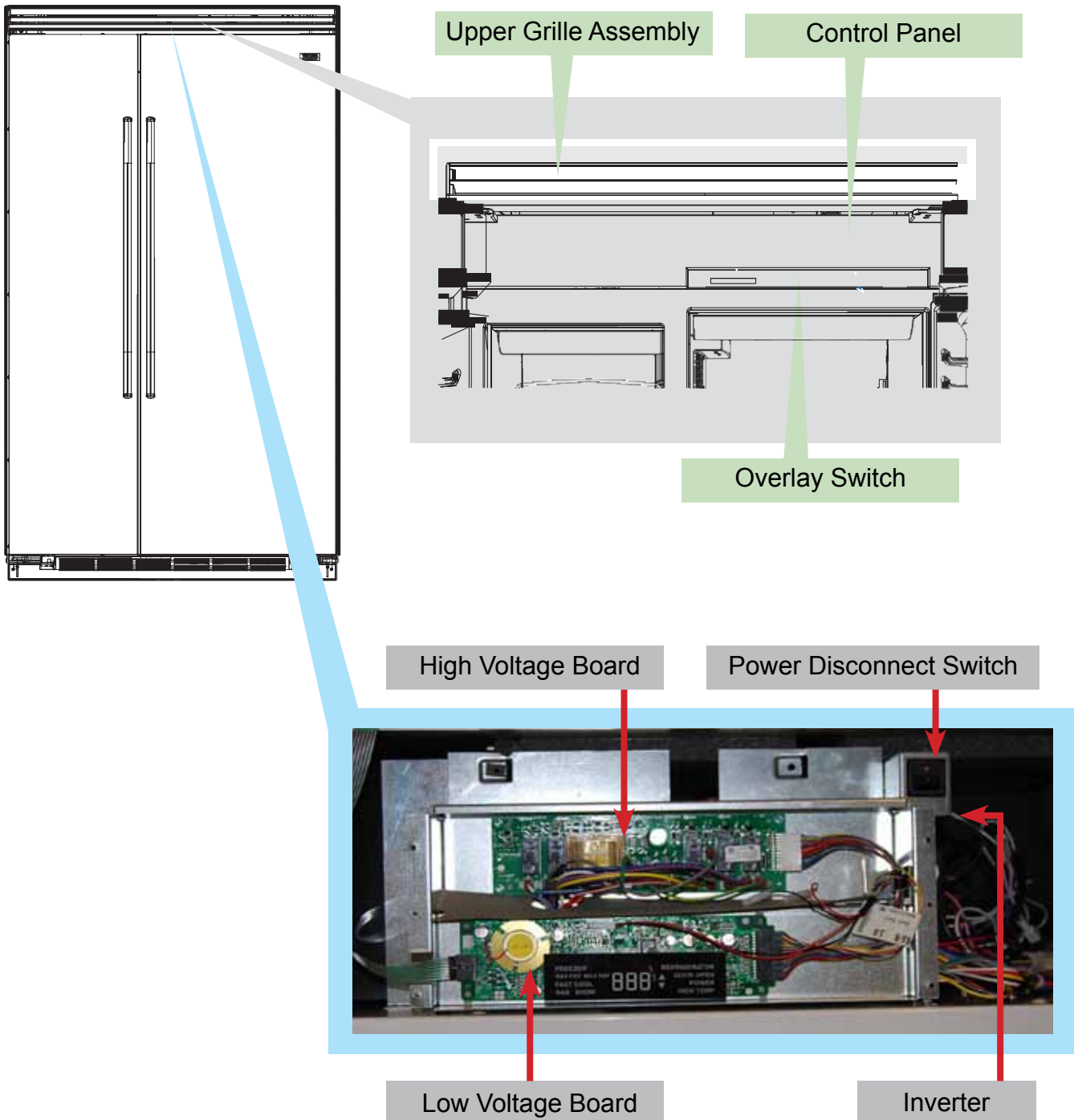

**⚠ WARNING**

To avoid risk of electrical shock, personal injury, or death, disconnect electrical power source to unit, unless test procedures require power to be connected. Ensure all ground wires are connected before certifying unit as repaired and/or operational.

**Upper Grille Assembly**

Removal of the upper grille assembly allows access to the control assembly.

1. To remove the upper grille assembly, slide out the middle air louver.



2. With the middle grille louver removed, remove the (2) 1/4" hex screws securing the grille assembly.



3. Remove the grille assembly



**Control Panel**

The control panel has an overlay switch attached to it that allows user input to the control boards.

1. To access the control panel, remove the upper air grill assembly (see Upper Grill Removal section), remove (2) screws securing the control panel.

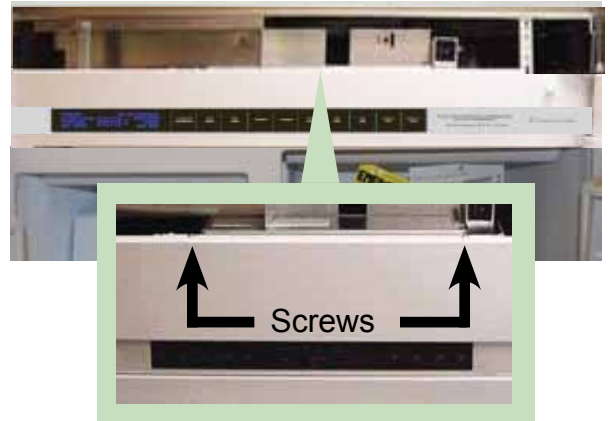

2. Pull control panel from securing tabs.

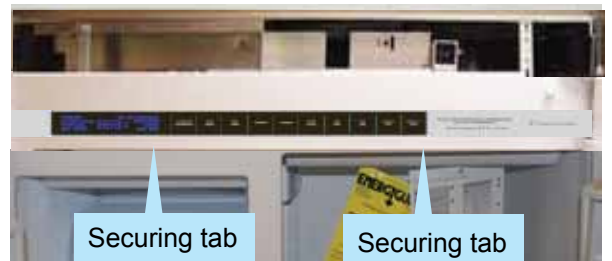

3. Lower the control panel. Take caution with the ribbon cable to prevent damage.



## WARNING

To avoid risk of electrical shock, personal injury, or death, disconnect electrical power source to unit, unless test procedures require power to be connected. Ensure all ground wires are connected before certifying unit as repaired and/or operational.

### Control Panel (continued)

4. Remove the four screws securing the control board cover. Remove control board cover.



5. Disconnect the door switches from the back of the control panel.

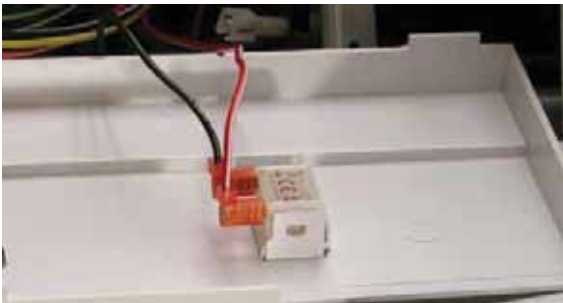

6. Disconnect the ribbon from the control board. Take caution with the ribbon cable to prevent damage.

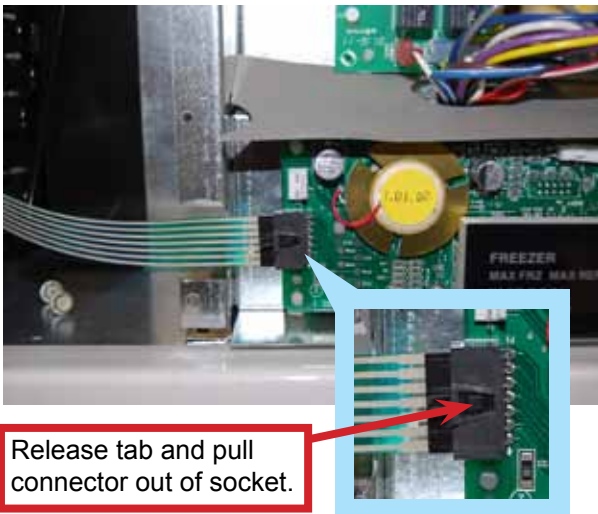

7. Remove the two strain relief screws.



8. The control panel can now be removed and the high voltage and low voltage boards are accessible

9. Reverse procedure to reinstall

### Overlay Switch

The unit uses an overlay switch to communicate user input to the control boards. The overlay connects to the control board via a ribbon cable.

1. To replace the overlay switch, remove the upper air grill assembly, remove the control panel (see Air Grill and Control Panel Removal sections, Page 13).
2. Disconnect overlay switch from control.

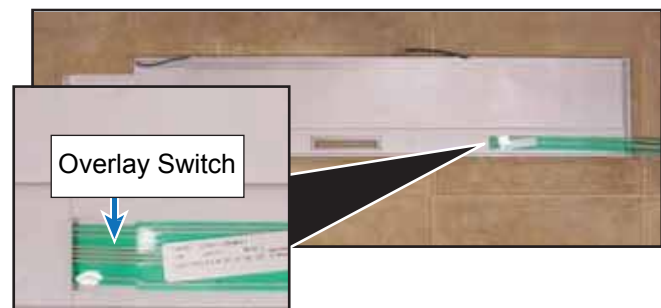

## ⚠ WARNING

To avoid risk of electrical shock, personal injury, or death, disconnect electrical power source to unit, unless test procedures require power to be connected. Ensure all ground wires are connected before certifying unit as repaired and/or operational.

### Overlay Switch (continued)

3. Peel overlay off control panel and remove (remove adhesive to ensure replacement overlay adheres properly)
4. Reverse procedure to reinstall.

### High Voltage Board

A control board is used to operate functions of the unit. Once an input is received from the low voltage board, the high voltage board sends an output to activate the components.

1. To access the high voltage board, remove the upper air grill assembly, and control panel (see Air Grill and Control Panel Removal sections, Page 13).
2. Compress plastic standoffs securing the high voltage board and pull towards you.

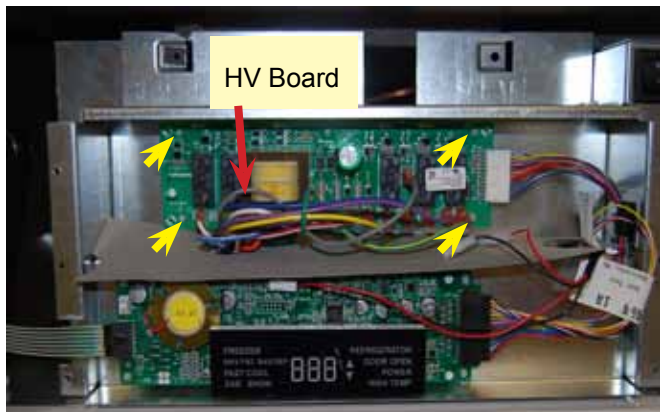

High voltage board is now accessible. To check high voltage board, refer to chart on page 47..

3. Reverse procedure to reinstall.

### Low Voltage Board

The unit uses a control board in conjunction with an overlay switch to operate functions of the refrigerator/freezer. Interaction with the low voltage board is via the ribbon cable attached to the overlay switch.

1. To access the low voltage board, remove the upper air grill assembly, control panel (see Air Grill and Control Panel Removal sections, Page 13).
2. Compress plastic standoffs securing low voltage board, disconnect wiring and remove.



LV Board

To check low voltage board, refer to chart on Page 48.

3. Reverse procedure to reinstall

## WARNING

To avoid risk of electrical shock, personal injury, or death, disconnect electrical power source to unit, unless test procedures require power to be connected. Ensure all ground wires are connected before certifying unit as repaired and/or operational.

### Power Disconnect Switch

The unit has a rocker switch, located in the upper right corner of the unit, that allows power to the unit to be turned "OFF" without removal of the unit.

## DANGER

ON/OFF switch has 120 vac connected to one side of switch at all times, remove power with circuit breaker box when removing switch.

1. To access the power disconnect switch, remove the upper air grill assembly (see Air Grill Removal section, Page 13). The power disconnect is now accessible on the right side.



Verify contacts 4-5 open when the switch is in the "0" position and contacts 4-5 close when in the "I" position. 120 VAC should be measured when in the "0" position and 0 VAC should be measured when in the "I" position.

2. Switch bracket is mounted on electronics box with two 1/4" hex head screws.
3. Reverse procedure to reinstall.

### Inverter

The Compressor is operated by a Inverter that varies the voltage to the compressor. This is determined by the frequency input from the low voltage board

1. To access the inverter, remove upper air grill assembly, remove control panel assembly (see Air Grill and Control Panel Removal sections, Page 13).
2. Remove the control box in order to gain easy access to the door hinge area for service. There are 4 1/4" hex screws (2 on each side) holding the control box to the refrigerator housing. Remove these screws.

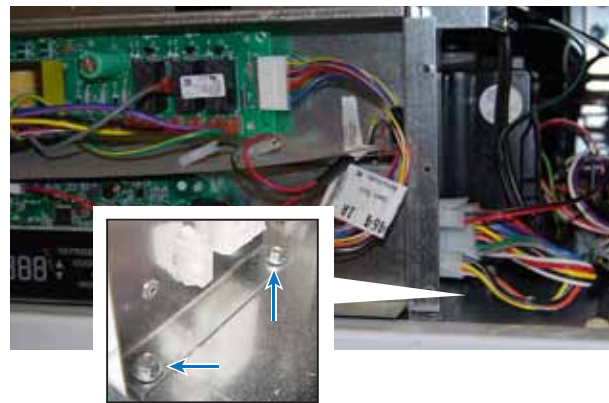

3. Unplug the 15-pin Molex power plug (A), as well as the 2-wire converter frequency cable (B) and the 3-wire thermistor plug (C).

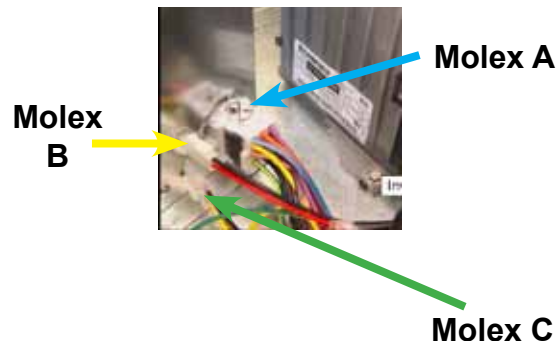



## ⚠ WARNING

To avoid risk of electrical shock, personal injury, or death, disconnect electrical power source to unit, unless test procedures require power to be connected. Ensure all ground wires are connected before certifying unit as repaired and/or operational.

### Inverter (continued)

- The inverter is now accessible on the right side.

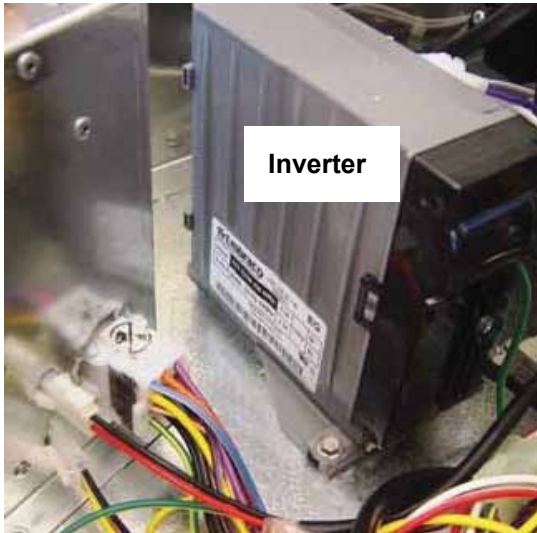

120 VAC is supplied to the inverter from E4 on the High Voltage Board. The LV board sends 5 VDC to the inverter to operate the compressor.

- Reverse procedure to reinstall.

### Condenser Fan

The condenser fan is located in the upper machine compartment of the unit. 120 VDC is supplied to the fan when the Compressor/Condenser Fan relay closes to E4 on the High Voltage Board.

- To access the condenser fan assembly, remove upper air grill assembly, remove control panel assembly (see Air Grill and Control Panel Removal sections, Page 13).

- Remove the control box in order to gain easy access to the door hinge area for service. There are 4 1/4" hex screws (2 on each side) holding the control box to the refrigerator housing. Remove these screws.

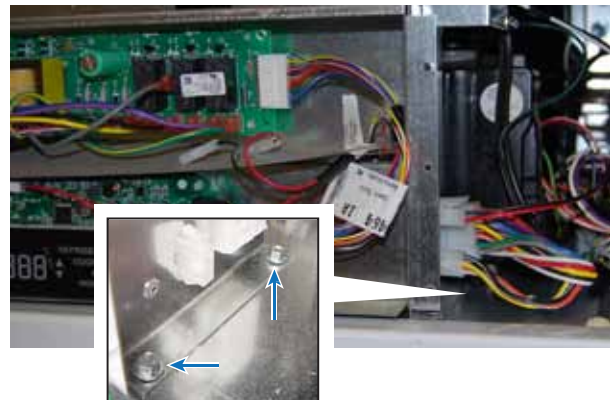

- Unplug the 15-pin Molex power plug, as well as the 2-wire converter frequency cable and the 3-wire thermistor plug. Remove electronics box and set aside to gain access to condenser fan assembly.
- Remove the three 1/4" hex screws holding fan assembly in place, remove fan assembly

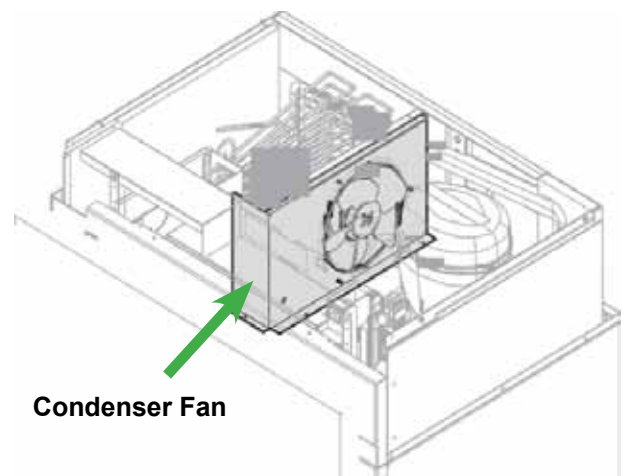

## **WARNING**

To avoid risk of electrical shock, personal injury, or death, disconnect electrical power source to unit, unless test procedures require power to be connected. Ensure all ground wires are connected before certifying unit as repaired and/or operational.

### Parts Location—Refrigerator Compartment

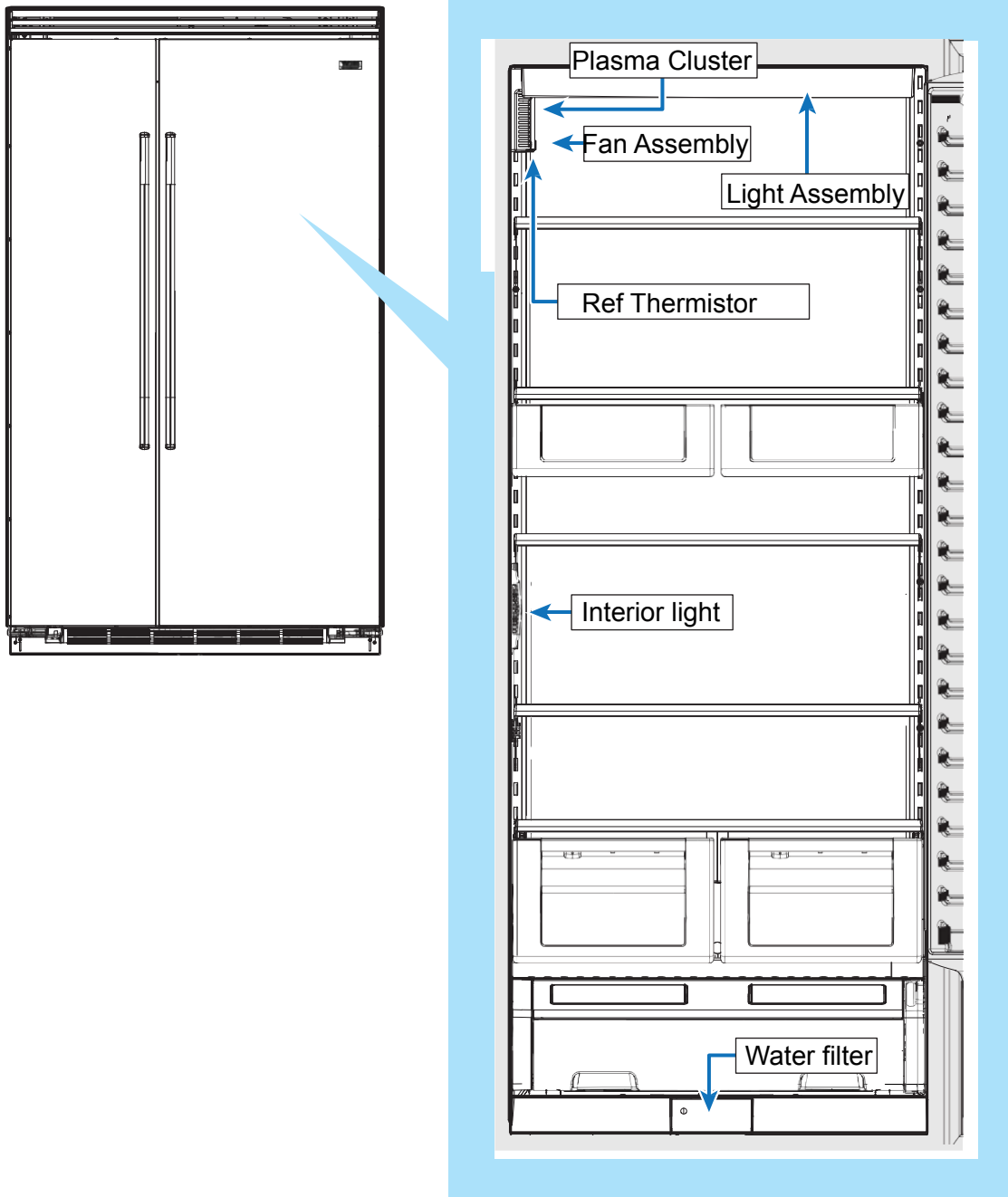

**⚠ WARNING**

To avoid risk of electrical shock, personal injury, or death, disconnect electrical power source to unit, unless test procedures require power to be connected. Ensure all ground wires are connected before certifying unit as repaired and/or operational.

**Light Assembly**

The unit uses 40 watt bulbs to light the unit. The bulbs are located at the top of unit.

To access bulbs, remove light cover and bulb is accessible.

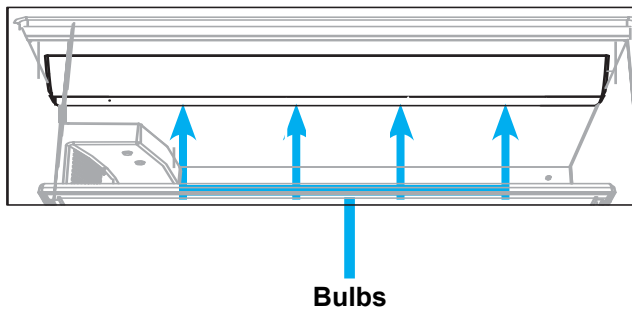

To check bulb, verify filament is not broken, resistance in the bulb, and voltage is supplied to the socket.

**Fresh Food Fan Assembly**

The Side-by-Side units uses a fresh food fan to circulate air through the refrigerator compartment. The fresh food fan is wired in parallel with the cross over fan. When the board calls for the fan to operate, 24 VDC is sent to the fan via the E1 (Purple) at the H.V. Board.

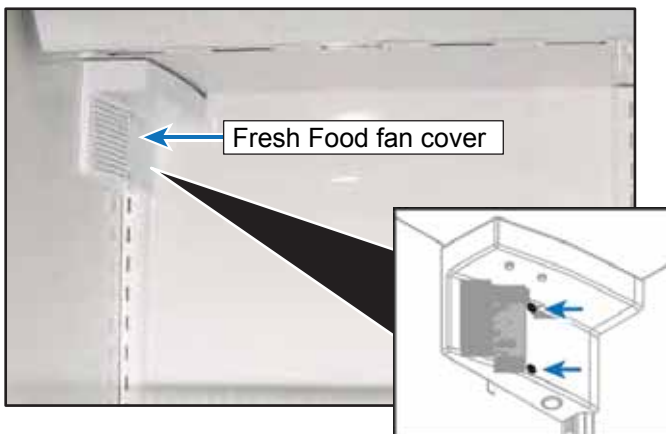

1. To access the fan, open the refrigerator door and remove the upper shelf. Remove (2) screws securing fan cover.
2. Lower fan cover to expose fresh food fan and disconnect wiring.

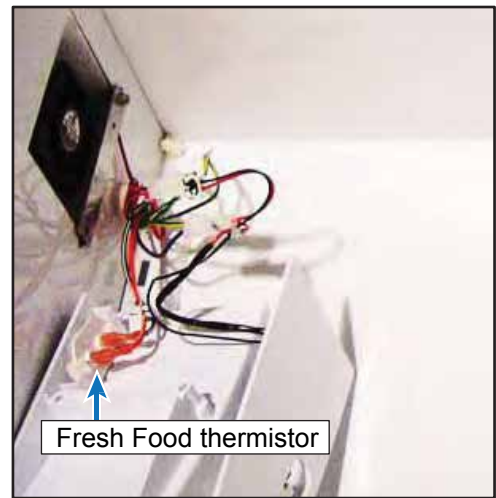

3. Open freezer door and remove (2) screws securing air cover.

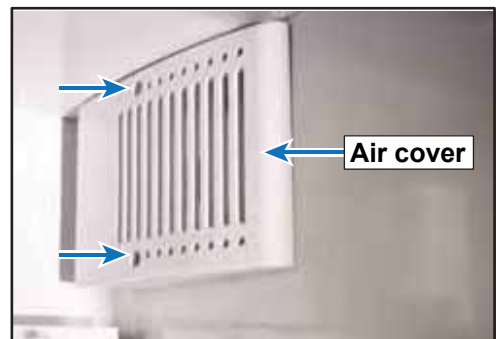

4. Remove (2) screws securing fresh food fan and repair/replace fan.

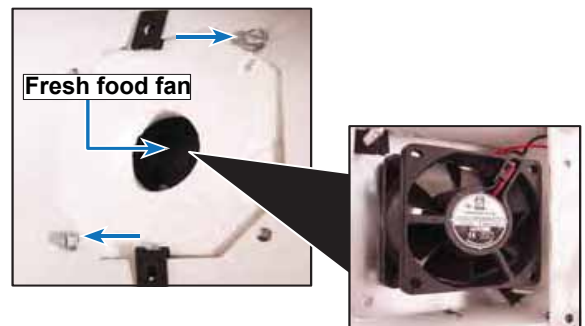

## WARNING

To avoid risk of electrical shock, personal injury, or death, disconnect electrical power source to unit, unless test procedures require power to be connected. Ensure all ground wires are connected before certifying unit as repaired and/or operational.

### Interior Lights

The unit uses two lights, one in the fresh food section and one in the freezer section, to provide lighting for the cabinet.

1. To access the light bulb, remove shelves.
2. Remove light cover. The fresh food light cover is removed by pressing up on the bottom of cover while gently pulling out on the top of the cover to release the cover tab from the mounting plate. The freezer light cover is removed by pushing down on the top of the light cover while gently pulling out on the bottom of the cover to release the cover tab from the mounting plate.



3. Remove the three securing screws to access the socket.



4. Remove the light assembly and replace/repair the socket.
5. Reverse procedure to reinstall.

### Plasma Cluster™

The Plasma Cluster™ ion air purifier uses ions to eliminate airborne bacteria, mold spores, and food odors without having to be replaced.

1. To access the plasma cluster, remove air cover (see fresh food fan procedure, Page 19).
2. With cover removed, remove the double sided tape securing the plasma cluster to the air cover, disconnect wiring, and repair/replace plasma cluster.



3. Reverse procedure to reinstall.

**⚠ WARNING**

To avoid risk of electrical shock, personal injury, or death, disconnect electrical power source to unit, unless test procedures require power to be connected. Ensure all ground wires are connected before certifying unit as repaired and/or operational.

**Parts Location–Freezer Compartment and Lower Unit–Non Dispenser**

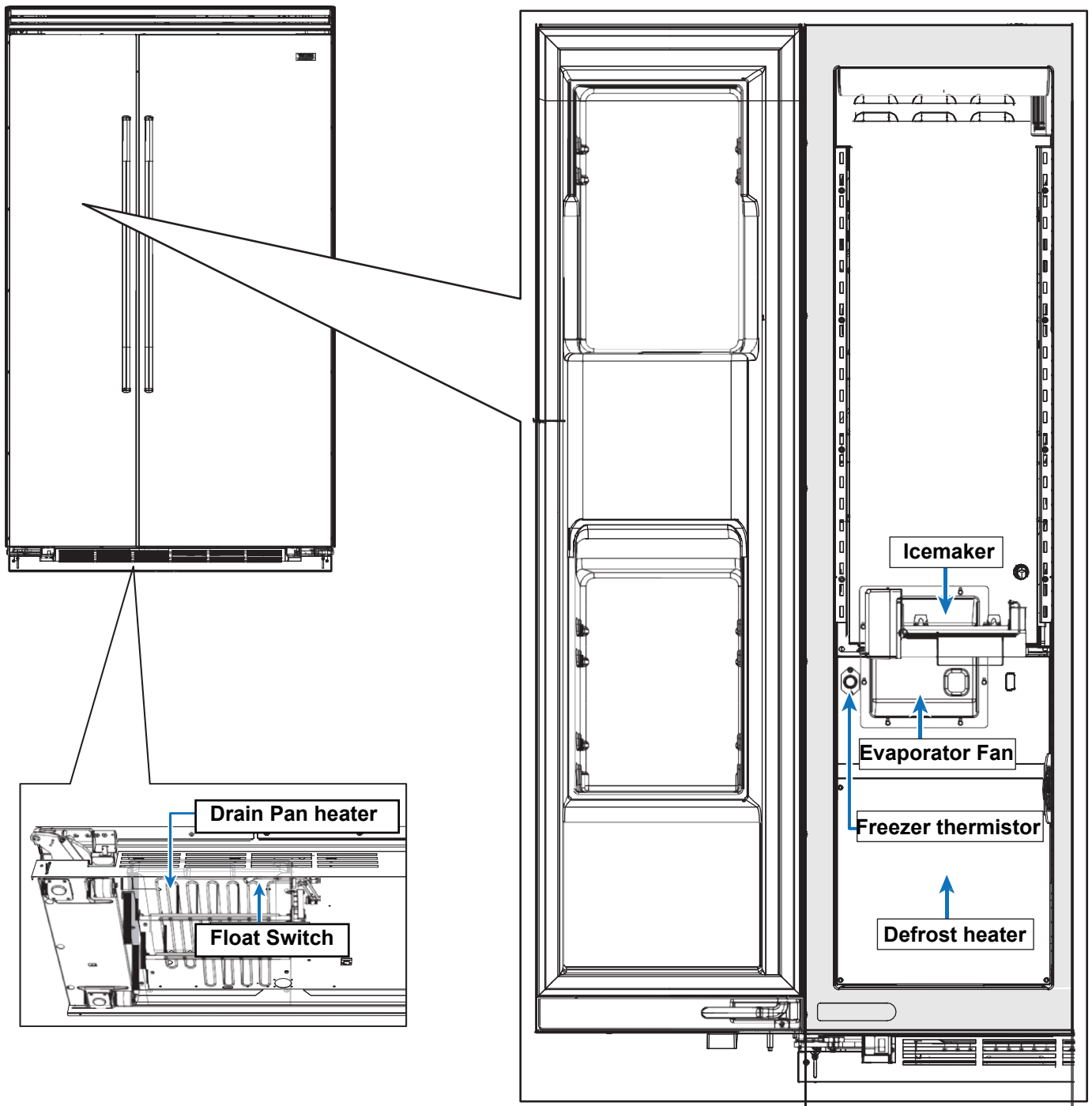

## **WARNING**

To avoid risk of electrical shock, personal injury, or death, disconnect electrical power source to unit, unless test procedures require power to be connected. Ensure all ground wires are connected before certifying unit as repaired and/or operational.

### Ice Maker (shown here with cover off)



The unit uses an ice maker that consists of a mold heater, thermostat, motor, and wire harness. The ice maker always starts from and stops at the “park” position. In the park position (the ejector blades are pointing horizontally towards the back of the ice maker). Just before reaching the park, position the mold is filled with water. At the park position all electrical components are de-energized, even though the shut-off arm is down, and the ice maker is ready for the next freeze cycle. The ice maker takes from 30 minutes to one hour to freeze the water. The primary time factors are the temperature in the freezer and the amount of airflow around the ice maker. Colder freezer settings and free air space around the ice maker to let air circulate will help make ice faster. After the ice forms, the ice maker continues to wait until it reaches 15°F before it starts the harvest cycle. This ensures that the ice is solid in all the cavities. At 15°F the thermostat closes, the mold heater turns on, and the ejector blades rotate up and forward until they stall out against the ice. The motor is designed to stall out and is geared to generate a lot of pressure. This minimizes the amount of melting needed to extract the ice. As soon as the ice is loose enough to move, the ejector pushes the ice out of

the mold during the second half of the first revolution. During the second revolution, the ejector pushes the ice into the bucket.

Just before the ejector completes the second revolution, the ice maker turns the water valve on for approximately 7 seconds and refills the mold with approximately 4 ounces of water and the freezing cycle is ready to begin again.

To access the ice maker, open the freezer door, remove bottom cover and the ice maker is accessible.

To access module, motor, and support assembly loosen screws in module access ports, disconnect shutoff arm, disconnect wiring harness and remove mold from support assembly.

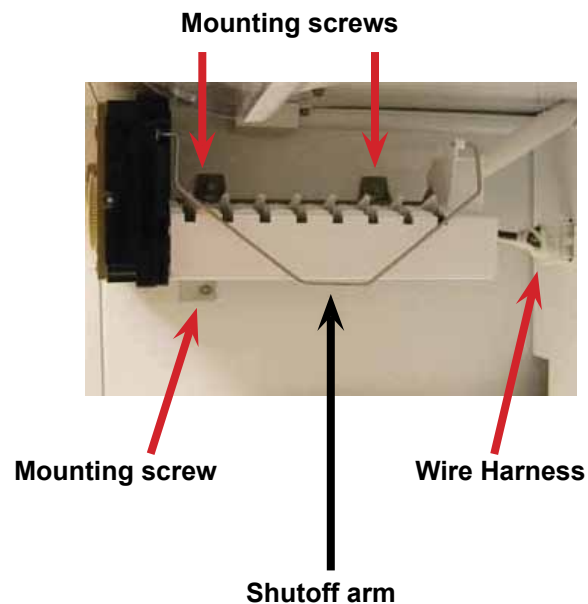

## ⚠ WARNING

To avoid risk of electrical shock, personal injury, or death, disconnect electrical power source to unit, unless test procedures require power to be connected. Ensure all ground wires are connected before certifying unit as repaired and/or operational.

To access module and heater assembly, remove three screws on front of module and remove support assembly.

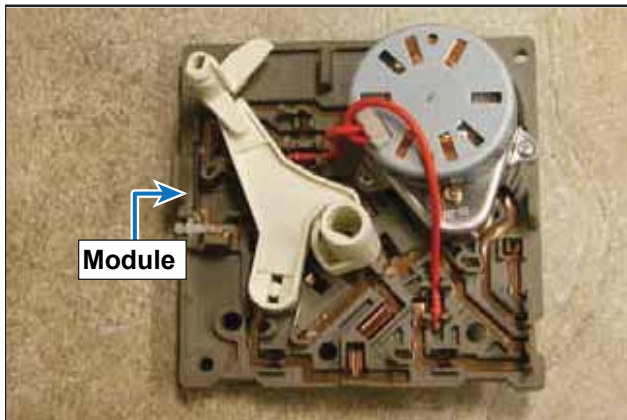

To make ice, an ice maker needs power, water, and sub-freezing temperatures.

Note: The freezer door switch turns off power to the ice maker when the freezer door is open. It will be necessary to manually close the freezer door switch for some troubleshooting steps. Ensure that the shut-off arm is down and instruct customer on its use if necessary.

To ensure power to the ice maker without a meter, remove the module cover and take note of the test points.

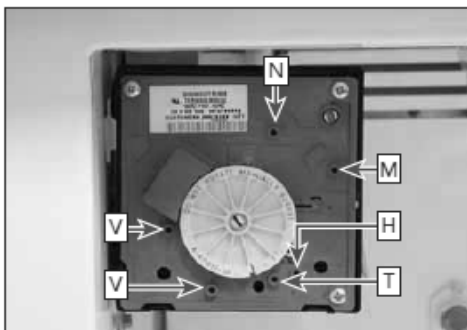

N - Neutral side of line voltage

M - Motor connection

H - Heater connection

T - Thermostat connection

L - L1 (hot) side of line voltage

V - Water valve connection

Place a 14 gauge jumper wire across test points T and H. With hands clear of the ice maker, manually close the freezer door switch. This will put the ice maker in a manual cycle. If the ejector does not rotate, this indicates no power to the ice maker. Trace power from the wall socket to the door switch and to the connector. Repair circuit and connections or replace door switch as needed. If the ejector begins to rotate (very slowly) there is power. With power present, verify 0 VAC between test points T and H (this verifies the thermostat has closed). Verify heater resistance is approximately 264  $\Omega$ . With motor running, verify heater is heating. If no heat is detected, replace mold assembly. Next ensure water is supplied to the ice maker. When the ejector blade gets to the 11:00 position, the water valve is energized for 7.5 seconds.

Verify the water valve has 120 VAC between test points V and N and approximately 4.75 ounces of water is dispensed. If voltage is present and water is not dispensed verify water supply and fill rate. Poor water quality can cause ice maker to fail or produce unacceptable cubes. Install a water filter

## **WARNING**

To avoid risk of electrical shock, personal injury, or death, disconnect electrical power source to unit, unless test procedures require power to be connected. Ensure all ground wires are connected before certifying unit as repaired and/or operational.

to eliminate bad taste, odor, and visible contaminates. Mineral content or sand can restrict screen in water fill valve or particles of sand can keep valve from seating properly.

If water valve does not operate properly, the following could occur: no ice production, small or hollow ice cubes, flooding of ice container. Mineral content can cause lime build up in the mold, wicking of water over the mold and poor cube release. Mineral content can also restrict saddle valves. Verify water supply line is "ON", water pressure is not below 20 psi, saddle valve

is fully open clear restrictions by fully closing and opening valve to dislodge sediment (if necessary, remove valve and enlarge pierced hole to 3/16" diameter with a drill and reinstall saddle valve) ensure water line to unit is not pinched/kinked/ clogged, ice is not present in inlet tube blocking water flow, water pressure is not above 120 psi. Water fill can be increased by turning the adjustment screw counterclockwise and decreased by turning the screw clockwise. One half turn will adjust the fill by approximately two thirds of an ounce. If supply is OK replace water valve. If no voltage is present, verify harness. If OK, replace module.

<b>Module Ohmmeter Checks No power to icemaker and Ejector blades in end of cycle</b>			
<b>Test Points</b>	<b>Component</b>	<b>Module Position</b>	<b>Ohms</b>
<b>L-H</b>	<b>Mold &amp; Heater</b>	<b>Attached to support</b>	<b>264</b>
<b>L-M</b>	<b>Motor</b>	<b>Separate from heater</b>	<b>16,100</b>
<b>Module Voltage checks with motor or test light power to icemaker</b>			
<b>Test Points</b>	<b>Component</b>	<b>Line Voltage</b>	<b>0 Volts</b>
<b>L-N</b>	<b>Module</b>	<b>Power On</b>	<b>Power Off</b>
<b>T-H</b>	<b>Bimetal</b>	<b>Open</b>	<b>Closed</b>
<b>L-H</b>	<b>Heater</b>	<b>On</b>	<b>Off</b>
<b>L-M</b>	<b>Motor</b>	<b>On</b>	<b>Off</b>
<b>N-V</b>	<b>Water valve</b>	<b>On</b>	<b>Off</b>



## ⚠ WARNING

To avoid risk of electrical shock, personal injury, or death, disconnect electrical power source to unit, unless test procedures require power to be connected. Ensure all ground wires are connected before certifying unit as repaired and/or operational.

### Thermal Cut Out (TCO)

The TCO is a safety device and must NOT be bypassed. If the TCO is found to be electrically open, this indicates an overheat in the ice maker and the ice maker must be replaced.

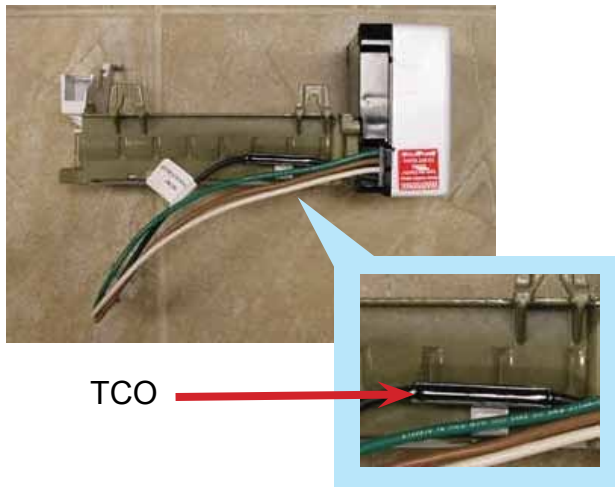

3. Remove right side light lens (see interior lights page 53).

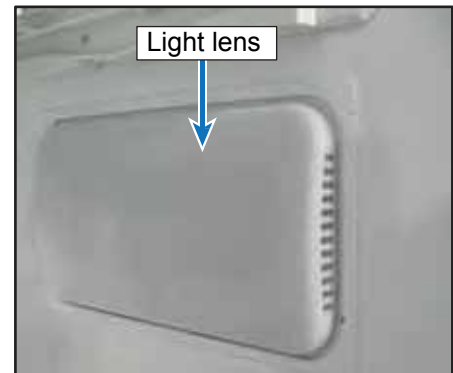

4. Remove screws and center evaporator cover.



### Freezer Evaporator Fan

1. Remove lower freezer baskets.
2. Remove screws securing left and right freezer glides and remove glides.



## **WARNING**

To avoid risk of electrical shock, personal injury, or death, disconnect electrical power source to unit, unless test procedures require power to be connected. Ensure all ground wires are connected before certifying unit as repaired and/or operational.

5. Disconnect wiring, and repair/replace freezer fan.

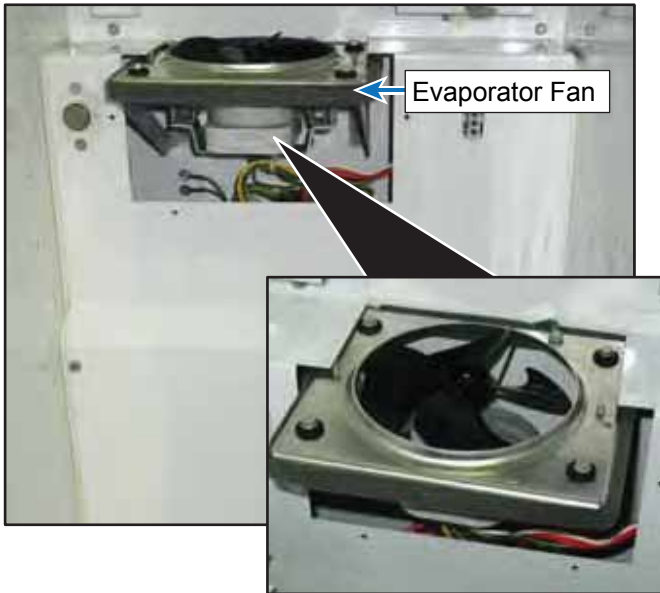

3. Pull thermistor into freezer cabinet, disconnect wiring, repair/replace thermistor.

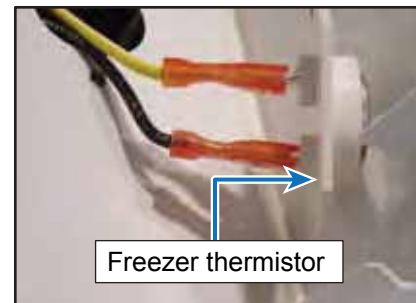

6. Reverse procedure to reinstall.

### **Freezer Thermistor**

The freezer uses the same thermistor as does the fresh food section however, the freezer thermistor controls the cycle of the compressor. As the temperature in the compartment changes, the resistance in this device changes. These changes are measured by the low voltage board, and controls the operation of the compressor, condenser, and freezer evaporator fan. Refer to the thermistor chart on page 11.

To access the freezer thermistor:

1. Remove drawers and shelves.
2. Remove screws securing the thermistor.

4. Reverse procedure to reinstall.

### **Defrost Heater**

The unit use a heater to help remove ice build up during the defrost cycle. When the defrost terminator closes, voltage is supplied to the heater via the control board. With the main power switch OFF, the defrost Heater can be tested by removing the orange wire off of terminal E6 on the HV board. Using an ohm meter, check the brown wire and Neutral and you should read approximately 30  $\Omega$ . During the defrost cycle Line voltage passes through the Defrost Terminator the into terminal E5 (orange wire). With the defrost heater relay activated, the voltage

## ⚠ WARNING

To avoid risk of electrical shock, personal injury, or death, disconnect electrical power source to unit, unless test procedures require power to be connected. Ensure all ground wires are connected before certifying unit as repaired and/or operational.

exits the HV board from Terminal E6 (orange) to the heating element. If voltage is present at E5 but not at E6, then the Defrost relay is open. If there is 0 volts At E5, then the terminator is open.

Another method to test can be achieved by testing at the 15-wire Molex plug on the right side of the Control Housing. Refer to page 82 pin locations.

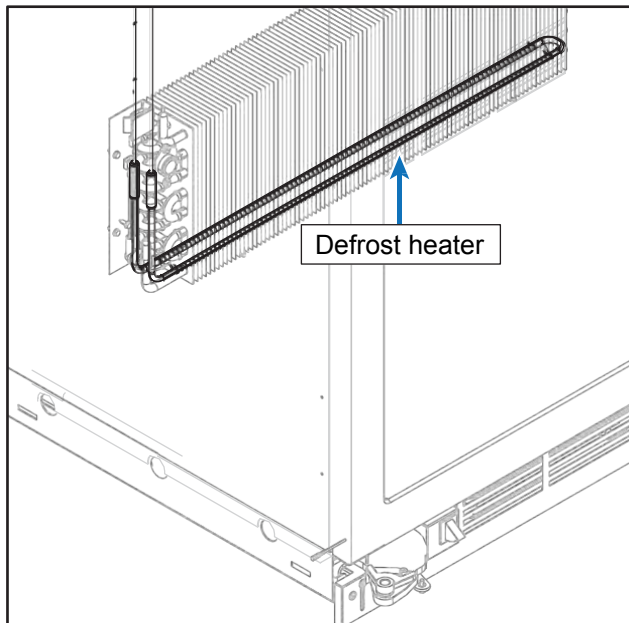

1. Remove screws securing rear panel and remove rear panel.

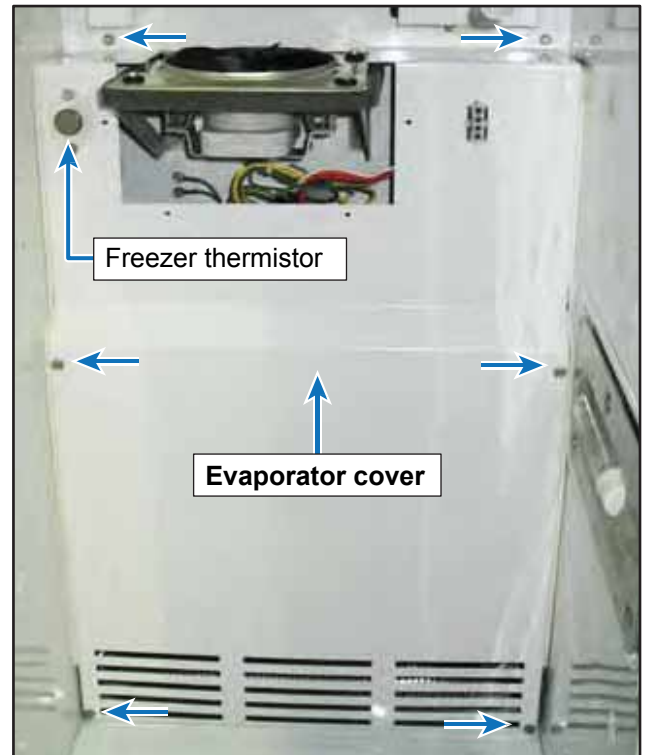

2. Remove clips securing defrost heater, disconnect wiring, and repair/replace defrost heater.

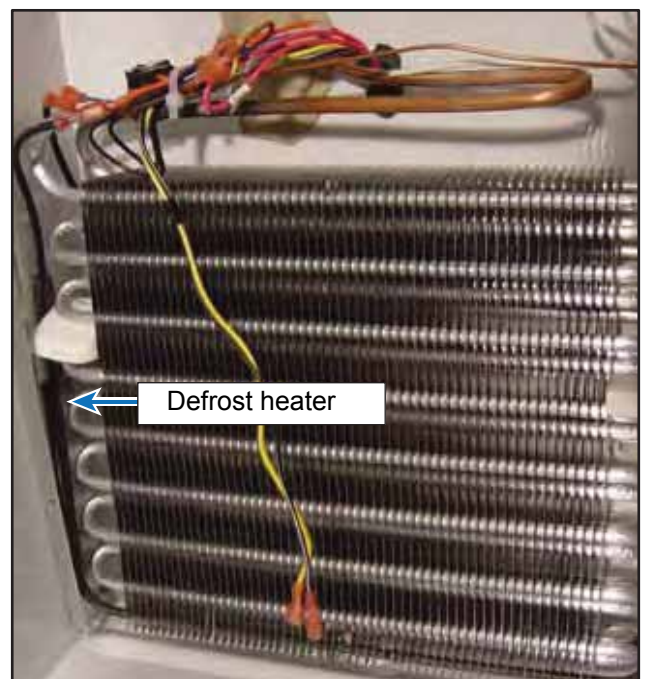

## WARNING

To avoid risk of electrical shock, personal injury, or death, disconnect electrical power source to unit, unless test procedures require power to be connected. Ensure all ground wires are connected before certifying unit as repaired and/or operational.

3. Reverse procedure to reinstall.

### Defrost Terminator

The defrost terminator is a bimetal switch that is normally open. Below 20+/-8.5 °F, the terminator is closed. In order to test, first switch the main power switch to “Off”. Locate the brown wire on E5 of the HV board. Unplug the wire and check for continuity between the brown wire and the black wire at E10. If “0” is read then the bimetal is closed. If infinity ( $\infty$ ) is read, the bimetal is open.

Note: Freezer temp must be below 20+/-8.5 °F in order to check for a defective bimetal.

Another method to test can be achieved by testing at the 15-wire Molex plug on the right side of the Control Housing. Refer to page 82 pin locations.

To access the defrost terminator:

1. Follow steps 1-4 under Defrost Heater disassembly.
2. Unclip the terminator, disconnect wiring, repair/ replace terminator.

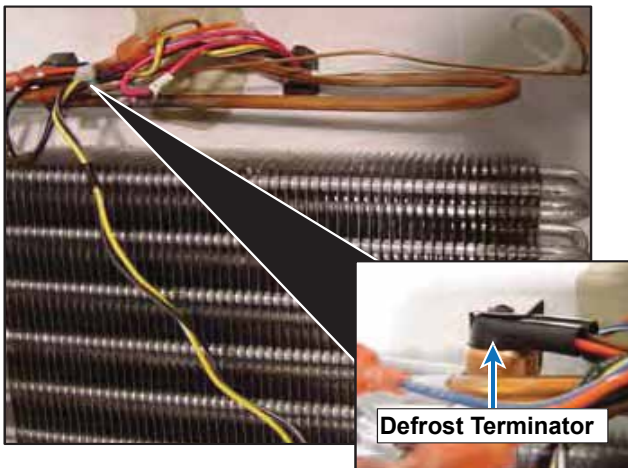

### Float Switch

The unit uses a float switch in conjunction with the drain pan heater to vaporize condensate created from the refrigerator cooling process. The switch is normally open and closes as the water level in the pan rises thus energizing the drain pan heater. When the water is vaporized the switch opens removing power from the drain pan heater.

To access the float switch, remove the lower access panel and the float switch is now accessible. Verify the switch reads infinite resistance when in the down position and 0  $\Omega$  in the up position. If the switch does not open or close properly, replace the float switch.

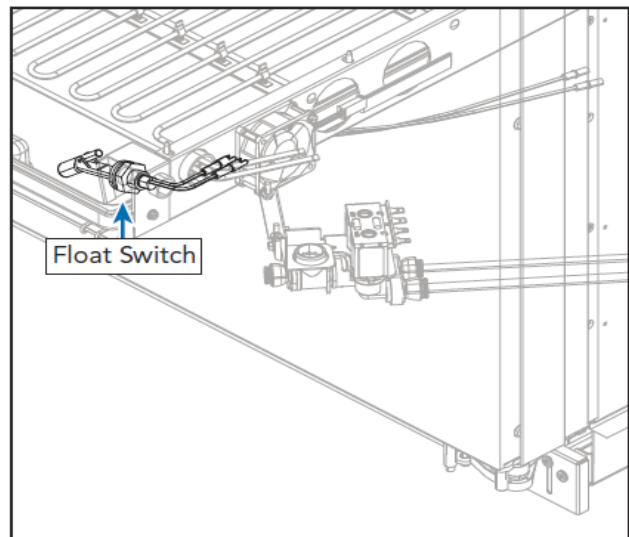

## ⚠ WARNING

To avoid risk of electrical shock, personal injury, or death, disconnect electrical power source to unit, unless test procedures require power to be connected. Ensure all ground wires are connected before certifying unit as repaired and/or operational.

### Water Valve

The Non-Dispenser Side-by-Side models utilize a single coil water valve to fill the ice maker when required.

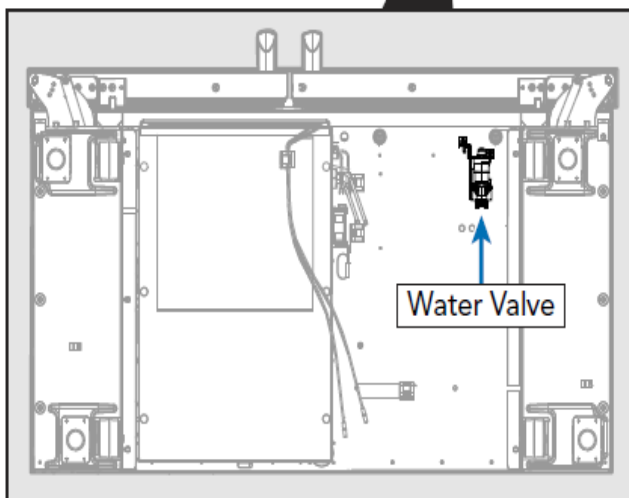
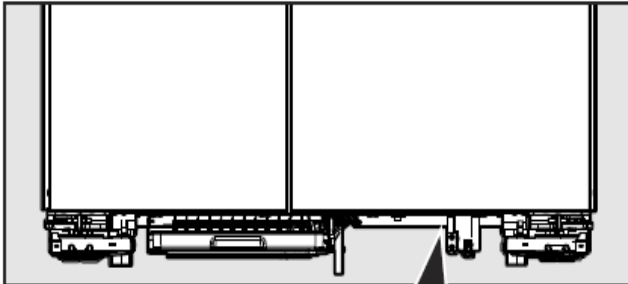

Bottom View

### Drain Pan Heater

The unit uses a drain pan heater to evaporate condensate created by the refrigerator cooling process. The pan heater is energized once the float switch closes supplying 120 VAC.

To access the drain pan heater, remove the lower access panel and the drain pan heater is accessible. Verify the resistance is approximately 790  $\Omega$ . Verify 120 VAC to the heater and the float switch is closed. If the switch is closed and no voltage is supplied, verify wiring, power disconnect switch has not been turned "ON", and supply voltage. If voltage is supplied, the float switch is closed, and the heater does not energize, replace the heater.



## Program Modes

### Program Mode A

Program mode A is entered by first pressing and releasing "ACTIVATE CONTROLS", then press and release "FAST COOL" once and within five seconds press and release the following pads in sequence, "HIGHER, LOWER, HIGHER, LOWER" You will hear an audible three beeps and the numeric display will change to "PrA", see illustration below.

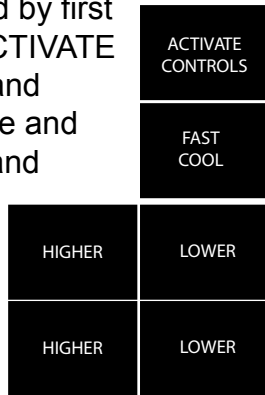

### Display Ref Temperature

Press "REF TEMP" pad once to display the value of the thermistor temperature with the offset, no filtering is applied to the display. This readout will reflect instantaneous temperature changes on the refrigerator thermistor as shown below.

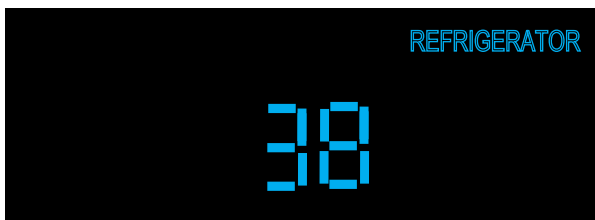

### Display Frz Temperature

Press "FRZ TEMP" pad once to display the value of the thermistor temperature with the offset, no filtering is applied to the display. This readout will reflect instantaneous temperature changes on the freezer thermistor as shown in illustration, next column.

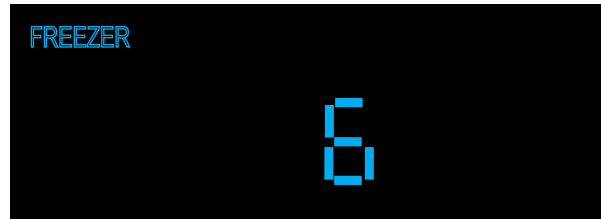

### Defrost mode selection

Unit is shipped in Adaptive defrost mode, this can be changed to Conventional defrost mode using the following procedure while in Mode A.

Press the "FAST COOL" pad once to display the current defrost mode. This will result in a display of "Add" for adaptive or "Cnd" for conventional as shown in the illustrations below.

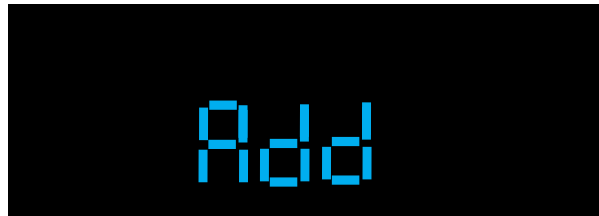
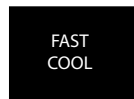

At this point pressing and releasing the "FAST COOL" pad will toggle between adaptive and conventional defrost modes of operation.

### Conventional defrost time adjustment (CRTD)

The conventional defrost is adjusted based upon compressor run time between defrost cycles (CRTD). This time can be adjusted from between 4 hours (minimum) to 24 hours (maximum) in one hour increments.

Conventional defrost must first be selected as shown in previous step.

Press and hold the "ALARM OFF" pad for three seconds until you hear 3 audible beeps and the display changes to "cd".

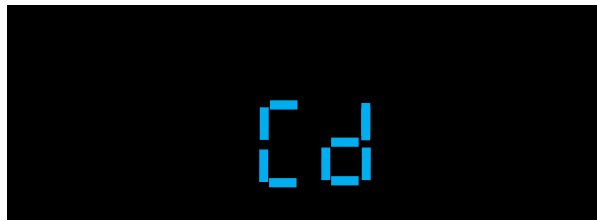
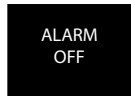

Pressing the "HIGHER or LOWER" pads will result in number of hours being displayed and can be adjusted in one hour increments from 4 hours to 24 hours CRTD interval.

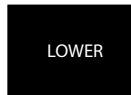

To exit this time period adjustment press and release "ACTIVATE CONTROLS" one time which will result in "PrA" being displayed. You are now back in Mode A.

### Compressor low speed frequency

Compressor low speed frequency is set to a predetermined value based upon model of refrigerator. This value can be set in Mode A as a separate adjustment or can be set automatically in Mode C when selecting model code, where several control values are set by eeprom. Table 1 on Page 42 lists eeprom values set by model code.

To enter low speed frequency adjustment in Mode A, press and release "DISPLAY OFF" once, this will result in the display "CLF".

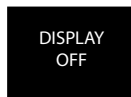

Pressing and releasing "HIGHER or LOWER" pads will bring the numeric display up, pressing and releasing changes in increments of 1 HZ, holding the key down changes in increments of 5 HZ.

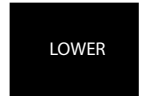

This value should be set at 75HZ for side by side model refrigerator,s see Table 1 on Page 42.

To exit the low speed adjustment press and release "ACTIVATE CONTROLS" one time which will result in "PrA" being displayed. You are now back in Mode A.

### Adjust Cut-In Hysteresis

Cut-In hysteresis for the refrigerator and freezer is set to predetermined values, based upon model of refrigerator. This value can be set in Mode A as a separate adjustment or can be set automatically in Mode C when selecting model code, where several control values are set by eeprom. Table 1 on Page 42 lists eeprom values set by model code.

While still in Mode A press and hold "ALARM OFF" and then "HIGHER" pad for three seconds, the display will change to "CIH".

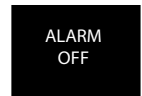

Press "REF TEMP" to select the refrigerator compartment, the display will illuminate "REFRIGERATOR" on display.



Next Press and release "HIGHER or LOWER" which will result in displaying degrees in Fahrenheit. For the refrigerator section this

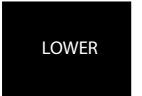
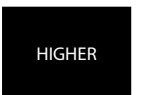

should be set to appropriate value in table below

Refrigerator Cut-In	
Model	Value
5421	6
5481	6

Using Higher and Lower pads set to correct value as in illustration below.

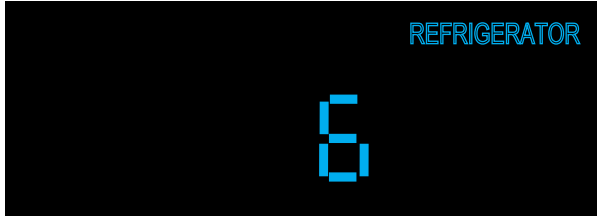

Press and release "FRZ TEMP", this will result in "FREEZER" illuminating on display.



The freezer section should be set to appropriate value in table below.

Freezer Cut-In	
Model	Value
5421	7
5481	7

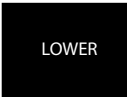

Using Higher and Lower pads set to correct value as in illustration below.



To exit the cut-in adjustment press and release "ACTIVATE CONTROLS" one time which will result in "PrA" being displayed. You are now back in Mode A.

## Adjust Cut-Out Hysteresis

Cut-Out hysteresis for the refrigerator and freezer is set to predetermined values, based upon model of refrigerator. This value can be set in Mode A as a separate adjustment or can be set automatically in Mode B when selecting model code, where several control values are set by eeprom. Table 1 on Page 42 lists eeprom values set by model code.

While still in Mode A press and hold "ALARM OFF" and then "LOWER" pad at the same time for three seconds, the display will change to "COH".



Press "REF TEMP" to select the refrigerator compartment, the display will illuminate "REFRIGERATOR" on display.

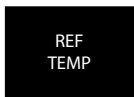

Next Press and release "HIGHER or LOWER" which will result in displaying degrees in Fahrenheit. For the refrigerator section this should be set to appropriate value in table below.



Refrigerator Cut-Out	
Model	Value
5421	-6
5481	-6

Using Higher and Lower pads set to correct value as in illustration below.

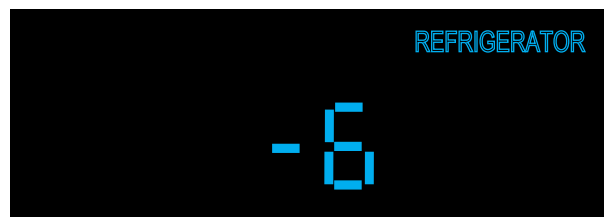



Press and release "FRZ TEMP", this will result in "FREEZER" illuminating on display.



The freezer section should be set to appropriate value in table below.



Freezer Cut-Out	
Model	Value
5421	-7
5481	-7



Using Higher and Lower pads set to correct value as in illustration below.

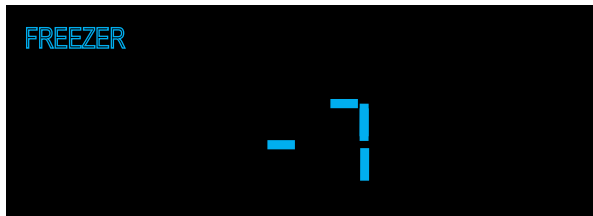

To exit the cut-out adjustment press and release "ACTIVATE CONTROLS" one time which will result in "PrA" being displayed. You are now back in Mode A.

### Display Software Version

While in Mode A, press and hold "DISPLAY OFF" for three seconds to show the software version on the temperature display. Pressing "HIGHER or LOWER" will cycle between a letter prefix and a two digit version as follows:

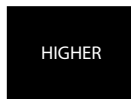
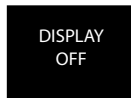

- "A" + the major version
- "B" + the minor version
- "C" the build number



### Exiting Mode A

*To exit Mode A and retain any changes made in system up to this point you must press and hold "ACTIVATE CONTROLS" for three seconds until you hear three audible beeps. This signifies that the changes were written to the eeprom and that the system has left Mode A and returned to normal operation. Failure to do this will cause system to time out after 10 minutes and any changes will be lost.*



## Program Mode B

If you are not already in Mode A, go back to Mode A instructions on Page 30.

Once you are in Mode A (PrA in display), press and release "ACTIVATE CONTROLS" one time and display will change to "Prb", signifying that control is now in Program Mode B, see illustration below.

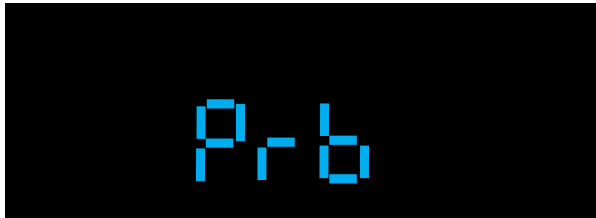

## Adjust Freezer Temperature Offset

Freezer temperature offset is a predetermined value, based upon model of refrigerator. This value can be set in Mode B as a separate adjustment or can be set automatically in Mode B when selecting model code, where several control values are set by eeprom. Table 1 on Page 42 lists eeprom values set by model code.

Press and release "FRZ TEMP" pad once, the "FREEZER" indicator will illuminate and the current freezer offset will be displayed along with °F.



This value should be set to appropriate value in table below.

Freezer Offset	
Model	Value
5421	-2
5481	-5

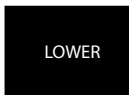
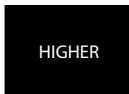

Using "HIGHER and LOWER" pads adjust value as in illustration below.

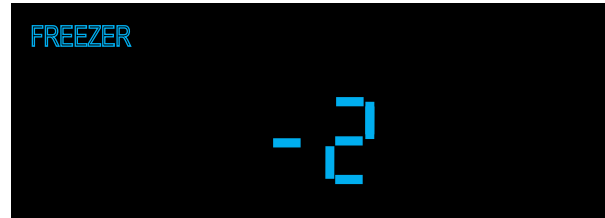

## Adjust Refrigerator Temperature Offset

Refrigerator temperature offset is a predetermined value, based upon model of refrigerator. This value can be set in Mode B as a separate adjustment or can be set automatically in Mode B when selecting model code, where several control values are set by eeprom. Table 1 on Page 42 lists eeprom values set by model code.

Press and release "REF TEMP" pad once, the "REFRIGERATOR" indicator will illuminate and the current refrigerator offset will be displayed along with °F.



This value should be set to appropriate value in table below.

Refrigerator Offset	
Model	Value
5421	-6
5481	-4

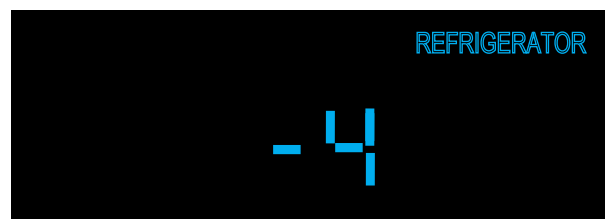
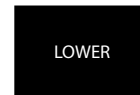

## Adjust MAX FRZ duration

While in Mode B, press and release "MAX FRZ" one time, this will result in "MAX FRZ" illuminating on the display along with the current numeric value in hours that MAX FRZ is set at. Factory default for this adjustment is 6 hours. Range is 1 to 20 hours in 1 hour increments.

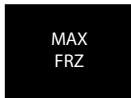

The duration is adjusted using the "HIGHER and LOWER" pads.

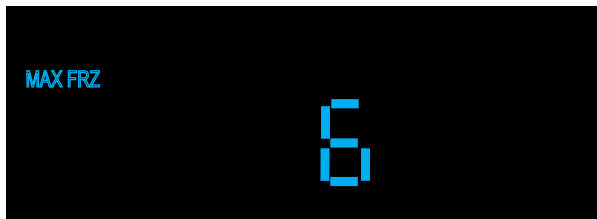
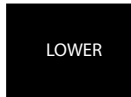

## Adjust FAST COOL duration

While in Mode B, press and release "FAST COOL" one time, this will result in "FAST COOL" illuminating on the display along with the current numeric value in hours that FAST COOL is set at. Factory default for this adjustment is 2 hours. Range is 1 to 20 hours in 1 hour increments.

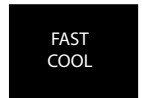

The duration is adjusted using the "HIGHER and LOWER" pads.

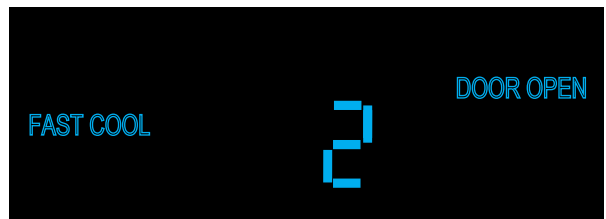
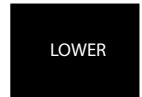
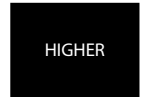

## Adjust MAX REF duration

While in Mode B, press and release "MAX REF" one time, this will result in "MAX REF" illuminating on the display along with the current numeric value in hours that MAX REF is set at. Factory default for this adjustment is 4 hours. Range is 1 to 20 hours in 1 hour increments.

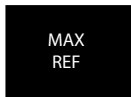

The duration is adjusted using the "HIGHER and LOWER" pads.

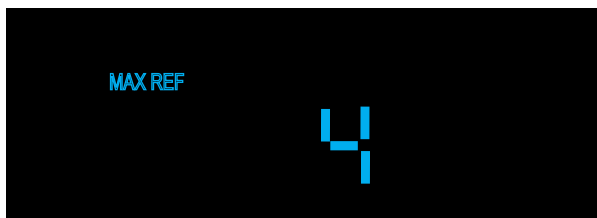
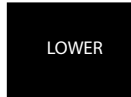

## Adjust Door Open Alarm delay

While in Mode B, press and release "ALARM OFF" one time, this will result in "DOOR OPEN" illuminating on the display along with the current numeric value in minutes that the delay is set at. Factory default for this adjustment is 3 minutes. Range is 1 to 20 minutes in 1 minute increments.

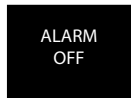

The duration is adjusted using the "HIGHER and LOWER" pads.

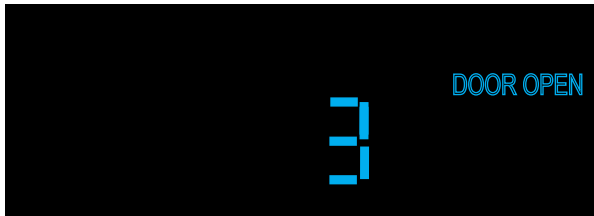
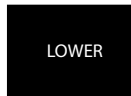
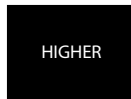

## Adjust Compressor Dwell Time

This adjustment is not a field adjustment and should not be performed by technicians. This is a factory only adjustment.

If you see "Cdt" in the display, immediately exit Mode B by holding "ACTIVATE CONTROLS" for three seconds until you get three audible beeps. Return to your previous actions.

## Adjust Compressor High Frequency

This adjustment is not a field adjustment and should not be performed by technicians. This is a factory only adjustment.

If you see "CHF" in the display, immediately exit Mode B by holding "ACTIVATE CONTROLS" for three seconds until you get three audible beeps. Return to your previous actions.

## Adjust DC Fan Cycling On Time

This adjustment is not a field adjustment and should not be performed by technicians. This is a factory only adjustment.

If you see "dCo" in the display, immediately exit Mode B by holding "ACTIVATE CONTROLS" for three seconds until you get three audible beeps. Return to your previous actions.

## Adjust DC Fan Cycling Off Time

This adjustment is not a field adjustment and should not be performed by technicians. This is a factory only adjustment.

If you see "dCF" in the display, immediately exit Mode B by holding "ACTIVATE CONTROLS" for three seconds until you get three audible beeps. Return to your previous actions.

## Exiting Mode B

**To exit Mode B and retain any changes made in system up to this point you must press and release "ACTIVATE CONTROLS" one time, the display changes to "PrA". This signifies that the changes were written to the eeprom and that the system has left Mode B and returned to Mode A.**



**The other way to ensure changes have been written into the eeprom is to press and hold "ACTIVATE CONTROLS" for three seconds and you will get three audible tones along with a normal temperature display. This indicates that you have left Mode B and returned to normal operation.**

**Failure to do this will cause system to time out after 10 minutes and any changes will be lost.**

## Program Mode C

If you are not already in Mode B, go back to Mode B instructions on Page 34.

Once you are in Mode B (Prb in display), press and hold "ALARM OFF" for three seconds and display will change to "PrC", signifying that control is now in Program Mode C, see illustration below.

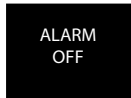

### Set Model type

While in Mode C, press and release, either "FRZ TEMP or REF TEMP" to display the current model type setting, a three digit number in the display.

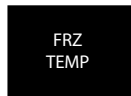

Pressing and releasing either "HIGHER or LOWER" pads will allow you to change model types until you get to the proper three digit number for your unit, see Table 1 on Page 42 Set the correct model code from table below.

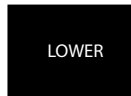

Model code	
Model	Value
5421	342
5481	348

The "REFRIGERATOR and/or FREEZER" indicators will illuminate for each model type as it is selected depending upon the model configuration. (example: code 430 will only illuminate the "REFRIGERATOR" indicator because it is an All Refrigerator)

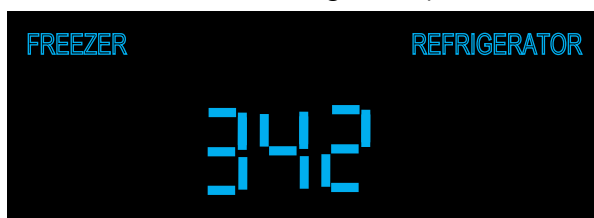

Setting the model code is required whenever the low voltage board is replaced, this will update all of the settings indicated in Table 1 on Page 42 for the model you select. With this setting you can program all necessary settings with one input for the appliance.

### Adjust Freezer Upper Temperature Limit

While in Mode C, press and hold "MAX FRZ" and then hold the "HIGHER" pad for three seconds, this will result in the display changing to "FUL".



Pressing and releasing "HIGHER and LOWER" pads will increase or decrease the set point, which should be set at 7° F.

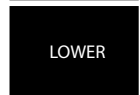

### Adjust Freezer Lower Temperature Limit

While in Mode C, press and hold "MAX FRZ" and then hold the "LOWER" pad for three seconds, this will result in the display changing to "FLL".

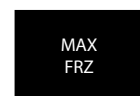



Pressing and releasing "HIGHER and LOWER" pads will increase or decrease the set point, which should be set at -5° F.

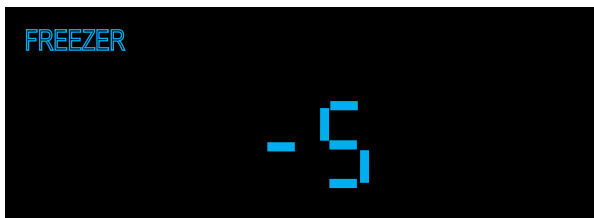

## Adjust Refrigerator Upper Temperature Limit

While in Mode C, press and hold "MAX REF" and then press and hold the "HIGHER" pad for three seconds, this will result in the display changing to "rUL".



Pressing and releasing "HIGHER and LOWER" pads will increase or decrease the set point, which should be set at 47° F.



## Adjust Refrigerator Lower Temperature Limit

While in Mode C, press and hold "MAX REF" and then press and hold the "LOWER" pad for three seconds, this will result in the display changing to "rLL".



Pressing and releasing "HIGHER and LOWER" pads will increase or decrease the set point, which should be set at 33° F.

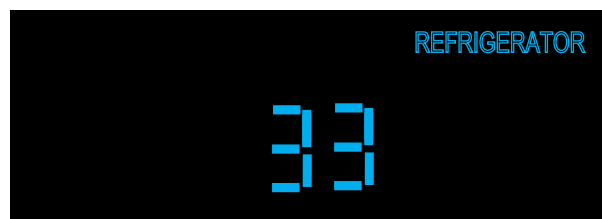

## Defrost lockout adder

This adjustment is not a field adjustment and should not be performed by technicians. This is a factory only adjustment.

If you see "dLA" in the display, immediately exit Mode C by holding "ACTIVATE CONTROLS" for three seconds until you get three audible beeps. Return to your previous actions.

### Defrost start delay

This adjustment is not a field adjustment and should not be performed by technicians. This is a factory only adjustment.

If you see "dSd" in the display, immediately exit Mode C by holding "ACTIVATE CONTROLS" for three seconds until you get three audible beeps. Return to your previous actions.

### Defrost termination delay

This adjustment is not a field adjustment and should not be performed by technicians. This is a factory only adjustment.

If you see "dtd" in the display, immediately exit Mode C by holding "ACTIVATE CONTROLS" for three seconds until you get three audible beeps. Return to your previous actions.

### Constant Evaporator fan mode

This mode only applies to All Refrigerator units and is ignored by any other unit configuration.

### Plant mode

This adjustment is not a field adjustment and should not be performed by technicians. This is a factory only adjustment.

If you see "Pt" in the display, immediately turn power switch to OFF. Turn power back on and start over.

*To exit Mode C and retain any changes made in system up to this point you must press and release "ACTIVATE CONTROLS" one time, the display changes to "Prb". This signifies that the changes were written to the eeprom and that the system has left Mode C and returned to Mode B.*

A black rectangular button with the text "ACTIVATE CONTROLS" in white, uppercase letters.

*The other way to ensure changes have been written into the eeprom is to press and hold "ACTIVATE CONTROLS" for three seconds and you will get three audible tones along with a normal temperature display. This indicates that you have left Mode C and returned to normal operation.*

*Failure to do this will cause system to time out after 10 minutes and any changes will be lost.*

## ALARMS

There are five alarms that signify faulty conditions, they will each be covered in detail.

### 1. High Temp Alarm

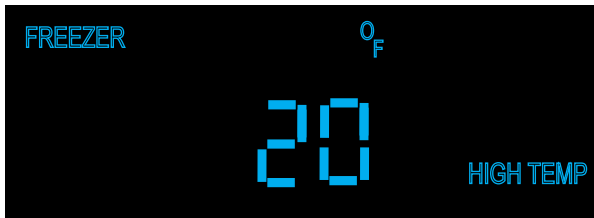

#### *Freezer High Temp alarm*

When the freezer temperature reaches the high temp level (15° F), set in the EEPROM at factory, for a predetermined time (3 hours), also set in EEPROM, the "HIGH TEMP" indicator will come on and the "FREEZER" indicator will flash. You will also get a continuous audible alarm, consisting of a beep pattern (ON - 0.5 sec, OFF 2 sec's).

#### *Refrigerator High Temp alarm*

When the refrigerator temperature reaches the high temp level (50° F), set in the EEPROM at factory, for a predetermined time (3 hours), also set in EEPROM, the "HIGH TEMP" indicator will come on and the "REFRIGERATOR" indicator will flash. You will also get a continuous audible alarm, consisting of a beep pattern (ON - 0.5 sec, OFF 2 sec's).

If the condition(s) change and the unit's temperature(s) are brought back within limits as described above, the audible alarm will turn off. The "HIGH TEMP" and the appropriate zone (Refrigerator or Freezer) indicator will continue to operate as described above.

To cancel the audible alarm when condition first occurs, press and release "ALARM OFF", this will result in shutting off the audible alarm only. To clear the "HIGH TEMP" and flashing zone light (FREEZER or REFRIGERATOR), the temperature must be brought down below the limit temperature as described in the appropriate zone above. Then pressing and releasing "ALARM OFF" once will clear the "HIGH TEMP" off the screen and the zone indicator will stop flashing.

### 2. Open Thermistor Alarm

The controller will sense an open thermistor condition within 15 seconds of power on.

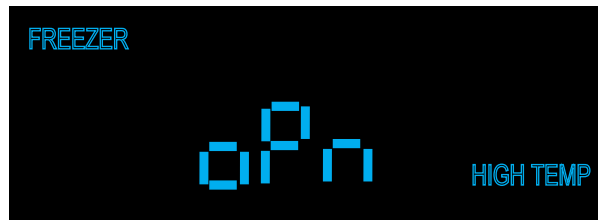

#### *Open Refrigerator Thermistor Alarm*

When the control senses that the refrigerator thermistor is open, "oPn" is displayed on the control along with the zone, "REFRIGERATOR". If the control was in the Freezer zone when the condition occurred, it automatically switches over to the faulty zone ("REFRIGERATOR"). You also receive an audible alarm consisting of five beeps that occurs only one time. The visual alarms as described above will continue until the condition is corrected.

#### *Open Freezer Thermistor Alarm*

When the control senses that the freezer thermistor is open, "oPn" is displayed on the control along with the zone, "FREEZER". If the control was in the Refrigerator zone when the condition occurred, it automatically switches over to the faulty zone ("FREEZER"). You also receive an audible alarm consisting of five beeps that occurs only one time. The visual alarms as described above will continue until the condition is corrected.

The unit will continue to execute temperature control and defrost operations as required until the condition is corrected. The control does this through software programming, acting as if the cut-out temperature is never reached in the faulty zone, temperature control in the other zone is unaffected.

The visual alarms will reset by themselves within 15 seconds of the open thermistor condition being corrected and temperature control reverts back to normal operation.



### 3. Shorted Thermistor Alarm

The controller will sense a shorted thermistor condition within 15 seconds of power on.



#### *Shorted Refrigerator Thermistor Alarm*

When the control senses that the refrigerator thermistor is shorted, "Shr" is displayed on the control along with the zone, "REFRIGERATOR". If the control was in the Freezer zone when the condition occurred, it automatically switches over to the faulty zone ("REFRIGERATOR"). You also receive an audible alarm consisting of five beeps that occurs only one time. The visual alarms as described above will continue until the condition is corrected.

#### *Shorted Freezer Thermistor Alarm*

When the control senses that the freezer thermistor is shorted, "Shr" is displayed on the control along with the zone, "FREEZER". If the control was in the Refrigerator zone when the condition occurred, it automatically switches over to the faulty zone ("FREEZER"). You also receive an audible alarm consisting of five beeps that occurs only one time. The visual alarms as described above will continue until the condition is corrected.

The unit will continue to execute temperature control and defrost operations as required until the condition is corrected. The control does this through software programming, acting as if the cut-out temperature is never reached in the faulty zone, temperature control in the other zone is unaffected.

The visual alarms will reset by themselves within 15 seconds of the open thermistor condition being corrected and temperature control reverts back to normal operation.

### 4. Power Loss Alarm

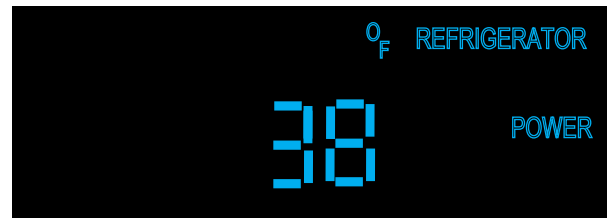

If the control experiences a power loss condition and power is restored, the Power Loss alarm is displayed. This consists of the "POWER" indicator being flashed on and off along with the temperature digits flashing on and off. All other indicators will be off and only "ACTIVATE CONTROLS and ALARM OFF keys are active on the control panel.

There is no audible alarm indication associated with the power loss alarm. Pressing and releasing the "ALARM OFF" pad will result in "POWER" indicator extinguishing and the temperature digits revert back to normal temperature display.

### 5. Door Open Alarm

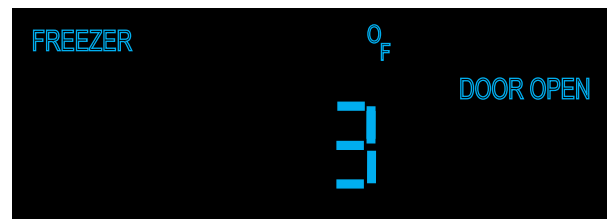

If the control senses that a door is open for a period of time, equal to the door open delay (factory default is 3 minutes, this time can be adjusted in service mode B) a continuous audible alarm will sound. At the same time "DOOR OPEN" illuminates on LED display and will remain on until condition is corrected.

Press the "ALARM OFF" pad and the audible alarm will cease. Pressing and holding the "ALARM OFF" pad for three seconds will disable the audible door alarm, until the "ALARM OFF" pad is again held for three seconds which will enable the audible door alarm once again.

These actions will not clear the visual "DOOR" alarm, that can only be cleared by shutting the doors and allowing the control to reset it.

**TABLE 1 - Model types**

Model Type	Model Code	VCC Freq Low HZ	REF Offset °F	FRZ Offset °F	REF Cut-In °F	REF Cut-out °F	FRZ Cut-In °F	FRZ Cut-out °F	REF user default temp	REF user default temp
BM36	136	65	-9	0	6	-6	7	-8	38	0
SxS42	342	75	-6	-2	6	-6	7	-7	38	0
SxS42D	242	75	-8	4	6	-6	7	-7	38	0
SxS48	348	75	-4	-5	6	-6	7	-7	38	0
SxS48D	248	75	-8	1	6	-6	7	-7	38	0
AF30	530	75		-2			7	-8	38	0
AF36	536	75		1			6	-6	38	0
AR30	430	75	-6		6	-6			38	0
AR36	436	65	-5		6	-6			38	0

## Door Stop Adjustment

Your refrigerator is factory set at 110° door stop position. To change to either the 90° or 120° position, remove the door stop pin located in the bottom hinge using a 3/16" allen wrench. For 120° swing, move the pin to stop hole closest to the unit. For 90° swing, move pin to stop hole farthest from the unit.

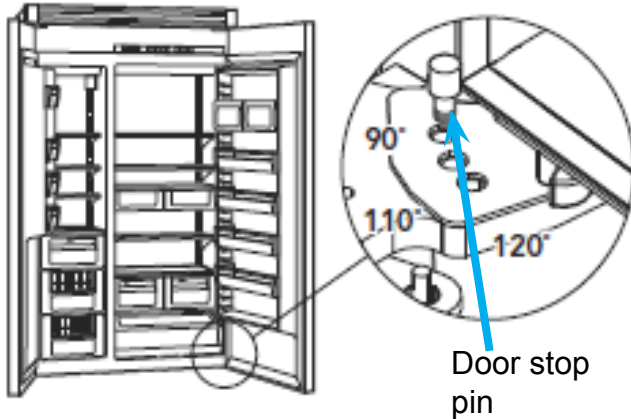

## Light Bulb

Disconnect power at breaker or turn power disconnect switch to the off position. Lightly grasp light cover with both hands and pull down. Replace bulb with an incandescent, medium base tubular bulb with a maximum of 40 watts. Replace cover by engaging light bracket with the back fingers on the light cover. Once engaged, snap the front fingers on the light cover.

Note: The clear section of the light cover is considered the back section. Reconnect power or turn power disconnect switch to the "ON" position.

## Door Hinge Adjustment

Removal of the upper grill assembly allows access to door hinge for adjustment.

To remove upper grill:

1a. (Professional) Lift center grille louver up and pull out.

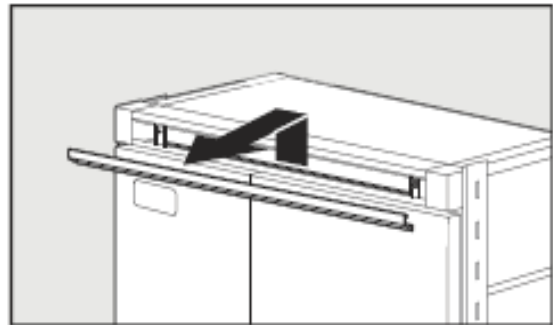

1b. (Designer) Pull the center grille louver up at an angle and pull out.

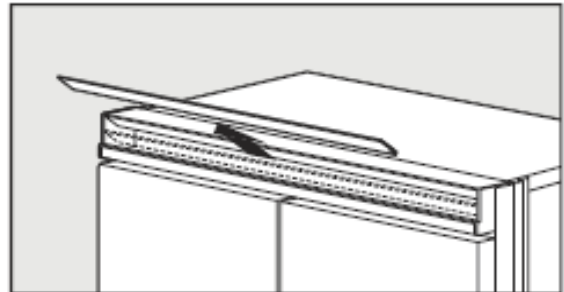

2. Using an 8" magnetic nut driver, remove the two 1/4" screws.

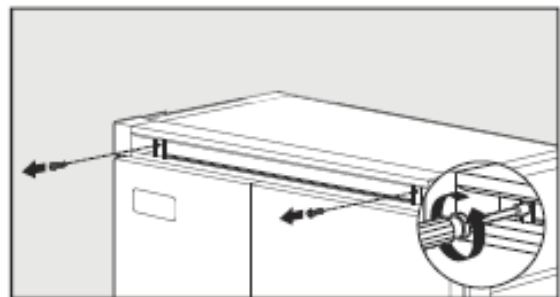

3. Remove grille assembly.

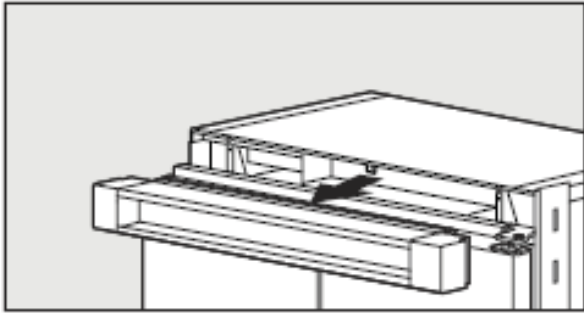

4. Remove four side screws and remove unit top.

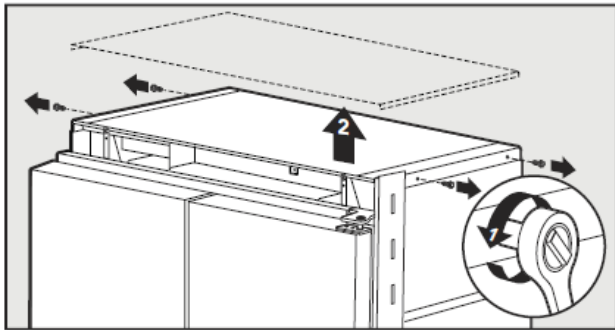

5. Loosen the four hinge screws. Adjust door.

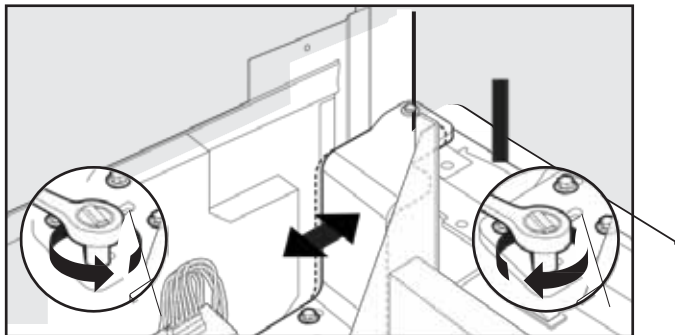

6. Reverse procedure for reinstallation.

## Height Adjustment

Removal of the kickplate allows access to rollers and stabilizing legs for height adjustment.

1. Remove lower kickplate screws using a Phillips screwdriver.

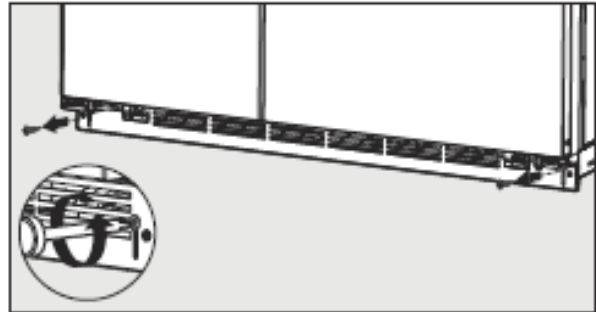

2. Remove upper kickplate screws using a Phillips screwdriver. Remove kickplate assembly.

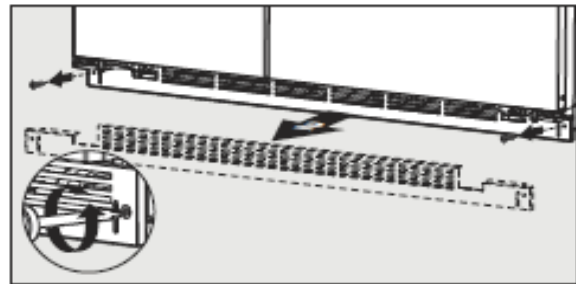

3. Using a 5/16" head wrench, turn the front (F) adjustment screws to raise or lower the front of the refrigerator.

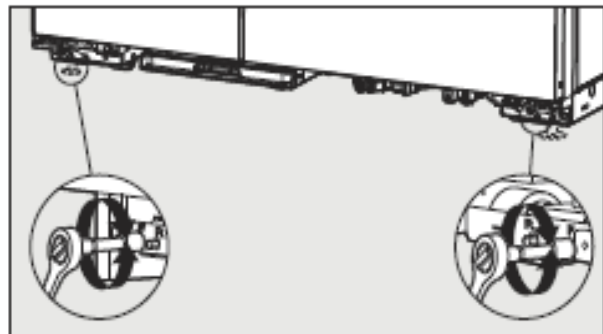

Note: DO NOT use an electric device. Over tightening can cause damage.

- Using a 5/16" head wrench, turn the rear (R) adjustment screws to raise or lower the rear of the refrigerator.

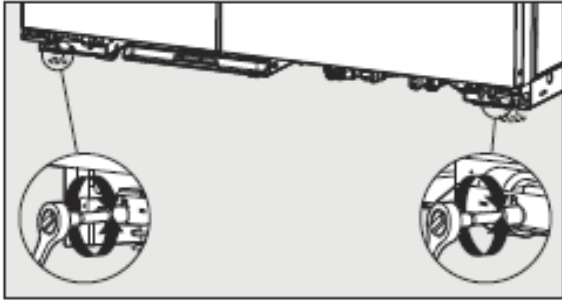

Note: DO NOT use an electric device. Overtightening can cause damage.

- Reinstall kickplate.



## WARNING

To avoid risk of electrical shock, personal injury, or death, disconnect electrical power source to unit, unless test procedures require power to be connected. Discharge capacitor through a resistor before attempting to service. Ensure all ground wires are connected before certifying unit as repaired and/or operational.

### VCC3 Inverter Diagnostic Codes

Code	Compressor Status	Possible Fault	Service Action
1 Flash (every 15 seconds)	ON	1. No failure detected	<ul style="list-style-type: none"> <li>If system is not working properly, check other refrigeration components.</li> </ul>
	OFF	<ol style="list-style-type: none"> <li>No signal from control board</li> <li>Open Thermistor</li> </ol>	<ul style="list-style-type: none"> <li>If refrigerator settings (thermistor conditions) are at levels in which the compressor should be "ON".</li> <li>Unplug inverter from power supply and wait for 2 minutes, reconnect the inverter to the power supply and wait for 12 minutes.</li> <li>If inverter still shows 1 flash code and compressor is OFF, then check the control board.</li> </ul>
2 Flashes (every 5 seconds)	OFF	1. No signal from the control board	<ul style="list-style-type: none"> <li>Check frequency cable connection</li> <li>If frequency cable connection is good, replace inverter.</li> </ul>
3 Flashes (every 5 seconds)	OFF	<ol style="list-style-type: none"> <li>Compressor / inverter cable open circuit</li> <li>Compressor winding open circuit</li> </ol>	<ul style="list-style-type: none"> <li>Check compressor/inverter cable connection</li> <li>Check compressor winding resistances (among the 3 terminal hermetic pins)</li> <li>If resistances are within specifications and compressor/inverter cable is OK, replace inverter.</li> </ul>
4 Flashes (every 5 seconds)	OFF	1. Compressor damaged / system damaged	<ul style="list-style-type: none"> <li>Check compressor input power</li> <li>Check compressor winding resistances</li> <li>Check leakage current between hermetic terminal pins and compressor shell.</li> <li>If resistance or leakage current is out of spec, replace the compressor.</li> <li>If resistance and leakage current are within spec, check inverter/compressor cable for open circuit.</li> <li>Unplug inverter from power supply and wait for 2 minutes, reconnect the inverter to the power supply and wait for 12 minutes.</li> <li>If inverter still shows 4 flash code and compressor is OFF, replace the compressor.</li> </ul>
No Flash	OFF	<ol style="list-style-type: none"> <li>No input power</li> <li>Inverter damaged</li> </ol>	<ul style="list-style-type: none"> <li>Check the input power (115V)</li> <li>If there is no signal, check input power connections</li> <li>If voltage is within specs, unplug inverter from power supply and wait for 2 minutes, reconnect the inverter to the power supply and wait for 12 minutes.</li> <li>If inverter still shows no flash code and compressor is OFF, change the inverter.</li> <li>If the inverter shows no flash code and the compressor is ON, diagnostic function is not working properly.</li> </ul>

**⚠ WARNING**

To avoid risk of electrical shock, personal injury, or death, disconnect electrical power source to unit, unless test procedures require power to be connected. Discharge capacitor through a resistor before attempting to service. Ensure all ground wires are connected before certifying unit as repaired and/or operational.

## High Voltage Board

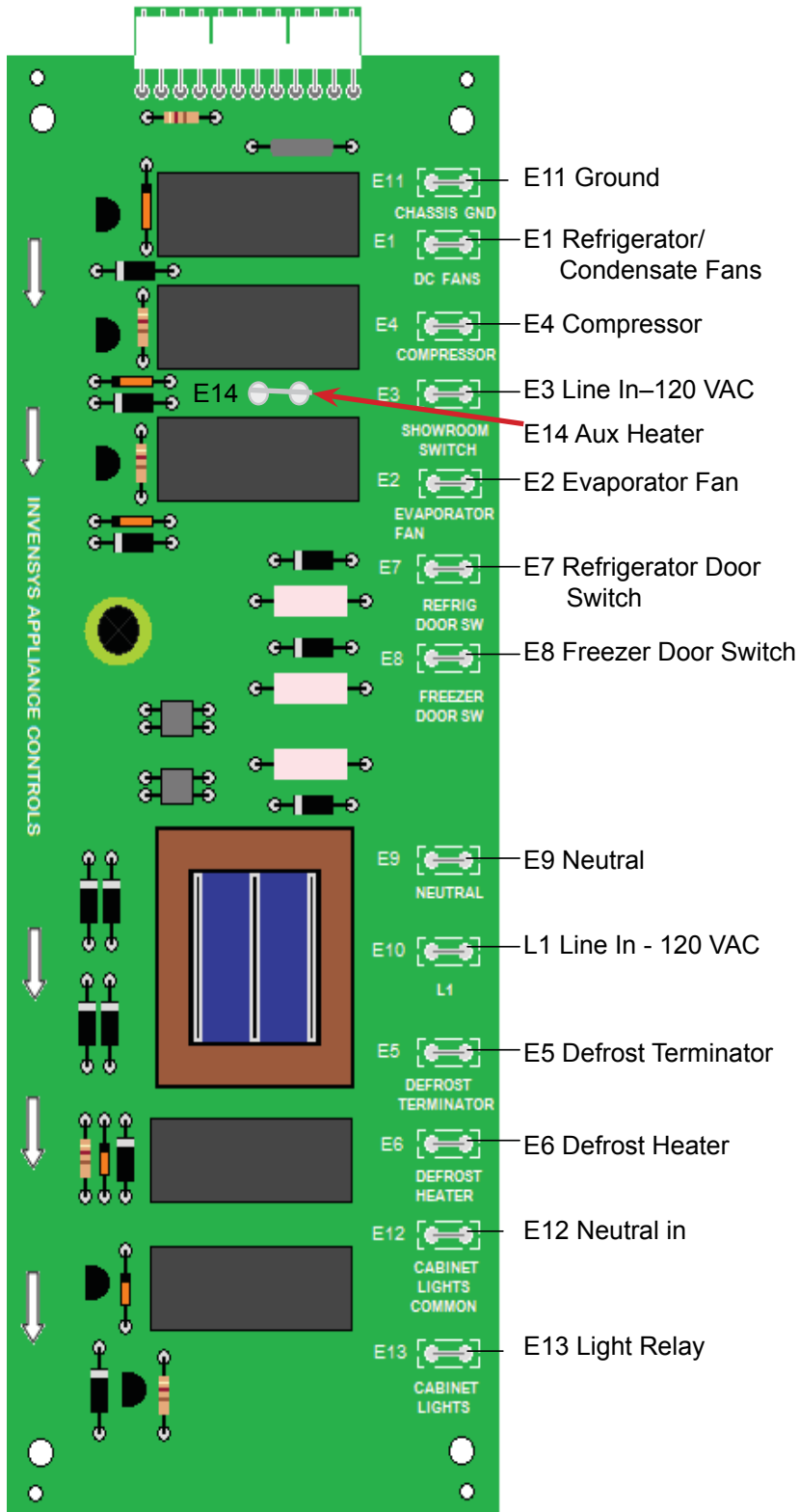

High Voltage Board		
Component	Test Point	Reading
Refrigerator/Condensate Fans	E1-E11	24 VDC
Evaporator Fans	E2-E11	115 VAC
L1	E3-E11	115 VAC
Compressor / Condenser Fan	E4-E11	115 VAC
Defrost Terminator (closed)	E5-E11	0 VAC
Defrost Terminator (open)	E5-E11	115 VAC
Defrost Heater	E6-E11	115 VAC
Ref door switch (top right light)	E7-E11	115 VAC
Freezer door switch (left light)	E8-E11	115 VAC
Neutral In	E9-E11	N/A
Line In	E10-E11	115 VAC
Ground	E11	N/A
Neutral In (lights)	E12-E11	N/A
Neutral Out (lights)	E13-E11	115 VAC
Aux Heater (Dispenser units only)	E14-E11	115 VAC

## ⚠ WARNING

To avoid risk of electrical shock, personal injury, or death, disconnect electrical power source to unit, unless test procedures require power to be connected. Discharge capacitor through a resistor before attempting to service. Ensure all ground wires are connected before certifying unit as repaired and/or operational.

### Low Voltage Board

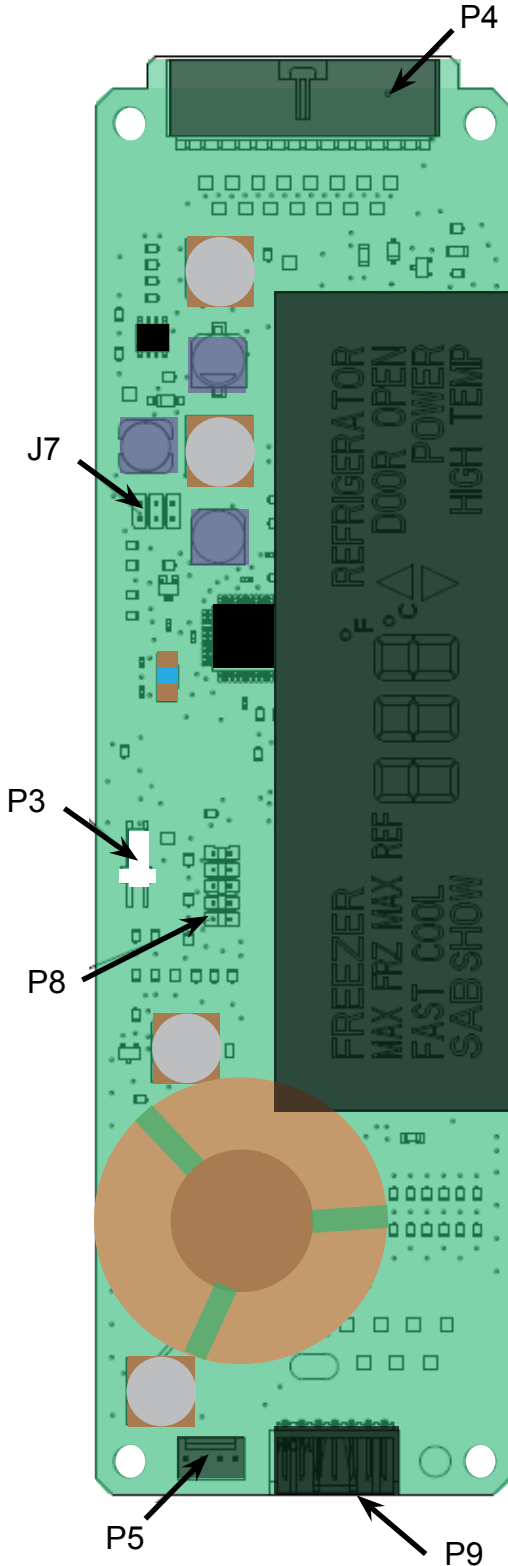

Pin location	Function	Voltage range	Signal
P4-1	Dc supply to thermistors	4.5 - 5.5 VDC, ref to P4-12	DC
P4-2	Freezer thermistor input	0 - 5.5 VDC, ref to P4-12	DC
P4-3	Refrigerator thermistor input	0 - 5.5 VDC, ref to P4-12	DC
P4-4	Provide zero timing	26 V p-p to 34V p-p, ref P4-12	See Note 1 below
P4-5	DC Fan enable	17.8 vdc - 38 vdc, ref to chassis grnd.	DC
P4-6	Defrost termination	17.8 vdc - 38 vdc, ref to chassis grnd.	See Note 2 below
P4-7	Evaporator fan enable	17.8 vdc - 38 vdc, ref to chassis ground	See Note 2 below
P4-8	Compressor enable	17.8 vdc - 38 vdc, ref to chassis ground	See Note 2 below
P4-9	Defrost termination signal	25.8 vdc - 38 vdc, ref to chassis grnd	See Note 2 below
P4-10	Door signal	25.8 vdc - 38 vdc, ref to chassis grnd	See Note 2 below
P4-11	PS Reference	0 vdc	DC
P4-12	-30 vdc	22.8 vdc - 38 vdc, ref to chassis ground	See Note 2 below
P4-13	Not used		AC
P4-14	Not used		AC
P4-15	Light enable relay	17.8 vdc - 38 vdc, ref to chassis ground	See Note 2 below

**NOTE 1** : Requires an oscilloscope to measure

**NOTE 2** :DC voltage- load of meter can affect measurement



## **WARNING**

To avoid risk of electrical shock, personal injury, or death, disconnect electrical power source to unit, unless test procedures require power to be connected. Discharge capacitor through a resistor before attempting to service. Ensure all ground wires are connected before certifying unit as repaired and/or operational.

### Troubleshooting Guide

Below and on the following page are some general guides should a problem be detected. Please refer to the test procedures in this manual to determine the defective component.

Problem	Probable Cause	Correction
Unit will not operate	Power supply Circuit breaker Power switch	Verify voltage Reset breaker Turn to the "ON" position
Water overflows defrost pan	Unit not level Float switch Pan heater	Ensure unit is level Verify operation of float Verify heater is working
Ice maker will not operate	Freezer too warm Shut off arm Water valve Water supply	Verify freezer temperature Verify the arm is in the "ON" position Verify valve operation Verify water supply
Refrigerator too warm	Door opening Warm food placed in unit Control setting Door seal Airflow Refrigerator fan	Minimize door openings Allow temperatures to stabilize Move control to medium setting Verify closure, replace if needed Ensure airflow is not obstructed Verify movement/operation of fan
Refrigerator too cold	Temperature setting Control board Airflow	Move control to medium setting Verify proper operation Verify airflow is proper
Freezer too warm	Control setting Door seal Dirty condenser Control board	Move control to medium setting Verify closure, replace if needed Clean condenser coil Verify operation
Freezer too cold	Temperature setting Defrost thermostat Control board	Move to medium setting Verify thermostat is closing Verify operation
Unit runs continually	Control setting Door seal Dirty condenser Condenser/evaporator fan Control board Freezer thermistor	Move to medium setting Verify closure, replace if needed Clean condenser coil Verify movement/operation of fan Verify operation Verify thermistor is not shorted
Frost on evaporator	Defrost thermostat Evaporator fan Defrost heater	Verify thermostat is closing Check connection and possible short open condition
Unit running and no lights	Sabbath Mode Open circuit	Verify operation of Sabbath Mode Repair/replace wiring

## **WARNING**

To avoid risk of electrical shock, personal injury, or death, disconnect electrical power source to unit, unless test procedures require power to be connected. Discharge capacitor through a resistor before attempting to service. Ensure all ground wires are connected before certifying unit as repaired and/or operational.

<i><b>Ice Problems</b></i>	<i><b>Action</b></i>
Jammed cubes (small or oversized cubes)	Adjust fill level or level ice maker or refrigerator
Hollow cubes	Adjust low fill or remove restrictions in supply line Level ice maker or refrigerator Remove obstructions to air flow at fill end so it freezes before thermostat end
Ice build-up on ejector blades	Usually caused by hollow cubes See hollow cubes above Remove ice maker, thaw out
Cubes falling back into mold during ejection	Check if fill cup is displaced and blocking ice Fix fill cup or replace ice maker
Cubes falling over back of ice maker	Check if fill cup is displaced and blocking ice Fix fill cup or replace ice maker
<i><b>Power Problems</b></i>	<i><b>Action</b></i>
No power to ice maker at connector socket	Determine discontinuity by tracing power
No power to water valve	Determine discontinuity by tracing power
<i><b>Water Problems</b></i>	<i><b>Action</b></i>
No water to refrigerator	Turn on supply Look for obstructions in supply line or valve
No water to ice maker	Look for obstructions in water valve or fill tube
Clogged water valve	Clean or replace water valve depending on type
Insufficient water to ice maker (with correct fill time)	Check for restrictions in supply line and valve, especially saddle valves
Low water pressure at supply	Increase water pressure to 20 – 120 PSI
Low water pressure at water valve	Look for restrictions in line
Excessive water pressure	Install pressure regulator and set to 60 PSI
Low water fill volume	Adjust water fill screw, clear obstructions in supply line or supply valve, or replace water valve
Excessive water fill volume	Adjust water fill screw, reduce water pressure, or replace water valve
Water overflows fill cup	Reposition fill-tube in fill cup or remove obstruction in fill cup
Water overflows mold	Adjust water fill screw, level ice maker or refrigerator, reduce water pressure, or replace water valve or ice maker
Leaky water valve	Tighten connections or replace water valve
<i><b>Temperature Problems</b></i>	<i><b>Action</b></i>
Freezer too warm	Adjust freezer setting or repair refrigerator

**WARNING**

To avoid risk of electrical shock, personal injury, or death, disconnect electrical power source to unit, unless test procedures require power to be connected. Discharge capacitor through a resistor before attempting to service. Ensure all ground wires are connected before certifying unit as repaired and/or operational.

<i>Ice maker Problems</i>	<i>Action</i>
Raised shut-off arm	Lower shut-off arm to "ON" position
Broken or bent shut-off arm	Repair arm or replace ice maker
Shut-off arm stuck or obstructed	Remove obstruction
Ice maker not level	Check level of refrigerator first, then level ice maker
Can't level ice maker	Level refrigerator first, then try again
Open thermostat (won't close below 17°F)	Replace thermostat
Closed thermostat (won't open above 32°F)	Replace thermostat
Thermostat out of calibration	Replace thermostat
Heater not staked in mold	Replace ice maker
Won't cycle test with power available	Replace ice maker
Won't eject ice with power available	Replace ice maker

## Wiring and Component Testing

### High Voltage Board

Terminal	Terminal	Description	- V
1	12	Fresh Food Fan	3.2 m
2	3	Defrost Heater	30.3
10	8	Freezer Fan -120 VAC	28.0
4	11	Defrost Bimetal	0 or ∞
5	*	Line in from freezer door switch	0 or 120 V
7	*	Line out to Inverter board	0 or 120 V
8	*	Line out to Condenser fan motor	0 or 120 V
9	*	Line in from the fresh food door switch	0 or 120 V
13	*	Neutral OUT to cavity lights	N/A

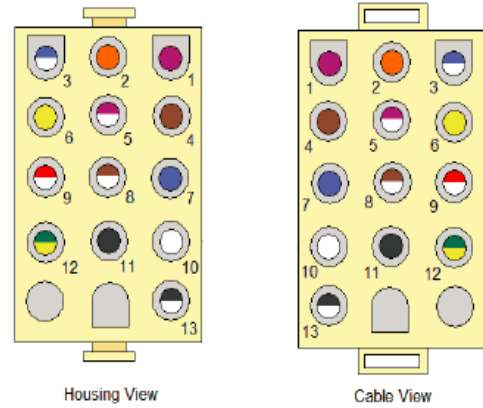
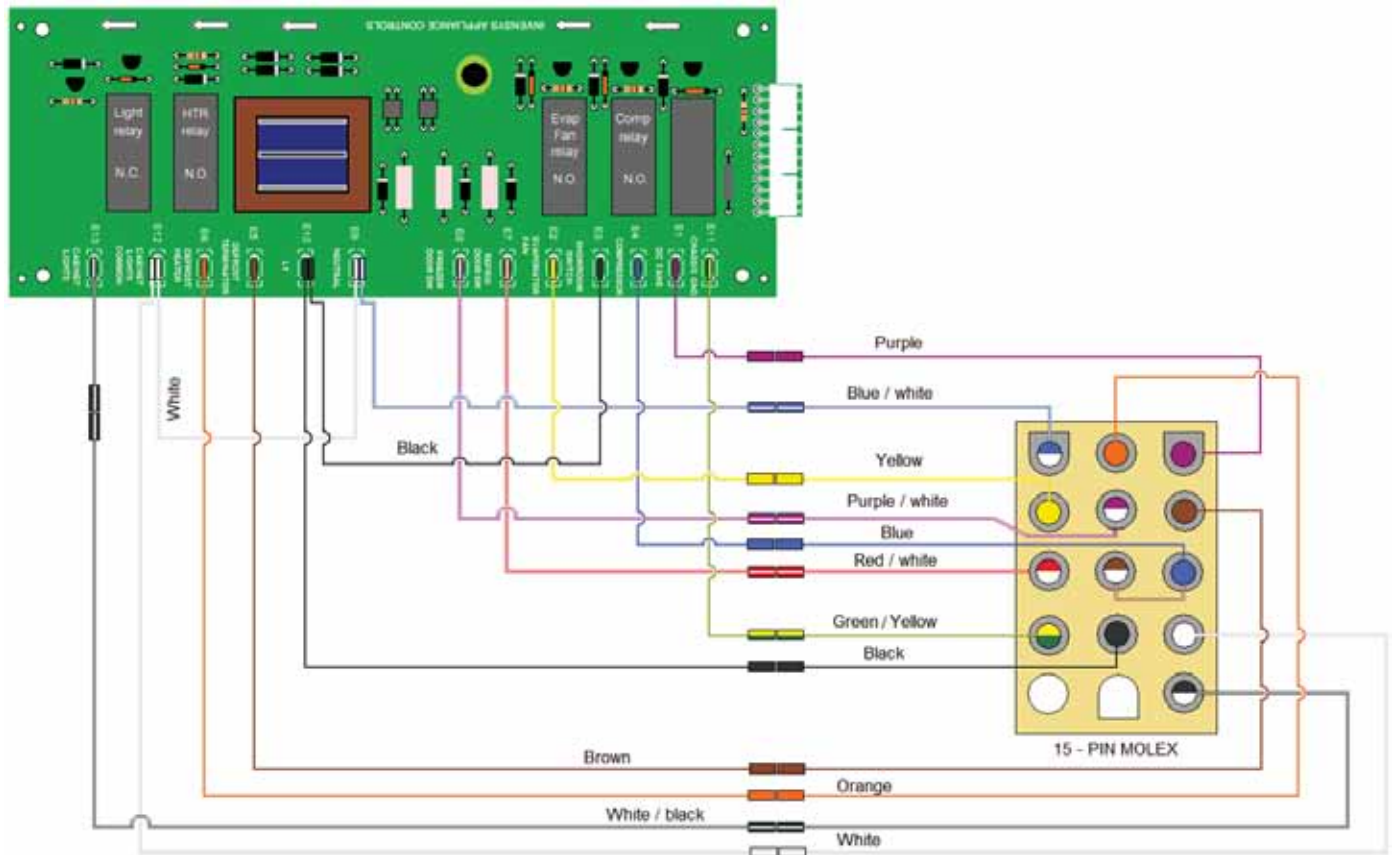
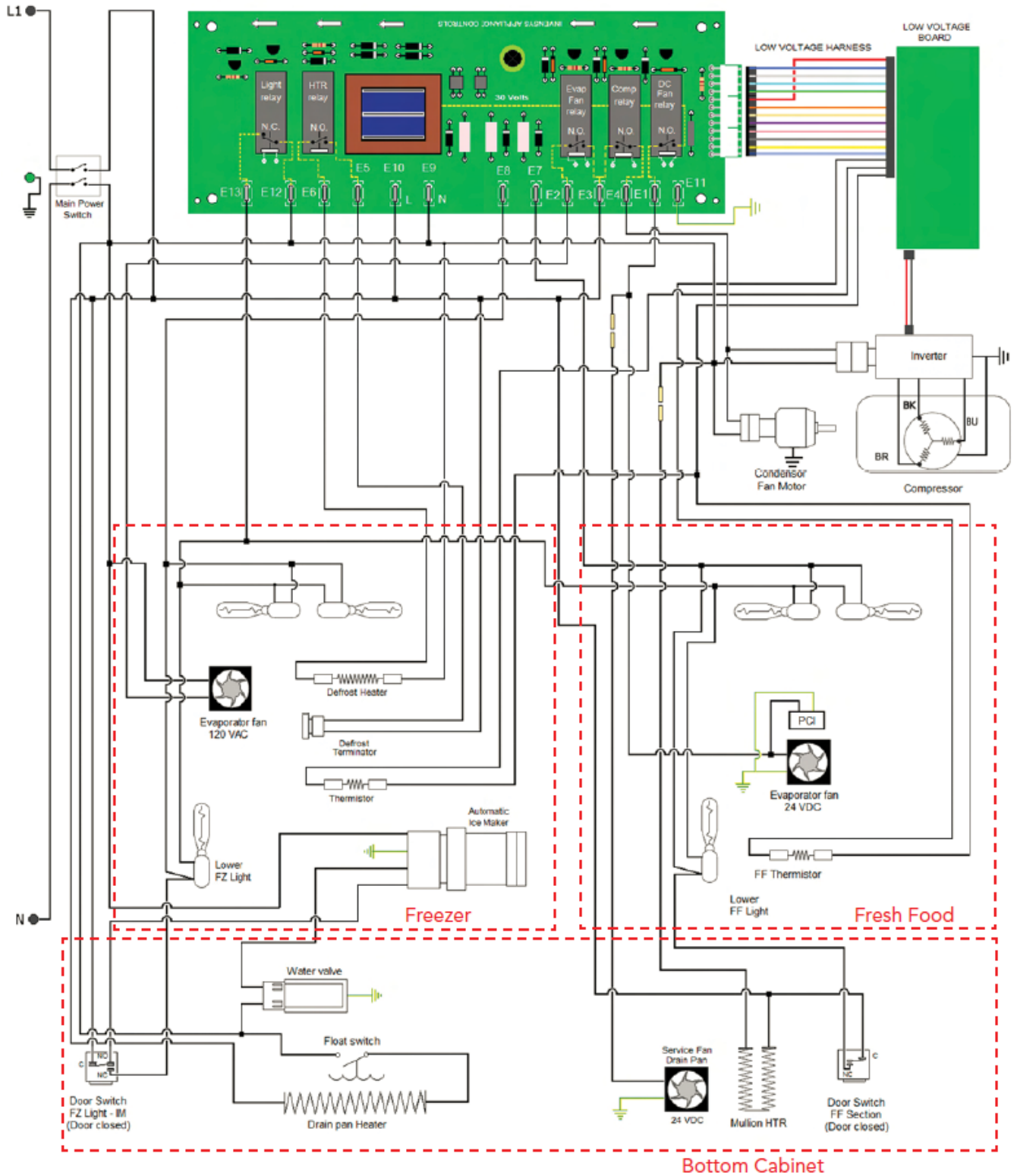

Chart for cable view layout



Side by Side schematic



# Wiring Diagrams



## Side by Side Wiring Diagram

