

Electronic Refrigerator Diagnostics

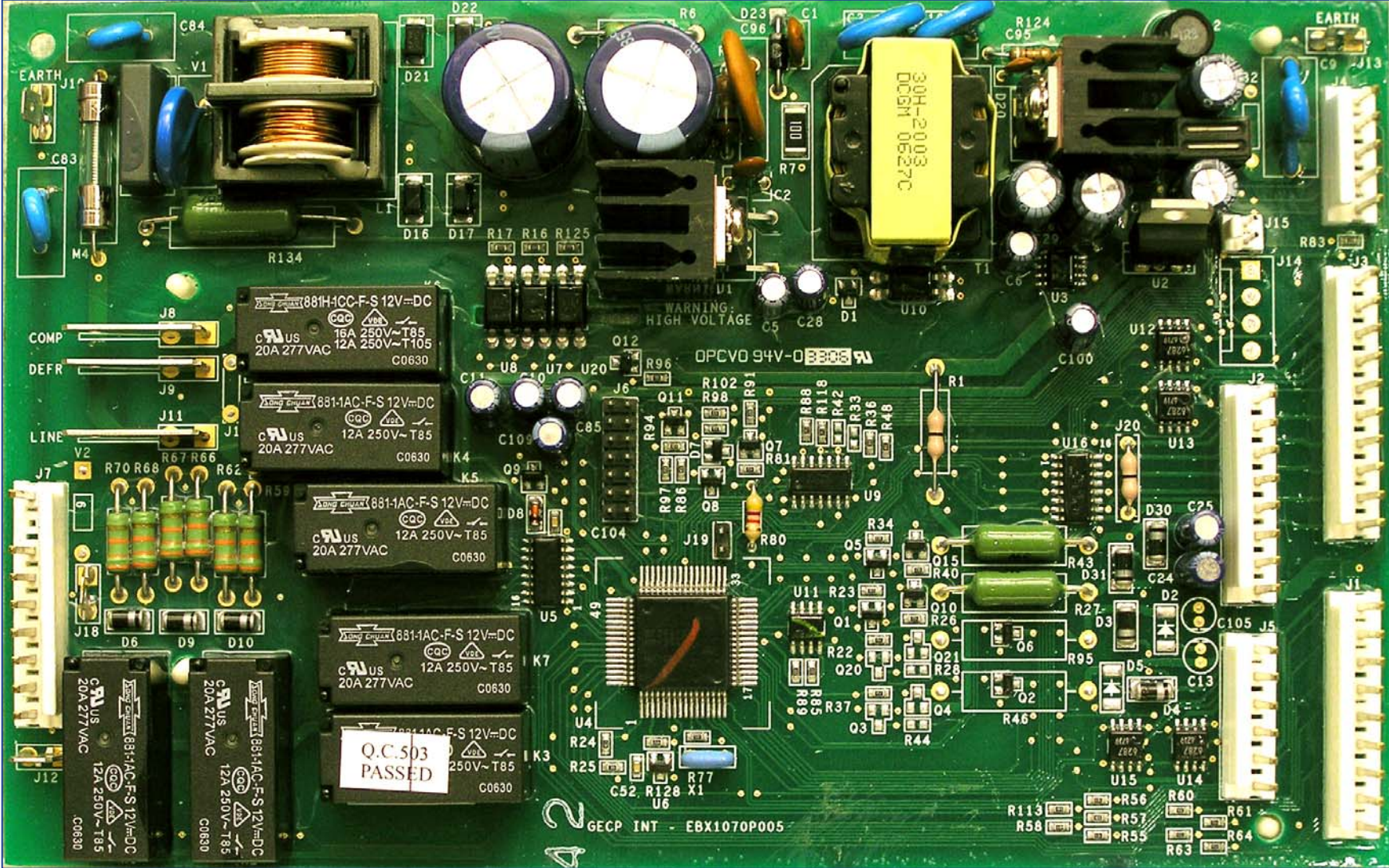

IMPORTANT SAFETY NOTICE

The information in this presentation is intended for use by individuals possessing adequate backgrounds of electrical, electronic, & mechanical experience. Any attempt to repair a major appliance may result in personal injury & property damage. The manufacturer or seller cannot be responsible for the interpretation of this information, nor can it assume any liability in connection with its use.

WARNING

To avoid personal injury, disconnect power before servicing this product. If electrical power is required for diagnosis or test purposes, disconnect the power immediately after performing the necessary checks.

RECONNECT ALL GROUNDING DEVICES

If grounding wires, screws, straps, clips, nuts, or washers used to complete a path to ground are removed for service, they must be returned to their original position & properly fastened.

Main Electronic Board

Caution: When servicing or testing in the main board area, many components and connections are electrically hot to ground. Be sure to use proper service procedures and protective devices.

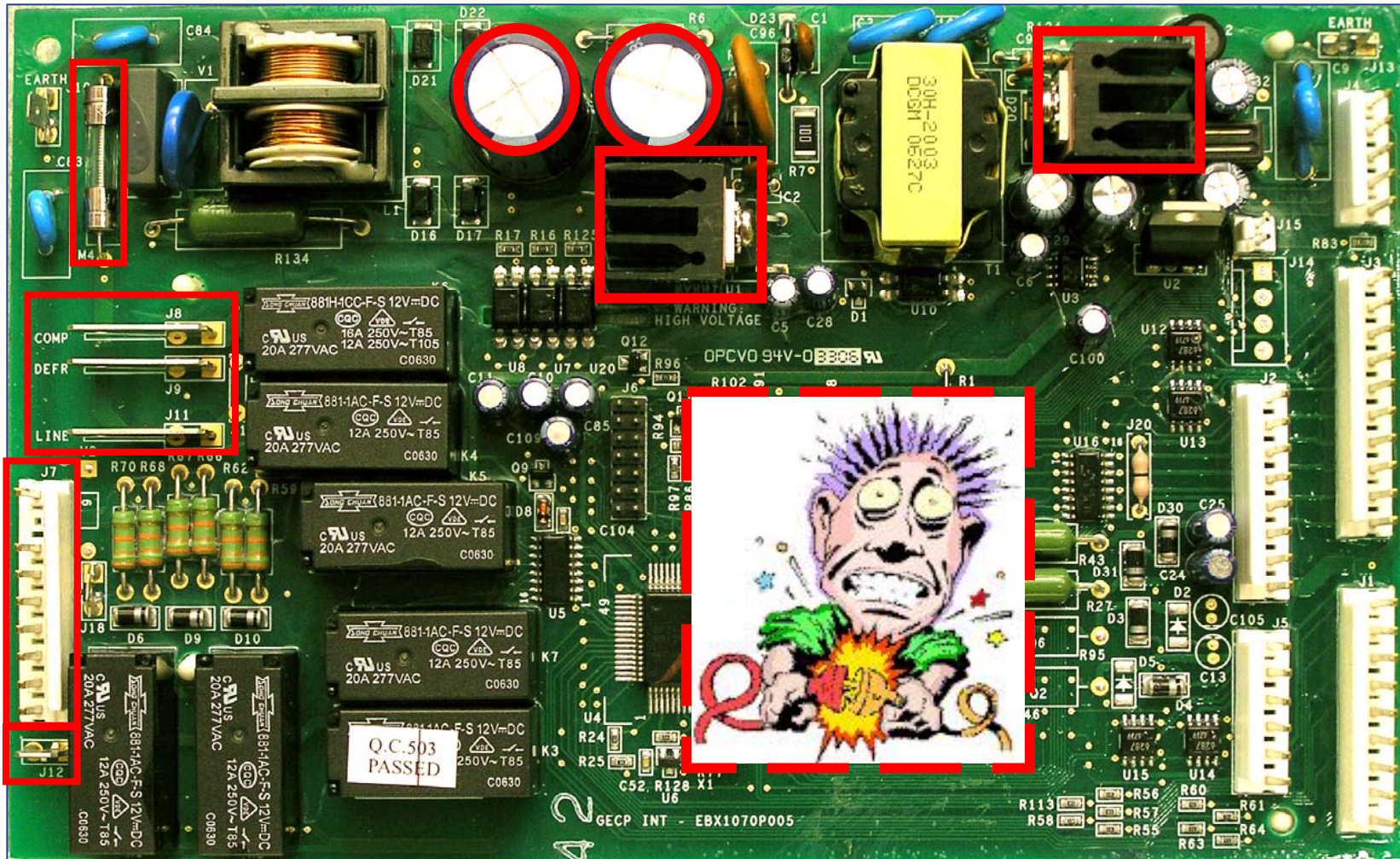

Electronic Diagnostic Test Mode

All the GE electronic refrigerators have a Diagnostic Mode that is incorporated in the software in each main electronic board. This Diagnostic Mode will test certain components and operate others.

To activate this diagnostic test feature on an electronic refrigerator, you will need a touch pad control with at least 5 key pads; otherwise you will have to install the additional diagnostic tool.

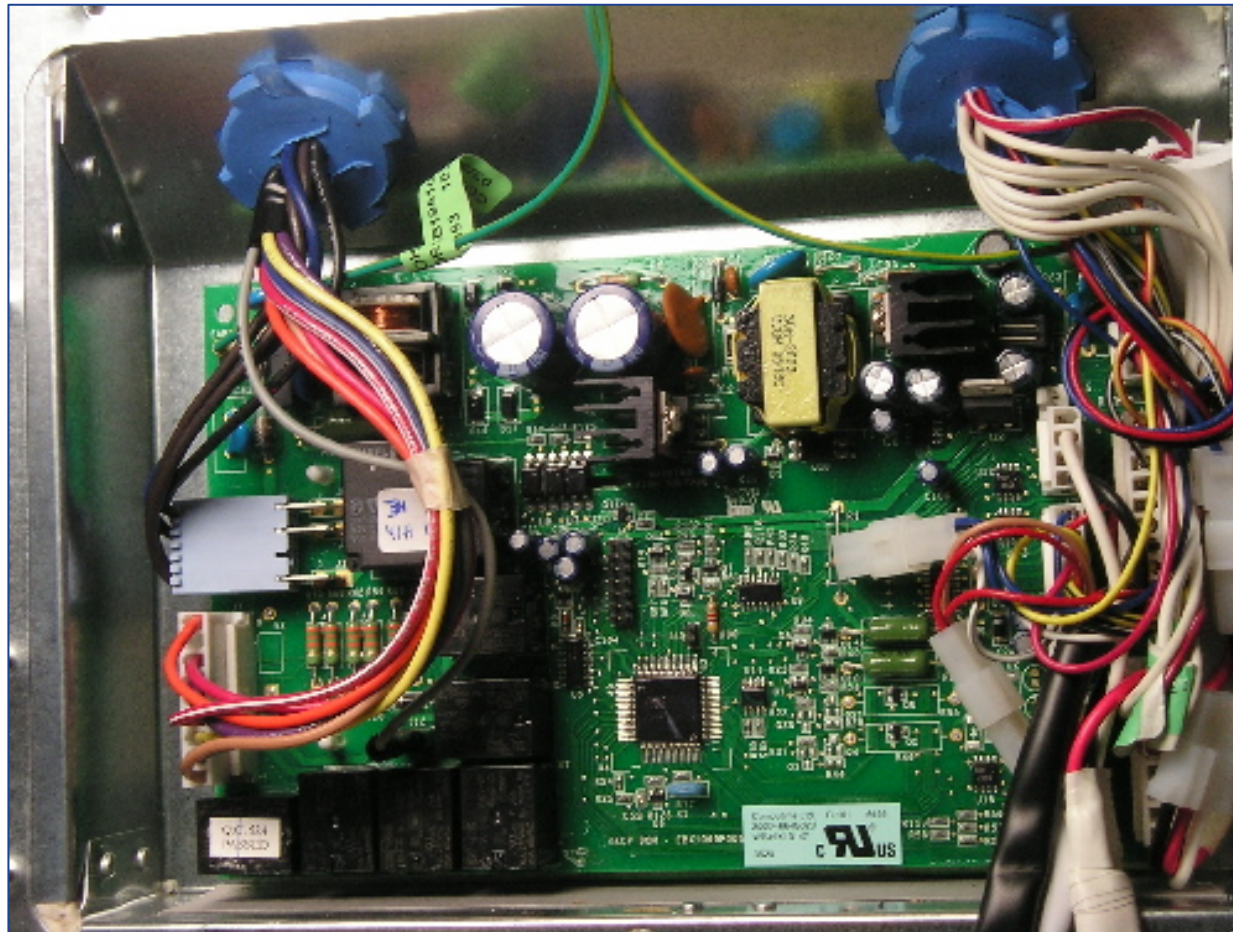

imagination at work

Diagnostics Aid Kit

The diagnostic aid kit may assist the technician to functionally test individual components.

A diagnostic aid kit can be assembled and consists of a key pad temperature control assembly and wire harness. The parts required are WR55X10390 and WX05X14999.

Using the kit, diagnostics can be performed by removing the base grill and plugging into the diagnostic aid wire harness located on the left side. Diagnostics can also be performed by accessing the main board on the back of the refrigerator and plugging into the harness extended from the board.

Note: After plugging in the diagnostic aid kit, if the display is blank, press and release any of the temperature pads. The display will show actual temperatures.

Diagnostic Aid - Front Access



Diagnostic Aid - Main Board Access

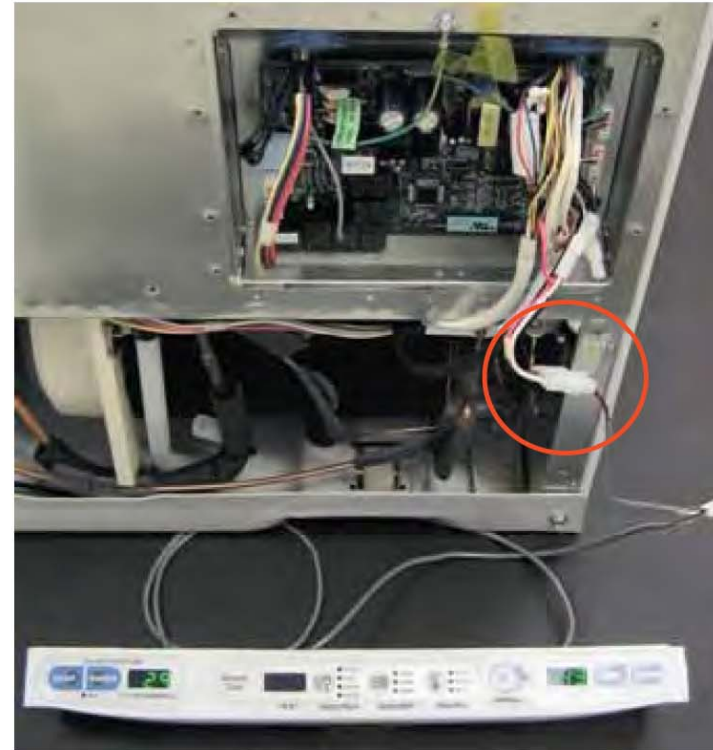

Electronic Diagnostic Test Mode

Control Diagnostics

Enter the diagnostic mode by pressing both the freezer temperature (COLDER and WARMER) pads and the refrigerator temperature (COLDER and WARMER) pads simultaneously. All four pads must be held for approximately 3 seconds. Blinking "0"s in both displays indicate the refrigerator has entered the test mode.

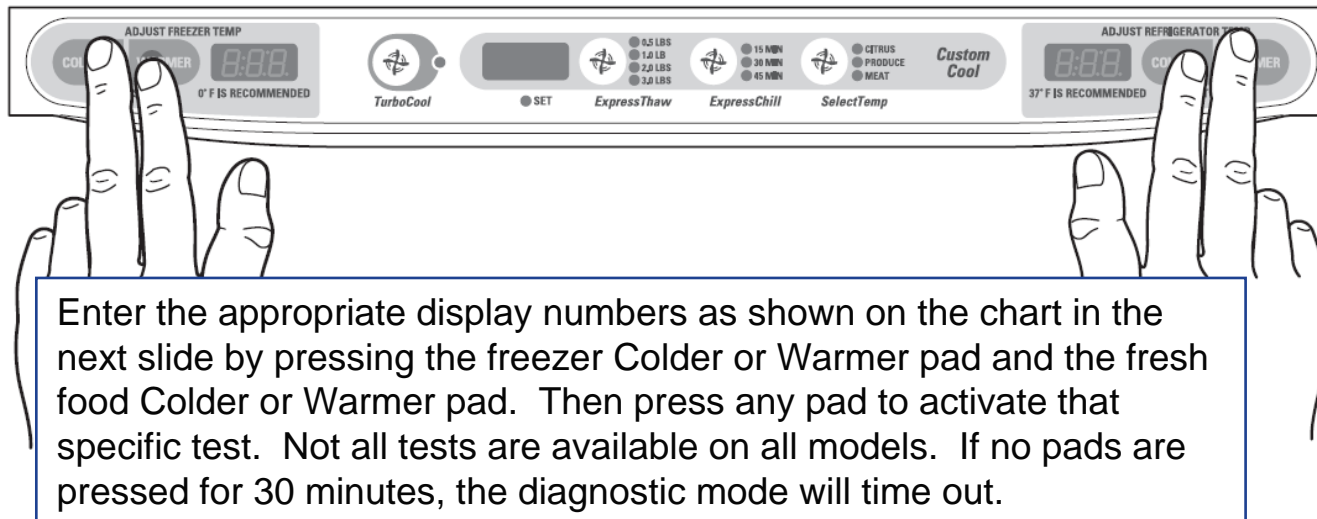

Electronic Diagnostic Test Mode

Freezer Display	Fresh Food Display	Diagnostics	Results	Comments
0	7	Control and Sensor System Test	Checks each thermistor in order.	See Note 1.
1	0	Dampers Test	Custom Cool™ damper will open, close after 10 seconds, pause briefly, then single damper will open for 10 seconds.	Test will not start for approximately 20 seconds after pad is depressed.
1	1	Fan Test	Cycles through each fan for 5 seconds.	
1	2	100% Run Time	Sealed system on 100% of the time. Times out after 1 hour.	
1	4	Defrost Test	Toggles on the defrost cycle. See Note 2.	Must press again to turn heater off. See Note 2.
1	5	Main Control Reset/Test Exit	Causes a system reset and exits test mode.	

This test will not indicate failure for thermistors out of spec

This test will also cycle the FF damper on single evap models

This test will attempt to turn ON the compressor if it is OFF

Note 1: Display order is #1 = Fresh Food Evaporator Thermistor, #2 = Fresh Food Thermistor, #3 = CustomCool™ Thermistor, #4 = Freezer Evaporator Thermistor, #5 = Freezer Thermistor.

Thermistor test results are: P = Pass, 0 = Fail, S = Short to 5 VDC, B = Defective board (replace main control).

Note 2: You **must** enter the defrost test again to toggle the defrost heater off at the end of the test. The heater will not come on if the evaporator thermistor is above 70°F (21°C).

Main Electronic Board

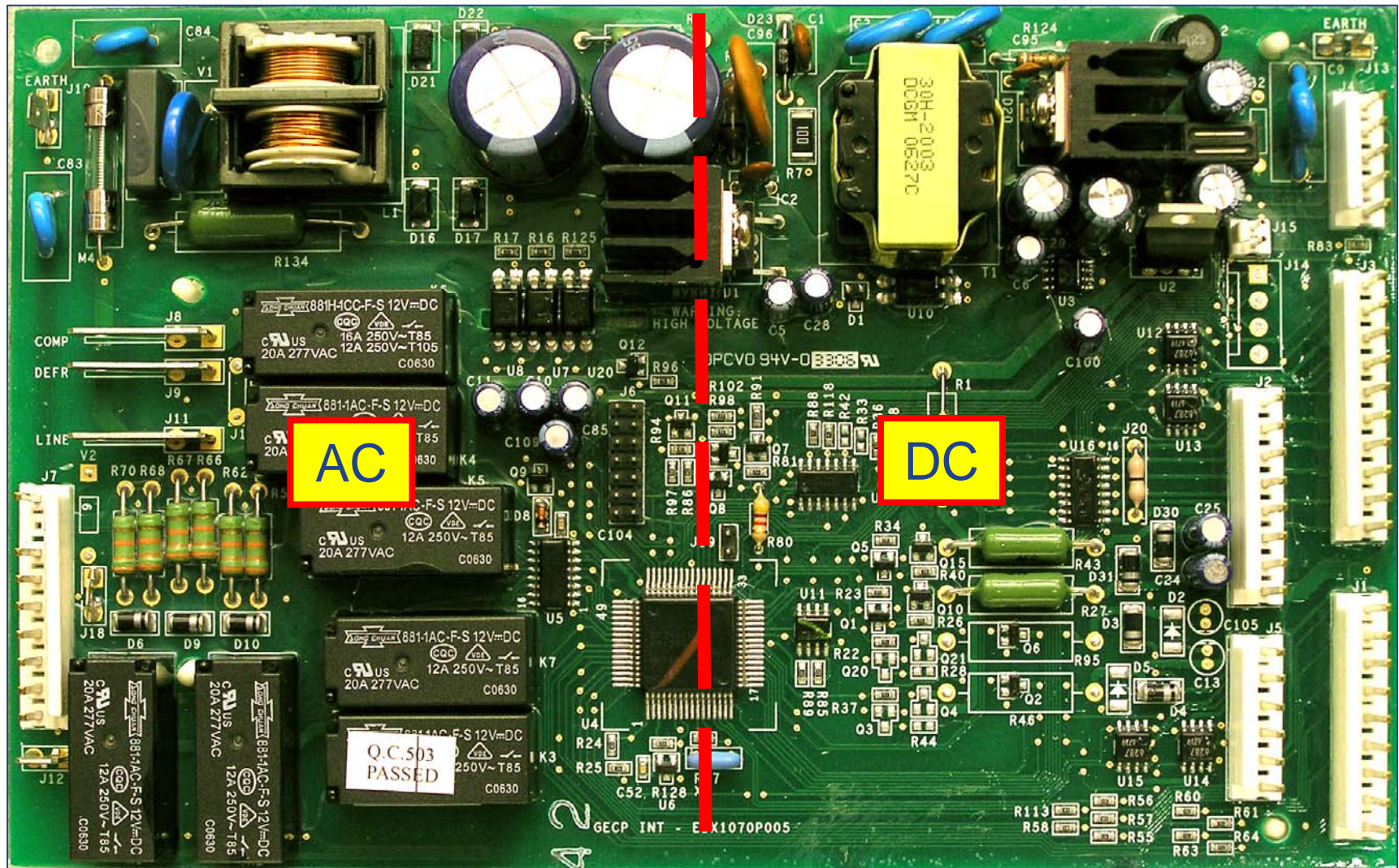

The main board outputs both AC and DC voltages to the refrigerator components. The one half of the board is AC inputs and outputs; while the other half of the board is DC inputs and outputs.

Note: Wiring connectors are not shown for a better view of the board.

Main Electronic Board

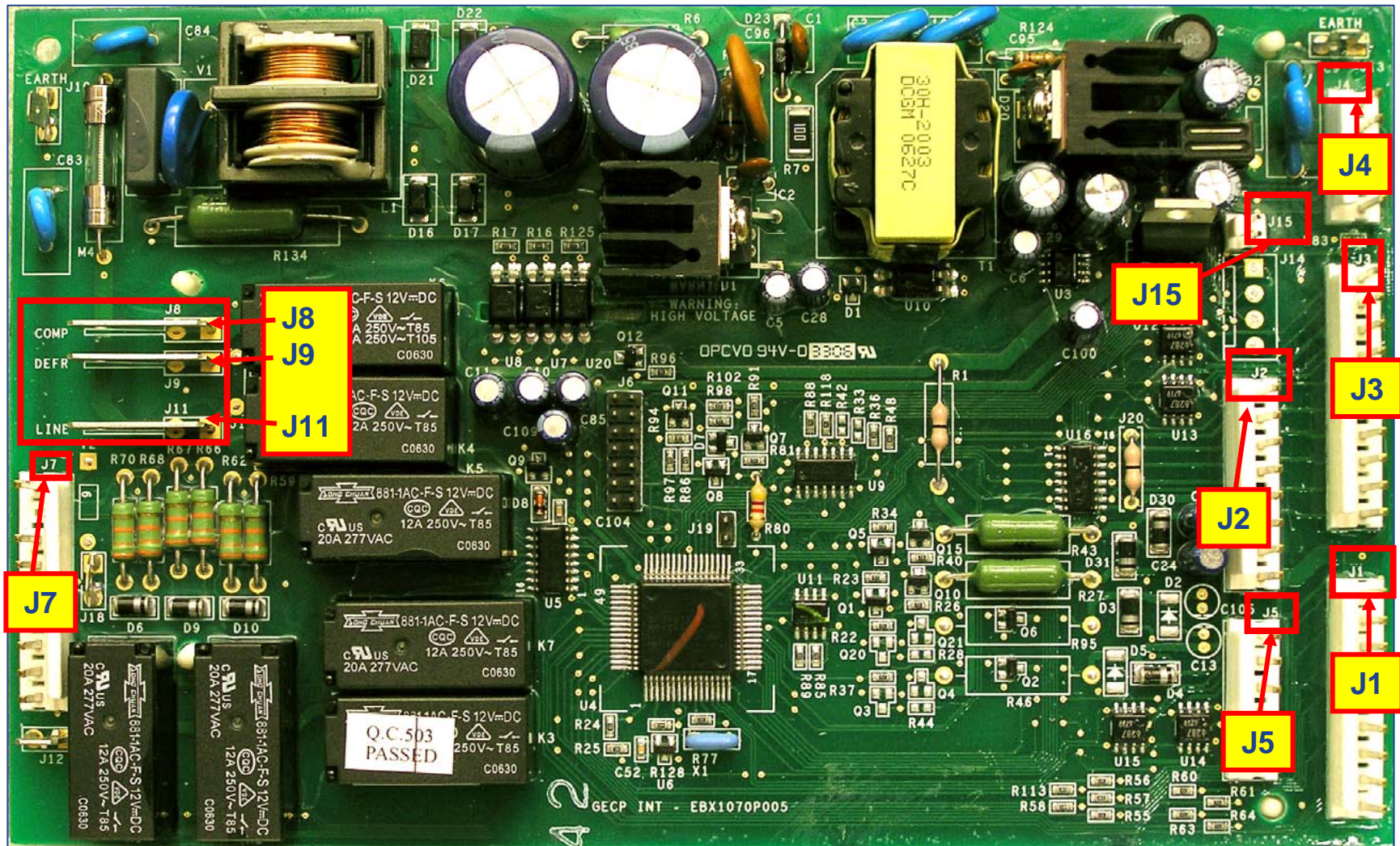

All "J" connectors are labeled on the main board, check the schematic for each model; since there may be some differences depending on the model.

Component problems?

The main board provides power to the components.

If the component is not running, it could be:

- The main board is not supplying power.
- To verify this, measure the output voltage with your volt meter.
- If there's no individual output voltage, the problem is at the board.
- But if you have voltage, verify the connections. A bad connection will prevent the component from receiving power.
- Verify the component itself. If it's receiving power and doesn't run, the component is the problem.

When using the Diagnostics Mode to verify the component's operation:

- Measure output voltage. This is the ultimate confirmation to locate the problem.
- Unless otherwise stated; voltage tests should be done with the load connected.

The diagnostics in this module cover individual DC components and their testing. If none of the components are operating – check the AC input to the board and the DC outputs. A shorted DC component can take down the main board.

Main Electronic Board Testing – Line Voltage Input

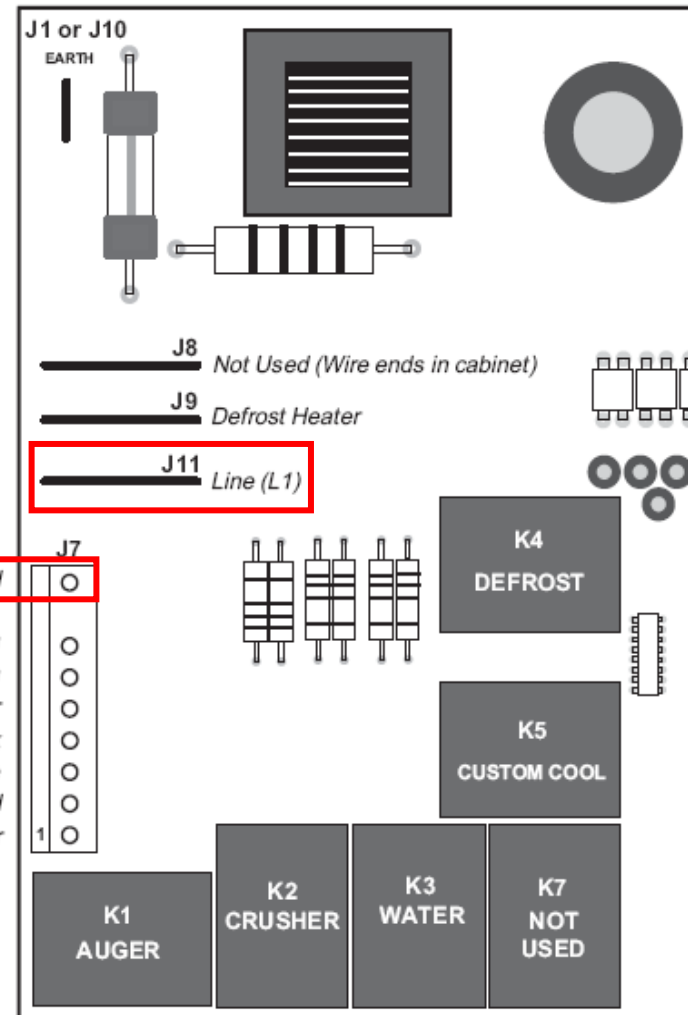
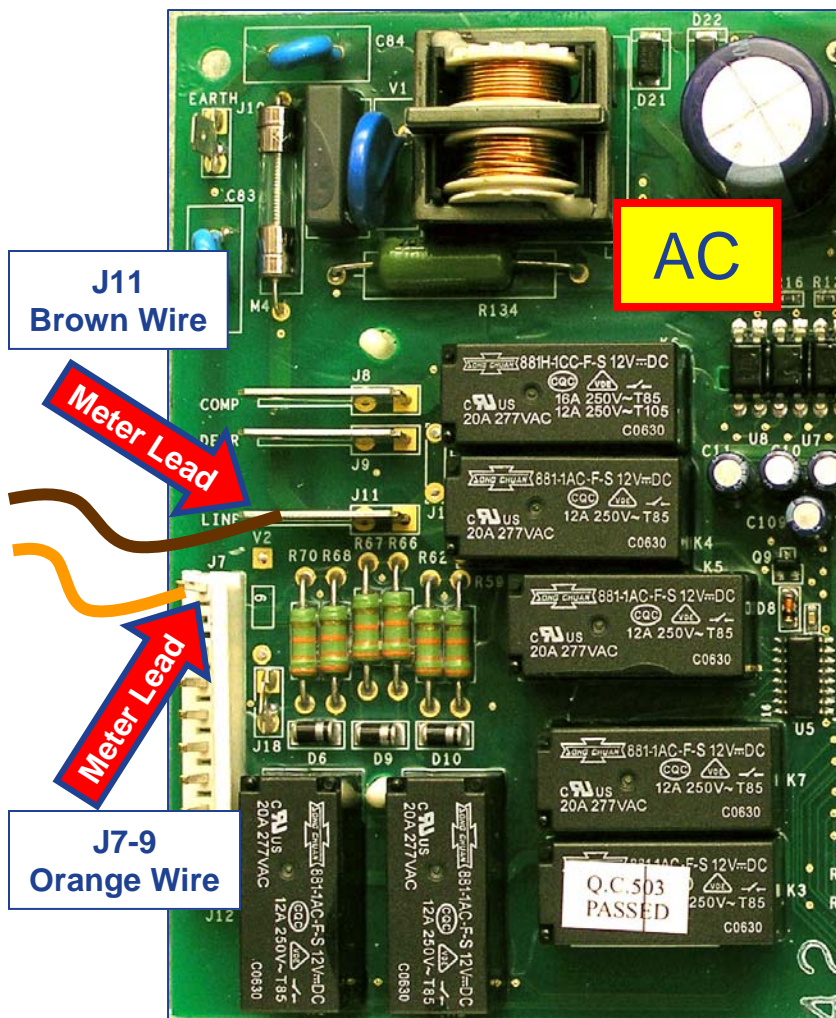

For a dead refrigerator with interior light operation only, check the input voltage to the main board.

To test for 120vac for line voltage to the main board, place your meter leads as shown in the above example.

Main Electronic Board Testing DC Output

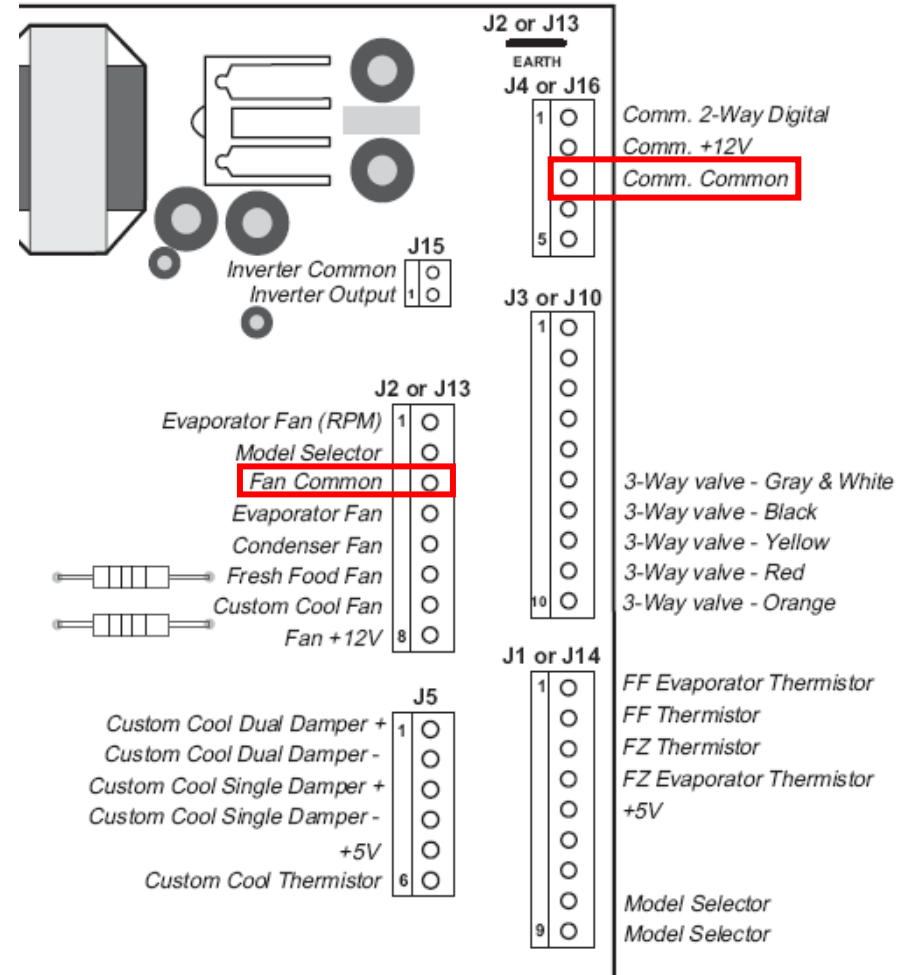
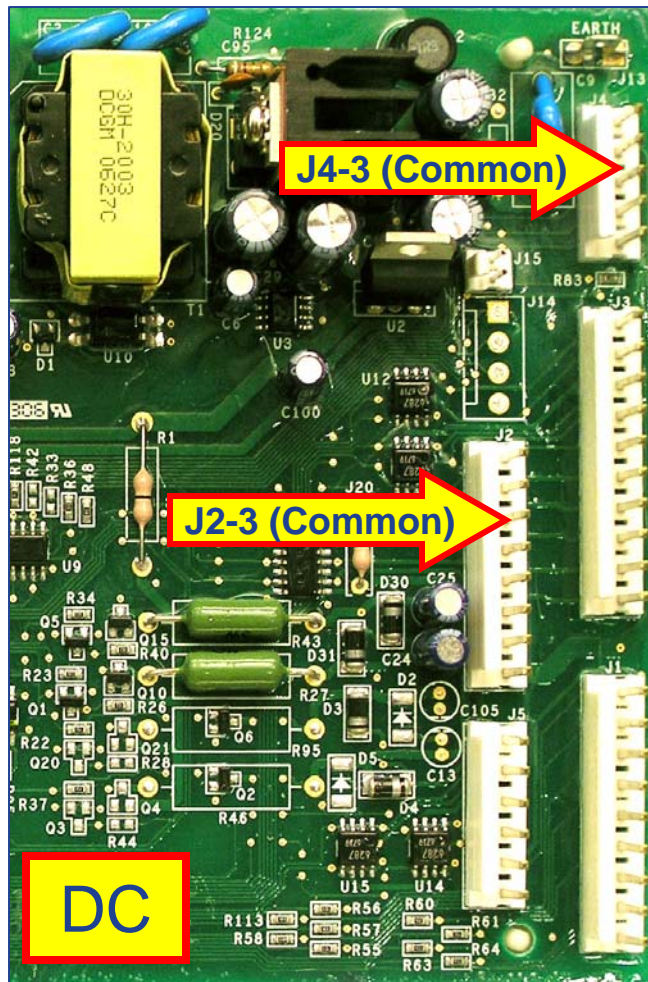

For DC voltage measurement, you will need to read between a DC common connection and the connection for the specific DC component you are checking. DC commons can be found at either J2 pin 3 or J4 pin 3.

Main Electronic Board Testing DC Output

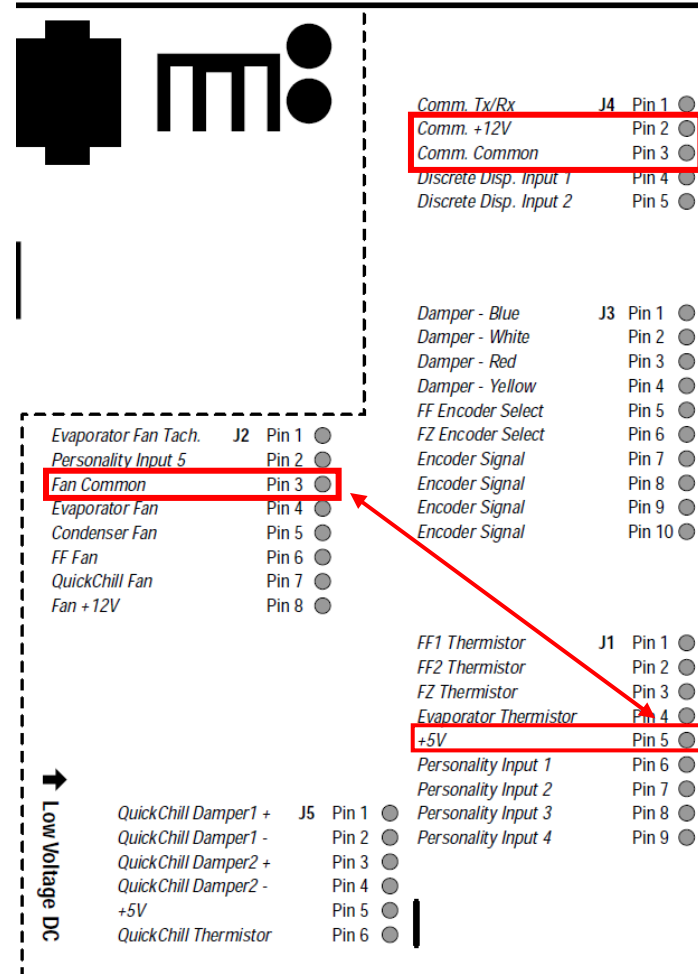
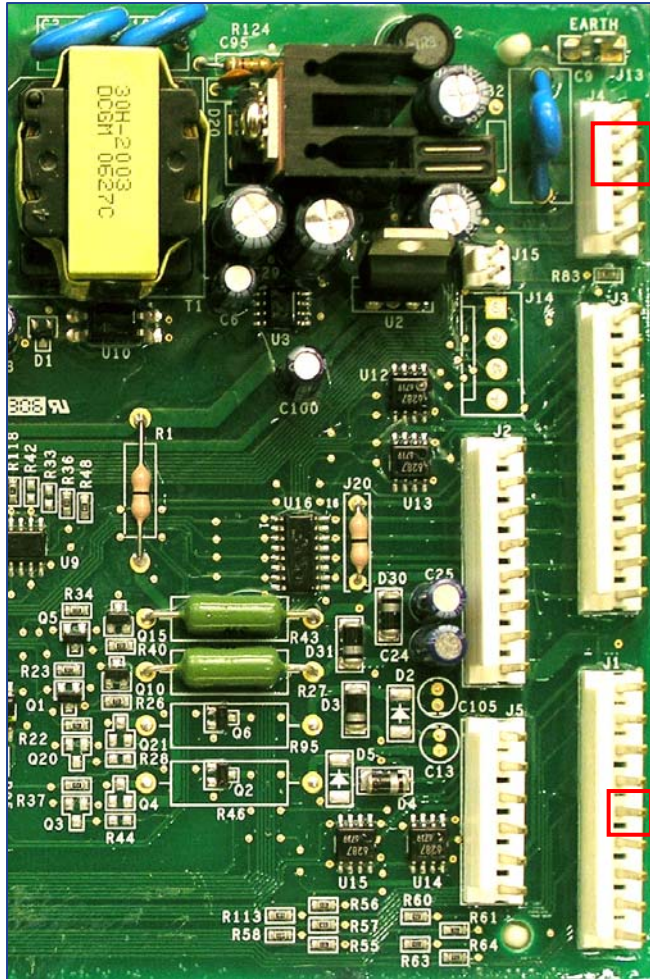

When the refrigerator is connected to line power the main board power supply outputs two critical voltages for operation, 12vdc and 5vdc. To check the DC power supply of the main board; read the 12-13 volts DC from the J4 pins 2 and 3; 5 volts DC can be read from J1 pin 5 to either board common.

Main Electronic Board

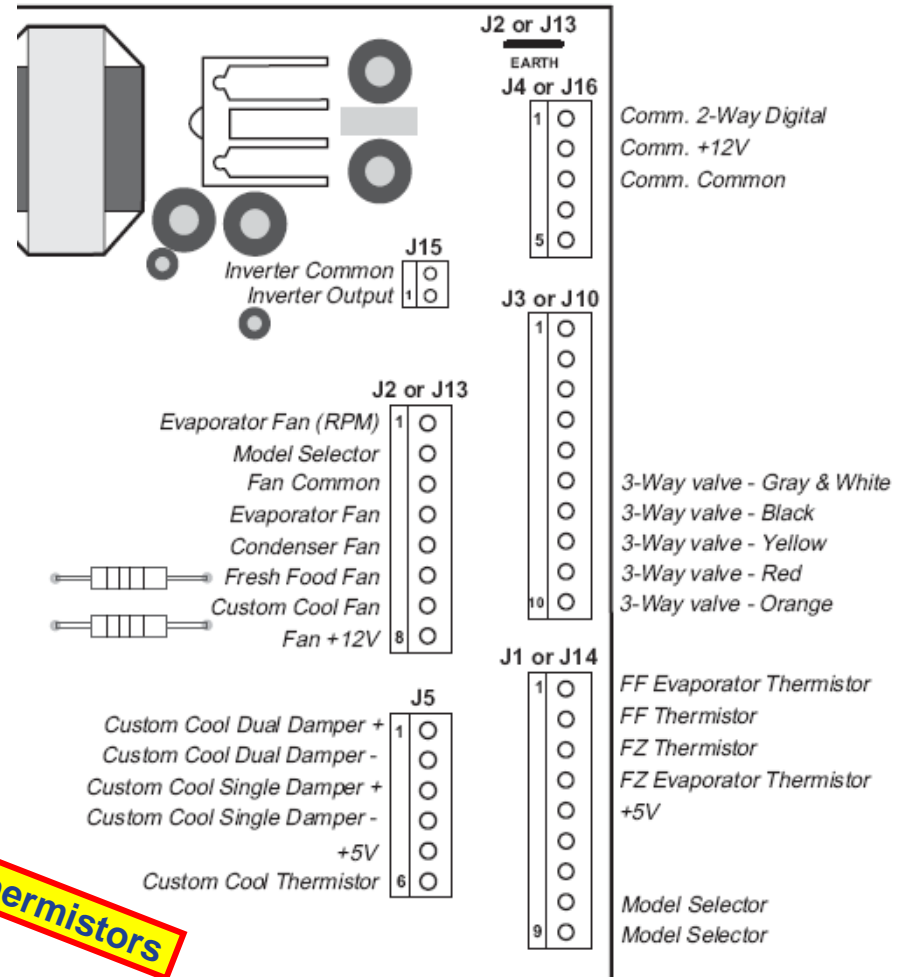
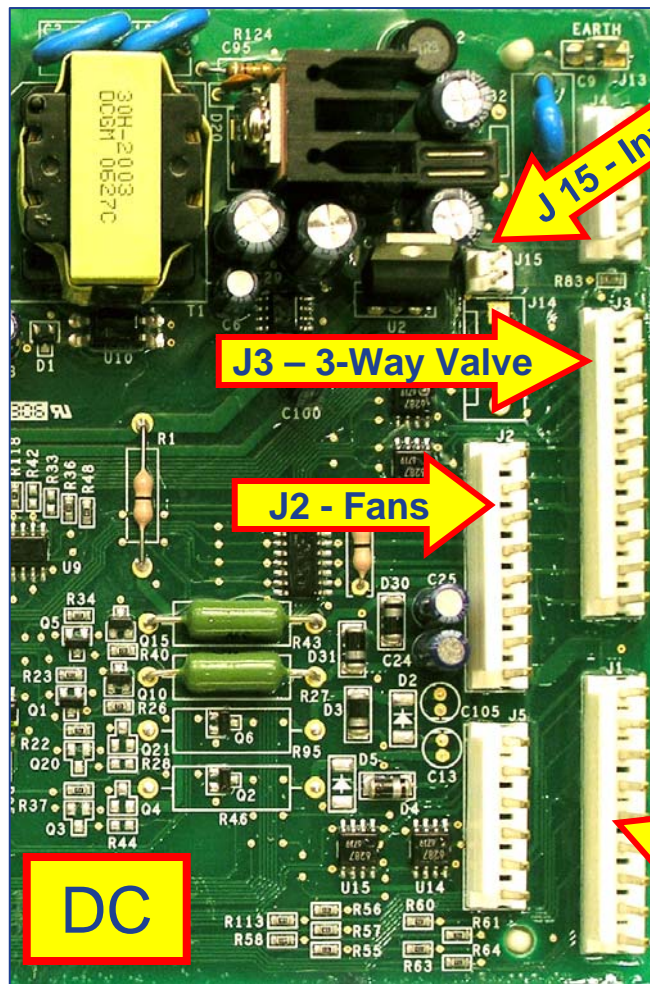

- Each DC component is connected at various plugs on the DC side of the board and operate on different DC voltages.
- J1 for Thermistors, J2 for fans, J3 for the 3-Way Valve, and J15 for the inverter models.
- Remember to measure a DC voltage, you must measure from one of the DC common points: J2 pin 3 or J4 pin 3.

Main Electronic Board J4 Connector

Typically we think of 12vdc circuits consisting of black and red wires. This is not always the case with an electronic refrigerator. Check the diagram of the unit you are working on for the color coding of these wires. This supply voltage also powers the dispenser and temperature control boards. So if you have a control board that is blank, check the 12vdc input to that board. If the voltage is present the board is defective, if not check the wiring connections.

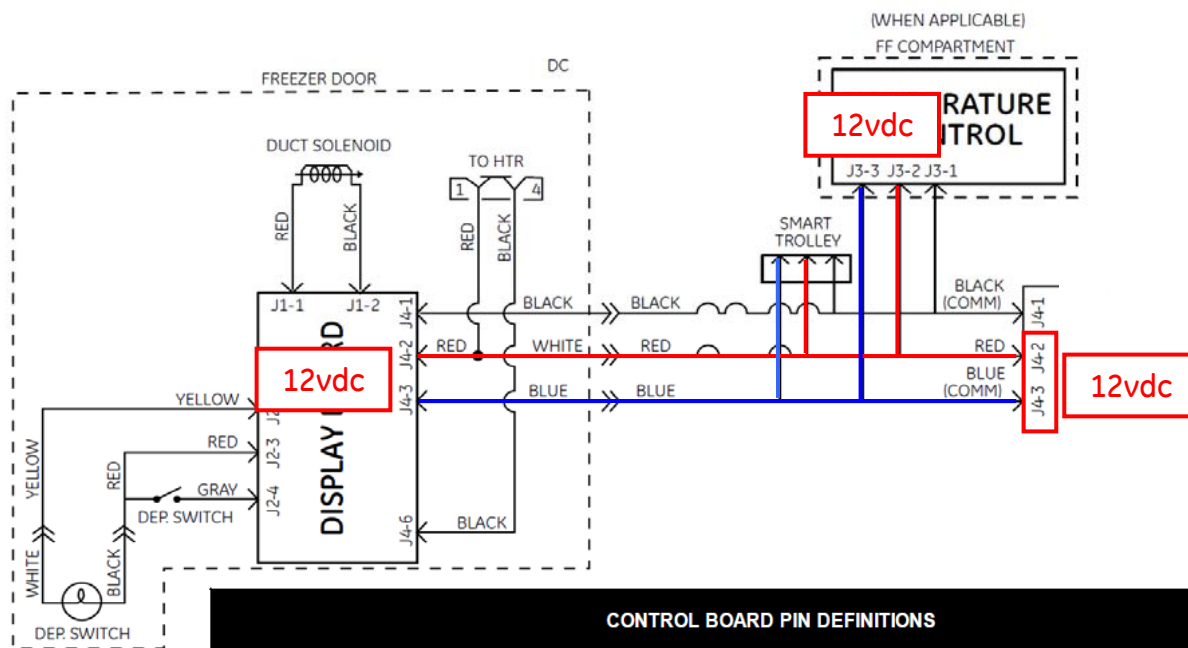

CONTROL BOARD PIN DEFINITIONS				
CONNECTOR	PIN	INPUT	OUTPUT	FUNCTION
J4	1	Digital Communication	Digital Communication	2-way digital communication between main control board and door dispenser display board, temperature control (board), and QuickChill (Custom Cool) temperature control (board).
J4	2		VDC	12 VDC supply.
J4	3		VDC	DC common.



Main Electronic Board J4 Connector

Pin 1 on the J4 connector is used for digital communication between the boards. Typically if this wire is broken or has a poor connection the sub boards will light but not operate components.

You can also check dc voltage from pins 1-2, you should see a -12vdc.

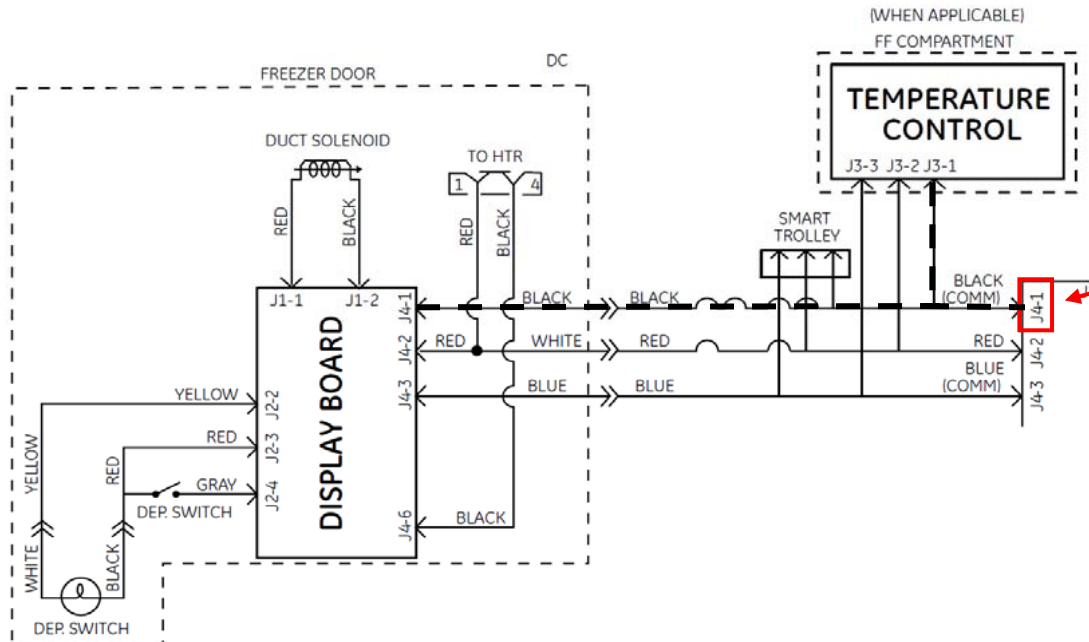

CONTROL BOARD PIN DEFINITIONS				
CONNECTOR	PIN	INPUT	OUTPUT	FUNCTION
J4	1	Digital Communication	Digital Communication	2-way digital communication between main control board and door dispenser display board, temperature control (board), and QuickChill (Custom Cool) temperature control (board).

Main Electronic Board J4 Connector

One common symptom of a communication problem on the J4-1 smart trolley is for the HMI board to flash zeros when trying to change settings. Some models will flash all 8's instead of 0's.

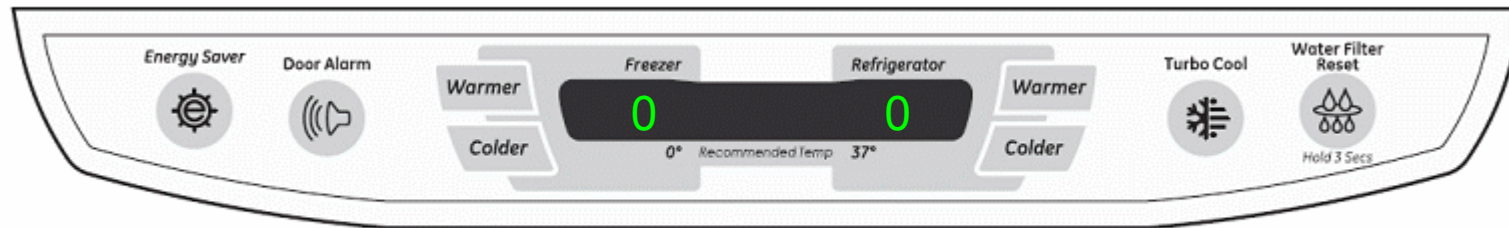

(on some models)

To test the smart trolley communication; you can substitute the test board into the HMI connector. If you receive a Comm error the problem is not with the HMI board – check the smart trolley wiring. You can also plug the test board directly into the main board J4 connector to verify if the main board has a failed communication circuit.



Main Electronic Board J4 Connector

Some models of side by side refrigerators that utilize a tactile switch (button) dispenser board have additional communication wires. These wires control dispenser functions (selections) – if the dispenser is not providing the selected function, check for poor or broken wiring between the main and dispenser boards.

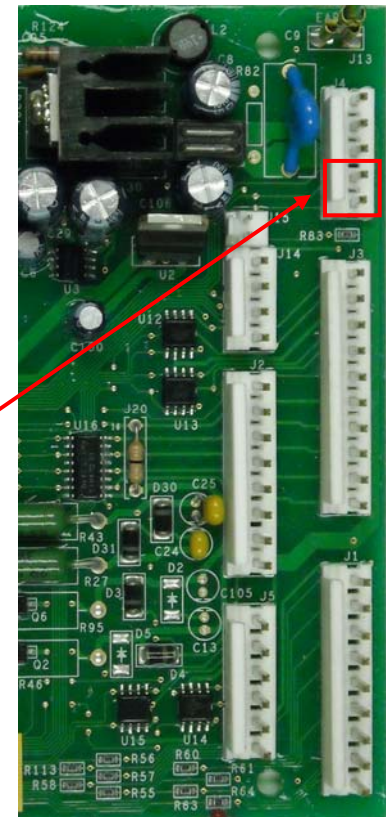
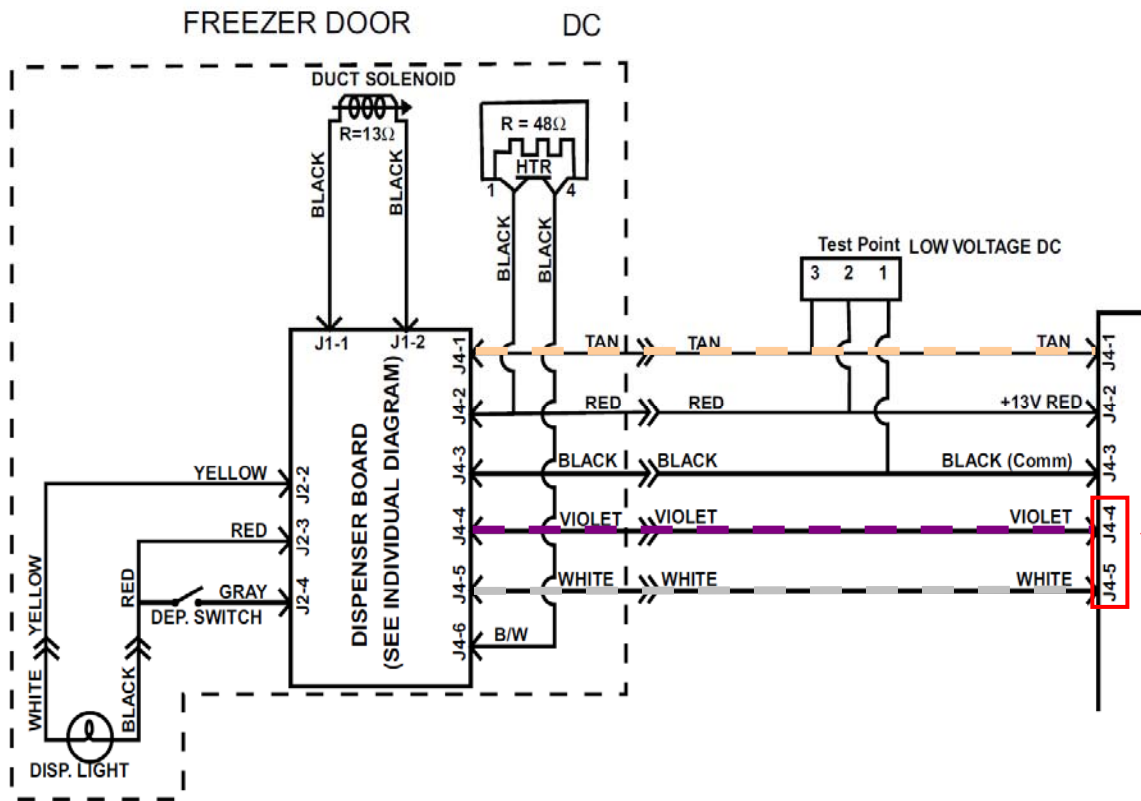

Thermistors



Main Electronic Board Thermistor Connector J1

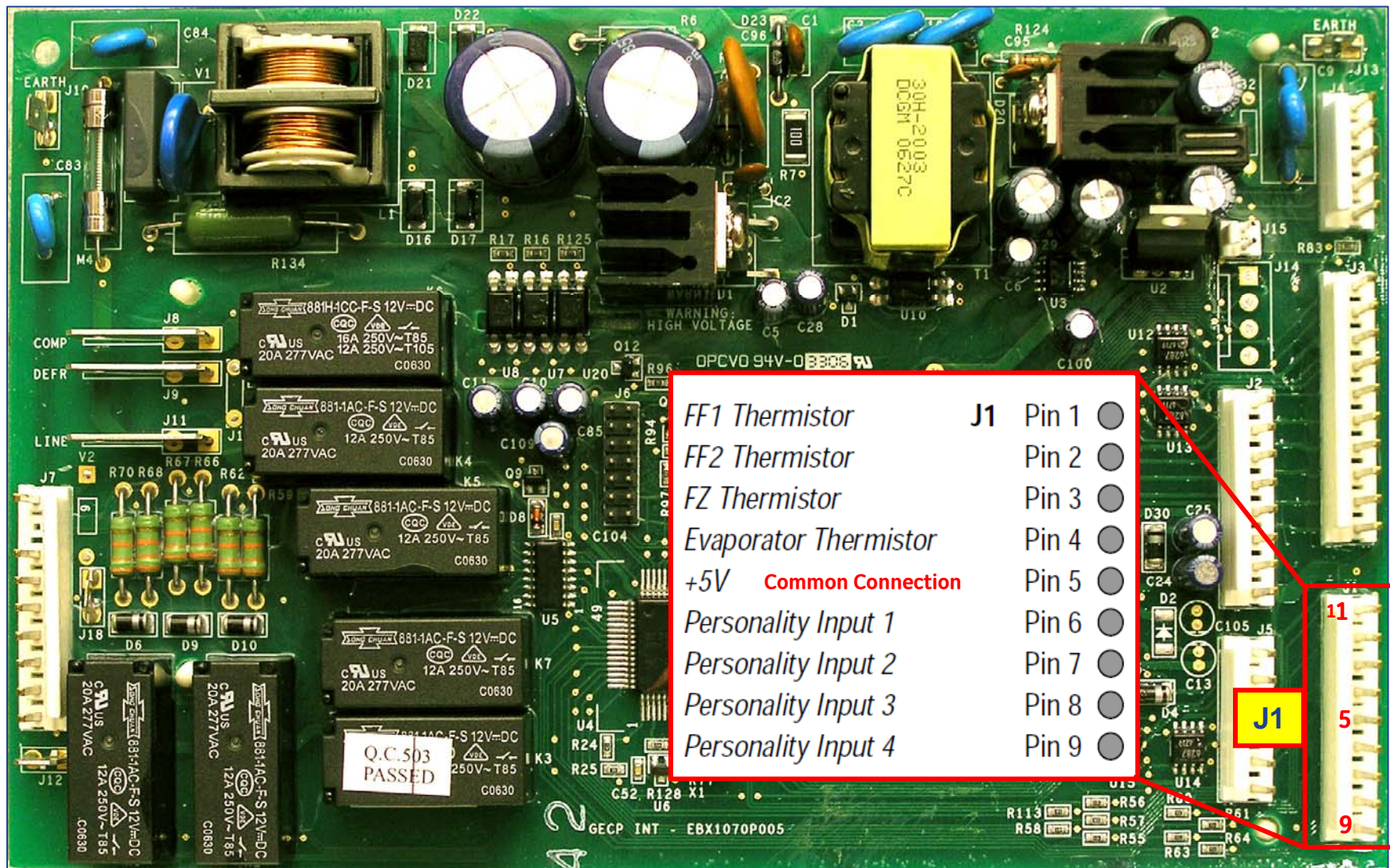

- | | |
|------------------------------|-------------------|
| <i>FF1 Thermistor</i> | J1 Pin 1 ● |
| <i>FF2 Thermistor</i> | Pin 2 ● |
| <i>FZ Thermistor</i> | Pin 3 ● |
| <i>Evaporator Thermistor</i> | Pin 4 ● |
| +5V Common Connection | Pin 5 ● |
| <i>Personality Input 1</i> | Pin 6 ● |
| <i>Personality Input 2</i> | Pin 7 ● |
| <i>Personality Input 3</i> | Pin 8 ● |
| <i>Personality Input 4</i> | Pin 9 ● |

The thermistor connector (J1) is always the 9 pin connector on the edge row connectors regardless of board position.

Thermistor Operation

A Thermistor is a resistance device designed to react to temperatures. The Thermistors GE uses are called NTC (Negative Temperature Coefficient) type; which means as the temperature decreases, the resistance increases. The main board uses a 5vdc signal to read the Thermistors at the J1 connector.

The main board uses input data from the Thermistors; which are located in the fresh food section, freezer section, and mounted to the freezer evaporator. The main board monitors the Thermistors to determine the temperature in these sections of the refrigerator and determines which components to operate and when to operate them based on this data.



Since there is a separate Thermistor to read the temperature in the fresh food section, freezer section, and to determine the temperature of the evaporator to terminate the defrost cycle; some components work along with a specific Thermistor.

Thermistor Operation

The components that will operate under normal conditions when the fresh food Thermistor sends data to the main board for a temperature need are the fresh food fan (available on some models), the damper assembly, evaporator fan, the compressor and the condenser fan.

The components that will operate under normal conditions when the freezer Thermistor sends data to the main board for a temperature need are the freezer fan, damper assembly, the compressor, and the condenser fan.

This illustrates that not all components will operate at the same time. It is possible to find the fresh food fan operating all by itself; the damper open, the fresh food fan, and evaporator fan operating without the compressor; or the compressor and condenser fan operating by themselves. It depends on which section of the refrigerator has a temperature need.

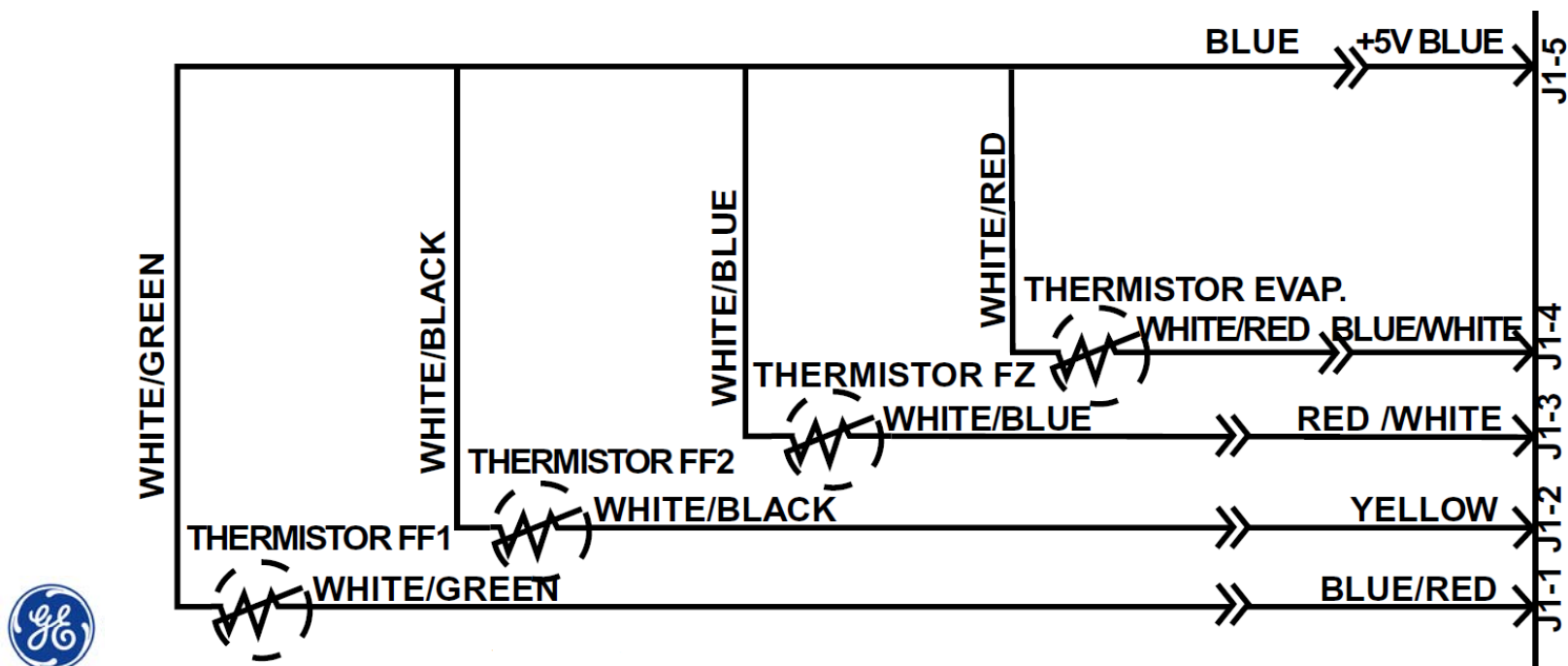

Thermistor Locations

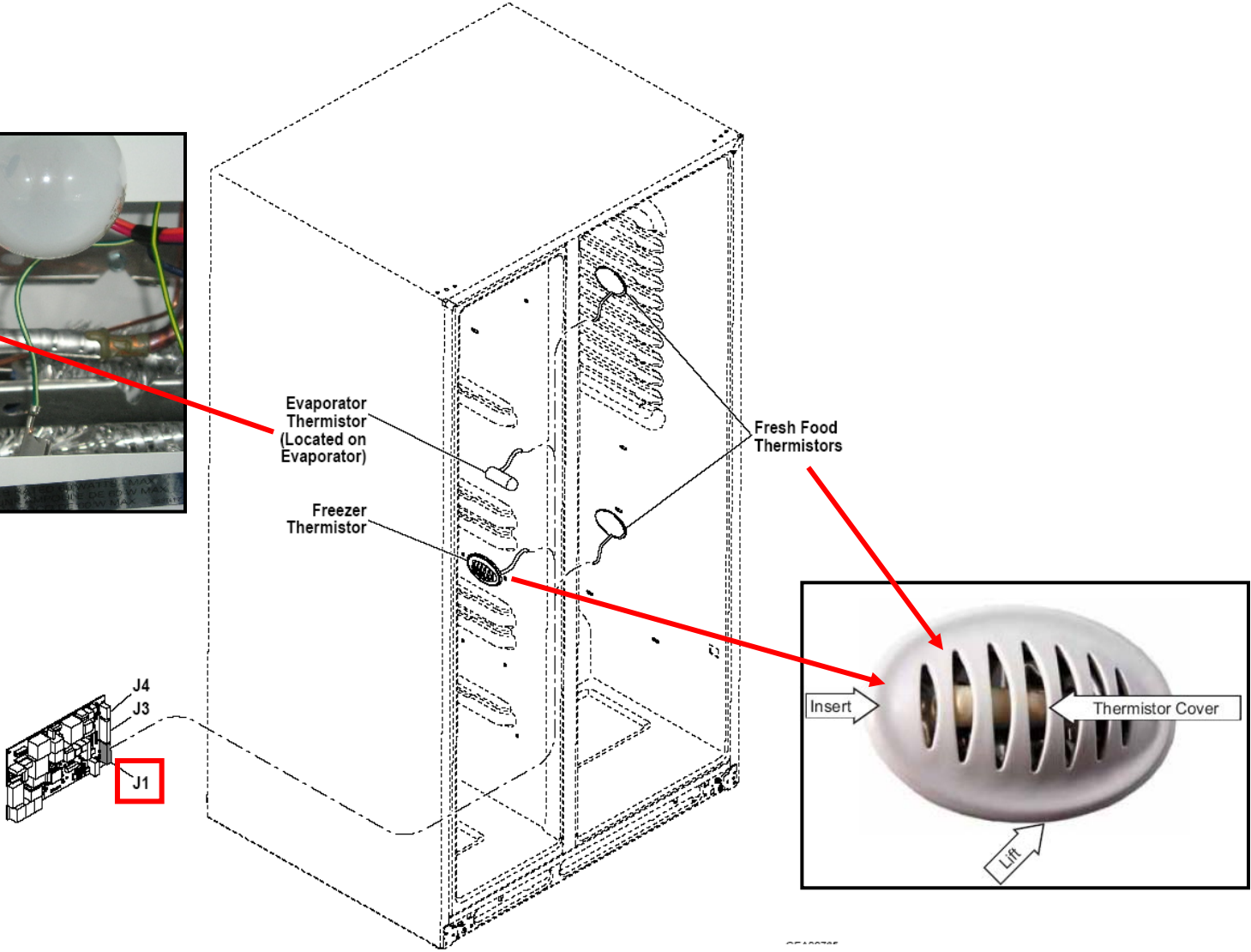
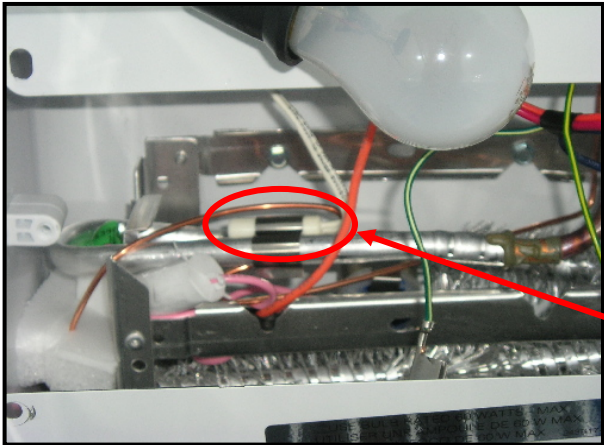

There could be up to 5 Thermistors in a refrigerator, depending on the model.

Main Electronic Board J1 Connector - Thermistors

The J1 connector provides temperature input from the thermistors to control refrigerator run time and cabinet temperatures. The evaporator thermistor is used only for defrost operation (defrost termination and post dwell.) J1 pin 5 sends a common 5vdc to all the thermistors and the main board receives the voltage drop back through pins 1 to 4.

To check the 5vdc output from J1-5 read to the J2-3 or J4-3 board common.

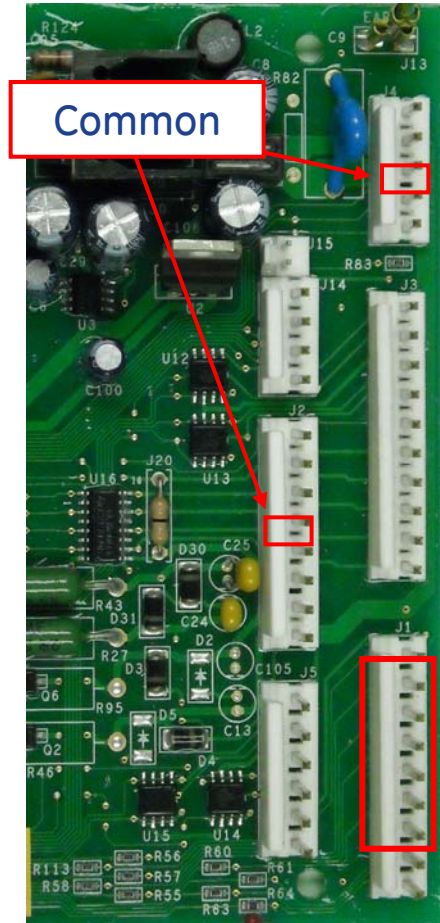
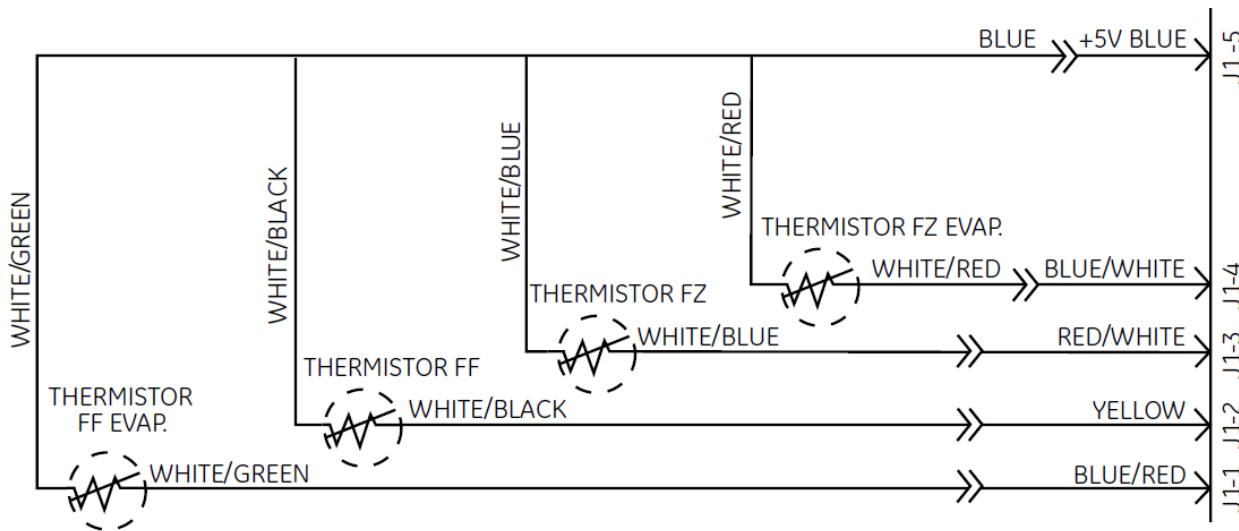

Main Electronic Board J1 Connector - Thermistors

A quick check of the thermistor operation is to read the voltage drop of the thermistors at the J1 connector. Place one meter probe in J1 pin 5 and check each voltage to J1 pins 1 through 4.

Typical voltage drop is between 1 to 4 dc volts. A thermistor voltage drop of 0vdc indicates a shorted thermistor, 5vdc would indicate an open thermistor. Any voltages below 1vdc or above 4vdc could indicate a suspect thermistor, follow up with a direct test of the thermistor.

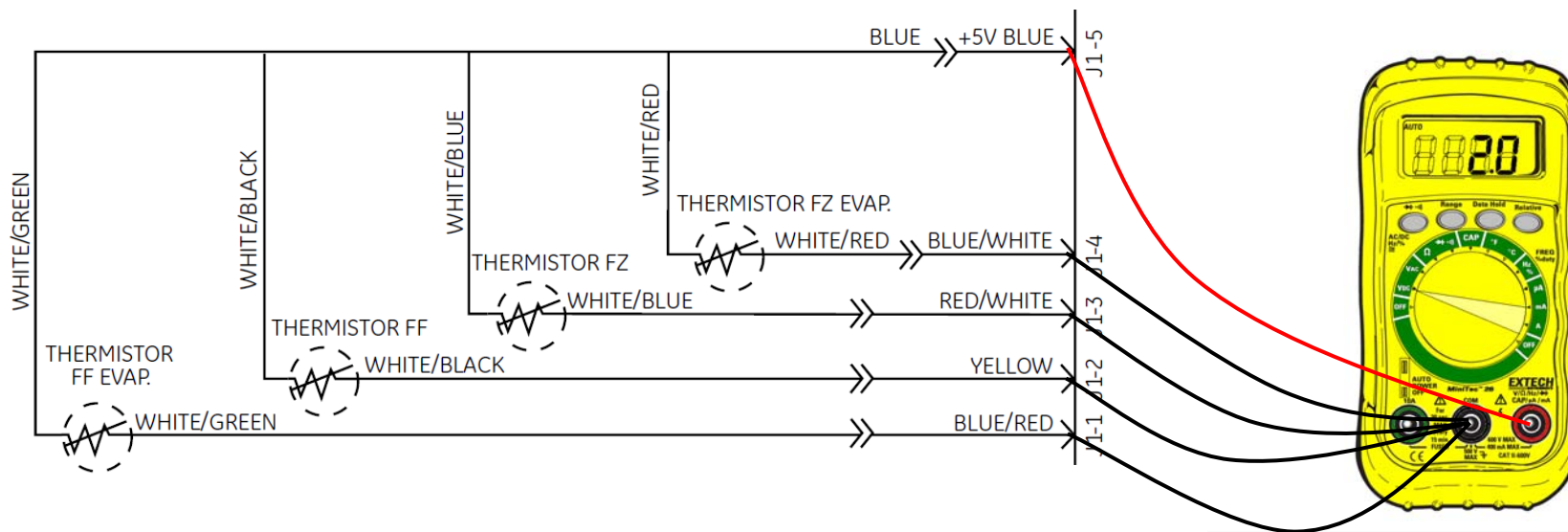

Thermistor Locations

Some variable speed compressor models utilize the FF2 thermistor input for room temperature.

Ambient Thermistor

The ambient thermistor is located under the freezer compartment and connected at J1-2 on the main control board. (See **Component Locator Views**.) It assists the main control board in compensating for room ambient that is higher or lower than 60°F.

For example, in ambient below 60°F, the fresh food temperature control will shut down properly. The cooler room ambient assists in keeping fresh food temperatures at the preset temperature. However, the compressor does not get enough run time to bring the freezer down to 0°F.

At lower room temperatures, the ambient thermistor alters the main control board's calculations for the target temperature. The main control board then runs the compressor at higher speeds to get the freezer, as well as the fresh food, to an acceptable temperature.

If the external thermistor is not functioning, the main control board default will assume the ambient temperature is 90°F and there will be no adjustment to the fresh food or freezer set point.

Check the wiring diagram with the unit for specific thermistor usage

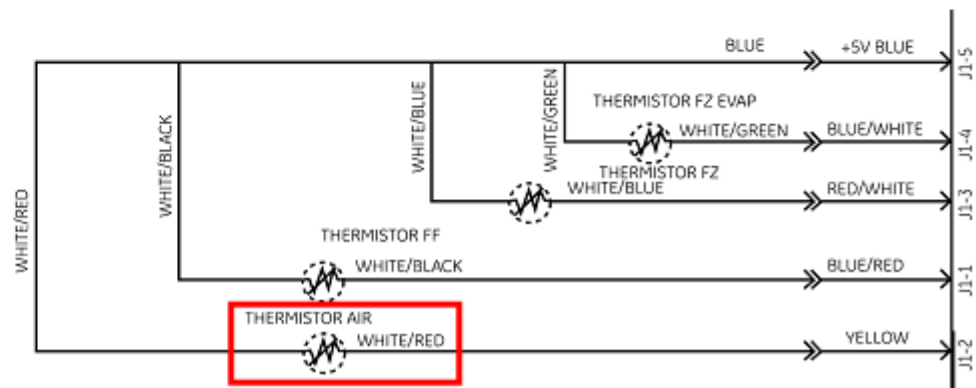

Testing Thermistors

There are a few ways to test the Thermistors in a refrigerator:

You can test the resistance of a Thermistor by checking the temperature at the thermistor (see the chart below), or you can isolate the Thermistor and use a specific temperature.

To test the resistance of any Thermistor using it's normal temperature (for example the freezer air temperature), first disconnect power to the refrigerator and remove the main board access cover on the back of the refrigerator. Then unplug the J1 connector from the main board, we do this to isolate the Thermistor circuit; so the only value that will be displayed on the meter is for that Thermistor. Use the schematic to find the specific Thermistor you want to check. Place the meter leads into the back of the J1 connector (wire side) at pins 3 and 5 to get the resistance value based on the freezer air temperature.



A complete thermistor/temperature chart can be found on the customer.net support site.

Use keywords thermistor and/or chart in the search.

Thermistor Values		
Temperature Degrees (C)	Temperature Degrees (F)	Resistance in Kilo-ohms
-30	-22	88 kΩ
-20	-4	48.4 kΩ
-10	14	27.6 kΩ
0	32	16.3 kΩ
10	50	10 kΩ
20	68	6.2 kΩ
30	86	4 kΩ
40	104	2.6 kΩ



imagination at work

Testing Thermistors

Another way to test a Thermistor is to remove the head of the Thermistor from its mounting and insert it into a cup of crushed ice and a small amount of water. The water will cause the ice to be at its melting point of 32°F. Place the meter leads on the J1 connector as previously described.

The Thermistor will read approximately 16KΩ for 32°F.

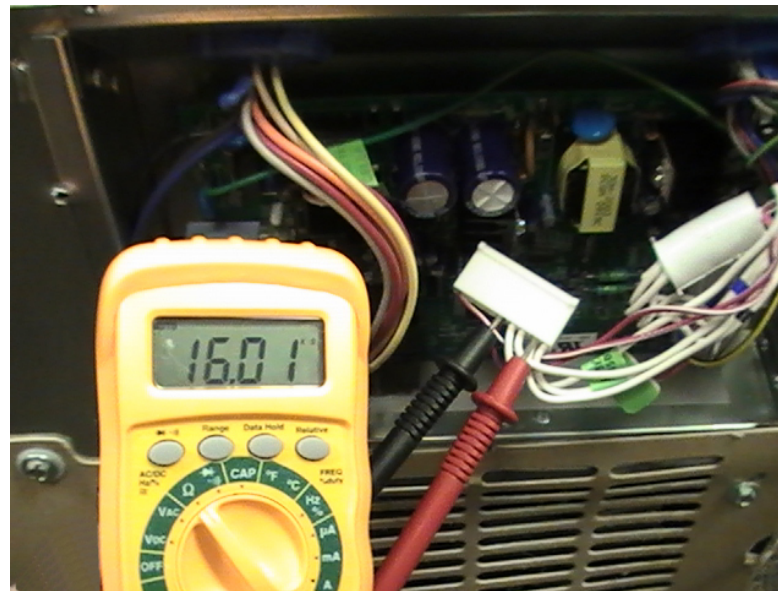

Note: Always test from the wire side of the connector, testing from the board pin side of the connector can cause compression of the pin; creating a poor connection when the connector is installed back on the board.

Testing Thermistors

You can also test the resistance of a Thermistor by checking the thermistor at room temperature.

At room temperature the thermistor should read around 5 to 6 kohms.

Remember, as temperature decreases the thermistor should increase in resistance.



Thermistor Values		
Temperature Degrees (C)	Temperature Degrees (F)	Resistance in Kilo-ohms
-30	-22	88 k Ω
-20	-4	48.4 k Ω
-10	14	27.6 k Ω
0	32	16.3 k Ω
10	50	10 k Ω
20	68	6.2 k Ω
30	86	4 k Ω
40	104	2.6 k Ω

Replacement

Should a thermistor require replacement, use plastic bell connectors (part # WR01X10466). Fill each connector with RTV102 silicone, then splice a new thermistor into the harness as shown in the illustration.

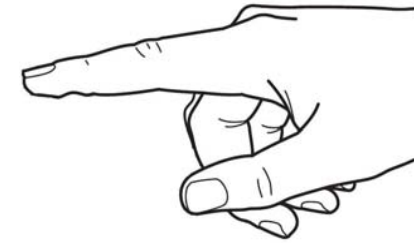
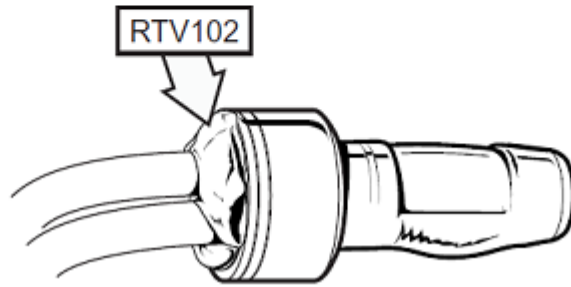

Sensor Shunt

Many models utilize a foil barrier on the back of the thermistor grille called a “shunt.”

This part is required for proper temperature sensing by the thermistor.

If this part is damaged “torn” or not sticking to the back of the thermistor grille, replace the shunt for proper cabinet temperature control.



WR02X10668



Evaporator thermistor location and drip loop

Always reattach the thermistor to its original location to allow for proper temperature sensing.

Never just leave an evaporator thermistor hanging!

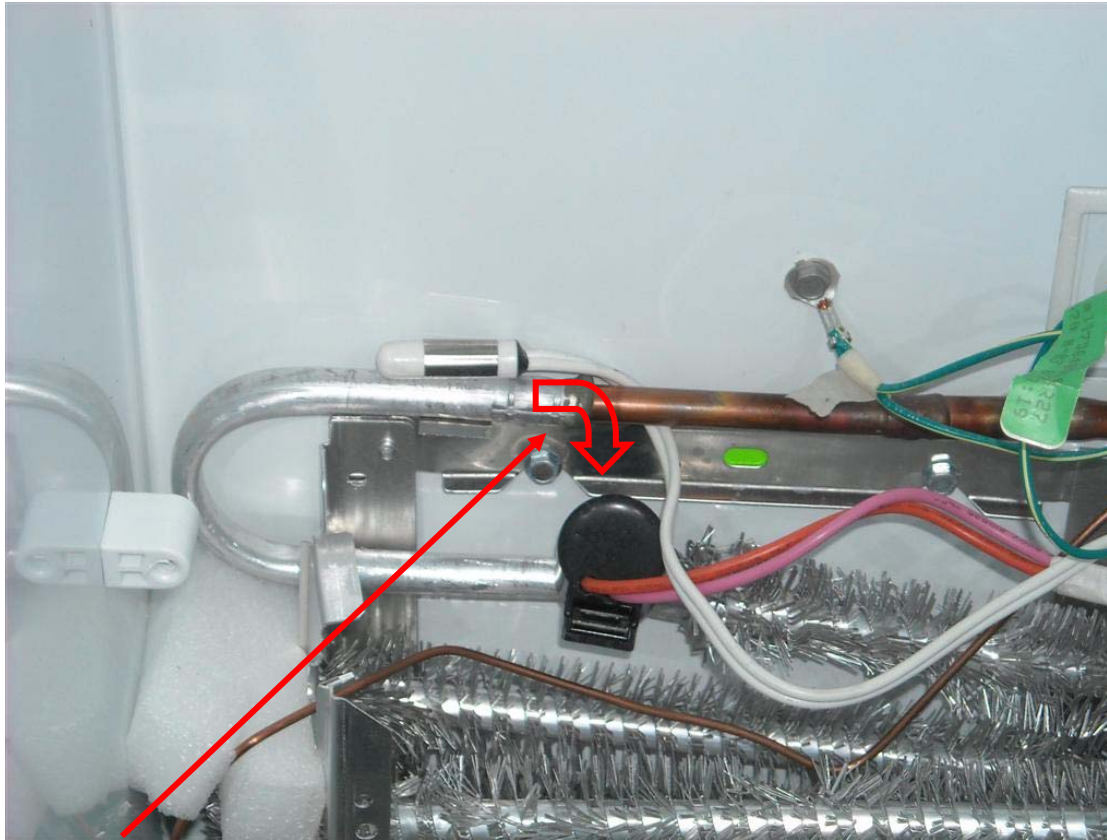

Route the thermistor wiring in a downward angle to create a drip loop. This will minimize the possibility of moisture migrating into the thermistor body over time.

Defrost problems?

Check the FZ Evaporator thermistor:

- If it is biased towards a high temperature, it will terminate the defrost cycle before the heater melts the frost. The thermistor is telling the board not to do defrost, so change it and verify that you get a valid temperature.
- If it is biased towards a low temperature, the defrost will run for a long time, and it will time out, and the system will run defrost too often.
- A new installation is set from the factory to defrost the refrigerator after 8 hours of compressor run time.

Note: On PDS, PFS, GBS and GDS bottom freezer models the evaporator thermistor is mounted to the inlet of the evaporator, check for a short frost pattern if you have cooling or performance issues on these models even though testing shows a low evaporator temperature.

Main Electronic Board J3 Connector - Damper

Most models utilize a damper door to control air flow into the fresh food compartment. The damper door is operated by two stepper motors controlled by the main board. One motor opens the damper door – the other motor closes the damper door. The stepping voltage from the main board to the motors can not be read directly. You must read the damper voltage to the board common.

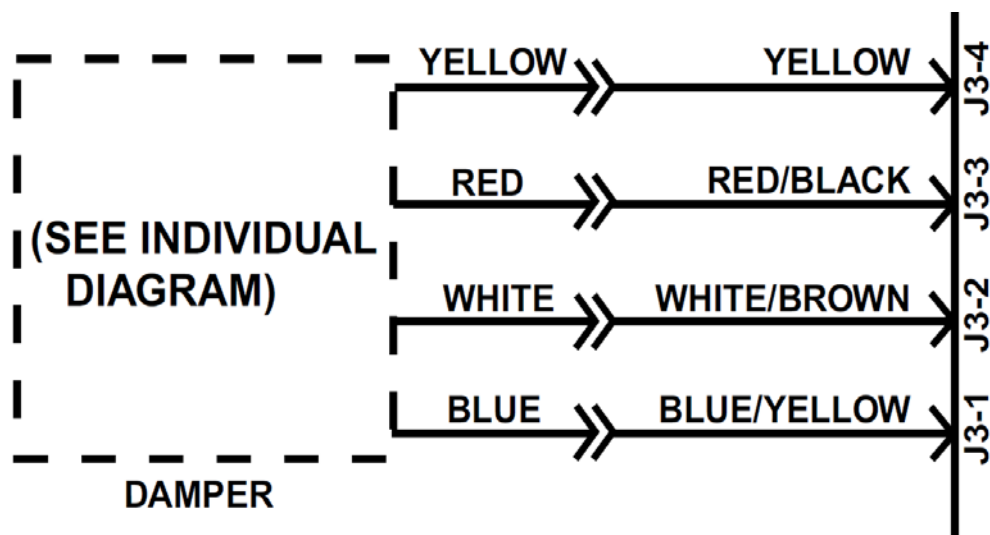

- Pins 1 to 2 are the door opening voltage
- Pins 3-4 are the door closing voltage
- When the damper is not opening or closing, you will see a standing voltage on these pins to board common of approximately 2vdc

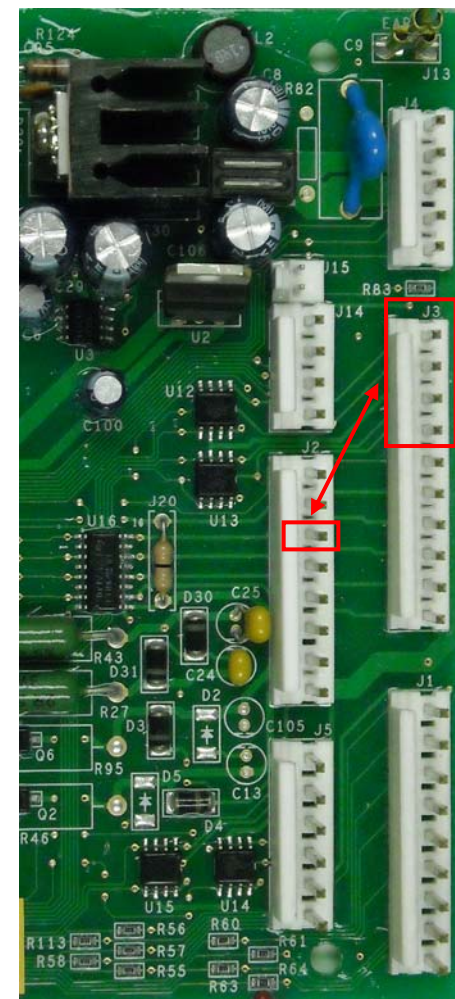

Main Electronic Board J3 Connector - Damper

Diagnostic code 1-0 operates the dampers, or,

Unplug the refrigerator and move the damper door to a partially open position as shown below. When the refrigerator is plugged back in, the main board will drive the door.

If the door fails to open or close – check the four wires of the damper to board ground. You should read 6vdc on all four wires as the damper is opening and closing.

Main Control Board J3 Connector (Low-Voltage DC Side)				
Pin	Wire Color	Component Termination	Input/Output	Pin-to-Pin Voltage Reading
1	Yellow	Damper	Output	J2 pin 3 to J3 pin 1 = 6 VDC
2	Red/Black	Damper	Output	J2 pin 3 to J3 pin 2 = 6 VDC
3	White/Brown	Damper	Output	J2 pin 3 to J3 pin 3 = 6 VDC
4	Blue/Yellow	Damper	Output	J2 pin 3 to J3 pin 4 = 6 VDC

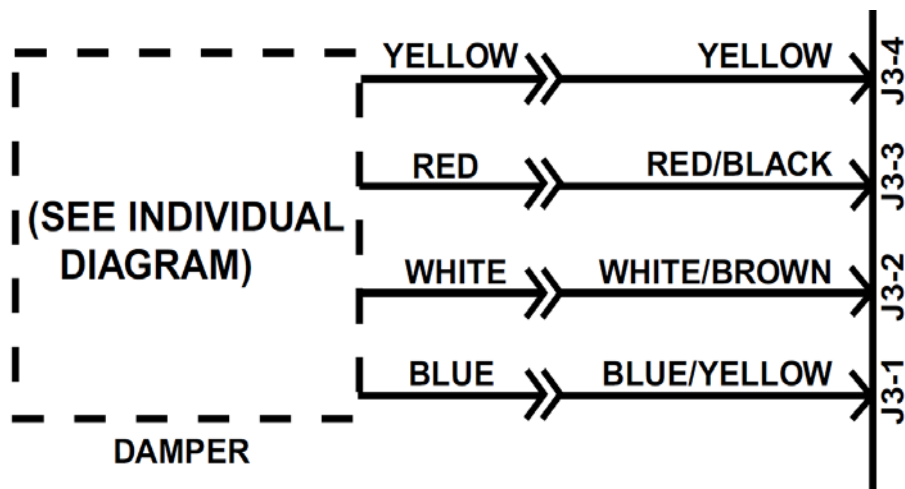

Main Electronic Board J3 Connector - Damper

If the voltage is present and the damper still does not operate – remove the J3 connector and read the resistance of both motors. The typical resistance of the stepper motor is 380-420 ohms. If your meter is not auto ranging, set it on the 2k scale for testing resistance.

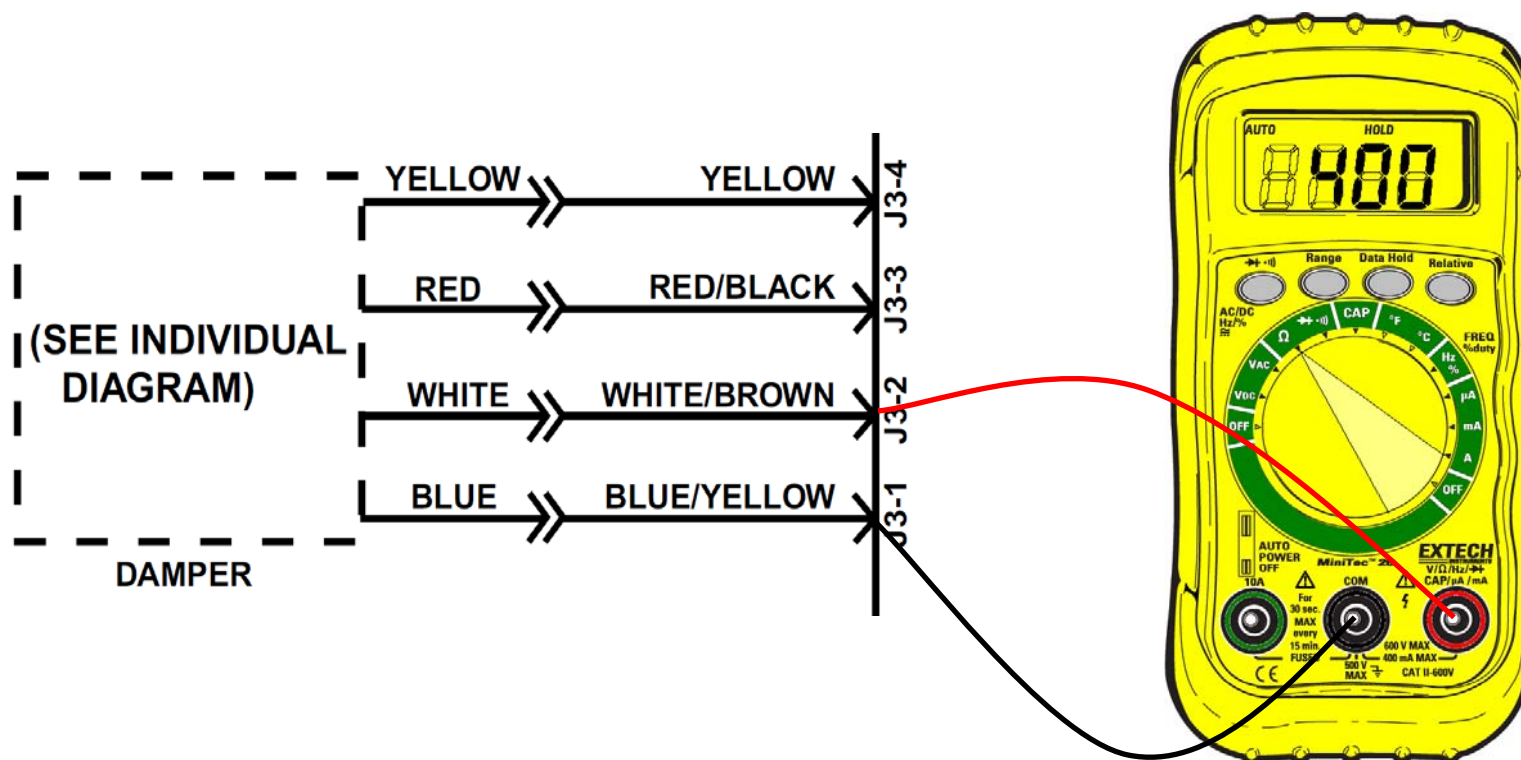

If you read an open circuit check the damper directly. If you suspect the problem may be in the wiring or a connection, jumper the wires at the damper plug. Test for full continuity at the same wiring connections as before. If the voltage and resistance are ok replace the damper.

Main Electronic Board J3 Connector - Encoder

Some model steel liner side by sides use knob controls (Encoder) for temperature setting. These knobs connect to a small circuit board which utilizes diodes to communicate the settings to the main board.

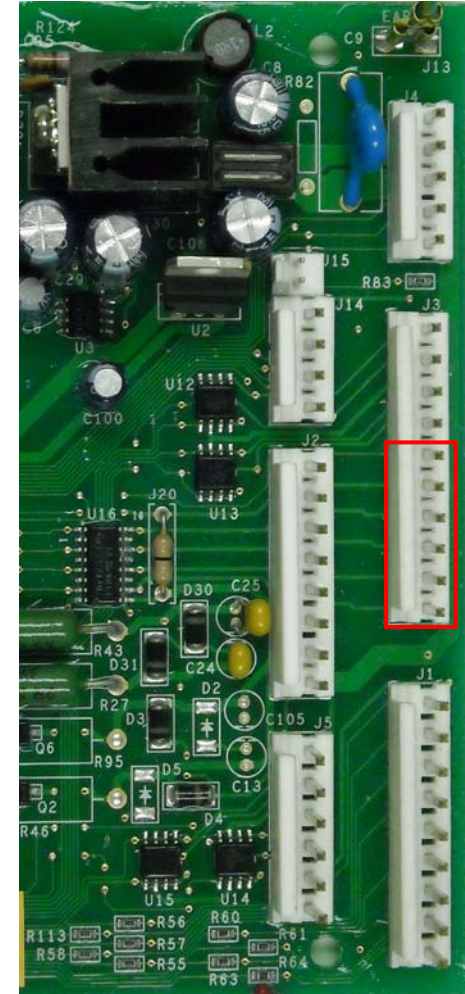
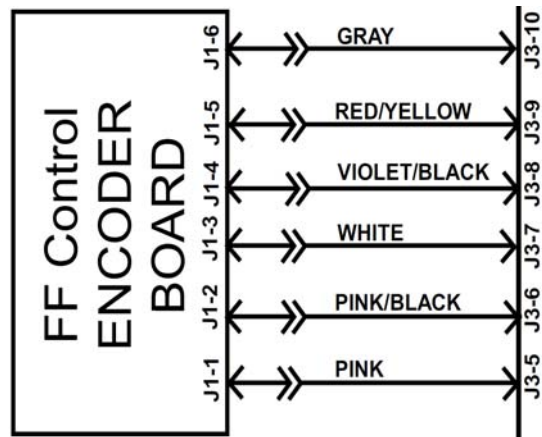
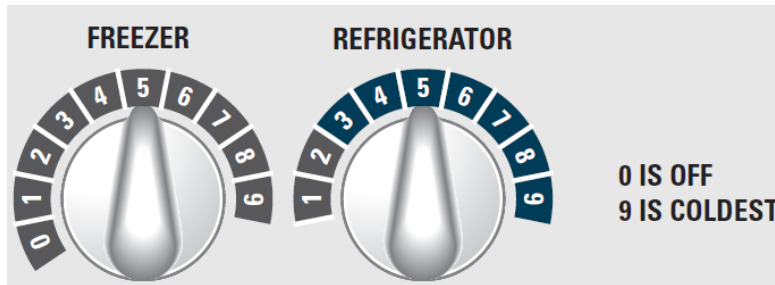

Main Electronic Board J3 Connector - Encoder

If you suspect an Encoder board has the refrigerator shut down, unplug the refrigerator disconnect the J3 connector from the main board. When power is reapplied the refrigerator will turn on at a default setting of 5-5. If the refrigerator starts, follow up with a diode test.

If the refrigerator has had the Encoder board replaced recently and the cabinet temperatures are incorrect, the Encoder board may have been installed upside down. The Encoder board does have markings on the front of the board indicating which side each knob controls.

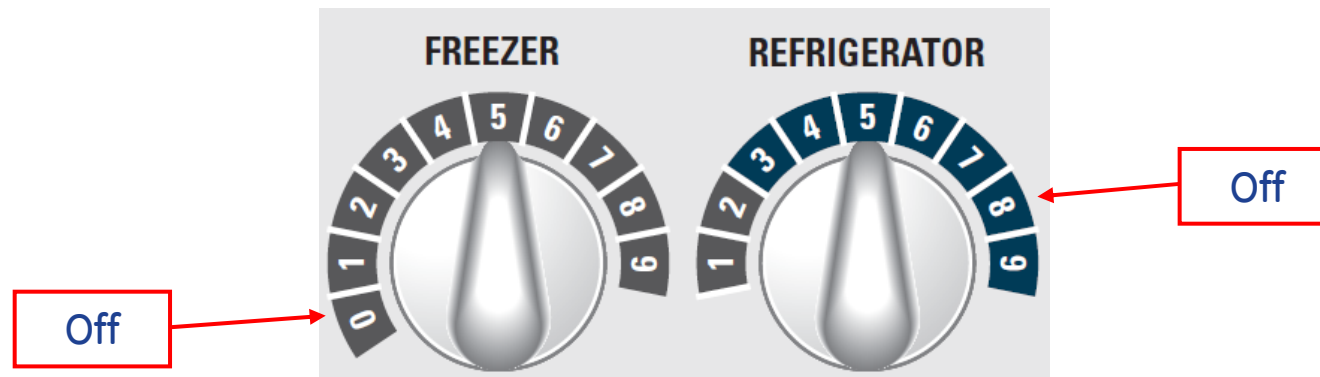

Quick tip:

With the encoder mounted upside down in the housing, the refrigerator control will be in the freezer position and the freezer control in the fresh food position. This causes temperature control problems in both sections. When you turn the fresh food control from 9 to 8, the refrigerator turns off because you are actually turning the freezer control to the 0 position, which is off.

Main Electronic Board J3 Connector - Encoder

Since the Encoder board uses diodes to communicate the settings to the main board you can also test it using the diode check function of your multi-meter. The fresh food control uses pin 5 as common and the freezer control uses pin 6. If any of the tests fail by this chart the Encoder has failed. "Open" in this test means no voltage reading on your meter.

Encoder table for SxS metal liner units. **Do not use for Top Mount Encoder units.**

Use a multimeter to check. Set meter to Diode test position. Positive must be on pins 5 or 6 of J3. Negative must be on pins 7 - 10 of J3.

DV = Diode Voltage. This value should be between 0.45V and 0.75V

Full Truth Table										
FZ knob setting	FF knob setting		FZ pin 6-7	FZ pin 6-8	FZ pin 6-9	FZ pin 6-10	FF pin 5-7	FF pin 5-8	FF pin 5-9	FF pin 5-10
1	1		DV	DV	open	open	DV	DV	open	open
5	5		DV	open	DV	open	DV	open	DV	open
9	9		DV	DV	DV	DV	DV	DV	DV	DV

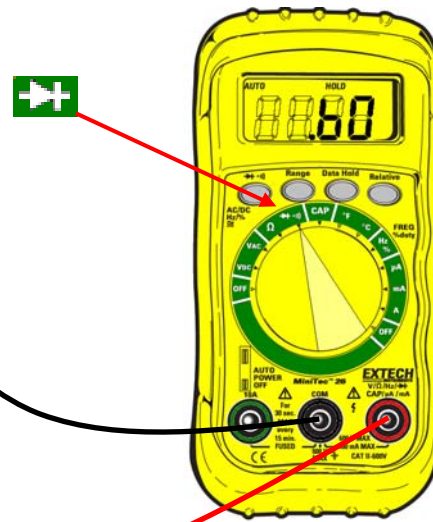
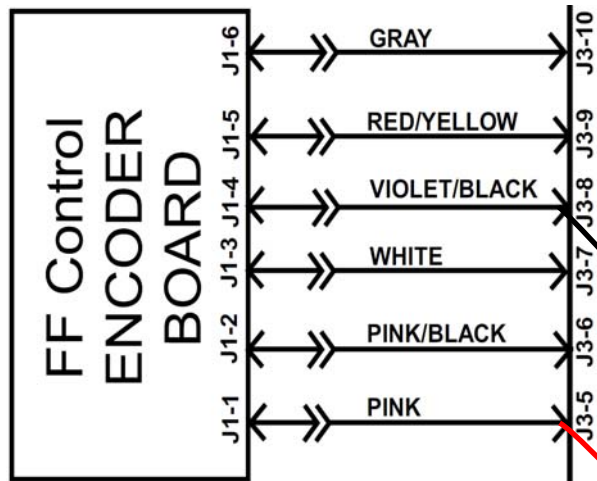

FF Pin 5-8

1 - Will show DV voltage
 5 - Will show open
 9 - Will show DV voltage

The voltage in this test is generated by the meter battery, not the product.

Main Electronic Board J1 Connector – Personality Jumpers

If a unit has been previously serviced and the Dispenser or HMI boards are missing functions, locking up or have strange symptoms – check to make sure the correct part numbers were installed.

There are multiple combinations of main boards and dispenser boards and a mismatch of part numbers can produce unpredictable results. The model jumpers on the J1 connector provides information to the main board on which functions/features will operate on a specific unit.

The model ID jumpers should never be changed or modified. In this case you can see this unit is jumped for a 25 cubic foot cabinet. If a tech replaces the main board and does not follow the instructions for cutting the FF2 wire properly; and cuts the model jumper – the board now thinks it is a 20 cubic foot model.

The cabinet temperatures will be affected.

Note: 20 cubic foot steel liner side by sides do have a loose ID wire by the J1 connector, this wire is only connected for 22 cubic foot models.

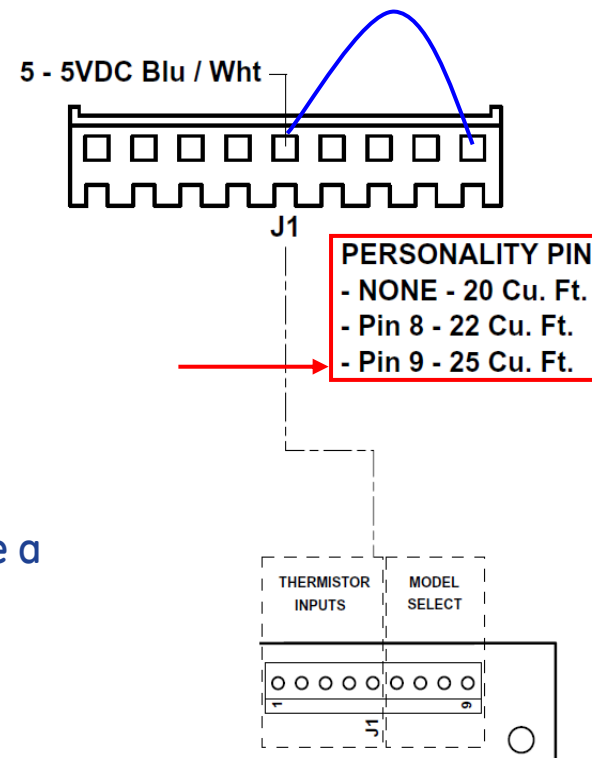

Main Electronic Board J2 Connector - Fans

The J2 connector controls most all refrigerator fan operation. Most of these fans are operated by a DC pulsed voltage and can be variable speed. Check the wiring diagram for fan configuration.

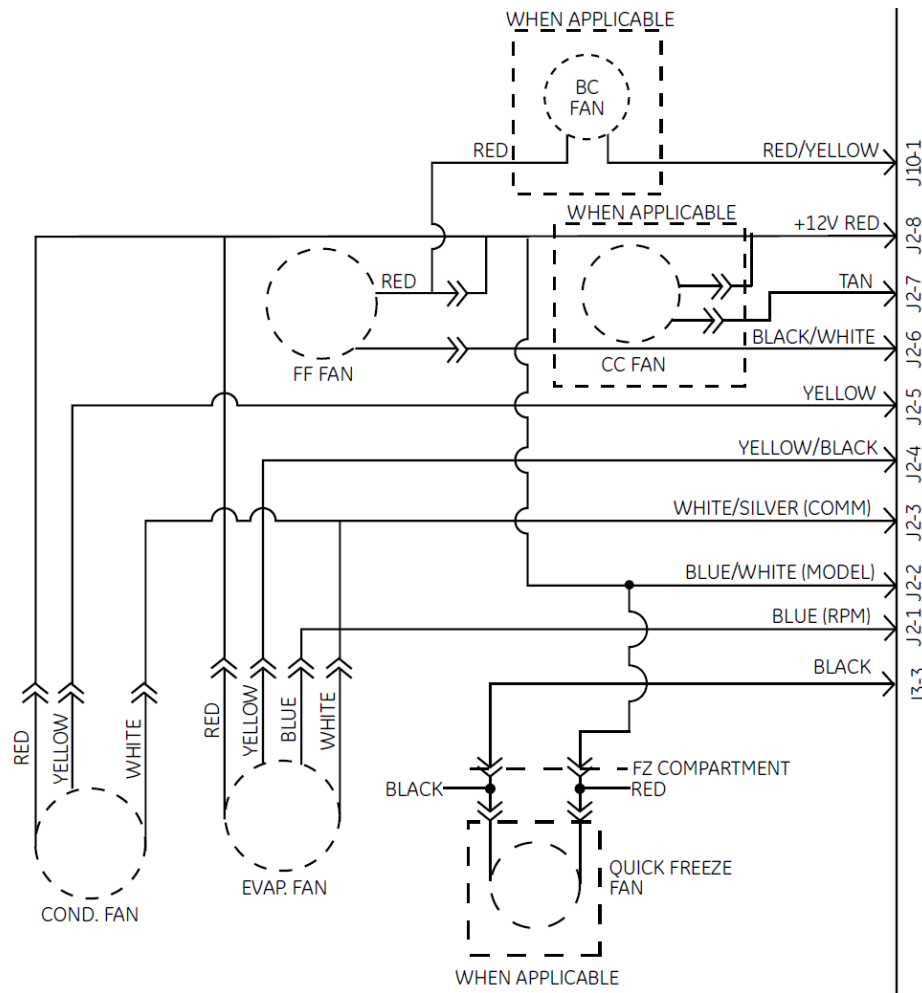

Note: Some electronic refrigerators use an AC condenser fan motor

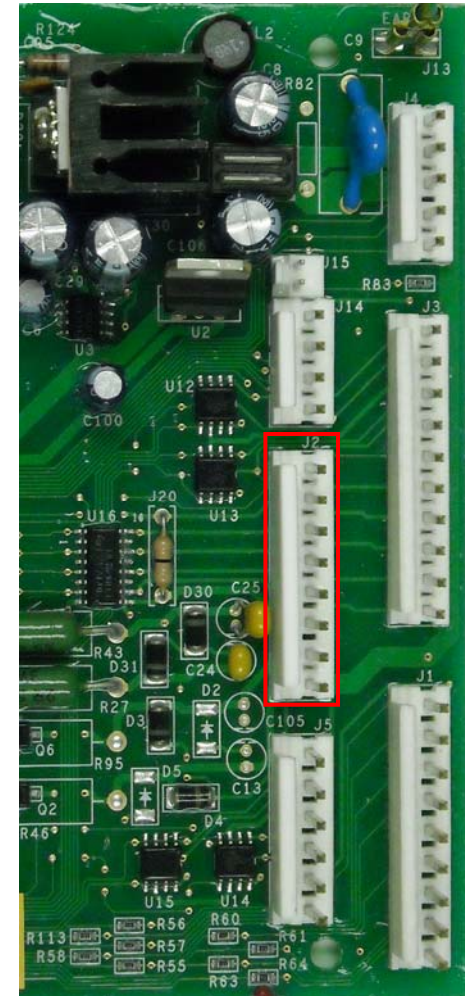

Electronic Refrigerator Fans

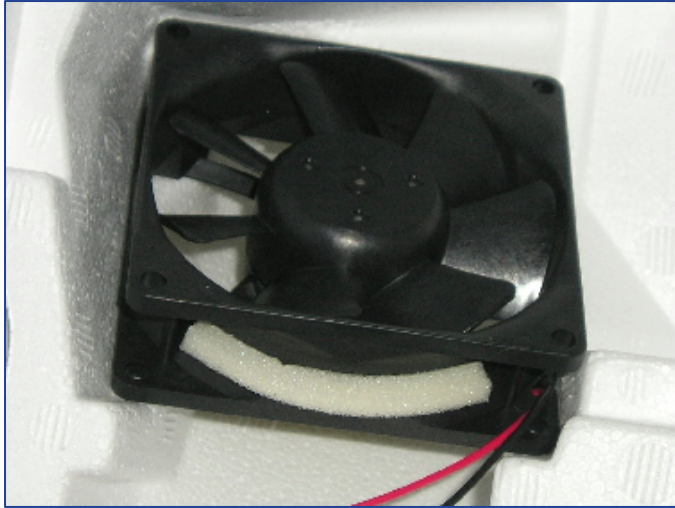

Fresh Food Fan
Not available on all models.



Freezer Fan

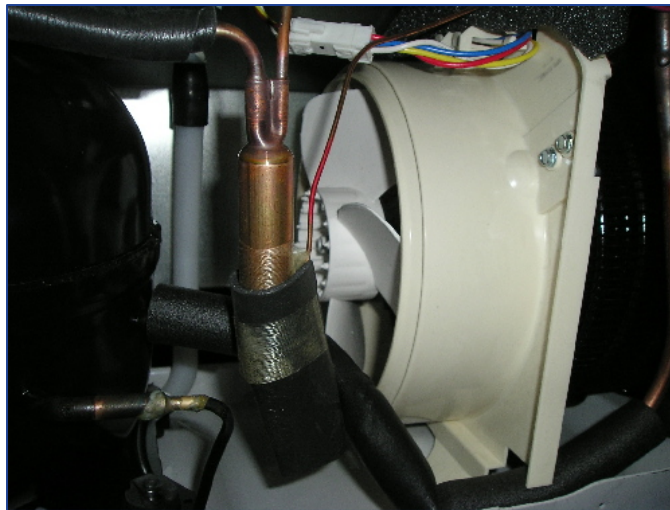

Condenser Fan

Main Electronic Board J2 Connector - Fans

The main board will sense a temperature need through the Thermistors, as discussed previously. Then the main board will send a PWM signal to the specific fan motor that needs to operate.

Most fan motors are wired to the main board through the J2 connector. Each fan has a power supply circuit and a signal circuit.



Wire colors can vary, check the schematic with the unit.

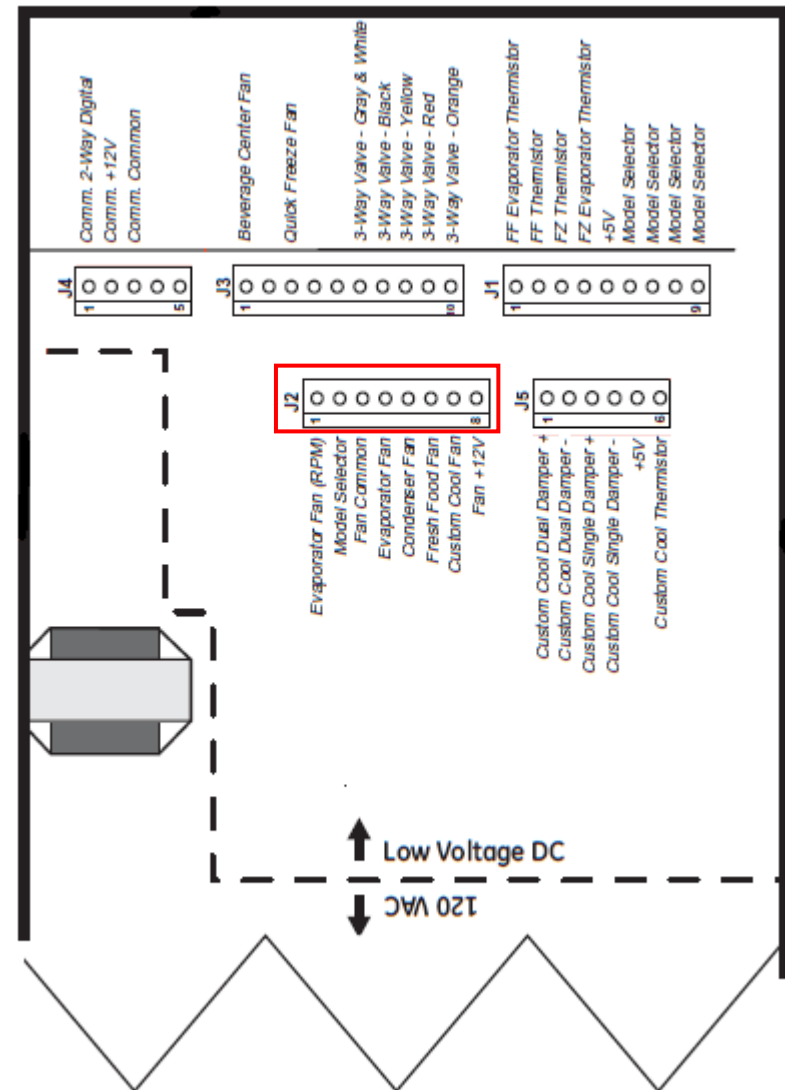

Fan Operation

Fans in the electronic refrigerators are DC fans and they operate on what we call Pulse Width Modulation (PWM). Each fan is pulsed with voltage (frequency) to operate that specific fan motor and can operate at different speeds depending on the PWM signal supplied to that fan motor.

The pulses can not be measured with a voltmeter because the pulse has an ON point and an OFF point (see the chart below). A voltmeter will average the ON and OFF points to read what we call “effective voltage” and that is what the chart below shows.

The slower the fan speed, the longer the OFF point will be, the faster the fan speed the longer the ON point will be; and for the fastest speed the PWM is constant.

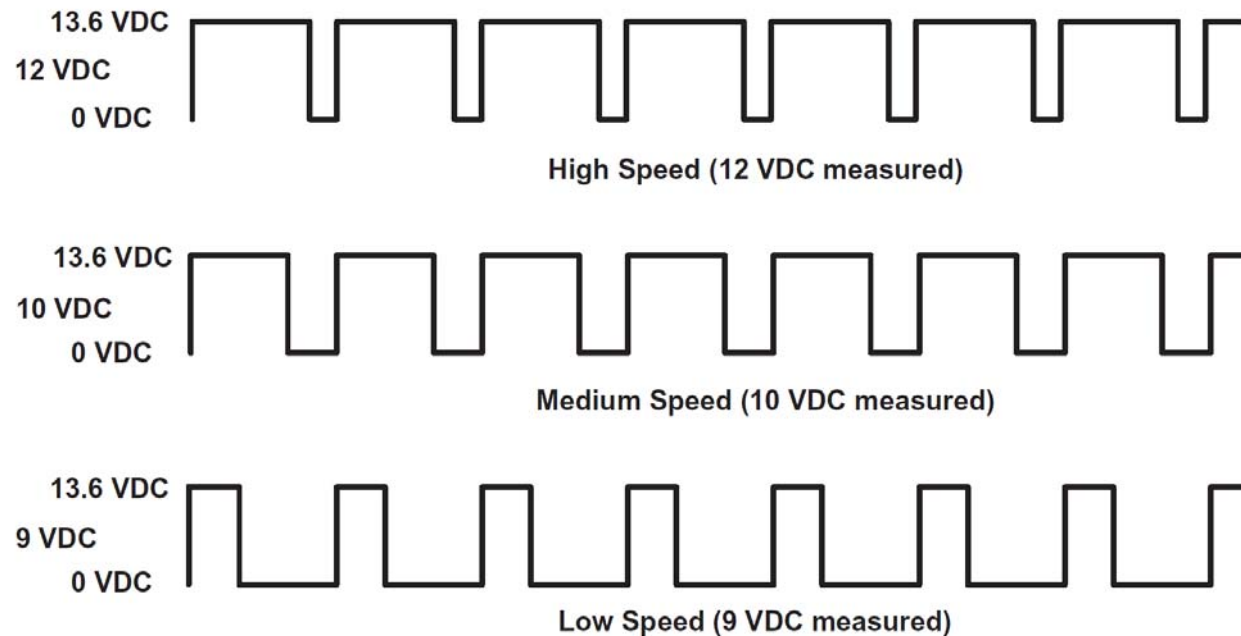

Main Electronic Board J2 Connector - Fans

Most fans receive supply voltage through the J2 pin 8 supply circuit as long as the refrigerator is connected to AC power.

The supply voltage can be measured by placing your meter leads across J2 pin 8 and J2 pin 3. You should read 12vdc. The presence of this voltage does NOT indicate that a fan should be operating.

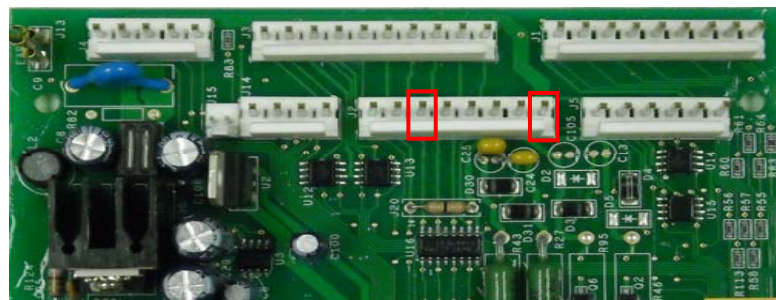
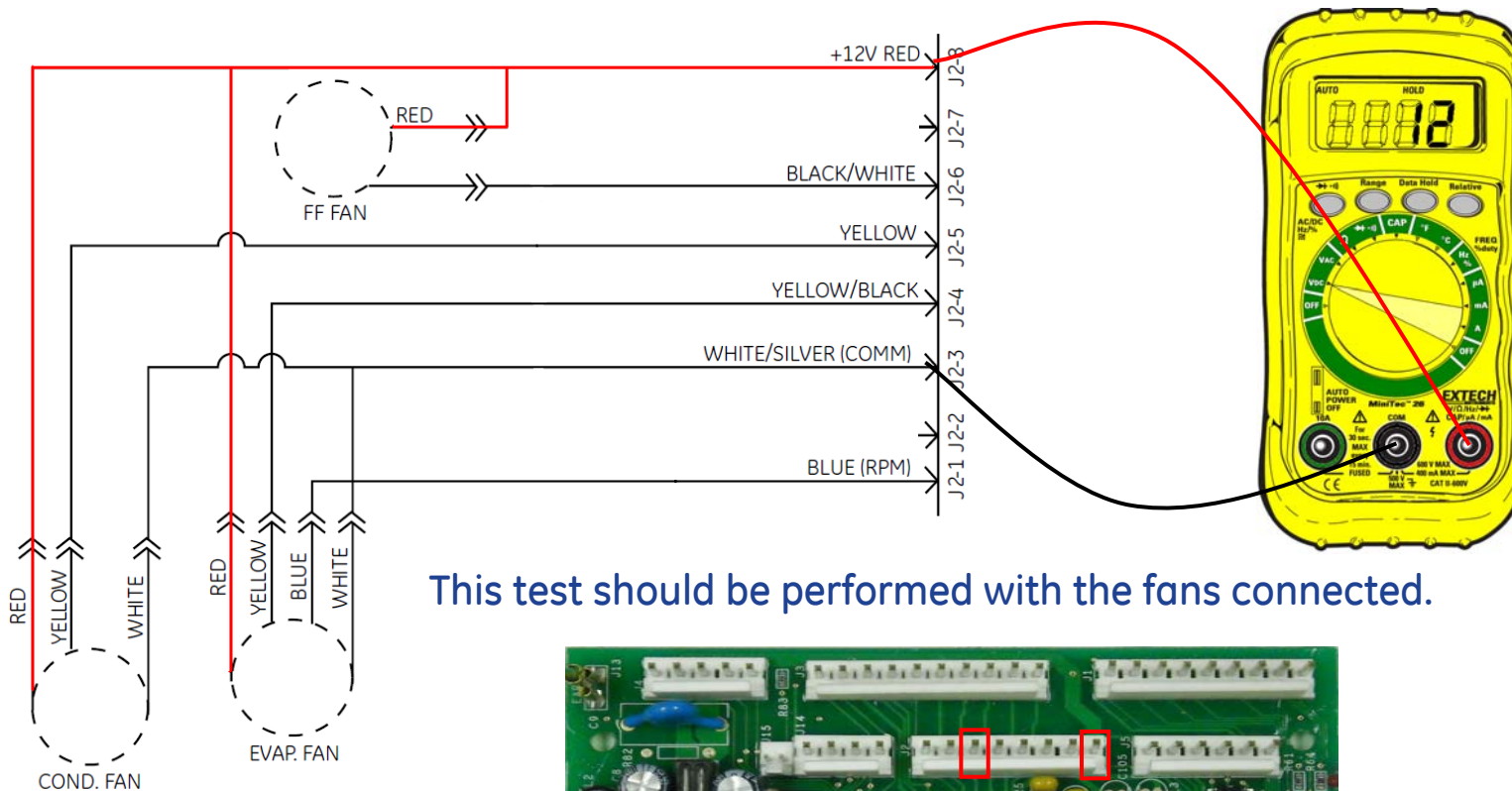

Main Electronic Board J2 Connector - Fans

Fan operation begins when the main board sends a “signal” voltage to the specific fan motor that needs to operate. This “signal” voltage is read between the J2 pin 3 and J2 pin 5 for the condenser fan, J2 pin 3 and J2 pin 4 for the evaporator fan, and J2 pin 6 and J2 pin 8 for the fresh food fan.

The voltage will depend on what speed the fan motor is supposed to operate at and the voltages will vary between 4vdc up to 12vdc.

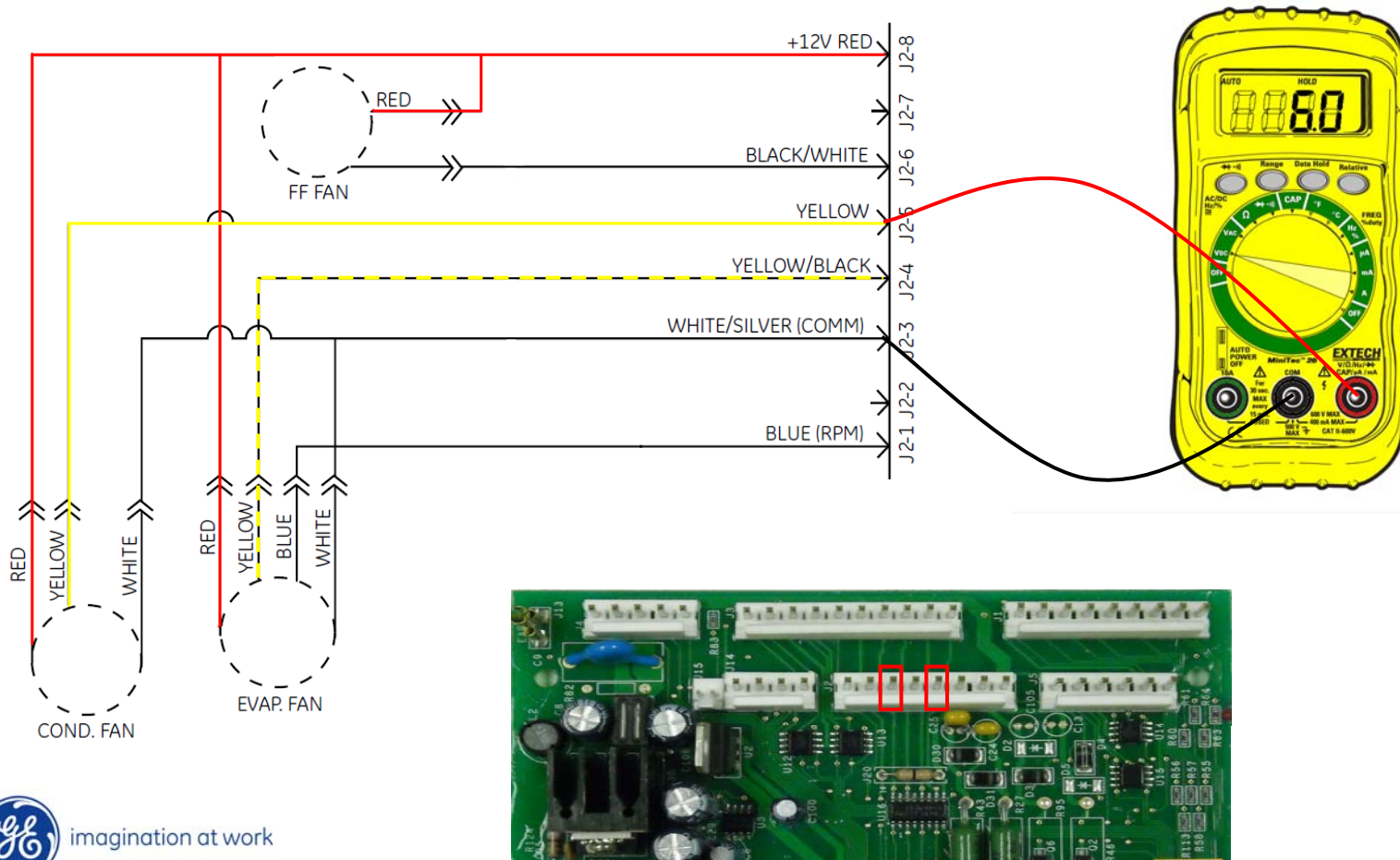

Main Electronic Board J2 Connector - Fans

Some fan motors send an RPM signal back to the main board, this signal lets the board monitor the fan speed. If this signal is not detected by the main board, the main board will default the fan to a fixed speed. This DC voltage feedback can be read from the RPM wire to the fan common connection.

Not all models use an RPM feed back, the schematic will show (RPM) for the feedback wire.

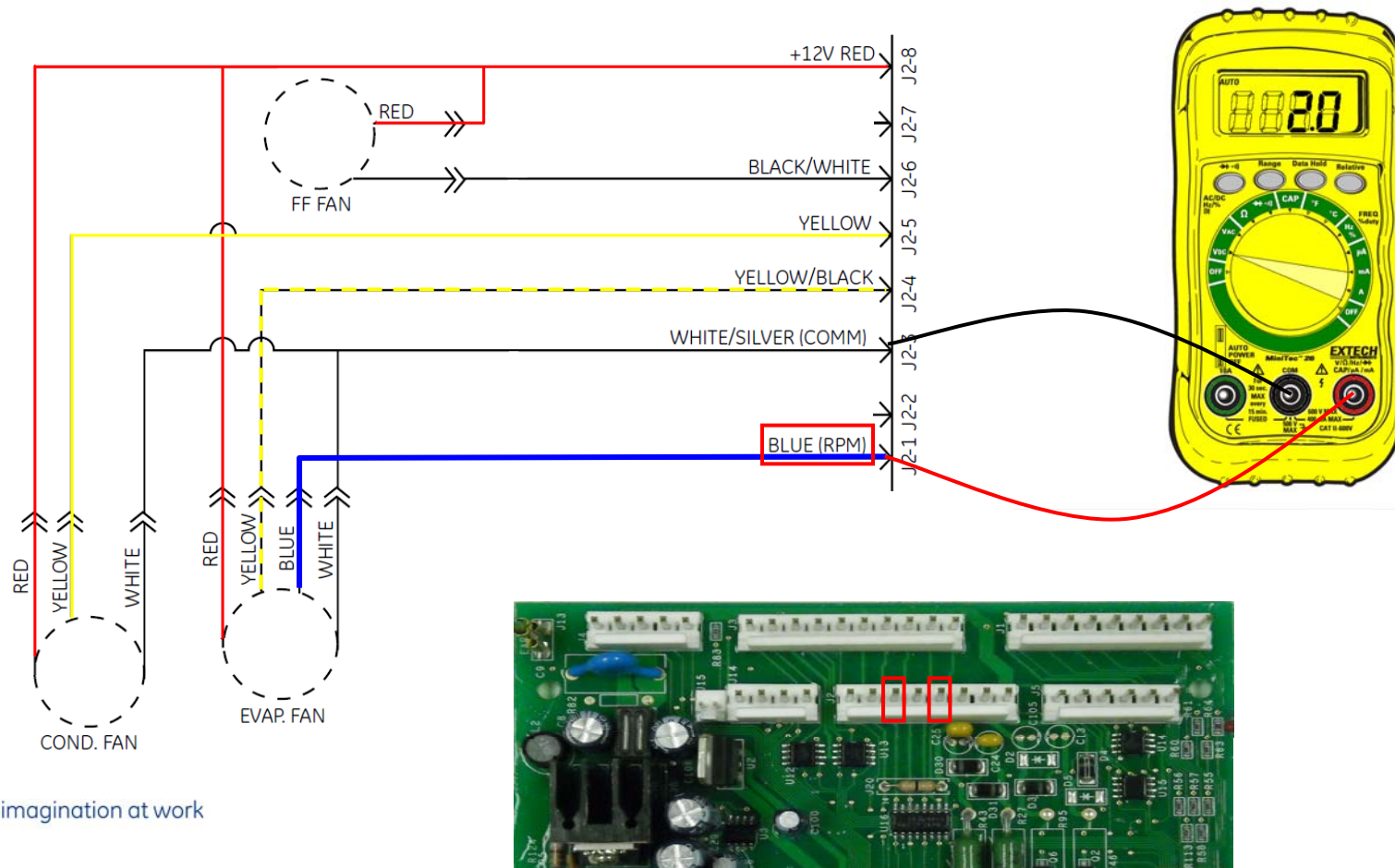

Main Electronic Board J2 Connector - Fans

In some cases a fan motor can fail and take down the 12vdc supply on the main board. If the refrigerator is not running and this voltage check fails; remove the J2 connector from the main board. If the refrigerator compressor starts, suspect a bad fan motor. You can isolate the condenser fan by unplugging it directly and then reinstall the J2 connector. If the refrigerator stops running, the evaporator fan is shorted, if not the condenser fan is shorted.

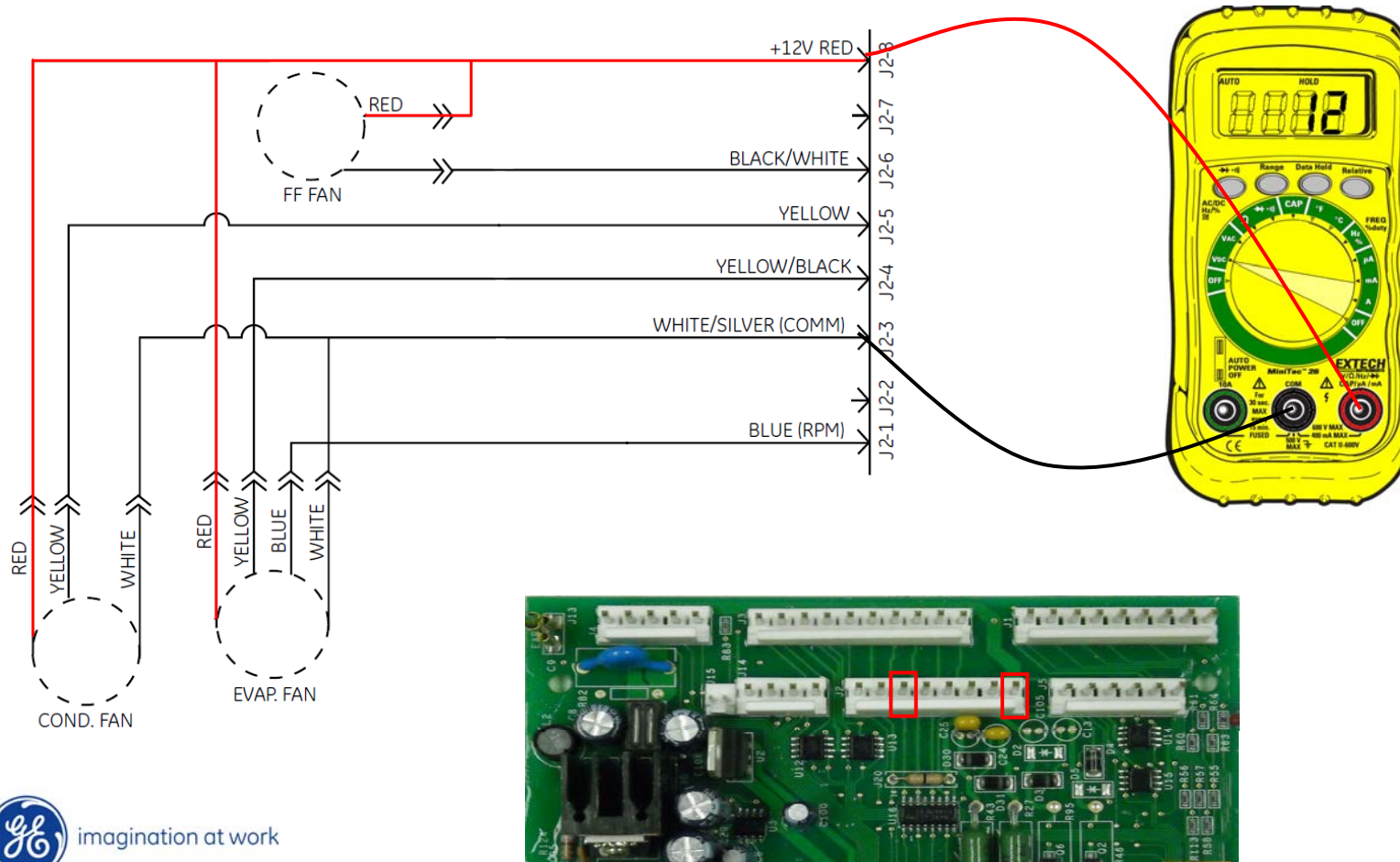

Main Electronic Board J2 Connector - Fans

Some main boards have ¼ watt resistors in the fan circuit directly located to the J2 connector. If you should find a burnt resistor, replace the main board and the fan motor – the fan motor has shorted out which caused the resistor to burn. The evaporator fan resistor is closest to the capacitors and the condenser fan resistor is farthest from the capacitors.

Evaporator Fan Resistor

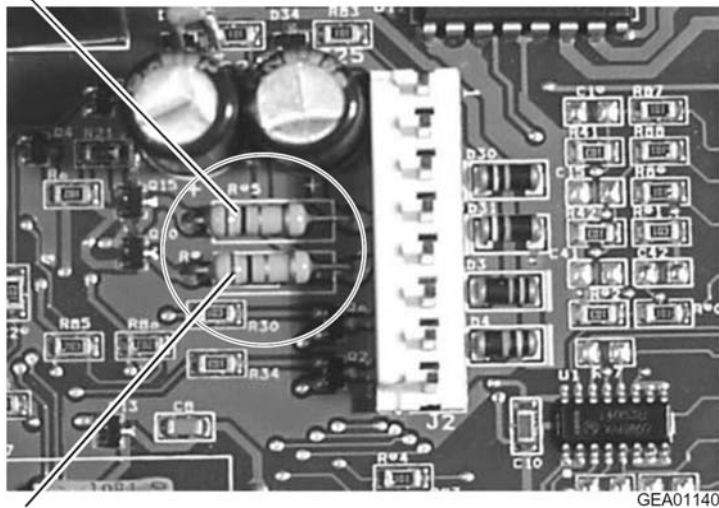

Condenser Fan Resistor

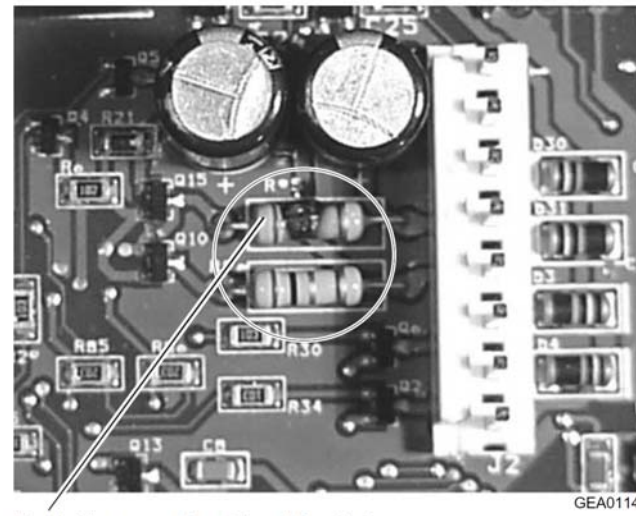

Bad Evaporator Fan Resistor

Main Electronic Board J2 Connector - Fans

Some fan motors do not use the J2-3 common connection directly. The common is switched through the main board circuitry. Such is the case with many of the smaller fans in the refrigerator. In the case of the fresh food fan you can see the common is on the J2-6.

Use the diagnostic function to turn on the FF fan (100% run) diagnostic code 1-2 and check for voltage at the J2-8 fan 12vdc to the J2-6.

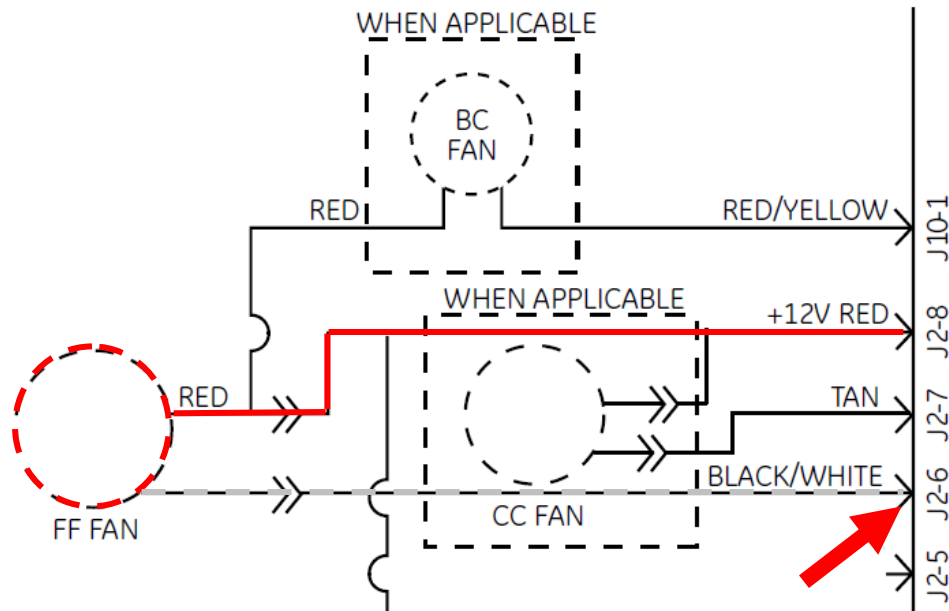

Wire colors can vary, check the schematic with the unit.

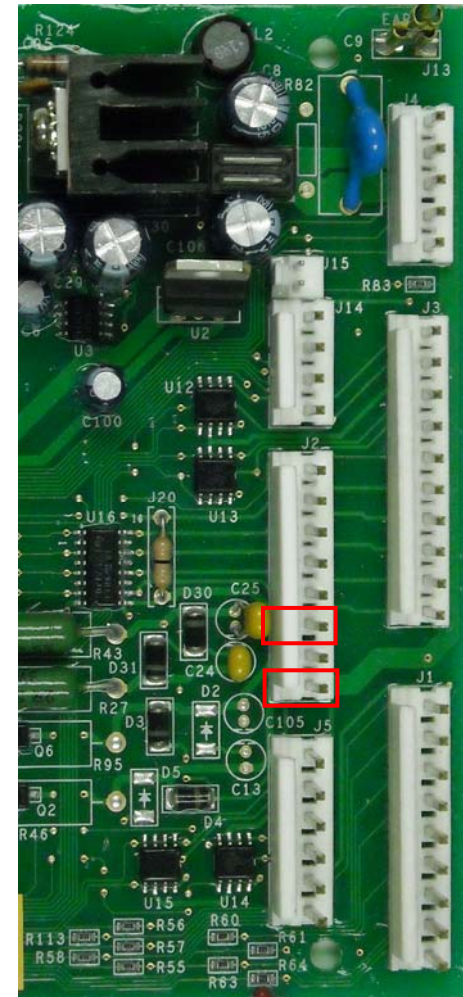

Main Electronic Board J2 Connector - Fans

The CC fan is the fan motor that circulates air through the climate controlled drawer in the fresh food section “Custom Cool Drawer.” If you do not hear this fan activate when you operate the CC customer controls; “Quick Chill & Quick Thaw” check the DC output voltage at J2-7 to J2-8.

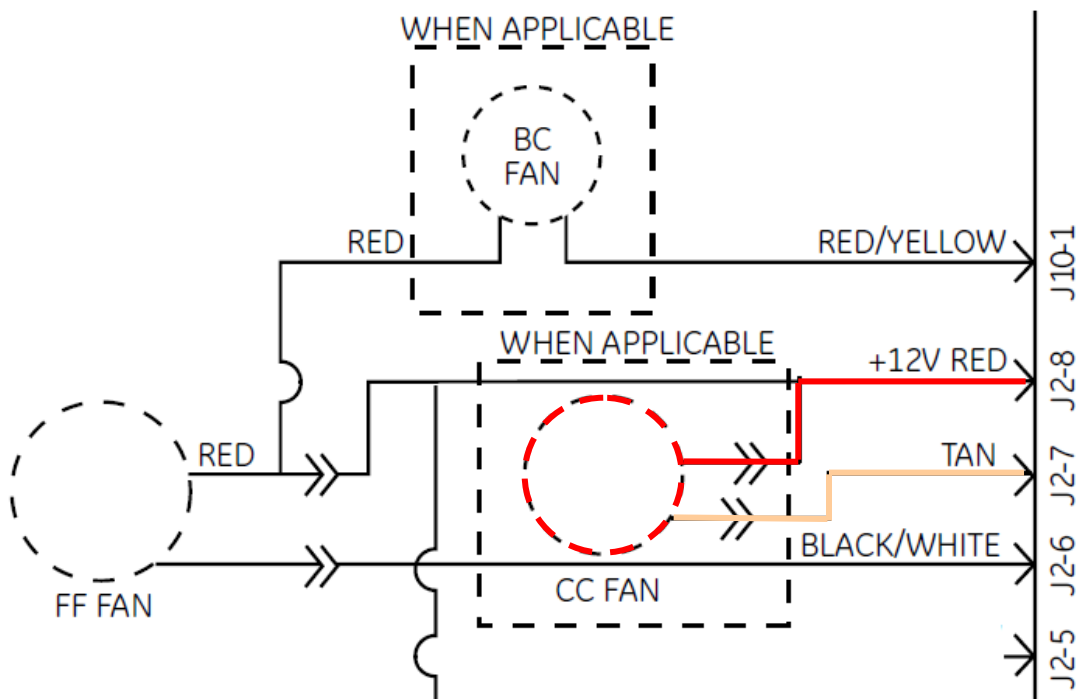

Main Electronic Board J2 Connector - Fans

The "Quick Freeze" fan is located in the freezer, just as with the CC fan; use the customer controls to see if the fan operates. If not, check for DC voltage at the J2-2 over to the J3-3 connector.

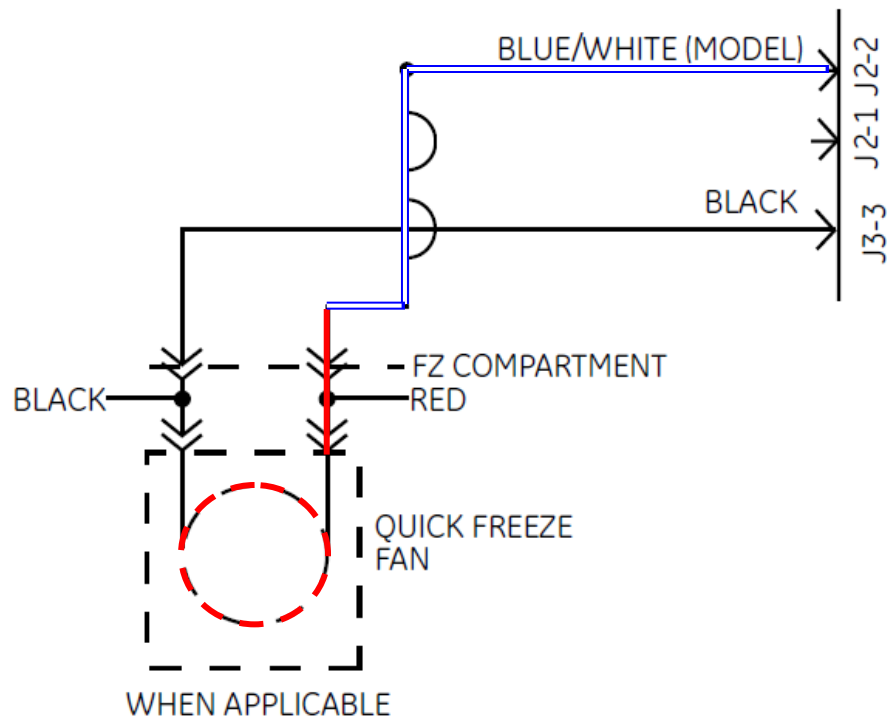

Main Electronic Board J2 Connector - Fans

The Beverage Center on dual evaporator models is a cooled compartment on the fresh food door. The temperature in this compartment is controlled by a fan in the bottom rear of the compartment by the FF evaporator "BC FAN." Use the customer controls to turn the beverage center ON, the fan should run for approximately 10 seconds. To test "operate" this fan you can bypass the main board using your meter.

Setup your meter for Amps and check from J3-1 to J2-3 (fan common), this will bypass the main board to activate the fan motor.

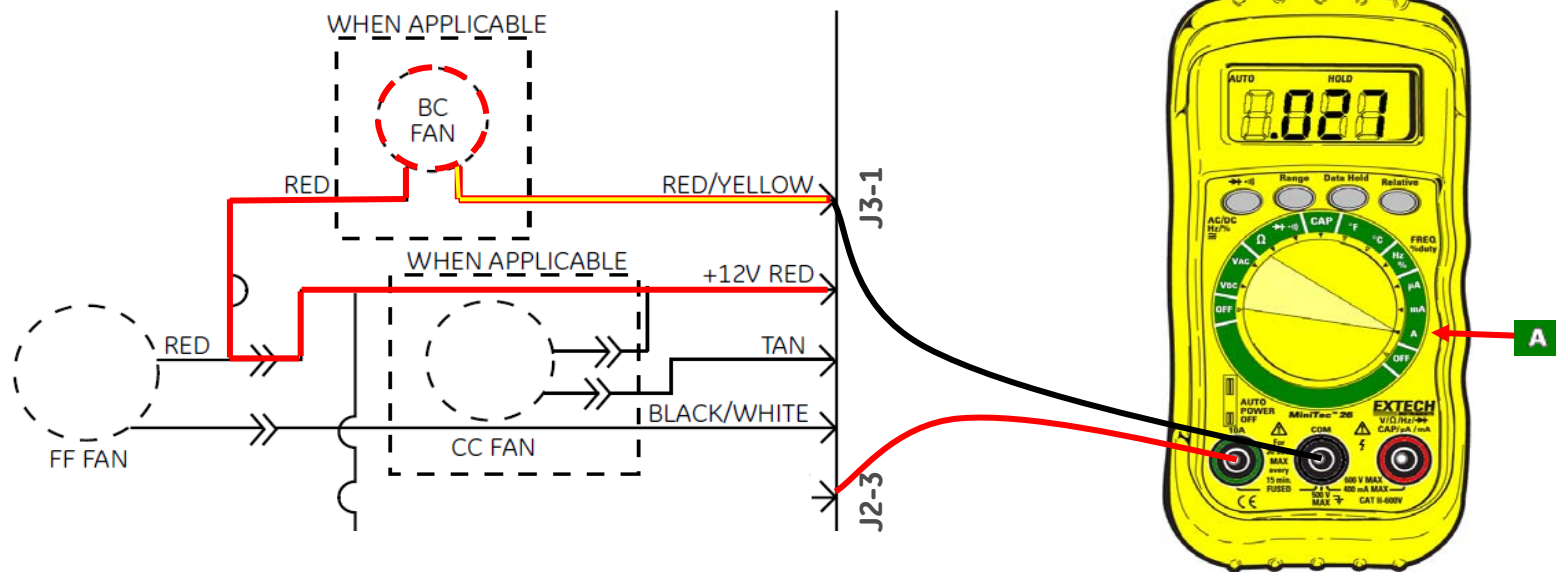

Note: This test can be used to check the operation of any fan motor.

Be sure to reset your meter back to voltage/resistance before performing any other tests.



Wire colors and terminals can vary, check the schematic with the unit.

Main Electronic Board J5 Connector – CC Damper(s)

The J5 connector controls the Custom Cool Drawer dampers and receives temperature information from the drawer thermistor. You can operate the dampers and check for function of the doors by selecting “Quick Chill” with the customer controls. To check damper voltages read across the two wires that feed the damper motor. Forced diagnostic function code 1-0.

Operational voltage is 12vdc when damper motor is activated.

The CC drawer thermistor resistance can be read from J5-5 to J5-6. When the drawer is not in use, the temperature of this drawer will be in the mid to low 40's.

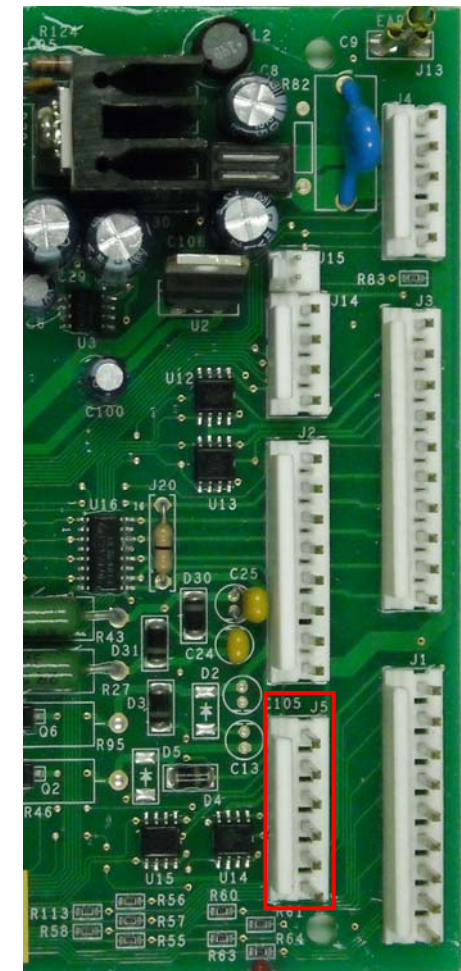
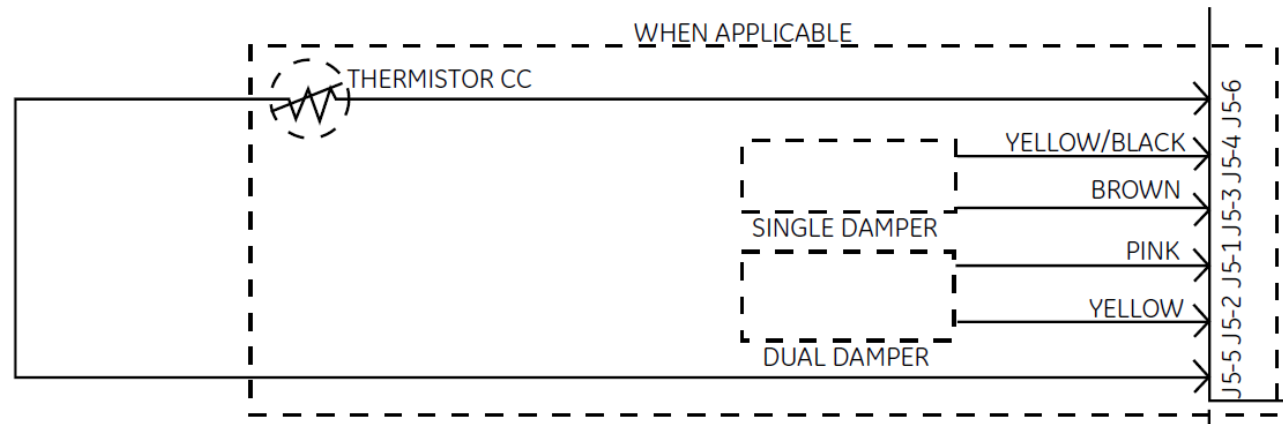

Main Electronic Board J14 Connector

Precise fill dispenser models utilize a flow meter to deliver a precise amount of water selected by the consumer. To check the flow meter circuit, test for a constant 12vdc between red and black and 6-7vdc from red to white at the beginning of water dispense. If voltages are correct, replace the flow meter. If the voltages are not correct check the connections and cabinet wiring.

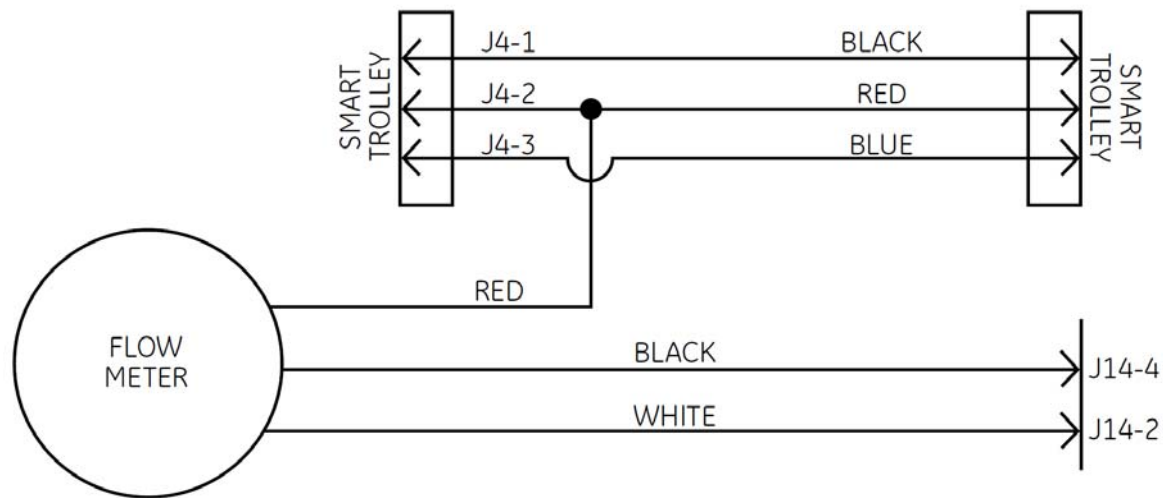

CONTROL BOARD PIN DEFINITIONS

CONNECTOR	PIN	INPUT	OUTPUT	FUNCTION
J14	2		VDC	Flowmeter - 6.5-7 VDC when first activated.
J14	4	VDC		Flowmeter - 13.6 VDC.

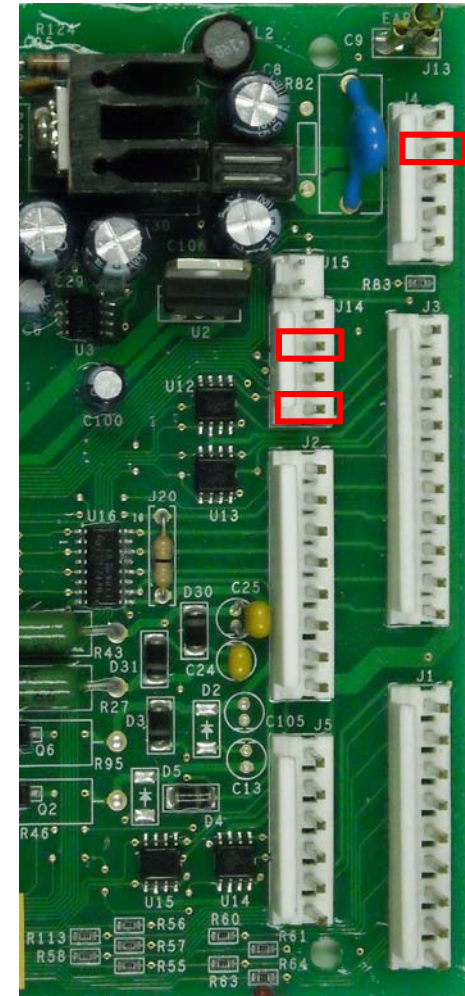

Fresh Food LED Lighting

Some model refrigerators utilize LED lighting in the ceiling of the fresh food section. A transformer in the compressor compartment receives 120vac from the door switch(s) and outputs approximately 36vdc to the LED bank.

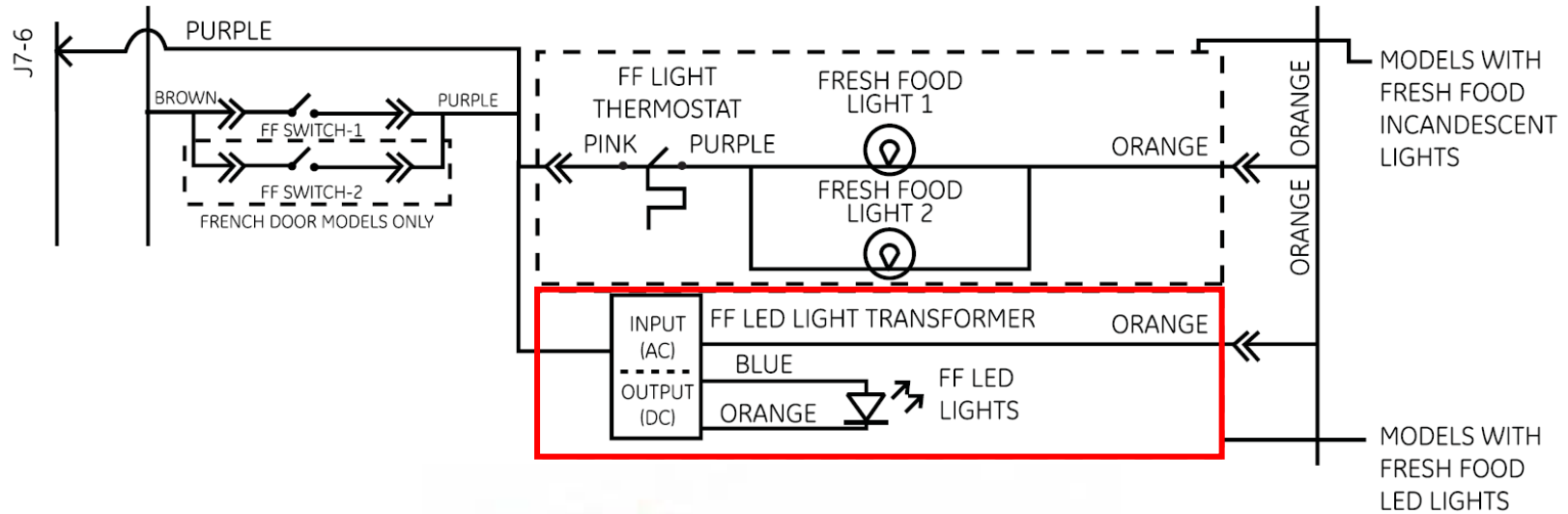

All LED Lighting Freezer and Fresh Food Sections

Some model side by sides use LED lighting in both compartments instead of mixing LED and incandescent bulbs. Unlike previous models where the main board **did not** control interior lighting; the main board **does** control the LED lamps in ALL LED units.

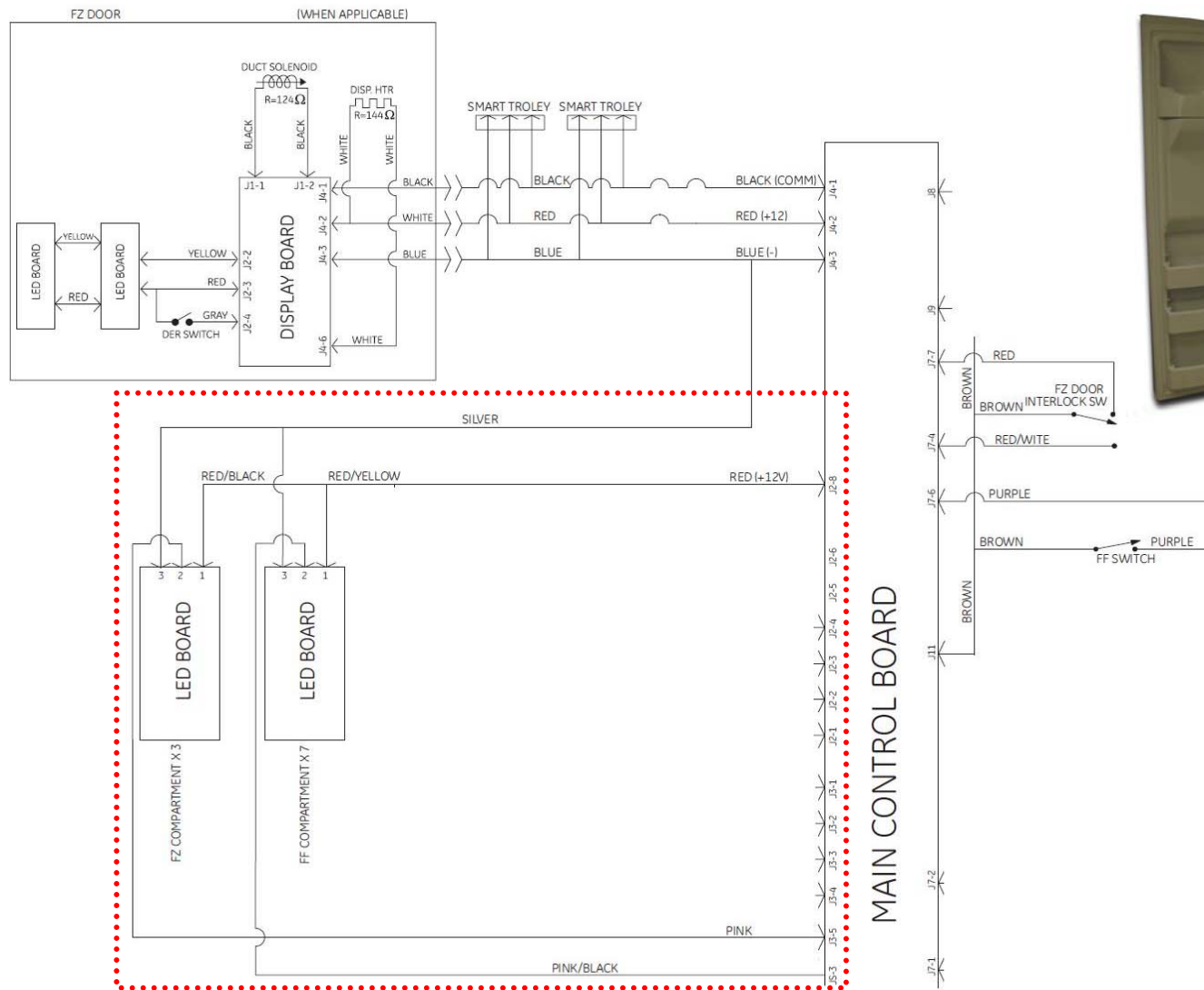

Wire colors and terminals can vary, check the schematic with the unit.

All LED Lighting Freezer and Fresh Food Sections

Anytime the refrigerator is plugged in there is 12vdc supplied to pins 1 and 3 on each of the LED boards. When the door is open the main board sends an additional 12vdc to pin 2 to activate the LED lighting. The 12vdc voltage from the main board can be read at pins 2 to 3 at the LED board or at the main board reading back to board common.

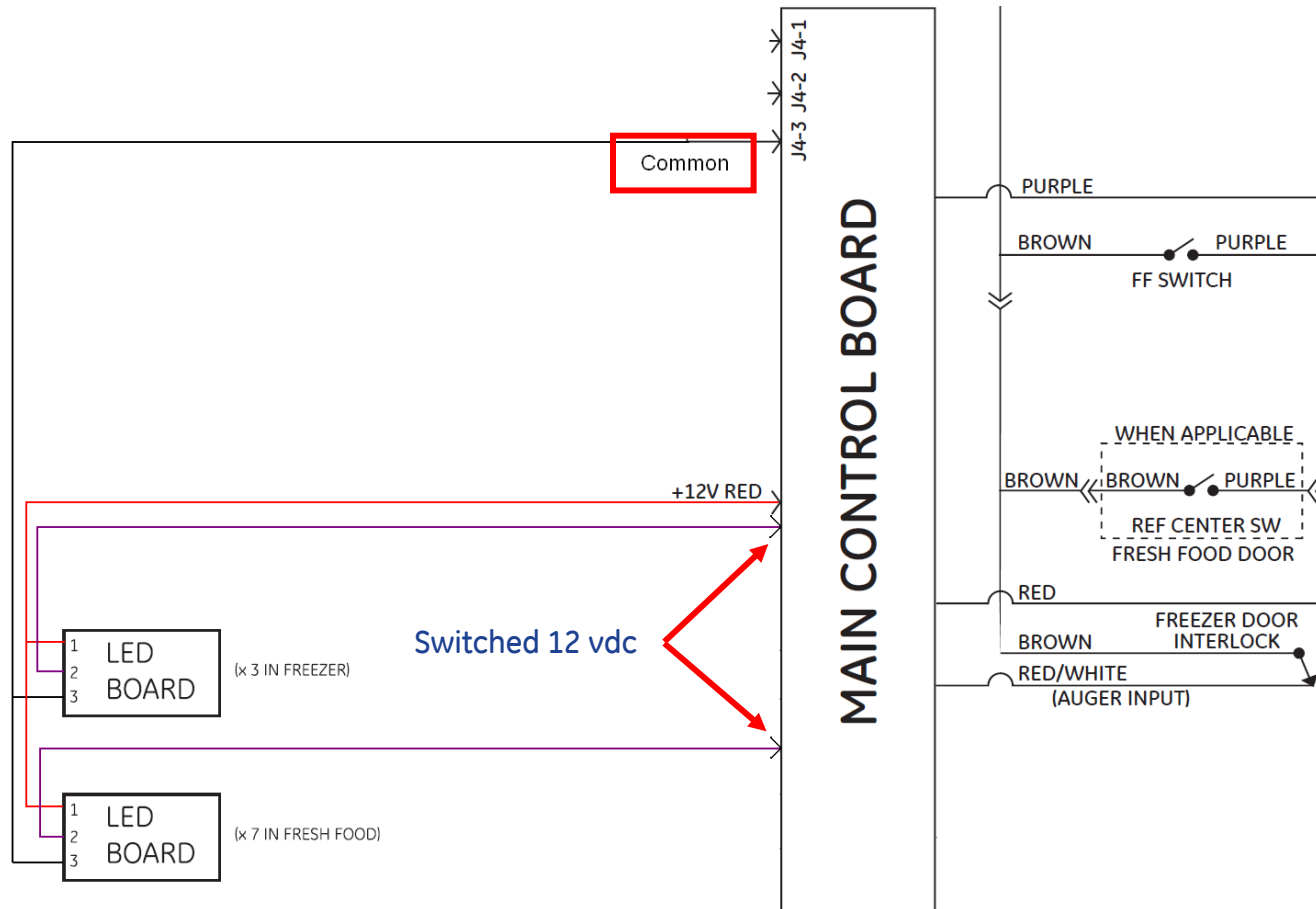

Wire colors and terminals can vary, check the schematic with the unit.

All LED Lighting Freezer and Fresh Food Sections

Each LED board contains 3 separate LED lights and all of the LED boards should activate at the same time when the door is opened. There is a delay for the LEDs to obtain full intensity.



LED Lights

The LED boards snap into the recess on two standoffs.

