

# Electronic Refrigerator Diagnostics

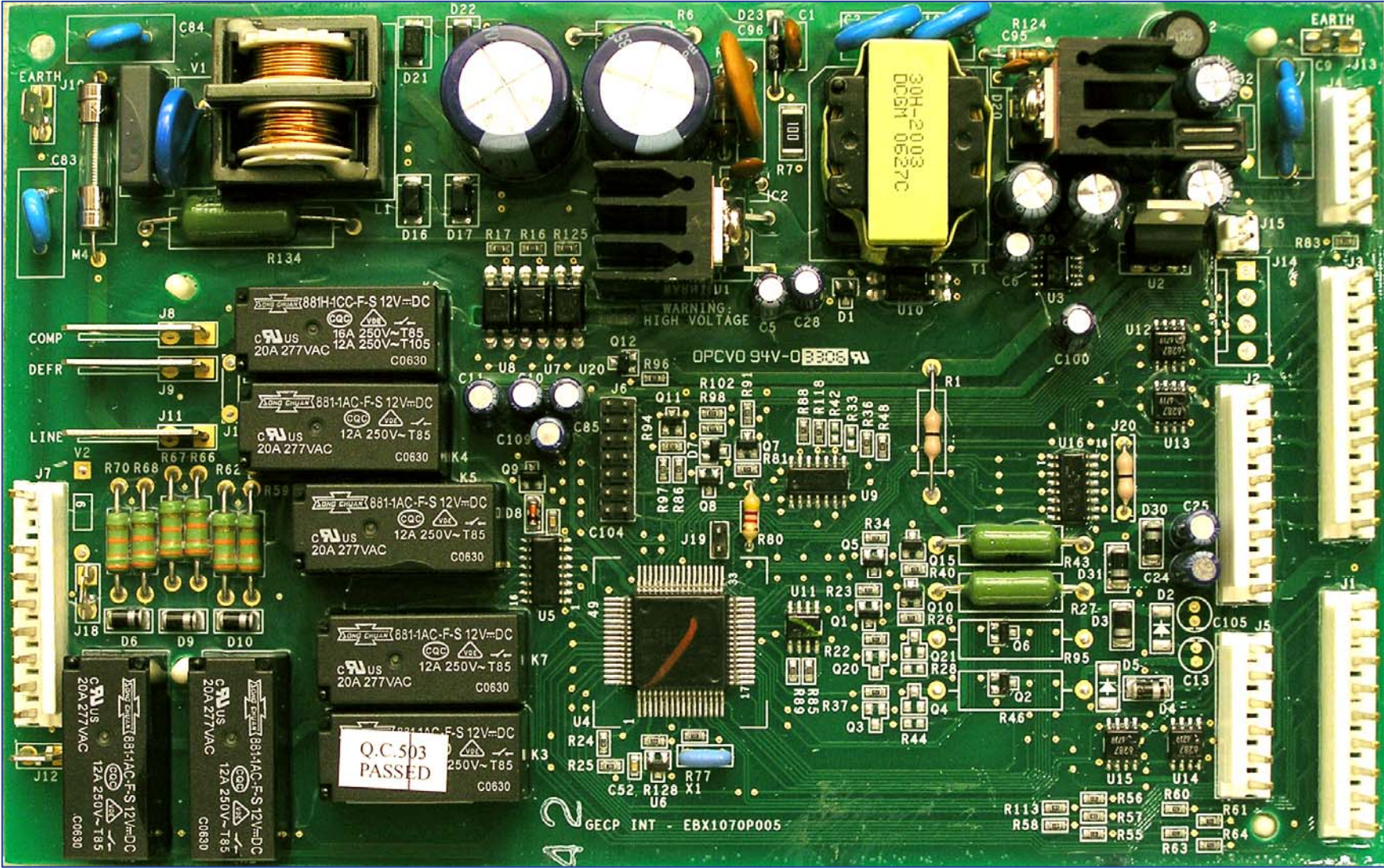

## **IMPORTANT SAFETY NOTICE**

The information in this presentation is intended for use by individuals possessing adequate backgrounds of electrical, electronic, & mechanical experience. Any attempt to repair a major appliance may result in personal injury & property damage. The manufacturer or seller cannot be responsible for the interpretation of this information, nor can it assume any liability in connection with its use.

### **WARNING**

To avoid personal injury, disconnect power before servicing this product. If electrical power is required for diagnosis or test purposes, disconnect the power immediately after performing the necessary checks.

### **RECONNECT ALL GROUNDING DEVICES**

If grounding wires, screws, straps, clips, nuts, or washers used to complete a path to ground are removed for service, they must be returned to their original position & properly fastened.



## Main Electronic Board

**Caution:** When servicing or testing in the main board area, many components and connections are electrically hot to ground. Be sure to use proper service procedures and protection devices.

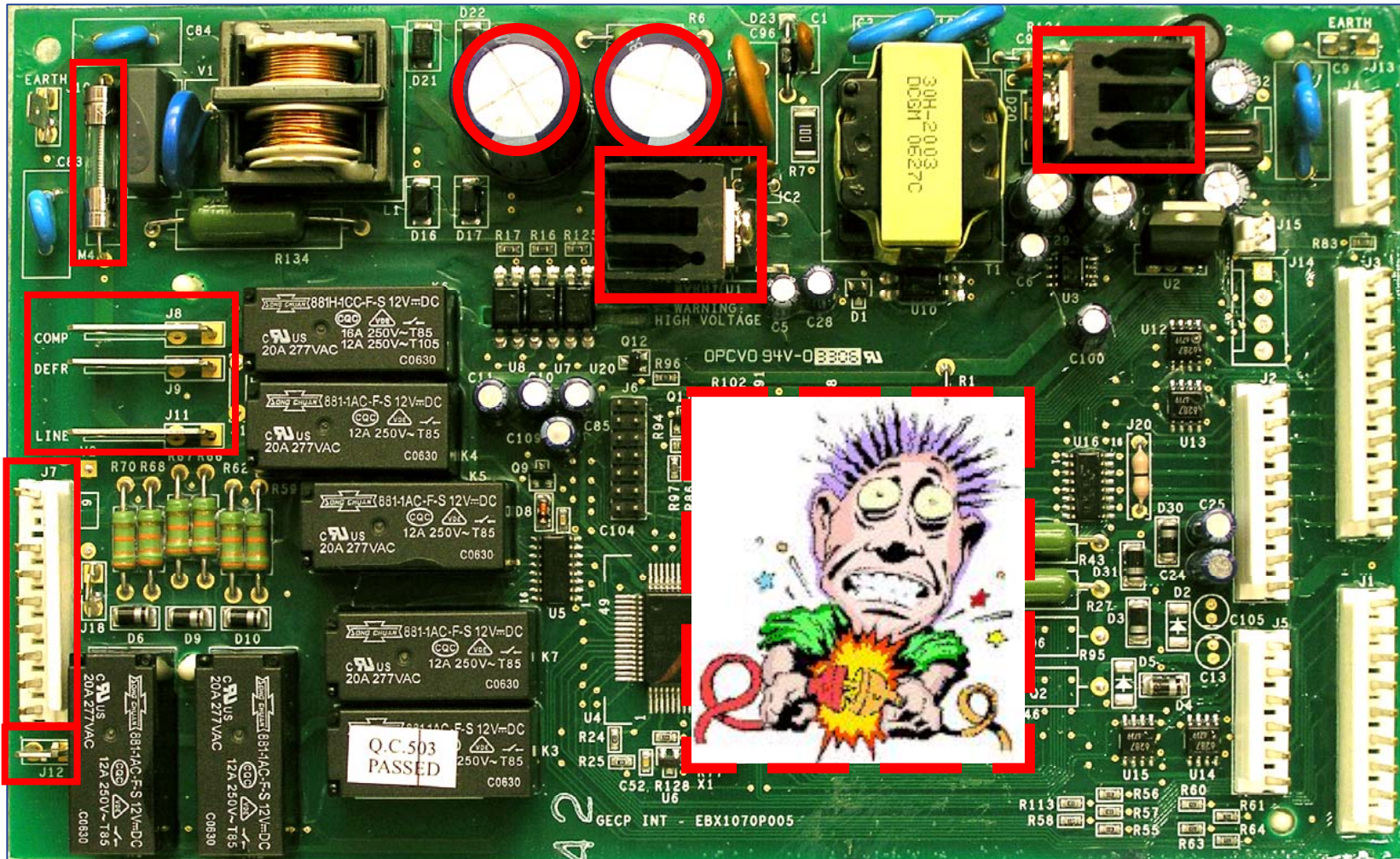



## Electronic Diagnostic Test Mode

All the GE electronic refrigerators have a Diagnostic Mode that is incorporated in the software in each main electronic board. This Diagnostic Mode will test certain components and operate others.

To activate this diagnostic test feature on an electronic refrigerator, you will need a touch pad control with at least 5 key pads; otherwise you will have to install the additional diagnostic tool.

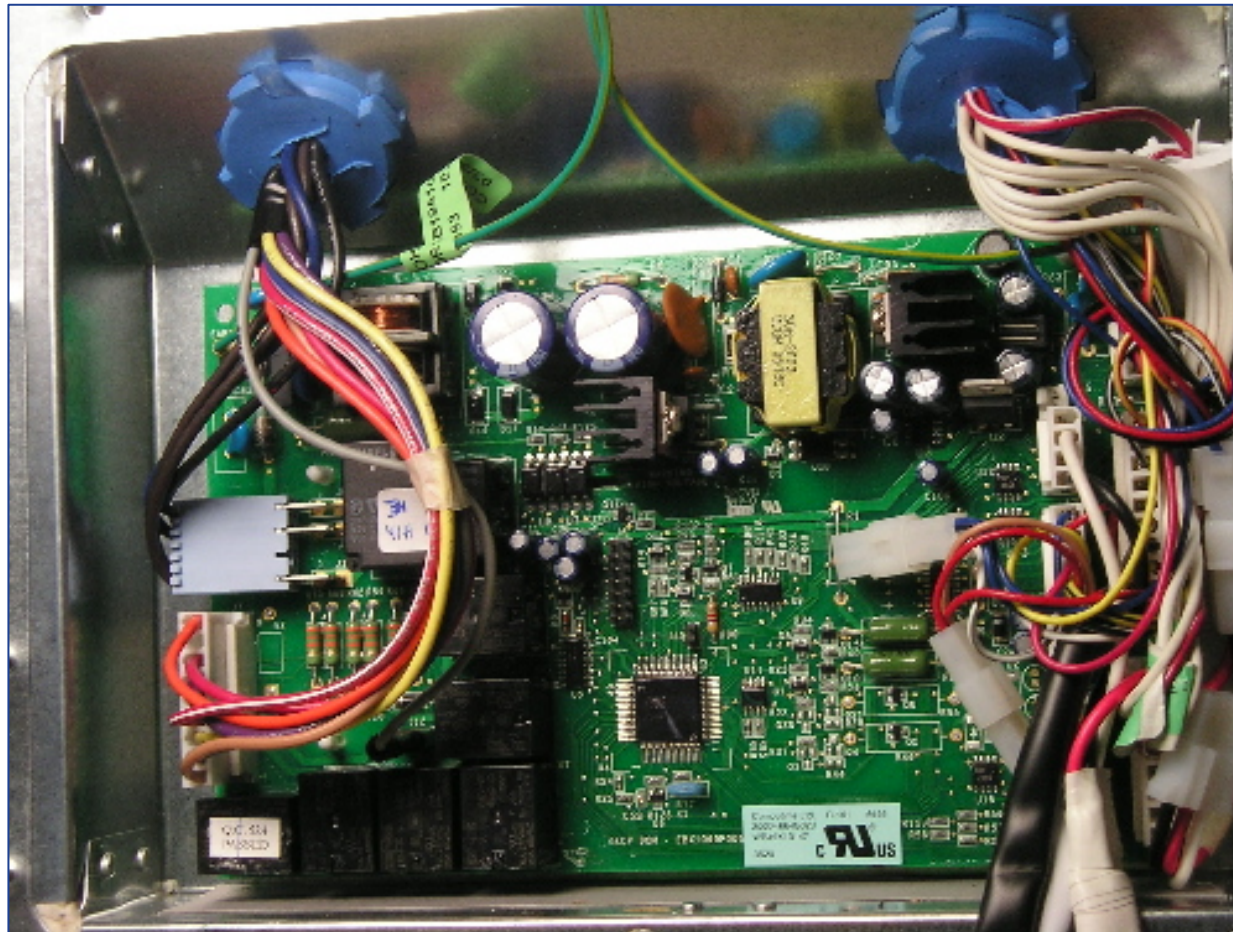

## Diagnostics Aid Kit

The diagnostic aid kit may assist the technician to functionally test individual components.

A diagnostic aid kit can be assembled and consists of a key pad temperature control assembly and wire harness. The parts required are WR55X10390 and WX05X14999.

Using the kit, diagnostics can be performed by removing the base grill and plugging into the diagnostic aid wire harness located on the left side. Diagnostics can also be performed by accessing the main board on the back of the refrigerator and plugging into the harness extended from the board.

**Note:** After plugging in the diagnostic aid kit, if the display is blank, press and release any of the temperature pads. The display will show actual temperatures.

Diagnostic Aid - Front Access



Diagnostic Aid - Main Board Access

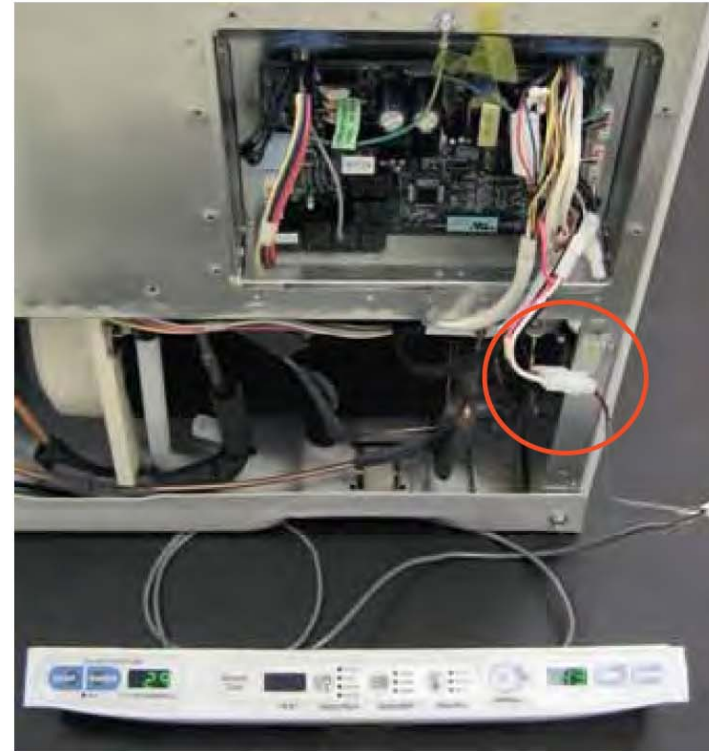

# Electronic Diagnostic Test Mode

## Control Diagnostics

Enter the diagnostic mode by pressing both the freezer temperature (COLDER and WARMER) pads and the refrigerator temperature (COLDER and WARMER) pads simultaneously. All four pads must be held for approximately 3 seconds. Blinking "0"s in both displays indicate the refrigerator has entered the test mode.

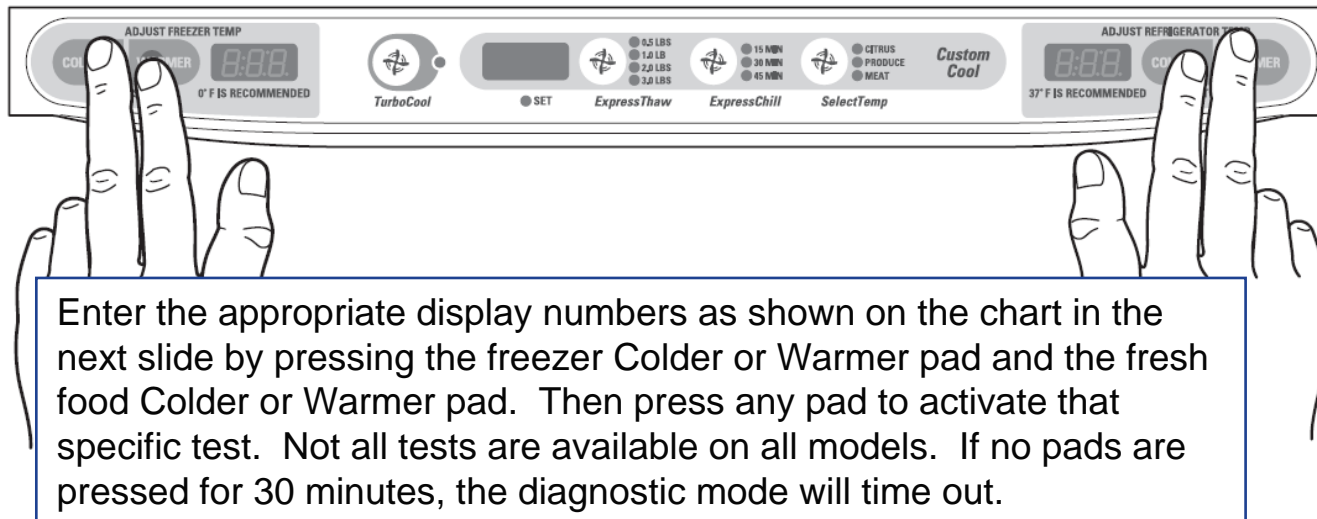



## Electronic Diagnostic Test Mode

Freezer Display	Fresh Food Display	Diagnostics	Results	Comments
0	7	Control and Sensor System Test	Checks each thermistor in order.	<b>See Note 1.</b>
1	0	Dampers Test	Custom Cool™ damper will open, close after 10 seconds, pause briefly, then single damper will open for 10 seconds.	Test will not start for approximately 20 seconds after pad is depressed.
1	1	Fan Test	Cycles through each fan for 5 seconds.	
1	2	100% Run Time	Sealed system on 100% of the time. Times out after 1 hour.	
1	4	Defrost Test	Toggles on the defrost cycle. <b>See Note 2.</b>	Must press again to turn heater off. <b>See Note 2.</b>
1	5	Main Control Reset/Test Exit	Causes a system reset and exits test mode.	

**This test will not indicate failure for thermistors out of spec**

**This test will also cycle the FF damper on single evap models**

**This test will attempt to turn ON the compressor if it is OFF**

**Note 1:** Display order is #1 = Fresh Food Evaporator Thermistor, #2 = Fresh Food Thermistor, #3 = CustomCool™ Thermistor, #4 = Freezer Evaporator Thermistor, #5 = Freezer Thermistor.

Thermistor test results are: P = Pass, 0 = Fail, S = Short to 5 VDC, B = Defective board (replace main control).

**Note 2:** You **must** enter the defrost test again to toggle the defrost heater off at the end of the test. The heater will not come on if the evaporator thermistor is above 70°F (21°C).

# Inverter Compressor Testing

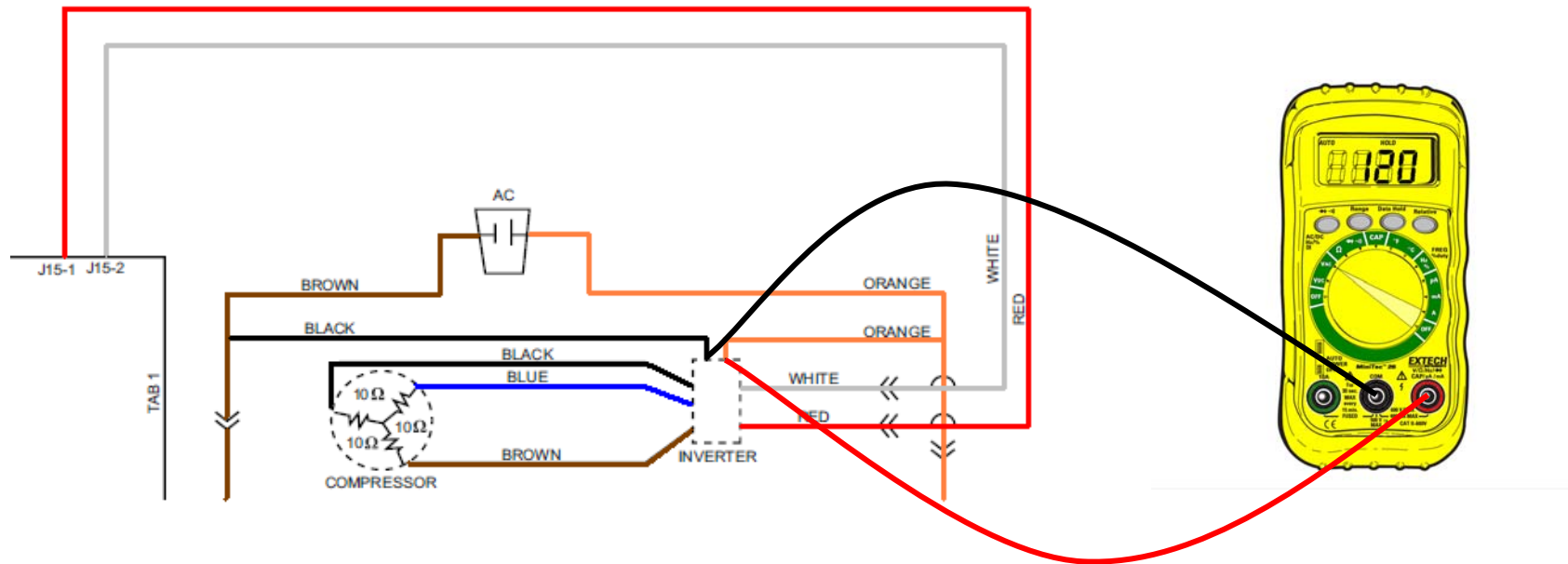

- 1) Using diagnostic mode or the diagnostic aid, place the unit into 100% run mode, code 1-2.
- 2) See if you can detect compressor operation.
- 3) If the compressor does not operate, pull the refrigerator away from the wall.
- 4) Remove the rear machine cover.
- 5) Set meter to ACV.
- 6) Place meter leads on Inverter wire connector (Black and Orange).
- 7) Should read line voltage – if not check wires and repair, otherwise go to next step.





Check the voltage with the connector plugged into the inverter harness.

# Inverter Testing

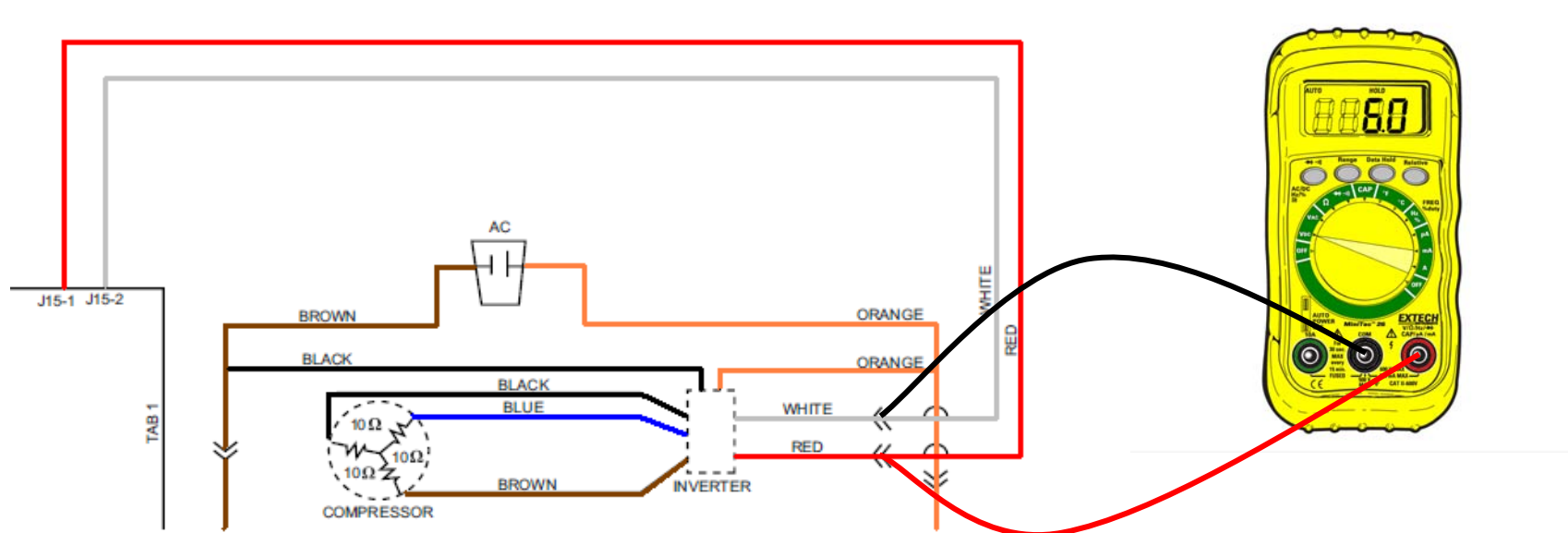

**Note:** When measuring signal voltage (from the main control board) at the inverter, a reading of 4-6 VDC will be measured with all wires connected. If the inverter wiring is disconnected, the board output will measure between 10-12 VDC.

- 8) Set meter to DCV or Hz.
- 9) Place meter leads on Inverter wire connector (White and Red).
- 10) You should read between 4vdc and 6vdc or between 57Hz and 104Hz – if not go to next step, otherwise check compressor windings – any two terminals should read 10Ω and also check each terminal to case, replace compressor if any windings are defective – if not, replace Inverter.
- 11) Remove cover from Main Control Board.
- 12) Place meter leads on J15 pin 1 and J15 pin 2.
- 13) You should read between 4vdc and 6vdc or between 57Hz and 104Hz – if not replace Main Board.
- 14) If correct readings at J15 pin 1 and J15 pin 2, replace wire harness that connects main board to the inverter.

# Inverter Compressor Operation

The inverter receives commands from the main board and will send a Pulse Width Modulated (PWM) run signal between 4vdc and 6vdc effective voltage to the inverter. If your meter can read frequency, the reading will be between 57Hz and 104Hz. The inverter will select compressor speed (voltage output) based on this “signal”. A voltage/frequency “signal” from the main board (J15 pins 1 and 2) lower than 4vdc/57Hz or greater than 6vdc/104Hz indicates a faulty main board. The main board will only send a run “signal” to the inverter when the compressor should run.

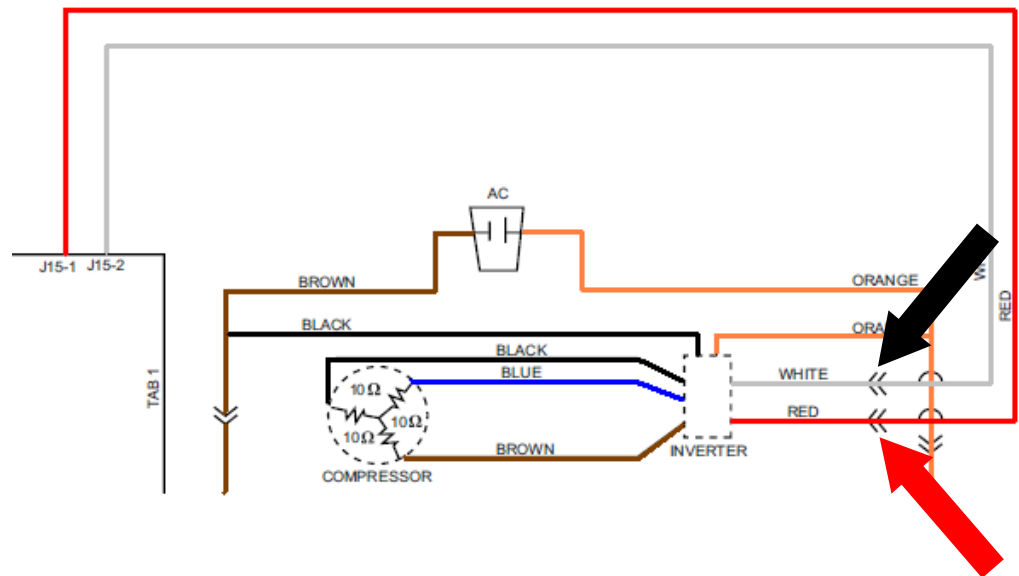



# Main Electronic Board Testing – Inverter Operation

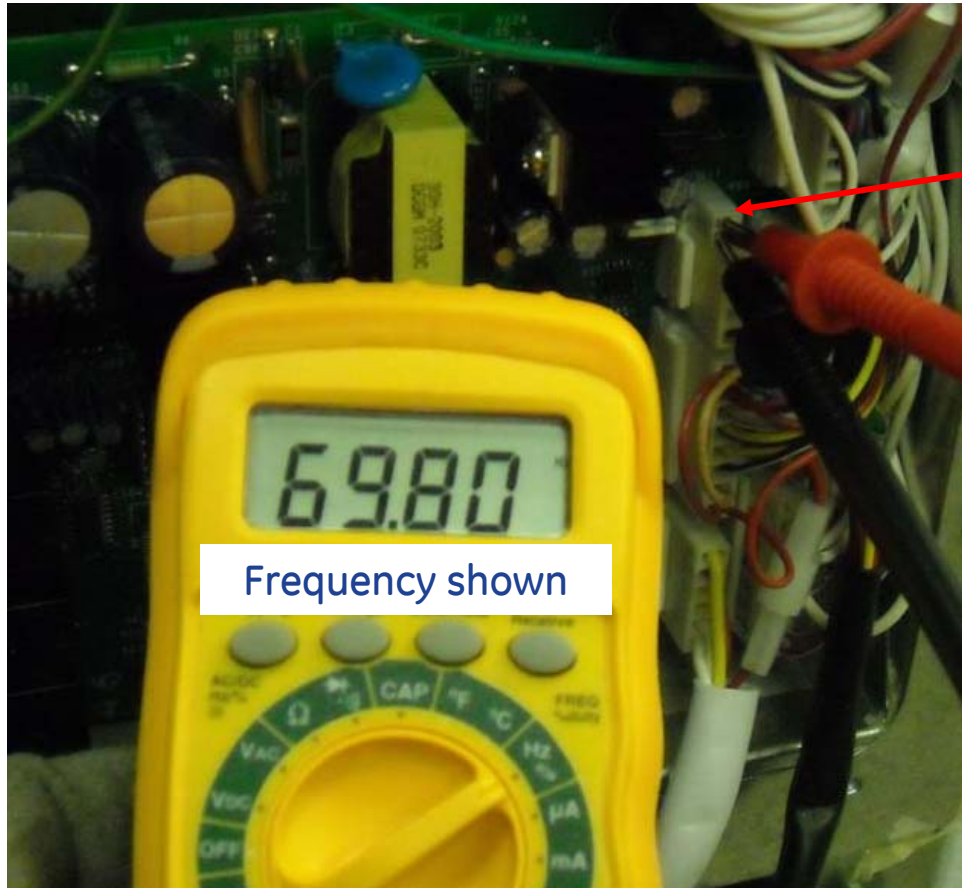

Frequency shown

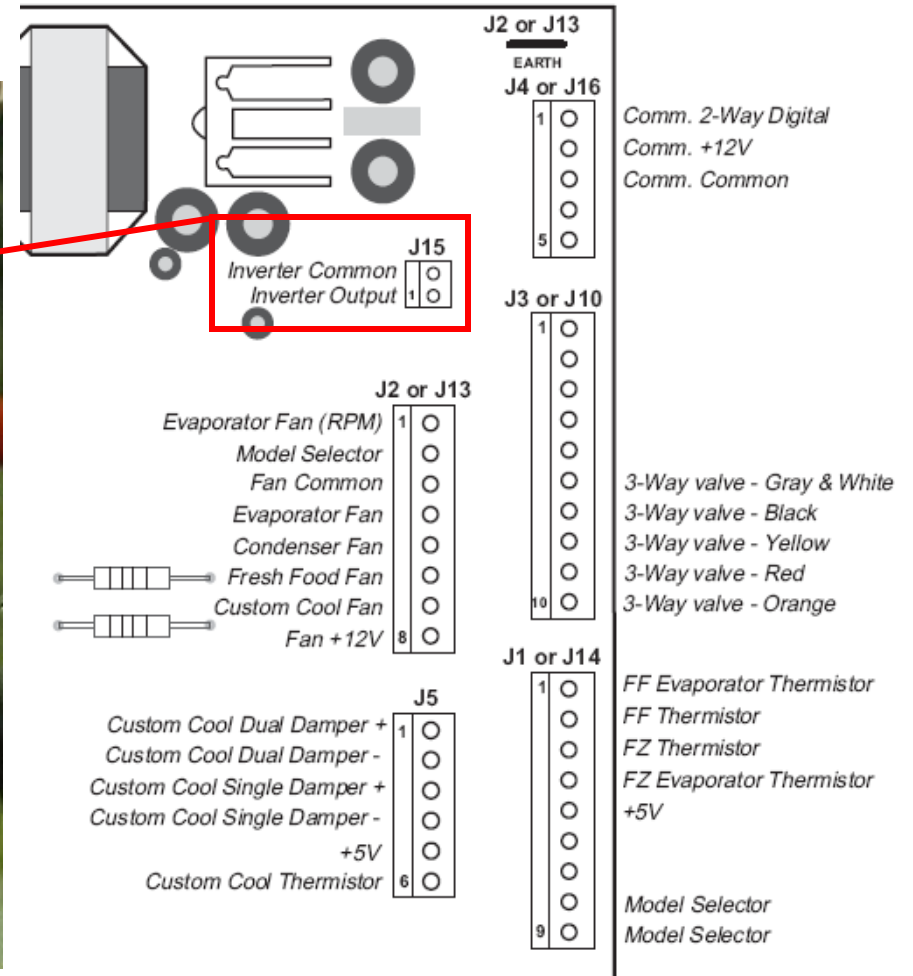

To test board signal for compressor operation, place your meter leads as shown in the above example.

Remember that the compressor gets it's voltage from the Inverter; but first the Inverter must get a "signal" from the main board of between 4vdc/57Hz to 6vdc/104Hz and this is measured between J15 pins 1 and 2.