



***1999 TOP MOUNT
REFRIGERATORS***

***PRODUCT INFORMATION
AND TECHNICAL GUIDE***

Frigidaire Brands

 **FRIGIDAIRE**

TAPPAN

 White-Westinghouse

Gibson

CONTENTS

SAFE SERVICING PRACTICES	2
SCHEMATIC, SERVICE DATA SHEET, AND REFRIGERANT CHARGE INDEXES	3 - 8
Frigidaire	3 - 5
Tappan	5
Universal / Multiflex*	6 - 7
Gibson	7
White Westinghouse	8
SERVICE DATA SHEETS	9 - 14
SCHEMATICS	15 - 23
TROUBLESHOOTING GUIDE	24 - 27
NOTES	28

* Universal / Multiflex models can be sold under any of the Frigidaire Company Brands

SAFE SERVICING PRACTICES - ALL APPLIANCES

To avoid personal injury and/or property damage, it is important that safe servicing practices be observed. The following are some limited examples of safe practices:

1. Do not attempt a product repair if you have any doubts as to your ability to complete it in a safe and satisfactory manner.
2. Before servicing or moving an appliance:
 - Remove the power cord from the electrical outlet, trip the circuit breaker to the **OFF** position, or remove the fuse
 - Turn off gas supply
 - Turn off water supply
3. Never interfere with the proper operation of any safety device.
4. **USE ONLY REPLACEMENT PARTS CATALOGED FOR THIS APPLIANCE. SUBSTITUTIONS MAY DEFEAT COMPLIANCE WITH SAFETY STANDARDS SET FOR HOME APPLIANCES.**
5. **GROUNDING:** The standard color coding for safety ground wires is **GREEN**, or **GREEN** with **YELLOW STRIPES**. Ground leads are not to be used as current carrying conductors. It is **EXTREMELY** important that the service technician reestablish all safety grounds prior to completion of service. Failure to do so will create a hazard.
6. Prior to returning the product to service, ensure that:
 - All electric connections are correct and secure
 - All electrical leads are properly dressed and secured away from sharp edges, high-temperature components, and moving parts
 - All uninsulated electrical terminals, connectors, heaters, etc. are adequately spaced away from all metal parts and panels
 - All safety grounds (both internal and external) are correctly and securely connected
 - All panels are properly and securely reassembled

WARNING

This service manual is intended for use by persons having electrical and mechanical training and a level of knowledge of these subjects generally considered acceptable in the appliance repair trade. Frigidaire Company cannot be responsible, nor assume any liability, for injury or damage of any kind arising from the use of this manual.

FRIGIDAIRE MODELS					
Model	Service Data Sheets		Schematic Page #'s	R-134a Refrigerant Charge	Energy Efficiency Rating (kwh/yr)
	Number	Page			
F44N18CEW7	218758400	10	15 - 16	5.00	683
F44N18DTW0	218758400	10	15 - 16	5.00	683
F44N21CEW4	218755000	9	15 - 16	5.00	741
F44P21ATW0	218755000	9	15 - 16	5.50	741
F44P21ATW1	218755000	9	15 - 16	5.50	741
F44Q22JTW1	218771400	11	17 - 18	4.50	740
F44Q22JTW2	218901900	14	17 - 18	4.50	740
FRT13CRHW0	218758400	10	15 - 16	3.75	586
FRT13GRHW0	218758400	10	15 - 16	3.75	586
FRT16CNHW1	218758400	10	15 - 16	5.00	639
FRT16CNHW3	218758400	10	15 - 16	4.50	639
FRT16CRHW0	218755000	9	15 - 16	3.75	639
FRT16DNHW0	218755000	9	15 - 16	3.75	639
FRT16ICRHW0	218755000	9	15 - 16	3.75	639
FRT16NRGW2	218755000	9	15 - 16	3.75	639
FRT16NRGW4	218755000	9	15 - 16	3.75	639
FRT16PRGW4	218755000	9	15 - 16	3.75	639
FRT18DRHW0	218758400	10	15 - 16	5.00	683
FRT18IDRHW0	218758400	10	15 - 16	5.00	683
FRT18INLHW0	218758400	10	15 - 16	5.00	683
FRT18IPRHW0	218758400	10	15 - 16	5.00	683
FRT18IQGHW0	218758400	10	15 - 16	5.00	683
FRT18JRGW1	218758400	10	15 - 16	5.00	683
FRT18KRGW1	218758400	10	15 - 16	5.00	683
FRT18LBHW0	218758400	10	15 - 16	5.00	683

FRIGIDAIRE MODELS					
Model	Service Data Sheets		Schematic Page #'s	R-134a Refrigerant Charge	Energy Efficiency Rating (kwh/yr)
	Number	Page			
FRT18LRHW0	218758400	10	15 - 16	5.00	683
FRT18NNGW1	218758400	10	15 - 16	5.00	683
FRT18NNHW0	218758400	10	15 - 16	5.00	683
FRT18NRGW1	218758400	10	15 - 16	5.00	683
FRT18NRHW0	218758400	10	15 - 16	5.00	683
FRT18PCGW1	218758400	10	15 - 16	5.00	683
FRT18PRGW1	218758400	10	15 - 16	5.00	683
FRT18PRHW0	218758400	10	15 - 16	5.00	683
FRT18QBGW1	218758400	10	15 - 16	5.00	683
FRT18QGF3	218758400	10	15 - 16	5.00	683
FRT18QGHW0	218758400	10	15 - 16	5.00	683
FRT18QRCW6	218758400	10	15 - 16	5.00	683
FRT18QRHW0	218758400	10	15 - 16	5.00	683
FRT18QRHW1	218758400	10	15 - 16	5.00	683
FRT18QRHW2	218758400	10	15 - 16	5.00	683
FRT18SJGW2	218758400	10	15 - 16	5.00	683
FRT18TGF1	218758400	10	15 - 16	5.00	683
FRT18TNGW1	218758400	10	15 - 16	5.00	683
FRT18TRCW7	218758400	10	15 - 16	5.00	683
FRT20NGCW9	218771500	12	19 - 20	4.50	732
FRT20NGCWA	218771500	12	19 - 20	4.50	732
FRT21NRGW1	218755000	9	15 - 16	5.50	741
FRT21NRGW2	218755000	9	15 - 16	5.50	741
FRT21NSGW1	218755000	9	15 - 16	5.50	741
FRT21NSGW2	218755000	9	15 - 16	5.50	741

FRIGIDAIRE MODELS					
Model	Service Data Sheets		Schematic Page #'s	R-134a Refrigerant Charge	Energy Efficiency Rating (kwh/yr)
	Number	Page			
FRT21PRGW1	218755000	9	15 - 16	5.50	741
FRT21PRGW2	218755000	9	15 - 16	5.50	741
FRT21PRGW3	218755000	9	15 - 16	5.50	741
FRT21PRHW1	218755000	9	15 - 16	5.50	741
FRT21PRHW2	218755000	9	15 - 16	5.50	741
FRT21PRHW3	218755000	9	15 - 16	5.50	741
FRT21TNGW1	218755000	9	15 - 16	5.50	741
FRT21TNGW2	218755000	9	15 - 16	5.50	741
FRT21TNGW3	218755000	9	15 - 16	5.50	741
FRT21TSGW1	218755000	9	15 - 16	5.50	741
FRT21TSGW2	218755000	9	15 - 16	5.50	741
FRT22INLHW0	218901900	14	17 - 18	4.50	740
FRT22QRGW2	218771400	11	17 - 18	4.50	740
FRT22QRGW3	218901900	14	17 - 18	4.50	740
FRT22RGCW8	218771600	12	21 - 22	4.50	740
FRT22RGCW9	218771600	12	21 - 22	4.50	740
FRT22RGCWA	218771600	12	21 - 22	4.50	740
FRT22RGCWB	218901800	13	21 - 22	4.50	740
FRT22RGHW0	218901800	13	21 - 22	4.50	740
FRT22RRHW0	218901900	14	17 - 18	4.50	740
TAPPAN MODELS					
TRT16NRHW0	218755000	9	15 - 16	3.75	639
TRT18GREW5	218758400	10	15 - 16	5.00	683
TRT18NRHW0	218758400	10	15 - 16	5.00	683

UNIVERSAL / MULTIFLEX MODELS					
Model	Service Data Sheets		Schematic Page #'s	R-134a Refrigerant Charge	Energy Efficiency Rating (kwh/yr)
	Number	Page			
MRT13BSCW5	218758400	10	15 - 16	3.75	586
MRT13CREW5	218758400	10	15 - 16	3.75	586
MRT15CNEW7	218758400	10	15 - 16	5.00	639
MRT15CNEW9	218758400	10	15 - 16	5.00	639
MRT15CPEW6	218755000	9	15 - 16	3.75	639
MRT15CPEW8	218755000	9	15 - 16	3.75	639
MRT15CSEW7	218758400	10	15 - 16	5.00	639
MRT15CSEW9	218758400	10	15 - 16	5.00	639
MRT15CSEWB	218755000	9	15 - 16	3.75	639
MRT15FNGW5	218758400	10	15 - 16	5.00	639
MRT16CGEW6	218755000	9	15 - 16	3.75	639
MRT16CGEW8	218755000	9	15 - 16	3.75	639
MRT16DRGW2	218755000	9	15 - 16	3.75	639
MRT16DRGW4	218755000	9	15 - 16	3.75	639
MRT16FRGW2	218755000	9	15 - 16	3.75	639
MRT18BSCW5	218758400	10	15 - 16	5.00	683
MRT18BSCW6	218758400	10	15 - 16	5.00	683
MRT18CSGW1	218758400	10	15 - 16	5.00	683
MRT18DNGW1	218758400	10	15 - 16	5.00	683
MRT18FNGW1	218758400	10	15 - 16	5.00	683
MRT18GRGW1	218758400	10	15 - 16	5.00	683
MRT18GSHW0	218758400	10	15 - 16	5.00	683
MRT18NREW4	218758400	10	15 - 16	5.00	683
MRT18PNGW1	218758400	10	15 - 16	5.00	683

UNIVERSAL / MULTIFLEX MODELS					
Model	Service Data Sheets		Schematic Page #'s	R-134a Refrigerant Charge	Energy Efficiency Rating (kwh/yr)
	Number	Page			
MRT18PNHW0	218758400	10	15 - 16	5.00	683
MRT18SJFW3	218758400	10	15 - 16	5.00	683
MRT18SJHW0	218758400	10	15 - 16	5.00	683
MRT18TRFW3	218758400	10	15 - 16	5.00	683
MRT21GNGW1	218755000	9	15 - 16	5.50	741
MRT21GNGW2	218755000	9	15 - 16	5.50	741
MRT21NREW2	218755000	9	15 - 16	5.50	741
MRT21NREW3	218755000	9	15 - 16	5.50	741
MRT21NSGW2	218755000	9	15 - 16	5.50	741
MRT21NSHW0	218755000	9	15 - 16	5.50	741
GIBSON MODELS					
GRT13CRHW0	218758400	10	15 - 16	3.75	586
GRT16CNHW0	218755000	9	15 - 16	3.75	639
GRT16CNHW1	218758400	10	15 - 16	5.00	639
GRT16CRHW3	218758400	10	15 - 16	4.50	639
GRT18DNEW4	218758400	10	15 - 16	5.00	683
GRT18DRHW0	218758400	10	15 - 16	5.00	683
GRT18ISJHW0	218758400	10	15 - 16	5.00	683
GRT18QNCW6	218758400	10	15 - 16	5.00	683
GRT18QNHW0	218758400	10	15 - 16	5.00	683
GRT18SJFW3	218758400	10	15 - 16	5.00	683
GRT18SJHW0	218758400	10	15 - 16	5.00	683
GRT21IPRHW0	218755000	9	15 - 16	5.50	741
GRT21PRCW4	218755000	9	15 - 16	5.50	741
GRT21PRCW5	218755000	9	15 - 16	5.50	741
GRT21PRHW0	218755000	9	15 - 16	5.50	741
GRT21TRCW2	218755000	9	15 - 16	5.50	741

WHITE WESTINGHOUSE MODELS					
Model	Service Data Sheets		Schematic Page #'s	R-134a Refrigerant Charge	Energy Efficiency Rating (kwh/yr)
	Number	Page			
WRT13GRHW0	218758400	10	15 - 16	3.75	586
WRT15CSHW0	218755000	9	15 - 16	3.75	639
WRT16NRHW0	218755000	9	15 - 16	3.75	639
WRT18NRHW0	218758400	10	15 - 16	5.00	683

SERVICE DATA SHEET 218755000				
PERFORMANCE DATA NO LOAD AND NO DOOR OPENINGS AT MID-POINT CONTROL SETTING				
	65°F Ambient		90°F Ambient	
Operating Time	30 to 45%		54 to 65%	
Freezer Temperature	0 to 8°F		0 to 6°F	
Refrigerator Temperature	35 to 40°F		35 to 40°F	
Low Side Pressure (Cut-In)	5 to 16 psig		5 to 16 psig	
Low Side Pressure (Cut-Out)	-2 to 2 psig		-2 to 2 psig	
High Side Pressure (Last 1/3rd of Cycle)	110 to 120 psig		150 to 175 psig	
Wattage (Last 1/3rd of Cycle)	150 to 200		150 to 200	
Amps (Running)	1.3 to 1.8		1.3 to 1.8	
Base Voltage	115 VAC		115 VAC	
DEFROST SPECIFICATIONS				
Cabinet Size	Thermostat		Heater	
	Cut In	Cut Out	Watts	Ohms
14.5' - 16.6'	25°F	47°F	400	33Ω
18' - 20.6'	25°F	47°F	475	28Ω
Defrost 21 Minutes Every 8 Hours of Compressor Run Time				
ICE MAKER SPECIFICATIONS				
Electrical	115 Volts		60 Hertz	
Thermostat	Open at 48°F		Closes at 15°F	
Heater Wattage	165			

SERVICE DATA SHEET 218758400

**PERFORMANCE DATA
NO LOAD AND NO DOOR OPENINGS AT MID-POINT CONTROL SETTING**

Type A - With Run Capacitor Type B - Without Capacitor	65°F Ambient		90°F Ambient	
	Type A	Type B	Type A	Type B
Operating Time	30 to 45%	35 to 45%	54 to 65%	55 to 67%
Freezer Temperature	0 to 8°F	0 to 6°F	0 to 6°F	0 to 6°F
Refrigerator Temperature	35 to 40°F	35 to 40°F	35 to 40°F	35 to 40°F
Low Side Pressure (Cut-In)	6 to 13	6 to 9	6 to 13	6 to 13
Low Side Pressure (Cut-Out)	-2 to 2	-2 to 2	-2 to 3	-2 to 2
High Side Pressure (Last 1/3rd of Cycle)	105 to 115	105 to 115	160 to 185	160 to 185
Wattage (Last 1/3rd of Cycle)	150 to 200	190 to 220	150 to 200	190 to 220
Amps (Running)	1.3 to 1.8	2.2 to 2.6	1.3 to 1.8	2.2 to 2.6
Base Voltage	115 VAC	115 VAC	115 VAC	115 VAC

DEFROST SPECIFICATIONS

Cabinet Size	Thermostat		Heater	
	Cut In	Cut Out	Watts	Ohms
13' - 17'	25°F	47°F	400	33Ω
18'	25°F	47°F	475	28Ω

Defrost 21 Minutes Every 8 Hours of Compressor Run Time

ICE MAKER SPECIFICATIONS

Electrical	115 Volts	60 Hertz
Thermostat	Opens at 48°F	Closes at 15°F
Heater Wattage	165	

SERVICE DATA SHEET 218771400				
PERFORMANCE DATA NO LOAD AND NO DOOR OPENINGS AT MID-POINT CONTROL SETTING				
	65°F Ambient		90°F Ambient	
Operating Time	25 to 35%		45 to 55%	
Freezer Temperature	2 to 8°F		0 to 5°F	
Refrigerator Temperature	35 to 40°F		35 to 40°F	
Low Side Pressure (Cut-In)	8 to 16 psig		8 to 16 psig	
Low Side Pressure (Cut-Out)	1 to 4 psig		1 to 4 psig	
High Side Pressure (Last 1/3rd of Cycle)	110 to 120 psig		150 to 175 psig	
Wattage (Last 1/3rd of Cycle)	150 to 200		150 to 200	
Amps (Running)	1.3 to 1.8		1.3 to 1.8	
Base Voltage	115 VAC		115 VAC	
DEFROST SPECIFICATIONS				
Cabinet Size	Thermostat		Heater	
	Cut In	Cut Out	Watts	Ohms
20' - 22'	25°F	47°F	475	28Ω
24' - 26'	25°F	47°F	550	24Ω
Defrost 21 Minutes Every 8 Hours of Compressor Run Time				
CONDENSER FAN MOTOR				
Watts	RPM		Amps	
2.3	1300 CW Opposite Shaft		.15 Running	
THERMOSTATIC DAMPER				
	Full Open		Closed	
	33°F +/- 2°F		22°F +/- 2°F	
ICE MAKER SPECIFICATIONS				
Electrical	115 Volts		60 Hertz	
Thermostat	Opens at 48°F		Closes at 15°F	
Heater Wattage	165			

SERVICE DATA SHEET 218771500 AND 218771600

**PERFORMANCE DATA
NO LOAD AND NO DOOR OPENINGS AT MID-POINT CONTROL SETTING**

	65°F Ambient	90°F Ambient
Operating Time	25 to 35%	45 to 55%
Freezer Temperature	2 to 8°F	0 to 5°F
Refrigerator Temperature	35 to 40°F	35 to 40°F
Low Side Pressure (Cut-In)	8 to 16 psig	8 to 16 psig
Low Side Pressure (Cut-Out)	1 to 4 psig	1 to 6 psig
High Side Pressure (Last 1/3rd of Cycle)	110 to 120 psig	150 to 175 psig
Wattage (Last 1/3rd of Cycle)	150 to 200	150 to 200
Amps (Running)	1.3 to 1.8	1.3 to 1.8
Base Voltage	115 VAC	115 VAC

DEFROST SPECIFICATIONS

Cabinet Size	Thermostat		Heater	
	Cut In	Cut Out	Watts	Ohms
20' - 22'	25°F	47°F	475	28Ω
24' - 26'	25°F	47°F	550	24Ω

Defrost 21 Minutes Every 8 Hours of Compressor Run Time

CONDENSER FAN MOTOR

Watts	RPM	Amps
2.3	1300 CW Opposite Shaft	.15 Running

THERMOSTATIC DAMPER

	Full Open	Closed
	33°F +/- 2°F	22°F +/- 2°F

ICE MAKER SPECIFICATIONS

Electrical	115 Volts	60 Hertz
Thermostat	Opens at 48°F	Closes at 15°F
Heater Wattage	165	

SERVICE DATA SHEET 218901800				
PERFORMANCE DATA NO LOAD AND NO DOOR OPENINGS AT MID-POINT CONTROL SETTING				
Type A With Run/Start Capacitor	65°F Ambient		90°F Ambient	
Operating Time	25 to 35%		45 to 55%	
Freezer Temperature	2 to 8°F		0 to 5°F	
Refrigerator Temperature	35 to 40°F		35 to 40°F	
Low Side Pressure (Cut-In)	8 to 16 psig		8 to 16 psig	
Low Side Pressure (Cut-Out)	1 to 4 psig		1 to 6 psig	
High Side Pressure (Last 1/3rd of Cycle)	110 to 120 psig		150 to 175 psig	
Wattage (Last 1/3rd of Cycle)	150 to 200		150 to 200	
Amps (Running)	1.3 to 1.8		1.3 to 1.8	
Base Voltage	115 VAC		115 VAC	
DEFROST SPECIFICATIONS				
Cabinet Size	Thermostat		Heater	
	Cut In	Cut Out	Watts	Ohms
20' - 22'	25°F	47°F	475	28Ω
24' - 26'	25°F	47°F	550	24Ω
Defrost 21 Minutes Every 8 Hours of Compressor Run Time				
CONDENSER FAN MOTOR				
Watts	RPM		Amps	
2.3	1300 CW Opposite Shaft		.15 Running	
THERMOSTATIC DAMPER				
	Full Open		Closed	
ICE MAKER SPECIFICATIONS				
Electrical	115 Volts		60 Hertz	
Thermostat	Open 48° F		Close 15° F	
Heater Wattage	165			

SERVICE DATA SHEET 218901900				
PERFORMANCE DATA NO LOAD AND NO DOOR OPENINGS AT MID-POINT CONTROL SETTING				
Type A With Run/Start Capacitor	65°F Ambient		90°F Ambient	
Operating Time	25 to 35%		45 to 55%	
Freezer Temperature	2 to 8°F		0 to 5°F	
Refrigerator Temperature	35 to 40°F		35 to 40°F	
Low Side Pressure (Cut-In)	8 to 16 psig		8 to 16 psig	
Low Side Pressure (Cut-Out)	1 to 4 psig		1 to 4 psig	
High Side Pressure (Last 1/3rd of Cycle)	110 to 120 psig		150 to 175 psig	
Wattage (Last 1/3rd of Cycle)	150 to 200		150 to 200	
Amps (Running)	1.3 to 1.8		1.3 to 1.8	
Base Voltage	115 VAC		115 VAC	
DEFROST SPECIFICATIONS				
Cabinet Size	Thermostat		Heater	
	Cut In	Cut Out	Watts	Ohms
20' - 22'	25°F	47°F	475	28Ω
24' - 26'	25°F	47°F	550	24Ω
Defrost 21 Minutes Every 8 Hours of Compressor Run Time				
CONDENSER FAN MOTOR				
Watts	RPM		Amps	
2.3	1,300 CW Opposite Shaft		.15 Running	
THERMOSTATIC DAMPER				
	Full Open		Closed	
ICE MAKER SPECIFICATION				
Electrical	115 Volts		60HZ.	
Thermostat	Open 48° F		Close 15° F	
Heater Wattage	165			

**WIRING DIAGRAMS FOR SERVICE DATA SHEETS
218755000 AND 218758400**

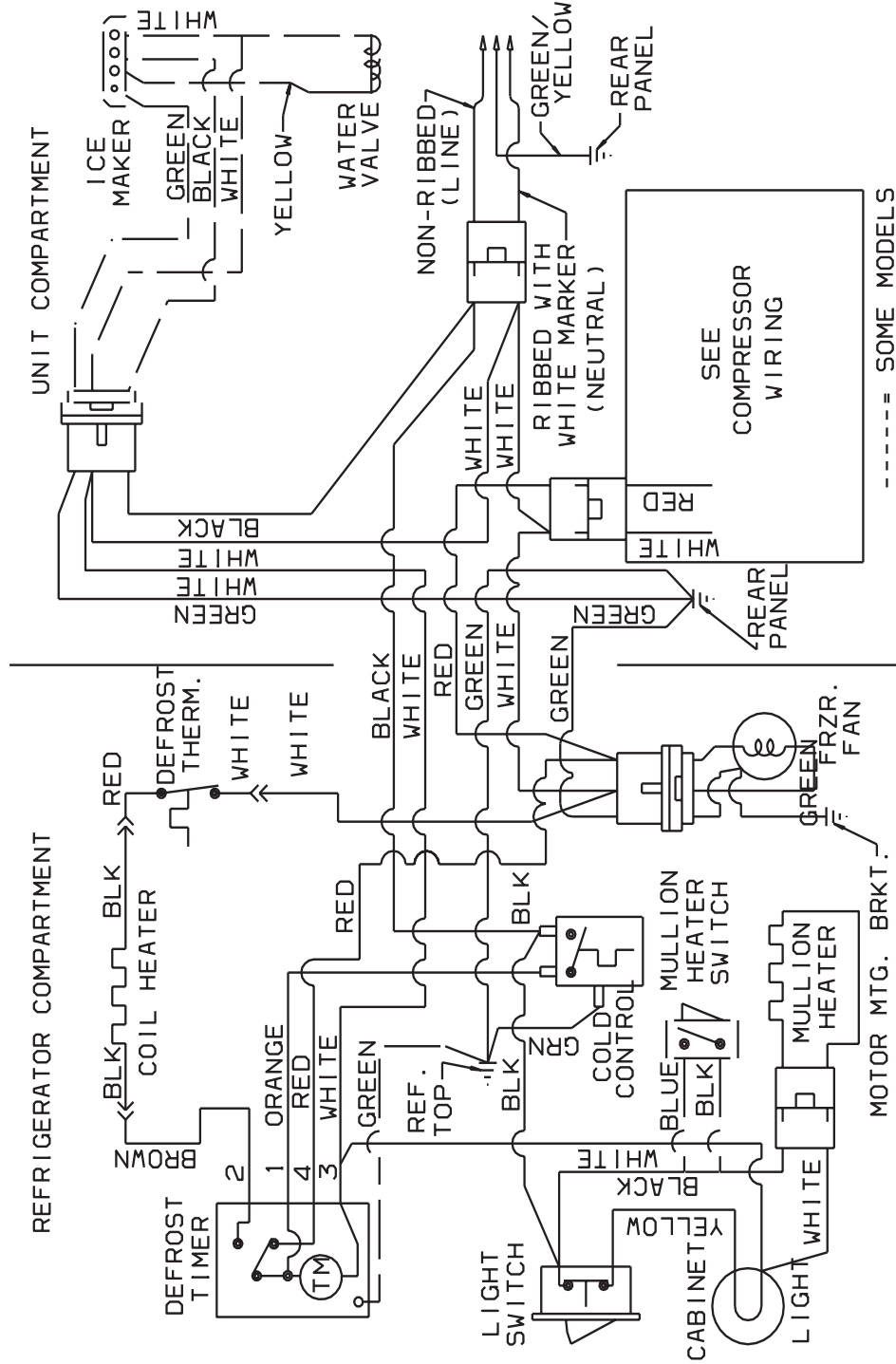

Wiring Diagram # 193832C

WIRING DIAGRAMS FOR SERVICE DATA SHEETS 218755000 AND 218758400 (Cont.)

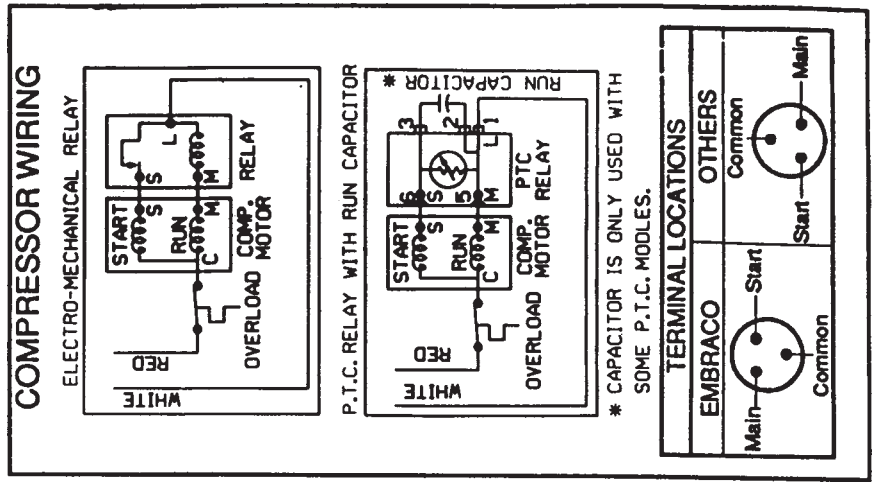
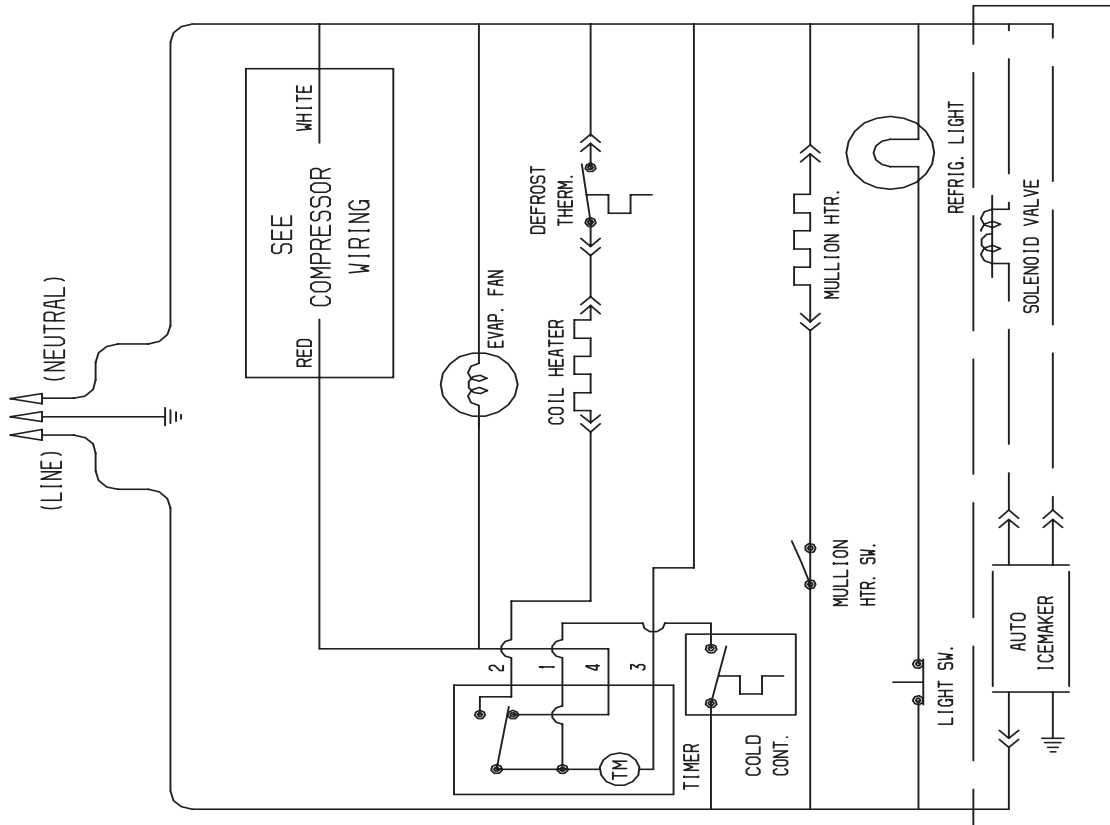

WIRING DIAGRAMS FOR SERVICE DATA SHEET 218771400 AND 218901900

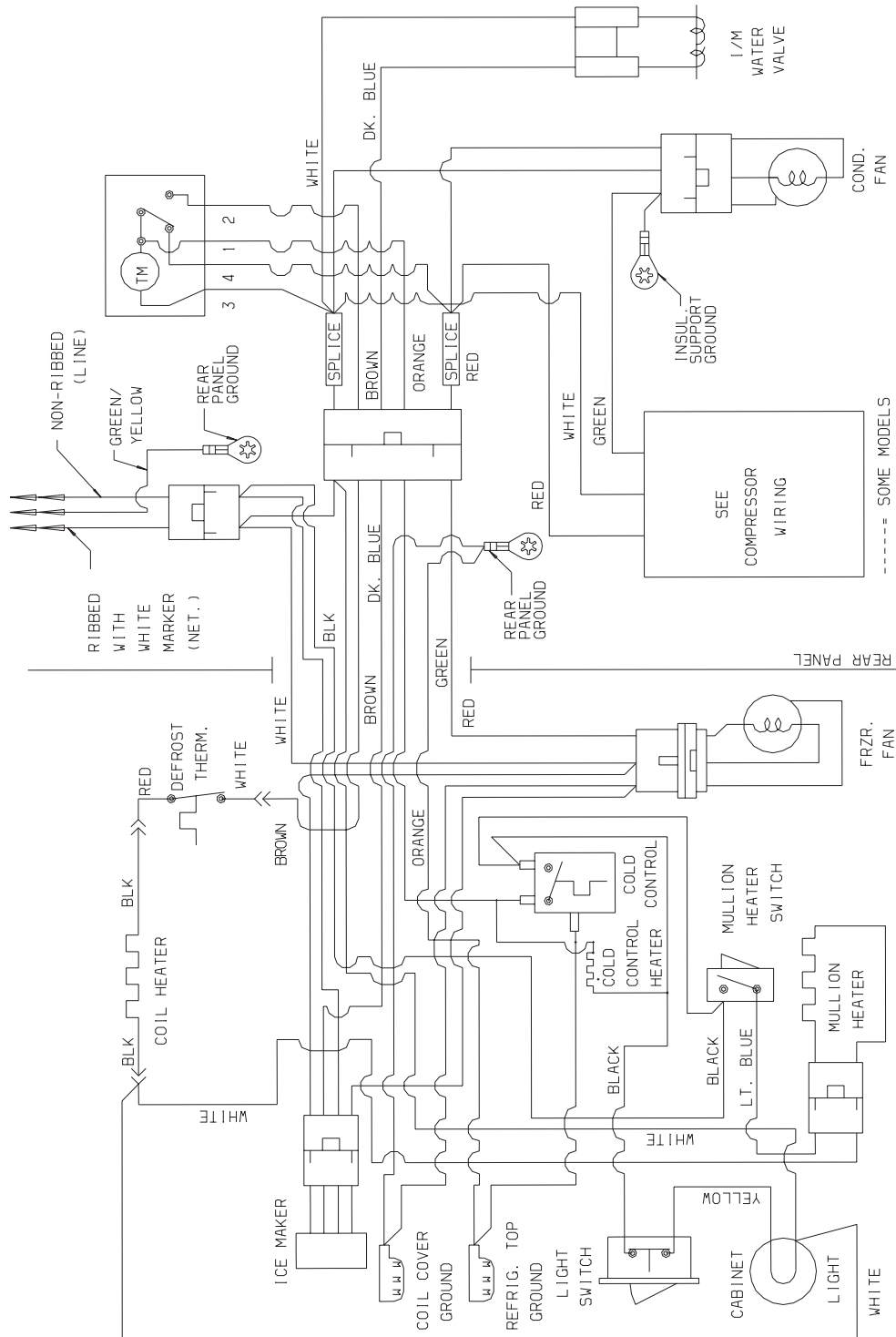

Wiring Diagram # 2186635

WIRING DIAGRAMS FOR SERVICE DATA SHEET 218771400 AND 218901900 (Cont.)

COMPRESSOR WIRING

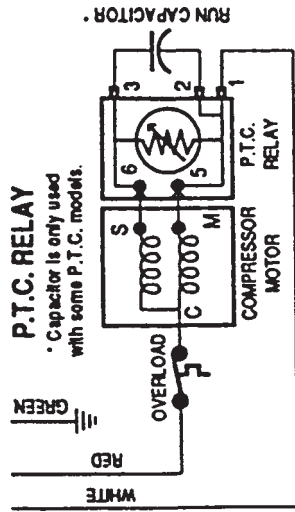

COMPRESSOR TERMINAL LOCATION

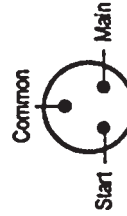

LADDER SCHEMATIC

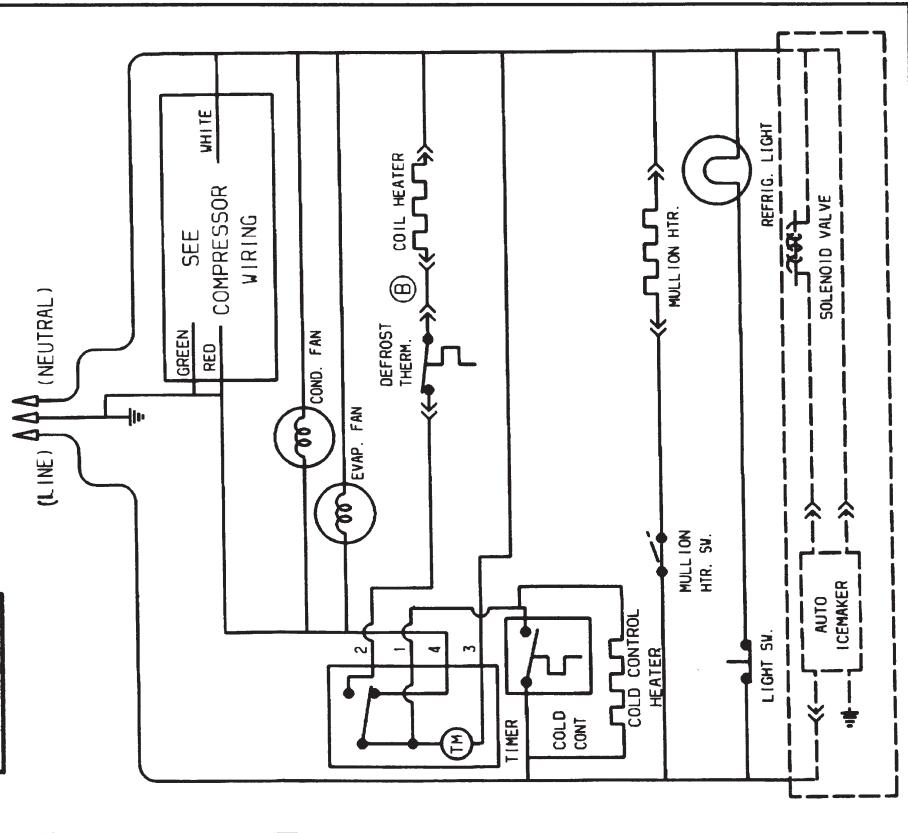

WIRING DIAGRAMS FOR SERVICE DATA SHEET 218771500.

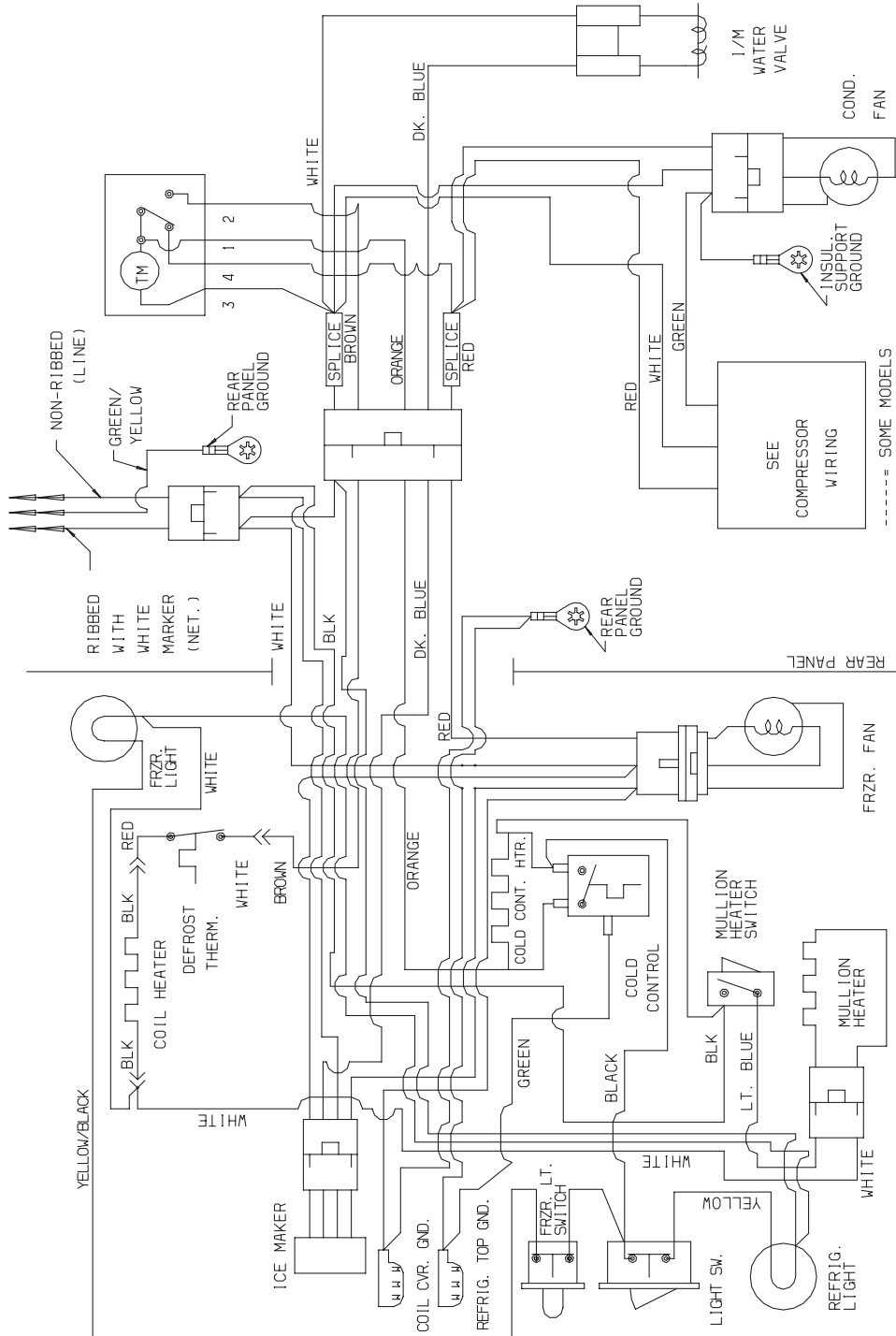

Wiring Diagram # 2186765

WIRING DIAGRAMS FOR SERVICE DATA SHEET 218771500. (Cont.)

SCHEMATIC

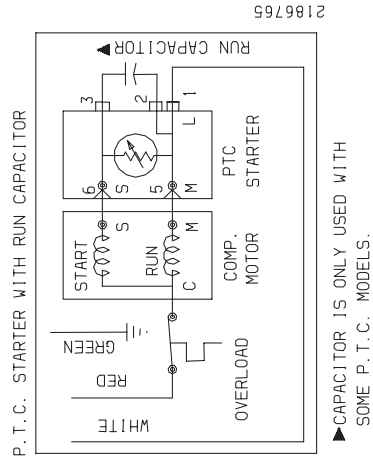
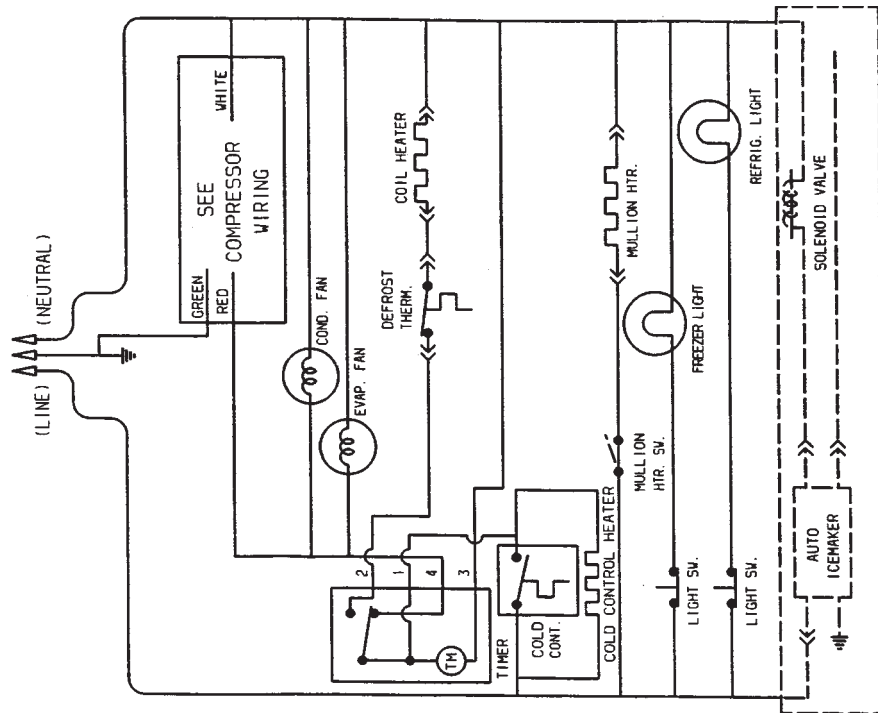

WIRING DIAGRAMS FOR SERVICE DATA SHEETS 218771600 AND 218901800.

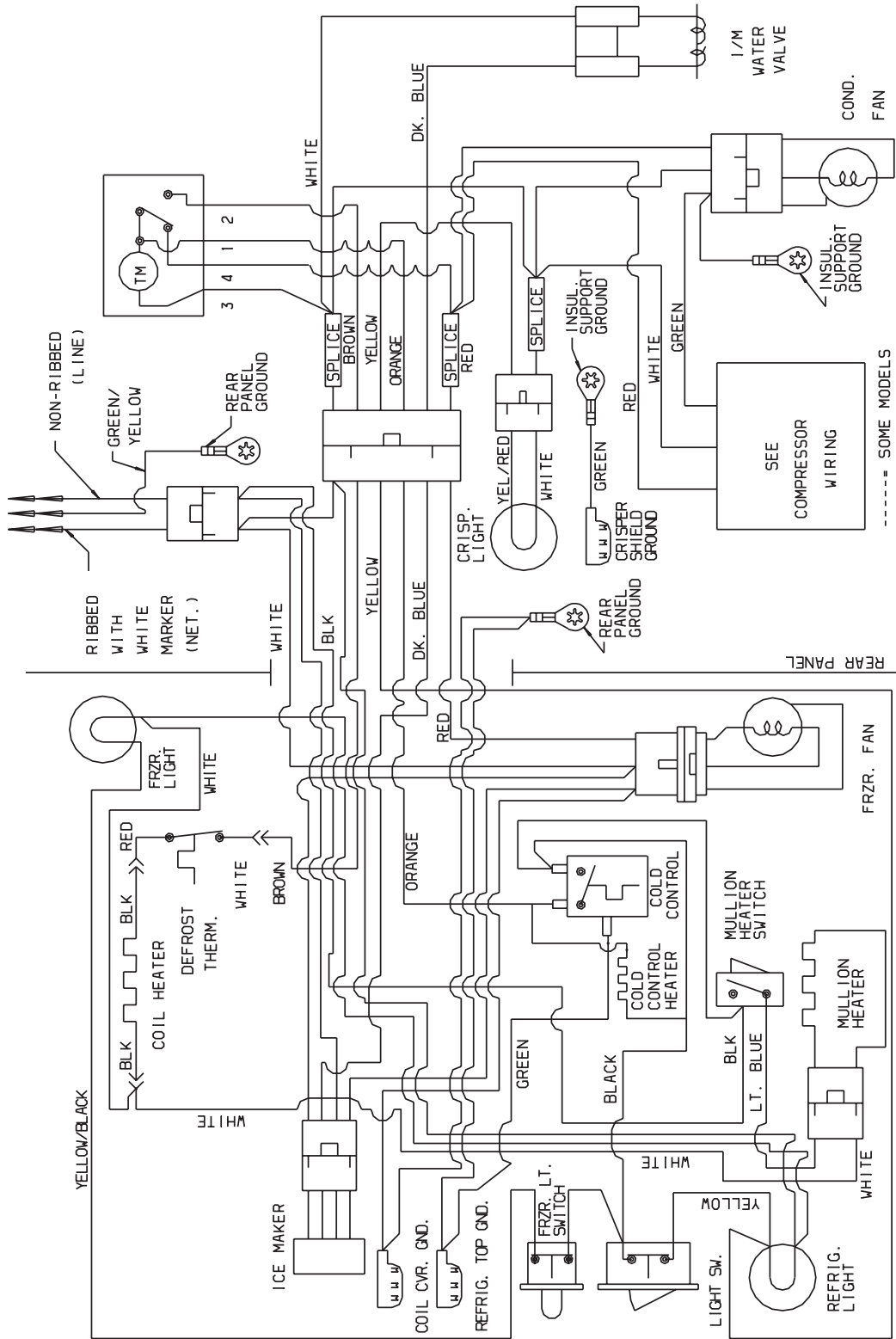

Wiring Diagram # 2186719

WIRING DIAGRAMS FOR SERVICE DATA SHEET 218771600 AND 218901800 (Cont.)

SCHEMATIC

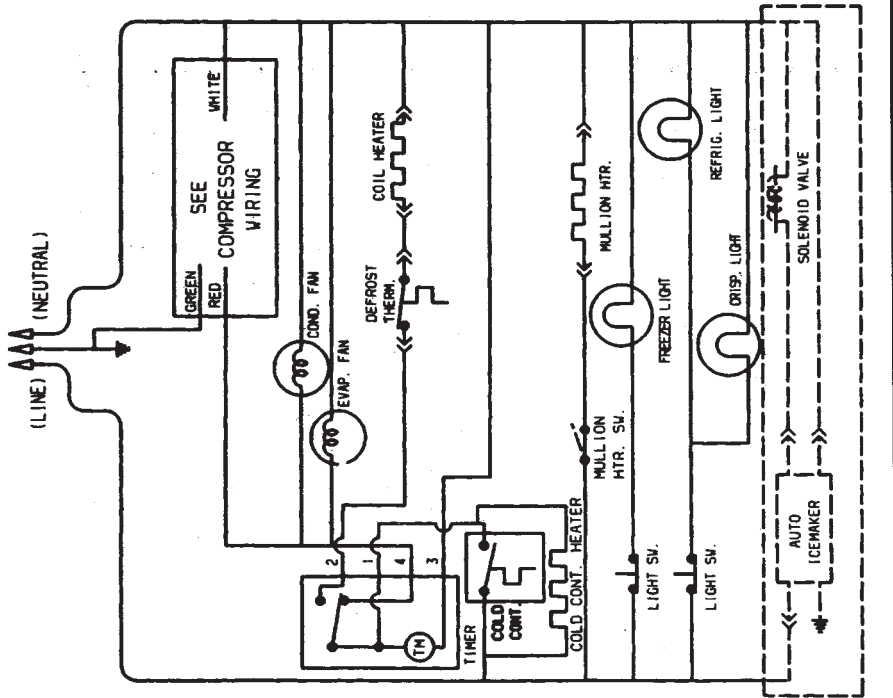

COMPRESSOR WIRING

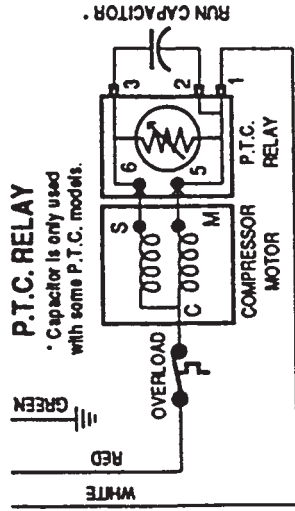

COMPRESSOR TERMINAL LOCATION

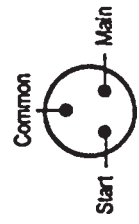

WIRING DIAGRAMS FOR ICEMAKERS. *(Some Models)*

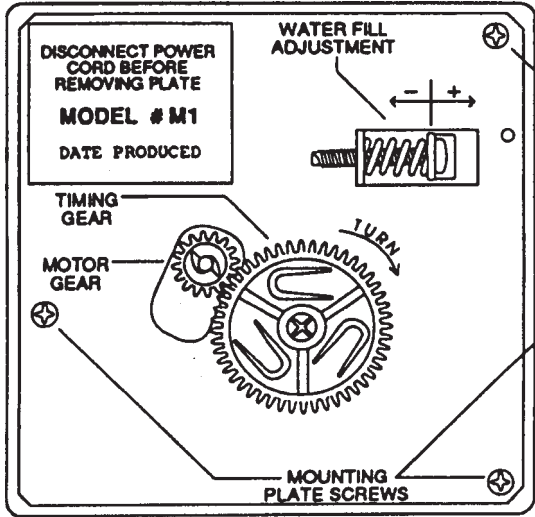

ICE MAKER INFORMATION

Test Cycling

Remove cover by inserting screwdriver in notch at bottom and prying cover from housing. Use screwdriver to rotate motor gear counterclockwise until holding-switch circuit is completed. All components of ice maker should function to complete the cycle.

Water Fill Volume

The water fill adjustment screw will change the fill time. One full turn is equal to 20cc (.68 oz). The correct fill is 90 to 120cc (3.0 to 4.0 oz). When a water valve is replaced the fill volume must be checked.

WIRING DIAGRAM

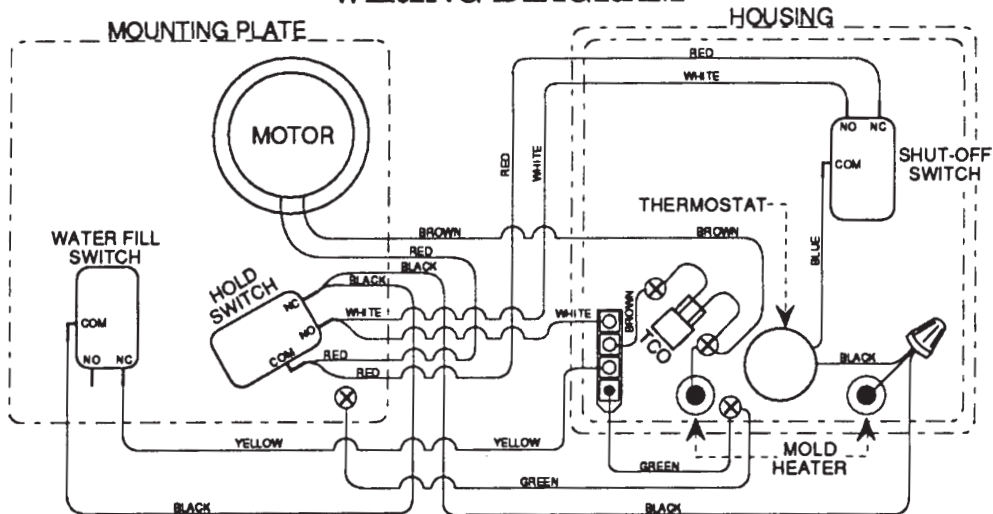

SCHEMATIC

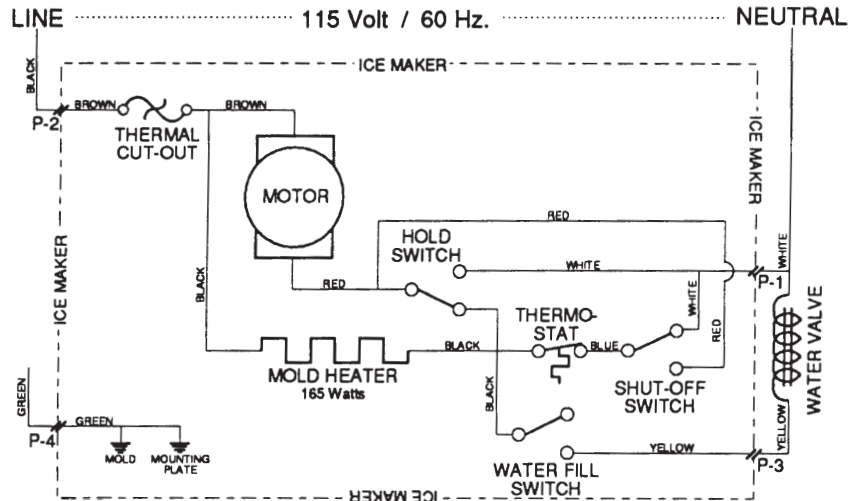

TROUBLESHOOTING GUIDE

PROBLEM	CAUSE	REMEDY
Compressor will not run.	No voltage at wall receptacle.	Check circuit breaker, fuse, or ground fault circuit interuptions.
	Service cord defective, or unplugged at wall receptacle.	Check cord.
	Low voltage causing compressor to cycle on overload.	Voltage fluctuation should not exceed +/- 10% of 115VAC. (104 - 127 VAC)
	Control thermostat knob in OFF position.	Turn control thermostat knob to ON position.
	Inoperative control thermostat.	Replace control thermostat.
	Compressor stuck.	Replace compressor.
	Compressor windings open.	Replace compressor.
	Defrost timer stuck in defrost mode.	Replace defrost timer.
	Compressor overload stuck open.	Replace compressor overload.
	Relay lead loose.	Repair or replace lead.
	Relay loose or inoperative.	Replace relay.
	Service cord pulled out of harness.	Repair connection.
	Faulty cabinet wiring.	Repair wiring.
	Compressor runs but does not cool.	System out of refrigerant.
Compressor not pumping.		Replace compressor. *
Restricted filter drier.		Replace filter drier. *
Restricted capillary tube.		Replace heat exchanger and evaporator assembly. *
Moisture in system.		See NOTE. *

- * NOTE:**
- Repair or replace component that is leaking.
 - Replace the compressor if the system is contaminated.
 - Blow out remaining part of system with dry Nitrogen.
 - Pump down and recharge per listing on product serial plate.
 - Always replace filter drier when repairing sealed system.

PROBLEM	CAUSE	REMEDY
Compressor short cycles.	Erratic control thermostat.	Replace control thermostat.
	Faulty relay.	Replace relay.
	Restricted air flow over condenser.	Ensure unobstructed air flow over condenser.
	Low voltage. Fluctuation exceeds +/- 10% of nominal rating.	Call qualified electrician.
	Compressor draws excessive wattage.	Replace compressor.
Compressor runs too much.	Control thermostat is erratic, or not properly set.	Replace control thermostat or re-set to normal position.
	Refrigerator exposed to unusual heat. (110° or higher)	Move refrigerator to cooler location.
	High room temperature. (110° or higher)	Advise customer not to install refrigerator where temperature will rise above 110°F because compressor will not maintain proper temperature.
	Low pumping capacity compressor.	Replace compressor.
	Door gaskets not sealing.	Adjust doors or replace door gasket.
	System undercharged.	Check for leaks. *
	System overcharged.	Charge per listing on product serial plate. *
	Interior light stays on.	Check door switch and door adjustment.
	Contaminents in system.	Flush out system. Replace filter drier, evacuate and recharge. *
	Capillary tube kinked or partially restricted.	Replace heat exchanger and evaporator assembly. *
	Filter drier partially restricted.	Replace filter drier. *
	Refrigerator and/or freezer compartment overloaded; poor air circulation.	Advise customer.
	Restricted air flow over condenser.	Ensure unobstructed air flow over condenser.
	Condenser fan motor is inoperative. (forced air condenser models only)	Replace condenser fan motor.

* See NOTE at bottom of page 24.

PROBLEM	CAUSE	REMEDY
---------	-------	--------

Noisy	Tubing vibrates.	Adjust tubing.
	Internal compressor noise.	Replace compressor.
	Loose parts.	Check shelving.
	Compressor operating at high head pressure due to restricted air flow over condenser.	Ensure unobstructed air flow over condenser.

Freezer compartment too warm.	Inoperative evaporator fan motor.	Check wiring and evaporator fan motor.
-------------------------------	-----------------------------------	--

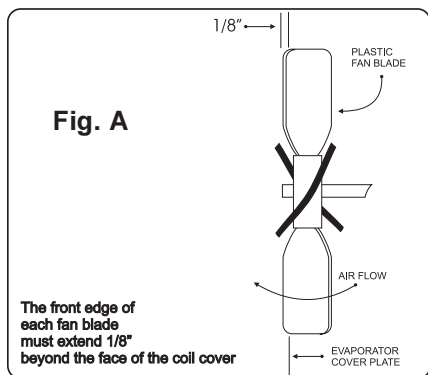

Improperly positioned fan blade.	Position fan blade properly. See Fig. A.
----------------------------------	--

Evaporator frosted up.	Check defrost system, door adjustment, and door gasket.
------------------------	---

Inoperative condenser fan motor. (forced air condenser models only)	Replace condenser fan motor.
---	------------------------------

Restricted air flow over condenser.	Clean condenser.
-------------------------------------	------------------

Freezer compartment overloaded; poor air circulation.	Advise customer.
---	------------------

Low room temperatures. (60° or lower)	Advise customer not to install refrigerator where temperature will drop below 60° F. Compressor will not maintain proper temperature.
---------------------------------------	---

Freezer or refrigerator compartment doors left open.	Advise customer.
--	------------------

Control thermostat out of calibration.	Replace control thermostat.
--	-----------------------------

Door gaskets not sealing.	Adjust or replace necessary parts.
---------------------------	------------------------------------

Control thermostat capillary tube improperly positioned.	Reposition sensing element.
--	-----------------------------

Shortage of refrigerant.	Check for leaks. *
--------------------------	--------------------

Restricted filter drier or capillary tube.	Check for leaks or burnt compressor windings. *
--	---

Freezer compartment too cold.	Inoperative cold control.	Replace cold control.
-------------------------------	---------------------------	-----------------------

Freezer compartment inlet air duct is loose or restricted. Door loose.	Reinstall air duct or remove obstruction from inlet air duct. Adjust door.
--	--

Food compartment air return duct blocked.	If foam block is frozen, replace block; if duct is blocked, remove obstruction.
---	---

Diffuser(foam block) in top of food compartment is blocked.	Replace diffuser.
---	-------------------

* See NOTE at bottom of page 24.

PROBLEM	CAUSE	REMEDY
Refrigerator compartment too warm.	Inoperative evaporator fan motor.	Check wiring and evaporator fan motor.
	Improperly positioned evaporator fan blade.	Position fan blade properly. See page 26, Figure A.
	Refrigerator compartment inlet air duct loose or restricted. Door loose.	Reinstall air duct or remove obstruction from air duct. Adjust door.
	Freezer compartment return air duct loose or restricted. Door loose.	Remove obstruction from air duct.
	Low room temperature. (60° or lower)	Advise customer not to install refrigerator where temperature will drop below 60° F. Compressor will not maintain proper temperature.
	Damper control out of calibration.	Replace damper control.
	Control thermostat knob set at too warm a setting.	Set control knob to a colder position.
	Evaporator frosted up.	Check defrost system, door adjustment, and door gaskets.
	Refrigerator compartment overloaded; poor air circulation.	Advise customer.
	Refrigerator compartment or freezer compartment door left open.	Advise customer.
	Inoperative or erratic refrigerator compartment and/or freezer compartment door switch.	Replace door switch.
	Shortage of refrigerant.	Check for leaks. *
	Restricted capillary tube or filter drier.	Check for leaks or burnt compressor windings. *
Refrigerator compartment too cold.	Inoperative cold control.	Replace cold control.
	Refrigerator compartment inlet air duct loose or restricted. Door is loose.	Re-install air duct or remove obstruction from air duct. Adjust door.
	Diffuser (foam block) in top of food compartment is broken.	Replace diffuser.

* See NOTE at bottom of page 24.

PROBLEM	CAUSE	REMEDY
Evaporator blocked with ice.	Inoperative defrost timer.	Check wiring. Repair or replace defrost timer.
	Defrost thermostat terminates too early.	Check for correct positioning of defrost thermostat. Repair or replace.
	Freezer or refrigerator compartment doors left open.	Advise customer.
	Heat exchanger and wiring harness entrance hole not sealed.	Seal entrance hole with Permagum or (Food Safe) RTV.
	Ice Maker water line and wiring harness openings not sealed.	Seal water line and wiring harness openings.
	Door seals not sealing.	Replace seals and/or adjust doors.
Frozen drain.	Drain trough not properly formed.	Ensure drain trough is at 90° angle to back of freezer and that lip is up on front and ends.
	Divider (foam block) frozen.	Replace divider. Check drain trough.

* See NOTE at bottom of page 24.



PO Box 212378 Augusta, GA 30917