

All about

Servicing

Upright Freezers

With Standard And Electronic Controls

FRIGIDAIRE™

W White-Westinghouse

Gibson

Kelvinator 

TAPPAN

Electrolux Major Appliances; North America
250 Bobby Jones Expwy
Augusta, GA 30907

This Manual has been prepared to provide Electrolux Service Personnel with Operation and Service Information for the following models.

Frigidaire Upright Freezers Equipped with the EZ Set Control:

Models FFU14F5H, FFU17F5H, FFH17F7H, FFU21F5H and FKCH17F7H

Frigidaire Upright Freezers Equipped with the Precision Set Control:

FFU14F7H, FKFH21F7H, GLFH17F8H and GLFH21F8H

Safe Servicing Practices

Avoid personal injury and/or property damage by observing important Safe Servicing Practices.

Following are some limited examples of safe practices:

1. **DO NOT** attempt a product repair if you have any doubts as to your ability to complete the repair in a safe and satisfactory manner.
2. Always Use The Correct Replacement Parts as indicated in the parts documentation. Substitutions may defeat compliance with Safety Standards Set For Home Appliances.
3. Before servicing or moving an appliance:
 - Remove power cord from the electrical outlet, trip circuit breaker to OFF position, or remove fuse.
 - Turn off water supply if unit has an icemaker.
4. Never interfere with the proper operation of any safety device.
5. **Use ONLY REPLACEMENT PARTS CATALOGED FOR THIS APPLIANCE. Substitutions may defeat compliance with Safety Standards Set For Home Appliances.**
6. **GROUNDING:** The standard color coding for safety ground wires is **GREEN**, or **GREEN** with **YELLOW STRIPES**. Ground leads are not to be used as current carrying conductors. It is **EXTREMELY** important that the service technician reestablish all safety grounds prior to completion of service. Failure to do so will create a hazard.
7. Prior to returning the product to service, ensure that:
 - All electrical connections are correct and secure.
 - All electrical leads are properly dressed and secured away from sharp edges, high temperature components, and moving parts.
 - All non-insulated electrical terminals, connectors, heaters, etc. are adequately spaced away from all metal parts and panels.
 - All safety grounds (both internal and external) are correctly and securely connected.
 - All panels are properly and securely reassembled
 - Gas and water supplies are turned ON if shut off prior to service.

ATTENTION!!!

This service manual is intended for use by persons having electrical and mechanical training and a level of knowledge of these subjects generally considered acceptable in the appliance repair trade. Electrolux Home Products, Inc. cannot be responsible, nor assume any liability, for injury or damage of any kind arising from the use of this manual.

Section 1 Basic Information

Section 1 - Basic Information 1-1

Safe Servicing Practices	1-1
Table of Contents.....	1-2
Child Safety	1-3
Model Serial Number Breakdown.....	1-4
Serial Plate	1-4
17 cu. ft. Performance and Unit Dimensions	1-5
20 cu. ft. Performance and Unit Dimensions	1-6

Section 2 - Installation Information 2-1

Important Safety Instructions	2-1
Location	2-3
Leveling.....	2-3
Electrical Information	2-4
Door Removal.....	2-5
Door Handle Mounting Instructions	2-5

Section 3 - Electronic Control 3-1

Electronic Temperature Control	3-1
Setting Selection	3-1
Control Lock	3-1
Defrost Timing	3-1
Manual Defrost	3-1
Showroom Mode	3-1
Service Diagnostic Mode.....	3-2
Initiate Service Mode.....	3-2
Error Modes.....	3-2
Thermistor Error Mode	3-2
Fail Safe Mode	3-2
Stuck Key	3-2
Thermistor Chart.....	3-2
Alarms.....	3-3
Door Ajar Alarm	3-3
High Temperature Alarm	3-3
Instructions for Programming EZ Set Controls.....	3-3
Precision Set Control	3-4
Power-up Condition.....	3-4
Setting Selection	3-4
Control Lock	3-4
Display and Temperature Scale (F°/C°)	3-4
Door Alarm.....	3-5
Extreme or Quick Freeze	3-5
High Temperature Alarm	3-5
Showroom Mode	3-5
Service Diagnostic Mode.....	3-6
Thermistor Error Mode	3-6
Fail Safe Error Mode.....	3-6
Power Loss Recovery Alarms.....	3-6

Section 4 - Refrigeration System 4-1

Definitions	4-1
Safety Warnings.....	4-1
Charging Sealed Systems.....	4-1
Soldering	4-2
Basic Components.....	4-2
Refrigerant Cycle.....	4-2
Low/High Side Leak or Undercharge.....	4-3
Testing for Refrigerant Leaks	4-3
Compressor Replacement	4-3
To Flush the System.....	4-4
To Use Dry Nitrogen to Flush the System	4-4
To Use Refrigerant to Flush the System.....	4-4
Installing a New Compressor	4-5
Condenser Replacement	4-6
Filter-Drier Installation.....	4-7
Evaporator and Suction Line Replacement	4-7
Equipment Needed for Evacuation & Recharging..	4-8
Installing Evacuation and Recharging Equipment..	4-8
Evacuating System	4-9
Charging the System	4-9
Preparing the Charging Cylinder	4-9
Final Leak Test	4-10
Verify Refrigerant Type in the System	4-11
Dedicated Equipment	4-11
R-134a Refrigeration Systems	4-11
Miscibility of R-134a and Ester Oil	4-11
Water in the Refrigeration System.....	4-12
Vacuum Pump Maintenance	4-13
Refrigerant Leaks	4-13
Leak Detection.....	4-14
R-134a Properties	4-14
HFC-134a, CFC-12 Pressure Temp. Chart.....	4-15
Inhalation Toxicity.....	4-16
Cardiac Sensitization	4-16
Spills or Leaks.....	4-16
Skin and Eye Contact	4-16
Combustibility of HFC-134a.....	4-17
Leak Testing	4-17
Bulk Delivery and Storage.....	4-17
Filling and Charging Operations.....	4-17
Refrigerant Recovery Systems.....	4-17
Thermal Decomposition	4-17

Section 5- Component Teardown 5-1

Warnings and Cautions..... 5-1
 Exterior Components..... 5-2
 Door Handle 5-2
 Kickplate..... 5-2
 Door Hinge and Door Assembly 5-2
 Lower Hinge Assembly 5-3
 Door Gasket and Inner Panel..... 5-3
 Door Lock..... 5-4
 EZ Set Control Assembly..... 5-4
 Precision Set Control Assembly 5-4
 Door Shelf Guard 5-5
 Door Switch..... 5-5
 Interior Components 5-5
 Shelf Assembly..... 5-5
 Wire Basket 5-5
 Light Shield 5-6
 Light Fixture 5-6
 Baffle Plate..... 5-6
 Evaporator Cover 5-6
 Evaporator Fan Assembly 5-7
 Defrost Thermostat..... 5-7
 Thermistor..... 5-7
 Defrost Heater 5-8
 Evaporator..... 5-8
 Compressor Area Components 5-9
 Power Cord..... 5-9
 Filter-Drier 5-9
 Drain Pan 5-9
 Compressor 5-10
 Condenser Service..... 5-11

Section 6 - Troubleshooting 6-1

Troubleshooting Chart 6-1

Section 7 - Wire Diagrams..... 7-1

Wiring Diagram 7-1

FOR YOUR SAFETY

Do not store or use gasoline, or other flammable vapors and liquids in the vicinity of this or any other appliance. Read product labels for flammability and other warnings.

CHILD SAFETY

- Destroy carton, plastic bags, and any exterior wrapping material immediately after the freezer is unpacked. Children should never use these items to play. Cartons covered with rugs, bedspreads, plastic sheets or stretch wrap may become airtight chambers, and can quickly cause suffocation.
- Remove all staples from the carton. Staples can cause severe cuts, and destroy finishes if they come in contact with other appliances or furniture.
- An empty, discarded ice box, refrigerator, or freezer is a very dangerous attraction to children.
- Remove and discard any spacers used to secure the shelves during shipping. Small objects are a choke hazard to children.
- Remove the door(s) of any appliance that is not in use, even if it is being discarded.

RISK OF CHILD ENTRAPMENT

Child entrapment and suffocation are not problems of the past. Junked or abandoned refrigerators or freezers are still dangerous – even if they will sit for “just a few days”. If you are getting rid of your old refrigerator or freezer, please follow the instructions below to help prevent accidents:

- Remove the door/lid. If your door has an electronic control panel, have it removed by a qualified technician.
- Leave shelves in place so children may not easily climb inside.
- Have the refrigerant removed by a qualified technician.

Section 1 Basic Information

Frigidaire Upright Freezer

Model Number Nomenclature

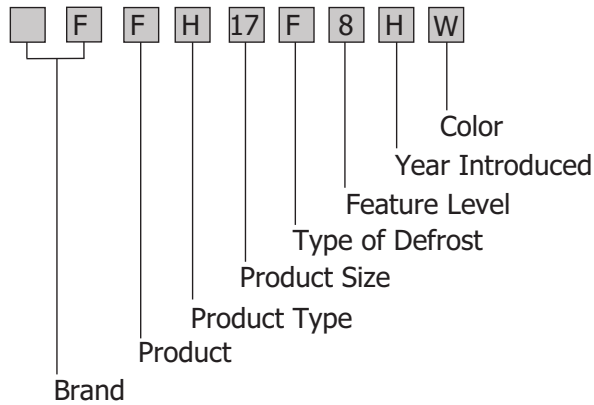

Serial Number

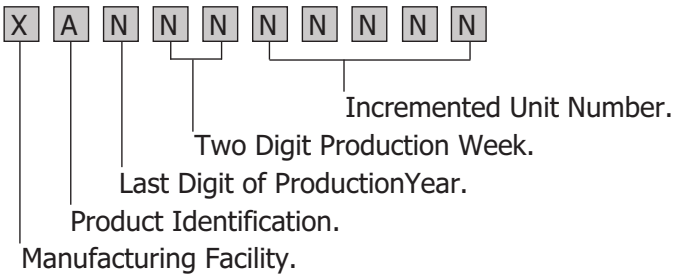

- A=Alpha
- N=Numeric
- X=Either Alpha or Numeric Character

Brand

- AF - Frigidaire Ultrafreeze
- LF - Lowe's Frigidaire
- F - Frigidaire
- GL - Frigidaire Gallery
- G - Gibson
- PL - Frigidaire Professional
- W - White Westinghouse
- FK - Kenmore Frigidaire
- K - Kelvinator

ELECTROLUX HOME PRODUCTS, INC. / AUGUSTA, GA. 30907
ELECTROLUX CANADA CORP. / NISSISSAUGA, ONT. L5V 3EA

MOD. **FFH17F8HW0**
SER. **WB00000000**

MANUFACTURED/FABRIQUE 2-08
AMPS: 5.0 A VOLTS: 115 VAC HERTZ: 60 HZ
REFRIGERANT R134A 3.5 Oz. (100 Grams)
Design Pressure/ LS/PB 140 PSIG (965 KPa)
Pression de dessin: HS/PH 320 PSIG (2206 KPa)

FREE STANDING INSTALLATION ONLY
INSTALLATION NON ENCASTREE SEULEMENT

HOUSEHOLD REFRIGERATOR
REFRIGERATEUR DOMESTIQUE
TYPE R17F

 C US
 LR67369

Energy Performance Rendement Énergétique
 VERIFIED

 EEV99421
 VÉRIFIÉ

For questions, comments, or service please call us
TOLL FREE: 1-800-944-9044

Serial Plate

The serial plate is located inside the cabinet on the left sidewall. The technician should always refer to the serial plate to assure refrigerant type and quantity, as well as electrical ratings and operating pressures.

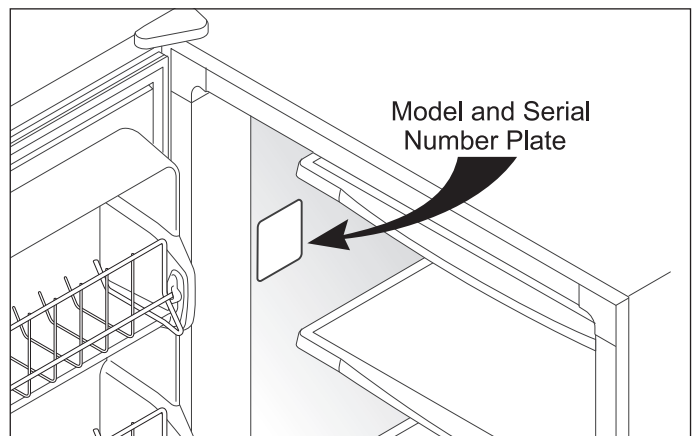

Upright Freezers with Electronic Control (EZ Set Control)

Performance

(Control at number 1 setting)

Room Ambient	70°F	90°F
Freezer Compartment Temperature.....	2 to 8°F	2 to 8°F
Percent Running Time	35 - 45%	50 - 65%
*Wattage Range (Last 1/3 of cycle)	115 - 140	140 - 155
Suction Pressure (Cut-in, cut-out), PSIG.....	14 - 0	14 - 0
High Side Pressure (Last 1/3 of cycle), PSIG.....	100 - 115	140 - 155

Model FFH17F8W Unit Dimensions

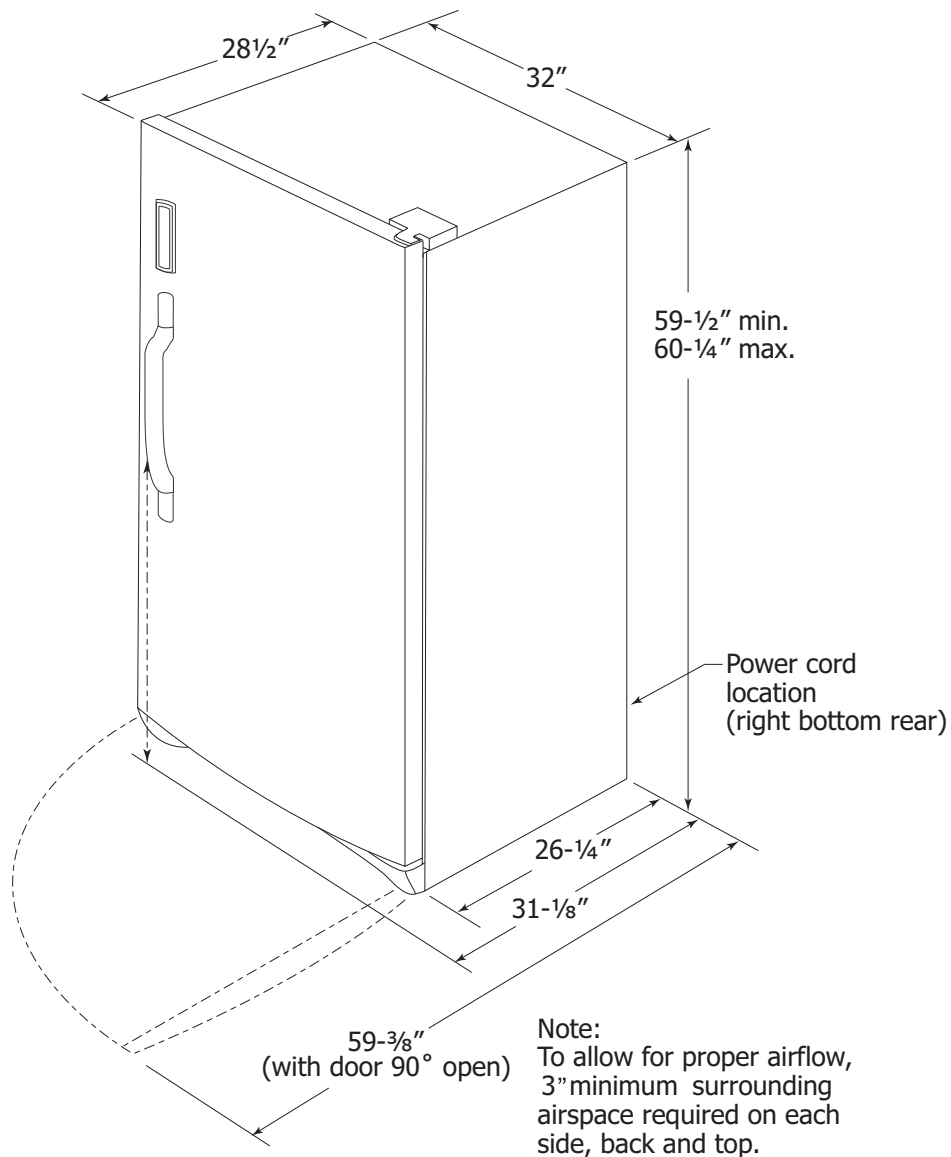

Section 1 Basic Information

Upright Freezers with Electronic Control (Precision Set Control)

Performance

Room Ambient	70°F	90°F
Freezer Compartment Temperature.....	-10 to 10°F	-10 to 10°F
Percent Running Time	30 - 45%	45 - 65%
*Wattage Range (Last 1/3 of cycle)	100 - 140	110 - 145
Suction Pressure (Cut-in, cut-out), PSIG	14 - 0	14 - 0
High Side Pressure (Last 1/3 of cycle), PSIG.....	100 - 125	140 - 165

Model GLFH21F8H Unit Dimensions

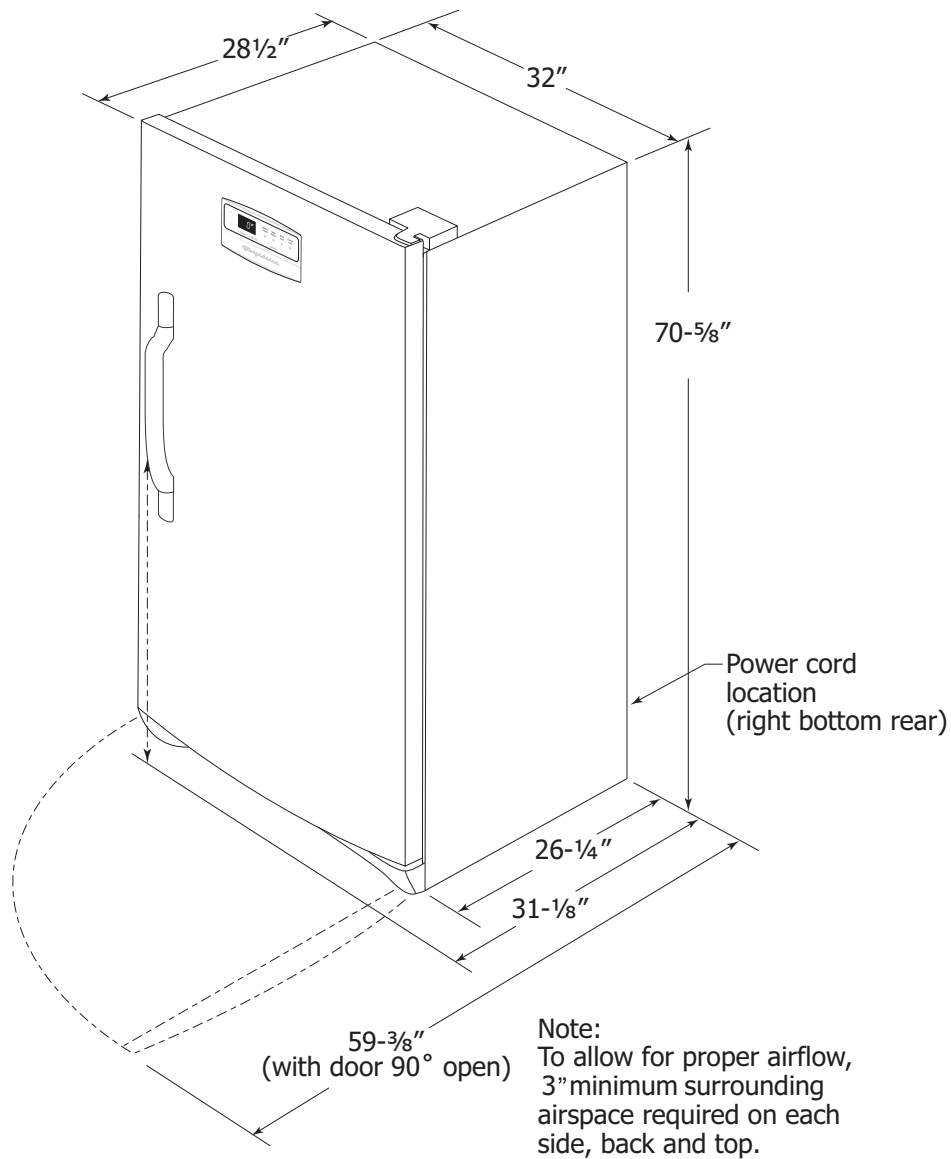

Section 2 Installation Information

Recognize safety symbols, words and labels:

Safety items throughout this manual are labeled with a WARNING or CAUTION based on the risk type as described below:



WARNING

This symbol alerts you to situations that may cause serious body harm, death or property damage.



CAUTION

This symbol alerts you to situations that may cause bodily injury or property damage.



WARNING

To reduce the risk of fire, electrical shock, or injury when using an Upright Freezer, follow basic safety precautions including the following:

- **Read all instructions before operating the freezer.**
- **Before performing any type of service or installation, make sure that electric power to the freezer is disconnected.**
- **To avoid the possibility of explosion or fire, do not store or use combustible, flammable, or explosive liquids or vapors (such as gasoline) inside or in the vicinity of this or any other appliance.**
- **This appliance is equipped with a three-prong grounding plug for protection against possible electric shock hazards. Plug it only into a dedicated, grounded electrical outlet. When only a standard two-prong electrical outlet is available, the customer must have it replaced with a dedicated, properly grounded three-prong electrical outlet before using this Appliance.**

Do not under any circumstances, cut or remove the third (ground) prong from the power cord.

Do not use an adapter plug.

Do not use an extension cord.

Do not use a power cord that is frayed or damaged.

The use of a ground fault interrupter (GFI) is not recommended.

- **Do not install or use a damaged appliance. If you receive a damaged appliance, immediately contact your dealer or builder.**
- **The installer must show the customer the location of the power plug so that they know where and how to disconnect power to the freezer.**
- **Do not install, repair, or replace any part of the freezer unless specifically recommended in the literature accompanying it. A qualified service technician should perform all other service.**



WARNING

Electrolux Home Products Inc. cannot be held responsible for damage to property or injury to persons caused by failure to comply with the installation, maintenance and safety instructions contained in this Service Manual.

Section 2 Installation Information

WARNING

Destroy carton, plastic bags, and any exterior wrapping material immediately after the refrigerator/freezer is unpacked. Children should never use these items for play. Cartons covered with rugs, bedspreads, plastic sheets or stretch wrap may become air tight chambers and can quickly cause suffocation.

A child might suffocate if he crawls into the freezer to hide or play. Remove the door/lid of the refrigerator/freezer when not in use, even if you plan to discard the freezer. Many communities have laws requiring you to take this safety precaution.

Remove or discard any spacers used to secure the shelves during shipping. Small objects are a choke hazard to children.

Child entrapment and suffocation are not problems of the past. Junked or abandoned refrigerators or freezers are still dangerous— even if they will sit for “just a few days”. If you are getting rid of your old refrigerator or freezer, please follow the instructions below to help prevent accidents:

- Remove the door/lid.
- Leave shelves in place so children may not easily climb inside.
- Have the refrigerant removed by a qualified technician.

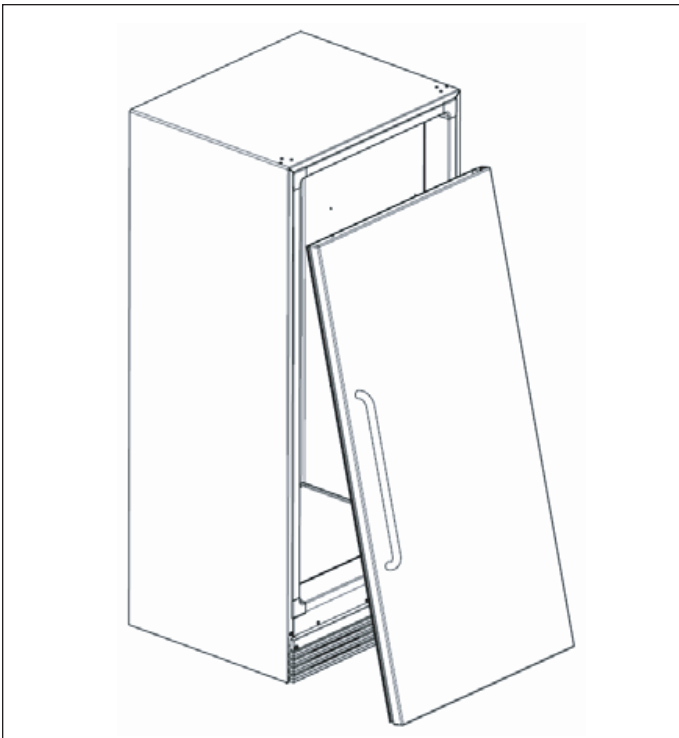

Installation Checklist

Doors

- Handles are secure and tight
- Door seals completely to cabinet on all sides
- Freezer door is level across the top

Leveling

- Freezer is level, side-to-side and tilted 1/4" (6mm) front-to-back
- Toe grille is properly attached to freezer
- Cabinet is setting solid on all corners

Electrical Power

- House power turned on
- Freezer plugged in

Final Checks

- Shipping material removed
- Freezer temperatures set
- Registration card sent in

Section 2 Installation Information

Location

1. Choose a place that is near a grounded electrical outlet. Do Not use an extension cord or an adapter plug.
2. If possible, place the freezer out of direct sunlight and away from the range, dishwasher or other heat sources.
3. The freezer must be installed on a floor that is level and strong enough to support a fully loaded freezer.
4. Consider water supply availability for models equipped with an automatic ice maker.
5. The freezer should be located where surrounding temperature will not exceed 110°F (43°C).
6. For ease of installation, proper air circulation and electrical connections, see Figure 2-1 for recommended clearances.
7. For dynamic condenser models, DO NOT block the toe grille on the lower front of your freezer. Sufficient air circulation is essential for the proper operation of your freezer.

NOTE

The exterior walls of the refrigerator/freezer may become quite warm as the compressor works to transfer heat from the inside. Temperatures as much as 30°F warmer than room temperatures can be expected.

Leveling

The freezer must have all bottom corners resting firmly on a solid floor. The floor must be strong enough to support a fully loaded freezer.

It is VERY IMPORTANT for your freezer to be level in order to function properly. If the freezer is not leveled during installation, the door/lid may be misaligned and not close or seal properly, causing cooling, frost or moisture problems.

To Level Unit:

After discarding crating screws and wood base, use a carpenter's level to level the freezer from front to back. Adjust the plastic leveling feet in front, ½ bubble higher, so that the door closes easily when left half way open.

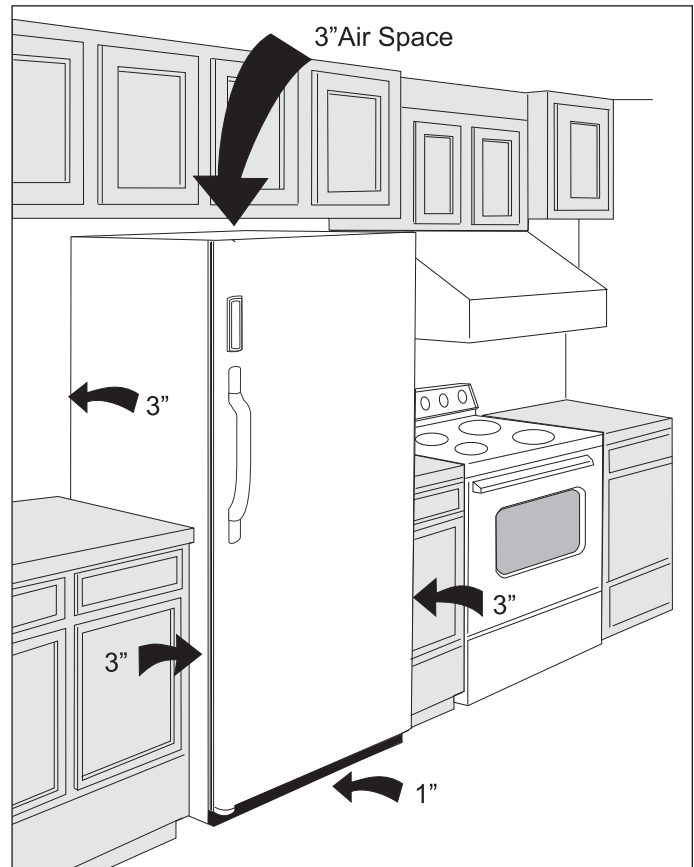

Figure 2-1. Installation Clearances

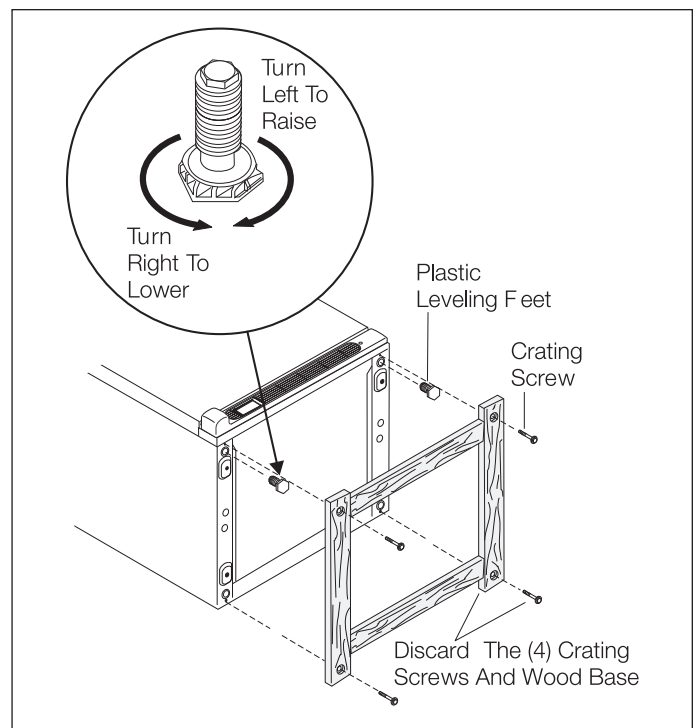

Figure 2-2. Leveling Unit

Section 2 Installation Information

Electrical Information

These guidelines must be followed to ensure that safety mechanisms in the design of this freezer will operate properly.

Refer to the serial plate for correct electrical rating. The power cord of the freezer is equipped with a three-prong grounding plug for protection against shock hazards. It must be plugged directly in to its own properly grounded three-prong receptacle, protected with a 15 amp time delay fuse or circuit breaker. The receptacle must be installed in accordance with the local codes and ordinances. Consult a qualified electrician. Receptacles with Ground Fault Circuit Interrupters (GFCI) are NOT RECOMMENDED. DO NOT USE AN EXTENSION CORD OR AN ADAPTER PLUG.

If the voltage varies by 10 percent or more, freezer performance may be affected. Operating the freezer with insufficient power can damage the motor. Such damage is not covered under the warranty. If you suspect your voltage is high or low, consult your power company for testing.

To prevent the freezer from being turned off accidentally, do not plug the unit in to an outlet controlled by a wall switch or pull cord.

Do not pinch, knot, or bend the power cord in any manner.

WARNING

Never unplug the freezer by pulling on the power cord. Always grip the plug firmly and pull straight out from the receptacle.

Turning the control to "OFF" turns off the compressor but does not disconnect power to other electrical components.

WARNING

Avoid fire hazard or electric shock. Do not use an extension cord or an adapter plug. Do not remove any prong from the power cord.

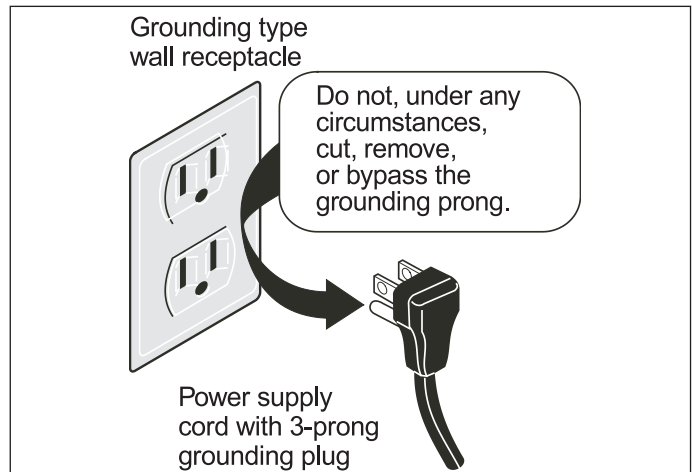

Figure 2-3. Electrical Receptacle

Section 2 Installation Information

Door Removal

For some installations it may be necessary to remove the door to fit through the entrance of the installation site.

To remove the door, follow the steps below.

1. Make sure electrical plug is disconnected from the wall outlet.
2. Gently lay freezer on its back on a soft clean surface.
3. Lift plastic cover off upper hinge assembly. (See Figure 2-4)
4. Using a T27 tamper proof Torx bit, extract screws securing the upper hinge to the unit frame.
5. Remove the grille/kickplate by extracting the screws from each end of the grille/kickplate. Remove wire from clips on bottom of cabinet. (See Figure 2-5)
6. Reach under bottom of cabinet and disconnect wire leads of door connector from the cabinet connector.
7. Using a T27 tamper proof Torx bit, extract screws securing the lower hinge to the unit frame. Use a phillips head screwdriver to extract the remaining screw from the lower hinge assembly.
8. Lift the door assembly off of the unit frame.

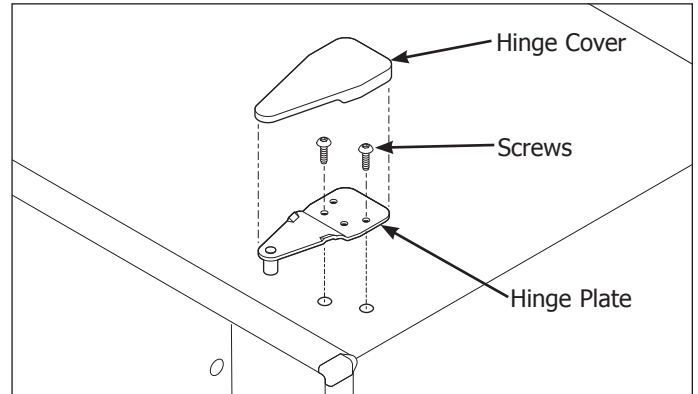

Figure 2-4. Top Hinge Removal

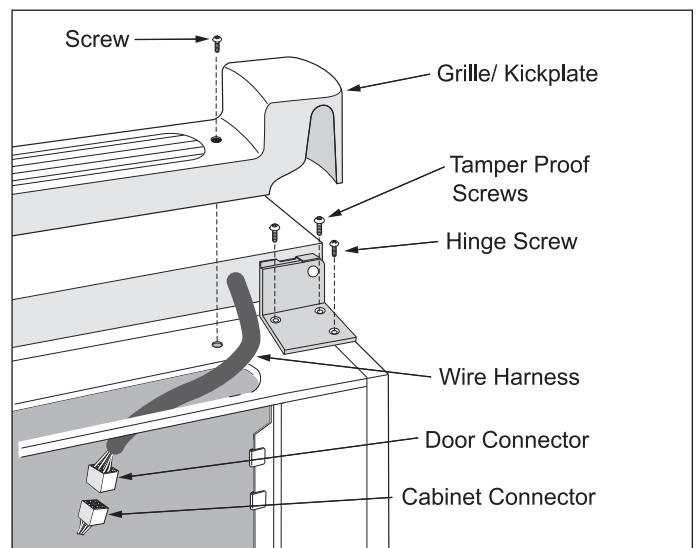

Figure 2-5. Bottom Hinge Removal

Door Handle Mounting Instructions

For some installations the door handle may need to be removed. (See Figure 2-6)

To remove the door handle:

1. Remove screw cover plates by pushing in and sliding the screw cover plate off of the door handle.
2. Using a phillips head screwdriver, extract the screws securing the door handle to the door assembly.
3. Push upwards until the screw button assembly is free of the dovetail inside the handle assembly.

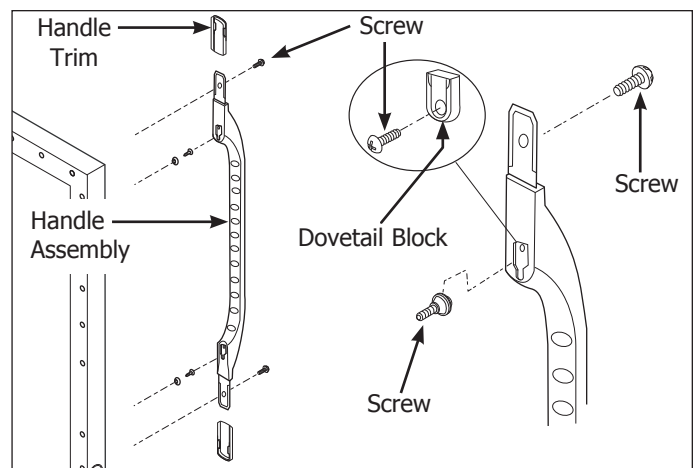

Figure 2-6. Handle Removal

Electronic Temperature Control

The electronic temperature control is located on the freezer door. Temperature is factory preset to provide satisfactory food storage. When the freezer is first plugged in, all LED's will turn on and the control will beep three times and the temperature setting of "4" will be displayed. This setting will provide satisfactory food storage temperatures.

Setting Selection

Adjust the temperature setting by pressing the up arrow or the down arrow. Allow several hours for the temperature to stabilize between adjustments.

"O-F-F" is displayed when the freezer is turned off. To turn the freezer off, press the down arrow three times after the "1" temperature setting is displayed. OFF will turn off the compressor, the fan, the defrost system, and any alarms, but the interior lights will continue to function.

To turn the freezer on, press the up arrow three times to get the "1" setting. Continue pressing the up arrow until desired setting appears. When the freezer is unplugged, the temperature setting will be retained.

Control Lock

To keep the temperature setting from being accidentally changed, the control may be locked. This is done by pressing Alarm Reset for three seconds. "L" will then appear on the display for one second. "L" will also appear for 1 second any time a key is pressed. To unlock the control, press Alarm Reset for 3 seconds. For the first second, "U" will appear, and then the current temperature setting will appear.

Defrost Timing

After each 12 hours of accumulated compressor run time, 30 minutes of defrost will begin. During these 30 minutes, the defrost heater will run until the termination switch opens. After the thirty minutes, the compressor will run.

Manual Defrost

To manually enter the defrost mode, turn the freezer off, then press the down arrow an additional four times. A "d" will flash on the display for the thirty minutes of the defrost cycle. To exit the manual defrost before it is complete, press the down arrow four times.

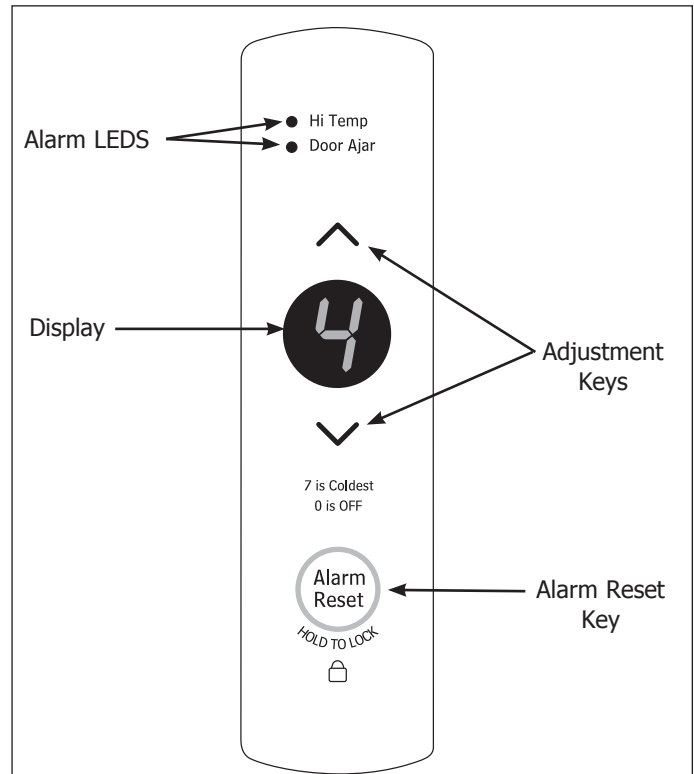

Figure 4-1. EZ Set Control

When the defrost mode ends, the freezer will go back to the previous temperature setting and the compressor run time will be reset.

Showroom Mode

Showroom Mode allows a person to demonstrate the freezer features without turning on the compressor and fan or going through defrost. During Showroom Mode, all buttons operate and after the temperature setting a "." will be displayed. The interior light will operate and there will be no alarms in the Showroom Mode.

To enter the Showroom Mode, press the up arrow and the down arrow at the same time while the freezer power cord is disconnected then reconnected to the AC power supply. An "S" will appear for three (3) seconds on the display and then the temperature setting and decimal point will appear. The Showroom Mode is retained if the freezer is unplugged.

To exit the Showroom Mode, press the up arrow and the down arrow at the same time while the freezer power cord is disconnected then reconnected to the AC power supply. When display illuminates on power-up, the decimal point will not be visible.

Section 3 Electronic Control

Service Diagnostic Mode

Initiate Service Mode

To enter the Service Mode, lock the keyboard then press and hold the up arrow and the down arrow for three seconds (until the display changes to "8").

When the diagnostics mode is entered, the compressor is turned off and the digit "8" is displayed for three seconds. After three seconds, the sequential information below will be displayed.

1. Blank for 0.5 seconds
2. Model ID for 1 second (See Table)
3. Blank for 0.5 seconds
4. Software Version and LED test for 3 seconds.
 - a. Hi Temp LED illuminates during display of 1st digit of the version number for one second,
 - b. Door Ajar LED illuminates during display of 2nd digit of the version number for one second.
 - c. Both LED's illuminate during display of 3rd digit of the version number for one second.
5. Blank for 0.5 seconds
6. Thermistor status ("0" for open, "C" for close or "-" for good thermistor) for three seconds.
7. 10 seconds for power check. During this time each key activates a specific load.
 - a. **UP** key activates the compressor and lowercase "c" is displayed.
 - b. **DOWN** key activates defrost heater and lowercase "d" is displayed
8. **MUTE** key activates the light and an "L" is displayed. 10 seconds after the last key press, the system will exit the diagnostic mode, automatically assuming the default temperature setting. If required, the compressor restarts after 13 minutes.

Type (Found on Serial Plate)

Model Description	Model #
U21F	0
U17F	1
U14F	2

Error Modes

If the thermistor is open, the display will alternate between "E" and "9".

If the thermistor is shorted, the display will alternate between "E" and "8".

If a key is stuck for more than 30 seconds, the display will alternate between "E" and "7".

Thermistor Resistance Chart

Temp °C	Temp °F	Nominal Resistance Ohms	Max. Ohms	Min. Ohms	Tolerance % +/-
0°	32°	32,654	33,604.72	31703.29	2.91
-15°	5°	72,940	75,283.21	70,596.79	3.21
-20°	-4°	97,060	100,283.44	93,836.56	3.32
-30°	-22°	177,000	183,293.70	170,706.30	3.55
-40°	-40°	336,000	349,139.51	322,860.49	3.91

Alarms

Door Ajar Alarm

When the door is left open for five (5) minutes or more, the Door Ajar LED will light up and the control will beep every five seconds. The alarm will be turned off when the door is closed or the Alarm Reset button is pressed. The LED light will stay on until the door is closed. If the door is not shut after five (5) minutes, the alarm will sound again. If after fifteen minutes the door is not shut, the interior light will turn off.

High Temperature Alarm

The High Temp LED will turn on and the control will beep every five (5) seconds if the temperature of the cabinet remains above 23°F for more than one hour. The alarm will be turned off when the Alarm Reset button is pressed, but the High Temp LED will remain lit until the temperature is again below 23°F.

Instructions for Programming EZ Set Controls :

Programming is determined by Model size.

Your Model size is shown on the serial plate inside the freezer as "Type 14F, 17F, 21F".

After plugging in the unit, wait for the display to flash the type Number "1".

1. For type U17F models, use this "1" and press the alarm reset key to lock it in.
2. For type U21F models, press the down key to display "0", then press the alarm reset key to lock it in.
3. For type U14F models, press the up key to display "2", then press the alarm reset key to lock it in.

To change the type programming procedure:

1. With unit unplugged, press and hold the up, down, and alarm reset keys while plugging in the unit.
2. The display will flash "1".
3. Release the keys and follow the programming instructions listed above.

Section 3 Electronic Control

Precision Set Control

Power-up Condition

Connect unit to household power supply. The power up tone will sound and the two 7 segment display digits illuminate for 2 seconds. The actual cabinet temperature will be displayed if it is above the current temperature setting. The control will display a High-Temp LED if above 23°F, but the High-Temp alarm will not sound. After the set temperature falls below 23°F for the first time, the High-Temp LED turns off and the High-Temp duration function is enabled.

Initial Power On Reset defaults are:

1. Temperature units are in Fahrenheit.
2. Temperature setting is 0°F (-18°C).
3. Extreme or Quick Freeze (depending on model type) is Off.
4. Control Lock is Off.

Setting Selection

The user may select any temperature setting from -10°F to 10°F (-23°C to -12°C) by pressing the Up or Down buttons. Press the Down button to lower the temperature inside the freezer. The display number will decrease with each press until "-10°F" (or -23°C) is reached. Press the Up button to increase the temperature inside the freezer. The display number will then increase with each Up press until the display reads "10°F" (or -12°C).

Once "10°F" (or -12°C) is displayed, press the Up button three times within three seconds to change the temperature from "10°F" (or -12°C) setting to the "Off" setting. Once the freezer is turned Off and the display shows "OF" the user must press the Down button three times within three seconds to turn the freezer back On. The freezer will then display "10", the highest temperature setting available. In the "OFF" position, the compressor, defrost heater, and alarms are disabled.

WARNING

Turning the freezer control to off does not remove power from the unit.

To ensure complete removal of power, unplug the power cord from the wall outlet.

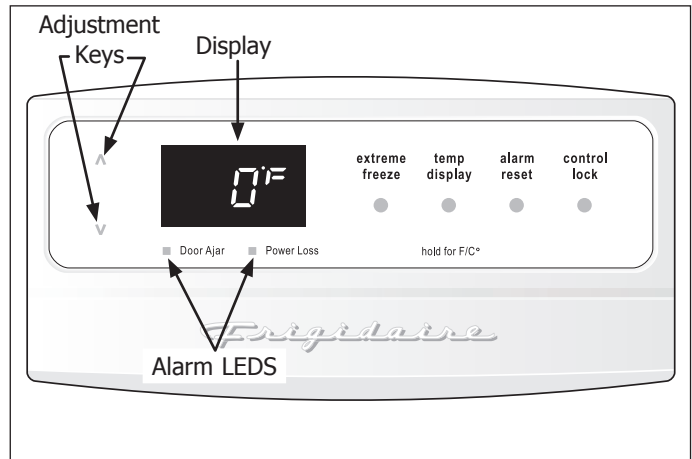

Figure 4-2. Precision Set Control

Control Lock

Press and hold the Control Lock key for three seconds to activate or deactivate the function. The Control Lock feature prevents the user from changing the temperature and freeze settings. At the first press of any key, the key press click tone will be heard and the display will show "LO", but no other change will take place. Holding the Control Lock key for three seconds will activate or deactivate the Control Lock feature. After three seconds, the accept tone sounds and the Control Lock LED (if so equipped) is activated. In lockout mode, when any key is pressed, the invalid key tone will be heard and "LO" will be displayed for 1 second. When the lockout is deactivated, the Control Lock LED is turned off and the display shows "UL".

Display and Temperature Scale (F°/C°)

Pressing the Temp Display key will toggle the temperature display on or off. Alarm LED's and key press functions will display for 0.5 seconds if the temperature display is off. Holding the Temp Display key will change the displayed temperature from Fahrenheit (default) to Celsius. Hold Temp Display key again to change back to previous temperature scale.

Door Alarm

Whenever the door is left open, the red Door Ajar LED will illuminate. If the door is left open for longer than 5 minutes, the audible alarm sounds. The display will not change. Close the door or press the Alarm Reset key to turn the audible alarm off. The Door Ajar LED remains on until the door is closed. When the door is closed, the Door Ajar alarm time period is reset.

Extreme or Quick Freeze

Pressing Extreme Freeze or Quick Freeze key turns the compressor on for 72 hours. The Extreme Freeze LED (if so equipped) is illuminated when this function is engaged and the acceptance tone sounds. The display will show "-F-". The Extreme Freeze key toggles the state On or Off. The user is allowed to change the set temperature while in Extreme Freeze mode. The new set temperature will be used when the Extreme Freeze cycle is complete.

Defrost will function normally during Extreme Freeze. If Extreme Freeze is activated during defrost, the LED and the display will reflect the mode, but the compressor will not come on until after the defrost cycle is completed. Extreme Freeze will not engage if the temperature setting is "OFF". The freezer will return to the previous temperature setting after the 72 hours.

High Temperature Alarm

The High Temperature audible alarm and LED are disabled for 1 hour after entering a defrost cycle. The audible alarm is also disabled until the cabinet temperature falls below 23°F for the first time, then the audible alarm is enabled. If the cabinet temperature rises above 23°F for more than 1 hour, the audible alarm sounds.

If the temperature of the cabinet exceeds 23°F, the High Temp LED will turn on, and the display will show the actual measured temperature inside the unit.

Showroom Mode

Showroom mode allows a sales person to demonstrate the freezer features without turning the compressor on or going through defrost cycles. All keys will operate normally during showroom mode. The display will indicate the "Set Temperature" not the "Thermistor Temperature". The cabinet light will operate as otherwise specified during showroom mode but the compressor and defrost heater will remain Off. No visual or audible alarms will occur during showroom mode.

To initiate Showroom Mode, press and hold the Up and Down keys simultaneously and apply AC power. The display will show "E5" (Enter Showroom) for 3 seconds. If power is removed and restored, the display will again show "E5" to indicate it remains in Showroom Mode. To cancel showroom mode, repeat the initiate procedure.

Section 3 Electronic Control

Service Diagnostic Mode

To enter service diagnostics mode, place the control in the lock mode by pressing and holding Control Lock key for 5 seconds. Then press and hold the Up and Down keys simultaneously for 5 seconds. When diagnostics mode is entered, the following information will be displayed for two seconds at a time. The system will then wait for load testing for 10 seconds, exit diagnostic mode automatically, and assume the default temperature setting. If load testing is performed, a 10 second wait cycle is re-established after each key press.

- Three short confirmation beeps are issued.
- Left digit displays "8".
- Left digit blanks and second digit displays "8".
- The following LEDs are illuminated: (-), (°C), (°F), (HRS), (Door Ajar), (Power Loss). Blanked after 2 seconds.
- The following LEDs are illuminated: (Hi Temp), (Duration), (Quick or Extreme Freeze), (Control Lock) Blanked after 2 seconds.
- Door Switch Status with tone ("dO" or "dC")
- Displays "Id" (model ID) with tone.
- Displays Model ID.

Type (Found on Serial Plate)

Model Description	Model #
21cf	0
17cf	1
14cf	2

- Displays "5F", (Software Version) with tone.
- Displays "00"
- Displays Software Version #
- Thermistor Status with tone ("tO" for open, "tC" for closed or "--" for good thermistor).
- Tone and enters Load Test mode for 10 seconds.
- Press Down key. Displays "HE" and turns on heater.
- Press Up key. Displays "CP" and turns on compressor.
- Press Temp Display key. Displays "LA" and illuminates cabinet lamp.

Thermistor Error Mode: Alternating Flashing Display of E8/Temp or E9/Temp

Upon entering the Thermistor Error mode and an open thermistor condition is present, the display will alternately display an "E9" for 0.5 seconds and "-10°F" for 0.5 seconds (-23°C if in Celsius mode). If a shorted thermistor condition is present, the display will alternately display an "E8" for 0.5 seconds and "-10°F" for 0.5 seconds (-23°C if in Celsius mode).

Fail Safe Error Mode: Alternating Flashing Display of E7/Temp

If Fail Safe Mode is initiated due to a stuck key, the freezer will run at -10°F (-23°C) continuously with a 30 minute defrost time every 12 hours of compressor run time. Audible alarms will be limited to one minute and will cancel automatically. In case of a thermistor error, Thermistor Error Mode will be initiated instead of Fail Safe mode. Thermistor Error Mode takes precedence over Fail Safe mode.

Power Loss Recovery Alarms

When power lost and then restored, the microcontroller performs two checks:

1. Checks the temperature.
2. Checks for power loss duration greater than 1 hour.

If the cabinet temperature is less than 10 degrees higher than the set point temperature, no alarm occurs.

If the cabinet temperature is greater than or equal to 10°F above the set temperature, the Power Loss LED will light, and an audible alarm will sound.

If the cabinet temperature is above 23°F and the measured duration of power loss is less than 1 hour, the Hi-Temp LED will turn on, the Power Loss LED will turn on and an audible alarm will sound.

If the cabinet temperature is above 23°F and the measured duration of power loss is greater than 1 hour and less than 36 hours, the Power Loss LED will be on and the display will alternate between condition #1 and condition #2 below.

1. The cabinet temperature measured at the time power was restored will be displayed. The Hi-Temp LED will be on, the alarm will sound and the display will show the measured temperature.
2. The power loss duration will be displayed. The Hi-Temp LED, Duration LED and HRS LED will be on and the display will show measured hours. A maximum of 36 hours will be displayed.

The high-temp duration condition can be cleared by pressing the Alarm Reset key.

NOTE

Instructions given here are furnished as a guide. Persons attempting to use these instructions to make repairs to the sealed refrigeration system should have a working knowledge of refrigeration and previous training on sealed system repair, and an EPA certification for servicing refrigeration systems.

IMPORTANT

Effective July 1, 1992, the United States clean air act governs the disposal of refrigerants such as R-134a. Therefore, when discharging or purging the sealed system use an EPA approved refrigerant recovery system as outlined in the final rule on the protection of stratospheric ozone and refrigerant recycling, which was published in the Federal Register May 14, 1993.

NOTE

Electrolux Home Products Inc. does not permit the use of recovered refrigerant in the servicing of our products for in-warranty and out-of-warranty repairs or for products covered by service contracts. Therefore, only new refrigerant or refrigerant that has been reclaimed back to new specifications by a refrigerant manufacturer is to be used.

Definitions

Recovery:

To remove refrigerant in any condition from a system and store it in an external container without necessarily testing or processing it in any way.

Recycling:

To clean refrigerant for reuse by oil separation and single or multiple passes through devices, such as replaceable core filter-driers, which reduce moisture, acidity and particulate matter. This term usually applies to procedures implemented at the field job site or at a local service shop.

Reclaim:

To reprocess refrigerant to new product specifications by means which may include distillation, will require chemical analysis of the refrigerant to determine that appropriate product specifications are met. This term usually implies the use of processes or procedures available only at a reprocessing or manufacturing facility.

Safety Warnings

Compressor Testing

Whenever testing a compressor, extreme caution should be used to prevent damaging the terminals. A compressor with a damaged terminal or a grounded winding can expel a terminal from its insulated housing when the compressor is energized. If this happens, a mixture of refrigerant and oil will be released that could be ignited by an external heat source (open flame, heater, etc.). Also, if there is air in the system when this happens, a spark at the compressor shell could ignite the refrigerant and oil mixture.

Charging Sealed Systems

Overcharging a refrigeration system with refrigerant can be dangerous. If the overcharge is sufficient to immerse the major parts of the motor and compressor in liquid refrigerant, a situation has been created which, when followed by a sequence of circumstances can lead to the compressor shell seam separating.

A hydraulic block occurs, preventing the compressor from starting. This condition is known as locked rotor. Electric current continues to flow through the compressor motor windings which become, in effect, electric resistance heaters. The heat produced begins to vaporize the excess refrigerant liquid causing a rapid increase in system pressure. If the compressor protective devices fail, the pressure within the system may rise to extremes far in excess of the design limits. Under these conditions, the weld seam around the compressor shell can separate with explosive force, spewing oil and refrigerant vapor which could ignite.

To eliminate this exceedingly rare but potential hazard, never add refrigerant to a sealed system. If refrigerant is required, evacuate the existing charge and recharge with the correct measured amount of the refrigerant specified for the system.

Section 4 Refrigeration

WARNING

Wear approved safety glasses when working with or on any pressurized system or equipment. Have an approved dry type fire extinguisher handy when using any type of gas operated torch.

1. All joints to be soldered must have proper fit. Clearance between tubes to be soldered should be from .001" to .006". It is not practical to actually measure this; however, you do not want a dry fit or loose fit. Tubing joints should overlap about the distance of their diameter except for restrictor tubes, which should be inserted 1.25".
2. Clean all joint areas with fine steel wool or preferably an abrasive cloth, such as grit cloth No. 23 or Scotch-Brite.
3. Apply a thin film of liquid flux recommended for silver soldering to surfaces to be joined and to surfaces immediately adjacent to joint.

CAUTION

During application of heat, use wet cloths to prevent heat from conducting to areas other than the soldered joint. Use a sheet of metal or torch guard pad as a heat deflector to keep flame away from inflammable materials and painted surfaces.

4. Align tubing so no stress is on joint. Do not move tubing while solder is solidifying or leaks will result.
5. Use a torch of adequate capacity so joint can be quickly heated with a minimum of heat travel to other points. Use a good grade of silver solder.
6. Solder connections. If tubing is properly cleaned and fluxed, solder will flow readily. Use only enough solder to make a good bond.
7. Allow joint to cool, then wash exterior with water to remove flux.

Basic Components

The basic components of a refrigerator are a compressor, condenser, evaporator, heat exchanger (capillary tube and suction line) and drier.

Refrigerant Cycle

The refrigerant cycle is a continuous cycle that occurs whenever the compressor is in operation. Liquid refrigerant is evaporated in the evaporator by the heat that enters the cabinet through the insulated walls and by the heat from product load and door openings. The refrigerant vapor is then drawn from the evaporator, through the suction line to the compressor. Compression raises the pressure and temperature of the vapor in the compressor and the vapor is then forced through the discharge valve into the discharge line and into the condenser. Air passing over the condenser surface removes heat from the high pressure vapor which then condenses to a liquid. The liquid refrigerant then flows from the condenser to the evaporator through the small diameter liquid line (capillary tube). Before it enters the evaporator, the liquid refrigerant is sub-cooled in the heat exchanger by the low temperature suction vapor in the suction line. When refrigerant is added, the frost pattern will improve, the suction and discharge pressures will rise, the condenser will become hot and the wattage will increase.

Low/High Side Leak or Undercharge

A loss of refrigerant can result in any of the following:

1. Excessive or continuous compressor operation.
2. Above normal freezer compartment temperature.
3. A partially frosted evaporator (depending on amount of refrigerant loss).
4. Below normal freezer compartment temperature.
5. Low suction pressure (vacuum).
6. Low wattage.

The condenser will be “warm to cool”, depending on the amount of refrigerant lost.

In the case of a low side refrigerant leak resulting in complete loss of refrigerant, the compressor will run but will not refrigerate. Suction pressure will drop below atmospheric pressure and air and moisture will be drawn into the system saturating the filter drier.

If there is reason to believe the system has operated for a considerable length of time with no refrigerant and the leak occurred in the low side of the system, excessive amounts of moisture may have entered the system. In such cases the two stage service Dryer Filter part number 5303918288 and vacuum procedure listed under Refrigerant Leaks need to be followed to prevent repetitive service.

If a slight undercharge of refrigerant is indicated and no leak can be found after a thorough leak test, the charge can be corrected without changing the compressor.

If a high side leak is located and some refrigerant remains in the system it is not necessary to change the compressor.

Testing for Refrigerant Leaks

NOTE

The line piercing valve (clamp-on type) should be used for test purposes only. It must be removed from system after it has served its purpose.

If the system is diagnosed as short of refrigerant and the system has not been recently opened, there is probably a leak in the system. Adding refrigerant without first locating and repairing the leak or replacing the component will not permanently correct the difficulty. The leak must be found. Sufficient refrigerant may have escaped to make it impossible to leak test effectively. In such cases, add a ¼” line piercing valve to the compressor process tube. Add sufficient refrigerant vapor to increase the pressure to 40 to 50 lb. per sq. in. Check the low side for leaks. Run the compressor 2 or 3 minutes and check the high side for leaks. Recover refrigerant using an EPA approved recovery system.

Compressor Replacement

To check for contamination, obtain oil sample from old compressor.

1. If the oil has burned odor, but no color change or residue — follow instructions on page 4-5 “Installing A New Compressor”.
2. If oil has a burned odor and a sugar or gritty feel as well as showing signs of contamination (dark color), follow instructions in next section, To Flush The System. Remove as much of contamination as possible from system before installing new compressor and filter-drier.

CAUTION

NEVER install a new compressor without first checking for possible system contamination.

NOTE

It is recommended that system be flushed with dry Nitrogen. However, if refrigerant is used to flush the system you must look at the serial plate to see what type of refrigerant is used in the system. This is the only refrigerant that can be used to flush the system and it must be recovered.

Section 4 Refrigeration

To Flush The System

CAUTION

Use extreme care when using Dry Nitrogen to flush systems. Pressure in nitrogen cylinder could be as high as 2000 psi. Nitrogen cylinder must be equipped with approved pressure regulator and pressure relief valve. Ensure that your hoses have adequate ratings for pressure involved and that all of your equipment is in good condition. The end of the flushing hose on this tank regulator must be equipped with a hand shut-off valve (Robinair No. 40380). Close hand shut-off valve and adjust nitrogen regulator to correct pressure before proceeding with flushing procedure.

To Use Dry Nitrogen To Flush The System:

1. Remove compressor and filter-drier. Connect process coupling to outlet tube of condenser.
2. Fasten cloth over other end of coil to prevent old oil from spraying over room.
3. Connect hand shut-off valve on flushing hose to process coupling.
4. Slowly open hand shut-off valve and allow nitrogen to flow through condenser until discharge is clear.

CAUTION

DO NOT exceed 300 Psi.

5. Disconnect cap tube from evaporator. Flush evaporator in same manner as condenser.

CAUTION

DO NOT exceed 150 Psi.

6. Flush cap tube. This is only possible if you have proper service valve adapter.

CAUTION

DO NOT exceed 300 Psi.

7. Reassemble system.

To Use Refrigerant To Flush The System:

CAUTION

Refrigerant used for flushing must be recovered into a recovery system. Meter amount of refrigerant used for flushing with your charging cylinder. **DO NOT OVERFILL THE BAG.**

1. Disconnect the suction and discharge lines from the compressor and remove the filter-drier. Connect process coupling to outlet and inlet tube of condenser.
2. Connect hose to outlet process coupling and charging cylinder. Connect another hose to inlet coupling and recovery system.
3. Open charging cylinder and allow refrigerant to flow through condenser until discharge into bag is clear.

NOTE

The line piercing valve (clamp-on type) should be used for test purposes only. It must be removed from system after it has served its purpose.

4. Disconnect capillary tube from evaporator. Flush evaporator in same manner as condenser.
5. Flush cap tube. This is only possible if you have proper service valve adapter.
6. Reassemble system.

Installing a New Compressor

NOTE

Entirely new compressors have been developed or use with R-134a and Ester oil refrigeration systems. Both compressor and electric motor have been modified. Old compressors intended for R-12 refrigerant must not be used for new systems charged with R-134a.

Replacement of compressor and installation of filter-drier must be done in a continuous sequence so system is exposed to atmosphere no longer than necessary.

All replacement compressors are shipped with rubber plugs in the suction, discharge and process tubes and contain the correct oil charge and a holding charge of inert gas. Compressors have a low-side process tube attached to the compressor shell. A high-side process tube is attached to the filter-drier.

WARNING

Do not operate reciprocating compressor when charging liquid refrigerant into system through its process tube.

Replacement compressors for refrigerators may have an oil cooler even if the original compressor did not. If the product is not equipped for an oil cooler, leave the plastic caps in place and install the compressor connecting only to the suction and discharge lines of the new compressor.

Before installing the replacement compressor remove the discharge plug and check for the pop sound of the inert gas leaving the compressor.

CAUTION

DO NOT use compressor if you do not hear this sound.

If the compressor checks OK, reinstall the plug. Do not remove any of the plugs again until the compressor is in position and you are ready to braze the lines.

CAUTION

On R-134a systems, compressor must NOT be left open to atmosphere for more than 10 minutes to prevent moisture contamination of oil.

NOTE

The following instructions are generalized to help the technician understand the procedures of sealed system repairs. See Section 5 Component Teardown on the exact steps of accessing the components of the refrigeration system.

A new compressor which is cold (e.g. after having been kept in a cold service van) should be left to warm to the surrounding temperature before the plugs on the compressor connections are removed. This will help prevent condensation from forming in the oil and the compressor. Also, avoid opening the system when any of the components or lines are cold.

NOTE

Release holding charge (release slowly to avoid oil discharge) on new compressor to ensure there is no leak in seam or tubing. Reinstall rubber plug.

1. Disconnect electrical supply to refrigerator.
2. Remove compressor access panel.
3. Remove all components needed to pull the compressor assembly from the unit.
4. Pull compressor assembly straight out.
5. Recover refrigerant by using EPA approved recovery system.

NOTE

If low-side process tube is too short, silver solder four inch piece of tubing onto process tube at this time.

6. Remove leads from compressor motor terminals.
7. Remove mounting clips and washers.
8. After refrigerant is completely recovered, cut suction and discharge lines as close to compressor as possible. Leave only enough tubing to pinch off and seal defective compressor. Plug or tape any open system tubing to avoid entrance of moisture and air into system. Remove inoperable compressor and transfer mounting parts to new compressor.
9. Install new compressor in exact same manner as original compressor.

Section 4 Refrigeration

10. Reform both suction and discharge lines to align with new compressor. If they are too short, use additional lengths of tubing. Joints should overlap 0.5" to provide sufficient area for good solder joint. Clean and mark area where tubing should be cut. Cut tubing with tubing cutter. Work as quickly as possible to avoid letting moisture and air into the system.
11. Solder all connections according to soldering procedure.
12. Remove original filter-drier.



CAUTION

DO NOT unbrazed old filter-drier from system. This will vaporize and drive moisture from desiccant back into system. The old filter-drier should be cut out of system.

13. Install new filter-drier at condenser outlet.
14. Evacuate and charge system using recommended procedure described under Evacuating and Recharging.
15. Reconnect compressor terminal leads in accordance with refrigerator wiring diagram.
16. Reassemble unit.

Condenser Replacement



NOTE

The following instructions are generalized to help the technician understand the procedures of sealed system repairs. See Section 5 Component Teardown on the exact steps of accessing the components of the refrigeration system.

1. Disconnect electrical supply to refrigerator.
2. Remove compressor access panel.
3. Recover refrigerant by using EPA approved recovery system.
4. Remove condenser fan mounting screws.
5. Unplug fan motor harness located in back of fan motor.
6. Remove fan motor and fan blade.
7. After refrigerant is completely recovered, disconnect inlet and discharge lines from condenser.
8. Lift front of condenser and pull out of retainers mounted to the drain pan.
9. Remove old condenser out the back of cabinet.
10. Install replacement condenser.
11. Remove original filter-drier.



CAUTION

DO NOT unbrazed old filter-drier from system. This will vaporize and drive moisture from desiccant back into system. The old filter-drier should be cut out of system.

12. Install new filter-drier at condenser outlet.
13. Evacuate and charge the system using recommended procedure described under Evacuating and Recharging.
14. Reassemble unit.

Filter-Drier Installation

Any time the sealed system is opened and the refrigerant charge is removed, the liquid line filter-drier must be replaced and the system thoroughly evacuated before replacing refrigerant.

CAUTION

DO NOT unbraid old filter-drier from system. This will vaporize and drive moisture from desiccant back into system. The old filter-drier should be cut out of system.

NOTE

The following instructions are generalized to help the technician understand the procedures of sealed system repairs. See Section 5 Component Teardown on the exact steps of accessing the components of the refrigeration system.

1. Disconnect electrical supply to freezer.
2. Recover refrigerant by using EPA approved recovery system.
3. Using a 3 cornered file, score a groove around capillary tube as close to old filter-drier as possible. Break capillary tube along score mark from filter-drier.
4. Cut condenser outlet tube at filter-drier. Discard filter-drier.
5. Thoroughly clean condenser outlet tube and capillary tube.
6. Place inlet connection of filter-drier over condenser tube approximately 1/4" and solder.
7. Insert capillary tube input end into filter-drier outlet. Do not allow tube to bottom against screen. Solder carefully so that solder does not plug capillary tube.
8. Install process tube adapter to filter-drier.
9. Evacuate and charge system using the recommended procedure described under Evacuating and Recharging.
10. Reassemble unit.

Evaporator and Suction Line Replacement

NOTE

The following instructions are generalized to help the technician understand the procedures of sealed system repairs. See Section 5 Component Teardown on the exact steps of accessing the components of the refrigeration system.

1. Disconnect electrical supply to refrigerator.
2. Recover refrigerant by using EPA approved recovery system.
3. Remove shelving.
4. Remove evaporator cover.
5. Remove evaporator from its installation position.
6. Cut or remove suction line from compressor.
7. Cut filter-drier from condensing unit.

CAUTION

DO NOT unbraid old filter-drier from system. This will vaporize and drive moisture from desiccant back into system. The old filter-drier should be cut out of system.

8. Remove sealant from cabinet where suction line enters.
9. Remove evaporator and suction line as one piece.
10. Install new evaporator with attached suction line.
11. Seal cabinet.
12. Install new filter drier at condenser outlet.
13. Evacuate and charge system using the recommended procedure described under Evacuating and Recharging.

Section 4 Refrigeration

CAUTION

Check the serial plate for the correct refrigerant type. It is extremely important to verify the type of refrigerant in the system before starting any sealed system repairs.

With the possible exception of the vacuum pump, all service equipment that comes in contact with R-134a during evacuation and recharging must be dedicated. Accordingly, R-134a will require a dedicated charging cylinder, manifold gauge set, process tube adapters, and hoses. Any residual mineral oil on other tools (tubing cutter, etc.) must be thoroughly cleaned off before using on R-134a/Ester oil systems. It will be necessary to check with the manufacturer of your vacuum pump for refrigerant and oil compatibility issues.

If you use a vacuum pump with mineral oil to evacuate an R-134a system, it is **ABSOLUTELY ESSENTIAL** to have a shut-off valve between the pump and your manifold gauge set as shown on page 4-10. The hand valve must be closed during all times when the vacuum pump is not operating. This will prevent the migration of mineral oil vapor into the R134a/Ester oil system. If the vacuum pump should stop during evacuation for any reason, the hand pump shut-off valve must be closed immediately.

Insure that your refrigeration hoses are specified for use with R-134a refrigerant. Research has shown that compounds in standard refrigeration hoses may enter sealed systems and ultimately restrict the cap tube in an R-134a system.

Equipment Needed for Evacuation & Recharging:

- Heated charging cylinder
- Standard 3-port manifold gauge set:
 - 4 charging hoses
 - Tee fitting with valve core stem removed (Robinair No. 40396)
 - Hand shut-off valve (Robinair No.40380)
- Two stage vacuum pump
- Process tube adapter kit (Robinair No.12458)
- Tubing cutter
- Pinch-off tool capable of making leak proof seal
- Complete brazing torch set
- Small 3-corner file
- Grit cloth or Scotch-Brite
- 45% silver solder and flux
- Heat Gun

Installing Evacuation and Recharging Equipment

1. Disconnect freezer from electrical supply.
2. If compressor was replaced, install correct sized process tube adapter on process tube.
If compressor was not replaced, cut process tube with tubing cutter leaving as much tube as possible and install correct size process tube adapter.
3. Install correct sized process tube adapter on high-side process tube.
4. Attach refrigeration service gauge manifold to system in following order:
 - Low-side (compound gauge) hose to suction side process tube adapter.
 - High-side (pressure gauge) hose to high-side process tube adapter.
 - Center port manifold hose before hand shut-off valve to charging cylinder.
 - Center port manifold hose after hand shut-off valve to vacuum pump.

WARNING

R-134a systems are particularly susceptible to moisture contamination which can only be prevented by evacuating the System for a minimum of 30 minutes to attain a minimum 29.9 inch (500 micron or lower) vacuum.

Evacuating System

To achieve the required levels of evacuation, a properly maintained two stage vacuum pump in good condition is required. It is absolutely essential to maintain your vacuum pump according to the manufacturer's instructions including required oil changes at the recommended intervals. Vacuum pump oil should always be changed after evacuating a contaminated system.

Vacuum pump performance should be checked periodically with a micron gauge.

1. Make certain that charging cylinder valve, hand shut-off valve, and manifold gauge valves are closed.
2. Start vacuum pump.
3. Open hand shut-off valve and slowly open both manifold valves, turning counterclockwise, for two full rotations.

CAUTION

If high vacuum equipment is used, just crack both manifold valves for a few minutes and then open slowly for the two full turns counterclockwise. This will prevent the compressor oil from foaming and being drawn into the vacuum pump.

4. Operate vacuum pump for a minimum of 30 minutes to a minimum of 29.9" (500 micron) vacuum.
5. Close hand shut-off valve to vacuum pump. Watch compound gauge for several minutes. If reading rises, there is a leak in the system, go to step 6. If no leak is indicated, stop vacuum pump. System is now ready for charging.
6. If a leak is indicated, stop vacuum pump and introduce a small charge of refrigerant into system by cracking valve on bottom of charging cylinder until system is pressurized to 40 or 50 lbs psi.

7. Leak test low-side. Close compound gauge. Run compressor for a few minutes and leak test high-side. When leak is found, recapture refrigerant using EPA approved recovery system. Repair and go back to step 1.

Charging The System

CAUTION

Check the serial plate for the correct refrigerant type. It is extremely important to verify the type of refrigerant in the system before starting any sealed system repairs. After charging the system with liquid be certain to wait at least 5 minutes before starting the compressor to give the refrigerant a chance to disperse throughout the system. Otherwise the compressor could be damaged by attempting to pump excessive quantities of liquid.

Preparing The Charging Cylinder:

1. Make certain that hand shut-off valve to vacuum pump is closed.
2. Close high-side manifold gauge valve.
3. Set charging cylinder scale to pressure indicated on cylinder pressure gauge.
4. Observe refrigerant level in sight glass. Subtract amount to be charged into system and note shut off point.
5. Open charging cylinder valve slowly and allow proper charge to enter system.
6. As soon as refrigerant in sight glass has gone down to predetermined level, close charging cylinder valve.

WARNING

Disconnect the charging cylinder heater at this time to prevent the cylinder pressure from exceeding its maximum limits.

7. Allow system to sit for five minutes.
8. Turn on refrigerator compressor. Run compressor for a few minutes and monitor system pressures.
9. When satisfied that the unit is operating correctly, clamp the high-side process tube with the pinch-off tool while the unit is still running.

Section 4 Refrigeration

10. Slowly open the high-side manifold gauge valve to allow the compressor to remove any refrigerant trapped in the high-side hose and the process fitting.
11. Close both of the manifold gauge valves. If the high-side gauge reading rises, the pinch-off must be corrected before proceeding.
12. Remove the high-side process tube adapter and solder the process tube closed.
13. Clamp the low-side process tube with the pinch-off tool while the unit is running. Remove the low-side process tube adapter and solder the process tube closed.
14. Check the process tubes for refrigerant leaks.

Final Leak Test

1. With the refrigerator turned OFF leak test all low-side system components.
2. Turn the unit ON and run until the condenser is warm. Leak test the high-side system components.

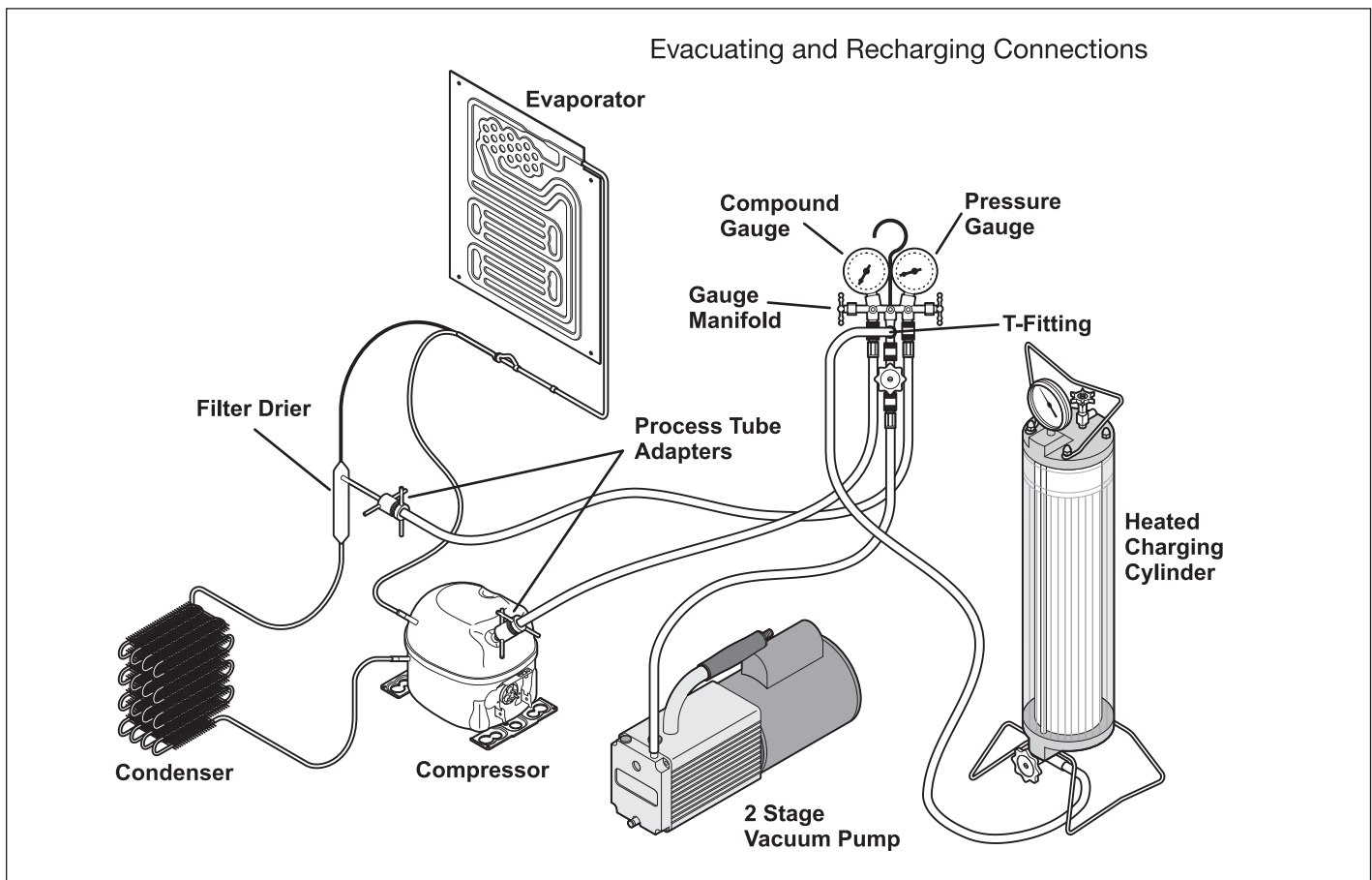

Verify Refrigerant Type In The System

CAUTION

R-134a and R-12 are completely incompatible. Before starting any sealed system repair, it is extremely important to check serial plate of product to verify the type of refrigerant in the system.

Dedicated Equipment

R-134a must not be mixed with other types of refrigerants. R-134a must be recovered in dedicated and properly identified recovery bags and tanks.

It will be necessary to check with the manufacturer of your recovery equipment to determine R-134a compatibility. Some recovery equipment manufacturers have changeover instructions for switching between refrigerant types. Protect yourself and your equipment by following all manufacturer guidelines.

Also, ensure that your refrigeration hoses are specified for use with R-134a refrigerant. Research has shown that compounds in standard refrigeration hoses may enter sealed systems and ultimately restrict the cap tube in an R-134a system.

R-134a Refrigeration Systems

The sealed refrigeration system will consist of the same basic components being utilized in the R-12 systems.

There is a 10% to 15% discharge pressure increase using R-134a, with a 5% to 10% decrease in suction pressure when compared to the same product with an R-12 system operating at 90°F (32°C) ambient temperature conditions. Lower suction pressures result from the lower density of R-134a refrigerant which effects refrigerant flow rate. R-134a systems commonly operate in a 1"-2" vacuum on the suction side.

Products using R-134a refrigerant will generally have a longer capillary tube to maintain a similar flow rate and some models will have a larger condenser to reduce the discharge pressures and lower start-up sound transmission.

Miscibility of R-134a and Ester Oil

A special synthetic oil known as Ester oil is used as a lubricant in refrigeration systems operating on R-134a. Ester oils are produced from alcohols and fatty acids and are available in several different variants. Ester oils have a pleasant aroma reminiscent of fruit.

Ester oils generally include various types of additives for improving certain properties such as viscosity, temperature sensitivity, etc. These additives are often aggressive, and skin contact with Ester oils should therefore be avoided.

One of the most important requirements made on a refrigerant system is that the oil mix with the refrigerant. Since mineral oil and ordinary synthetic oil DO NOT mix with R-134a, Ester oil is used for lubrication. Ester oil dissolves in R-134a.

Ester oil is broken down by chlorine and cannot be used with R-12 (R-12 contains chlorine) or any other compound containing chlorine. Therefore, R-134a refrigeration systems have virtually no tolerance for chlorine molecules from CFC refrigerants (R-134a is an HFC and contains no chlorine).

CAUTION

During R-134a service, it is extremely important to avoid using equipment that may contain residual amounts of mineral oil, CFC's or HCFC's which could enter and contaminate the sealed system.

Section 4 Refrigeration

For example, hoses that were used for a refrigeration system operating on R-12 may contain small quantities of mineral oil which can block the capillary tube in a system operating on R-134a. As little as one milligram may be sufficient to cause a blockage. In addition, sealed system components that have been used with CFC systems must not be used with R-134a systems. These components may contain residual amounts of refrigerant and oil which could damage an R-134a system.

At the earliest stage of development work on R-134a, tests were carried out on a different type of synthetic oil known as Poly-Alkaline Glycol (PAG). This oil is also used in certain air conditioning systems for cars. PAG and Ester oil DO NOT mix with one another. Service equipment used for R-134a / Ester oil must not come into contact with PAG.

Water In The Refrigeration System

Even in very small quantities, water in any refrigeration system can cause the following problems:

- Ice plugs in capillary tubes.
- Copper plating in compressor.
- Reactions with organic materials in systems.
- Corrosion of metals.

R-134a and Ester oil will aggravate the problem of water in the refrigeration system. Ester oil may react with water vapor and is hygroscopic (it will absorb water if it comes in contact with humid air). Water is also more soluble in R-134a than R-12.

To minimize the water content whenever service work is performed, the refrigeration system should always be thoroughly evacuated through process tube adapters on both the high and low sides of the system. Evacuation must be for a minimum of 30 minutes to at least a 29.9 inch (500 micron) vacuum.

VACUUM CHART		
Vacuum Inches Hg.	Microns	Boiling Point of Water °F
28.940	25000	77.9
29.530	10000	52.0
29.832	4600	32.0
29.882	1000	1.0
29.901	500	-11.2
29.915	150	-32.8
29.917	100	-38.2
29.919	50	-49.0

To achieve the required 29.9 inch (500 micron) vacuum, a properly maintained two-stage vacuum pump in good condition is required. A two stage pump can reach a deeper vacuum than a single stage because the exhaust from the first pumping stage is discharged into the second pumping stage. This means the second stage begins pumping at a lower pressure so a lower ultimate vacuum can be achieved.

2-Stage Vacuum Pump

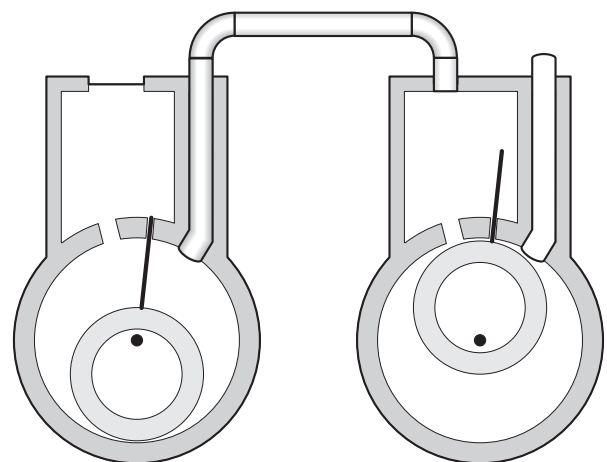

Vacuum Pump Maintenance

It is absolutely essential to maintain your vacuum pump according to the manufacturer's instructions including required oil changes at the recommended intervals. Vacuum pump oil should always be changed after evacuating a contaminated system. Vacuum pump performance should be checked periodically with a micron gauge.

Vacuum pump suppliers may or may not recommend changing the vacuum pump oil to the same type that's in the system being evacuated. Some manufacturers may recommend a vacuum pump that's dedicated to R-134a systems.

Robinair has stated that their current and discontinued vacuum pump models, using mineral oil currently specified for use in their vacuum pumps, can be used to evacuate R-134a/Ester oil systems. Robinair also states that it is acceptable to alternate between evacuating R-12/mineral oil and R-134a/Ester oil systems without adversely affecting the vacuum pump's performance.

For other brands of vacuum pumps, check with the manufacturer for restrictions and guidelines when using with R-134a.

CAUTION

If you use a vacuum pump with mineral oil to evacuate an R-134a system, it is ABSOLUTELY ESSENTIAL to have a shut-off valve between pump and your manifold gauge set as shown on page 4-10. The hand valve must be closed during all times when vacuum pump is not operating. This will prevent migration of mineral oil vapor into R134a/Ester oil system. If vacuum pump should stop during evacuation for any reason, the hand pump shut-off valve must be closed immediately.

Refrigerant Leaks

A system with R-134a and Ester oil will become saturated with moisture much faster than a system with R-12 and mineral oil. If your leak was in the low side of the refrigeration system when the compressor is running the pressure in the low side will go into a vacuum. As additional refrigerant leaks out the system will go deeper into a vacuum. The system running in this vacuum will allow air and moisture to be pulled into the sealed system. The moisture pulled in can then be mixed in to the Ester oil in the compressor.

If the product has had a low side leak you will need to install the two stage service dryer filter part number 5303918288. You must heat the crankcase area of the compressor using a heat gun on the high heat setting throughout the 30 minutes you are running your vacuum pump to pull a vacuum on the system. Every 4 to 5 minutes while you are running your vacuum pump and heating the crankcase area, shake the compressor. By heating the crankcase you are heating the oil in the compressor. This will drive the moisture out of the oil. By shaking the compressor this will allow the moisture to come to the top of the oil faster so the vacuum pump can remove the moisture from the system.

Electrolux Home Products does not approve the use of the Sweep Charge for sealed system repair. This method of servicing sealed systems is often used to repair products in the field. The Sweep Charge does not adequately remove moisture from the oil in the compressor. In a R-134a system you will need to replace the compressor if the product has had a low side leak and you are servicing with the Sweep Charge procedure.

R-134a refrigerant molecules are smaller than R-12 molecules. This means that R-134a will pass more minor leaks and the rate of flow will be greater than for R-12. Therefore, it is now more important than ever to follow good brazing practices. Use a good grade of silver solder. A 45% silver solder is recommended.

Section 4 Refrigeration

Leak Detection

R-134a system leaks can be pinpointed by means of an electronic leak detector or by bubble solution.

Electronic leak detectors for R-134a service are currently available from several manufacturers. The least expensive models are non-selective detectors that will detect any type of emission or vapor present, regardless of its chemical composition. Some non-selective detectors designed for use with R-12 may have a much lower sensitivity when used with R-134a. However, newly designed detectors with good R-134a sensitivity are now available. Be sure to consult with the manufacturer before selecting or using a non-selective detector with R-134a.

Halogen-specific detectors use a specialized sensor that allows detection of compounds containing chlorine, fluorine, bromine, and iodine without being activated by other species. The major advantage of this type of detector is a reduction in the number of "nuisance alarms". Halogen-specific detectors are generally more expensive than non-selective detectors but feature higher sensitivity.

R-134a properties

The properties of R-134a are very similar to those of R12. The principal data for the two refrigerants are shown in the chart below.

	REFRIGERANTS	
	R-12	R-134a
NAME	Dichlorodifluoromethane	1,1,1,2--Tetrafluoromethane
Formula	CCl_2F_2	$\text{CH}_2\text{F}-\text{CF}_3$
Molecular Weight (g/mol)	120.93	102.3
Ozone Depletion Potential (ODP)	1	0
Global Warming Potential (GWP)	3.1	0.3
Boiling Point °F	-21.6	-15.7
Vapor Pressure (77°F)	80 psig	82 psig
Flammability	None	None
Solubility of Water in Refrigerant (wt% @ 77°F)	0.009	0.11

HFC-134a, CFC-12 Pressure Temperature Chart

°F	°C	HFC-134a	CFC-12		°F	°C	HFC-134a	CFC-12
-60	-51.1	21.8*	19.0*		55	12.8	51.1	52.0
-55	-48.3	20.4*	17.3*		60	15.6	57.3	57.7
-50	-45.6	18.7*	15.4*		65	18.3	63.9	63.8
-45	-42.8	16.9*	13.3*		70	21.1	70.9	70.2
-40	-40.0	14.8*	11.0*		75	23.9	78.4	77.0
-35	-37.2	12.5*	8.4*		80	26.7	86.4	84.2
-30	-34.4	9.8*	5.5*		85	29.4	94.9	91.8
-25	-31.7	6.9*	2.3*		90	32.2	103.9	99.8
-20	-28.9	3.7*	0.6		95	35.0	113.5	108.3
-15	-26.1	0.0	2.4		100	37.8	123.6	117.2
-10	-23.3	1.9	4.5		105	40.6	134.3	126.6
-5	-20.6	4.1	6.7		110	43.3	145.6	136.4
0	-17.8	6.5	9.2		115	46.1	157.6	146.8
5	-15.0	9.1	11.8		120	48.9	170.3	157.7
10	-12.2	12.0	14.6		125	51.7	183.6	169.1
15	-9.4	15.0	17.7		130	54.4	197.6	181.0
20	-6.7	18.4	21.0		135	57.2	212.4	193.5
25	-3.9	22.1	24.6		140	60.0	227.9	206.6
30	-1.1	26.1	28.5		145	62.8	244.3	220.3
35	1.7	30.4	32.6		150	65.6	261.4	234.6
40	4.4	35.0	37.0		155	68.3	279.5	249.5
45	7.2	40.0	41.7		160	71.1	298.4	265.1
50	10.0	45.3	46.7		165	73.9	318.3	281.4

Section 4 Refrigeration

Inhalation Toxicity

HFC-134a poses no acute or chronic hazard when it is handled in accordance with DuPont recommendations and when exposures are maintained at or below the DuPont Acceptable Exposure Limit (AEL) of 1,000 ppm (8 and 12 hour Time-Weighted Average or TWA).

An AEL is an airborne exposure limit established by DuPont scientists that specifies time-weighted average (TWA) airborne concentrations to which nearly all workers may be repeatedly exposed without adverse effects. The AEL for HFC-134a has the same value as the Threshold Limit Values (TLVs) established for CFC-12 and HCFC-22. TLVs are established by the American Conference of Governmental and Industrial Hygienists (ACGIH).

However, inhaling high concentrations of HFC-134a vapor may cause temporary central nervous system depression with narcosis, lethargy and anesthetic effects. Other effects that may occur include dizziness, a feeling of intoxication and a loss of coordination. Continued breathing of high concentrations of HFC-134a vapors may produce cardiac irregularities (cardiac sensitization), unconsciousness, and with gross overexposure, death. Intentional misuse or deliberate inhalation of HFC-134a may cause death without warning. This practice is extremely dangerous.

If you experience any of the initial symptoms, move to fresh air and seek medical attention.

Cardiac Sensitization

If vapors are inhaled at a concentration of 75,000 ppm, which is well above the AEL, the heart may become sensitized to adrenaline, leading to cardiac irregularities and, possibly, to cardiac arrest. The likelihood of these cardiac problems increases if you are under physical or emotional stress.

Medical attention must be given immediately if exposed to high concentrations of HFC-134a. DO NOT treat with adrenaline (epinephrine) or similar drugs. These drugs may increase the risk of cardiac arrhythmia and cardiac arrest. If the person is having difficulty breathing, administer oxygen. If breathing has stopped, give artificial respiration.

Spills or Leaks

If a large release of vapor occurs, such as from a large spill or leak, the vapors may concentrate near the floor or low spots and displace the oxygen available for breathing, causing suffocation.

Evacuate everyone until the area has been ventilated. Use blowers or fans to circulate the air at floor level. DO NOT re-enter the affected area unless you are equipped with a self-contained breathing apparatus or unless an area monitor indicates that the concentration of HFC-134a vapors in the area is below the AEL.

Always use self-contained breathing apparatus or an air-line mask when entering tanks or other areas where vapors might exist. Use the buddy system and a lifeline. Refer to the Material Safety Data Sheet (MSDS) for HFC-134a for more information.

HFC-134a vapors have a slightly sweet odor that can be difficult to detect. Therefore, frequent leak checks and the installation of permanent area monitors may be necessary in enclosed spaces. Refer to ASHRAE Standards 15 and 34 for refrigeration machinery rooms.

To ensure safety when working with HFC-134a in enclosed areas:

1. Route relief and purge vent piping (if present) outdoors, away from air intakes.
2. Make certain area is well ventilated, using auxiliary ventilation if needed to move vapors.
3. Make sure area is clear of vapors prior to beginning work.
4. Install air monitoring equipment to detect leaks.

Skin and Eye Contact

At room temperature, HFC-134a vapors have little or no effect on the skin or eyes. However, in liquid form, HFC-134a can freeze skin or eyes on contact, causing frostbite. Following contact, soak the exposed area in lukewarm water, not cold or hot. If medical treatment cannot begin immediately, apply a light coat of a nonmedicated ointment, such as petroleum jelly. If the exposed area is in a location where the presence of the ointment would be awkward, such as on the eye, apply a light bandage. In all cases of frostbite, seek medical attention as soon as possible.

Always wear protective clothing when there is a risk of exposure to liquid HFC-134a. Where splashing is possible, always wear eye protection and a face shield.

Combustibility of HFC-134a

HFC-134a is nonflammable at ambient temperatures and atmospheric pressure. However, tests have shown HFC-134a to be combustible at pressures as low as 5.5 psi (139.3 kPa absolute) at 177°C (350°F) when mixed with air at concentrations generally greater than 60% volume air. At lower temperatures, higher pressures are required for combustibility. (HCFC-22 is also combustible at pressures above atmospheric in the presence of high air concentrations). Test results and calculations have shown:

- At ambient temperature, all concentrations of HFC-134a in air are nonflammable at pressures below 15 psi (205 kPa absolute).
- Combustible mixtures of air and HFC-134a will not form when liquid HFC-134a is pumped into closed vessel if initial air pressure in vessel is limited to one atmosphere absolute and final pressure is limited to 300 psi (2,170 kPa absolute). If initial air pressure is greater than one atmosphere, combustible mixtures may form as tank is filled.

Based on above information, the following operating practices are recommended:

Leak Testing

- Equipment should NEVER be leak tested with a pressurized mixture of HFC-134a and air. HFC-134a may be safely pressured with dry nitrogen.

Bulk Delivery and Storage

- Tanks should normally be evacuated at start of filling, and should never be filled while under positive air pressure.
- Tank pressure should never be allowed to exceed 300 psi (2,170 kPa) when filling with HFC-134a. Relief devices on either tanks or HFC-134a supply system usually prevent this.
- Tank pressures should be monitored routinely.
- Air lines should never be connected to storage tanks.

Filling and Charging Operations

- Before evacuating cylinders or refrigeration equipment, any remaining refrigerant should be removed by recovery system.
- Vacuum pump discharge lines should be free of restrictions that could increase discharge pressures above 15 psi (205 kPa) and result in formation of combustible mixtures.
- Cylinders or refrigeration equipment should normally be evacuated at start of filling, and should never be filled while under positive air pressure.
- Final pressures should not exceed 300 psi (2,170 kPa).
- Filled cylinders should periodically be analyzed for air (nonabsorbable gas or NAG).

Refrigerant Recovery Systems

Efficient recovery of refrigerant from equipment or containers requires evacuation at the end of the recovery cycle. Suction lines to a recovery compressor should be periodically checked for leaks to prevent compressing air into the recovery cylinder during evacuation. In addition, the recovery cylinder pressure should be monitored, and evacuation stopped in the event of a rapid pressure rise indicating the presence of noncondensable air. The recovery cylinder contents should then be analyzed for NAG, and the recovery system leak checked if air is present. DO NOT continue to evacuate a refrigeration system that has a major leak.

Thermal Decomposition

HFC-134a vapors will decompose when exposed to high temperatures from flames or electric resistance heaters. Decomposition may produce toxic and irritating compounds, such as hydrogen fluoride. The pungent odors released will irritate the nose and throat and generally force people to evacuate the area. Therefore, it is important to prevent decomposition by avoiding exposure to high temperatures.

Component Teardown

This section explains how to access and remove components from an Upright Frigidaire Freezer, and has been arranged in such a way as to simulate which components would need to be removed first in order to gain access to other components. When following a component removal procedure, it may be necessary to reference another component removal procedure listed earlier in this section.

IMPORTANT

Before continuing, please take note of the WARNINGS and CAUTIONS below.

WARNING

- **If it is necessary to remove a Freezer unit from its installation, use proper lifting techniques as units are heavy and could fall resulting in serious injury or death. Pulling a unit from its installation should only be performed by a trained authorized service technician or installer.**
- **To avoid electric shock, power to a freezer unit must be disconnected whenever accessing/ removing components powered by electricity or components near other electrical components.**
- **After service is completed, be sure all safety-grounding circuits are complete, all electrical connections are secure, and all access panels are in place.**
- **If unit was used prior to service, the Compressor assembly will be hot. Wear protective gloves and the appropriate safety gear when working with compressors.**
- **If removing a door or drawer from a unit, remember that the doors and drawers are heavy. If they were to fall, they could cause serious personal injury.**

CAUTION

- **Metal edges may be sharp. Use caution and wear appropriate safety equipment when servicing evaporators and condensers to avoid personal injury.**
- **If working in the compressor area, remember that compressor and tubing may be hot.**

Section 5 Component Teardown

Exterior Components

Door Handle

The door handle is secured to the door assembly with two screw and button assemblies that slide behind a dovetail block inside the handle assembly and with screws on each end of the handle. Two screw cover plates slide over the door handle to hide the door handle mounting screws. (See Figure 5-1)

To remove the door handle:

1. Remove screw cover plates by pushing in and sliding the screw cover plate off of the door handle.
2. Using a phillips head screwdriver, extract the screws securing the door handle to the door assembly.
3. Push upwards until the screw button assembly is free of the dovetail inside the handle assembly.

Kickplate Removal

The kickplate is secured with two screws to the lower front of the unit.

To remove the kickplate, extract the screw from each end of the kickplate with a phillips head screwdriver. (See Figure 5-2)

Door Hinge and Door Assembly Removal

The door assembly is secured to the unit frame by an upper and lower hinge assembly. The wiring harness leading out of the door assembly must be disconnected from the wire harness in the compressor area before the door assembly can be removed.

To remove the door assembly:

1. Gently lay freezer on its back on a soft clean surface.
2. Lift plastic cover off upper hinge assembly. (See Figure 5-3)
3. Using a T27 tamper proof Torx bit, extract screws securing the upper hinge to the unit frame.
4. Remove kickplate.
5. Reach under bottom of cabinet and disconnect wire leads of door connector from the cabinet connector. (See Figure 5-4)
6. Using a T27 tamper proof Torx bit, extract screws securing the lower hinge to the unit frame. Use a phillips head screwdriver to extract the remaining screw from the lower hinge assembly.
7. Lift the door assembly off of the unit frame.

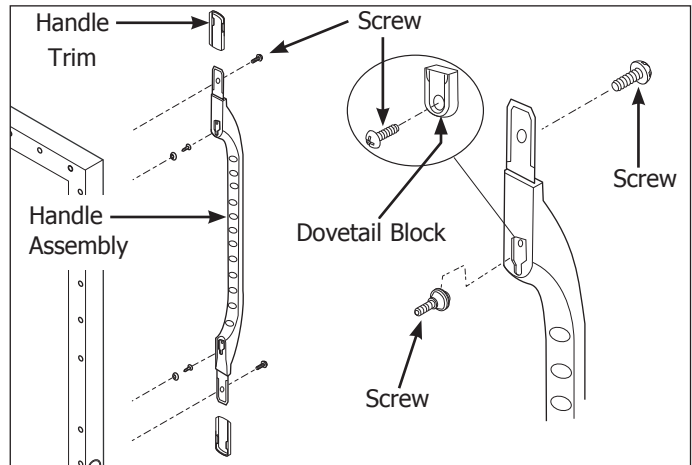

Figure 5-1. Handle Removal

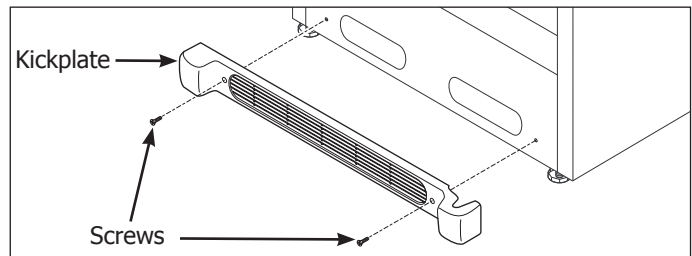

Figure 5-2. Kickplate Removal

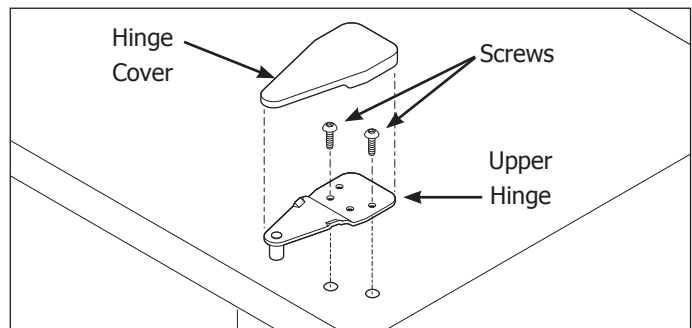

Figure 5-3. Upper Hinge Removal

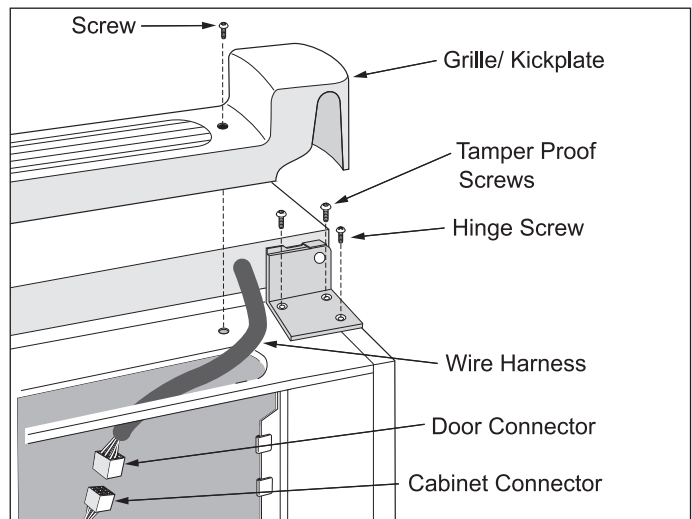

Figure 5-4. Lower Hinge Removal

Section 5 Component Teardown

Door Stop Assembly Removal

The door stop is secured to with two screws the underside of the door assembly.

To remove the door stop:

1. Remove door from unit.
2. Extract the two screws securing the door stop to the bottom of the door assembly. (See Figure 5-5)

Door Gasket and Inner Panel Removal

The inner panel of the door assembly is secured with screws that pass through the inner panel and fasten into the door assembly. The door gasket has an inner lip that is pressed between the inner panel and the door assembly and is secured in position when the inner panel screws are fastened to the door assembly. The inner panel does not have to be removed to extract the door gasket from the door assembly.

To remove the door gasket:

1. Lift the inside edge of the door gasket to access the inner panel screws.
2. Loosen the inner panel screws until the door gasket can be pulled out from under the inner panel. (See Figure 5-6)
3. Continue loosening screws around door assembly until door gasket is free.
4. To remove the inner panel, extract all screws from the outside edge of the inner panel and remove from unit.

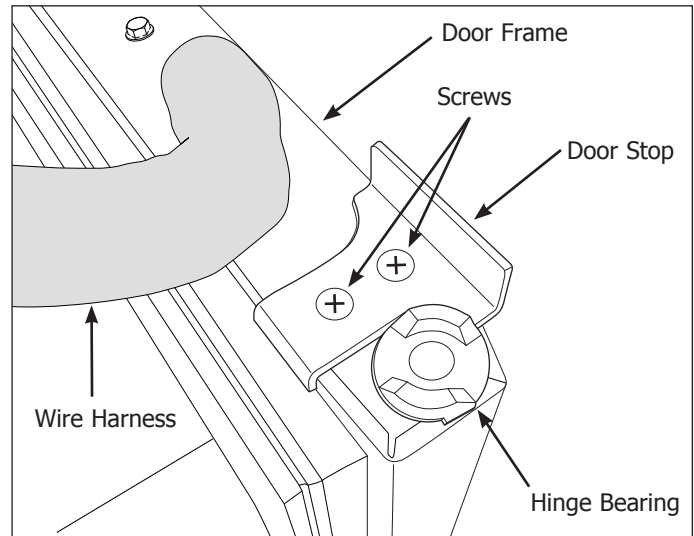

Figure 5-5. Door Stop Removal

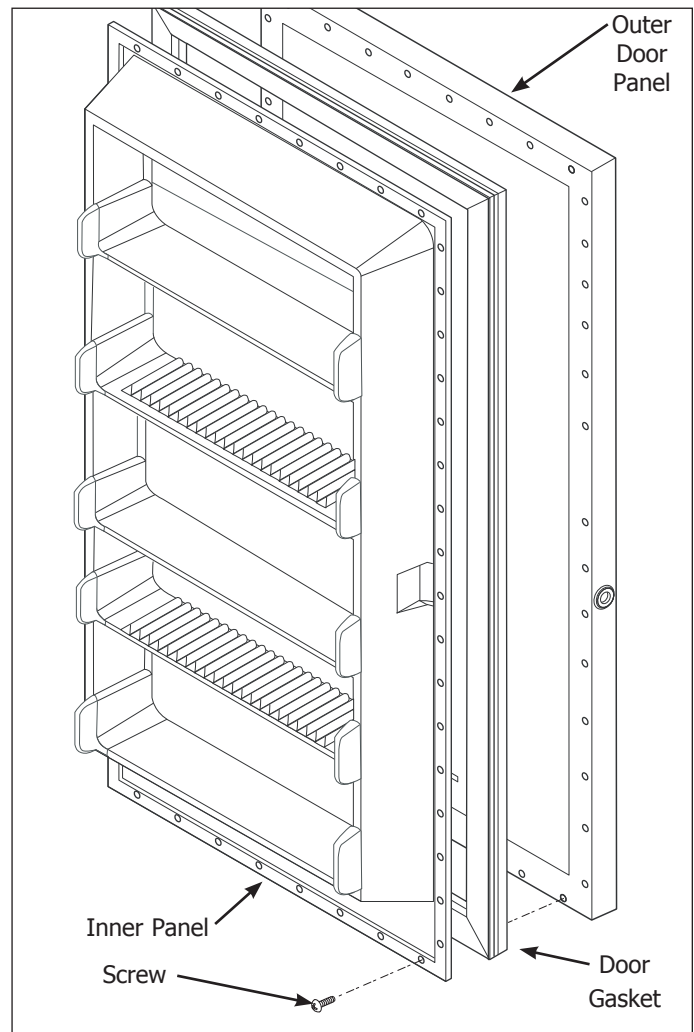

Figure 5-6. Inner Panel and Door Gasket Removal

Section 5 Component Teardown

Door Lock Removal

The door lock assembly is secured to the door assembly with a locking fork located inside the outer door panel. The inner panel must be removed first to access the lock assembly.

To remove the lock assembly (See Figure 5-7):

1. Carefully remove enough foam from inside outer door panel to gain access to the locking fork.
2. Use a flat-bladed screwdriver to push up on the locking fork until it disengages the lock mechanism.
3. Pull lock assembly out of door liner.
4. When re-installing, replace foam around locking fork.

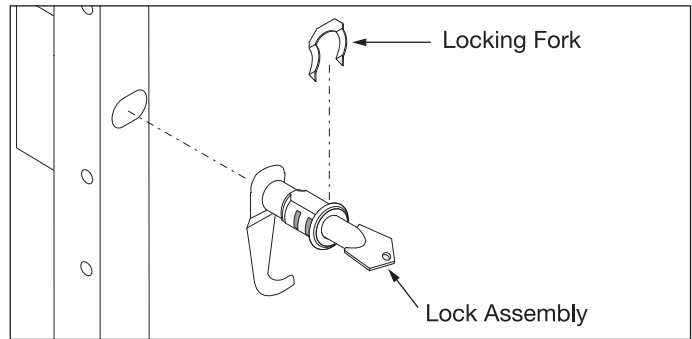

Figure 5-7. Door Lock Removal

EZ Set Control Assembly Removal

The EZ Set control assembly is mounted inside the front of the door assembly and is secured in position with retaining latches. The electronic board is secured to the inside of the bezel with retaining latches.

To remove the EZ Set control assembly:

1. Disconnect power to freezer.
2. Using a small flat bladed screwdriver, carefully pry under the bezel until the retaining latches release from the door assembly. Pull control assembly straight out to avoid damaging the electrical connection wire prongs. (See Figure 5-8)

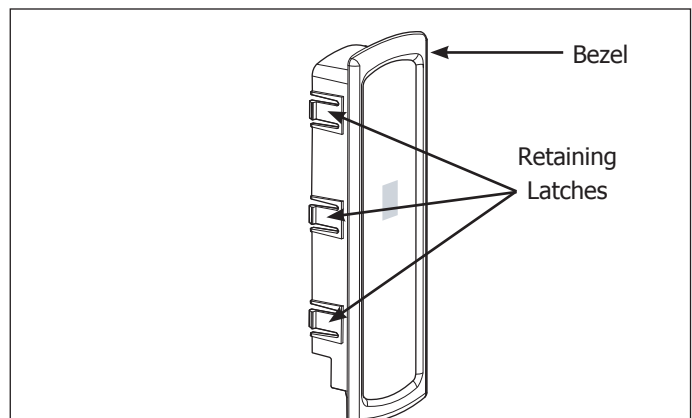

Figure 5-8. EZ Set Control Removal

Precision Set Control Assembly Removal

The Precision Set control assembly is mounted inside the front of the door assembly and is secured in position with retaining latches.

To remove the Precision Set control assembly:

1. Disconnect power to freezer.
2. Using a small flat bladed screwdriver or equivalent tool (See Figure 5-9), carefully pry under the bezel until the retaining latches release from the door assembly. Pull control assembly straight out to avoid damaging the electrical connection wire prongs.

To install the Precision Set control assembly:

1. Push control in gently with the palm of your hand. You may need to slightly adjust the bezel position up or down to align connector pins.
2. Gently push control flush to door with palm of hand.

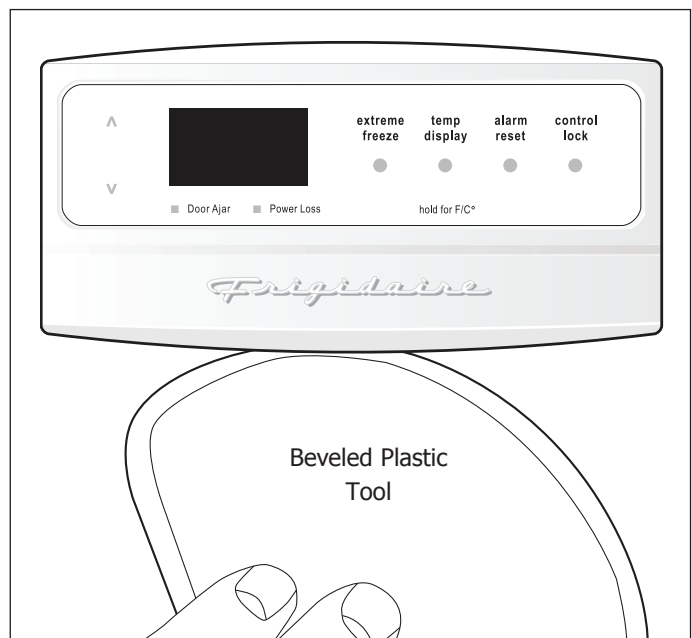

Figure 5-9. Precision Set Control Removal

Section 5 Component Teardown

Door Shelf Guard Removal

The door shelf guard is secured to the inner door panel with two tabs on each end.

To remove the door shelf guard, bend the door shelf guard out in the middle while bending out the outer portion of the inner panel outwards, then pull the tabs of the door shelf guard out of the inner panel. (See Figure 5-10)

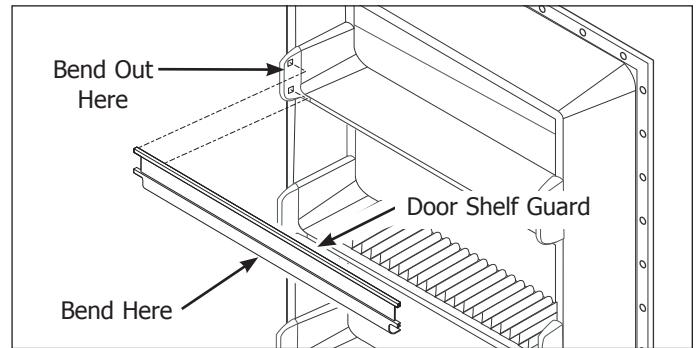

Figure 5-10. Door Shelf Guard Removal

Door Switch Removal

The door switch is mounted inside a hole in the cabinet base along the lower left hand side. (See Figure 5-11)

To remove the door switch:

1. Remove kickplate.
2. Reach under cabinet frame and disconnect the electrical leads from the door switch terminals.
3. Press in on the retaining latch on the switch body and push switch through hole in cabinet base.

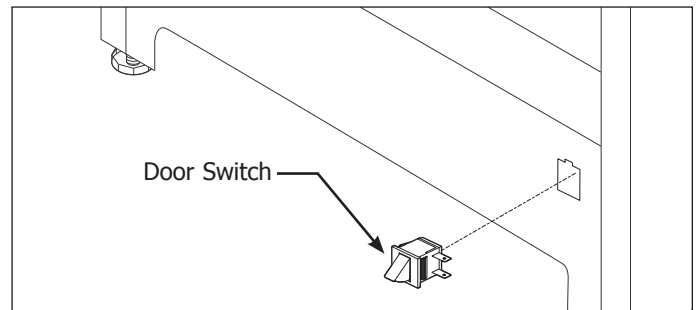

Figure 5-11. Door Switch Removal

Interior Components

Shelf Assembly

The shelf assemblies have metal bars that slide into holes in the cabinet interior liner walls. Rubber bumpers are attached to the metal bars to prevent side to side movement within the cabinet. (See Figure 5-12)

To remove the shelf assemblies:

1. Remove rubber bumpers from right side of shelf assembly.
2. Remove shelf assembly by pushing to the right until the metal bars are free from the left side liner wall. Then tilt down or up until the shelf can be removed from the right side liner wall.

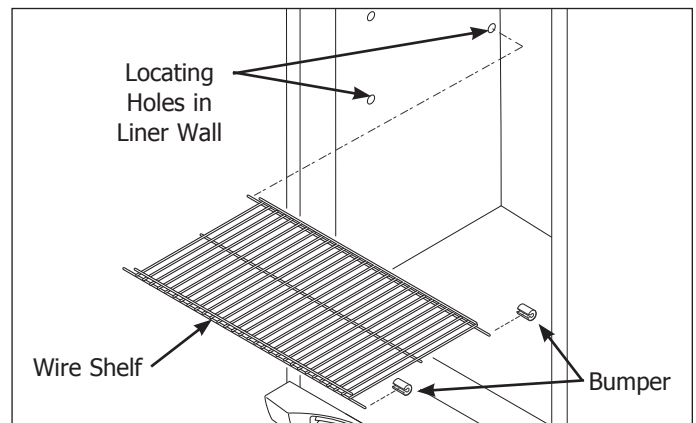

Figure 5-12. Shelf Assembly Removal

Wire Basket Removal

The wire basket slides under the basket stops mounted to the compartment side walls. Plastic basket glides clipped onto the wire basket allow the wire basket to slide on the freezer compartment floor. (See Figure 5-13)

To remove the wire basket, simply pull out from under the basket stops and remove from the unit.

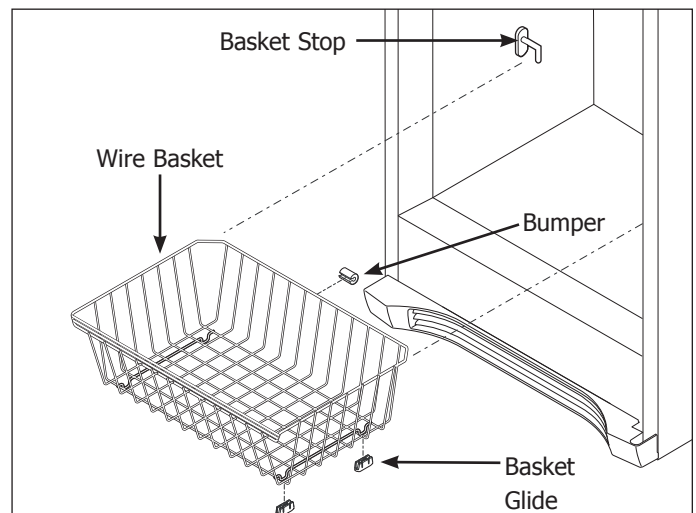

Figure 5-13. Wire Basket Removal

Section 5 Component Teardown

Light Shield Removal

The light shield is secured with retaining tabs that locate in slots cut in the interior cabinet ceiling.

(See Figure 5-14)

To remove the light shield, grab the light shield and push in near the retaining tabs until the retaining tabs release from the slots in the compartment ceiling.

Light Fixture Removal

The light fixture is secured with retaining latches into the interior cabinet ceiling behind the light shield.

(See Figure 5-15)

To remove the light fixture:

1. Remove light bulb by turning counter-clockwise.
2. Pull down on the front of the light fixture while turning the fixture a quarter turn to release the retaining latches.
3. Disconnect wire leads from light fixture terminals.

Baffle Plate Removal

The baffle plate is secured with four retaining latches to slots in the compartment upper back wall.

(See Figure 5-15)

To remove the baffle plate, with one hand grab the baffle plate from the center and pull back while with the other hand, reach behind to disengage the retaining latches.

Evaporator Cover Removal

The evaporator cover is secured with screws to the back wall and bottom of the freezer compartment. The evaporator cover has a gasket on each side to create proper airflow in the compartment. (See Figure 5-16)

To remove the evaporator cover:

1. Remove the bottom two shelf assemblies.
2. Remove the wire basket.
3. Using a phillips head screwdriver, extract the ten (10) screws securing the evaporator cover to the freezer compartment.
4. Carefully pull the evaporator cover away from the back wall, using caution not to damage the gaskets on both sides of the evaporator cover.

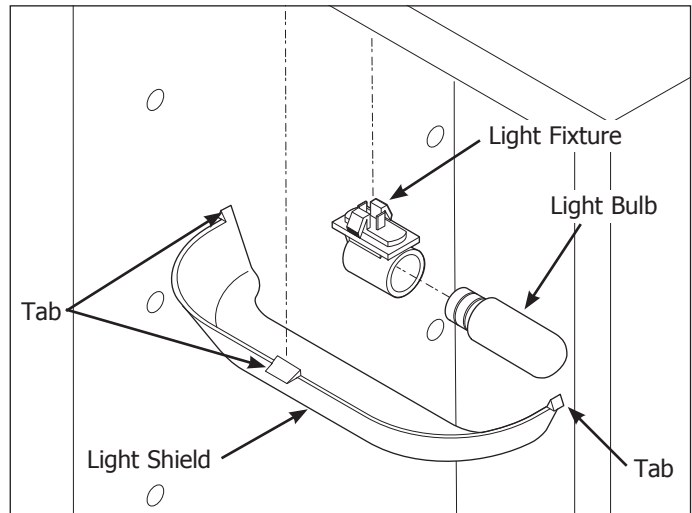

Figure 5-14. Light Shield and Fixture Removal

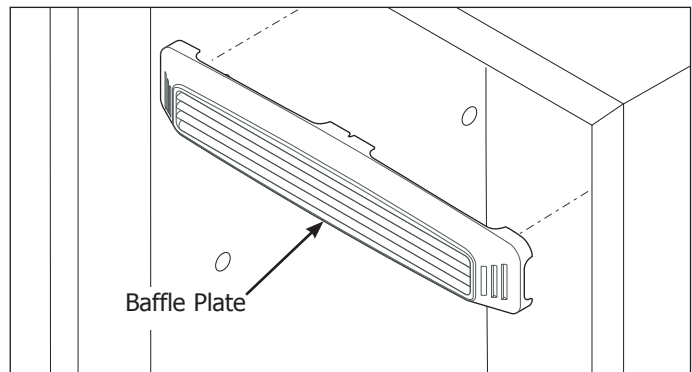

Figure 5-15. Baffle Plate Removal

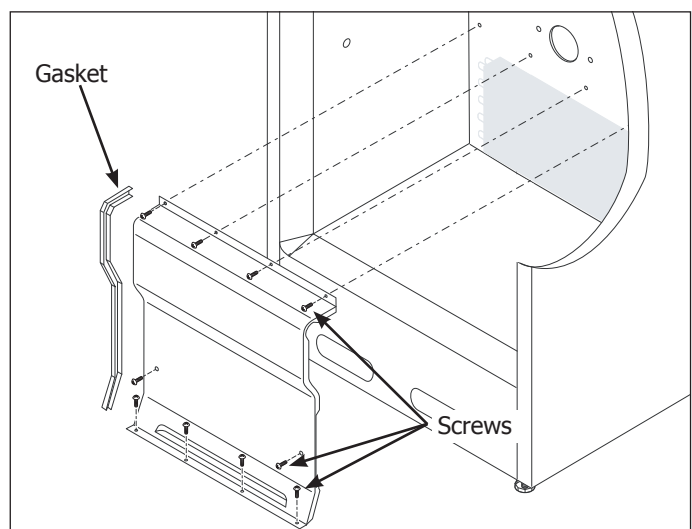

Figure 5-16. Evaporator Cover Removal

Section 5 Component Teardown

Evaporator Fan Assembly Removal

The evaporator fan assembly consists of the fan motor mount bracket, fan motor and fan blade. Two screws secure the fan motor to the fan motor mount bracket. The evaporator fan assembly is then secured with two screws to the back wall of the freezer compartment. (See Figure 5-17)

To remove the evaporator fan assembly:

1. Remove the bottom two shelf assemblies.
2. Remove wire basket.
3. Remove the evaporator cover.
4. Remove wires from retaining clips. Disconnect the electrical leads of fan motor at quick disconnect.
5. Using a 5/16" socket or nut driver, extract the two hex head screws securing the fan motor mounting bracket to the back wall of the unit.
6. Separate the fan motor from the mounting bracket by extracting the two hex head screws securing the fan motor to mounting bracket.
7. Pull fan blade from fan motor shaft.

Defrost Thermostat Removal

The defrost thermostat is secured with a retaining clip to the evaporator outlet tube located on the upper left corner of the evaporator assembly. (See Figure 5-19)

To remove the defrost thermostat:

1. Remove the bottom two shelf assemblies.
2. Remove wire basket.
3. Remove the evaporator cover.
4. Disconnect the defrost thermostat wire leads from the wire harness. (See Figure 5-18)
5. Pull the defrost thermostat off of the evaporator outlet tubing.

Thermistor Removal

The thermistor is mounted with a screw to the back wall of the freezer compartment behind the evaporator cover.

To remove the thermistor:

1. Remove the evaporator cover.
2. Extract the phillips screw securing the thermistor to the back wall. (See Figure 5-19)
3. Cut the wires and splice the new thermistor into wire harness.

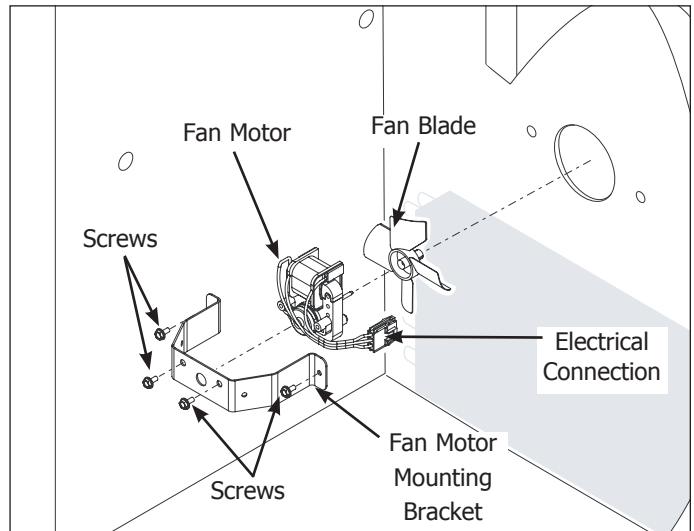

Figure 5-17. Evaporator Fan Assembly Removal

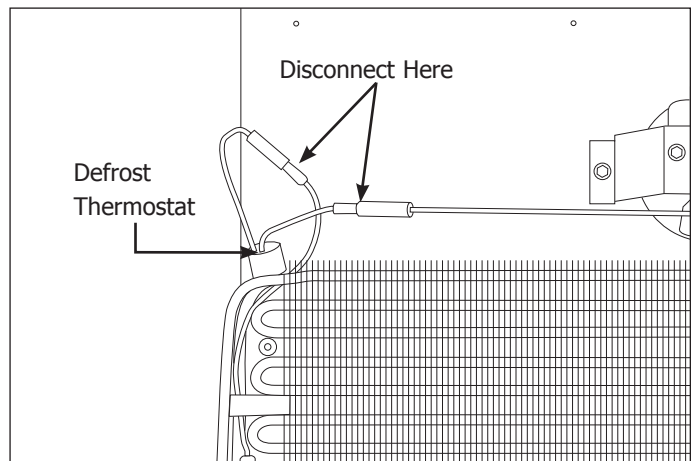

Figure 5-18. Defrost Thermostat Removal

NOTE

Freezer defrost thermostat must be installed on the evaporator outlet tubing.

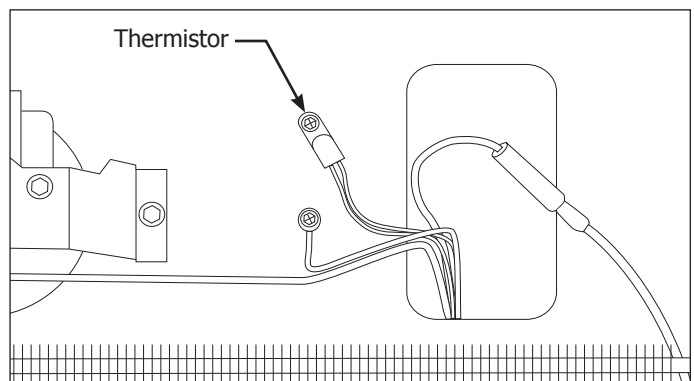

Figure 5-19. Defrost Thermostat Removal

Section 5 Component Teardown

Defrost Heater Removal

The defrost heater is secured with two aluminum straps to the bottom tube of the evaporator assembly. (See Figure 5-20)

To remove the defrost heater:

1. Remove the bottom two shelf assemblies.
2. Remove wire basket.
3. Remove the evaporator cover.
4. Disconnect the defrost heater wire leads from the wire harness. (See Figure 5-20)
5. Release the aluminum straps securing the defrost heater to the bottom of the evaporator assembly.
6. Remove the styrofoam insulators from both sides of the evaporator.
7. Pull defrost heater from evaporator assembly.

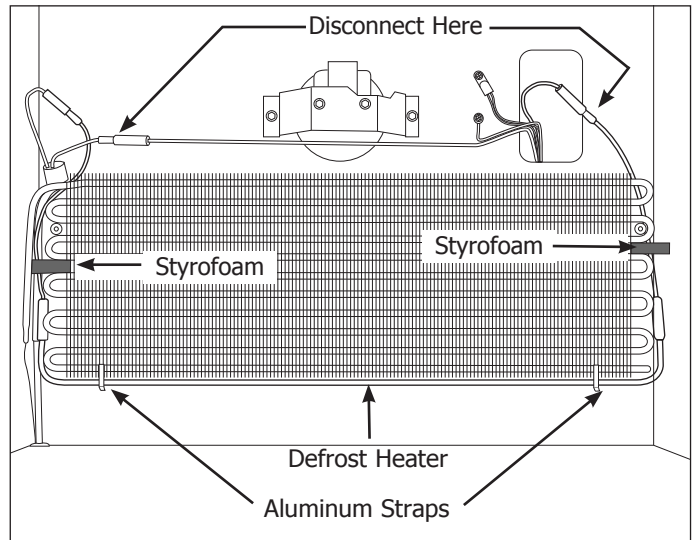

Figure 5-20. Defrost Heater Removal

Evaporator Removal

The evaporator sets upon the two screw standoffs mounted to the back wall of the freezer compartment. Two pieces of styrofoam are pressed between the evaporator assembly and the sidewalls of the unit, securing the assembly in position. (See Figure 5-21)

To remove the evaporator:

1. Remove the bottom two shelf assemblies.
2. Remove wire basket.
3. Remove the evaporator cover.
4. Remove the styrofoam insulators from both sides of the evaporator.
5. Remove the defrost thermostat and defrost heater.
6. Recover refrigerant by using EPA approved recovery system.

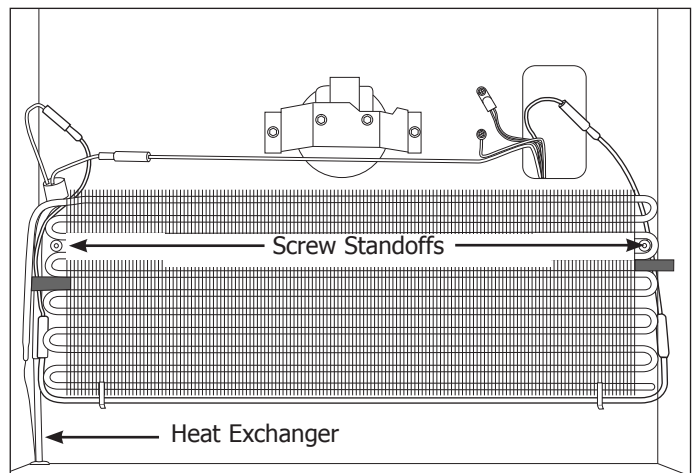

Figure 5-21. Evaporator Removal

NOTE

Whenever the sealed system is opened the filter-drier must be replaced.

7. Remove the filter-drier.
8. Cut suction line about 1" from compressor.
9. Straighten the tubing, remove the foam sleeve, and carefully feed the heat exchanger through the cabinet while pulling up on the evaporator.

Section 5 Component Teardown

Compressor Area Components

Power Cord Removal

The power cord enters the compressor area on the lower left side and is secured to the compressor mounting plate with a P-clamp and screw.

To remove the power cord:

1. Pull unit from its installation position to access the rear compressor area.
2. Using a phillips head screwdriver, extract the four screws securing the compressor area shield to the rear of the unit. Remove shield.
3. Using a 1/4" socket or wrench, extract the screw securing the P-clamp to the compressor mounting plate. (See Figure 5-22)
4. Using a 1/4" socket or wrench, extract the screw securing the ground wires to the compressor mounting plate.
5. Disconnect power cord from the wire harness at the quick disconnect. Remove power cord from unit.

Filter-Drier Removal

The filter-drier is located in the compressor area on the left side of the compressor. (See Figure 5-23)

To remove the filter-drier:

1. Pull unit from its installation position.
2. Extract the screws securing the fiber board cover to the unit frame and remove from unit.
3. Recover refrigerant by using EPA approved recovery system.
4. Using a 3 cornered file, score a groove around capillary tube as close to old filter-drier as possible. Break capillary tube along score mark from filter-drier.
5. Cut condenser outlet tube at filter-drier. Discard filter-drier.
6. Thoroughly clean condenser outlet tube and capillary tube.
7. Place inlet connection of filter-drier over condenser tube approximately 1/4" and solder.
8. Insert capillary tube input end into filter-drier outlet. Do not allow tube to bottom against screen. Solder carefully so that solder does not plug capillary tube.
9. Install process tube adapter to filter-drier.
10. Evacuate and charge system using the recommended procedure described under Evacuating and Recharging in the Refrigeration section.
11. Reassemble unit.

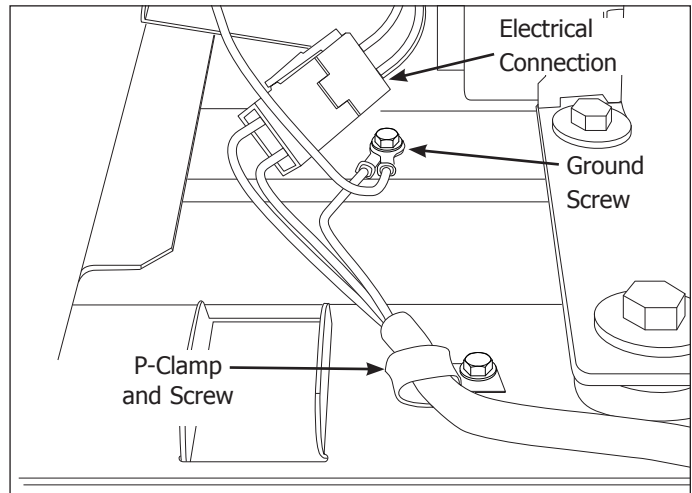

Figure 5-22. Power Cord Removal

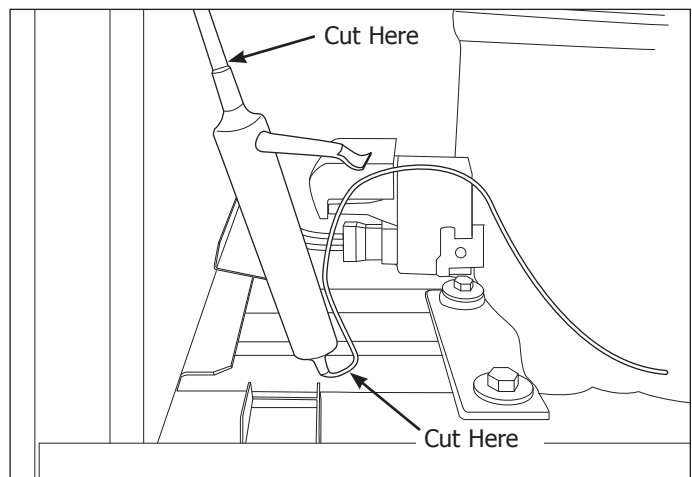

Figure 5-23. Filter-Drier Removal

CAUTION

On R-134a systems, the system must NOT be left open to the atmosphere for more than 10 minutes to prevent moisture contamination of compressor oil.

Section 5 Component Teardown

Drain Pan

The drain pan is mounted to a bracket mounted to the top of the compressor. (See Figure 5-24)

To remove the drain pan:

1. Pull unit from its installation position.
2. Extract the screws securing the fiber board cover to the unit frame and remove from unit.
3. Using a pliers, remove the retaining clip securing the drain pan to the top of the compressor.
4. Pull drain pan off compressor, remove drain hose and remove from unit.

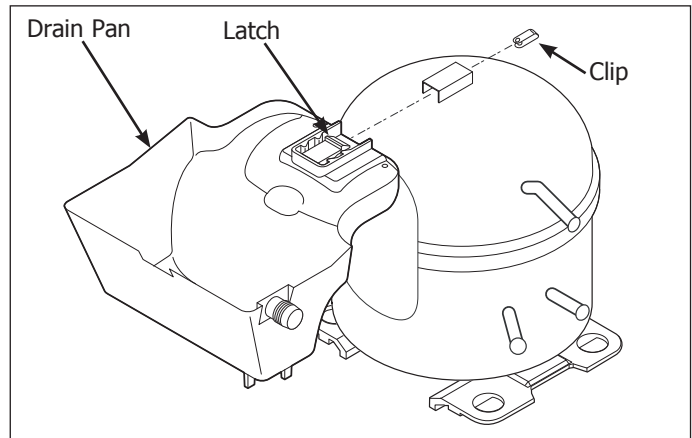

Figure 5-24. Drain Pan Removal

Compressor Removal

The compressor sits on four grommets and is secured with four screws to the compressor mounting plate. (See Figure 5-25 & 5-26)

To remove the filter-drier:

1. Pull unit from its installation position.
2. Extract the screws securing the compressor shield to the unit frame and remove from unit.
3. Using a small flat bladed screwdriver, release the locking tab from the wire harness connection and disconnect from compressor controller.
4. Using a needlenose pliers, remove spring wire holding the controller to the compressor.
5. Recover refrigerant by using EPA approved recovery system.
6. Using a 7/16" socket, remove the (4) bolts, one in each corner, holding the compressor to the base. (See Figure 5-26)
7. After refrigerant is completely recovered, cut suction and discharge lines as close to compressor as possible. Leave only enough tubing to pinch off and seal defective compressor. Plug or tape any open system tubing to avoid entrance of moisture and air into system. Remove inoperable compressor and transfer mounting parts to new compressor.
8. Install new compressor in exact same manner as original compressor.
9. Reform both suction and discharge lines to align with new compressor. If they are too short, use additional lengths of tubing. Joints should overlap 0.5" to provide sufficient area for good solder joint. Clean and mark area where tubing should be cut.
10. Cut tubing with tubing cutter. Work quickly to avoid letting moisture and air into system.
11. Reassemble unit.

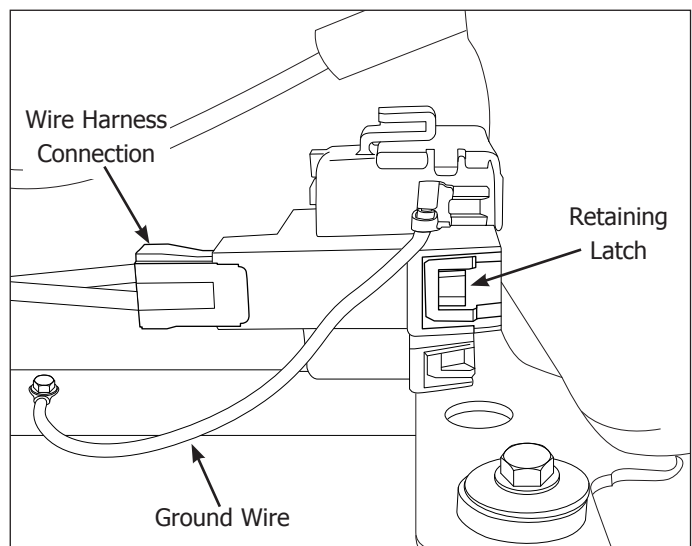

Figure 5-25. Compressor Electrical Component Removal

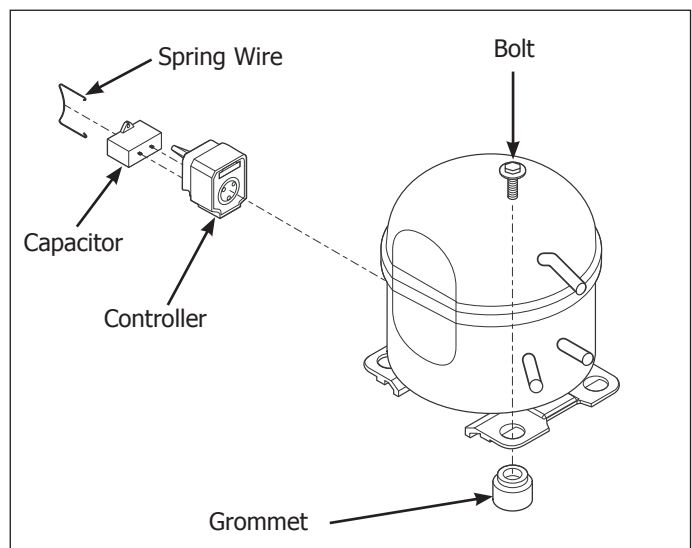

Figure 5-26. Compressor Components

Condenser Service

The condenser is foamed in place and is not accessible for repair. However, repair can be made by installing a service replacement condenser kit. Refer to the part list of the model being serviced for the correct kit part number.

Each service replacement condenser kit consists of: a condenser assembly that can be installed on the back of the cabinet, mounting hardware, replacement filter-drier and a complete installation instructions.

To install, use the following procedure:

1. Disconnect unit from source of power.
2. Recover refrigerant by using EPA approved recovery system.
3. Installed the replacement condenser in accordance with the instructions included with the kit.
4. Evacuate and charge a system using the recommended procedure described under evacuation and recharging found in section 4.

Section 6 Troubleshooting

Problem	Cause	Correction
Freezer compressor does not run.	Freezer is plugged into a circuit that has a ground fault interrupt.	Use another circuit. Check circuit for proper voltage.
	Temperature control is in the "OFF" position.	Unplug from AC power, wait a minute then plug nit into AC power outlet. Instruct customer.
	Freezer may not be plugged in, or plug may be loose.	Ensure plug is tightly pushed into outlet.
	House fuse blown or tripped circuit breaker.	Check/replace fuse with a 15 amp time delay fuse. Reset circuit breaker.
	Power outage.	Check house lights. Call local Electric Company.
Freezer runs too much or too long.	Room or outside weather is hot.	It's normal for the Freezer to work harder under these conditions.
	Freezer has recently been disconnected for a period of time.	It takes 24 hours for the Freezer to cool down completely.
	Large amount of warm or hot food have been stored recently.	Warm food will cause Freezer to run more until the desired temperature is reached.
	Door is opened too frequently or kept open too long.	Warm air entering the Freezer causes it to run more. Open the door less often.
	Freezer door may be slightly open.	See Problem section "Door will not close".
	Temperature control is set too low.	Set control to a warmer setting. Allow several hours for the temperature to stabilize.
	Freezer gaskets are dirty, worn, cracked or poorly fitted.	Clean or change gasket. Leaks in the door seal will cause Freezer to run longer in order to maintain desired temperature.
	Interior Freezer temperature is too cold.	Temperature control is set too low.
Interior Freezer temperature is too warm.	Temperature control is set too warm.	Set control to a colder setting. Allow several hours for the temperature to stabilize.
	Door is opened too frequently or kept open too long.	Warm air entering the Freezer causes it to run more. Open the door less often.
	Freezer door may be slightly open.	See Problem section "Door will not close".
	Large amount of warm or hot food have been stored recently.	Wait until the Freezer has had a chance to reach its selected temperature.
	Freezer has recently been disconnected for a period of time.	Freezer requires 24 hours to cool down completely.
Freezer external surface temperature is warm.	The external Freezer walls can be as much as 30°F warmer than room temperature.	This is normal while the compressor works to transfer heat from inside the Freezer cabinet.

Section 6 Troubleshooting

Problem	Cause	Correction
Louder sound levels whenever Freezer is on.	Modern Freezers have increased storage capacity and more stable temperatures. They require heavy duty compressors.	This is normal. When the surrounding noise level is low, you might hear the compressor running while it cools the interior.
Louder sound levels when compressor comes on.	Freezer operates at higher pressures during the start of the ON cycle.	This is normal. Sound will level off or disappear as Freezer continues to run.
Popping or cracking sound when compressor comes on.	Metal parts undergo expansion and contraction, as in hot water pipes.	This is normal. Sound will level off or disappear as Freezer continues to run.
Bubbling or gurgling sound.	Refrigerant used to cool Freezer is circulating throughout system.	This is normal.
Vibrating or rattling noise.	Freezer is not level. It rocks on the floor when it is moved slightly.	Level the Freezer.
	Floor is uneven or weak.	Ensure floor can adequately support Freezer. Level the Freezer by putting wood or metal shims under part of the Freezer.
	Freezer is touching the wall.	Re-level Freezer or move Freezer slightly.
Moisture forms on inside Freezer walls.	Weather is hot and humid, which increases internal rate of frost build-up.	This is normal.
	Door is slightly open.	See Problem section "Door will not close".
	Door is opened too frequently or kept open too long.	Open the door less often.
Odors in Freezer.	Interior needs to be cleaned.	Clean interior with sponge, warm water, and baking soda. Replace air filter.
	Foods with strong odors are in the Freezer.	Cover the food tightly.
Door will not close.	Freezer is not level. It rocks on the floor when it is moved slightly.	This condition can force the cabinet out of square and misalign the door. Level unit.
	Floor is uneven or weak.	Ensure floor can adequately support Freezer. Level the Freezer by putting wood or metal shims under part of the Freezer.
Light bulb is not on.	The fluorescent lamp or light bulb is burned out.	Replace lamp or light bulb.
	No electric current is reaching the Freezer.	See Problem section "Freezer compressor does not run" on previous page.

Section 6 Troubleshooting

The following table relates to troubleshooting the electronic control and associated components.

Problem	Cause	Correction
Compressor and evaporator fan motor does not run.	<ol style="list-style-type: none"> 1. Do any of the LED's on the control illuminate? 2. Is the temperature control set to off? 3. Measure the input voltage to the electronic control. Is line to neutral voltage being applied? 4. Disconnect the wiring harness from the compressor controller and measure the voltage drop between the two wires in the harness. Does the meter read line to neutral voltage? 	<p>Yes. Go to step 2. No. Check power to freezer and make sure unit is plugged in.</p> <p>Yes. Set control from 1 to 7 No. Go to step 3.</p> <p>Yes. Replace defective electronic control. No. Defective wire harness.</p> <p>Yes. Replace defective compressor controller or compressor and evaporator fan motor. No. Replace defective electronic control.</p>
Compressor does not run, but the evaporator fan motor does.	<ol style="list-style-type: none"> 1. Defective compressor or compressor controller. 	Replace compressor controller. If problem is not corrected replace compressor.
Evaporator fan motor does not run, but the compressor operates.	<ol style="list-style-type: none"> 1. Is there something blocking the fan blade? 	<p>Yes. Remove restriction from fan blade. No. Replace defective fan motor.</p>
Electronic control display does not illuminate, but the freezer operates.	<ol style="list-style-type: none"> 1. Defective electronic control. 	Replace defective electronic control.
The electronic control does not respond when the upper or down arrows are pushed.	<ol style="list-style-type: none"> 1. Is the control set to Off? 	<p>Yes. The down arrow must be pushed (3) times to advance the control from "Off" to "10°F". No. Replace defective electronic control.</p>
Interior light does not glow when door is opened.	<ol style="list-style-type: none"> 1. Check the light bulb with an ohmmeter. Is the bulb good? 	<p>Yes. Replace defective door switch. No. Replace light bulb.</p>
Compressor runs continuously, but freezer is not cold.	<ol style="list-style-type: none"> 1. Connect a low side gauge to the processing tube on the compressor. Is the pressure in a vacuum or lower than normal? 	<p>Yes. System low on refrigerant, check for leak in system before adding refrigerant. No. Replace defective compressor.</p>
Compressor runs continuously and the freezer is too cold.	<ol style="list-style-type: none"> 1. Defective electronic control. 	Replace defective electronic control.
Freezer temperatures do not correspond with temperature control settings, but compressor operation is normal.	<ol style="list-style-type: none"> 1. Defective electronic control. 	Replace defective electronic control.

Section 6 Troubleshooting

Problem	Cause	Correction
Freezer does not automatically defrost.	<ol style="list-style-type: none"><li data-bbox="414 262 881 325">1. Program the control for a manual defrost. Does the defrost operate?<li data-bbox="414 336 881 535">2. Disconnect the orange wire from the defrost thermostat and the white wire from the defrost heater. Measure the resistance between the wire on the thermostat and the wire at the end of the heater. Is the reading about 25 omhs?<li data-bbox="414 556 881 682">3. Disconnect defrost thermostat from the defrost heater and measure the resistance of the defrost heater. Is the reading about 25 omhs?	<p data-bbox="917 262 1258 325">Yes. Replace electronic control. No. Go to step 2.</p> <p data-bbox="917 336 1258 399">Yes. Replace electronic control. No. Go to step 3.</p> <p data-bbox="917 556 1274 619">Yes. Replace defrost thermostat. No. Replace defrost heater.</p>

Section 7 Wiring Diagram

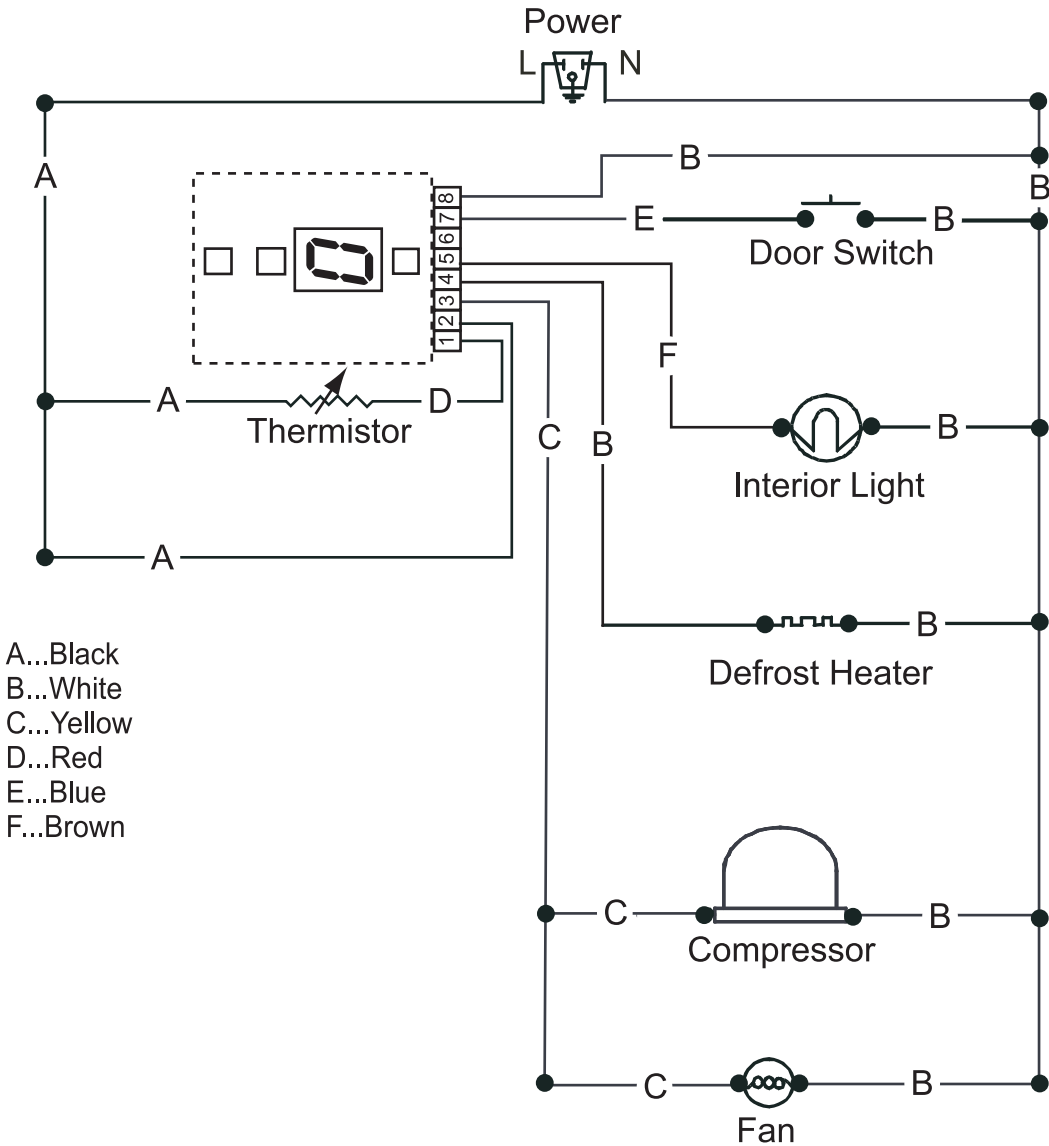

- A...Black
- B...White
- C...Yellow
- D...Red
- E...Blue
- F...Brown

PN 297246001

