

Wine Cooler & Beverage Center Service Manual

with Addendum added for Refrigerator Drawers

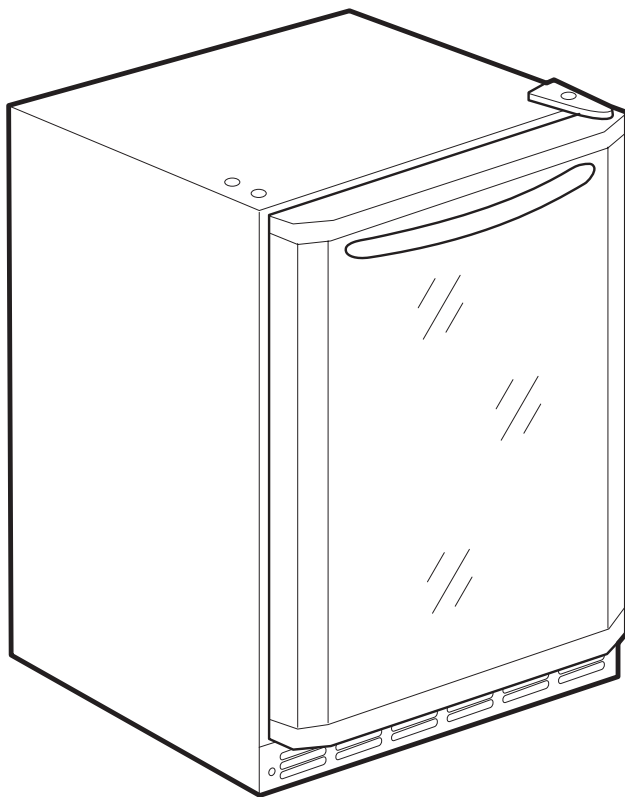

 **Electrolux**

SAFE SERVICING PRACTICES - ALL APPLIANCES

To avoid personal injury and/or property damage, it is important that **Safe Servicing Practices** be observed. The following are some limited examples of safe practices:

1. **DO NOT** attempt a product repair if you have any doubts as to your ability to complete it in a safe and satisfactory manner.
2. Before servicing or moving an appliance:
 - Remove the power cord from the electrical outlet, trip the circuit breaker to the OFF position, or remove the fuse.
 - Turn off the gas supply.
 - Turn off the water supply.
3. Never interfere with the proper operation of any safety device.
4. **USE ONLY REPLACEMENT PARTS CATALOGED FOR THIS APPLIANCE. SUBSTITUTIONS MAY DEFEAT COMPLIANCE WITH SAFETY STANDARDS SET FOR HOME APPLIANCES.**
5. **GROUNDING:** The standard color coding for safety ground wires is **GREEN**, or **GREEN** with **YELLOW STRIPES**. Ground leads are not to be used as current carrying conductors. It is **EXTREMELY** important that the service technician reestablish all safety grounds prior to completion of service. Failure to do so will create a hazard.
6. Prior to returning the product to service, ensure that:
 - All electrical connections are correct and secure
 - All electrical leads are properly dressed and secured away from sharp edges, high-temperature components, and moving parts
 - All non-insulated electrical terminals, connectors, heaters, etc. are adequately spaced away from all metal parts and panels
 - All safety grounds (both internal and external) are correctly and securely connected
 - All panels are properly and securely reassembled

ATTENTION!!!

This service manual is intended for use by persons having electrical and mechanical training and a level of knowledge of these subjects generally considered acceptable in the appliance repair trade. Electrolux Home Products cannot be responsible, nor assume any liability, for injury or damage of any kind arising from the use of this manual.

Table of contents

Safe Servicing Practices - All Appliances	2
A - Installation	
Important safety instructions.....	4
General Precautions.....	4
Installing the Wine Cooler/Beverage Center	5
Site Preparation.....	6
Reversing the Doors.....	7
B - Maintenance	10
Maintaining your Wine Cooler/Beverage Center.....	10
Exterior Cleaning for your Stainless Steel Model.....	10
Interior Cleaning - as Required.....	10
Wine Rack Removal/Installation	10
Glass Shelf Removal/Installation (Beverage Center Only).....	11
Method 1.....	11
Method 2.....	11
C - Electrical Components / Operation	12
Electrical Grounding	12
Compressor Electrical Components and Circuits.....	12
Solid State Relay	12
To Check/Replace Relay	13
Overload Protector	13
To Check/Replace Overload Protector	13
Run Capacitor.....	13
To Check/Replace Run Capacitor.....	13
Compressor Start Circuit.....	14
Compressor Run Circuit.....	14
Compressor Operating Characteristics	14
Compressor Electrical Check	15
Adjusting the Temperature.....	15
Diagnostics / Service Mode	15
Description of Features.....	16
Alarms.....	16
Sabbath Mode.....	16
System Error Codes	17
Disassembly	17
User Interface Board (UI).....	17
Replacing the Main PCB.....	17
Evaporator Fan & Motor Assembly.....	17
Wiring Diagrams	18
D - Refrigeration System	20
Definitions	20
Recovery	20
Recycling.....	20
Reclaim	20
Safety Warnings.....	20
Compressor Testing	20
Charging Sealed Systems.....	20
Soldering	21
Basic Components.....	21
Refrigerant Cycle	21
Low/High Side Leak or Undercharge.....	21
Testing for Refrigerant Leaks	22
Compressor Replacement.....	22
To Flush the System.....	23
To Use Dry Nitrogen to Flush the System.....	23
To Use Refrigerant to Flush the System	23
Installing a New Compressor.....	23
Condenser Replacement.....	26
Filter-Drier Installation	26
Evaporator and Suction Line Replacement	26
Evacuating and Recharging	27
Equipment Needed for Evacuating & Recharging.....	27
Installing Evacuating & Recharging Equipment.....	27
Evacuating System.....	27
Charging the System.....	28
Preparing the Charging Cylinder.....	28
Final Leak Test.....	28
Evacuating and Recharging Connections.....	29
Verify Refrigerant Type in the System.....	30
Dedicated Equipment.....	30
R-134a Refrigeration Systems.....	30
Miscibility of R-134a and Ester Oil.....	30
Water in the Refrigeration System.....	31
Vacuum Pump Maintenance	31
Refrigerant Leaks.....	31
Leak Detection	33
R-134a Properties.....	33
HFC-134a, CFC-12 Pressure Temperature Chart	34
Inhalation Toxicity.....	35
Cardiac Sensitization.....	35
Spills or Leaks	35
Skin and Eye Contact	35
Combustibility of HFC-134a	36
Leak Testing	36
Bulk Delivery and Storage	36
Filling and Charging Operations.....	36
Refrigerant Recovery Systems	36
Thermal Decomposition.....	36
Exploded View Diagrams	37
System Diagram	37
Cabinet Diagram	38
Door Diagram	39
Addendum for Refrigerator Drawers	40
Disassembly-Evaporator Fan Motors	40
Disassembly-User Interface (UI).....	40
LED Lighting	41
Main PCB.....	41
Sealed System	41
Diagnostic / Service Mode	41
Diagnostic Tests.....	41
Wiring Diagrams.....	42

4 A - Installation

Important Safety Instructions

Safety Precautions

Do not attempt to install or operate your unit until you have read the safety precautions in this manual. Safety items throughout this manual are labeled with a Danger, Warning or Caution based on the risk type.

Definitions

 This is the safety alert symbol. It is used to alert you to potential personal injury hazards. Obey all safety messages that follow this symbol to avoid possible injury or death.

DANGER

DANGER indicates an imminently hazardous situation which, if not avoided, will result in death or serious injury.

WARNING

WARNING indicates a potentially hazardous situation which, if not avoided, could result in death or serious injury.

CAUTION

CAUTION indicates a potentially hazardous situation which, if not avoided, may result in minor or moderate injury.

IMPORTANT

Indicates installation, operation or maintenance information which is important but not hazard-related.

General Precautions

DANGER

RISK OF CHILD ENTRAPMENT. Before you throw away your old appliance, take off the doors and leave shelves in place so that children may not easily climb inside.

WARNING

- Never attempt to repair or perform maintenance on the unit until the electricity has been disconnected.
- Altering, cutting of power cord, removal of power cord, removal of power plug, or direct wiring can cause serious injury, fire and/or loss of property and/or life and will void the warranty.
- Do not lift unit by door handle.

CAUTION

- Use care when moving the unit. Some edges are sharp and may cause personal injury. Wear gloves when moving or repositioning the unit.
- Never install the unit behind closed doors. Be sure front grille is free of obstruction. Obstructing free air flow can cause the unit to malfunction, and may void the warranty.
- Allow unit temperature to stabilize for 24 hours before use.

CAUTION

- Use only genuine Electrolux replacement parts. Imitation parts can damage the unit and may void the warranty.

Installing the Wine Cooler / Beverage Center

Your Electrolux wine cooler / beverage center has been designed for either free-standing or built-in installation. When built-in, your wine cooler does not require additional air space for top, sides or rear. In either case, the front grille must **NOT** be obstructed.

NOTE

To ease unit installation and removal, it is recommended that the cabinet rough opening dimensions be increased by at least 1/4 inch over the dimensions given for your unit.

NOTE

All units require zero clearance when installed flush with a cabinet or wall. Electrolux stainless steel models require a minimum 2 7/8 inch handle clearance when installed against a wall or cabinet that extends beyond the front edge of the unit.

Unit Dimensions

Width	Height	Depth
23 ¹³ / ₁₆ inch	34-35 inches	26 ³ / ₄ inch

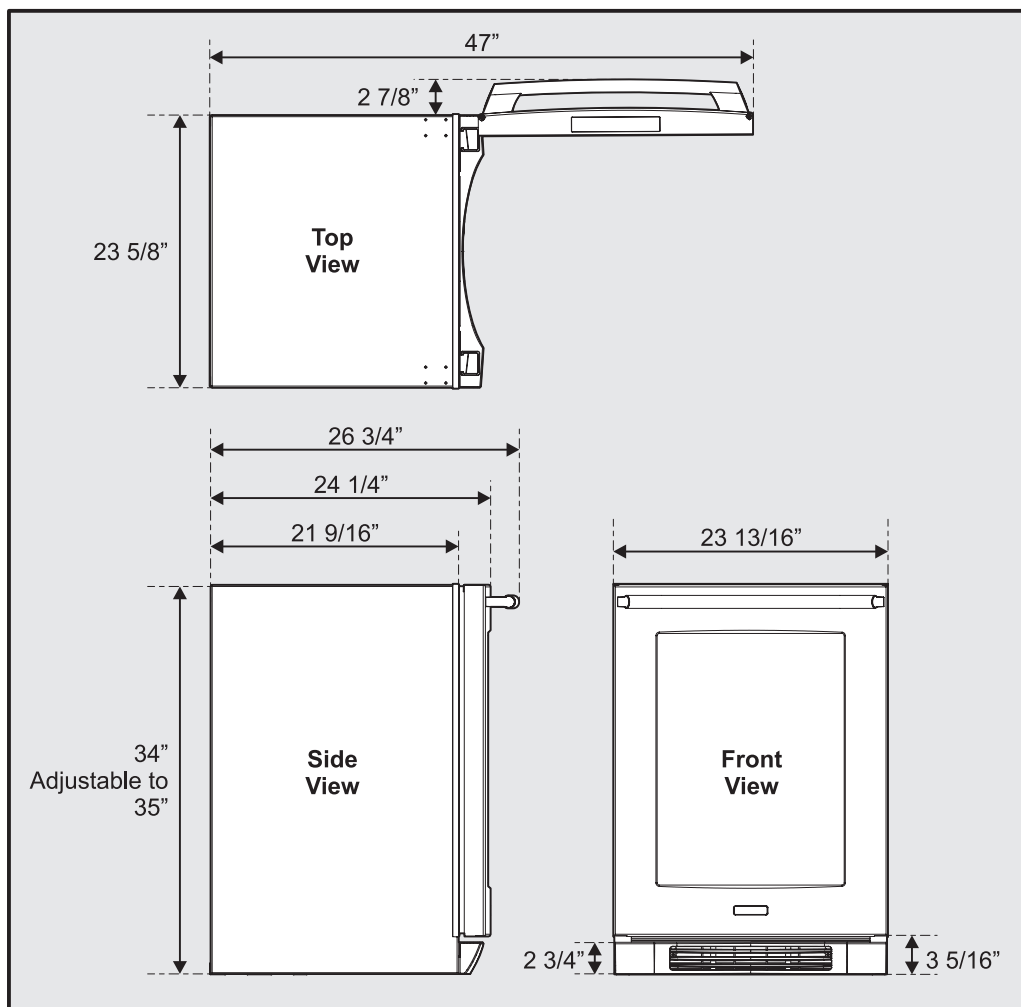

Product Dimensions

Site Preparation

- 1 Position the unit on a flat, level surface capable of supporting the entire weight of the unit. Remember the unit will be significantly heavier once it is fully loaded.
- 2 This unit requires a grounded and polarized 115 VAC, 60Hz, 15A circuit (normal household current).
- 3 Avoid connecting the unit to a Ground Fault Interruptor (GFI). GFIs are prone to nuisance tripping which will cause the unit to shut down. GFIs are generally not used on circuits which power equipment that must run unattended for long periods of time.
- 4 The unit must be installed according to your local codes and ordinances.
- 6 Wipe out inside of unit with a damp cloth.
- 7 Be sure to install the Anti-Tip bracket. Follow the instructions provided with the Anti-Tip bracket kit.



DANGER

ELECTROCUTION HAZARD!

Electrical Grounding Required. This appliance is equipped with a three prong (grounding) polarized plug for your protection against possible shock hazards.

- NEVER remove the round grounding prong from the plug.
- NEVER use a two-prong grounding adapter.
- NEVER use an extension cord to connect power to the unit.

Where a two-prong wall receptacle is encountered or a longer power cord is required, contact a qualified electrician to have it replaced in accordance with applicable electrical codes.

- 5 Position the unit to allow free air flow through the front grille.

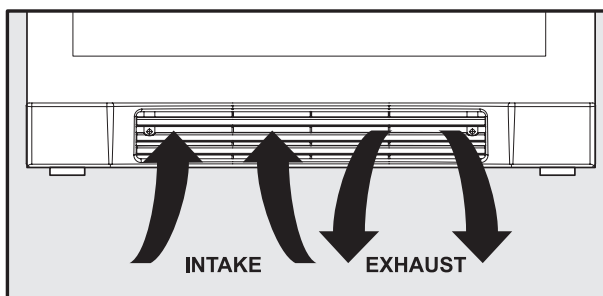

Reversing the Door

To reverse the door:

- 1 Disconnect power to the wine cooler / beverage center.
- 2 Remove toe grille by removing two (2) Philips screws. Remove plastic cap, reverse it and place it in the other side of the toe grille.

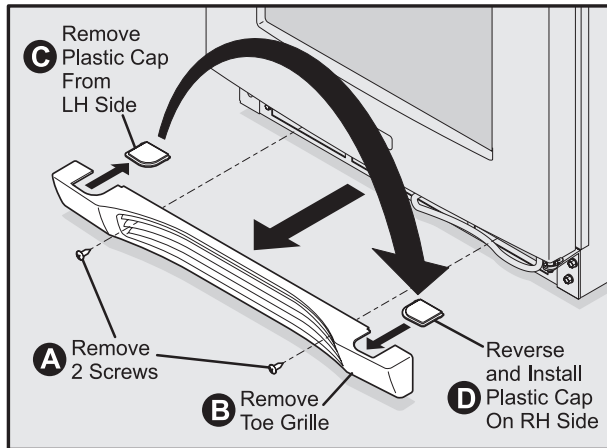

- 3 Disconnect door harness from connector bracket behind lower front panel. Pull harness from behind lower front panel so it is hanging below the door.

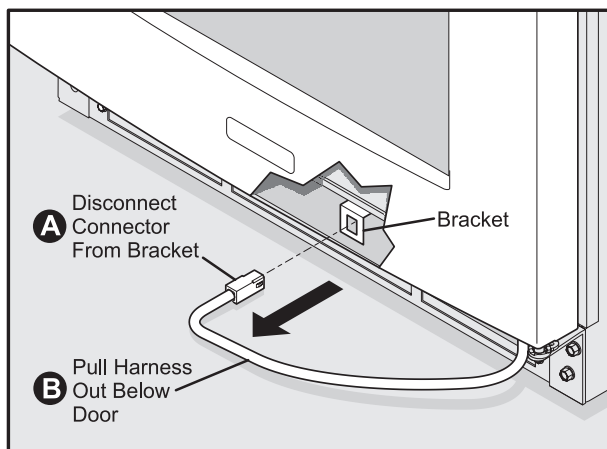

- 4 Remove upper right-hand (RH) hinge bracket by loosening four (4) Torx screws. Be careful to support the door while loosening and removing the upper hinge bracket.

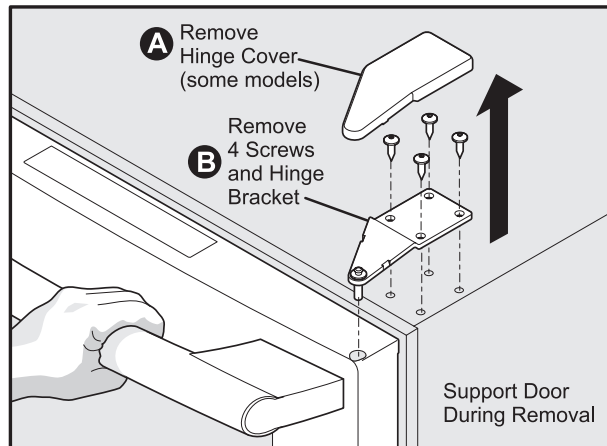

- 5 Lift the door off of the lower RH hinge bracket. Turn the door upside down and place on a soft, non-abrasive surface.

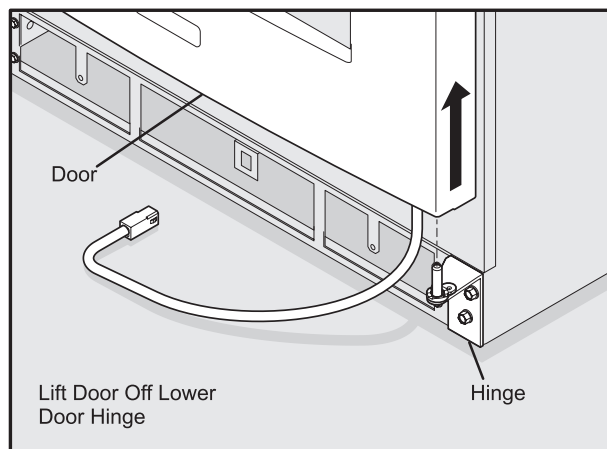

A - Installation

- 6 Remove access cover by removing two (2) Philips screws.
- 7 Shift door harness from one side to the other. Replace access cover.

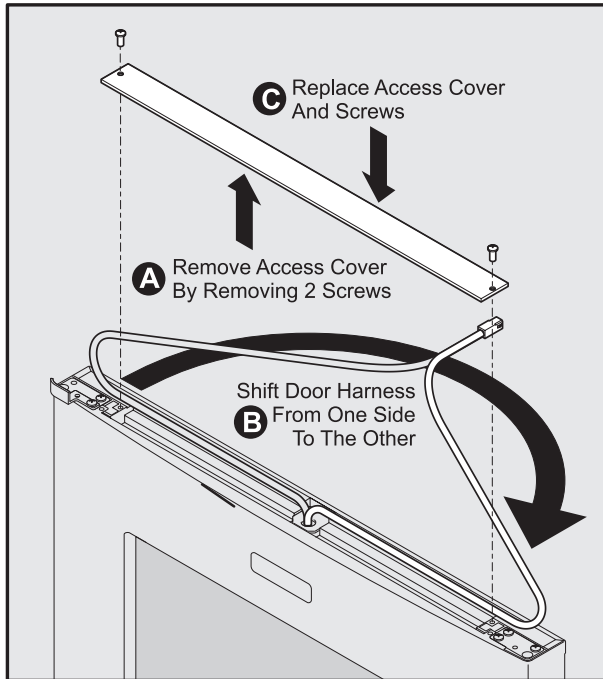

- 8 Remove plastic RH door closer by removing hex head screw. Remove metal RH door stop by removing hex head screw.

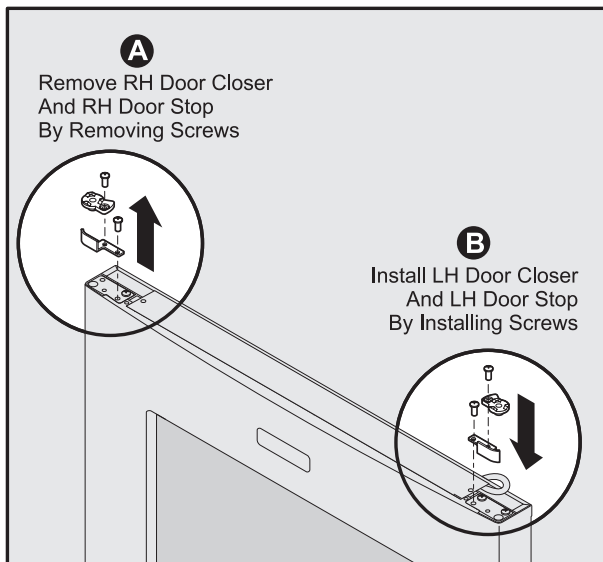

- 9 Install metal left-hand (LH) door stop by installing hex head screw.
- 10 Install plastic LH door stop by installing hex head screw.
- 11 Remove lower RH door hinge by removing two (2) hex head screws.

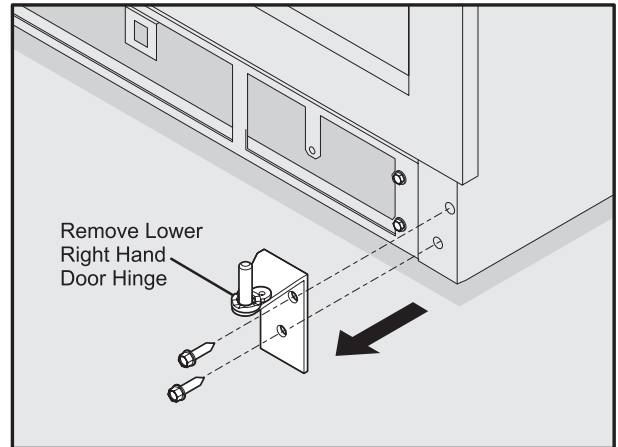

- 12 Install lower LH door closer in lower LH door hinge by installing hex head screw.
- 13 Install lower LH door hinge by installing two (2) hex head screws.

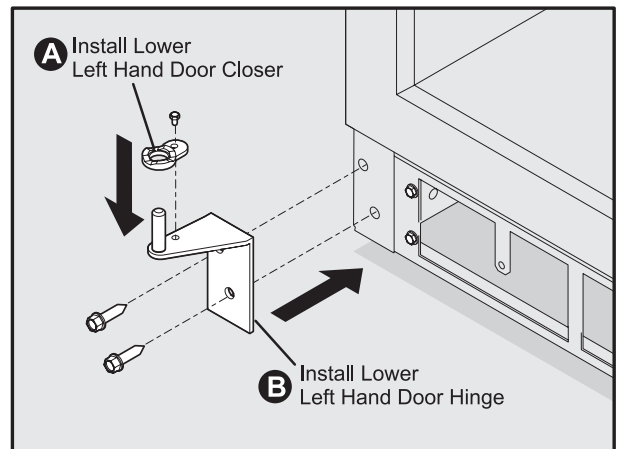

- 14** Remove button plugs from left side of cabinet and place in right side of cabinet. Remove button plug from upper left side of door and place in upper right side of door. Place door on lower LH hinge bracket.

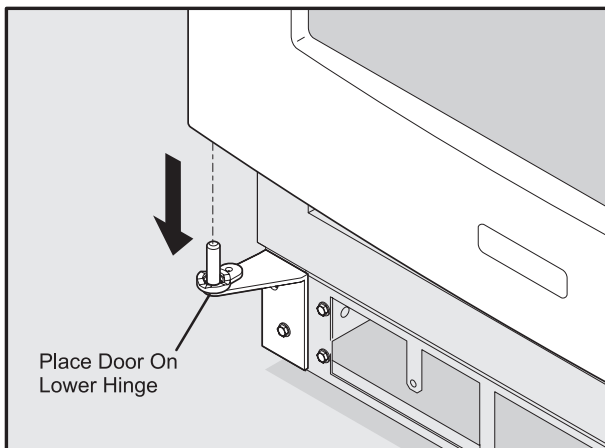
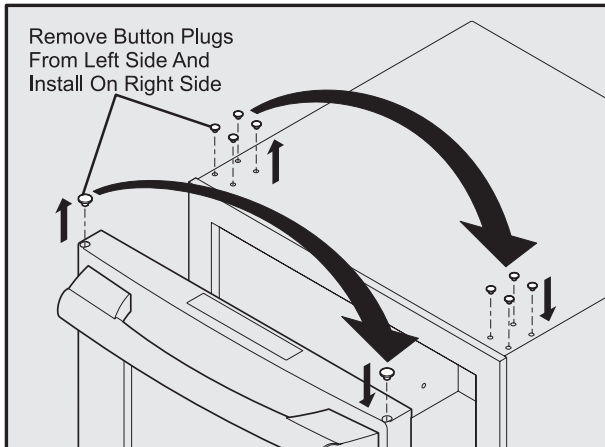

- 15** Install upper LH hinge bracket by installing four (4) Torx screws.

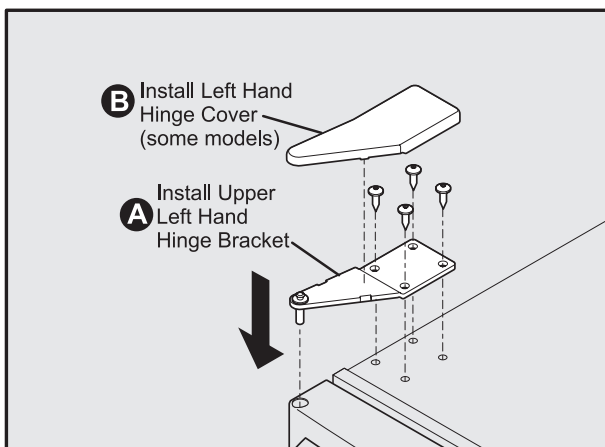

- 16** Route door harness behind lower front panel. Reconnect door harness to bracket.

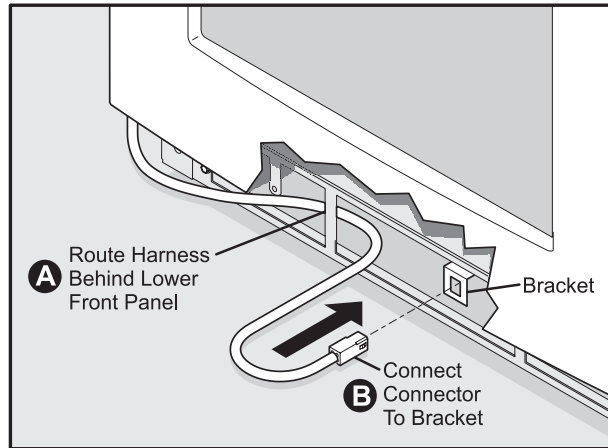

- 17** Reattach toe grille by installing two (2) Philips screws.

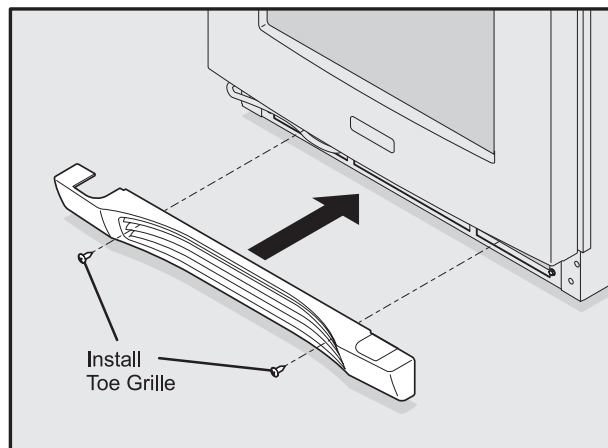

- 18** Reapply power.

Maintaining Your Wine Cooler/ Beverage Center

Periodic cleaning and proper maintenance will ensure efficiency, top performance, and long life. The maintenance intervals listed are based on normal conditions. You may want to shorten the intervals if you have pets or other special considerations.

Exterior Cleaning for Your Stainless Steel Model

- Your stainless steel model may discolor when exposed to chlorine gas, pool chemicals, salt water, or cleaners with bleach.
- Keep your stainless unit looking new by cleaning with a high quality, all-in-one stainless steel cleaner/polish on a monthly basis. Frequent cleaning will remove surface contamination that could lead to rust. Some installations will require cleaning on a weekly basis.
- DO NOT CLEAN WITH STEEL WOOL PADS.
- DO NOT USE CLEANERS THAT ARE NOT SPECIFICALLY INTENDED FOR STAINLESS STEEL (this includes glass, tile and counter cleansers).
- If any surface discolors or rusting appears, clean it quickly with Bon-Ami or Barkeepers Friend Cleanser and a non-abrasive cloth. Always clean in the direction of the grain. Always finish this process with a high quality, all-in-one stainless steel cleaner/polish to prevent further problems.
- USE OF ABRASIVE PADS SUCH AS SCOTCHBRITE WILL CAUSE THE GRAINING IN THE STAINLESS TO BECOME BLURRED.
- Rust that is allowed to linger can penetrate into the surface of the stainless steel and become impossible to remove.

CAUTION

- **Stainless steel models exposed to chlorine gas and moisture such as areas with spas or swimming pools, may have some discoloration of the stainless steel. Discoloration from chlorine gas is normal. Follow exterior cleaning instructions.**
- **NEVER USE CHLORIDE TO CLEAN STAINLESS STEEL.**

Interior Cleaning - as Required

- 1 Disconnect power to the wine cooler / beverage center.
- 2 Remove racks if desired, see “**WINE RACK REMOVAL/INSTALLATION**” below.
- 3 Wipe down the interior with a solution of non-abrasive mild detergent and warm water.
- 4 Rinse with clear water.
- 5 Reconnect power to the unit.

Wine Rack Removal/Installation

- 1 Open door fully.
- 2 Extend wine rack fully.
- 3 Ball bearing slide features plastic release latches on each side. Push release latches, then pull wine rack out.
- 4 To reinstall, push ball bearing slides in fully. Slide rack into ball bearing slide ensuring each side engages properly.

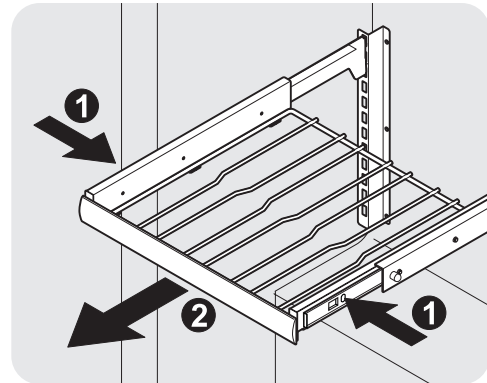

Glass Shelf Removal/Installation (Beverage Center Only)

- 1 Open door fully.
- 2 **Method 1 - removal of entire shelf assembly:**
 - a. Lift up on front edge and rear portion of shelf. Cantilever brackets will disengage from ladder.
 - b. To reinstall, slide shelf into cabinet ensuring the cantilever brackets engage fully in the proper holes. It may help to extend the glass portion.

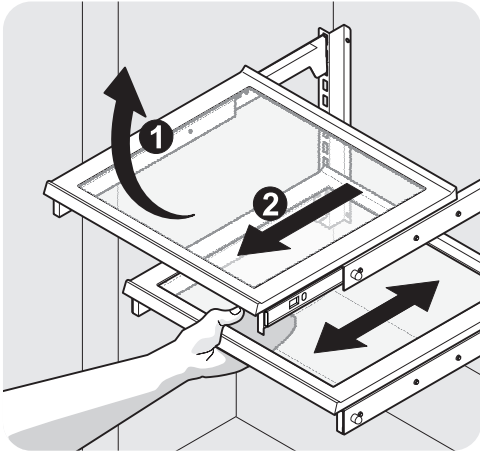

- 3 **Method 2 - glass shelf removal:**
 - a. Extend shelf fully.
 - b. Ball bearing slide features plastic release latches on each side. Push release latches then pull shelf out.
 - c. To reinstall, push ball bearing slides in fully. Slide shelf rack into ball bearing slide ensuring each side engages properly.

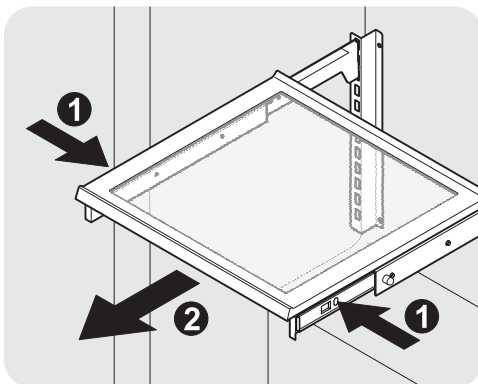

To Check/Replace Relay

1. Disconnect electrical supply to refrigerator.
2. Remove bale wire holding relay to compressor.
3. Remove relay assembly from compressor. (See Figure C2.)
4. Use small, flat-bladed screwdriver to disconnect leads to relay assembly.
5. Use flat headed screwdriver to gently pry capacitor from relay assembly.
6. Use ohmmeter to check resistance between terminals 5 and 6. Resistance should be 3 to 12 ohms at normal room temperature. Shorted relay will read 0 ohms. Open relay will read very high or infinite resistance.
7. If ohm readings are out of range, replace relay.
8. Reverse this procedure to re-assemble.

NOTE

When replacing leads to the PTC relay, ensure locking tabs snap into terminal.

Overload Protector

The overload protector is completely thermally operated. It will open from excessive heat or current. Unlike prior overloads, the internal bi-metal is not self-heating, and is not a part of the electrical circuit. The overload has a small built-in coil heater that is in series with the compressor start and run windings (See Figure C3).

To Check/Replace The Overload Protector

1. Disconnect electrical supply to refrigerator.
2. Remove bale wire holding relay to compressor.
3. Remove relay assembly from compressor.
4. Use flat headed screwdriver to gently pry capacitor from relay assembly.
5. Use small, flat-bladed screwdriver to disconnect leads to relay assembly. (Note: On some models you will have to remove bale wire and cover, to gain access to relay and overload protector.)
6. Use ohmmeter to check resistance between tab terminal and female pin terminal. Overload protector should have less than 1 ohm of resistance at normal room

temperature.

7. If ohm readings are out of range, install new Starter/Overload Assembly. See Figure 2.
8. Reverse this procedure to re-assemble.

NOTE

When replacing leads to the PTC relay, ensure locking tabs snap into terminal.

Run Capacitor

The run capacitor has permanently attached terminals which are connected to relay terminals 2 and 3.

NOTE

Some models are not equipped with a run capacitor.

To Check/Replace The Run Capacitor

1. Disconnect electrical supply to refrigerator.
2. Remove bale wire holding relay to compressor.
2. Use small, flat-bladed screwdriver to disconnect leads to relay assembly.
3. Use flat-bladed screwdriver to gently pry capacitor from relay assembly.
4. Discharge capacitor by shorting across terminals with 500K (1 watt) resistor for one minute.
5. Use ohmmeter set on the “**Ohms times 1000**” scale (if available), to check resistance across capacitor wire terminals.
 - The needle should jump towards zero ohms and quickly move back to infinity.
 - If the needle does not move, the capacitor is open.
 - If the needle reads a constant value at or near zero ohms, the capacitor is shorted out.
 - If the needle jumps toward zero and then moves back to constant high resistance (not infinity), the capacitor has a high resistance leak.
6. If ohm readings are out of range, replace capacitor.
7. Reverse procedures to re-assemble.

Compressor Start Circuit

When the compressor circuit is first energized, the solid state relay has low resistance (3-12 ohms), and both the run and start windings are energized to start the compressor. The run capacitor is being bypassed by the relay, and it has a minor function during compressor starting (See Figure C4).

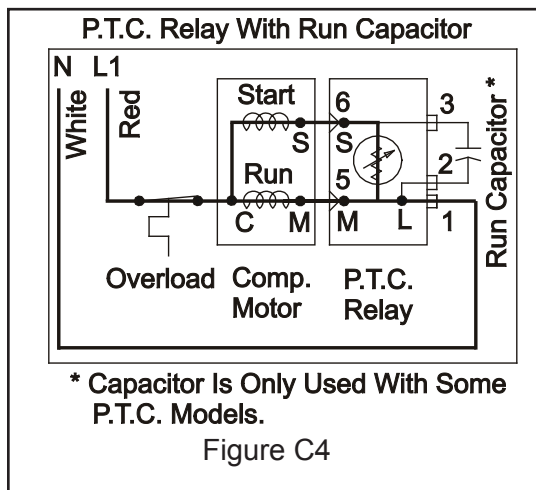

Figure C4

Compressor Run Circuit

When the self-heating solid state relay has reached sufficient temperature, it will abruptly change from low resistance (3-12 ohms) to very high resistance (10-20K ohms) and, in effect, switches off the start windings.

The relay no longer shunts the run capacitor. The run capacitor is now in series with the start windings. The only purpose of the run capacitor is to improve compressor operating efficiency, which it does by correcting the power factor of the compressor motor (See Figure C5).

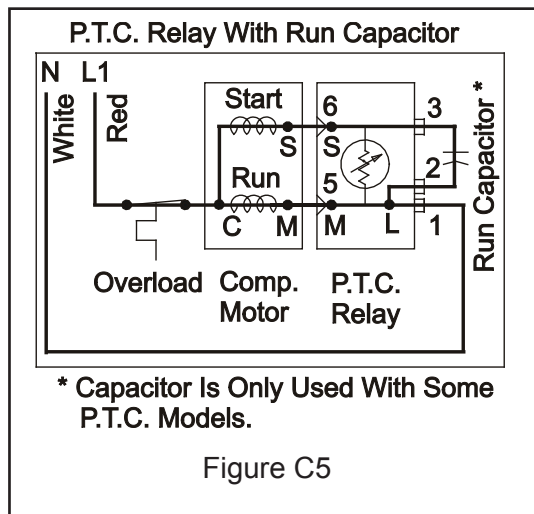

Figure C5

Compressor Operating Characteristics

- When the compressor electrical circuit is energized, the start winding current causes the relay to heat and switch off the start winding circuit.

NOTE

The relay will switch off the start winding circuit even though the compressor has not started (as when attempting to re-start after momentary power interruption).

- The overload protector is designed and calibrated to open the compressor electrical circuit with locked rotor run winding current on.
- With an open relay, the compressor will not start since there is little or no current to the start windings. The overload protector will open due to high locked rotor run winding current.
- With a shorted relay or capacitor, the compressor will start, and the overload protector will open.
- With an open or weak capacitor, the compressor will start and run. The compressor, however, will be operating at reduced efficiency of energy usage.
- If the compressor casing gets too hot, it will shut down on the overload. After the compressor has cooled down, the overload will reset and the compressor will restart.
- In rear mounted compressors, the overload will cycle the compressor on and off if the refrigerator is set in so tight that the air can't circulate around the condenser. In air cooled condensers, the overload will cut the unit off if the condenser becomes blocked or the fan motor stops running.

Compressor Electrical Check

If the compressor will not run, make a voltage check across the power lead terminals on the PTC Relay. (See Figure C5.)

The voltmeter should show line voltage if the thermostat knob is in normal operating position and not in the OFF position. If this check does not show a live circuit, the control thermostat and defrost timer wiring should be checked for loose and/or broken connections.

A control thermostat check can be made by using a piece of wire as a temporary bridge across two thermostat terminals. If the compressor starts and runs with the bridge, the control thermostat is at fault and should be replaced.

If the voltage check shows power supply at the PTC Relay terminals, use a test cord to check the compressor.

If the compressor does not start and run with the test cord, check the line voltage to see if there is more than 10% variation from the rated voltage. If voltage is correct and the compressor will not start and run, replace the compressor.

If the compressor starts and runs with the test cord, replace the PTC Relay.

Adjusting the temperature

Press the (+) or (-) indicator to adjust the temperature to the desired setting. The temperature display will begin to blink with the first touch. Adjust the temperature by touching the key. After (3) seconds of inactivity, the display will beep to accept the new temperature.



Diagnostics / Service Mode

To enter the service mode, press and hold the vacation mode key, while pressing the on/off key 3 times in 5 seconds. Temperature digit display will show (1). Each press of the left hand temperature UP (+) or left hand temperature DOWN (-) key will step through the Service Tests, (1) through (6). Press the "Mute Sounds" button to access the test selected. Once the test is accessed the display will show "o" and each press of the temperature UP (+) key will cycle forward through the test features (A-E) and display the Test information in the Display. Each press of the temperature DOWN (-) key will cycle back through the test features. Pressing the "Mute Sounds" key will exit from the test and display the current service test number.

TEST		
#1	Firmware Version	Displays firmware version of main PCB and user interface board.
#2	Evaporator Fan	Toggles the evaporator fan(s) on and off.
#3	Primary Sensor	Will Display: "P1" Normal, "P2" Open and "P3" Shorted.
#4	Evaporator Sensor	Will Display: "E1" Normal, "E2" Open and "E3" Shorted.
#5	Compressor	Toggles the compressor on and off.
#6	LED Display Test	Illuminates display LED's.
#7	Exit Service Mode	Hold left temperature (+) key for 5 seconds to exit service mode.

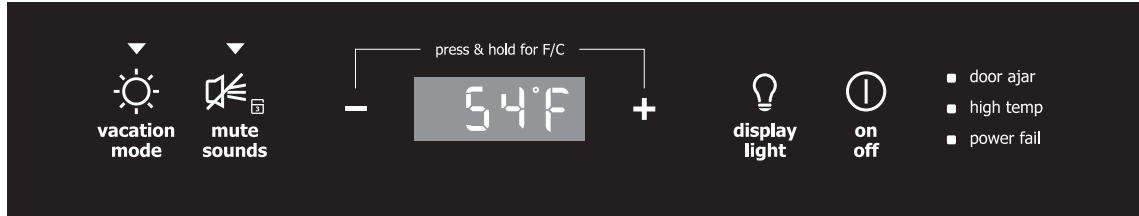

Description of Features

- vacation mode** Conserves energy by disabling interior lights and keypad inputs.
- mute sounds** Tones emitted by each keypress can be turned off based on user preference. The sounds are muted when the red indicator is lit. The **mute sounds** key also is used to acknowledge alarm conditions, denoted by a flashing red indicator. Press and hold the **mute sounds** key for three (3) seconds to enable **control lock**, which prevents undesired changes to the unit settings. Temperature display will show “LOC”.
- temperature mode** Simultaneously pressing the (+) and (-) keys causes the temperature display to toggle from Fahrenheit to Celsius and back again.
- display light** Manually activates the lights, regardless of whether the door is closed. Each successive keypress will advance the interior lights from “Off” to “Low Intensity” to “Maximum Intensity” then to “Off” again. Interior lighting is automatically disabled after 120 minutes, at which point the lights may be manually activated again if desired.
- on off** Press and hold for three (3) seconds. This allows the user to turn off the cooling system. The temperature display will display “OFF”. **THIS DOES NOT REMOVE POWER FROM THE UNIT.**

Sabbath Mode

Sabbath mode disables portions of the unit and its controls in accordance with the weekly Sabbath and religious holidays observed within the Orthodox Jewish community.



Sabbath mode is enabled and disabled by pressing and holding the **vacation mode** key for five (5) seconds. Temperature display shows “Sb” while in Sabbath mode.

The customer may open or close the door at any time without concern of directly turning on or off any lights, digital readouts, solenoids, fans, valves, compressor, icons, tones or alarms. After power failure, the unit will immediately return to Sabbath mode.

While in Sabbath mode, alarm indicators may illuminate, but will not be accompanied by audible alarms. The alarm indicators will continue to blink until the Sabbath mode is exited and the alarm condition is remedied.

For further assistance, guidelines for proper usage and a complete list of models with the Sabbath feature, please visit the web at <http://www.star-k.org>.

Alarms

- door ajar** If the door has been left open for five (5) minutes, an audible alarm will sound and the **door ajar** indicator will illuminate on the right side of the display. The **mute sounds** indicator will blink. Pressing the **mute sounds** key will acknowledge the alarm and disable the audible portion. The **door ajar** indicator will continue to blink until the door is closed.
- high temp (Beverage Center Only)** In the event of a high temperature condition, an audible alarm will sound, the temperature display will blink and display “HI” and the **high temp** indicator on the right side of the display will blink. The **mute sounds** indicator will blink. Pressing the **mute sounds** key will acknowledge the alarm and disable the audible portion. All other modes are turned off until the alarm is acknowledged. The **high temperature** indicator and “HI” will stay illuminated until a normal safe range operating temperature has been reached, at which time the temperature display will show the actual temperature.
- power fail** In the event of a power failure or initial power-up, an audible alarm will sound and the **power fail** indicator on the right side of the display will blink. The **mute sounds** indicator will blink. Pressing the **mute sounds** key will acknowledge the alarm and disable the audible portion. All other functions are disabled until the alarm is acknowledged, at which point the **power fail** indicator is turned off and the unit will resume normal operation. The **high temp** alarm (beverage center only) may also be illuminated until a safe temperature has been reached.

System Error Codes

Primary Sensor Open	Display will flash “P2” @ 1 hz.
Primary Sensor Shorted	Display will flash “P3” @ 1 hz.
Evaporator Mounted Sensor Open	Display will flash “E2” @ 1 hz.
Evaporator Mounted Sensor Shorted	Display will flash “E3” @ 1 hz.
Communication Error	Display will flash “CL” @ 1 hz.
Incorrect User Interface	Display will flash “UI” @ 1 hz.

Disassembly

User Interface board (UI)

To remove the User Interface board, it will be necessary to remove the door from it's hinge.

1. Disconnect power to unit.
2. Disconnect quick disconnecter to door UI located behind toe plate.
3. Pull out unit in order to gain access to the top hinge.
4. Loosen screws to hinge and lift up so door can be removed.
5. Remove screws located on underside of door that hold front panel.
6. Slide off front panel to gain access to UI.

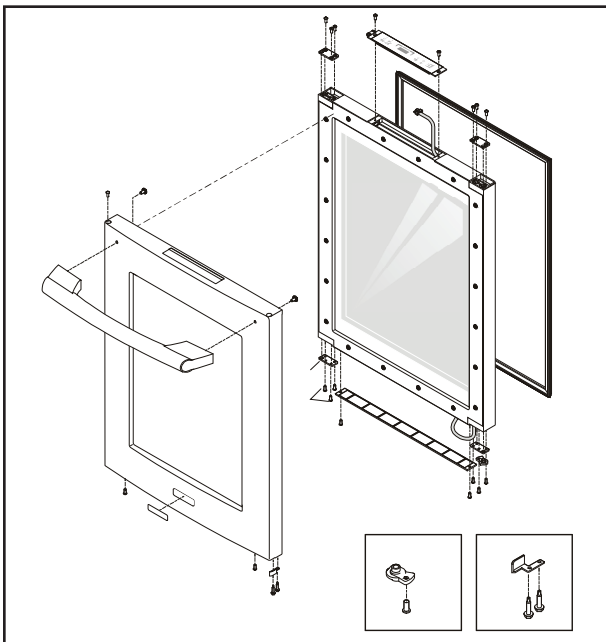

Replacing the main PCB

The main PCB is located under the unit behind the toe kick plate. It will be necessary to pull out the unit (if built in) and lean back to gain access.

The power supply for the interior lighting led's is located in front of the main PCB.

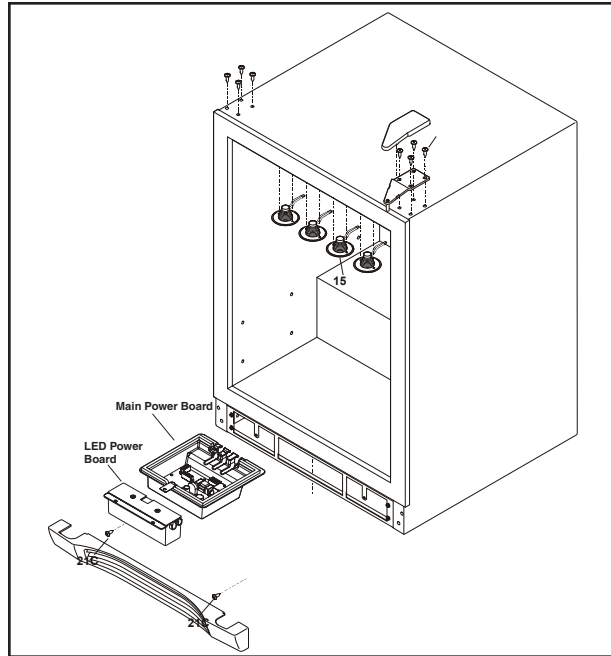

Evaporator Fan & Motor Assembly

The Beverage center uses one 12 vdc air circulation motor.

The Wine Cooler uses three 12 vdc air circulation motors.

To Remove Evaporator Fan Motor

1. Disconnect wine cooler or Beverage Center from electrical supply.
2. Remove shelving from interior.
3. Remove the four screws that hold on the evaporator cover.
4. Remove Evaporator cover, disassemble fan motor, and replace.



Beverage Center
Evaporator fan (1)



Wine Cooler
Evaporator Fans (3)

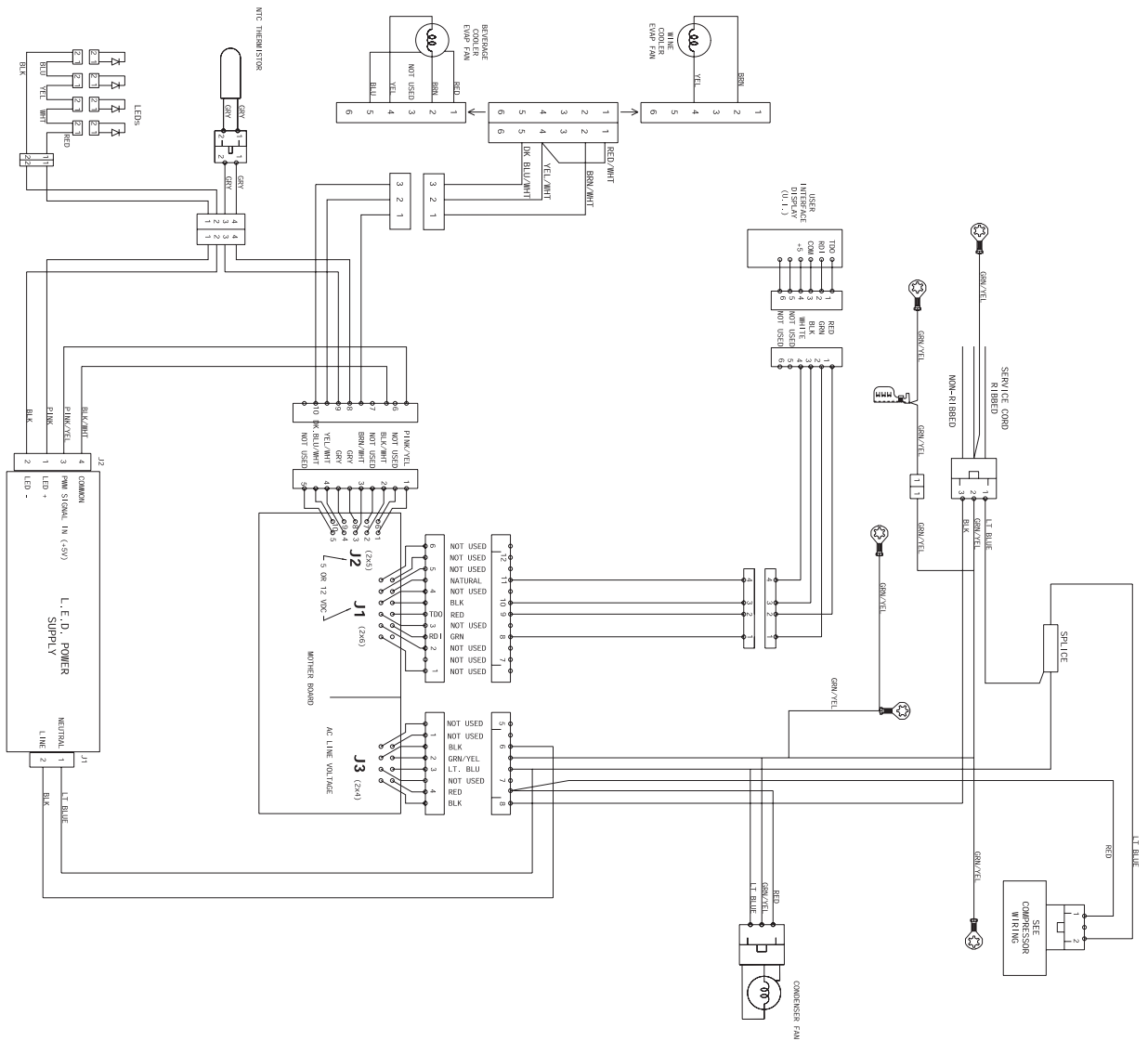

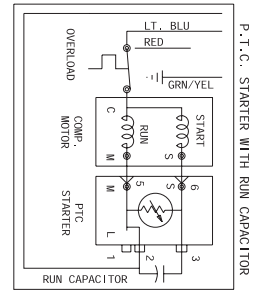

*CAPACITOR IS ONLY USED WITH SOME P.T.C. MODELS
STANDARD AC COMPRESSOR

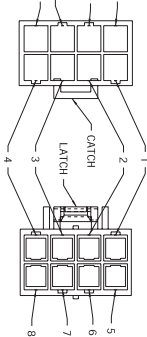
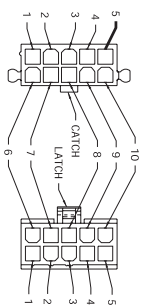
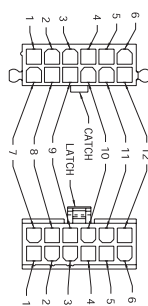
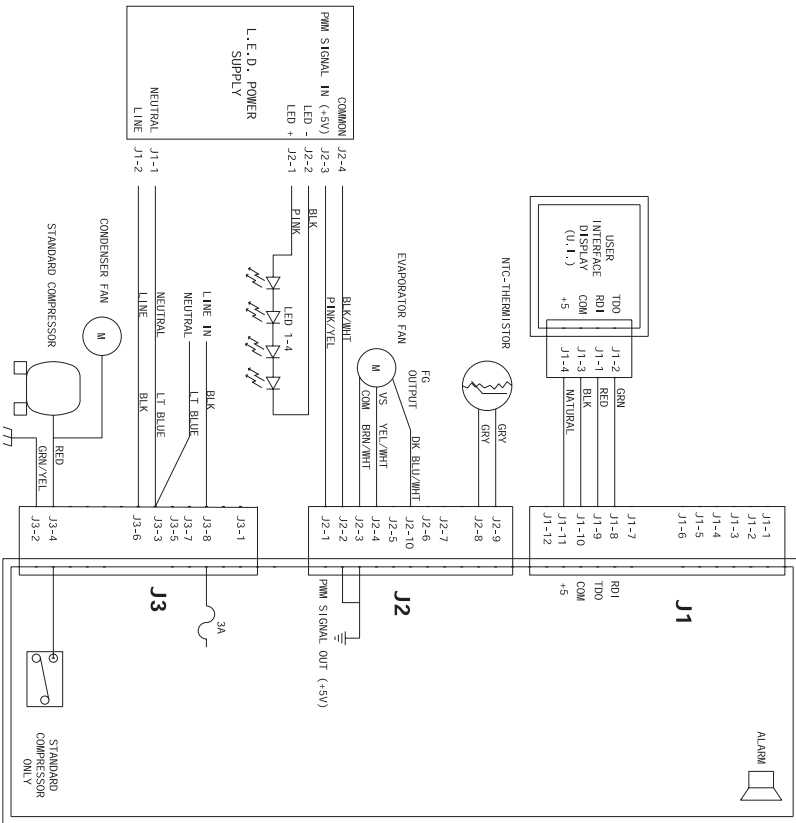

**NOTICE**

Instructions given here are furnished as a guide. Persons attempting to use these instructions to make repairs to the sealed refrigeration system should have a working knowledge of refrigeration and previous training on sealed system repair, and an EPA certification for servicing refrigeration systems.

**IMPORTANT NOTICE**

Effective July 1, 1992, the United States clean air act governs the disposal of refrigerants such as R-134a. Therefore, when discharging or purging the sealed system use an epa approved refrigerant recovery system as outlined in the final rule on the protection of stratospheric ozone and refrigerant recycling, which was published in the Federal Register May 14, 1993.

**NOTE**

Frigidaire does not permit the use of recovered refrigerant in the servicing of our products for in-warranty and out-of-warranty repairs or for products covered by service contracts. Therefore, only new refrigerant or refrigerant that has been reclaimed back to new specifications by a refrigerant manufacturer is to be used.

Definitions**Recovery:**

To remove refrigerant in any condition from a system and store it in an external container without necessarily testing or processing it in any way.

Recycling:

To clean refrigerant for reuse by oil separation and single or multiple passes through devices, such as replaceable core filter-driers, which reduce moisture, acidity and particulate matter. This term usually applies to procedures implemented at the field job site or at a local service shop.

Reclaim:

To reprocess refrigerant to new product specifications by means which may include distillation. Will require chemical analysis of the refrigerant to determine that appropriate product specifications are met. This term usually implies the use of processes or procedures available only at a reprocessing or manufacturing facility.

Safety Warnings**Compressor Testing**

Whenever testing a compressor, extreme caution should be used to prevent damaging the terminals. A compressor with a damaged terminal or a grounded winding can expel a terminal from its insulated housing when the compressor is energized. If this happens, a mixture of refrigerant and oil will be released that could be ignited by an external heat source (open flame, heater, etc.). Also, if there is air in the system when this happens, a spark at the compressor shell could ignite the refrigerant and oil mixture.

Charging Sealed Systems

Overcharging a refrigeration system with refrigerant can be dangerous. If the overcharge is sufficient to immerse the major parts of the motor and compressor in liquid refrigerant, a situation has been created which, when followed by a sequence of circumstances can lead to the compressor shell seam separating.

A hydraulic block occurs, preventing the compressor from starting. This condition is known as locked rotor. Electric current continues to flow through the compressor motor windings which become, in effect, electric resistance heaters. The heat produced begins to vaporize the excess refrigerant liquid causing a rapid increase in system pressure. If the compressor protective devices fail, the pressure within the system may rise to extremes far in excess of the design limits. Under these conditions, the weld seam around the compressor shell can separate with explosive force, spewing oil and refrigerant vapor which could ignite.

To eliminate this exceedingly rare but potential hazard, never add refrigerant to a sealed system. If refrigerant is required, evacuate the existing charge and recharge with the correct measured amount of the refrigerant specified for the system.

Soldering

WARNING

Wear approved safety glasses when working with or on any pressurized system or equipment. Have an approved dry type fire extinguisher handy when using any type of gas operated torch.

1. All joints to be soldered must have proper fit. Clearance between tubes to be soldered should be from .001" to .006". It is not practical to actually measure this; however, you do not want a dry fit or loose fit. Tubing joints should overlap about the distance of their diameter except for restrictor tubes, which should be inserted 1.25".
2. Clean all joint areas with fine steel wool or preferably an abrasive cloth, such as grit cloth No. 23 or Scotch-Brite.
3. Apply a thin film of liquid flux recommended for silver soldering to surfaces to be joined and to surfaces immediately adjacent to joint.
4. Align tubing so no stress is on joint. Do not move tubing while solder is solidifying or leaks will result.

CAUTION

During application of heat, use wet cloths to prevent heat from conducting to areas other than the soldered joint. Use a sheet of metal or torch guard pad as a heat deflector to keep flame away from inflammable materials and painted surfaces.

5. Use a torch of adequate capacity so joint can be quickly heated with a minimum of heat travel to other points. Use a good grade of silver solder.
6. Solder connections. If tubing is properly cleaned and fluxed, solder will flow readily. Use only enough solder to make a good bond.
7. Allow joint to cool, then wash exterior with water to remove flux.

Basic Components

The basic components of a refrigerator are a compressor, condenser, evaporator, heat exchanger (capillary tube and suction line), drier and perimeter hot tube.

Refrigerant Cycle

The refrigerant cycle is a continuous cycle that occurs whenever the compressor is in operation. Liquid refrigerant is evaporated in the evaporator by the heat that enters the cabinet through the insulated walls and by the heat from product load and door openings. The refrigerant vapor is then drawn from the evaporator, through the suction line to the compressor. Compression raises the pressure and temperature of the vapor in the compressor and the vapor is then forced through the discharge valve into the discharge line and into the condenser. Air passing over the condenser surface removes heat from the high pressure vapor which then condenses to a liquid. The liquid refrigerant then flows from the condenser to the evaporator through the small diameter liquid line (capillary tube). Before it enters the evaporator, the liquid refrigerant is sub-cooled in the heat exchanger by the low temperature suction vapor in the suction line.

Low/High Side Leak or Undercharge

A loss of refrigerant can result in any of the following:

1. Excessive or continuous compressor operation.
2. Above normal freezer compartment temperature.
3. A partially frosted evaporator (depending on amount of refrigerant loss).
4. Below normal freezer compartment temperature.
5. Low suction pressure (vacuum).
6. Low wattage.

The condenser will be "warm to cool", depending on the amount of refrigerant lost.

When refrigerant is added, the frost pattern will improve, the suction and discharge pressures will rise, the condenser will become hot and the wattage will increase.

In the case of a low side refrigerant leak resulting in complete loss of refrigerant, the compressor will run but will not refrigerate. Suction pressure will drop below atmospheric pressure and air and moisture will be drawn into the system saturating the filter drier.

If there is reason to believe the system has operated for a considerable length of time with no refrigerant and the leak occurred in the low side of the system, excessive amounts of moisture may have entered the system. In such cases the two stage service Dryer Filter part number 5303918288 and vacuum procedure listed under Refrigerant Leaks need to be followed to prevent repetitive service.

If a slight undercharge of refrigerant is indicated and no leak can be found after a thorough leak test, the charge can be corrected without changing the compressor.

If a high side leak is located and some refrigerant remains in the system it is not necessary to change the compressor.

Testing for Refrigerant Leaks

If the system is diagnosed as short of refrigerant and the system has not been recently opened, there is probably a leak in the system. Adding refrigerant without first locating and repairing the leak or replacing the component will not permanently correct the difficulty. The leak must be found. Sufficient refrigerant may have escaped to make it impossible to leak test effectively. In such cases, add a ¼" line piercing valve to the compressor process tube. Add sufficient refrigerant vapor to increase the pressure to 40 to 50 lb. per sq. in. Check the low side for leaks. Run the compressor 2 or 3 minutes and check the high side for leaks. Recover refrigerant using an EPA approved recovery system.



NOTE

The line piercing valve (clamp-on type) should be used for test purposes only. It must be removed from system after it has served its purpose.

Compressor Replacement



CAUTION

NEVER install a new compressor without first checking for possible system contamination.

To check for contamination, obtain oil sample from old compressor.

- If the oil has burned odor, but no color change or residue — follow instructions in section “Installing A New Compressor”.

- If oil has a burned odor and a sugar or gritty feel as well as showing signs of contamination (dark color) — follow instructions in next section, *To Flush The System*. Remove as much of contamination as possible from system before installing new compressor and filter-drier.

To Flush The System



NOTE

It is recommended that system be flushed with dry Nitrogen. However, if refrigerant is used to flush the system you must look at the serial plate to see what type of refrigerant is used in the system. This is the only refrigerant that can be used to flush the system and it must be recovered.



CAUTION

Use extreme care when using Dry Nitrogen to flush systems. Pressure in nitrogen cylinder could be as high as 2000 psi. Nitrogen cylinder must be equipped with approved pressure regulator and pressure relief valve. Ensure that your hoses have adequate ratings for pressure involved and that all of your equipment is in good condition.

The end of the flushing hose on this tank regulator must be equipped with a hand shut-off valve (Robinair No. 40380). Close hand shut-off valve and adjust nitrogen regulator to correct pressure before proceeding with flushing procedure.

To Use Dry Nitrogen To Flush The System:

1. Remove compressor and filter-drier. Connect process coupling to outlet tube of condenser.
2. Fasten cloth over other end of coil to prevent old oil from spraying over room.
3. Connect hand shut-off valve on flushing hose to process coupling.
4. Slowly open hand shut-off valve and allow nitrogen to flow through condenser until discharge is clear.



CAUTION

DO NOT exceed 300 PSIG.

5. Disconnect cap tube from evaporator. Flush evaporator in same manner as condenser.

CAUTION

DO NOT exceed 150 PSIG.

6. Flush cap tube. This is only possible if you have proper service valve adaptor.

CAUTION

DO NOT exceed 300 PSIG.

7. Reassemble system.

To Use Refrigerant To Flush The System:

CAUTION

Refrigerant used for flushing must be recovered into a recovery system. Meter amount of refrigerant used for flushing with your charging cylinder. DO NOT OVERFILL THE BAG.

1. Disconnect the suction and discharge lines from the compressor and remove the filter-drier. Connect process coupling to outlet and inlet tube of condenser.
2. Connect hose to outlet process coupling and charging cylinder. Connect another hose to inlet coupling and recovery system.
3. Open charging cylinder and allow refrigerant to flow through condenser until discharge into bag is clear.

NOTE

To flush evaporator and heat exchanger you must remove evaporator from inside product to disconnect cap tube.

4. Disconnect capillary tube from evaporator. Flush evaporator in same manner as condenser.
5. Flush cap tube. This is only possible if you have proper service valve adaptor.
6. Reassemble system.

Installing a New Compressor

NOTE

Entirely new compressors have been developed for use with R-134a and Ester oil refrigeration systems. Both compressor and electric motor have been modified. Old compressors intended for R-12 refrigerant must not be used for new systems charged with R-134a.

Replacement of compressor and installation of filter-drier must be done in a continuous sequence so system is exposed to atmosphere no longer than necessary.

All replacement compressors are shipped with rubber plugs in the suction, discharge and process tubes and contain the correct oil charge and a holding charge of inert gas. Compressors have a low-side process tube attached to the compressor shell. A high-side process tube is attached to the filter-drier.

WARNING

Do not operate reciprocating compressor when charging liquid refrigerant into system through its process tube.

Replacement compressors for refrigerator may have an oil cooler even if the original compressor did not. If the product is not equipped for an oil cooler, leave the plastic caps in place and install the compressor connecting only to the suction and discharge lines of the new compressor.

Before installing the replacement compressor remove the discharge plug and check for the pop sound of the inert gas leaving the compressor.

CAUTION

DO NOT use compressor if you do not hear this sound.

If the compressor checks OK, reinstall the plug. Do not remove any of the plugs again until the compressor is in position and you are ready to braze the lines.

CAUTION

On R-134a systems, compressor must NOT be left open to atmosphere for more than 10 minutes to prevent moisture contamination of oil.

A new compressor which is cold (e.g. after having been kept in a cold service van) should be left to warm to the surrounding temperature before the plugs on the compressor connections are removed. This will help prevent condensation from forming in the oil and the compressor. Also, avoid opening the system when any of the components or lines are cold.



NOTE

Release holding charge (release slowly to avoid oil discharge) on new compressor to ensure there is no leak in seam or tubing. Reinstall rubber plug.

1. Disconnect electrical supply to refrigerator.
2. Remove compressor access panel.
3. Remove rail and condenser fan schroud screws.
4. Remove fan motor harness clamp located below heat exchanger wiring harness cover
5. Disconnect condenser fan motor multiconnector.
6. Pull compressor assembly straight out. See Figure E1.
7. Recover refrigerant by using EPA approved recovery system.
8. Remove leads from compressor motor terminals.
9. Remove mounting clips and washers.
10. After refrigerant is completely recovered, cut suction and discharge lines as close to compressor as possible. Leave only enough tubing to pinch off and seal defective compressor. Plug or tape any open system tubing to avoid entrance of moisture and air into system. Remove inoperable compressor and transfer mounting parts to new compressor.
11. Install new compressor in exact same manner as original compressor.
12. Reform both suction and discharge lines to align with new compressor. If they are too short, use additional lengths of tubing. Joints should overlap 0.5" to provide sufficient area for good solder joint. Clean and mark area where tubing should be cut. Cut tubing with tubing cutter. Work as quickly as possible to avoid letting moisture and air into system.



NOTE

If low-side process tube is too short, silver solder four inch piece of tubing onto process tube at this time.

13. Solder all connections according to soldering procedure.
14. Remove original filter-drier.



CAUTION

DO NOT unbrazed old filter-drier from system. This will vaporize and drive moisture from desiccant back into system. The old filter-drier should be cut out of system.

15. Install new filter-drier at condenser outlet.
16. Evacuate and charge system using recommended procedure described under Evacuating and Recharging.
17. Reconnect compressor terminal leads in accordance with refrigerator wiring diagram.
18. Reassemble unit.

Figure E1

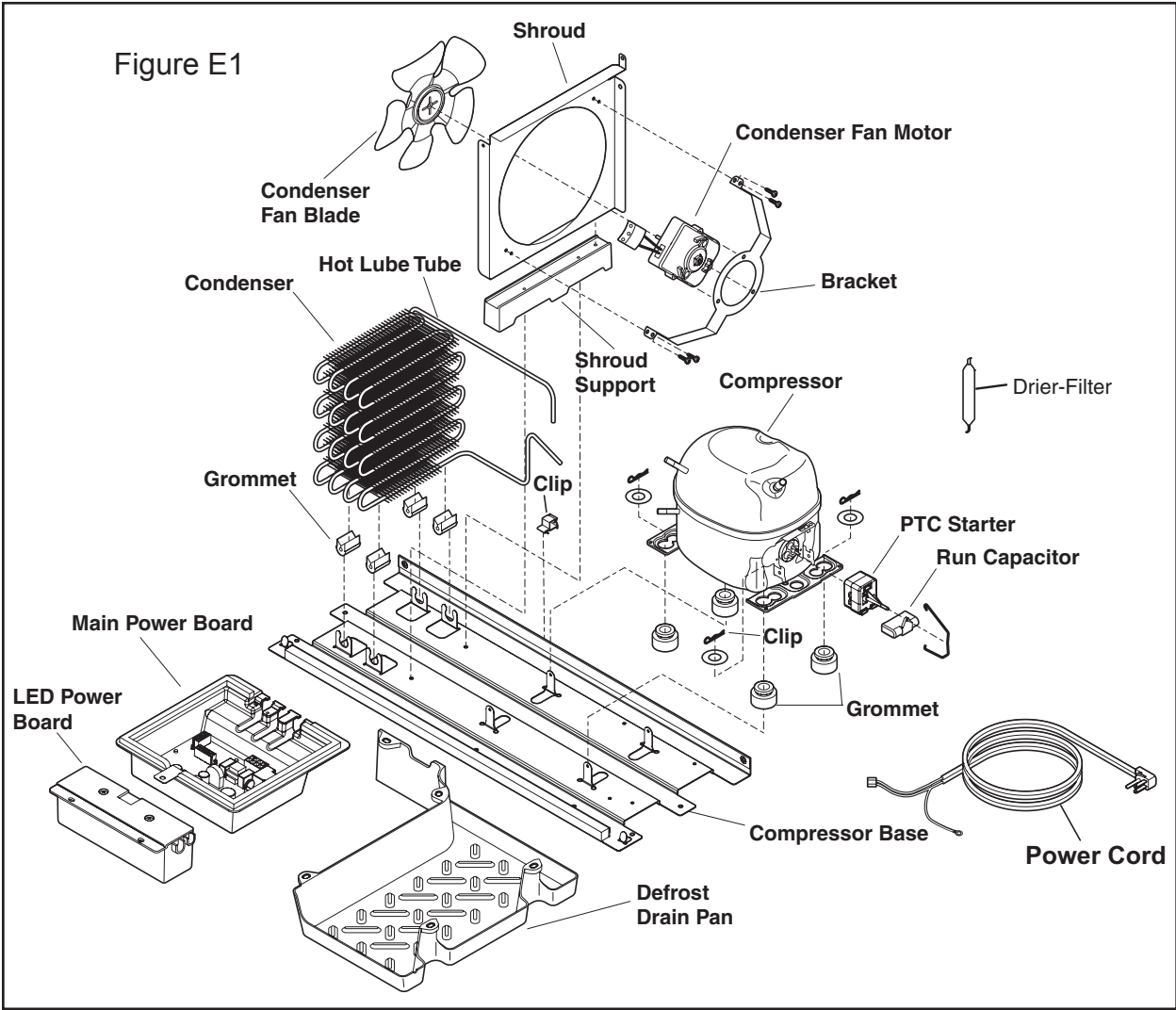

Condenser Replacement

1. Disconnect electrical supply to refrigerator.
2. Remove compressor access panel.
3. Recover refrigerant by using EPA approved recovery system.
4. Remove condenser fan mounting screws.
5. Unplug fan motor harness located in back of fan motor.
6. Remove fan motor and fan blade.
7. After refrigerant is completely recovered, disconnect inlet and discharge lines from condenser.
8. Remove white condenser retainer clip from fan bracket and condenser.
9. Lift front of condenser and the two rubber gromets out of retainer in base plate.
10. Remove old condenser out the back of cabinet.
11. Install replacement condenser.
12. Remove original filter-drier.

CAUTION

DO NOT unbrazed the old filter-drier from the system. This will vaporize and drive moisture from the desiccant back into the system. The old filter-drier should be cut out of the system.

13. Install new filter-drier at condenser outlet.
14. Evacuate and charge the system using recommended procedure described under Evacuating and Recharging.
15. Reassemble unit.

Filter-Drier Installation

Any time the sealed system is opened and the refrigerant charge is removed, the liquid line filter-drier must be replaced and the system thoroughly evacuated before recharging.

CAUTION

DO NOT unbrazed the old filter-drier from the system. This will vaporize and drive moisture from the desiccant back into the system. The old filter-drier should be cut out of the system.

CAUTION

Use only a 15 gram XH9 liquid line filter-drier (part number 5303305677) when servicing refrigerator and freezer systems. This filter-drier is compatible with either R-12 or R-134a refrigerant.

1. Disconnect unit from source of power.
2. Recover refrigerant by using an EPA approved recovery system.
3. Using a 3 cornered file, score a groove around capillary tube as close to old filter-drier as possible. Break capillary tube along score mark from filter-drier.
4. Cut condenser outlet tube at filter-drier. Discard filter-drier.
5. Thoroughly clean condenser outlet tube and capillary tube.
6. Place inlet connection of filter-drier over condenser tube approximately 1/4" and solder.
7. Insert capillary tube input end into filter-drier outlet. Do not allow tube to bottom against screen. Solder carefully so that solder does not plug capillary tube.
8. Install process tube adaptor to filter-drier.
9. Evacuate and charge system using the recommended procedure described under Evacuating and Recharging.
10. Reassemble unit.

Evaporator and Suction line Replacement

1. Disconnect electrical supply to refrigerator.
2. Recover refrigerant by using EPA approved recovery system.
3. Remove shelving.
4. Remove four screws that hold cover plate to evaporator.
5. Remove four screws that hold evaporator.
6. Cut or remove suction line from compressor.
7. Cut filter-drier from condensing unit.
8. Remove sealant from cabinet where suction line enters.
9. Remove evaporator and suction line as one piece.

10. Install new evaporator with attached suction line.
11. Seal cabinet.
12. Install new filter drier at condenser outlet.
13. Evacuate and charge the system using recommended procedure described under Evacuating and Recharging.

Evacuating and Recharging



CAUTION

Check the serial plate for the correct refrigerant type. It is extremely important to verify the type of refrigerant in the system before starting any sealed system repairs.

With the possible exception of the vacuum pump, all service equipment that comes in contact with R-134a during evacuation and recharging must be dedicated. Accordingly, R-134a will require a dedicated charging cylinder, manifold gauge set, process tube adaptors, and hoses. Any residual mineral oil on other tools (tubing cutter, etc.) must be thoroughly cleaned off before using on R-134a/Ester oil systems. It will be necessary to check with the manufacturer of your vacuum pump for refrigerant and oil compatibility issues.

If you use a vacuum pump with mineral oil to evacuate an R-134a system, it is **ABSOLUTELY ESSENTIAL** to have a shut-off valve between the pump and your manifold gauge set as shown on page Figure E2. The hand valve must be closed during all times when the vacuum pump is not operating. This will prevent the migration of mineral oil vapor into the R134a/Ester oil system. If the vacuum pump should stop during evacuation for any reason, the hand pump shut-off valve must be closed immediately.

Insure that your refrigeration hoses are specified for use with R-134a refrigerant. Research has shown that compounds in standard refrigeration hoses may enter sealed systems and ultimately restrict the cap tube in an R-134a system.

Equipment Needed for Evacuation & Recharging:

- Heated charging cylinder
- Standard 3-port manifold gauge set:
 - 4 charging hoses
 - Tee fitting with valve core stem removed (Robinair No. 40396)
 - Hand shut-off valve (Robinair No.40380)
- Two stage vacuum pump
- Process tube adapter kit (Robinair No. 12458)
- Tubing cutter
- Pinch-off tool capable of making leak proof seal
- Complete brazing torch set
- Small 3-corner file
- Grit cloth or Scotch-Brite
- 45% silver solder and flux
- Heat Gun

Installing Evacuation and Recharging Equipment

1. Disconnect refrigerator from electrical supply.
2. If compressor was replaced, install correct sized process tube adaptor on process tube. If compressor was not replaced, cut process tube with tubing cutter leaving as much tube as possible and install correct size process tube adaptor.
3. Install correct sized process tube adaptor on high-side process tube.
4. Attach refrigeration service gauge manifold to system in following order:
 - Low-side (compound gauge) hose to suction side process tube adaptor.
 - High-side (pressure gauge) hose to high-side process tube adaptor.
 - Center port manifold hose before hand shut-off valve to charging cylinder.
 - Center port manifold hose after hand shut-off valve to vacuum pump.

**WARNING**

R-134a systems are particularly susceptible to moisture contamination which can only be prevented by evacuating the system for a minimum of 30 minutes to attain a minimum 29.9 inch (500 micron or lower) vacuum.

Evacuating System

To achieve the required levels of evacuation, a properly maintained two stage vacuum pump in good condition is required. It is absolutely essential to maintain your vacuum pump according to the manufacturer's instructions including required oil changes at the recommended intervals. Vacuum pump oil should always be changed after evacuating a contaminated system.

Vacuum pump performance should be checked periodically with a micron gauge.

1. Make certain that charging cylinder valve, hand shut-off valve, and manifold gauge valves are closed.
2. Start vacuum pump.
3. Open hand shut-off valve and slowly open both manifold valves, turning counterclockwise, for two full rotations.

**CAUTION**

If high vacuum equipment is used, just crack both manifold valves for a few minutes and then open slowly for the two full turns counterclockwise. This will prevent the compressor oil from foaming and being drawn into the vacuum pump.

4. Operate the vacuum pump for a minimum of 30 minutes to a minimum of 29.9" (500 micron) vacuum.
5. Close hand shut-off valve to vacuum pump. Watch compound gauge for several minutes. If reading rises, there is a leak in the system, go to step 6. If no leak is indicated, stop vacuum pump. System is now ready for charging.
6. If a leak is indicated, stop vacuum pump and introduce a small charge of refrigerant into system by cracking valve on bottom of charging cylinder until system is pressurized to 40 or 50 lbs psig.

7. Leak test low-side. Close compound gauge. Run compressor for a few minutes and leak test high-side. When leak is found, recapture refrigerant using EPA approved recovery system Repair and go back to step 1.

Charging The System**CAUTION**

Check the serial plate for the correct refrigerant type. It is extremely important to verify the type of refrigerant in the system before starting any sealed system repairs.

After charging the system with liquid be certain to wait at least 5 minutes before starting the compressor to give the refrigerant a chance to disperse throughout the system. Otherwise the compressor could be damaged by attempting to pump excessive quantities of liquid.

Preparing The Charging Cylinder:

1. Make certain that hand shut-off valve to vacuum pump is closed.
2. Close high-side manifold gauge valve.
3. Set charging cylinder scale to pressure indicated on cylinder pressure gauge.
4. Observe refrigerant level in sight glass. Subtract amount to be charged into system and note shut off point.
5. Open charging cylinder valve slowly and allow proper charge to enter system.
6. As soon as refrigerant in sight glass has gone down to predetermined level, close charging cylinder valve.

**WARNING**

Disconnect the charging cylinder heater at this time to prevent the cylinder pressure from exceeding its maximum limits.

7. Allow system to sit for five minutes.
8. Turn on refrigerator compressor. Run compressor for a few minutes and monitor system pressures.
9. When satisfied that the unit is operating correctly, clamp the high-side process tube with the pinch-off tool while the unit is still running.

10. Slowly open the high-side manifold gauge valve to allow the compressor to remove any refrigerant trapped in the high-side hose and the process fitting.
11. Close both of the manifold gauge valves. If the high-side gauge reading rises, the pinch-off must be corrected before proceeding.
12. Remove the high-side process tube adaptor and solder the process tube closed.
13. Clamp the low-side process tube with the pinch-off tool while the unit is running. Remove the low-side process tube adaptor and solder the process tube closed.
14. Check the process tubes for refrigerant leaks.

Final Leak Test

1. With the refrigerator turned OFF leak test all low-side system components.
2. Turn the unit ON and run until the condenser is warm. Leak test the high-side system components.

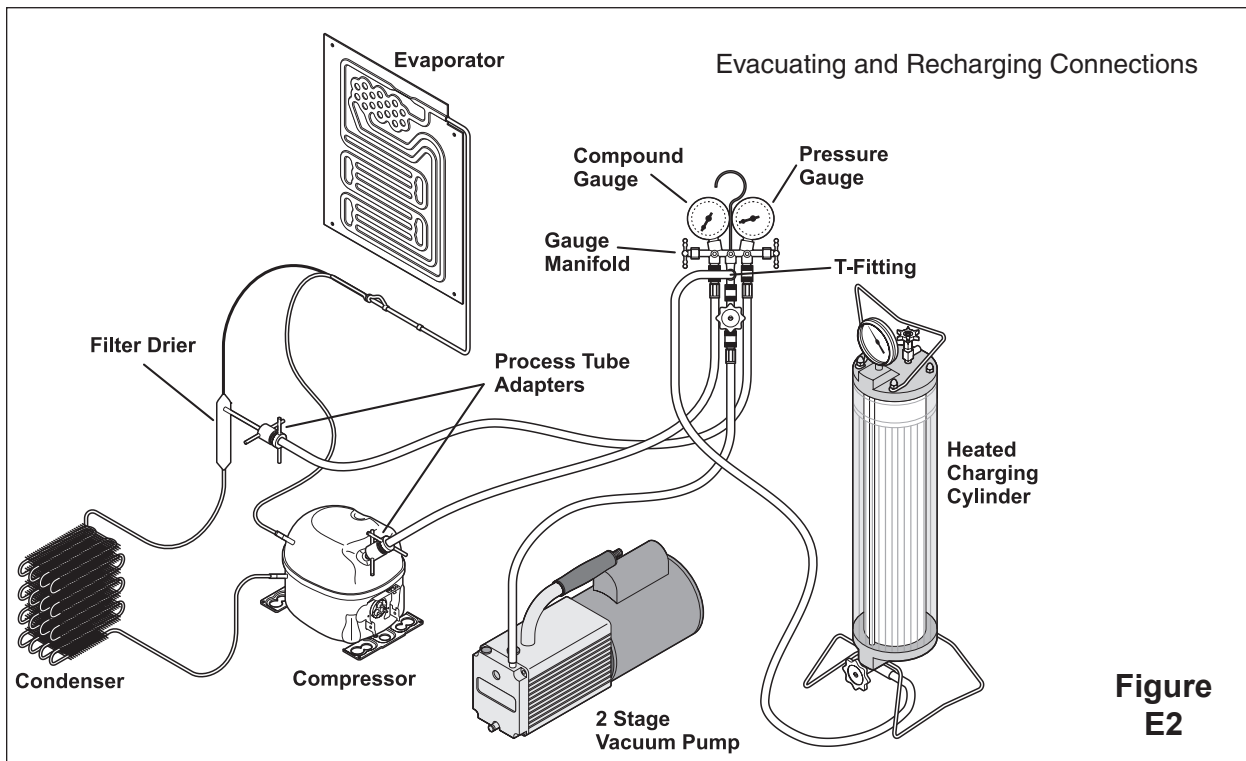

Figure E2

**NOTICE**

Instructions given here are furnished as a guide. Persons attempting to use these instructions to make repairs to the sealed refrigeration system should have a working knowledge of refrigeration and previous training on sealed system repair.

Verify Refrigerant Type In The System**CAUTION**

R-134a and R-12 are completely incompatible. Before starting any sealed system repair, it is extremely important to check serial plate of product to verify the type of refrigerant in the system.

Dedicated Equipment

R-134a must not be mixed with other types of refrigerants. R-134a must be recovered in dedicated and properly identified recovery bags and tanks.

It will be necessary to check with the manufacturer of your recovery equipment to determine R-134a compatibility. Some recovery equipment manufacturers have changeover instructions for switching between refrigerant types. Protect yourself and your equipment by following all manufacturer guidelines.

Also, ensure that your refrigeration hoses are specified for use with R-134a refrigerant. Research has shown that compounds in standard refrigeration hoses may enter sealed systems and ultimately restrict the cap tube in an R-134a system.

R-134a Refrigeration Systems

The sealed refrigeration system will consist of the same basic components being utilized in the R-12 systems.

There is a 10% to 15% discharge pressure increase using R-134a, with a 5% to 10% decrease in suction pressure when compared to the same product with an R-12 system operating at 90°F (32°C) ambient temperature conditions. Lower suction pressures result from the lower density of R-134a refrigerant which effects refrigerant flow rate. R-134a systems commonly operate in a 1"-2" vacuum on the suction side.

Products using R-134a refrigerant will generally have a longer capillary tube to maintain a similar flow rate and some models will have a larger condenser to reduce the discharge pressures and lower start-up sound transmission.

Miscibility of R-134a and Ester Oil

A special synthetic oil known as Ester oil is used as a lubricant in refrigeration systems operating on R-134a. Ester oils are produced from alcohols and fatty acids and are available in several different variants. Ester oils have a pleasant aroma reminiscent of fruit.

Ester oils generally include various types of additives for improving certain properties such as viscosity, temperature sensitivity, etc. These additives are often aggressive, and skin contact with Ester oils should therefore be avoided.

One of the most important requirements made on a refrigerant system is that the oil mix with the refrigerant. Since mineral oil and ordinary synthetic oil DO NOT mix with R-134a, Ester oil is used for lubrication. Ester oil dissolves in R-134a.

Ester oil is broken down by chlorine and cannot be used with R-12 (R-12 contains chlorine) or any other compound containing chlorine. Therefore, R-134a refrigeration systems have virtually no tolerance for chlorine molecules from CFC refrigerants (R-134a is an HFC and contains no chlorine).

**CAUTION**

During R-134a service, it is extremely important to avoid using equipment that may contain residual amounts of mineral oil, CFC's or HCFC's which could enter and contaminate the sealed system.

For example, hoses that were used for a refrigeration system operating on R-12 may contain small quantities of mineral oil which can block the capillary tube in a system operating on R-134a. As little as one milligram may be sufficient to cause a blockage. In addition, sealed system components that have been used with CFC systems must not be used with R-134a systems. These components may contain residual amounts of refrigerant and oil which could damage an R-134a system.

At the earliest stage of development work on R-134a, tests were carried out on a different type of synthetic oil known as Poly-Alkaline Glycol (PAG). This oil is also used in certain air conditioning systems for cars. PAG and Ester oil DO NOT mix with one another. Service equipment used for R-134a / Ester oil must not come into contact with PAG.

Water In The Refrigeration System

Even in very small quantities, water in any refrigeration system can cause the following problems:

- Ice plugs in capillary tubes.
- Copper plating in compressor.
- Reactions with organic materials in systems.
- Corrosion of metals.

R-134a and Ester oil will aggravate the problem of water in the refrigeration system. Ester oil may react with water vapor and is hygroscopic (it will absorb water if it comes in contact with humid air). Water is also more soluble in R-134a than R-12.

To minimize the water content whenever service work is performed, the refrigeration system should always be thoroughly evacuated through process tube adaptors on both the high and low sides of the system. Evacuation must be for a minimum of 30 minutes to at least a 29.9 inch (500 micron) vacuum.

VACUUM CHART		
Vacuum Inches Hg.	Microns	Boiling Point of Water °F
28.940	25000	77.9
29.530	10000	52.0
29.832	4600	32.0
29.882	1000	1.0
29.901	500	-11.2
29.915	150	-32.8
29.917	100	-38.2
29.919	50	-49.0

To achieve the required 29.9 inch (500 micron) vacuum, a properly maintained two-stage vacuum pump in good condition is required. A two stage pump can reach a deeper vacuum than a single stage because the exhaust from the first pumping stage is discharged into the second pumping stage. This means the second stage begins pumping at a lower pressure so a lower ultimate vacuum can be achieved (See 2-Stage Vacuum Pump, Figure E3).

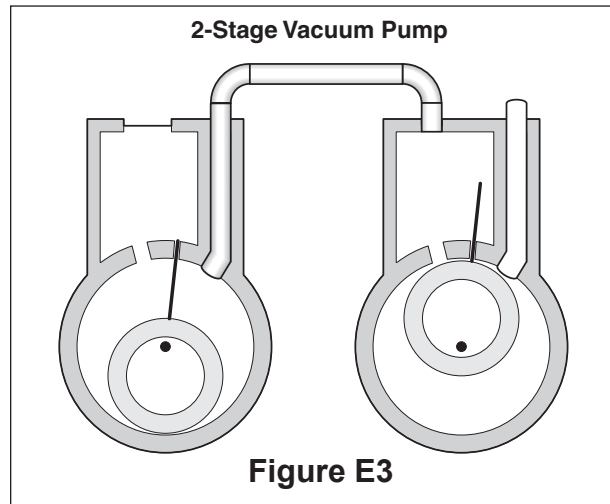

Vacuum Pump Maintenance

It is absolutely essential to maintain your vacuum pump according to the manufacturer's instructions including required oil changes at the recommended intervals. Vacuum pump oil should always be changed after evacuating a contaminated system. Vacuum pump performance should be checked periodically with a micron gauge.

Vacuum pump suppliers may or may not recommend changing the vacuum pump oil to the same type that's in the system being evacuated. Some manufacturers may recommend a vacuum pump that's dedicated to R-134a systems.

Robinair has stated that their current and discontinued vacuum pump models, using mineral oil currently specified for use in their vacuum pumps, can be used to evacuate R-134a/Ester oil systems. Robinair also states that it is acceptable to alternate between evacuating R-12/mineral oil and R-134a/Ester oil systems without adversely effecting the vacuum pump's performance.

For other brands of vacuum pumps, check with the manufacturer for restrictions and guidelines when using with R-134a.

⚠ CAUTION

If you use a vacuum pump with mineral oil to evacuate an R-134a system, it is **ABSOLUTELY ESSENTIAL** to have a shut-off valve between pump and your manifold gauge set as shown in Figure E2. The hand valve must be closed during all times when vacuum pump is not operating. This will prevent migration of mineral oil vapor into R134a/Ester oil system. If vacuum pump should stop during evacuation for any reason, the hand pump shut-off valve must be closed immediately.

Refrigerant Leaks

A system with R-134a and Ester oil will become saturated with moisture much faster than a system with R-12 and mineral oil. If your leak was in the low side of the refrigeration system when the compressor is running the pressure in the low side will go into a vacuum. As additional refrigerant leaks out the system will go deeper into a vacuum. The system running in this vacuum will allow air and moisture to be pulled into the sealed system. The moisture pulled in can then be mixed in to the Ester oil in the compressor.

If the product has had a low side leak you will need to install the two stage service dryer filter part

number 5303918288. You must heat the crankcase area of the compressor using a heat gun on the high heat setting though out the 30 minutes you are running your vacuum pump to pull a vacuum on the system. Every 4 to 5 minutes while you are running your vacuum pump and heating the crankcase area shake the compressor. By heating the crankcase you are heating the oil in the compressor. This will drive the moisture out of the oil. By shaking the compressor this will allow the moisture to come to the top of the oil faster so the vacuum pump can remove the moisture from the system.

Electrolux Home Products does not approve the use of the Sweep Charge for sealed system repair. This method of servicing sealed systems we know is often used to repair products in the field. The Sweep Charge does not adequately remove the moisture from the oil in the compressor. In a R-134a system you will need to replaced the compressor if the product has had a low side leak and you are servicing with the Sweep Charge procedure.

R-134a refrigerant molecules are smaller than R-12 molecules. This means that R-134a will pass more minor leaks and the rate of flow will be greater than for R-12. Therefore, it is now more important than ever to follow good brazing practices. Use a good grade of silver solder. 45% silver solder is recommended.

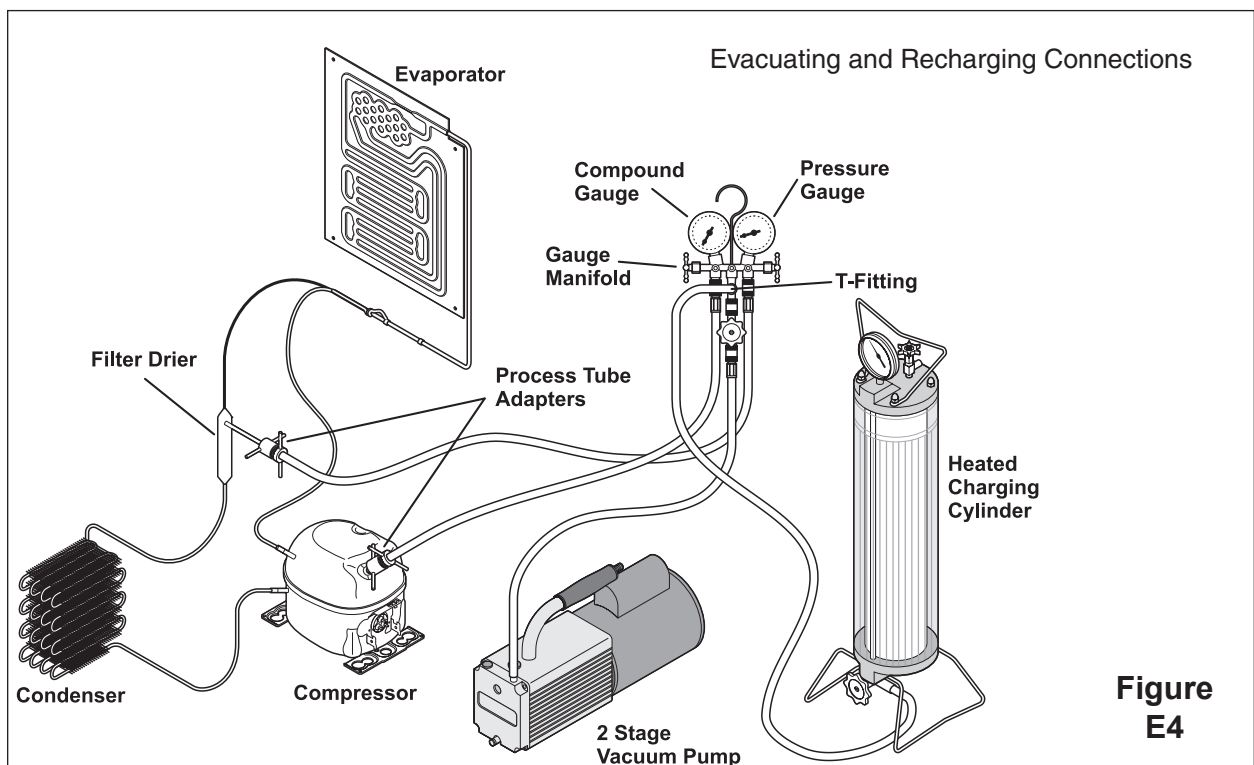

Figure E4

Leak Detection

R-134a system leaks can be pinpointed by means of an electronic leak detector or by bubble solution.

Electronic leak detectors for R-134a service are currently available from several manufacturers. The least expensive models are non-selective detectors that will detect any type of emission or vapor present, regardless of its chemical composition. Some non-selective detectors designed for use with R-12 may have a much lower sensitivity when used with R-134a. However, newly designed detectors with good R-134a sensitivity are now available. Be sure to consult with the manufacturer before selecting or using a non-selective detector with R-134a.

Halogen-specific detectors use a specialized sensor that allows detection of compounds containing chlorine, fluorine, bromine, and iodine without being activated by other species. The major advantage of this type of detector is a reduction in the number of “nuisance alarms”. Halogen-specific detectors are generally more expensive than non-selective detectors but feature higher sensitivity.

R-134a properties

The properties of R-134a are very similar to those of R12. The principal data for the two refrigerants are shown in the chart below.

	REFRIGERANTS	
	R-12	R-134a
NAME	Dichlorodifluoromethane	1,1,1,2--Tetrafluoromethane
Formula	CCl_2F_2	$\text{CH}_2\text{F}-\text{CF}_3$
Molecular Weight (g/mol)	120.93	102.3
Ozone Depletion Potential (ODP)	1	0
Global Warming Potential (GWP)	3.1	0.3
Boiling Point °F	-21.6	-15.7
Vapor Pressure (77°F)	80 psig	82 psig
Flammability	None	None
Solubility of Water in Refrigerant (wt% @ 77°F)	0.009	0.11

HFC-134a, CFC-12 Pressure Temperature Chart

°F	°C	HFC-134a	CFC-12		°F	°C	HFC-134a	CFC-12
-60	-51.1	21.8*	19.0*		55	12.8	51.1	52.0
-55	-48.3	20.4*	17.3*		60	15.6	57.3	57.7
-50	-45.6	18.7*	15.4*		65	18.3	63.9	63.8
-45	-42.8	16.9*	13.3*		70	21.1	70.9	70.2
-40	-40.0	14.8*	11.0*		75	23.9	78.4	77.0
-35	-37.2	12.5*	8.4*		80	26.7	86.4	84.2
-30	-34.4	9.8*	5.5*		85	29.4	94.9	91.8
-25	-31.7	6.9*	2.3*		90	32.2	103.9	99.8
-20	-28.9	3.7*	0.6		95	35.0	113.5	108.3
-15	-26.1	0.0	2.4		100	37.8	123.6	117.2
-10	-23.3	1.9	4.5		105	40.6	134.3	126.6
-5	-20.6	4.1	6.7		110	43.3	145.6	136.4
0	-17.8	6.5	9.2		115	46.1	157.6	146.8
5	-15.0	9.1	11.8		120	48.9	170.3	157.7
10	-12.2	12.0	14.6		125	51.7	183.6	169.1
15	-9.4	15.0	17.7		130	54.4	197.6	181.0
20	-6.7	18.4	21.0		135	57.2	212.4	193.5
25	-3.9	22.1	24.6		140	60.0	227.9	206.6
30	-1.1	26.1	28.5		145	62.8	244.3	220.3
35	1.7	30.4	32.6		150	65.6	261.4	234.6
40	4.4	35.0	37.0		155	68.3	279.5	249.5
45	7.2	40.0	41.7		160	71.1	298.4	265.1
50	10.0	45.3	46.7		165	73.9	318.3	281.4

Inhalation Toxicity

HFC-134a poses no acute or chronic hazard when it is handled in accordance with DuPont recommendations and when exposures are maintained at or below the DuPont Acceptable Exposure Limit (AEL) of 1,000 ppm (8 and 12 hour Time-Weighted Average or TWA).

An AEL is an airborne exposure limit established by DuPont scientists that specifies time-weighted average (TWA) airborne concentrations to which nearly all workers may be repeatedly exposed without adverse effects. The AEL for HFC-134a has the same value as the Threshold Limit Values (TLVs) established for CFC-12 and HCFC-22. TLVs are established by the American Conference of Governmental and Industrial Hygienists (ACGIH).

However, inhaling high concentrations of HFC-134a vapor may cause temporary central nervous system depression with narcosis, lethargy and anesthetic effects. Other effects that may occur include dizziness, a feeling of intoxication and a loss of coordination. Continued breathing of high concentrations of HFC-134a vapors may produce cardiac irregularities (cardiac sensitization), unconsciousness, and with gross overexposure, death. Intentional misuse or deliberate inhalation of HFC-134a may cause death without warning. This practice is **extremely dangerous**.

If you experience any of the initial symptoms, move to fresh air and seek medical attention.

Cardiac Sensitization

If vapors are inhaled at a concentration of 75,000 ppm, which is well above the AEL, the heart may become sensitized to adrenaline, leading to cardiac irregularities and, possibly, to cardiac arrest. The likelihood of these cardiac problems increases if you are under physical or emotional stress.

Medical attention must be given immediately if exposed to high concentrations of HFC-134a. **DO NOT** treat with adrenaline (epinephrine) or similar drugs. These drugs may increase the risk of cardiac arrhythmias and cardiac arrest. If the person is having difficulty breathing, administer oxygen. If breathing has stopped, give artificial respiration.

Spills or Leaks

If a large release of vapor occurs, such as from a large spill or leak, the vapors may concentrate near the floor or low spots and displace the oxygen available for breathing, causing suffocation.

Evacuate everyone until the area has been ventilated. Use blowers or fans to circulate the air at floor level. **DO NOT** reenter the affected area unless you are equipped with a self-contained breathing apparatus or unless an area monitor indicates that the concentration of HFC-134a vapors in the area is below the AEL.

Always use self-contained breathing apparatus or an air-line mask when entering tanks or other areas where vapors might exist. Use the buddy system and a lifeline. Refer to the Material Safety Data Sheet (MSDS) for HFC-134a for more information.

HFC-134a vapors have a slightly sweet odor that can be difficult to detect. Therefore, frequent leak checks and the installation of permanent area monitors may be necessary in enclosed spaces. Refer to ASHRAE Standards 15 and 34 for refrigeration machinery rooms.

To ensure safety when working with HFC-134a in enclosed areas:

1. Route relief and purge vent piping (if present) outdoors, away from air intakes.
2. Make certain area is well ventilated, using auxiliary ventilation, if necessary, to move vapors.
3. Make sure area is clear of vapors prior to beginning work.
4. Install air monitoring equipment to detect leaks.

Skin and Eye Contact

At room temperature, HFC-134a vapors have little or no effect on the skin or eyes. However, in liquid form, HFC-134a can freeze skin or eyes on contact, causing frostbite. Following contact, soak the exposed area in lukewarm water, not cold or hot. If medical treatment cannot begin immediately, apply a light coat of a nonmedicated ointment, such as petroleum jelly. If the exposed area is in a location where the presence of the ointment would be awkward, such as on the eye, apply a light bandage. In all cases of frostbite, seek medical attention as soon as possible.

Always wear protective clothing when there is a risk of exposure to liquid HFC-134a. Where splashing is possible, **always** wear eye protection and a face shield.

Combustibility of HFC-134a

HFC-134a is nonflammable at ambient temperatures and atmospheric pressure. However, tests have shown HFC-134a to be combustible at pressures as low as 5.5 psig (139.3 kPa absolute) at 177°C (350°F) when mixed with air at concentrations generally greater than 60% volume air. At lower temperatures, higher pressures are required for combustibility. (HCFC-22 is also combustible at pressures above atmospheric in the presence of high air concentrations). Test results and calculations have shown:

- At ambient temperature, all concentrations of HFC-134a in air are nonflammable at pressures below 15 psig (205 kPa absolute).
- Combustible mixtures of air and HFC-134a will not form when liquid HFC-134a is pumped into closed vessel if initial air pressure in vessel is limited to one atmosphere absolute and final pressure is limited to 300 psig (2,170 kPa absolute). If initial air pressure is greater than one atmosphere, combustible mixtures may form as tank is filled.

Based on above information, the following operating practices are recommended:

Leak Testing

- Equipment should **NEVER** be leak tested with a pressurized mixture of HFC-134a and air. HFC-134a may be safely pressured with dry nitrogen.

Bulk Delivery and Storage

- Tanks should normally be evacuated at start of filling, and should never be filled while under positive air pressure.
- Tank pressure should never be allowed to exceed 300 psig (2,170 kPa) when filling with HFC-134a. Relief devices on either tanks or HFC-134a supply system usually prevent this.
- Tank pressures should be monitored routinely.
- Air lines should never be connected to storage tanks.

Filling and Charging Operations

- Before evacuating cylinders or refrigeration equipment, any remaining refrigerant should be removed by recovery system.
- Vacuum pump discharge lines should be free of restrictions that could increase discharge pressures above 15 psig (205 kPa) and result in formation of combustible mixtures.
- Cylinders or refrigeration equipment should normally be evacuated at start of filling, and should never be filled while under positive air pressure.
- Final pressures should not exceed 300 psig (2,170 kPa).
- Filled cylinders should periodically be analyzed for air (nonabsorbable gas or NAG).

Refrigerant Recovery Systems

Efficient recovery of refrigerant from equipment or containers requires evacuation at the end of the recovery cycle. Suction lines to a recovery compressor should be periodically checked for leaks to prevent compressing air into the recovery cylinder during evacuation. In addition, the recovery cylinder pressure should be monitored, and evacuation stopped in the event of a rapid pressure rise indicating the presence of noncondensable air. The recovery cylinder contents should then be analyzed for NAG, and the recovery system leak checked if air is present. **DO NOT** continue to evacuate a refrigeration system that has a major leak.

Thermal Decomposition

HFC-134a vapors will decompose when exposed to high temperatures from flames or electric resistance heaters. Decomposition may produce toxic and irritating compounds, such as hydrogen fluoride. The pungent odors released will irritate the nose and throat and generally force people to evacuate the area. Therefore, it is important to prevent decomposition by avoiding exposure to high temperatures.

SYSTEM DIAGRAM

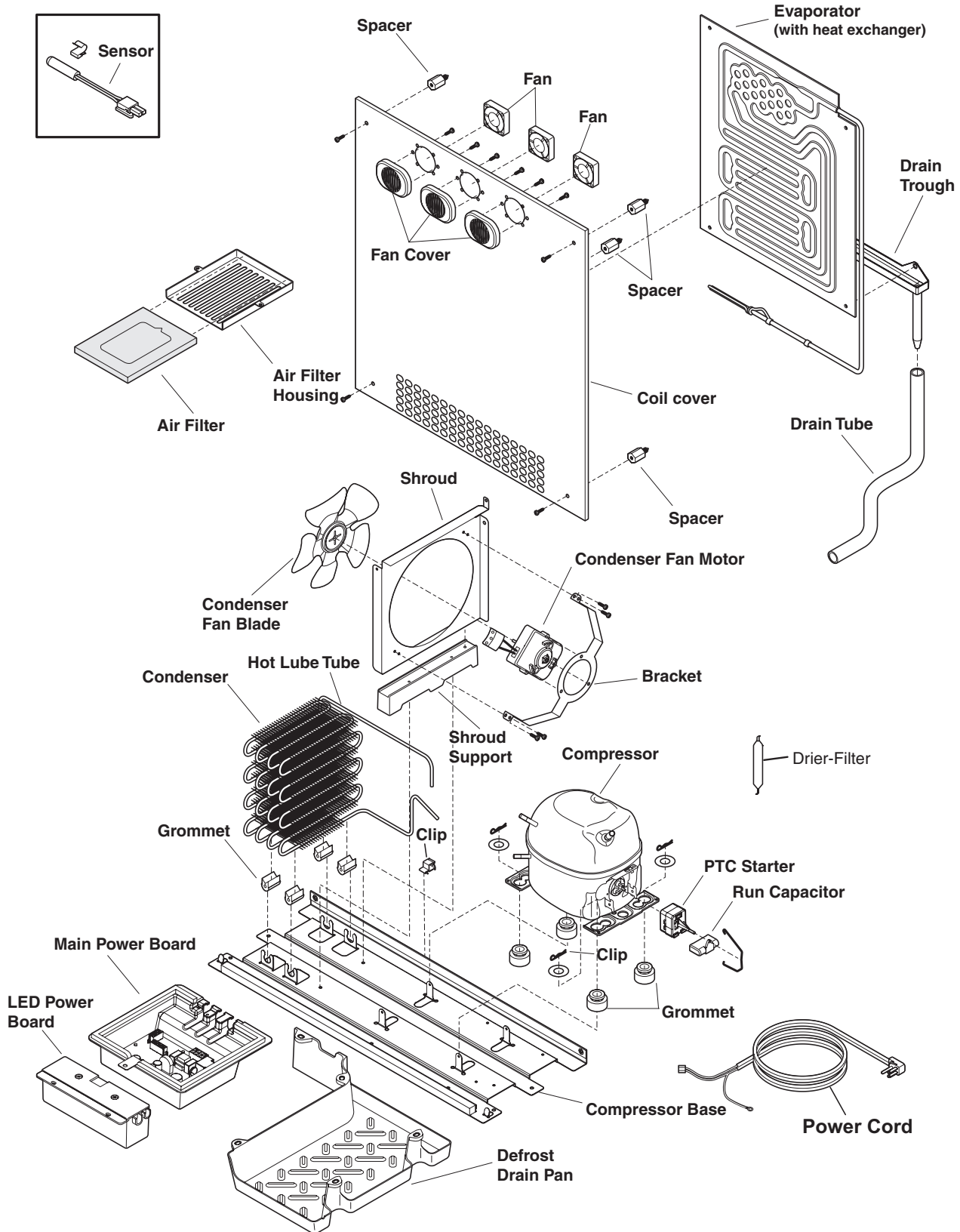

DOOR DIAGRAM

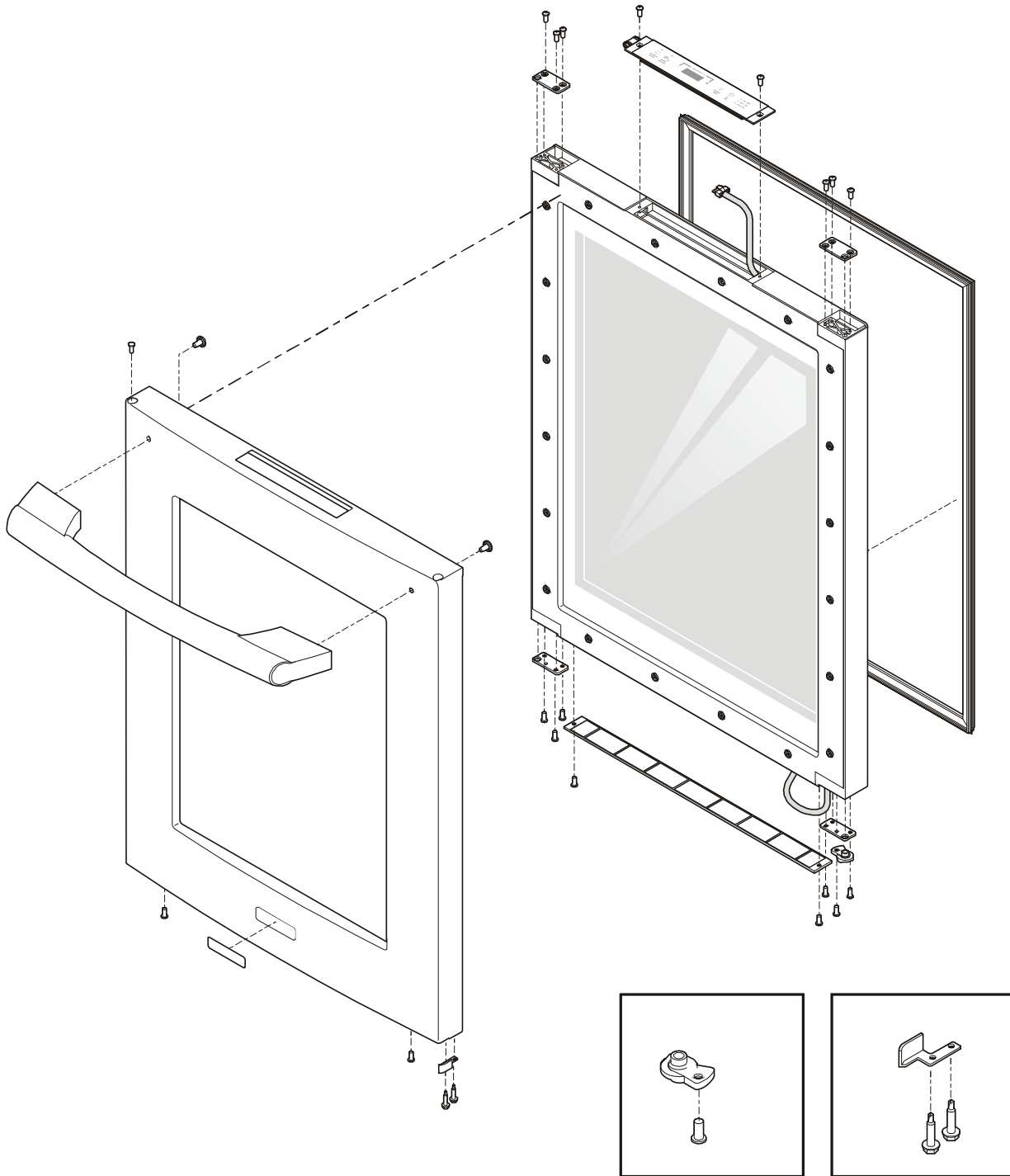

Disassembly - Evaporator Fan Motors

1. Disconnect power source to drawers.
2. Remove top drawer by fully extending it.
3. Disconnect Molex® connector.
3. Remove two screws using Phillips® screwdriver.
4. Remove drawer by sliding forward 1/2" and pull up.

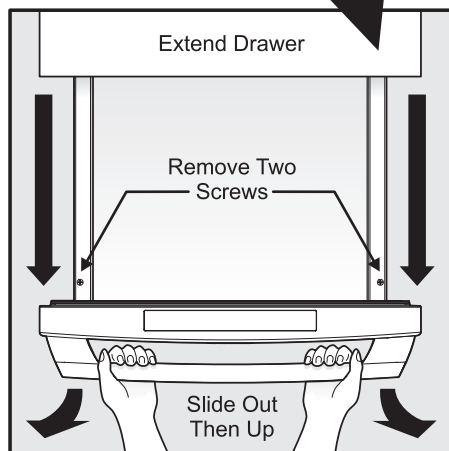
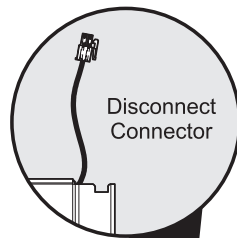

5. Remove bottom drawer in same manner.

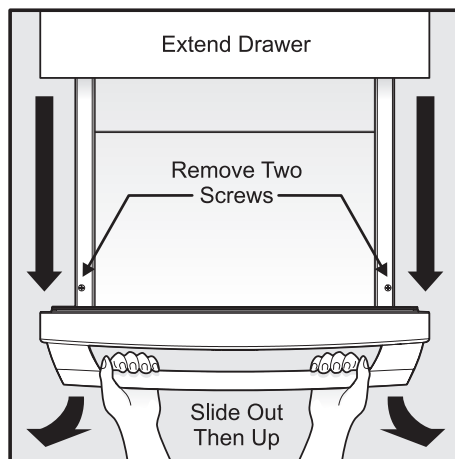

6. Remove four screws on evaporator cover. Pull cover outward to gain access to the fan motors.

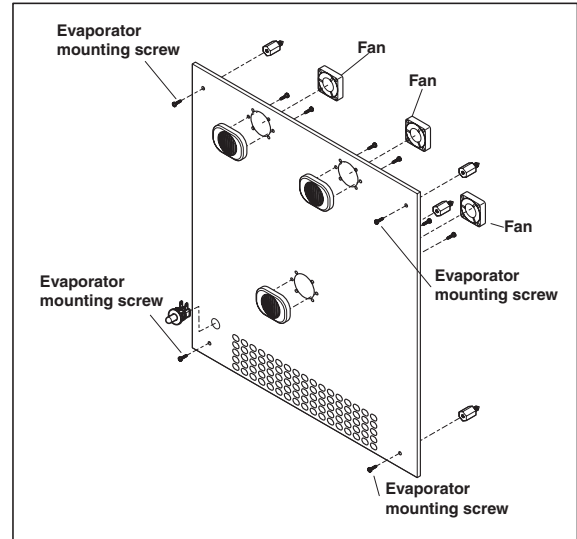

Disassembly - User Interface (UI)

To remove the User Interface board (UI):

1. Disconnect power source to drawers.
2. Slide out top drawer.
3. Remove two (2) screws from underside of front panel.
4. Slide off panel from bottom to top. This will give you access to the UI.

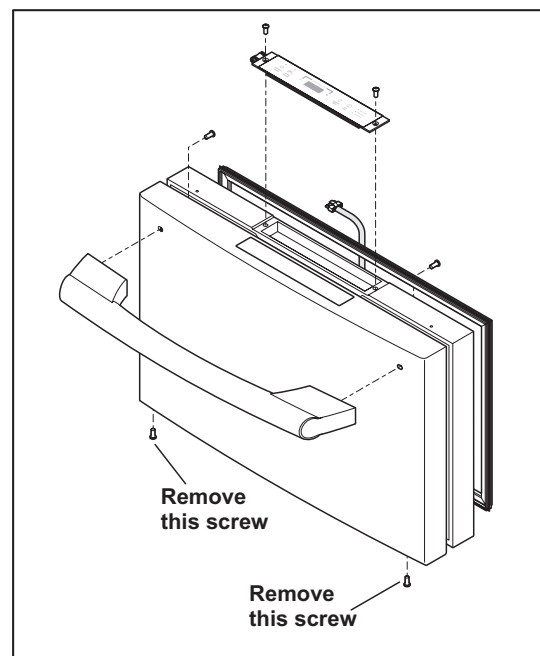

LED Lighting

Four (4) LED's, wired in series, make up the lighting. Two are located in the center mullion for the bottom drawer and two are located at the top of the interior. The LED's are powered by the LED power supply located under the unit behind the toe grille.

An internal magnet in the cabinet mates with the UI in the top drawer to turn the LED's on and off. There is also a light switch located on the lower left side on the rear of the evaporator for the bottom drawer when opened.

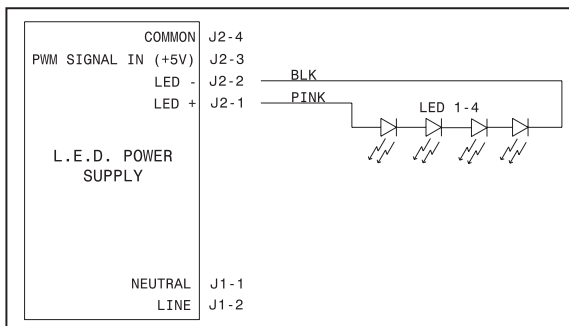

Main PCB

The main PCB is located under the unit behind the toe grille.. It will be necessary to pull out the unit (if built in) and lean back to gain access.

The power supply for the interior lighting LED's is located in front of the main PCB.

Sealed System

Refer to Section "E" Refrigeration for sealed system information.

Diagnostics / Service Mode

To enter the Service Mode, press and hold the **vacation mode** key, while pressing the **on/off** key 3 times in 5 seconds. Temperature digit display will show (1). Each press of the left hand temperature UP (+) or left hand temperature DOWN (-) key will step through the service tests, (1) through (6). Press the **mute sounds** key to access the test selected. Once the test is accessed the display will show "o" and each press of the temperature UP (+) key will cycle forward through the test features (A-E) and display the test information in the display. Each press of the temperature DOWN (-) key will cycle back through the test features. Pressing the **mute sounds** key will exit from the test and display the current service test number.

Diagnostic Tests

- #1 **Firmware Version** - displays firmware version of main PCB and UI boards
- #2 **Evaporator Fan** - Toggles the evaporator fan(s) on and off.
- #3 **Primary Sensor**
Will display: "P1" Normal
"P2" Open
"P3" Shorted
- #4 **Evaporator Sensor**
Will display: "E1" Normal
"E2" Open
"E3" Shorted
- #5 **Compressor** - toggles the compressor on and off.
- #6 **LED Display Test** - Illuminates display LED's.
- #7 **Exit Service Mode** - hold left temperature (+) key for 5 seconds to exit service mode.

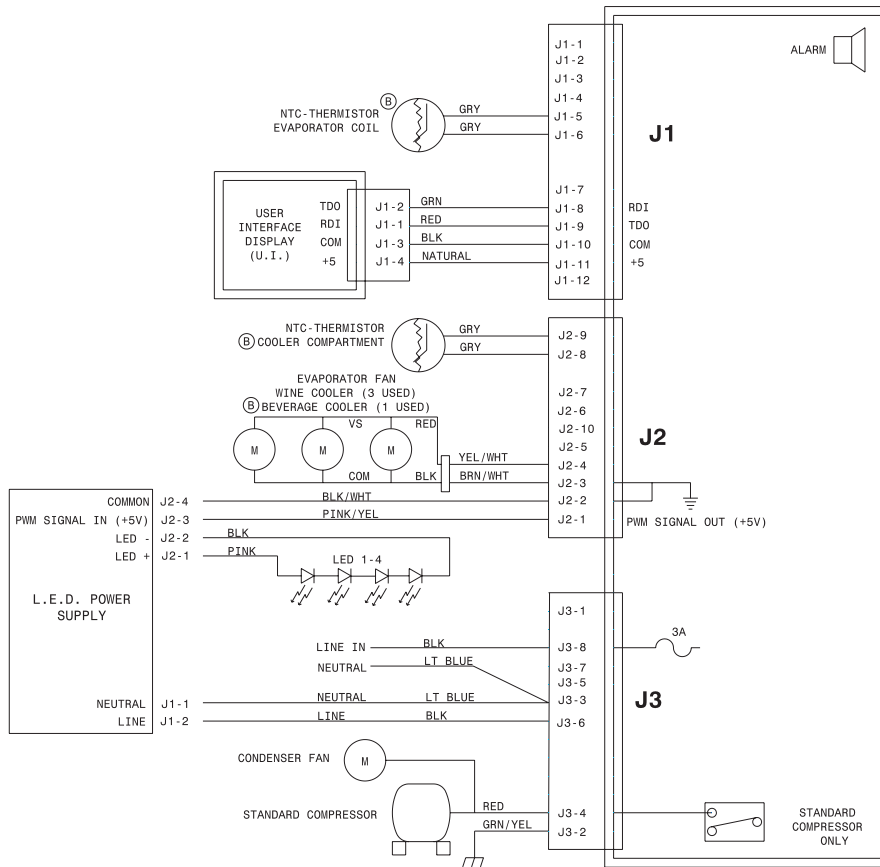

 **Electrolux**

