



CONSUMER SERVICES TECHNICAL
EDUCATION GROUP PRESENTS

R-92

WHIRLPOOL & KITCHENAID IN-DOOR ICE SYSTEM



JOB AID
Part No. 4322658A

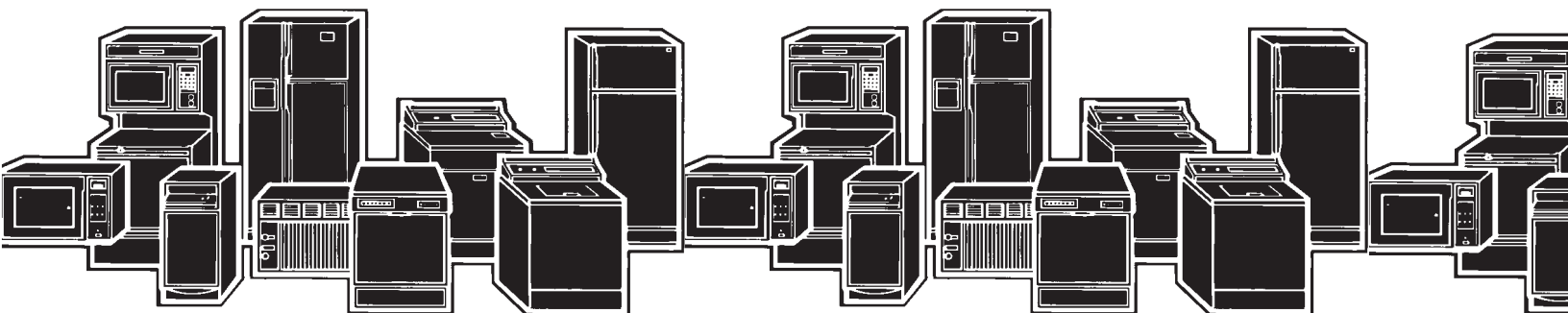

FORWARD

This Job Aid, “Whirlpool & KitchenAid In-Door Ice System,” (Part No. 4322658A), provides the technician with information on the operation and service of the Whirlpool & KitchenAid In-Door Ice System. It is to be used as a training Job Aid and Service Manual. For specific information on the model being serviced, refer to the “Use and Care Guide,” or “Tech Sheet” provided with the Refrigerator/Freezer.

The Wiring Diagrams used in this Job Aid are typical and should be used for training purposes only. Always use the Wiring Diagram supplied with the product when servicing the unit.

GOALS AND OBJECTIVES

The goal of this Job Aid is to provide detailed information that will enable the service technician to properly diagnose malfunctions and repair the In-Door Ice System.

The objectives of this Job Aid are to:

- Understand and follow proper safety precautions.
- Successfully troubleshoot and diagnose malfunctions.
- Successfully perform necessary repairs.
- Successfully return the In-Door Ice System to proper operational status.

WHIRLPOOL CORPORATION assumes no responsibility for any repairs made on our products by anyone other than Authorized Service Technicians.

TABLE OF CONENTS

	Page
GENERAL	1-1
Safety First.....	1-1
PRODUCT INTRODUCTION	2-1
Overview.....	2-1
THEORY OF OPERATION	3-1
COMPONENT ACCESS	4-1
Component Locations.....	4-1
Removing The Ice Maker & The Water Fill Tube.....	4-2
Removing The Emitter & Receiver Modules.....	4-5
Removing & Reinstalling The Motor.....	4-6
Accessing The Selector Switch Pack & Dispenser Switches.....	4-9
DIAGNOSTICS & TROUBLESHOOTING	5-1
Diagnostics.....	5-1
Optics Diagnostics Mode.....	5-1
Optics Diagnostics For Original Design Boards.....	5-2
Optics Diagnostics For 2002 Design Boards.....	5-4
Component Diagnostics Mode.....	5-5
Optics Diagnostics Mode Charts.....	5-6
Component Diagnostics Mode Chart.....	5-7
Troubleshooting Chart A—Original Optics Design.....	5-8
Troubleshooting Chart B—2002 Optics Design.....	5-9
Troubleshooting Chart C—Component Diagnostics Mode.....	5-10
Troubleshooting The Motor.....	5-11
WIRING DIAGRAMS & STRIP CIRCUITS	6-1
Whirlpool Wiring Diagram.....	6-1
KitchenAid Wiring Diagram.....	6-2
Strip Circuits.....	6-3
CONFIRMATION OF LEARNING EXERCISES	7-1

— NOTES —

GENERAL SAFETY FIRST

Your safety and the safety of others is very important.

We have provided many important safety messages in this Job Aid and on the appliance. Always read and obey all safety messages.



This is the safety alert symbol.

This symbol alerts you to hazards that can kill or hurt you and others.

All safety messages will follow the safety alert symbol and either the word “DANGER” or “WARNING.” These words mean:

! DANGER

You can be killed or seriously injured if you don't immediately follow instructions.

! WARNING

You can be killed or seriously injured if you don't follow instructions.

All safety messages will tell you what the potential hazard is, tell you how to reduce the chance of injury, and tell you what can happen if the instructions are not followed.

ELECTRICAL POWER SUPPLY & GROUNDING REQUIREMENTS

! WARNING



Electrical Shock Hazard

Disconnect power before servicing.
Replace all panels before operating.
Failure to do so can result in death or electrical shock.

! WARNING



Electrical Shock Hazard

Plug into a grounded 3-prong outlet.
Do not remove ground prong.
Do not use an adapter.
Do not use an extension cord.
Failure to follow these instructions can result in death, fire, or electrical shock.

⚠ WARNING



Electrical Shock Hazard

Connect green ground wire to ground screw.

Failure to do so can result in death or electrical shock.

IMPORTANT

Electrostatic Discharge (ESD) Sensitive Electronics

ESD problems are present everywhere. ESD may damage or weaken the electronic control assembly. The new control assembly may appear to work well after repair is finished, but failure may occur at a later date due to ESD stress.

- Use an antistatic wrist strap. Connect the wrist strap to the green ground connection point, or to an unpainted metal surface in the appliance.

- OR -

- Touch your finger repeatedly to a green ground connection point, or to an unpainted metal surface in the appliance.
- Before removing the part from its package, touch the antistatic bag to a green ground connection point, or to an unpainted metal surface in the appliance.
- Avoid touching electronic parts, or terminal contacts. Handle the electronic control assembly by the edges only.
- When repackaging the failed electronic control assembly in an antistatic bag, observe the previous instructions.

PRODUCT INTRODUCTION

OVERVIEW

The primary objective of the In-Door Ice System is to increase the usable space in the freezer compartment of the current freestanding side-by-side refrigerator/freezer. The solution is to relocate the ice maker, the ice container, and drive mechanism, and replace this eye-level volume with a cantilever shelving system. The following description is intended to relate the changes that have been made from the current side-by-side ice & water dispenser configuration. The description is divided into three categories: Ice Making, Ice Storage, & Ice Dispensing.

ICE MAKING

The ice maker module and mold have not been changed from the current models. However, the location, mounting method, air delivery, water delivery, ice stripper, and ice level shutoff have all been redesigned.

Location & Mounting

The ice maker has been relocated to the top front of the freezer liner, and has been rotated 90°. Due to code requirements, the ice maker heater area is now protected by a plastic (PVC) mounting bracket. The bracket is attached to the ice maker with three mounting screws, and is held in place by grooved tracks on either side of the freezer liner.

Air Delivery

Air is delivered to the ice maker mold through a duct. This duct hooks onto the rear air duct at the back of the liner, and is secured to the top of the liner with two screws. The duct directs approximately 50% of the freezer air forward to the ice maker mold. The mounting bracket, mentioned in the previous section, also serves as an air director, and directs the air that is delivered by the duct, under the mold, and allows it to escape just under the ice stripper.



Air Duct

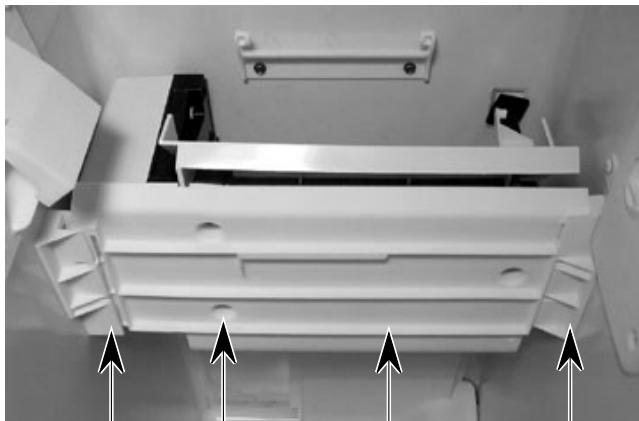

Grooved Track

Screw (1 of 3)

Mounting Bracket

Grooved Track

Water Delivery

Water is delivered to the ice maker mold by means of a “tube-within-a-tube” design. A conduit system consisting of three separate pieces (liner fitting, conduit, back panel fitting) is foamed into place in the cabinet.

This conduit provides a pathway from the freezer liner to the back panel. The majority of this system is routed above the refrigerator liner to prevent the water tubing from freezing. The tubing that delivers the water is routed through the conduit, and is secured by snapping into place at the freezer liner fitting.

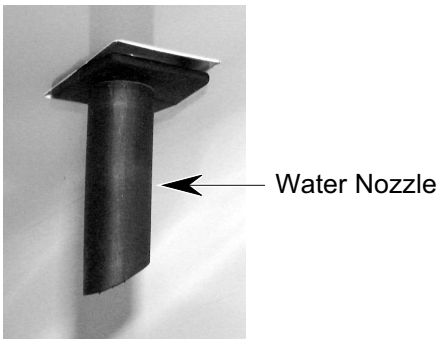

The water tube is made of polypropylene with an overmolded santoprene nozzle. Due to the rigid nature of the polypropylene, this tube is mated to a more flexible polyethylene tube with a John Guest fitting high on the back panel. This change of material is necessary to prevent kinking when the tubing is attached to the water valve.

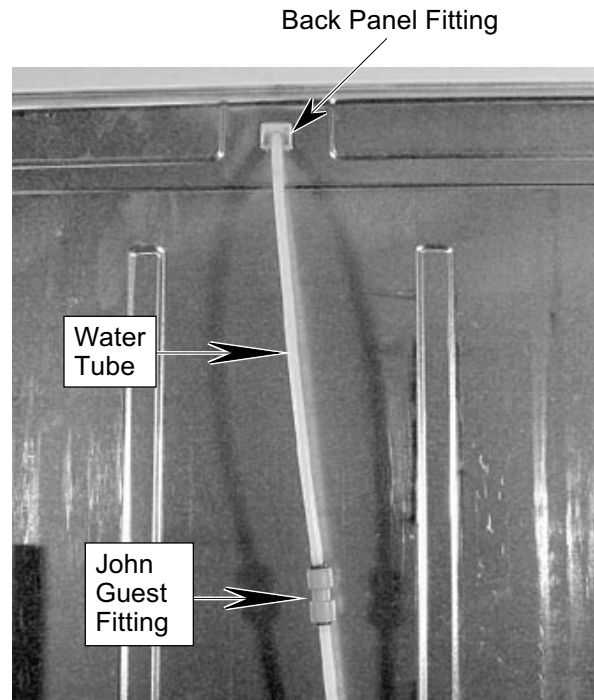
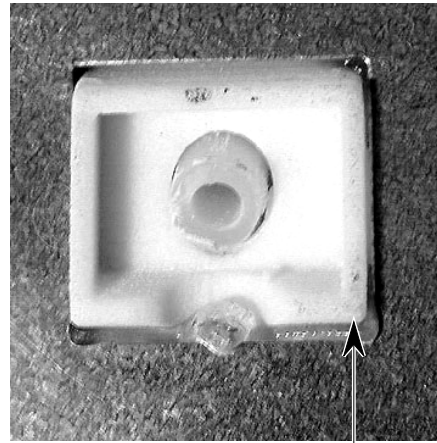

Ice Stripper

The ice stripper has been modified in order to direct ice into the new ice container. The main differences from the current stripper are: an increased ramp, and a directing wall at the fill cup end.

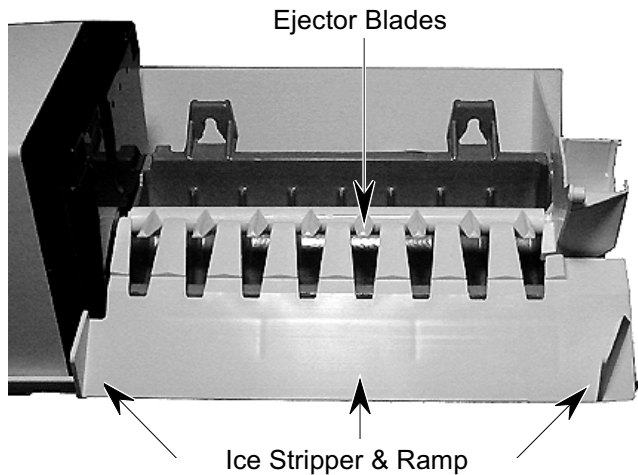

5-Cavity Ice Maker For
22 Cu. Ft. Models

Ice Level Shutoff

The mechanical shutoff arm on the older ice makers has been replaced with an electronic ice level control system. This system is located on either side of the freezer liner and utilizes infrared light technology to sense the level of ice in the door-mounted ice container. A manual shutoff option is still available on the right side of the freezer liner. This feature consists of a plastic slide that covers the receiver sensor and blocks the infrared beam.



Infrared Emitter

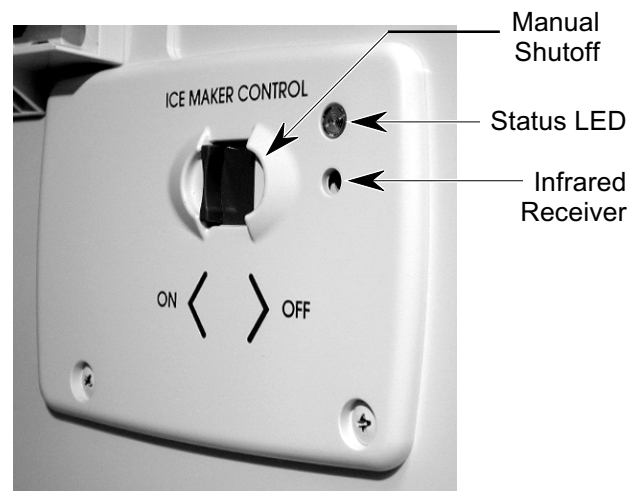

ICE STORAGE

The ice container has been redesigned and relocated to the freezer door. It is secured in place on the door liner with a sliding spring-loaded latch, mounted to a plate with two pins. The mounting plate is foamed-in-place on the door. The ice container is easily removed and replaced on the door regardless of the auger orientation.

The ice container is removed by pressing a release button on the right side and lifting. Removal instructions are printed on the container.

Other changes to the ice container consist of a vertical rod ice auger, and a clear polycarbonate upper section. The vertical orientation of the bin helps prevent “stale ice” areas, because the ice is a “first in—first out” system which helps keep the ice fresher. Also, the ice container can be completely emptied.

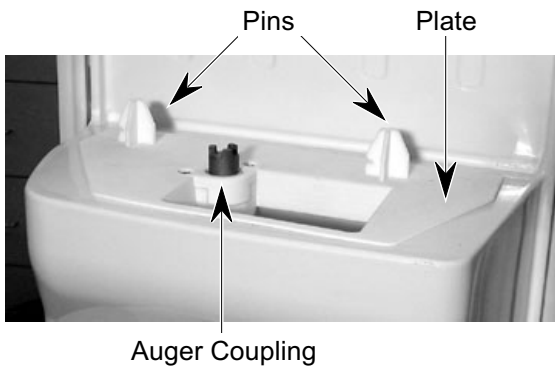
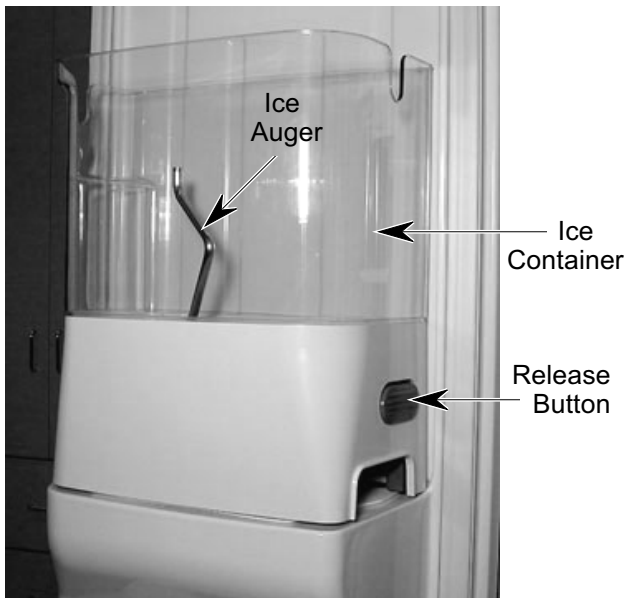

ICE DISPENSING

Major changes have been made to the power train. The motor has been redesigned and relocated to the freezer door. The cube/crush selector solenoid and its related linkage have been eliminated, and a drive shaft/spring-loaded coupling have been added.

Motor

The motor is now located on the freezer door in a foamed-in-place enclosure under the “dispenser bubble” area of the inner door panel. The motor is mounted to a plastic mounting bracket, which, in turn, is mounted to the enclosure with four mounting screws.

The motor operates on 115 volts DC (115 volts AC is delivered to the motor, where it is converted within the motor assembly to DC). This gives the motor a higher RPM than the earlier dispenser motors, and results in a faster ice delivery rate in both the cubed and crushed modes.

Crushed ice is delivered by turning the motor in a clockwise direction, and cubed ice is delivered when the motor turns in a counterclockwise direction.

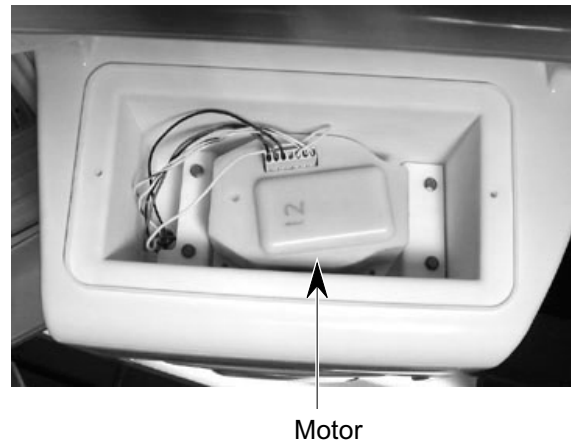

Drive Shaft / Coupling

The drive shaft / coupling connects the motor to the ice container auger. The coupling at the top of the motor drive shaft is spring-loaded to allow replacing the ice container without having to orient its coupling with the motor drive shaft coupling. If the two couplings do not en-

gage when the container is placed on the door, the motor drive shaft coupling will be depressed. The next time ice is dispensed, the motor drive shaft coupling will spring up, and engage the ice container coupling.

The original designed units use a pin that rests on a spring, located inside the drive shaft. The newly designed units have only the spring, which rests in a shallower opening at the top of the drive shaft, and eliminates the need for the pin.

On newly designed models, the hex drive shaft coupling has a skirt around it to prevent any pieces of a damaged coupling from falling down the chute.

Spring-Loaded Pin

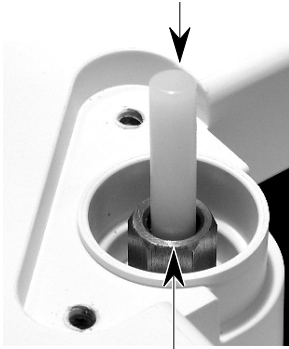

Top of Original Design Hex Drive Shaft

Spring

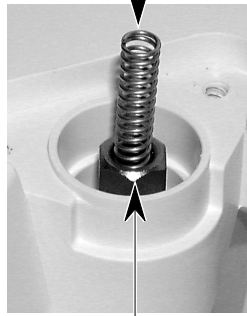

Top of Newly Designed Hex Drive Shaft

Original Hex Drive Shaft Coupling

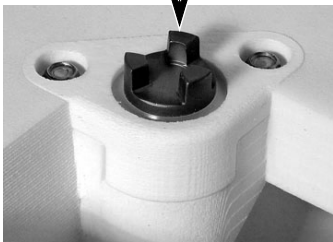

Newly Designed Hex Drive Shaft Coupling Skirt



Hex Drive Shaft



Motor

— NOTES —

THEORY OF OPERATION

The new ice making system consists of the following: an ice maker with an integrated control module, an electronic ice level sensor, an external water valve, and a freezer door compartment-mounted ice storage bin.

The ice maker control module is a stamped circuit that provides power and control for the ice making loads, which consist of the motor, heater, and water valve.

The ice harvesting process begins when the ice maker thermostat closes and signals that the harvest temperature has been reached. The closed thermostat applies power to the ice maker motor and to the heater. As the heater melts the outer layer of the ice, the motor rotates a rake, which sweeps the ice cubes out of the mold, and into the storage bin.

Due to the placement of the storage bin on the freezer door instead of on the cabinet, the sensing of the ice level is quite different from the earlier mechanical (bail arm) contact method. The mechanical arm has been replaced by an electronic control that performs this function, and two additional functions. It controls power to the ice maker, and performs system diagnostics, which includes optics diagnostics and component diagnostics.

The electronic control consists of two separate printed circuit boards mounted on opposite sides of the freezer liner just inside the door. The board mounted on the freezer door hinge-side of the cabinet is referred to as the “emitter board,” and the board mounted on the mullion side is referred to as the “receiver board.”

When the ice maker thermostat closes and signals that ice is ready to be harvested, the emitter board sends out an infrared (IR) pulse. If the path of the pulse is unobstructed to the receiver board, the phototransistor on the receiver board will “sense” the pulse. The control will then energize a relay, which applies power to the ice maker, and a harvest begins.

The ice maker loads, the motor, heater, and water valve, are still controlled by the stamped circuit module, which is part of the ice maker. The electronic control will check periodically to see if the ice maker is at the home position, (when the ejector stops at the 2 o'clock position). If the ejector is at the home position, the relay will deenergize, and remove power from the ice maker until the next harvest.

To improve functionality and reliability, some important differences exist between the new In-Door Ice system, and the earlier mechanical-type ice making systems.

The first is that a harvest can only begin if the freezer door is closed, and previous harvest conditions are also met (ejector at home). If the bin is full, and ice is removed, which lowers the ice level, it may take up to 5 minutes before a harvest starts.

To prevent an early harvest from occurring after the last harvest is completed, a minimum of 50 minutes must pass before another harvest will be initiated. Closing the receiver's shutoff slide covers the sensor and prevents the ice maker from harvesting ice.

The In-Door Ice control contains two diagnostic routines. One is an optics test, and the other is a component test. There are two optics tests: one for the original style optics, and the other for the 2002 design optics:

- 1.a) *Original Optics*—An optics circuit test is run when the freezer door switch is actuated three times, and the freezer door is closed to allow a path for the optics beam to reach the receiver.
- b) *2002 Design Optics*—An optics circuit test is run any time the freezer door is opened.
2. *Component Test*—A component test is run on power-up when the freezer door is closed.

Both routines provide visual feedback as to the result of the diagnostic. All other system enhancements are transparent during the ice making system operation.

— NOTES —

COMPONENT ACCESS

COMPONENT LOCATIONS

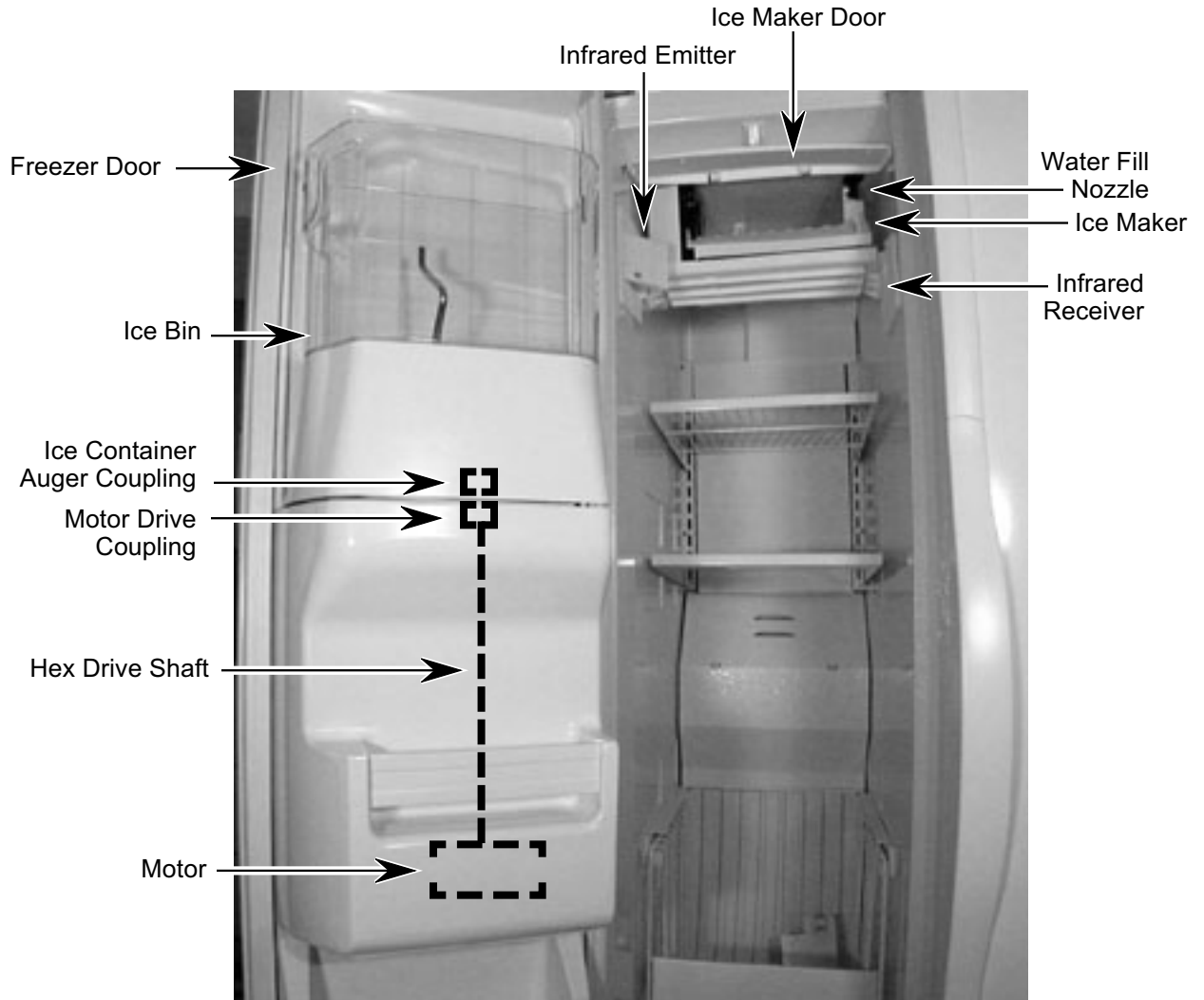

REMOVING THE ICE MAKER & THE WATER FILL TUBE

⚠ **WARNING**



Electrical Shock Hazard

Disconnect power before servicing.
Replace all panels before operating.
Failure to do so can result in death or electrical shock.

1. Disconnect the unit from the electrical supply.
2. **To remove the ice maker:**
 - a) Open the freezer door.
 - b) Close the spring-loaded emitter door and open the ice maker door.

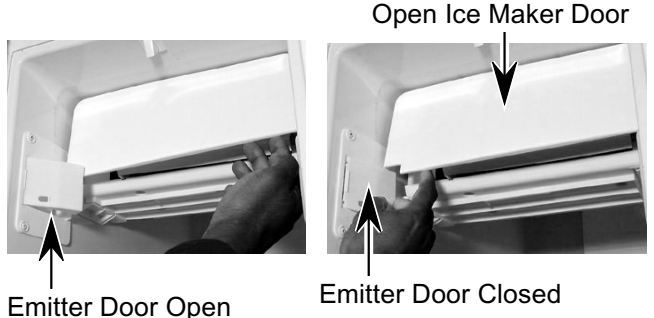

c) Push the ice maker door to the left so that the right pin disengages from the pivot arm, then lift the pin out of the pivot, and remove the left pin.

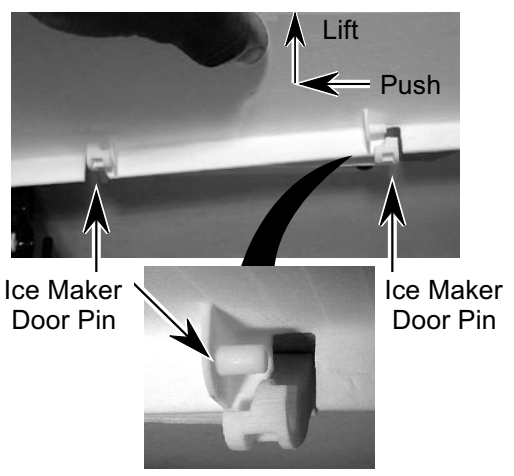

d) Remove the wire shield screw from the bottom of the ice maker.

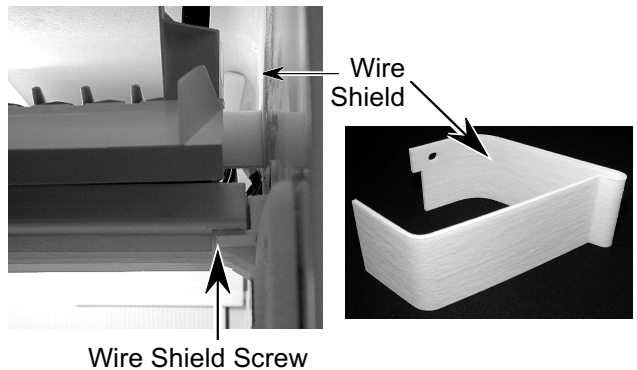

- e) From the rear of the ice maker, lift the top of the wire shield slightly and pull it back to release it from the ice maker.
- f) Press up on the two retaining clips (one on each side) at the bottom of the ice maker tracks with a fingernail of each hand, pull the ice maker forward, and remove it.

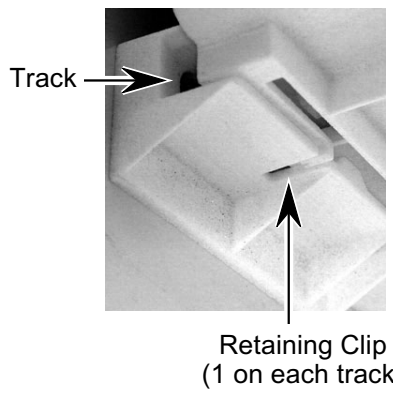

g) **If you are completely removing the ice maker,** unplug the wiring harness connector from the ice maker.

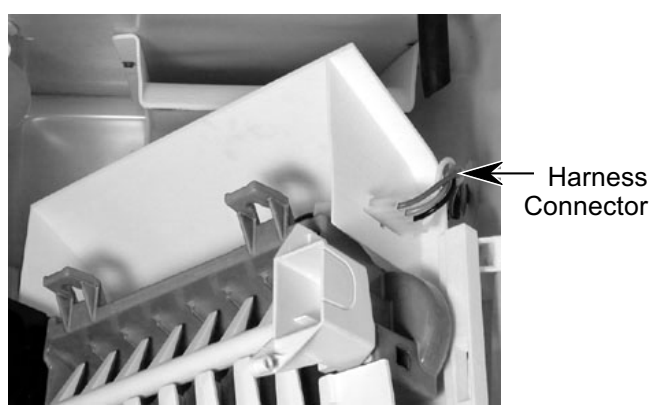

h) **If you do not want to completely remove the ice maker** rotate the ice maker so the square end with the motor faces the front, and hang the flange of the ice maker on the track that is attached to the freezer mullion.

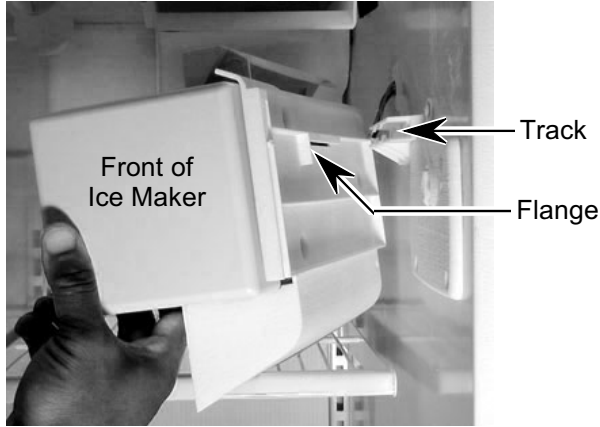

b) Slowly pull the end of the water fill nozzle out of the fitting in the top of the freezer liner, then continue to pull the rest of the tube out of the liner. It will require some force to remove the first foot or so of tube from the liner. **NOTE:** If the fill tube has water frozen inside, it will be necessary to melt the ice before removing the tubing, otherwise the tubing will tear when it is removed. Follow step 4 to melt the ice. If the fill tube is free of ice, skip step 4.

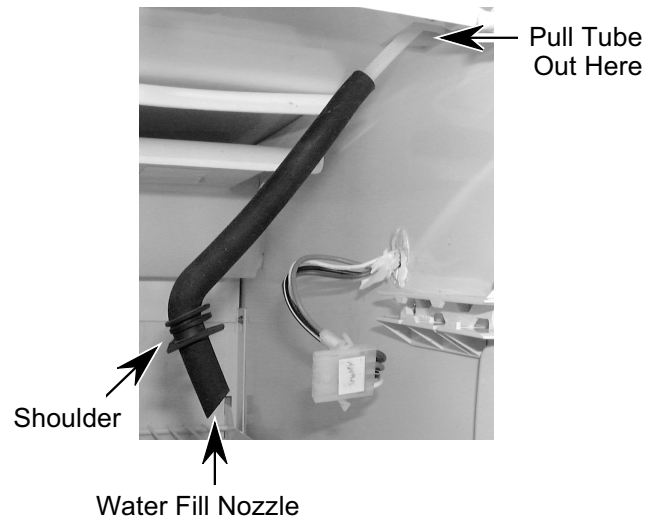

3. To remove the water fill tube:

a) From the rear of the unit, disconnect the upper water line from the fitting. To remove the tube, press down on the locking ring at the top until the tube is released.

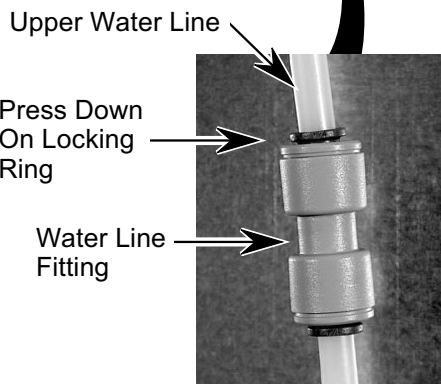
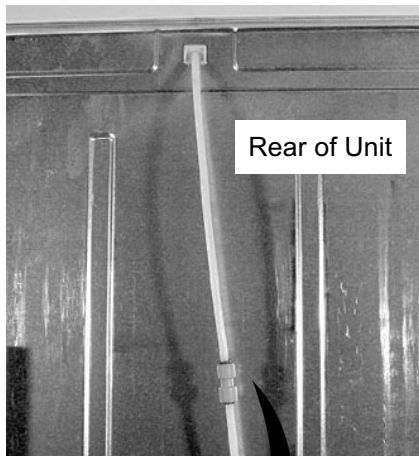

4. To melt ice inside the water fill tube:

a) Fill a plastic squeeze bottle with hot water.
 b) Place a container below the water fill nozzle.

Continued on the next page.

- c) Install a length of flexible tubing on the spout of the squeeze bottle.
- d) Insert the end of the flexible tubing into the water fill nozzle as far as ice blockage.
- e) Squeeze the bottle and allow the hot water to melt all of the ice.

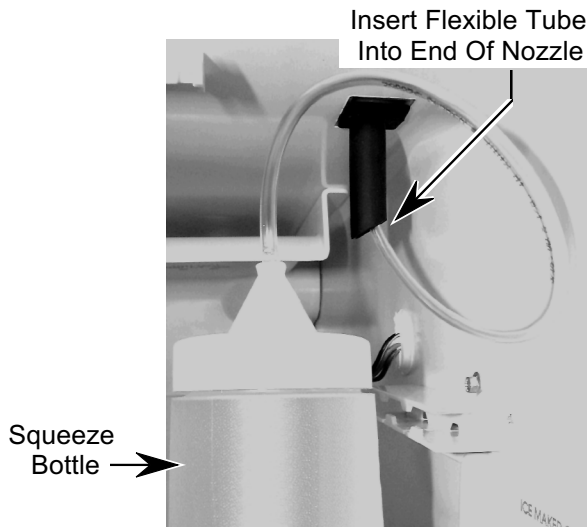

- b) Position the water fill nozzle so that the bend is toward the mullion, and insert the inner half of the grooved shoulder into the square cutout of the liner.

Grooved Shoulder In Liner Cutout

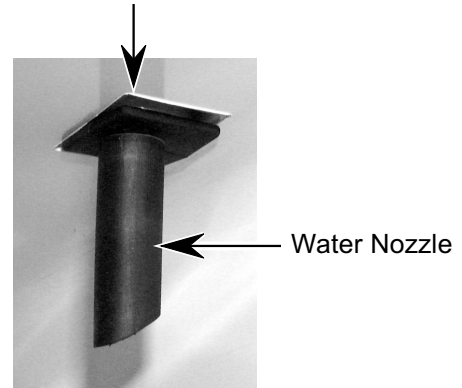

- c) Push the end of the tube into the water line fitting as far as it will go, and then pull on the tube to make sure that it is secure.

Push Tube Into Fitting

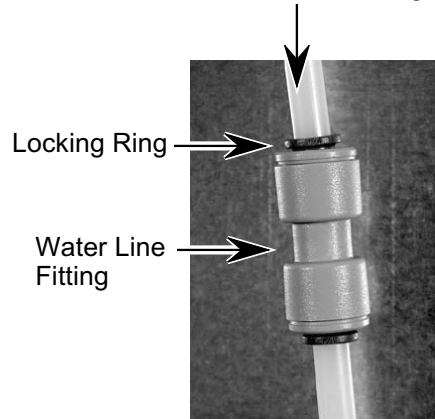

Rear of Unit

5. To reinstall the new tube:

- a) Insert the end of the tube into the hole of the freezer liner fitting, and push it through as far as the nozzle will allow. To prevent a water flow restriction, do not twist the tube and nozzle assembly. Pull the end of the tube at the rear of the unit to take up any slack. **NOTE:** The end of the tube may get caught on the fitting at the back of the unit. If this happens, position the tube in the center of the hole with a small screwdriver, and push the tube the rest of the way through from the front.

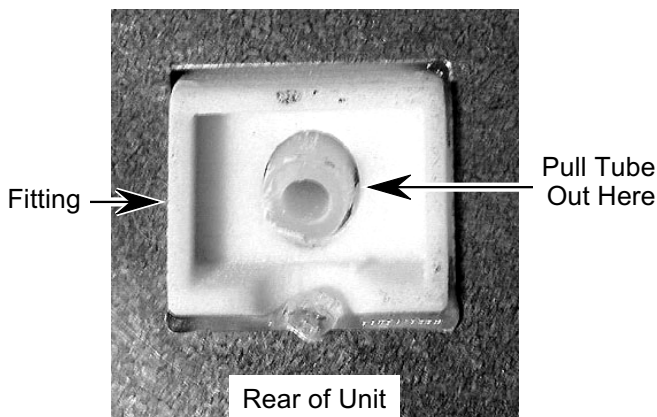

REMOVING THE EMITTER & RECEIVER MODULES

⚠ WARNING



Electrical Shock Hazard
Disconnect power before servicing.
Replace all panels before operating.
Failure to do so can result in death or electrical shock.

1. Disconnect the unit from the electrical supply.

NOTE: If either the emitter or receiver board fails, both of the boards will have to be replaced. The part numbers for the emitter and receiver boards will be substituted with a single kit number, which includes both boards.

2. To remove the emitter module:

- a) Open the freezer door.
- b) Remove the three screws from the module.

Screw (1 of 3)

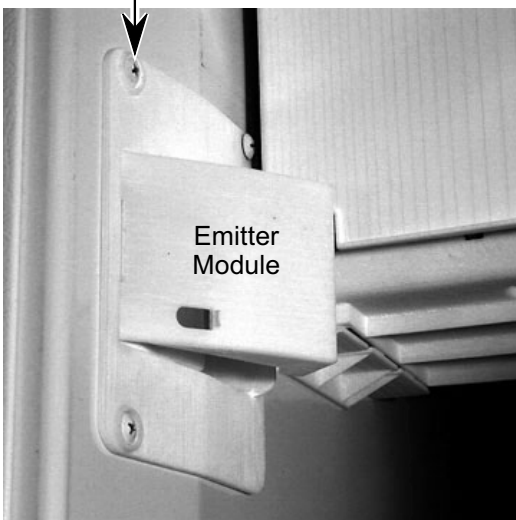

- c) Pull the module out and remove the connector from the board.

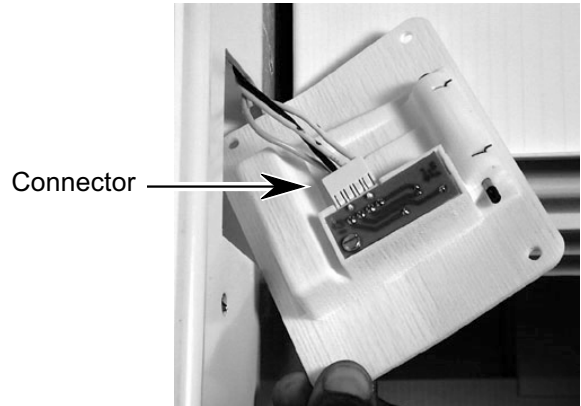

3. To remove the receiver module:

- a) Open the freezer door.
- b) Remove the three screws from the module.

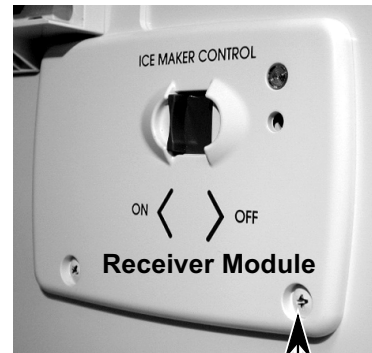

Screw (1 of 3)

- c) Pull the module out and remove the connector from the board.

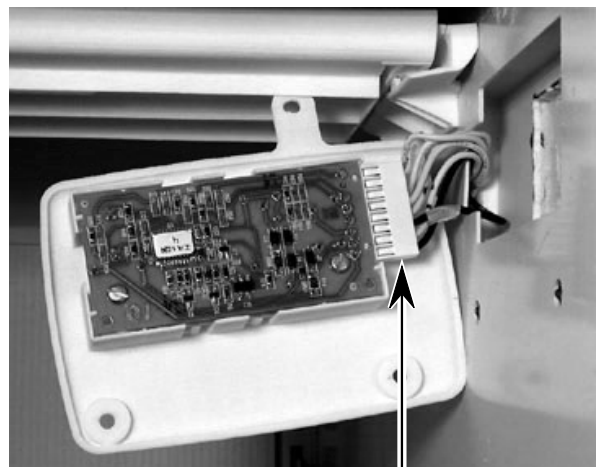

REMOVING & REINSTALLING THE MOTOR

⚠ WARNING



Electrical Shock Hazard

Disconnect power before servicing.
Replace all panels before operating.
Failure to do so can result in death or electrical shock.

1. Disconnect the unit from the electrical supply.
2. **To remove the motor:**
 - a) Open the freezer door.
 - b) Remove the ice container from the freezer door.

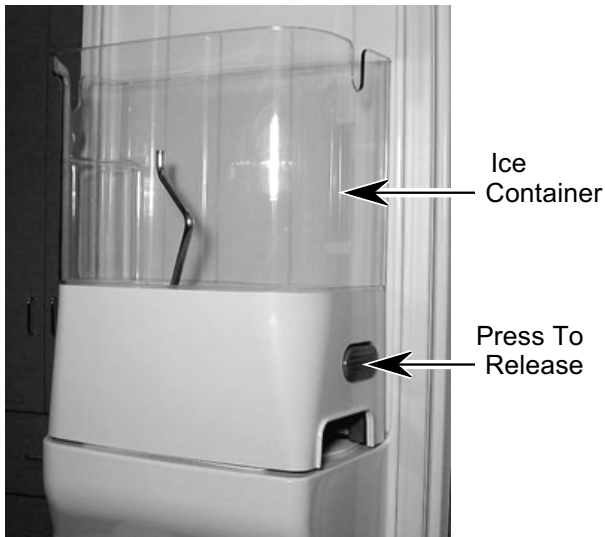

- c) Remove the two screws from the motor housing cover and remove the cover.



- d) Disconnect the harness connector from the motor terminals.

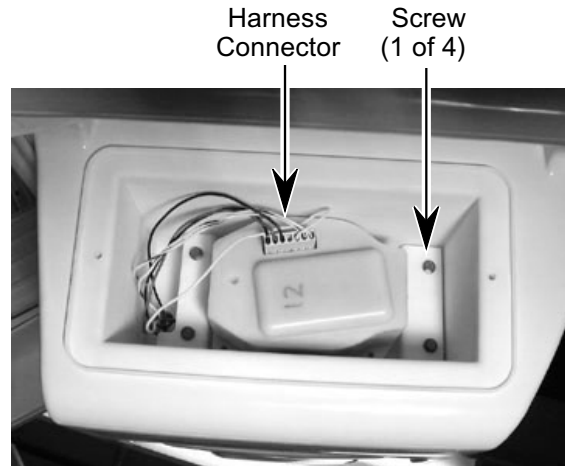

- e) Remove the four screws from the motor bracket and allow the motor to drop down.

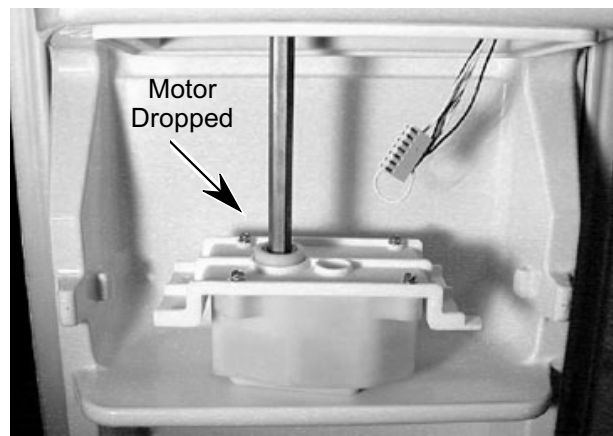

- f) Pull the hex drive shaft out of the motor.

Pull Drive Shaft From Motor

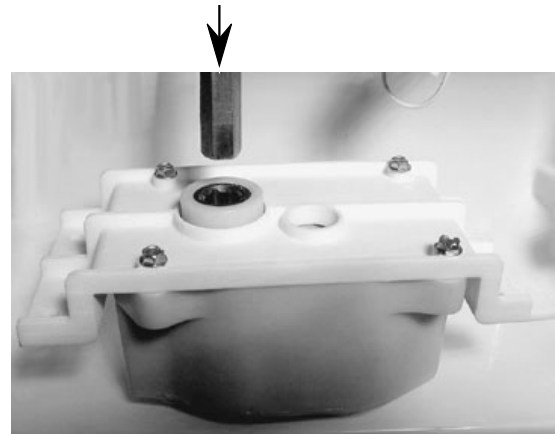

3. **To reinstall the motor:**

- a) Remove the two screws from the hex drive shaft coupling holder and remove the coupling assembly.

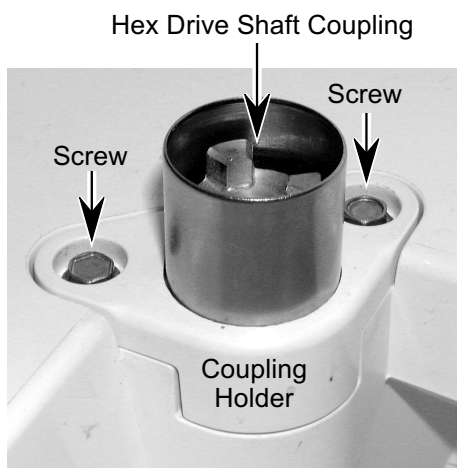

- b) Install the hex drive shaft in the motor as far as it will go.
c) Slide the new motor assembly back into place in the freezer door and mount it with the four screws you removed earlier. Make sure that the top of the hex drive shaft, spring, and pin are through the hole in the ice container plate. NOTE: On 2002, and later models, the pin is not used.

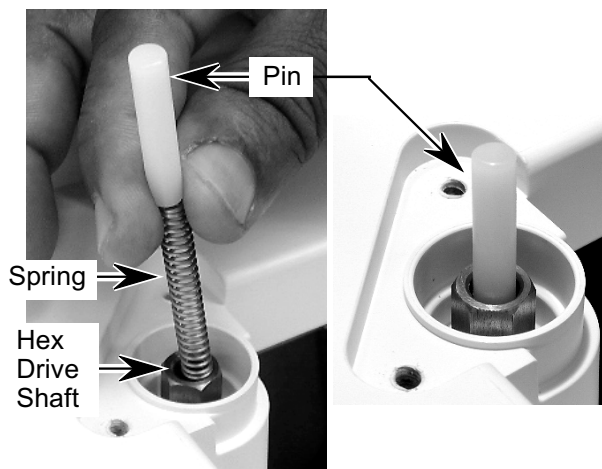

- d) Plug the harness connector into the motor. NOTE: The connector is designed to fit only one way on the motor terminals.
e) Position the motor housing cover so that the raised center faces the motor, and mount it in place with the two screws you removed earlier.
f) Make sure that the spring and pin are in the center hole of the hex drive shaft, and that the bearing and seal are properly positioned on the coupling, as shown.

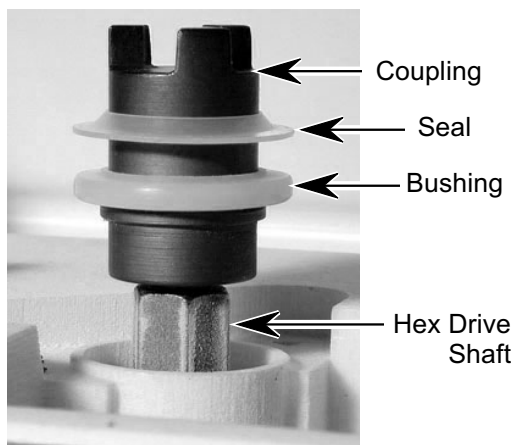

- g) Position the coupling assembly over the spring-loaded pin, then push down on the coupling and align it with the top of the hex drive shaft. Secure the coupling assembly with the two screws you removed earlier.

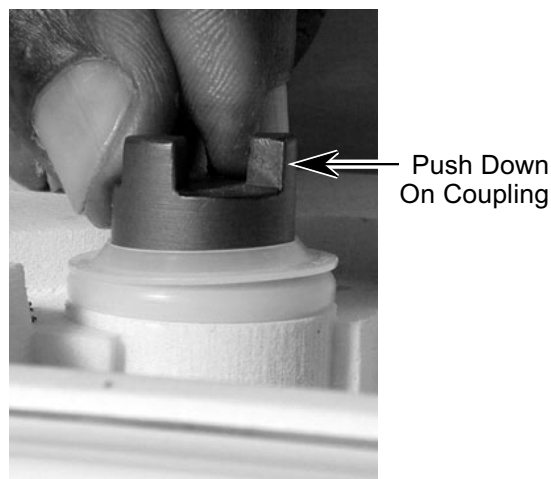

Continued on the next page.

h) Replace the ice container on the freezer door plate. NOTE: The coupling in the ice container does not have to align with the coupling on the end of the hex drive shaft when the ice container is installed. They will engage as soon as the ice dis-

penser is activated. At that time, the motor will turn, and the spring-loaded coupling on the end of the hex drive shaft will pop up and engage the ice container coupling (you will hear a “snap” when the coupling pops up and engages).

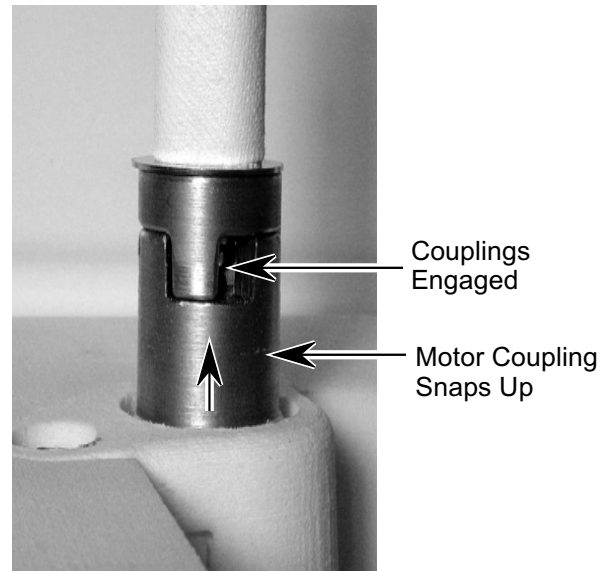
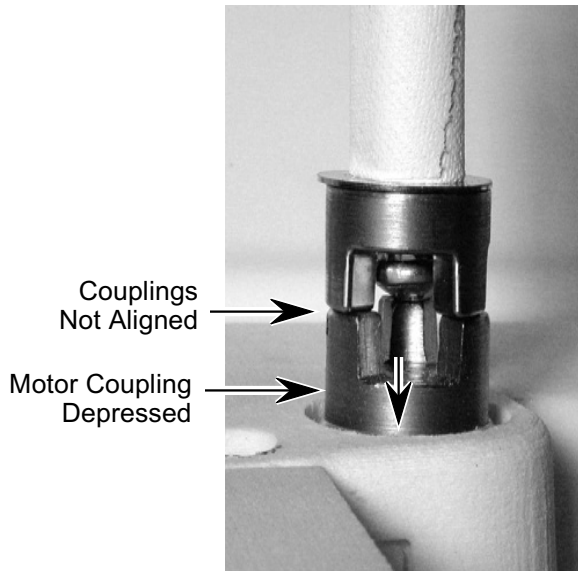

ACCESSING THE SELECTOR SWITCH PACK & DISPENSER SWITCHES

⚠ WARNING



Electrical Shock Hazard
Disconnect power before servicing.
Replace all panels before operating.
Failure to do so can result in death or electrical shock.

1. Disconnect the unit from the electrical supply.
2. Pull out and unclip the drip tray on the ice and water dispenser compartment.

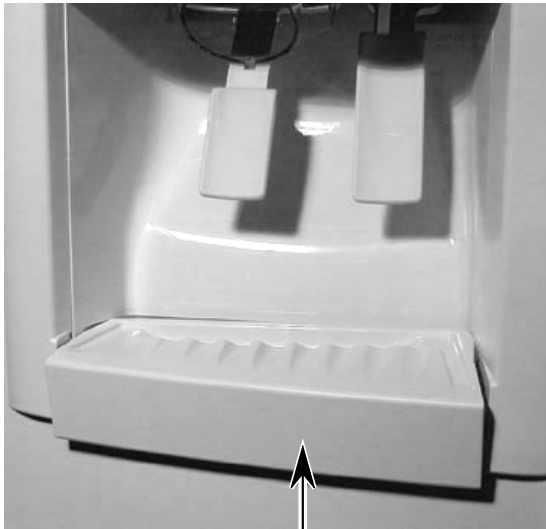

Drip Tray

3. Remove the screws from the ice and water dispenser compartment front panel and turn it over. The selector switch pack and dispenser switches are now accessible for testing.

Ice Dispenser Switch

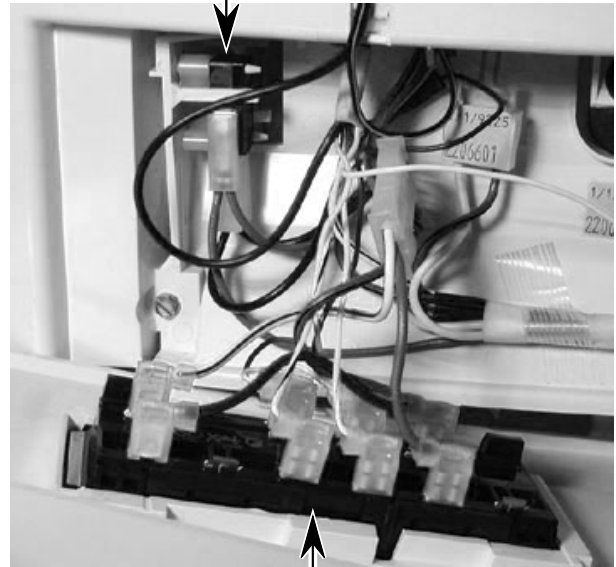

Selector Switch Pack

— NOTES —

DIAGNOSTICS & TROUBLESHOOTING

DIAGNOSTICS

OPTICS DIAGNOSTICS MODE

Diagnostics are used to determine whether the optics circuits are operating properly. If the optics circuits are malfunctioning, the ice maker will not operate.

The optics system consists of an emitter board and a receiver board. The emitter board transmits a beam of infrared light that is detected by the receiver. If the beam of light is interrupted, the ice maker will not operate.

The optics system can have one of two types of optics board designs installed: the original design, or the 2002 design.

Use the following flow chart to determine which of the board designs are installed. Once this is determined, you will be directed to perform the appropriate optics diagnostics procedure.

FLOW CHART TO DETERMINE OPTICS BOARD DESIGN

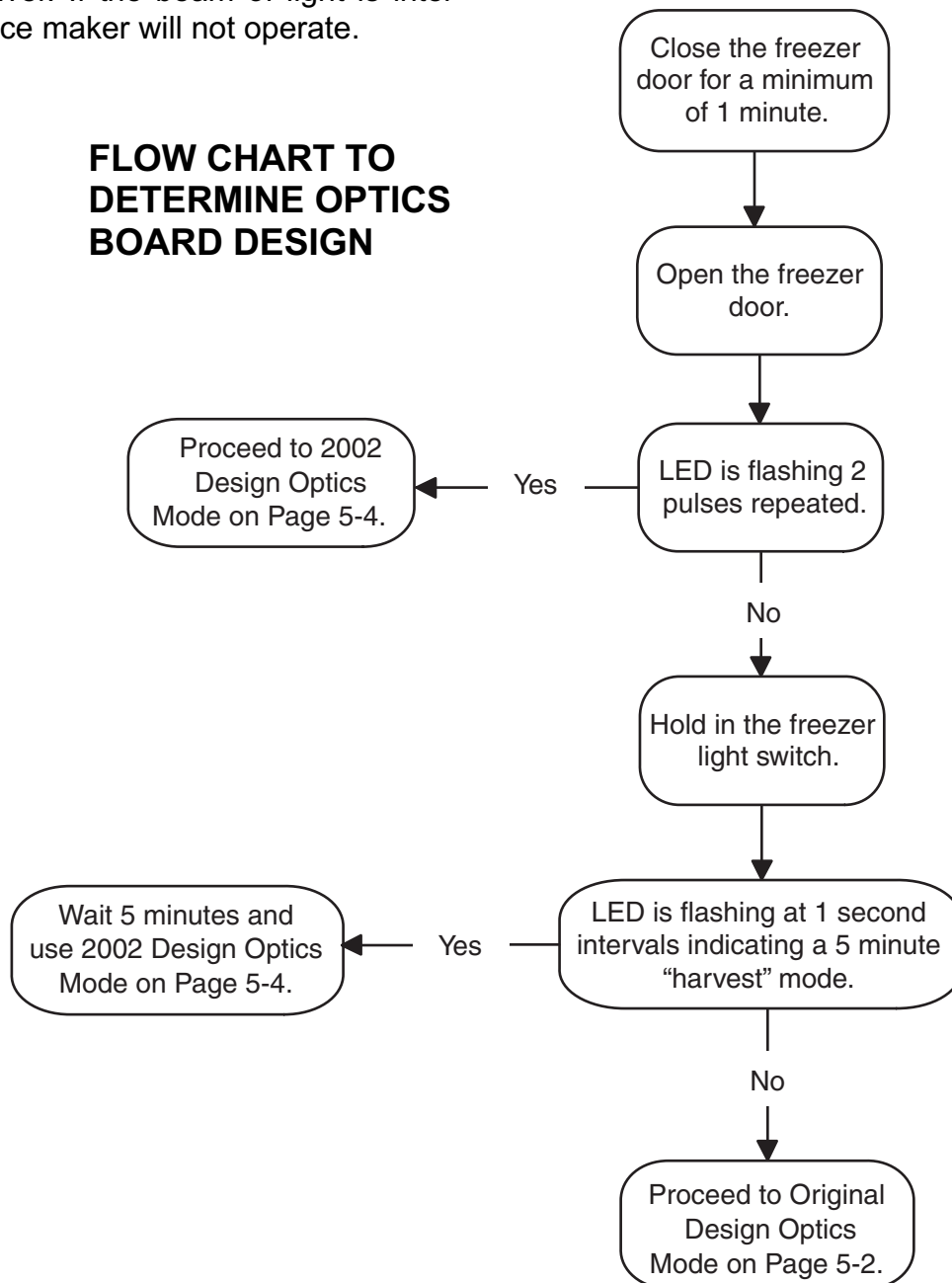

**OPTICS DIAGNOSTICS FOR ORIGINAL DESIGN BOARDS
KIT #4388635 SUBS TO #4389102
EMITTER—PART #2198585
RECEIVER—PART #2198586**

To initiate an optics check, perform the following steps:

1. Open the freezer door.
2. Remove enough ice from the ice bin so that the ice level is at least one inch below the U-shaped cutouts in the bin.

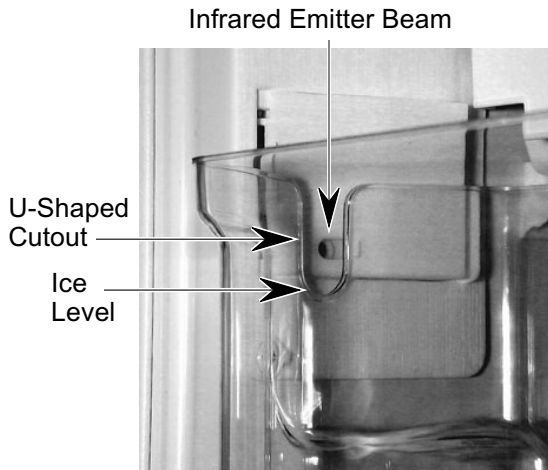

3. Make sure the ice maker manual shutoff slide is in the "ON" (open) position on the infrared receiver module.

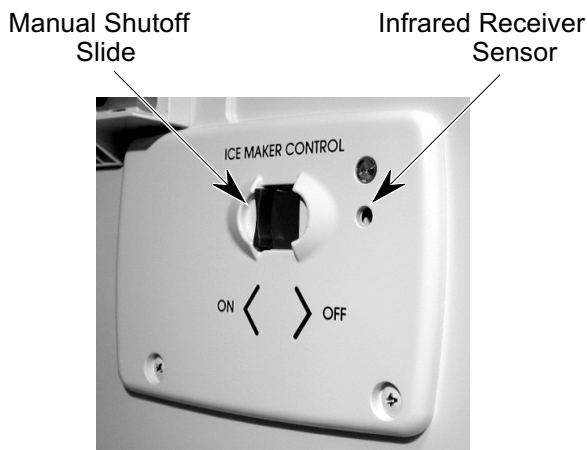

4. Close the freezer door for a minimum of 10 seconds.

5. Open the freezer door and activate the freezer door switch 3 times. NOTE: This step must be completed within 10 seconds of opening the freezer door.

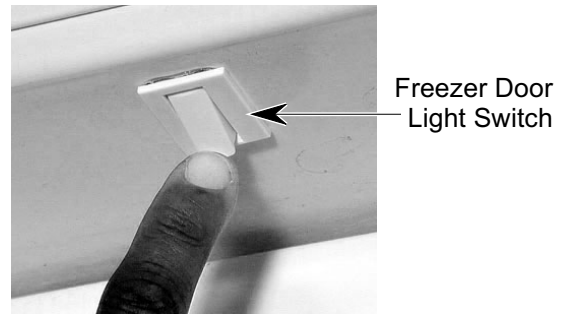

6. Close the freezer door within 20 seconds of completing step 5.
7. Wait for a minimum of 5 seconds, and a maximum of 50 seconds, then open the freezer door and view the status LED on the infrared receiver module for the error code. NOTE: You will have 60 seconds to open the freezer door, and 2 seconds from then to view the LED output code.

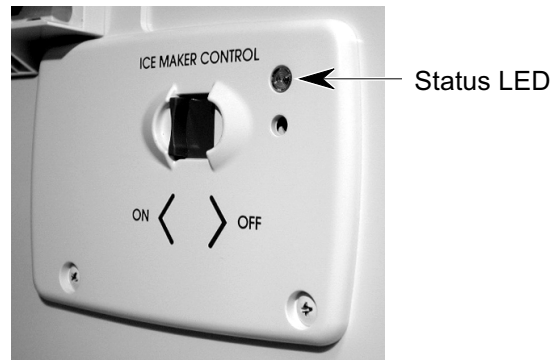

If you observe two LED pulses (flashes), perform the following steps.

1. Open the freezer door and remove the ice bin from the door.
2. Make sure the ice maker manual shutoff slide is in the "on" (open) position.
3. Tape the spring-loaded emitter door to the emitter cover in the "down" position.
4. Close the freezer door for at least 10 seconds.

5. Open the freezer door and actuate the freezer door switch 3 times. NOTE: This step must be completed within 10 seconds of opening the freezer door.
6. Close the freezer door within 20 seconds of completing step 5.
7. Wait for a minimum of 5 seconds, and a maximum of 50 seconds, then open the freezer door, and view the status LED on the infrared receiver module for the error code. NOTE: You will have 60 seconds to open the freezer door, and 2 seconds from then to view the LED output code.

If the LED still flashes twice, there could be dirt or frost on the optics, something could be blocking the infrared beam path, or the optics may be defective. Clean the optic elements and repeat the previous test.

If the LED does not flash, the ice maker may have been in a harvest, preventing the diagnostics from being performed. Look at the ice maker to make sure the ejector is at the home position. If it is, wait 3 minutes, and try running test again. If the LED still does not flash, the optics boards may be defective.

**OPTICS DIAGNOSTICS FOR
2002 DESIGN BOARDS
KIT #4389102
EMITTER—PART #2220398
RECEIVER—PART #2220402**

To initiate an optics check, perform the following steps:

1. Open the freezer door.
2. View the status LED. It should flash twice, pause for 1 second, and repeat the cycle for as long as the door is open.

NOTES:

- If the LED is not flashing, the ice maker may be in the 5 minute “harvest” mode. If so, push in on the freezer door switch with your finger, and observe the LED. It should begin to flash at 1 second intervals, and continue to flash for as long as you hold the door switch.
 - If the LED does not flash, as described above, the original style optics boards may be installed. Perform the steps, shown in Chart A, on page 5-6.
3. Check the ice maker manual shutoff slide and make sure that it is in the “ON” (open) position on the infrared receiver module.

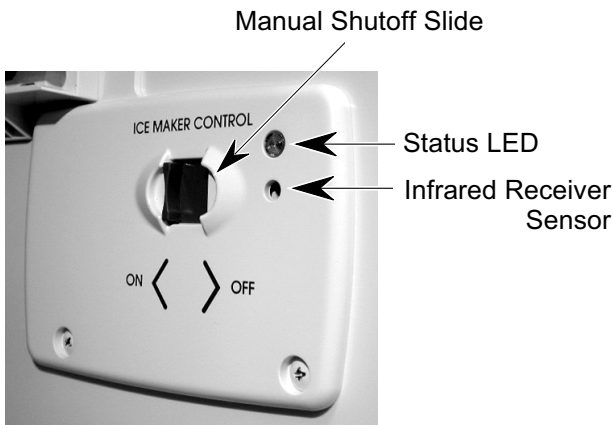

4. Close the flapper door on the emitter module so that the infrared beam has a clear path to the receiver board.

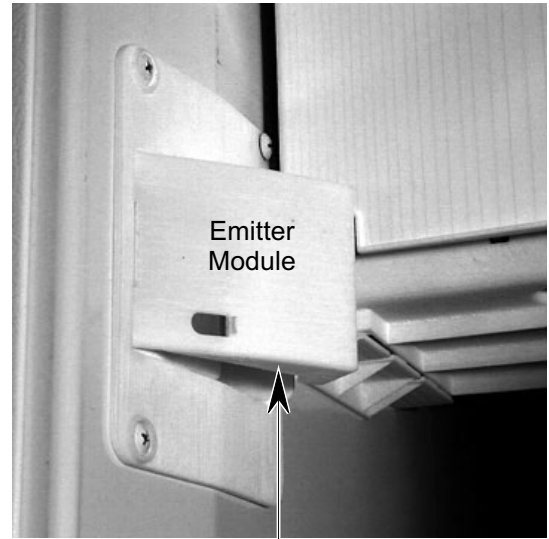

Door Shown In The Open Position

5. Make sure that the door switch is not pushed in, and view the status LED. With the flapper door on the emitter module held closed, and the ice maker not in the 5 minute “harvest” mode, the status LED should be on steady. This indicates that the optics circuits are operating properly. If the status LED continues to flash, refer to the “Troubleshooting Chart” on page 5-9.

COMPONENT DIAGNOSTICS MODE

⚠ WARNING



Electrical Shock Hazard
Voltage is present during these tests.

NOTE: The optics must be working properly to test the ice maker. If the optics test fails, you will not be able to force a harvest and check the ice maker. Refer to the Troubleshooting Chart on page 5-10 for additional servicing information.

IMPORTANT: If the freezer temperature is not cold enough to allow the ice maker bi-metal to close, a jumper must be installed on the ice maker at test points T and H, and the test rerun.

1. Run an optics check as described in the previous section.
2. Disconnect power to the unit.

3. Slide the ice maker out of the mounting rails and leave the wiring harness connected.
4. Jumper the thermostat, as shown below.
5. Connect power to the unit.
6. Remount the ice maker, making sure that the water fill tube is inside the fill cup.
7. Make sure there is a clear path across the bin for the infrared beam to travel to the receiver sensor.
8. Close the freezer door and wait 5 seconds to allow the optics relay to close.
9. Open the freezer door and you will see the ejector bar moving. Remove the thermostat jumper prior to the ejector blades reaching the 10:00 position, or else you will not see the water fill. The mold should be warm due to the heater operation.
10. Disconnect the power immediately after the water fill.
11. With the freezer door closed, reconnect the power.
12. Wait for a minimum of 5 seconds, and a maximum of 50 seconds, then open the freezer door, and view the status LED for the output codes, as shown in Chart C, on page 5-7.

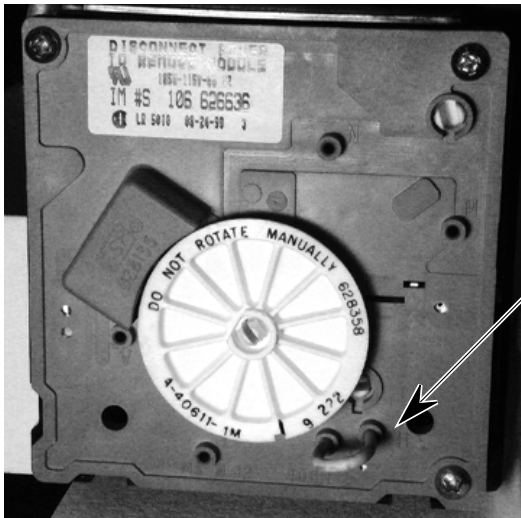

Motor Jumper (Points T and H)

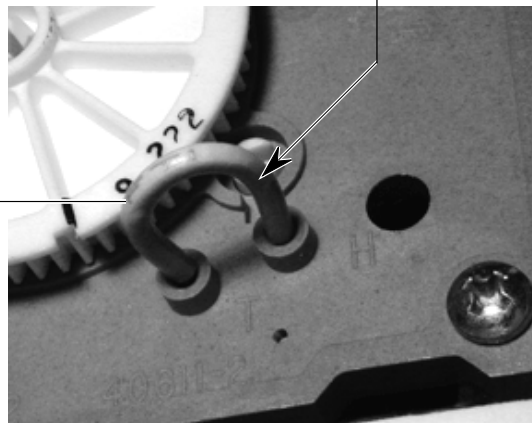

OPTICS DIAGNOSTICS MODE CHARTS

NOTES:

1. Optics Diagnostics will not respond:
 - For 5 minutes after the ice maker begins a “harvest” cycle. To reset the control, wait until the ice maker “parks,” then unplug the refrigerator for 5 seconds, and repeat the test.
 - While the control board is running self-checks. Reset the control, as above.
2. The ice maker control must be in the “ON” position.
3. The ice bin must be on the door and the ice level below the notched openings.

— Chart A —

Diagnostics Chart For Original Design Optics Boards

OPTICS DIAGNOSTICS PROCEDURE FOR ORIGINAL DESIGN BOARDS			
STEP #	STATUS LED	POSSIBLE CAUSES	ACTION
1. Open the freezer door (make sure that the freezer door has been closed for a minimum of 10 seconds prior to opening the door).	2 pulses , repeated once, indicates the optics are blocked, or defective. Clear the optics path, and repeat the “Optics Diagnostics Procedure.” Replace both boards, if necessary.	A steady light that is ON for 5 seconds indicates that both of the optics boards are good. Continue with the “Component Diagnostics Mode.”	If there is no light , unplug the refrigerator for 5 seconds, and repeat the test. If there is still no light, replace both optics boards.
2. Activate the door switch 3 times. Push the button in completely for 1 second each time.			
3. Close the freezer door for a minimum of 5 seconds for a maximum of 50 seconds.			
4. Open the freezer door and immediately view the diagnostics “status” LED.			

— Chart B —

Diagnostics Chart For 2002 Design Optics Boards

OPTICS DIAGNOSTICS PROCEDURE FOR 2002 DESIGN BOARDS			
STEP #	STATUS LED	POSSIBLE CAUSES	ACTION
1. Open the freezer door.	Two (2) pulses followed by a one (1) second delay (repeated).	The flapper door on the emitter is blocking the beam.	Go to Step 2.
		The optics are faulty.	Go to Step 2.
	No lamp.	Ice maker is in the “harvest” mode. The harvest mode consists of a five (5) minute period that starts when the bimetal closes, and the ice maker begins to run.	To confirm, press in and hold the freezer door switch. If in the “harvest” mode, the Status LED will flash once every second.
		Faulty Status LED, or original style boards are installed.	Replace the receiver and emitter boards, or perform the steps in Chart A.
2. Press in the emitter flapper door to unblock the optics beam.	Two (2) pulses followed by a one (1) second delay (repeated).	The Optics are faulty.	Replace the emitter and receiver boards.
	LED is on steadily.	The Optics are working properly.	Close the freezer door.

COMPONENT DIAGNOSTICS MODE CHART

— Chart C — Component Diagnostics Mode For Original & 2002 Design Boards

COMPONENT DIAGNOSTICS MODE (RUN OPTICS DIAGNOSTICS PROCEDURE FIRST)
1. Disconnect the power supply.
2. Slide the ice maker out and remove the cover.
3. Jumper holes "T" and "H" to bypass the bimetal and start a harvest.
4. Reconnect the power supply.
5. Close the freezer door to align the optics and a harvest cycle will begin in 5 seconds.
6. Open the freezer door and observe the ice maker. A "harvest" should be in progress.
NOTE: If holes "T" and "H" are properly jumpered and the ice maker will not run, stop the test, and check the ice maker.
7. Remove the jumper before the fingers reach 10:00. Reinstall the ice maker, or be prepared to catch the water fill during step 8.
8. Disconnect power immediately after the water fill.
9. With the freezer door closed, reconnect the power supply.
10. Wait 5 seconds, to a maximum of 50 seconds, then open the freezer door, and watch the Status LED for one of the following codes.
Status LED Output Codes
4 PULSES , repeated once, indicates the relay is defective. Replace both the emitter and receiver boards.
3 PULSES , repeated once, indicates the optics and relay are okay, but the ice maker is not being sensed, or will not operate. If this happens:
<ul style="list-style-type: none"> • Check the bail arm switch to make sure it is On. • Check the ice maker circuit and the connections back to the receiver board and neutral. • Check the ice maker components.
2 PULSES , repeated once, indicates the optics are blocked, or defective. Clear the optics path, and repeat the "Optics Diagnostics Procedure." Replace both boards, if necessary.
STEADY LIGHT for 5 seconds indicates the relay and optics are okay, and the receiver senses the ice maker.
NO LIGHT : Unplug the refrigerator for 5 seconds, and repeat the test.

TROUBLESHOOTING CHART A

Original Optics Design

TEST	RESULT	POSSIBLE CAUSE	CORRECTIVE ACTION
Optics Diagnostic Mode (optics test only)	2 LED pulses, repeated.	Ice maker slide control turned OFF (closed).	Move ice maker slide control to ON (open).
		Dirt on optics.	Clean dirt from optics.
		Misaligned ice bin.	Realign ice bin cutouts with optics path.
		Ice in bin blocking optics path.	Remove enough ice from bin to clear path.
		Frost on optics lenses.	Clean frost from lenses.
		Ice bin not closing optics emitter door properly.	Tape emitter door closed and retest. If optics tests okay, the ice bin and/or its mounting are at fault.
		Freezer door not completely closed during Optics Test.	Close freezer door and retest.
		Failed optics.	Replace emitter and receiver boards and retest.
		Ice maker is in "harvest" cycle.	Wait 5 minutes until "harvest" cycle is complete and retest.
		LED was not viewed within 2 seconds of opening freezer door.	Retest and view LED within 2 seconds of opening freezer door.
No LED pulses.	Freezer door was not closed for a minimum of 5 seconds before starting test.	Close freezer door, wait for at least 5 seconds, and retest.	
	Incorrect wiring at emitter or receiver board.	Correct wiring and retest.	
	Optics performing self-tests (will not perform diagnostic tests during this time).	Make sure ice maker is "parked." Unplug refrigerator for 5 seconds to reset optics control and retest.	
	LED is defective.	Replace emitter and receiver boards and retest.	
	Ice maker control circuit is functioning normally.	None required.	
5 second LED on steady.	5 second LED on steady.		

TROUBLESHOOTING CHART B

2002 Optics Design

TEST	RESULT	POSSIBLE CAUSE	CORRECTIVE ACTION
Optics Diagnostic Mode (optics test only)	2 LED pulses, repeated.	Ice maker slide control turned OFF (closed).	Move ice maker slide control to ON (open).
		Dirt on optics.	Clean dirt from optics.
		Frost on optics lenses.	Clean frost from lenses.
		Flapper door is open and is blocking the emitter beam.	Hold the emitter door closed, and the status LED should be on steady.
		Failed optics.	Replace emitter and receiver boards and retest.
	No LED pulses.	Ice maker is in 5 minute "harvest" cycle.	To verify, press in on door switch. Status LED should flash at 1 second intervals.
		Incorrect wiring at emitter or receiver board.	Correct wiring and retest.
		Optics performing self-tests (will not perform diagnostic tests during this time).	Make sure ice maker is "parked." Unplug refrigerator for 5 seconds to reset optics control and retest.
		LED is defective.	Replace emitter and receiver boards and retest.
		Flapper door is held closed.	Normal with flapper door closed.
5 second LED on steady.			

TROUBLESHOOTING CHART C

Component Diagnostics Mode

TEST	RESULT	POSSIBLE CAUSE	CORRECTIVE ACTION
Ice Maker Control Circuit	4 LED pulses, repeated once.	Defective emitter relay.	Replace emitter and receiver boards and retest.
	3 LED pulses, repeated.	Ice maker in "home" position and bimetal is open.	Install jumper in ice maker holes "T" and "H" and retest.
		Ice maker bail arm switch in OFF position.	Bail arm not used in these models but switch must be ON.
		Ice maker is unplugged.	Plug in ice maker and retest.
		Thermal fuse in ice maker harness is open.	Replace ice maker harness and retest.
	2 LED pulses.	Incorrect wiring at emitter or receiver board.	Correct wiring and retest.
		Problem with ice maker.	See "Ice Maker Checks."
		Optics boards defective.	Replace emitter and receiver boards and retest.
		Ice maker control circuit is functioning normally.	None required.
		Optics performing self-tests (will not perform diagnostic tests during this time).	Make sure ice maker is "parked." Unplug refrigerator for 5 seconds to reset optics control and retest.
No LED pulses.		Optics check not run before testing ice maker.	Run optics test and recheck ice maker.
Ice Maker Checks	Ejector bar does not stop at "home" position.	Freezer door not closed after Optics test.	Close freezer door to start harvest.
		Optics path not clear.	Clear optics path.
		Optics test failure.	Replace emitter and receiver boards and retest.
		Ice maker is unplugged.	Plug ice maker in.
		Thermal fuse in ice maker harness is open.	Replace ice maker harness.
		Wiring harness or door switch problem.	Check continuity in wiring harness and door switch.
		Motor has failed.	Replace ice maker module.
		Thermostat jumper not making contact.	Reposition jumper.
		Heater has failed.	Replace ice maker.
		No water fill.	Thermostat jumper was left installed past 11:00 position.
Water valve is unplugged.	Connect harness to valve.		
Customer's water supply is problem.	Check for proper water supply.		
Frozen water fill tube.	Defrost the water fill tube and check for seeping valve.		
Water valve has failed.	Replace water valve.		
Ejector bar does not stop at "home" position.	Thermostat jumper not removed.	Remove thermostat jumper.	

TROUBLESHOOTING THE MOTOR

⚠️ WARNING



Electrical Shock Hazard
Disconnect power before servicing.
Replace all panels before operating.
Failure to do so can result in death or electrical shock.

NOTE: Refer to the “Motor Failure Modes Chart” at the bottom of the page.

1. Motor does not hum or rotate.
 - a) 1, 2, 3, 5, 6.
 - b) Make sure refrigerator is plugged in.
 - c) Make sure freezer door is completely closed.
 - d) Make sure selection button is in UNLOCK position.
 - e) Wait 1 minute after an ice jam occurs for motor’s surge protector to automatically reset.
2. Motor hums but does not rotate.
 - a) Clear ice jam in ice bin.
 - b) Possible broken gear inside motor assembly.
3. Motor starts but heats rapidly.
 - a) 2, 3, 5.
4. Motor runs too hot after extended operation.
 - a) 3, 4, 6, 9.
5. Reduction in power—motor overheats.
 - a) 2, 5, 6.
6. High no-load speed (30 RPM is nominal).
 - a) 2
7. Excessive noise (mechanical).
 - a) 2, 7, 8.
8. Jerky operation—severe vibration.
 - a) 2.
- f) Disconnect/reconnect the 6-pin harness to the motor 3 - 5 times to remove any oxidation buildup on the connector pins.
- g) Check power in the circuit (see “Checking The Switch Pack on page 5-14”).

Motor Failure Modes Chart

1. Open circuit in connection to line (e. g. house fuse is blown or motor is defective).
2. Defective motor.
3. Overloaded motor (mechanical failure in load).
4. Ventilation blocked.
5. Wrong connection to motor.
6. Improper or low line voltage.
7. Poor alignment between motor and load (e. g. loose motor mounting).
8. Amplified motor noise due to mounting conditions.
9. High ambient temperature.

⚠ WARNING



Electrical Shock Hazard
Voltage is present during these tests.

CHECKING THE MOTOR

To check voltages* at the motor for crushed or cubed ice operation:

1. Open the freezer door and remove the ice bucket from the door.
2. Tape the door switch closed.



Door Switch
Taped Closed

* Voltage readings may vary, depending on the supply voltage, and the type of test equipment being used.

NOTE: When you are instructed to make a reading at the motor connector, press the tips of the red and black test leads into the indicated harness connector slots so they touch the bare metal wire connectors. Reach around the front of the door and press the ice dispenser lever to activate the dispenser switch.

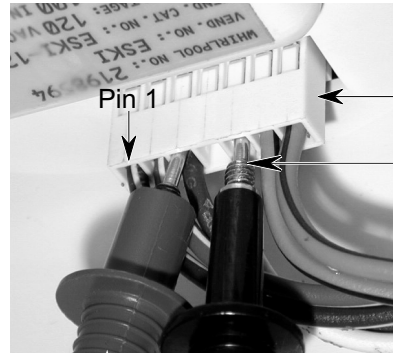

Motor Harness
Connector

Press Tips Into
Connector Slots
Against Bare Wire
Terminals To Check
Voltages

Test Leads

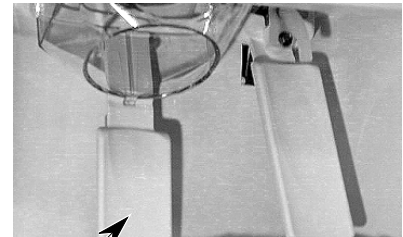

Press The Ice
Dispenser Lever

3. Press the **Unlocked** button on the ice and water dispenser front panel.
4. Touch the AC meter test leads to wire harness pins 3 and 5, then press the ice dispenser lever. The meter should read 115 VAC.
5. Touch the DC meter's black test lead to wire harness pin 6, and the red test lead to pin 7, then press the ice dispenser lever. The meter should read +115 VDC \pm 10%.
6. Press the **Crushed** ice button on the ice and water dispenser front panel.
7. Touch the DC meter's black test lead to wire harness pin 1, and the red test lead to pin 2, then press the ice dispenser lever. The meter should read +115 VDC \pm 10%.
8. Press the **Cube** ice button on the ice and water dispenser front panel.
9. Touch the DC meter's red test lead to wire harness pin 1, and the black test lead to pin 2, then press the ice dispenser lever. The meter should read +115 VDC \pm 10%.
10. Remove the tape from the door switch.

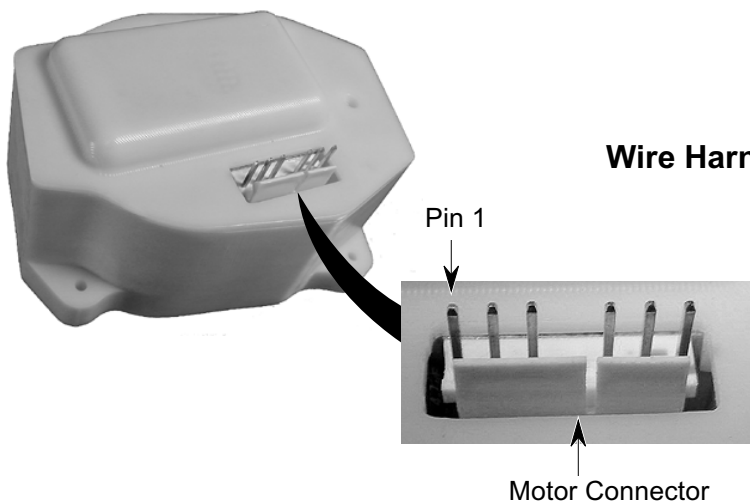

Wire Harness Pinouts

+115 VDC	7 ○	To Switch Pack (OR/BU)
-115 VDC	6 ○	To Switch Pack (PK/BK)
Neutral	5 ○	(WH)
	4 ○	No Connection
L1 (115 VAC)	3 ○	(BU)
Motor (115 VDC)	2 ○	From Switch Pack (RD/WH)
Motor (115 VDC)	1 ○	From Switch Pack (BR/WH)

⚠ WARNING

Electrical Shock Hazard
Voltage is present during these tests.

CHECKING THE SWITCH PACK

To check voltages at the switch pack:

NOTE: All of the wires must be connected to the pins on the switch pack to obtain the following readings, including the wire to the pin being measured. Also, the freezer door light switch must be in the closed (taped down) position before performing any voltage checks. When measuring a voltage, lift the wire connector partially off the switch terminal, and touch the meter test lead probe to the terminal (see below).

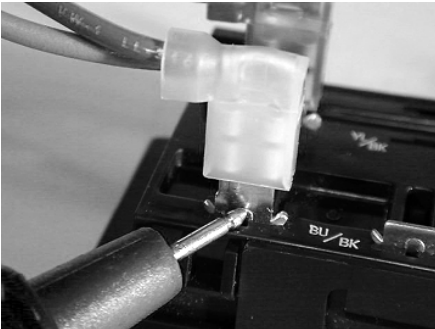

1. To check the **Light On** and **Light Off** switches, press the **Light** button on the ice and water dispenser front panel, and the dispenser housing light should turn on. If the light does not turn on:
 - a) Check switch pack pins BU/BK and YL/BK using an AC voltmeter. The meter should read 115 VAC if the switch is open, or 0 VAC if the switch is closed.
 - b) Disconnect the BU/BK and YL/BK wires from the **Light** switch terminals. Check the switch continuity with an ohmmeter. The continuity should change when the **Light** switch is pressed on and off.

2. The **Locked/Unlocked** switch allows AC voltage to be sent to the motor through the ice dispenser lever switch when it is in the **Unlocked** position. If the **Unlocked** switch is defective, the dispenser lever will not operate the motor. To check the switch:
 - a) Check pins BU/BK and GY using an AC voltmeter. The meter should read 115 VAC if the switch is open, (**Locked**), or 0 VAC if the switch is closed (**Unlocked**).
 - b) Disconnect the BU/BK and GY wires from the **Lock/Unlocked** switch terminals. Check the switch continuity with an ohmmeter. The continuity should change when the switch is changed from **Locked** to **Unlocked**.

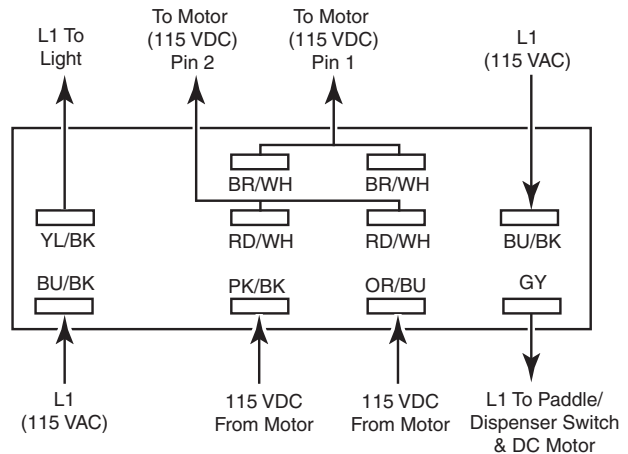

Switch Pack Pinouts

3. To check to make sure that DC voltage is being supplied to the switch pack:
 - a) Press the **Unlocked** button.
 - b) Touch the DC voltmeter's black test lead to PK/BK and the red test lead to OR/BU, then press the ice dispenser lever. The meter should read +115 VDC $\pm 10\%$.
4. To check the **Crushed** and **Cube** ice switches:
 - a) Press the **Unlocked** and the **Crushed** buttons on the ice and water dispenser front panel.
 - b) Touch the DC voltmeter's black test lead to BR/WH and the red test lead to RD/WH, then press the ice dispenser lever. The meter should read +115 VDC $\pm 10\%$.
 - c) Press the **Unlocked** and the **Cube** buttons on the ice and water dispenser front panel.

- d) Touch the DC voltmeter's black test lead to RD/WH and the red test lead to BR/WH, then press the ice dispenser lever. The meter should read +115 VDC $\pm 10\%$.

⚠ WARNING



Electrical Shock Hazard

Disconnect power before servicing.

Replace all panels before operating.

Failure to do so can result in death or electrical shock.

Continuity Tests

Refer to the chart below to perform the ice dispenser switch pack continuity tests. All of the tests are performed with power disconnected from the unit, and the wires disconnected from the terminals of the switch under test.

Switch Pack Setup	Continuity Readings
Light Interlock Switch With Switch Closed	Terminal BK to BU/BK
Ice Dispenser "Unlock" Selected	Terminal BU/BK to GY
Ice Lever Switch With Dispenser Pushed In	Terminal GY to BU
Dispenser Light Switch With Light On Selected	Terminal BU/BK to YL/BK
Crushed Ice Selected	Terminals OR/BU to RD/WH & PK/BK to BR/WH
Cubed Ice Selected	Terminals OR/BU to BR/WH & PK/BK to RD/WH

⚠ WARNING



Electrical Shock Hazard

**Disconnect power before servicing.
Replace all panels before operating.
Failure to do so can result in death or
electrical shock.**

SERVICING THE HARNESS & MOTOR CONNECTOR

Both the motor connector and the wire harness are serviceable. To remove a wire from the motor connector:

1. Use a small screwdriver or knife and lift the wire retainer tab far enough to slide the wire terminal out of the connector.

2. To install a wire terminal, position the terminal with the slot facing the retainer tab, and slide it into the connector. Press down on the retainer tab to lock it in place.

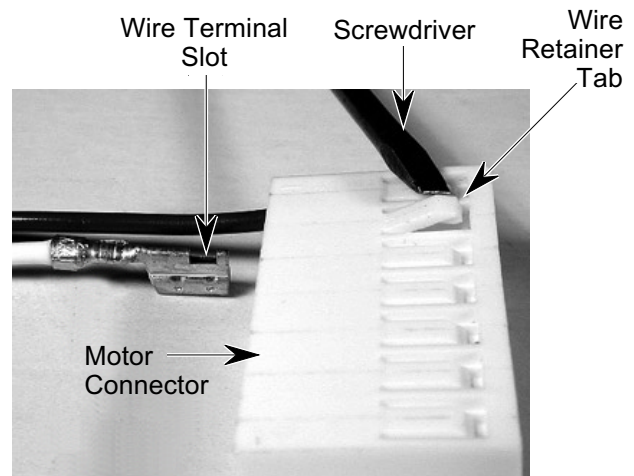

WIRING DIAGRAMS & STRIP CIRCUITS

WHIRLPOOL WIRING DIAGRAM

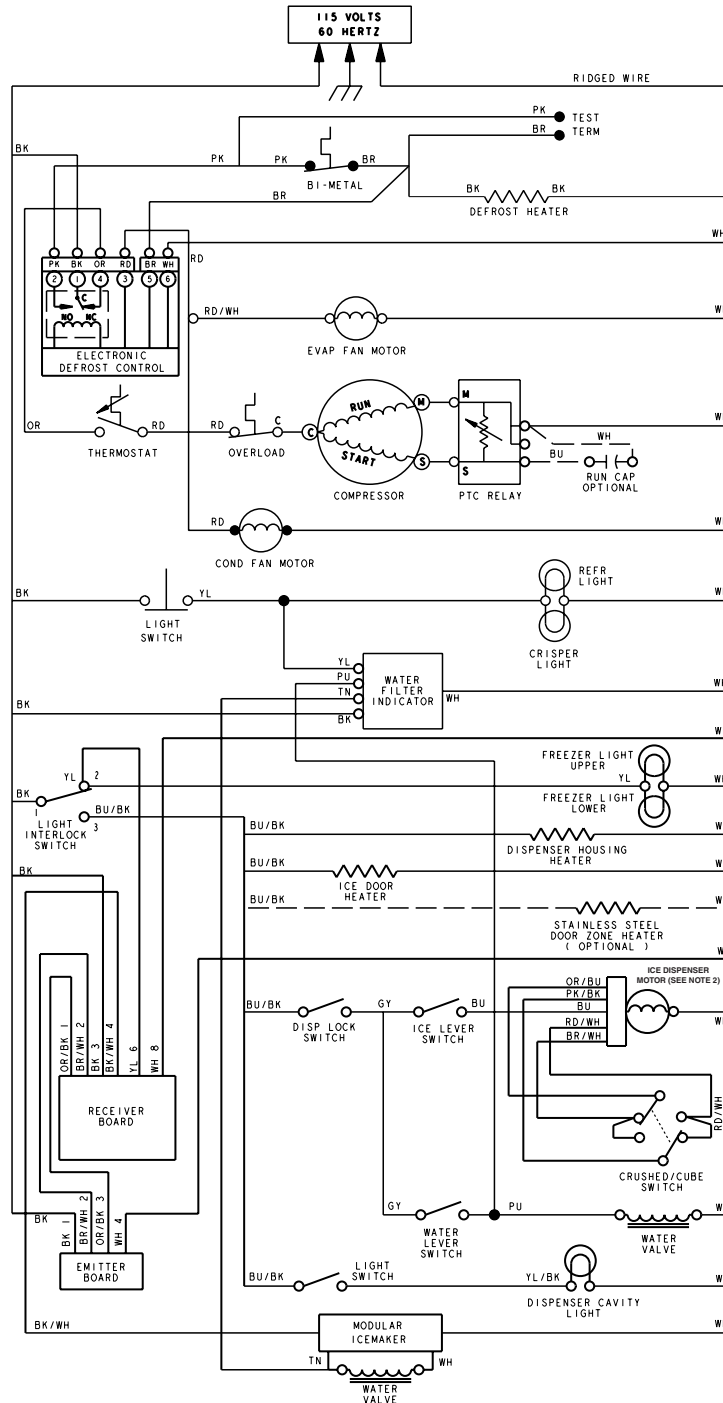

NOTES:

1. Freezer door is open, ice dispenser selection in Cubed mode, and dispenser lock switch in Locked position.
2. The dispenser has a built-in inverter board which converts the 115 VAC to 115 VDC. The OR/BU wire is the positive (+) side of the DC signal, and the PK/BK wire is the negative (-) side. The BR/WH and RD/WH wires switch polarity, depending on the crushed/cubed switch position, (see the following table).

	BR/WH	RD/WH
Crushed	-	+
Cubed	+	-

STRIP CIRCUITS

CRUSHED MODE

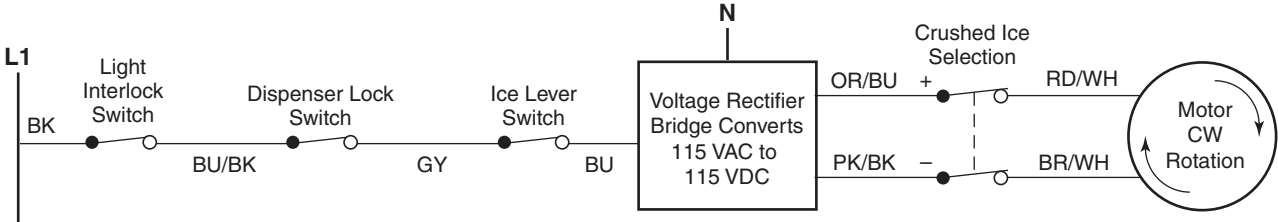

CUBED MODE

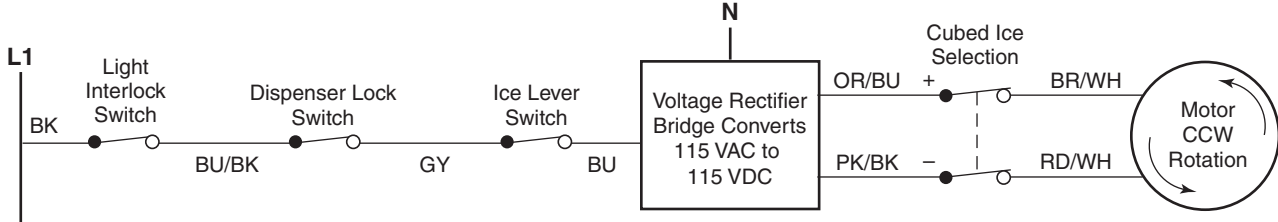

— NOTES —

- Trace the circuit for the cubed ice operation by closing the necessary switches. Refer to the Wiring Diagram NOTES at the bottom of the page.

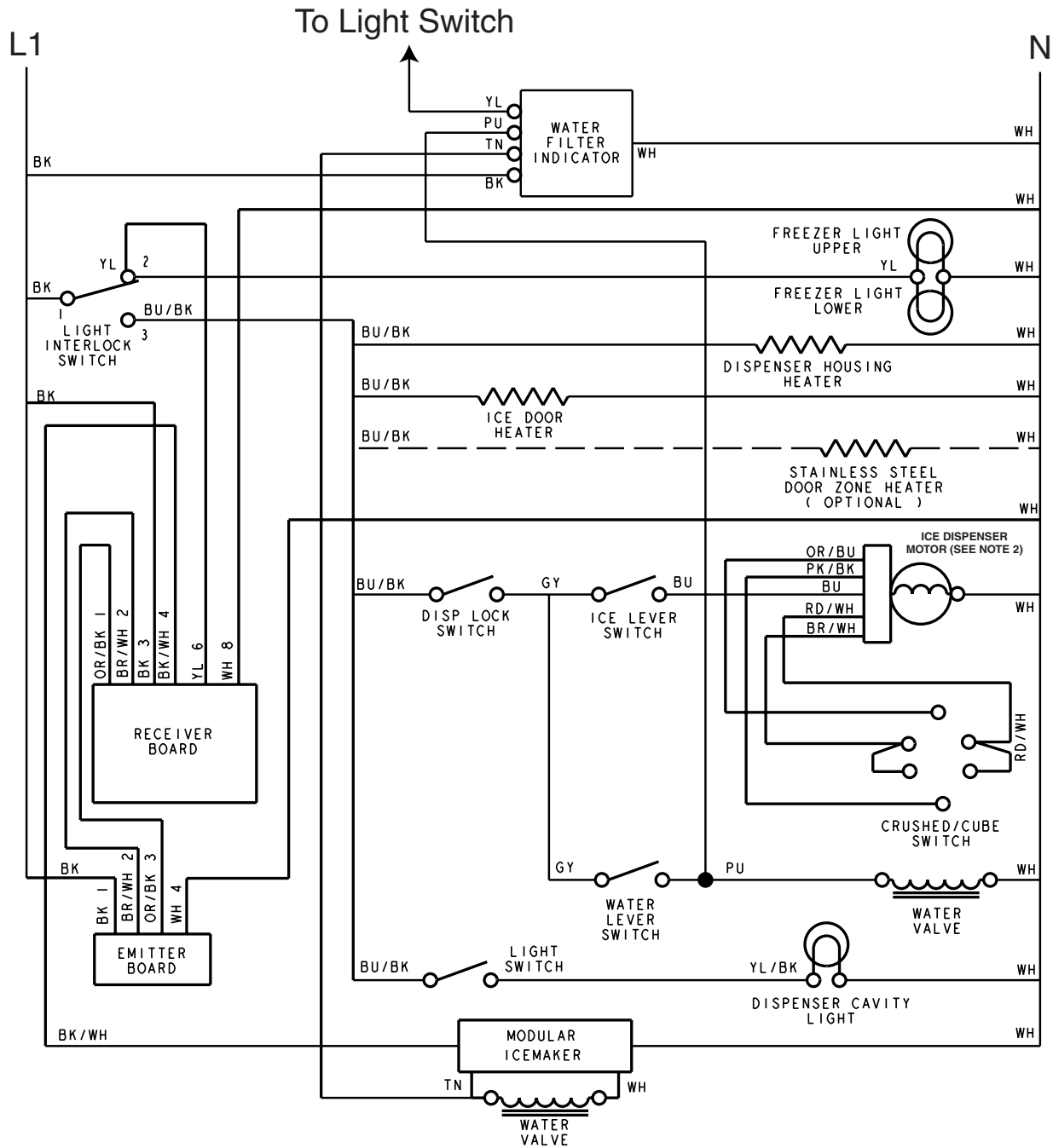

NOTES:

- Freezer door is open, ice dispenser selection in Cubed mode, and dispenser lock switch in Locked position.
- The dispenser has a built-in inverter board which converts the 115 VAC to 115 VDC. The OR/BU wire is the positive (+) side of the DC signal, and the PK/BK wire is the negative (-) side. The BR/WH and RD/WH wires switch polarity, depending on the crushed/cubed switch position, (see the following table).

	BR/WH	RD/WH
Crushed	-	+
Cubed	+	-

PRODUCT SPECIFICATIONS AND WARRANTY INFORMATION SOURCES

IN THE UNITED STATES:

FOR PRODUCT SPECIFICATIONS AND WARRANTY INFORMATION CALL:

FOR WHIRLPOOL PRODUCTS: 1-800-253-1301
FOR KITCHENAID PRODUCTS: 1-800-422-1230
FOR ROPER PRODUCTS: 1-800-447-6737

FOR TECHNICAL ASSISTANCE WHILE AT THE CUSTOMER'S HOME CALL:

THE TECHNICAL ASSISTANCE LINE: 1-800-253-2870

**HAVE YOUR STORE NUMBER READY TO IDENTIFY YOU AS AN
AUTHORIZED SERVICER**

FOR LITERATURE ORDERS:

PHONE: 1-800-851-4605

IN CANADA:

FOR PRODUCT SPECIFICATIONS AND WARRANTY INFORMATION CALL:

1-800-461-5681

FOR TECHNICAL ASSISTANCE WHILE AT THE CUSTOMER'S HOME CALL:

THE TECHNICAL ASSISTANCE LINE: 1-800-488-4791

**HAVE YOUR STORE NUMBER READY TO IDENTIFY YOU AS AN
AUTHORIZED SERVICER**

