

**Modular Ice  
Maker**

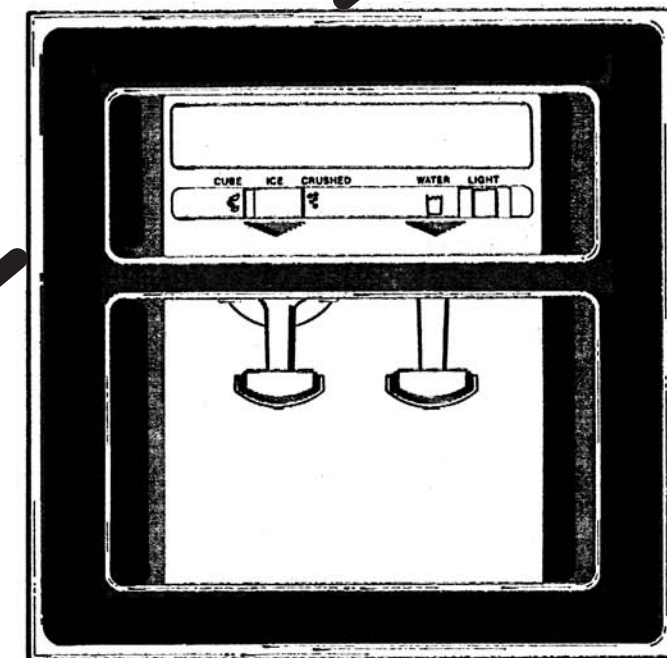

**Crushed Ice  
Dispenser**

JOB AID  
Part No. 4316835

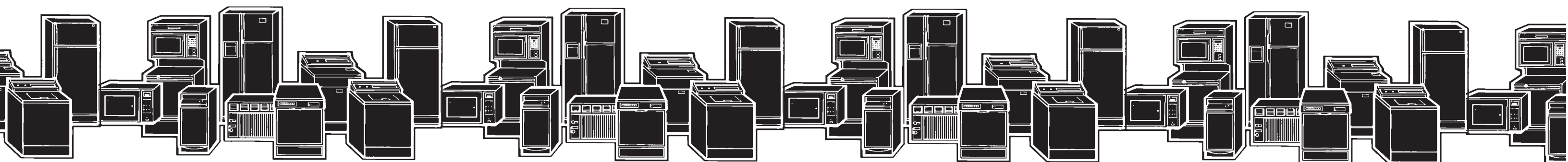

# *parts quality . . .*

**A**n important step in the appliance repair procedure is the selection of FSP® (FACTORY SPECIFICATION PARTS) as replacements. Use of “fits-all” or “look-alike” parts could result in early parts failure, safety hazard or substandard performance of the appliance . . . and an unnecessary repeat of your repair efforts.

To be sure that the part(s) you purchase meet the exacting quality standards used to build every new appliance, be sure to ask for genuine FSP replacement parts as specified for your model. FSP (FACTORY SPECIFICATION PARTS) is a registered trademark of WHIRLPOOL CORPORATION.

You can buy your genuine FSP (FACTORY SPECIFICATION PARTS) replacement parts from authorized Parts Distributors.

Ask for them by name . . . FSP!

## **Job Aid Objective**

This Job Aid is to familiarize the experienced refrigeration tech with the procedure for testing and repairing the redesigned compact ice maker.

## **Table of Contents**

	PAGE
■ MODULAR ICE MAKER	
Description & Testing Procedure . . . . .	1
Service Procedure . . . . .	2
Module Components . . . . .	3
Water and Temperature Problems . . . . .	4
Shut-off Arm Information & Harness Service . . . . .	5
Leveling . . . . .	6
Wiring Harness & Parts . . . . .	7
Wiring Diagram . . . . .	8
Parts . . . . .	9
■ CRUSHED ICE	
Operation . . . . .	10
Front Dispenser . . . . .	10
Motor Assembly . . . . .	11
Ice Container Assembly . . . . .	12
Ice Crusher Blade Assembly . . . . .	13
Diagnostic Hint . . . . .	13

**WHIRLPOOL CORPORATION assumes no responsibility for any repairs made on our products by anyone other than Factory Authorized Service Technicians.**

# *the redesigned compact ice maker*

The test holes are identified as "N," "M," "V," etc.

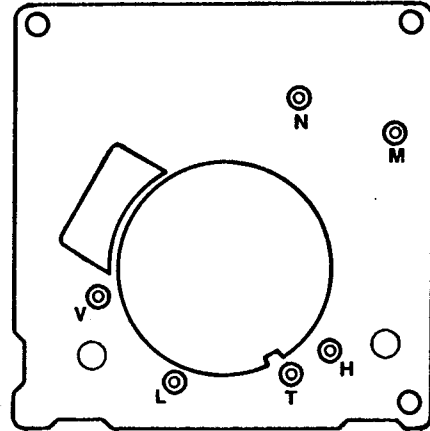
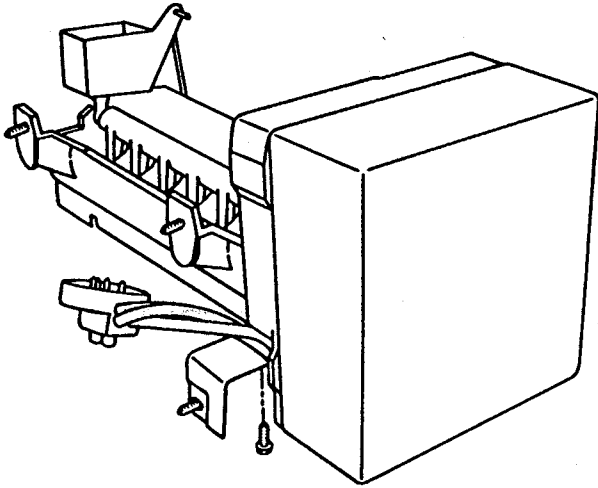

Although the ice maker looks about the same from the outside, some significant electrical design changes have been made behind the cover and in the control box area.

The design of this ice maker allows all of the components to be tested without removing the ice maker or moving the refrigerator away from the wall to access the water valve.

Remove the cover and you will see the test points identified on the module.

- N = Neutral side of line
- M = Motor connection
- H = Heater connection
- T = Thermostat connection
- L = L1 side of line
- V = Water valve connection

**NOTE:** Read this Job Aid completely before doing any testing or adjusting. Refer to tech sheet for complete testing information.

## *ice maker operation*

When the thermostat has sensed temperatures  $17^{\circ} \pm 3^{\circ}$ , the thermostat closes. At this time, the current now has a path through the thermostat to the motor (see wiring diagram). The motor is linked with the drive gear. From the module, there are copper contacts that ride on copper strips on the backside of the drive gear. As the drive gear rotates, these contacts from the module will make or break a circuit (track) to the copper strips to generate the ice maker cycle.

## *testing procedure*

### Ice Maker Plugged In To Power Shut-Off Arm Down-Freezer Cold

- Test points L & N will verify 120 volts to Ice Maker module.  
(Make sure your test probes go into the test points 1/2".)
- Test points T & H will verify if the bimetal thermostat is open or closed.  
Short T & H with an insulated piece of wire (14 ga.) to run the motor. If the motor doesn't run, replace the module assembly.  
If the motor runs, replace the bimetal thermostat.
- If you leave the jumper in for a half of a revolution, you can feel the heater in the mold heat up. . . . if it's good.

Remove the jumper and the water valve will be energized in the last half of the revolution.

(Make sure that the freezer temperature is cold enough to close the bimetal.)

**NOTE:** Do not short any contacts other than those specified. Damage to ice maker can result.

### Ice Maker Unplugged

- Test points L & H will check the resistance of the heater (72 ohms). Replace the mold and heater assembly if not near this value (+ or - 10 ohms).  
(Ejector blades should be at the end of the cycle position.)
- Test points L & M will check the resistance of the motor (4400 ohms). Replace module assembly if not near this value (+ or -10 ohms).  
(Module must be separated from heater before testing.)

## ***service procedures***

### **COVER—**

Pull water adjustment knob first and snap off cover. Index knob and reinstall in same position for same water fill.

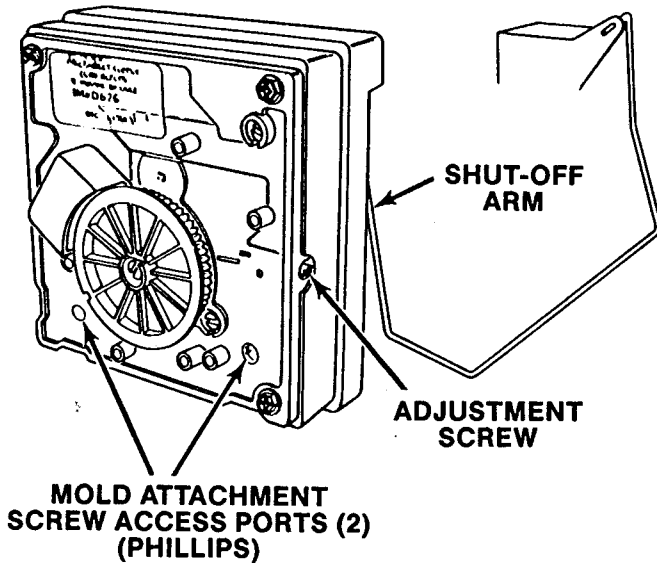

### **MODULE, MOTOR AND SUPPORT ASSEMBLY—**

Insert phillips driver in access ports in module. Loosen both screws. Disconnect shut-off arm. Pull mold from support assembly. To remove module only, remove 3 phillips screws and pull module out of housing.

### **SHUT-OFF ARM—**

Pull out from white bushing. Reinsert to full depth. See page 5 for detailed procedure.

### **MOLD & HEATER—**

Remove module and support assembly. Install on new mold & heater assembly.

### **THERMOSTAT—**

Remove module and support assembly. Pull out retaining clips with bimetel. See page 4 for detailed explanation.

### **FILL CUP—**

Remove module and support assembly. Remove ejector blades and shut-off arm. Pull fill cup up from mold. See page 6 for complete procedure.

### **EJECTOR BLADES OR STRIPPER—**

Remove module and support assembly. When reinstalling ejector blades, realign "D" coupling with module cam.

## ***accessing the control box***

To remove motor and contact assembly from control box, take out 3 screws (arrows) and pull free after disconnecting the shut-off arm.

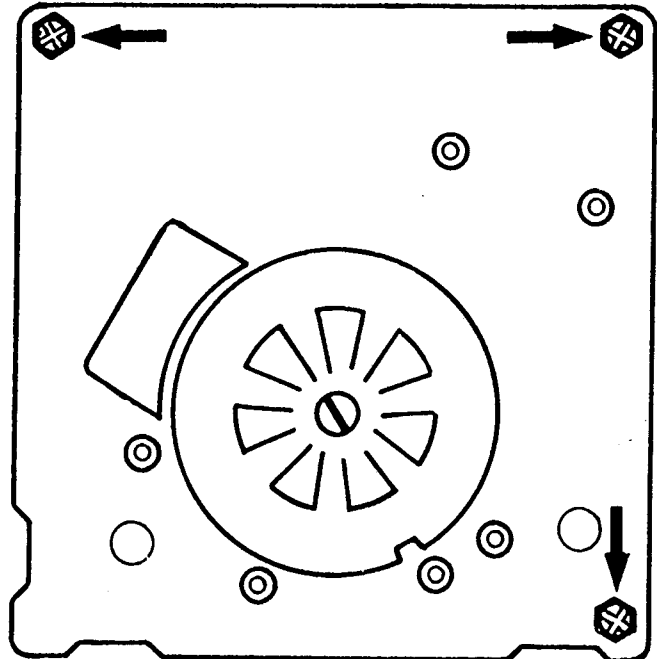

### **—CAUTION—**

NEVER ROTATE THE BLADE OR THE DRIVE GEAR... IT WILL RUIN THE MAIN ASSEMBLY. (There are several switches which will jam if manually turned counterclockwise and the gears will be destroyed if turned clockwise.) If you need to advance the ice maker into the cycle, use a jumper to bridge T to H and unless the motor is defective, it will run. (The shut-off arm must be in the on position.)

NOTE: There are several slotted shafts on the motor assembly board. Do not under any circumstances insert a screwdriver and attempt to turn these shafts. The slots are to permit assembly only.

NOTE: There are no repairable or replaceable components in the module. Unless you are replacing the module, there should be no need to remove it when diagnosing or repairing the ice maker.

# module components

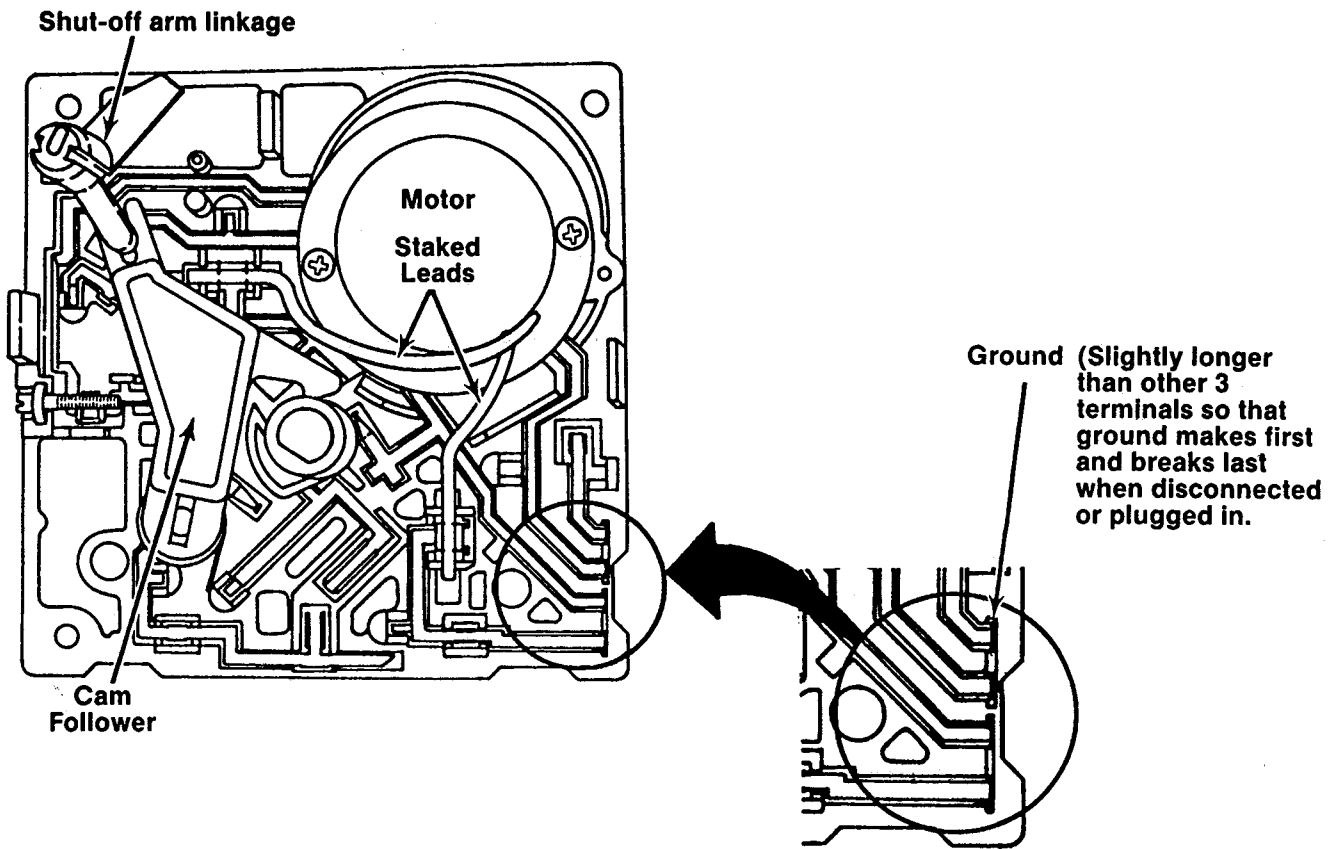

# what happens during blade rotation

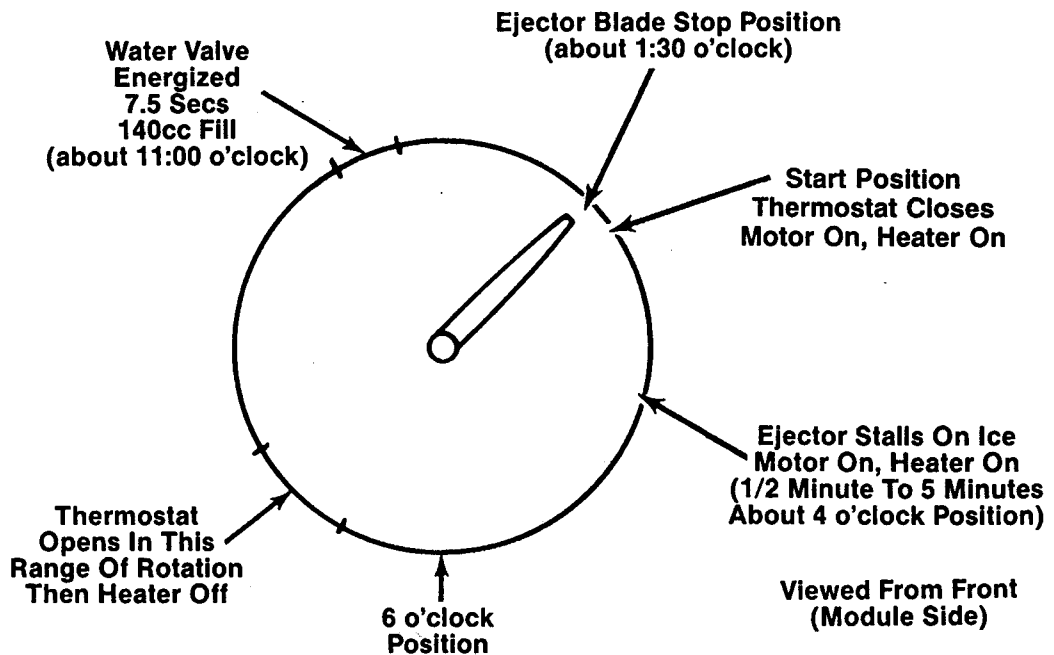

NOTE: Incorrect readings may be obtained if blades are past rest position.

## water fill adjustment

Turning the water level adjustment screw will move the contact in its relationship with the contact ring segment. This causes the contact to vary the time that the water valve is energized, since the contact ring is tapered at the end of the fill time.

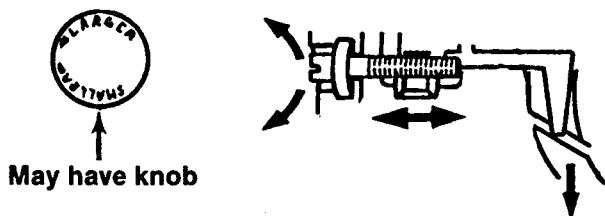

Turning the knob or screw clockwise decreases fill; counterclockwise increases the fill amount.

Only one revolution is possible with the cover on due to a stop molded on cover.

360° will affect fill by 40cc. 180° varies the fill by 20cc.

Further adjustment could damage module.

If water valve adjustment screw falls out, just put it back in and align the hole in the hole as shown.

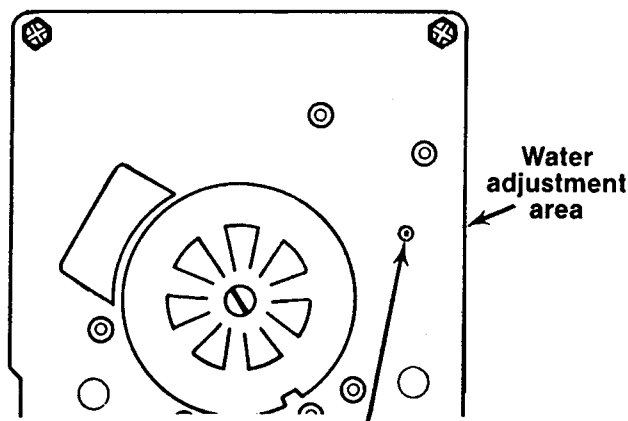

When small hole is centered in larger hole the water fill adjustment is for 7.5 seconds fill time (normal).

Note: Some ice makers will have a water adjustment knob. Pull off the knob to remove cover. Be sure to replace knob in same setting position.

## water problems

Water quality can cause ice makers to fail, or produce unacceptable cubes. If mineral content or sand is a problem, the screen in the fill valve can restrict, or a particle of sand can keep the valve from seating properly. Results will be small crescents (or no ice) or flooding of the ice container if the water valve does not close.

Mineral content can also lime up the mold, causing wicking of water over the mold and poor cube release. Silicone is applied at the upper edges, around fill cup & stripper.

## temperature problems

Temperatures in the freezer section which average above the normal of  $0^{\circ} \pm 5^{\circ}$  will slow the production of ice. Complaints of inadequate crescent production may be corrected by simply setting the freezer to a colder temperature. The thermostat cycling temperature in this 1-revolution ice maker is  $17^{\circ} +$  or  $-3$ . Obviously, the ice will be well frozen when these temperatures are achieved but cycling time will be slowed if the freezer temp is not cold enough to achieve these mold temperatures easily.

**NOTE:** Only the thermostat, mold, with heater & wiring harness are replaceable. Any other failure (including the motor) requires replacement of the module assembly. If you are replacing the mold assembly, it comes with a new mold heater installed.

External plastic parts are also replaceable.

A failed mold heater requires complete replacement of the mold and mold heater assembly.

## to service thermostat

If the thermostat is diagnosed as defective, it can be removed and replaced easily. Remove the control box from the mold by taking out two Phillips screws.

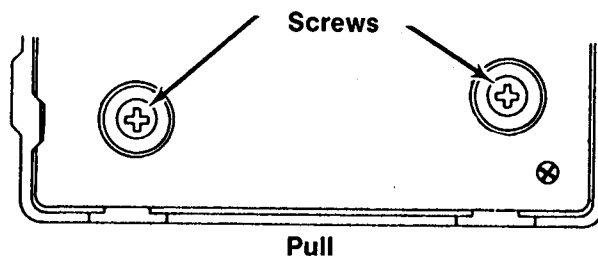

(Front of Black Housing)

Pull the housing free of the mold, and you will see the thermostat on mold side.

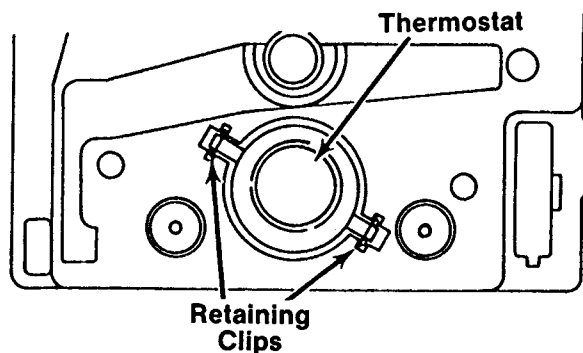

Using needle nose pliers, grasp one of the thermostat clips and pull out. Press in new thermostat, making sure that pins are properly indexed. Using this procedure, it is not necessary to remove the electrical assembly. If you are replacing the module, transfer the clips to the new mold support. (Use new thermal bonding material.)

# shut off arms

## SHUT OFF ARM SIZES

### SHORT ARM—REGULAR I/M

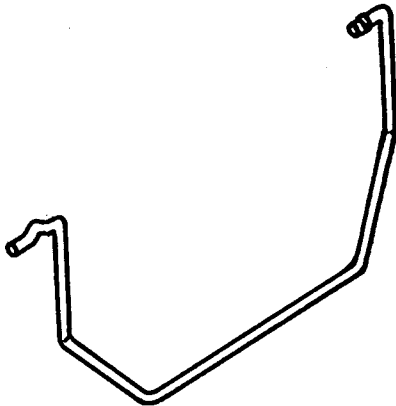

### LONG ARM—DISPENSER MODELS

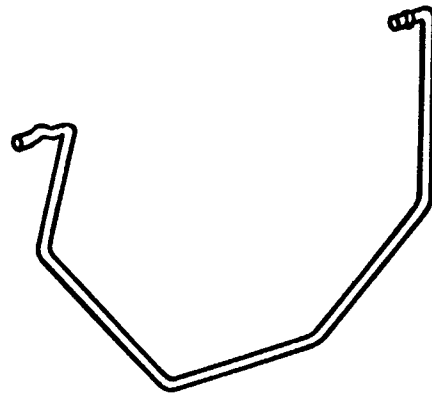

Make sure  
you select  
the correct arm

## INSTALLATION PROCEDURE (Same for both arms)

### SHUT OFF ARM INSTALLATION INSTRUCTIONS

- I. Start with arm in "down" position.
- II. Follow steps 1, 2 & 3.

**1. Push arm into center slot  
in white bushing—bottom out**

Water  
adjustment  
knob  
location  
(not on all  
models)

**3. Arm should be inside  
edge of housing**

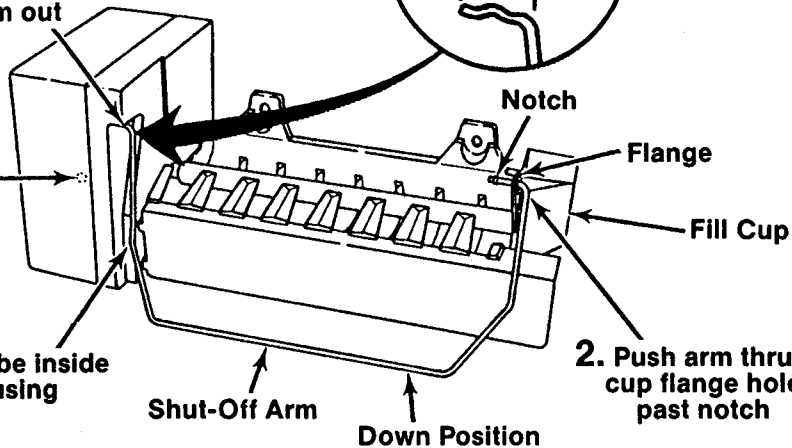

**2. Push arm thru fill  
cup flange hole  
past notch**

## to service harness

To remove the wiring harness, depress the retaining tab and pull the plug free.

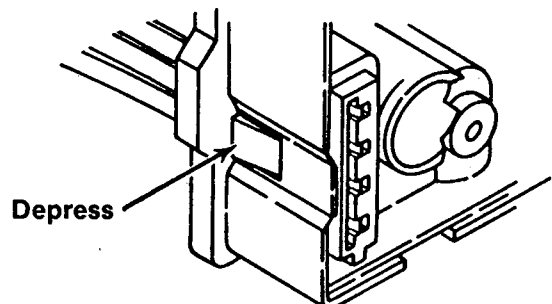

# leveling of icemaker

ASSURES UNIFORM ICE  
CRESCENTS

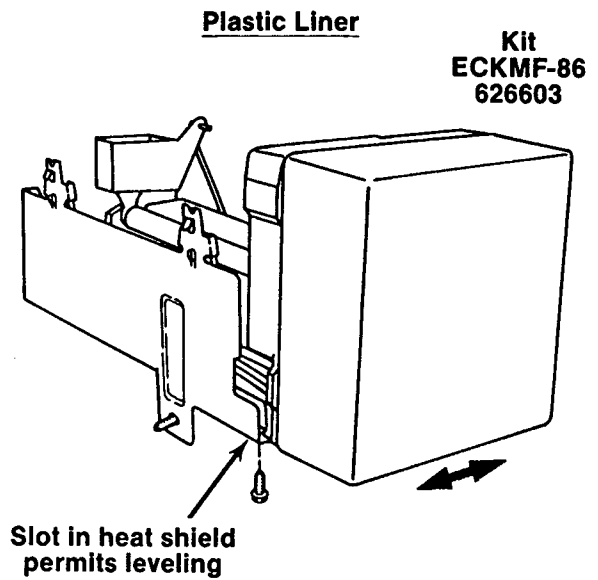
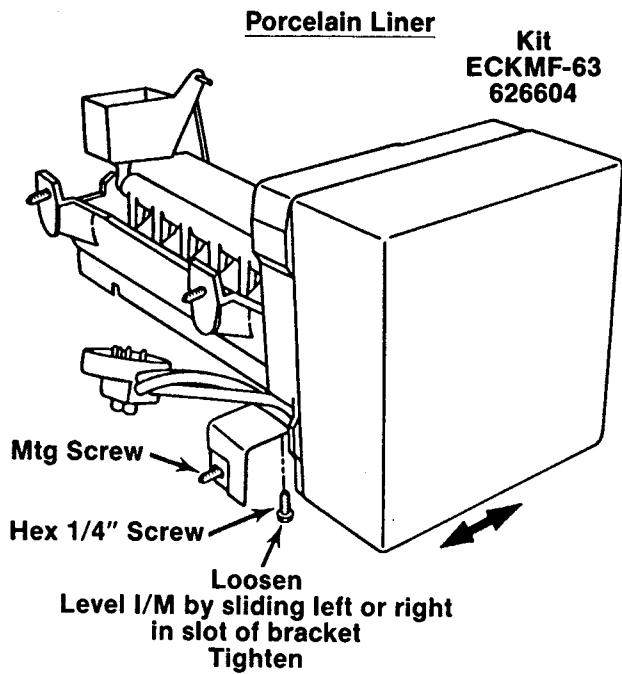

Make sure refrigerator is level front to back. (Adjust legs or rollers.)

## removing & replacing fill cup

To remove fill cup you must separate mold and blade  
from module housing. Remove blade from fill cup.

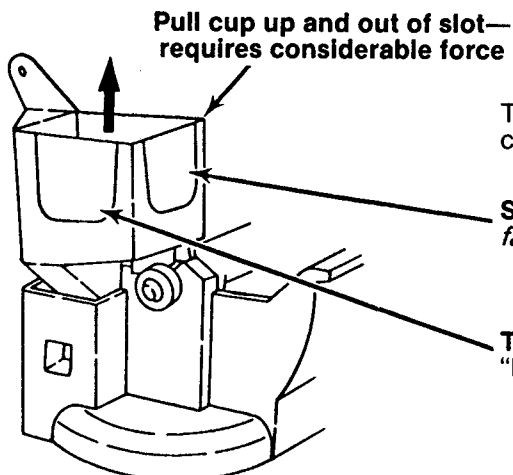

The appropriate "break-out" plug needs to be the fill  
cup for your specific model. Check old ice maker.

**Side-by-Side Models:** remove "break-out" from fill cup  
*facing side wall.*

**Top freezer and bottom freezer models:** remove  
"break-out" from fill cup *facing rear wall* of freezer.



# wiring harnesses

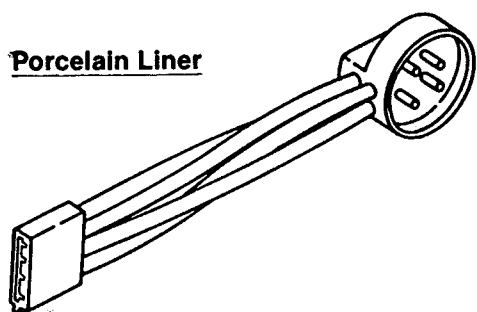

**Porcelain Liner**

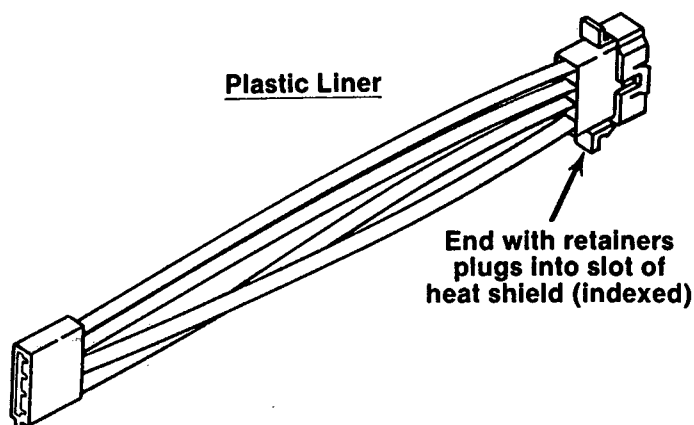

**Plastic Liner**

End with retainers  
plugs into slot of  
heat shield (indexed)

This harness plugs directly into liner receptacle.

Original production for plastic liner models had a heat shield to protect the liner from the heat of the mold heater. This heat shield has been replaced with a thermo-fuse.

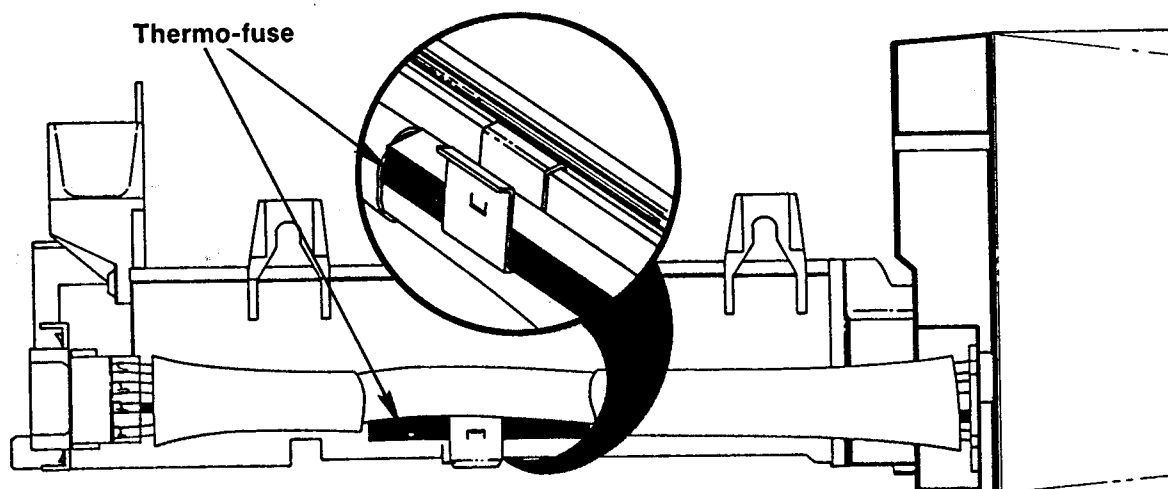

The thermo-fuse is spliced into the black wire of the ice maker wiring harness. It is a 170°F non-resettable fuse. A no ice complaint could be caused by excessive heat. Replacing only the wiring harness will only temporarily solve the complaint. The ice maker thermostat should also be replaced.

*NOTE: Currently wiring diagrams do not show the thermo-fuse.*

## other information

Motor connectors can be damaged if leads are removed.

The motor is available only as part of the complete module assembly.

1 revolution of blade takes 3 minutes (+ stall time on ice).

Bench test cord can be made from cabinet socket.

Tan & white wires on socket plug are the water valve leads.

## specifications

MOLD HEATER—185 Watts, 72 ohms

THERMOSTAT (BIMETAL)—Close 17° ± 3°  
Open 32° ± 3°

WATER FILL—140cc, 7.5 sec.

MOTOR—3 Watts, 4400Ω

MODULE—Stamped circuit, Plug-in connectors

CYCLE—One revolution (ejects & water fill)

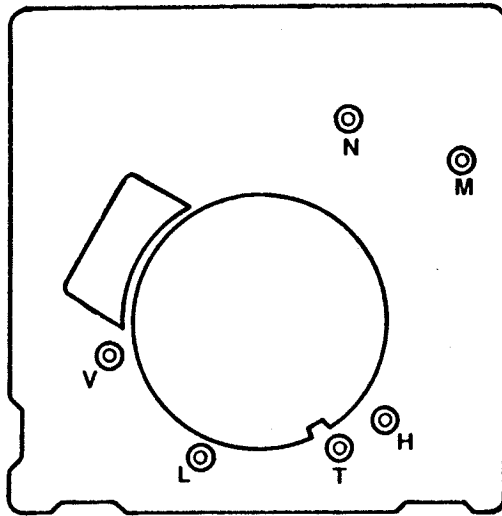

**TEST POINTS**

- H-T → Thermostat
- L-H → Heater
- L-M → Motor
- L-N → 115V
- V-N → Valve

**wiring diagram**

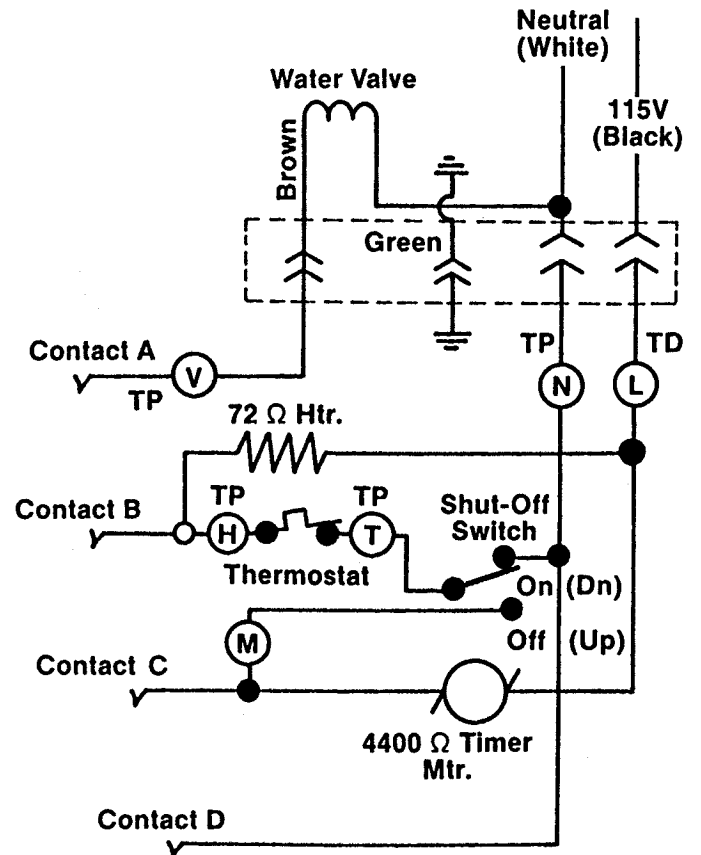
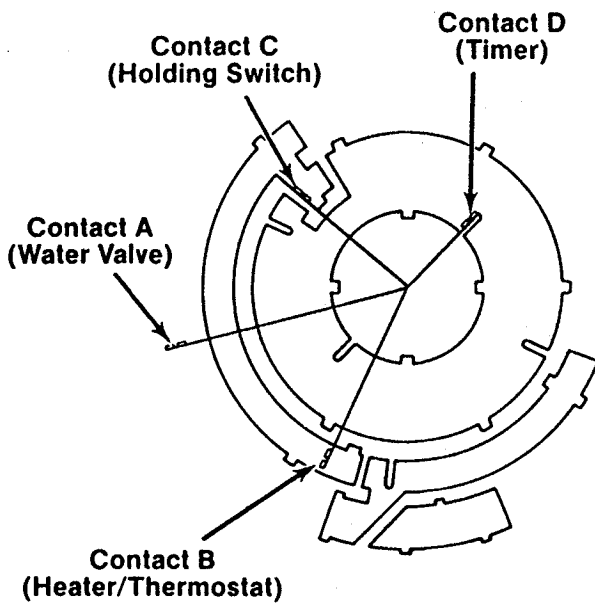

# ICEMAKER PARTS

For Model: ECKMF-90  
1127599.

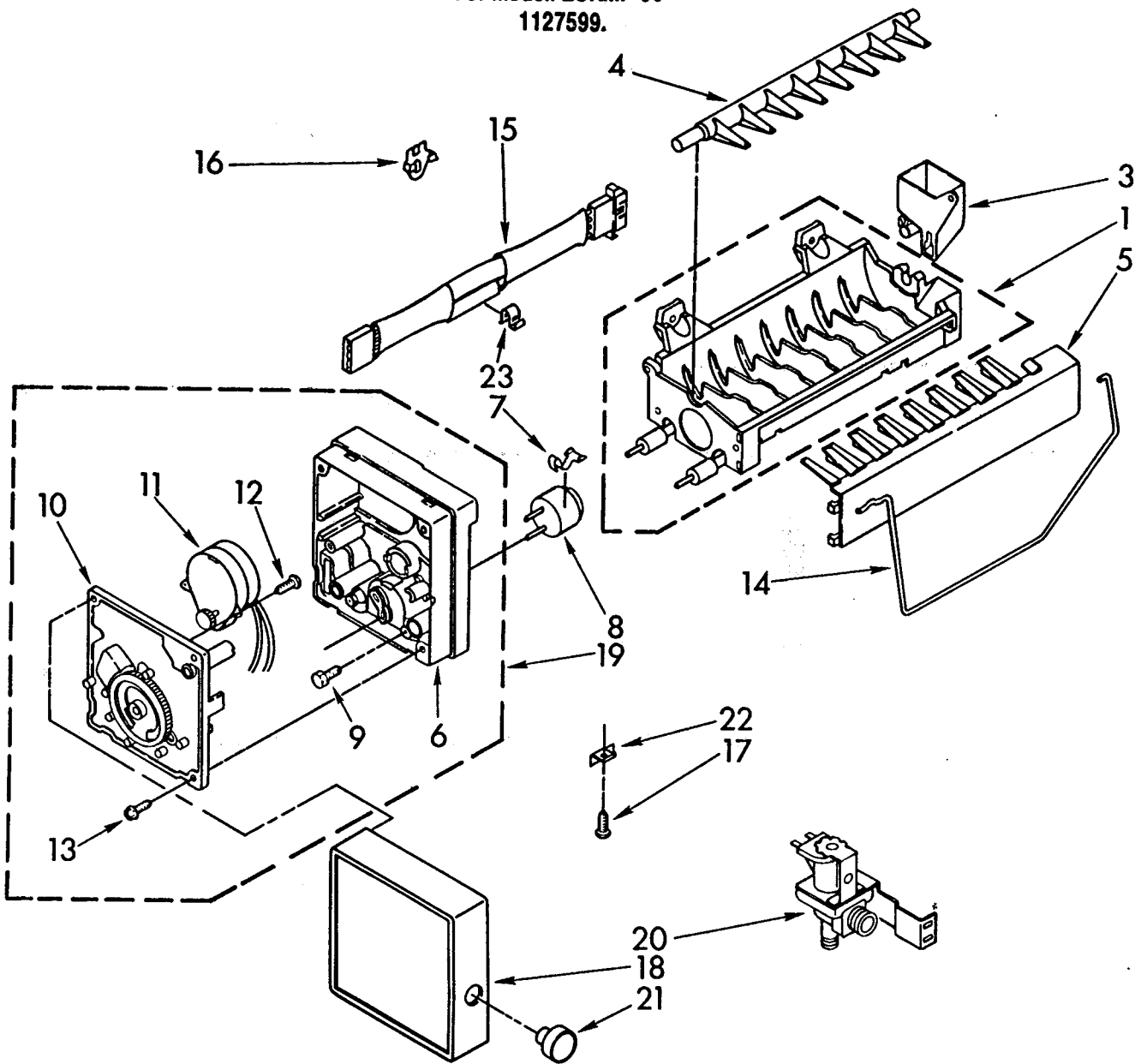

Illus. No.	Part No.	DESCRIPTION	Illus. No.	Part No.	DESCRIPTION
1	628228	Mold & Heater Assembly	13	489276	Screw, (3)
3	627791	Bearing & Inlet	14	627792	Shutoff Arm
4	627843	Ejector	15	628256	Wiring, Harness
5	627788	Ice Stripper	16	627712	Clip, Ice Maker
6	627790	Support	17	489128	Screw, 8-32 x 27/64
7	627796	Retainer, Thermostat (2)	18	1116224	Cover
8	627985	Thermostat (Also Order 542369 Cememnt Alumilastic)	19	483042	Module Assembly (Includes Items 6, 9, 10, 11, 12 & 13)
9	489258	Screw, (2) 10-32 x 49/64	20	627929	Valve, Solenoid
10	628247	Module, Assembly	21	627992	Knob, Water
11	627811	Motor	22	628229	Bracket
12	489136	Screw, (2) 3-24 x 23/64	23	628170	Clip, Thermal Fuse

# ICE CRUSHER DISPENSER

Modifications have been made to certain side-by-side ice dispensing models to create a new ice crushing feature.

An ice deflector forces the ice cubes into the crusher blades. A microswitch behind a slide switch on the front cover of the dispenser activates a solenoid that operates a control arm which retracts the ice deflector into a position allowing ice cubes to be dispensed without going through the ice crusher blades.

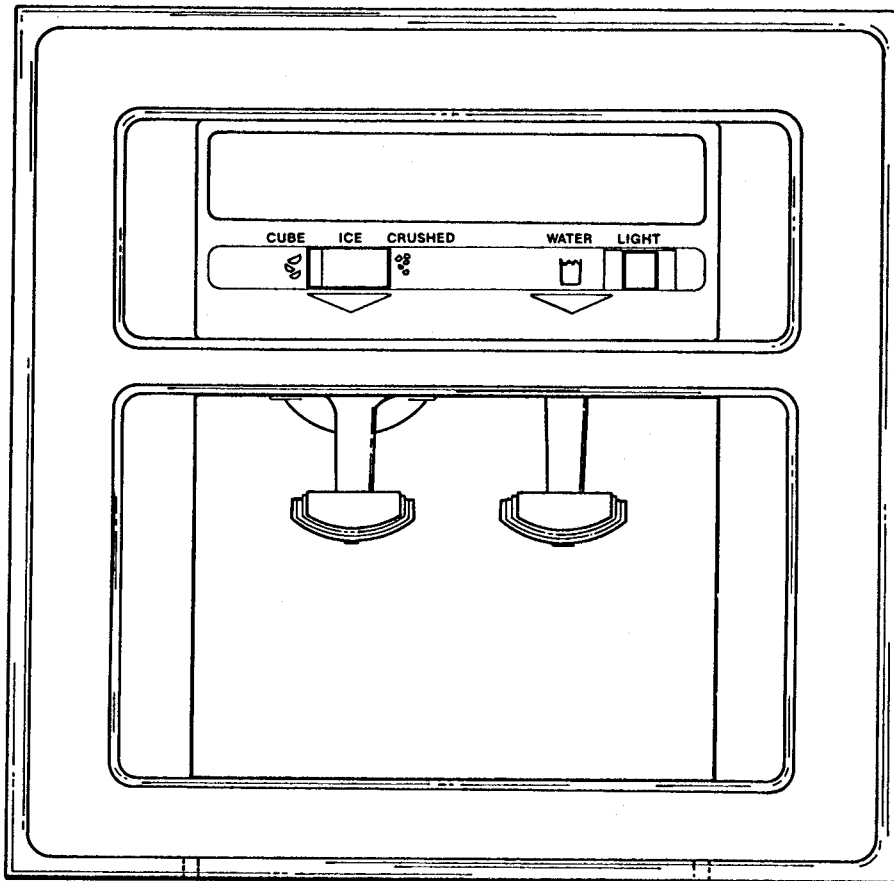

## ***front dispenser***

- The front dispenser cover can be removed by inserting a screwdriver blade into the two slots on the bottom side of the cover. By gently turning the blade, the cover will snap free at the bottom and can be slid upward to be removed.
- The microswitch that activates the solenoid to disengage the ice crusher can be inspected by removing 3 screws that secure the plastic slide frame and 2 screws that secure the metal control bracket. When replacing the control bracket, care should be exercised not to pinch the wiring harness.

*NOTE: The cube/crush microswitch is interlocked with the freezer light switch located on the inside of the freezer door frame. When the freezer door is open, the freezer light switch must be held in to allow the microswitch to activate the solenoid.*

# *motor assembly*

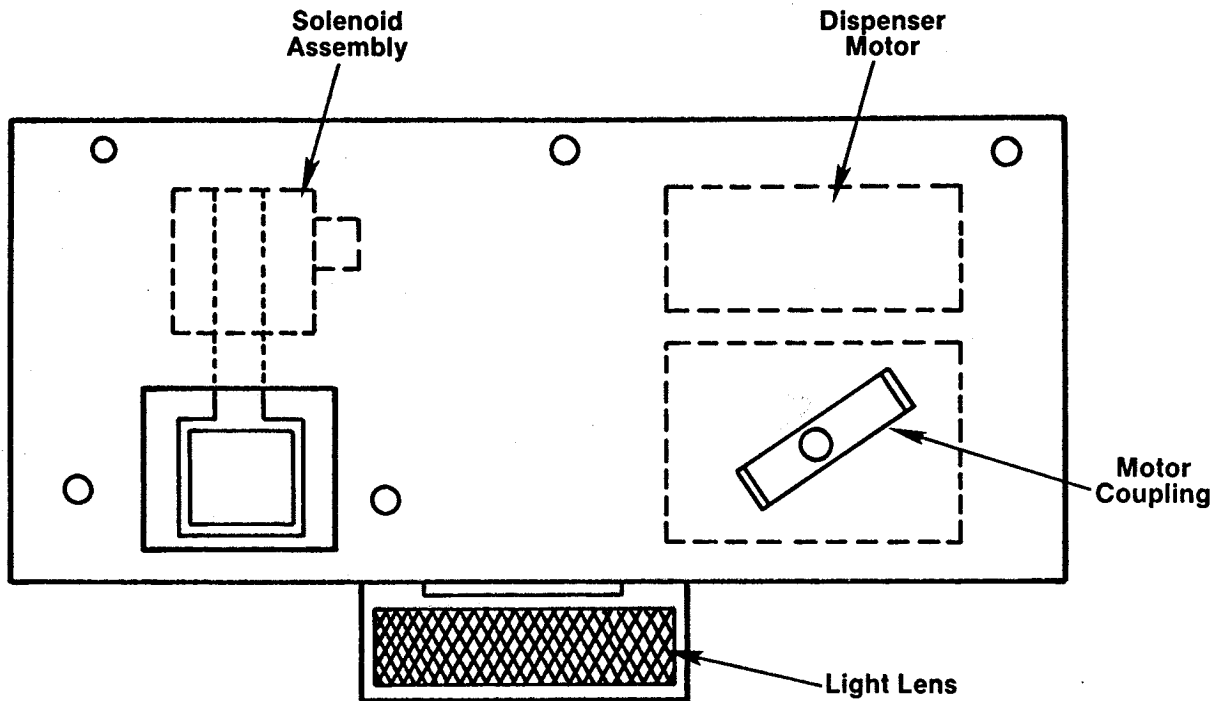

- The solenoid that disengages the ice crusher is mounted alongside the dispenser motor on the motor bracket. It is not necessary to remove the motor bracket to check if the solenoid is properly functioning. The plunger in the solenoid assembly that moves the control arm can be clearly seen through the opening on the front of the motor bracket.
- To replace a solenoid, the motor bracket must be removed. To assemble the solenoid assembly, the plunger must be inserted into the bottom of the assembly, twisted until the shear pin holes are aligned on both the plastic plunger and the metal shaft of the solenoid, and the shear pin re-inserted.

# *ice container assembly*

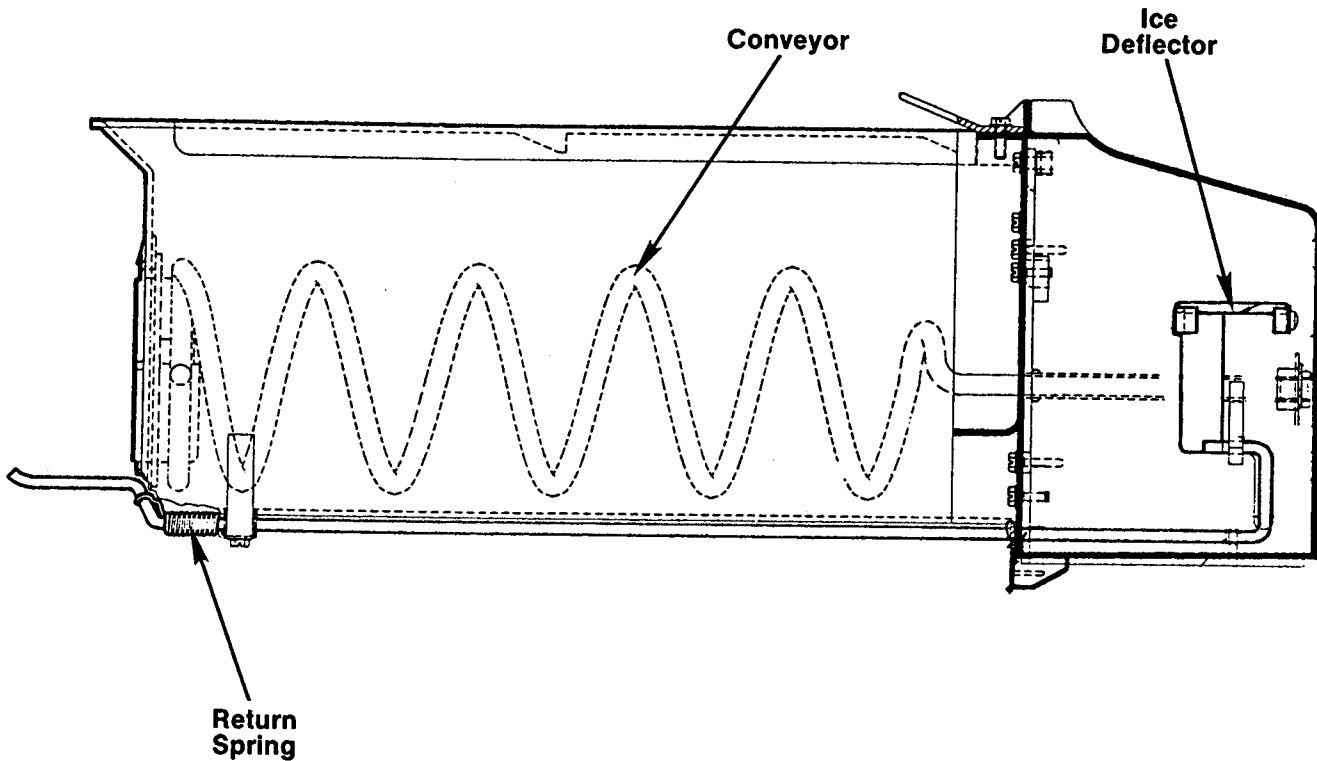

- A steel control arm runs alongside the ice container in connecting the ice deflector in the crusher housing with the solenoid assembly. When the solenoid is activated (Ice Cube mode), the control arm retracts the ice deflector, allowing the ice cubes free access through the dispenser, bypassing the crusher blades. When the solenoid is deactivated (Crushed Ice mode), the ice deflector moves back into place, forcing the ice cubes exiting through the drum into the crusher blades.
- The crusher housing can be removed by releasing the retaining ring and removing the metal washer on the conveyor shaft where it protrudes through the front of the crusher housing.

# ice crusher assembly

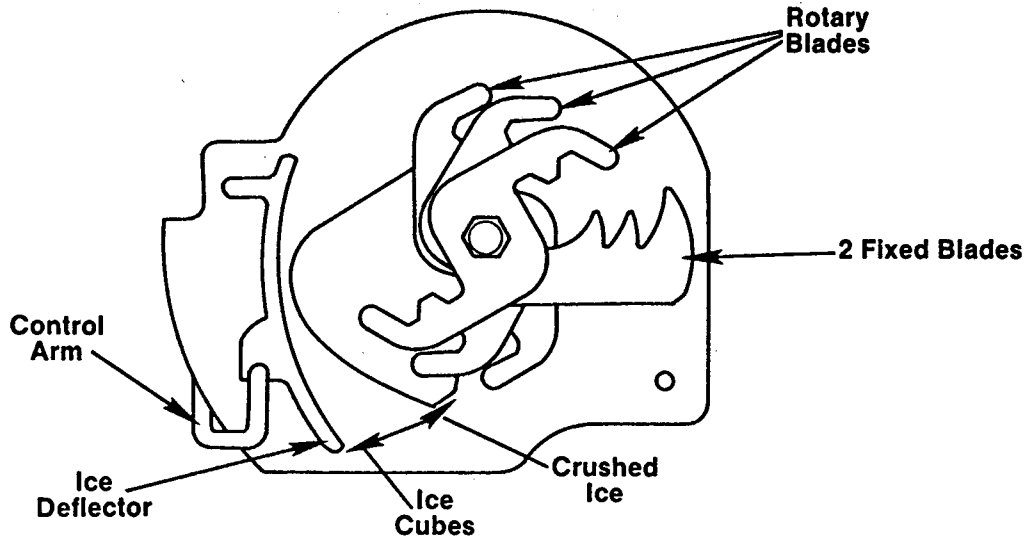

- The crusher blade assembly can be disassembled by removing the plastic locknut on the end of the conveyor shaft.

# blade assembly

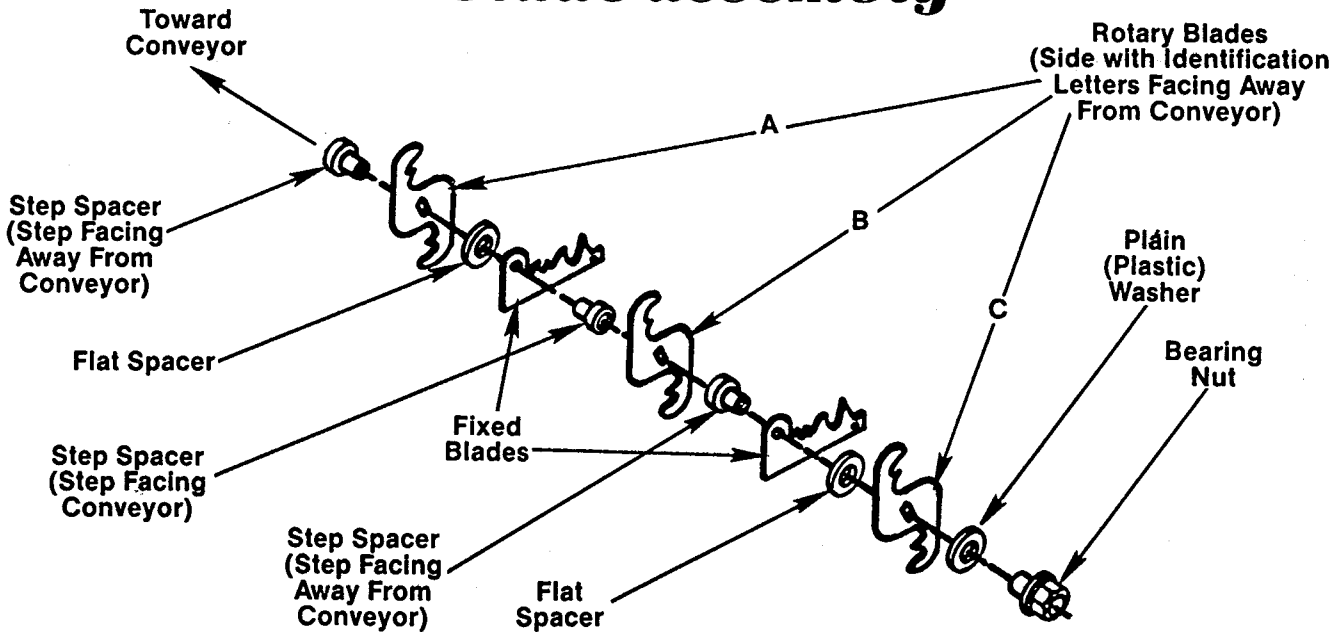

**NOTE:** The plastic locknut has reversed threads. When reassembling the crusher blade assembly, it is important to assemble the various spacers, washers, rotary blades and fixed blades in the proper sequence. When assembled, the rotary blades must rotate evenly through the slots of the stationary blade block.

- When reassembling the crusher housing, the return spring on the control arm must be positioned so that the control arm holds the ice deflector in toward the crusher blades (Crushed Ice mode).

**DIAGNOSTIC HINT:** If the ice dispenser will only dispense crushed ice, the ice deflector is not retracting. The cube/crush microswitch and solenoid should be checked to see if they are functioning properly.