

**SERVICE NOTE BOOK
UNDERCOUNTER ICE MAKER**



VIKING RANGE CORPORATION

TABLE OF CONTENTS

| | |
|--|----|
| Product Specifications..... | 2 |
| Safety Considerations..... | 3 |
| Installation and Maintenance..... | 4 |
| Operation..... | 14 |
| Wiring Diagram..... | 16 |
| Component Access and Testing..... | 25 |
| Components in Control Panel Area..... | 26 |
| Components in Bin Area..... | 29 |
| Components in Unit Compartment..... | 33 |
| Problem Diagnosis..... | 38 |
| Troubleshooting..... | 41 |
| Wiring Diagrams and Line Circuits..... | 45 |

Product specifications

| | |
|-------------------|--|
| Height | 34-13/32" |
| Width | 17-7/8" |
| Depth | 23-7/8" |
| Shipping Weight | 122 lbs. |
| Net Weight | 114 lbs. |
| Avg. Ice Making | 50#-6600 Cubelet |
| Capacity/ 24 hrs. | 70* Amb.-60* Water |
| Storage | 35# |
| Capacity | 4620 Cubelets |
| Electrical | 120 Volts |
| Requirements | 50/60 HZ. AC |
| Avg. Power | 250-300 |
| Consumption | Watts |
| Compressor | 1/5 HP Piston |
| Refrig. Charge | R-134 A |
| Refrigerant | Capillary |
| Control | Tube |
| Water Control | Solenoid W/Flow Washer In Unit Comp. |
| Condenser Fan | 5-Blade Plastic |
| Condenser Fan | 3-Watt Output |
| Motor | 1200RPMs |

SAFETY CONSIDERATIONS

It is very important that power is disrupted to the ice maker before components are accessed for testing or replacement. However, when the ice maker is installed under a countertop, it is usually not convenient, nor necessary, to remove the unit in order to unplug it from the wall receptacle.

In order to verify that power has been disrupted to the unit:

1. Turn the service control switch to the “ON” position.
2. Verify that power is available to the ice maker. Listen for sounds of the compressor running, the water pump operating, water entering the unit, etc. Feel the grid wires to see if they are warm.
On units with a bin light, open the bin door and verify the light is operating.
3. Remove the fuse, or throw the breaker, on the electrical circuit providing power to the ice maker.
4. Verify that power has been disrupted.
(Use tests in No. 2 above.)
5. Turn the service control switch to the “OFF” position.

When servicing a unit that has been recently operating, the tubing of the high side (condenser area) of the refrigeration sealed system may be very hot.

If using an electric drill to tap into the water supply line, the drill must be properly electrically grounded to avoid possible shock. (See page 6)

When installing the ice maker, verify that the unit is properly electrically grounded.

Care must be exercised when cleaning the ice maker. Ice maker cleaning solutions must be handled properly. And while cleaning the condenser in the unit compartment, be careful not to touch the tubing or condenser fins. (See pages 13)

Be sure to wear gloves when handling the fiberglass insulation inside the ice maker. (See page 13)

Installation and Maintenance

Location

1. The unit may be closed in on the top, rear, and two sides: but the front **MUST BE** unobstructed for air circulation and proper operation. Installation should be such that the cabinet can be moved forward, if necessary.
2. Area should be well ventilated with temperature above 55°F (13°C) and below 110°F (43°C). **Best results are obtained between 70°F (21°C) and 90°F (32°C).**

This unit **MUST** be installed in an area protected from the elements, such as wind, rain, water spray or drip.

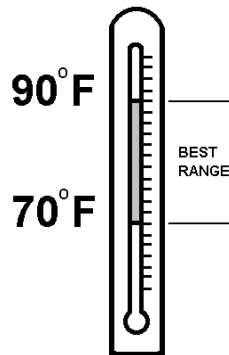

2. The unit must be installed in an area protected from the elements, such as wind, rain, water spray or drips.
3. Provisions for electricity, water and drain should be determined.



WATER

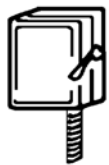

ELECTRICITY



DRAIN

Electrical Requirements

WARNING

Electrical Shock Hazard

Electrical ground is required on this appliance.

Check with a qualified electrician if you are in doubt as to whether the appliance is properly grounded. **DO NOT** modify or remove the power supply cord plug. If it will not fit the outlet, have a proper outlet installed by a qualified electrician.

Improper connection of the equipment-grounding conductor can result in a risk of electrical shock.

DO NOT use an extension cord with this appliance.

DO NOT have a fuse in the neutral or grounding circuit.

DO NOT connect to electrical supply until appliance is permanently grounded.

Failure to follow these instructions could result in fire, electrical shock, or other personal injury.

The unit will require an electrical branch circuit of 120 VAC/60Hz/1 phase with a 15 amp delayed action fuse or circuit breaker.

It is recommended that the ice maker is the only appliance plugged into the receptacle. **DO NOT** use a receptacle that is controlled by a switch.

ELECTRICAL GROUND IS REQUIRED ON THIS APPLIANCE. DO NOT, UNDER ANY CIRCUMSTANCES, REMOVE THE POWER SUPPLY CORD GROUND PRONG.

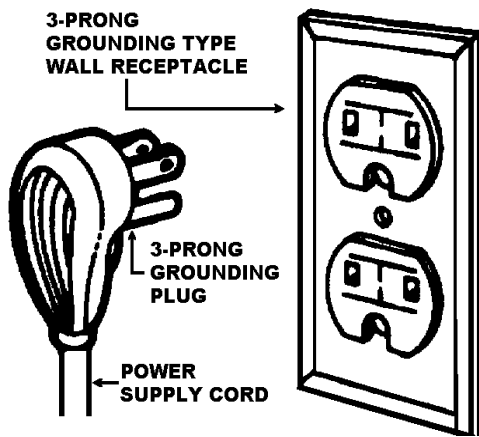

Check local codes for alternative grounding methods that may be used where a mating 3-prong grounding type wall receptacle is not available.

Water Connections Requirements

Materials can be obtained locally at a plumbing supply house. **DO NOT** use plastic tubing because it becomes brittle with aging.

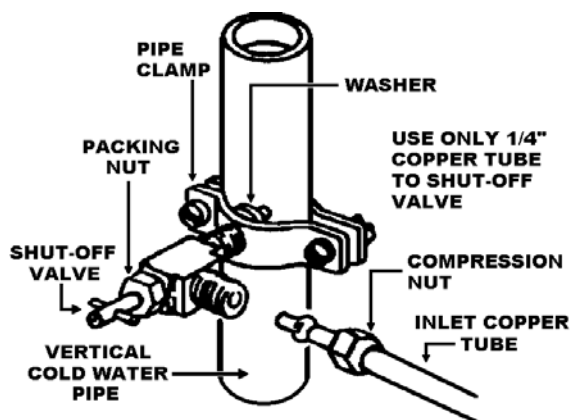

DO NOT use a self-piercing type or 3/16" saddle valve because they reduce water flow and clog more easily.

For proper operation, the ice maker should be connected to an active water supply line delivering cold water at pressures between 20 and 120 pounds per square inch.

CAUTION

Damage Hazard – Product / Property

DO NOT install copper tubing in an area where temperatures drop below freezing.

To do so may result in water damage.

Installation of line tapping devices and / or shut off valve.

1. Select the point on an active cold water supply line convenient to the unit where the connection is to be made. A point on a vertical section of 1/2" or 3/4" line leading to the kitchen sink is ideal. If installed on a horizontal line, place valve on top or side of line, never on the bottom. (this will keep water away from the drill during installation and also helps normal sediment from collecting in the valve.) Turn off the water supply and clear the line of pressure.

WATER LINE ASSEMBLY

Read all directions carefully before you begin.

WARNING

Electrical Shock Hazard

Electric drill must be grounded to prevent severe or lethal shock if water is in line and enters drill during use. FAILURE to ground drill may result in personal injury.

2. Provide a length of 1/4" OD copper tubing for connecting the Icemaker to the water supply. To determine the length, measure distance from the unit to the connecting point on the supply line and add approximately three feet to allow for connecting to the water valve in the unit. Be sure both ends of the copper tubing are cut square.
3. Drill a 1/8" hole in the water supply line at point selected for making connection. Care must be taken to drill a clean hole perpendicular to the wall of the supply line. If the line runs horizontal, drill the hole in the side or top, never in the bottom. Be sure the electrical drill is grounded, or use a hand drill to avoid shock.
4. Be sure the shut-off valve is in the OFF position. Turn clockwise until the stem is sealed.
5. Assemble the shut-off valve and pipe clamp and mount it on the supply line. The inlet tube of the shut-off valve must extend through the rubber washer and 1/8" hole drilled in the line. Tighten the packing nut. Tighten the clamp screws just enough for the rubber gasket to insure watertight seal. Clamping too tightly may crush the copper tubing.

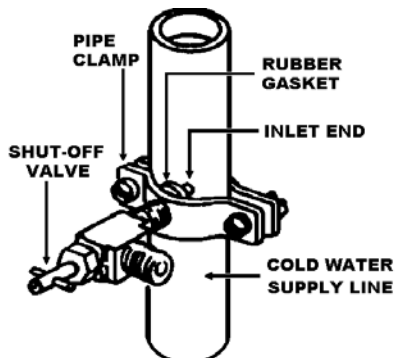

6. Slip the compression nut, and then the sleeve, on the end of the 1/4" tubing. Insert the end of the tube into the outlet end of the shut-off valve as far as it will go, then screw the compression nut onto the shut-off valve enough to get a watertight seal. Place the end in a sink drain or a bucket.

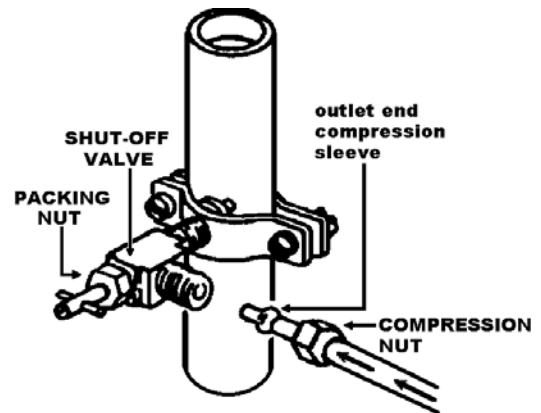

7. Turn on the main water supply. Turn the handle on the shut-off valve counterclockwise to open the valve and flush the tubing until the water runs clear, then close the valve again.
8. Bend the tubing to run it to the installation location. Position the tubing so it can enter the access hole located in the right rear of the icemaker cabinet. The tubing will extend beyond the cabinet front when the cabinet is pushed back into position.

Drain connection requirements

The icemaker has a gravity drain. The ideal installation has a standpipe (1 1/4" minimum) installed directly below the outlet of the drain tube. (See diagram on top of the next page for proper location of the standpipe.)

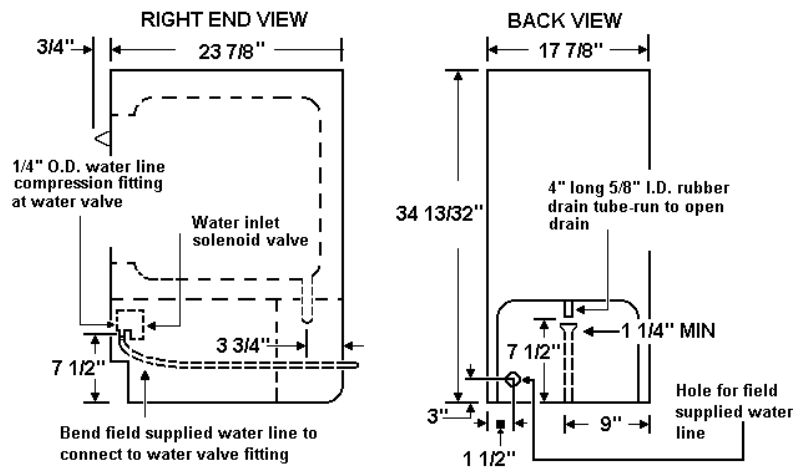

HOW IT WORKS

The pump currently recommended for use with an under counter or free standing icemaker is a pressure activated high speed pump which lift water (from melting ice and fill cycles) to a place where it can be disposed of.

Remember, the drain must run into an open drain standpipe. The drain tube cannot be “sealed” into the standpipe.

Because the drainage water will probably be very cold, it may be desirable to insulate the drain standpipe thoroughly up to the drain inlet to minimize condensation on the drain standpipe.

When a drain connection below the icemaker is not available, a drain pump may be used to lift the water to an available drain.

A drain pump can be installed on the floor directly behind the unit when it is installed. Install the pump with the discharge tube to the rear. Run a 5/8” ID plastic tube from the bin drain directly into the pump as shown below.

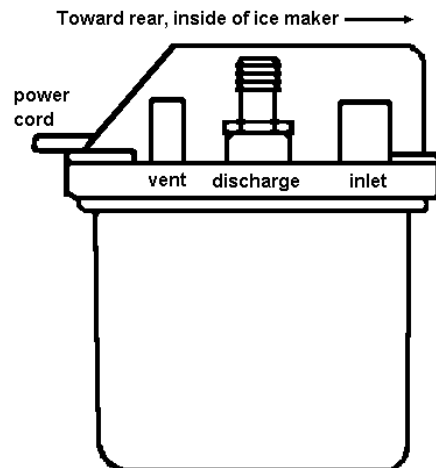
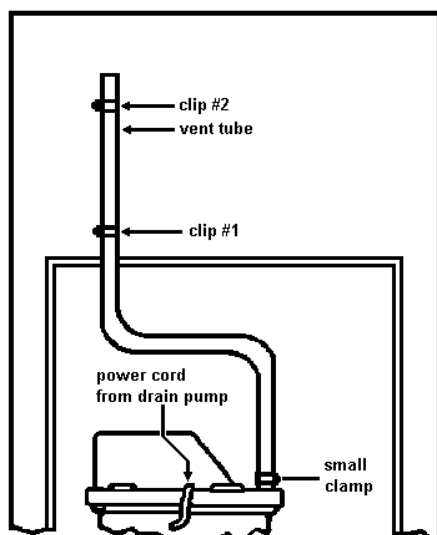

The drain pump installs in the compartment below the icemaker storage bin and operates on 120 volts 60 Hz current. It receives its AC power from a grounded, grounding type wall outlet.

It connects directly to the drain stub of the storage bin and as the sealed chamber of the pump fills, the pressure from the water actuates the pressure switch and causes the pump to run and pump water from the chamber.

The water exits through the discharge port and is prevented from re-interring the chamber be a check valve.

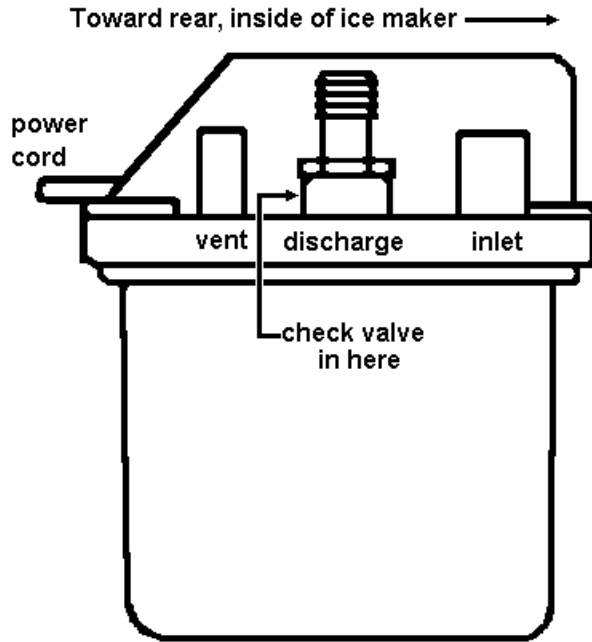

The drain pump has a check valve located in the discharge outlet valve.

The important thing to remember is that the pump is a sealed unit and depends on the weight of the water accumulating in the drain from the storage bin to activate it---so, make sure that the pump chamber and lid are sealed to prevent water leakage, and that all hoses are well connected and water tight.

When pump is in harvest, the electrical circuit bypasses the pump pressure switch, and pump runs continuously.

At all other times, regardless of any other switch setting or condition, the pump is on line and will run when the pressure switch closes.

If the pump should fail to run when the pressure switch closes, it interrupts the circuit to the fill valve so that no additional water can enter. It also interrupts the circuit to the hot gas defrost solenoid.

Place the icemaker electrical power cord into the pump outlet. Plug the power cord of the pump into a properly grounded, grounding type outlet.

Sump pumps may be used with the icemaker. These pumps are usually located near the available drain. Run a 5/8" ID plastic tube from the unit's bin drain to the pump, and a plastic hose from the discharge outlet of the pump into the available drain. If the pump does not have a check valve on the discharge outlet valve, one should be installed on the outlet tube. The sump pump will be plugged directly into an available power supply near the drain. A pressure switch within the pump will operate the pump as needed, independently of the icemaker operation.

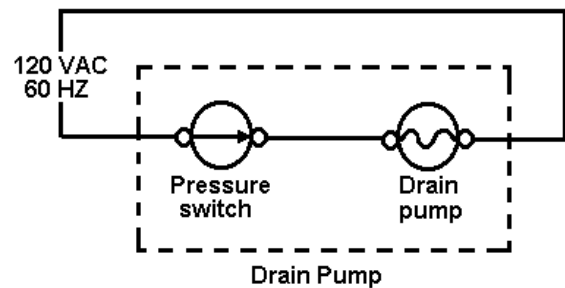

Installing the unit

1. Lay the carton on its rear face and break open the bottom flaps.
2. Set the carton upright with all four flaps outward.

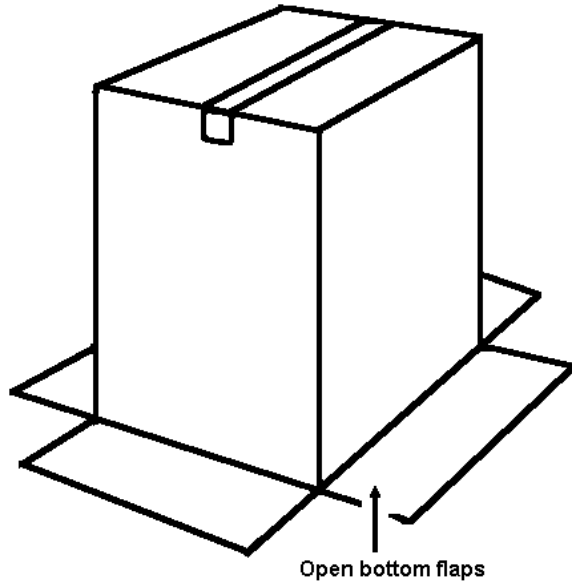

CAUTION

Floor Damage
Slide icemaker onto cardboard / hard Board before moving across floor.

Failure to do so could result in Damage to floor covering.

3. Lift the carton up and off the unit.
4. Remove all of the packing tape and packaging material from the outside and inside of the cabinet.
5. Remove the lower panel and grille by removing the two securing screws at the bottom of the grille, and pulling the lower panel assembly down and outward.

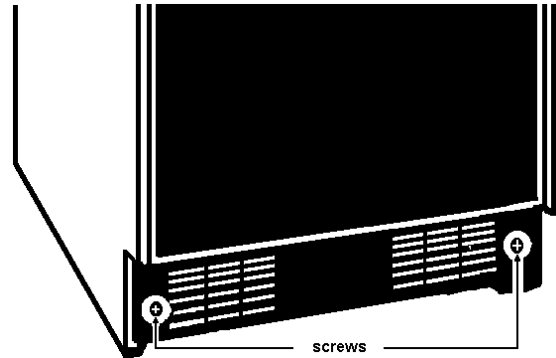

6. Reach into the unit compartment and turn the fan by hand to make certain it moves freely.
7. Inside the bin, loosen the thumb screws holding the cutter grid and the water reservoir pan until they are just "thumb tight".

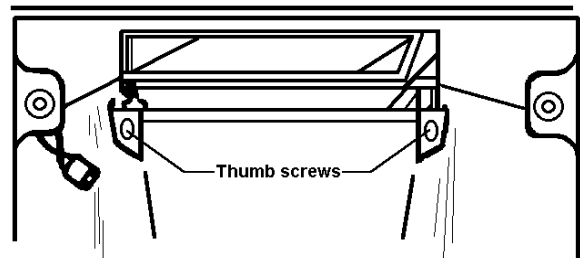
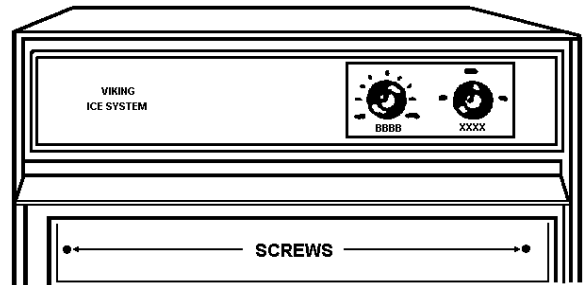

8. Carefully move the icemaker into the installation location, pulling the water supply line through the hole in the rear. The water line will project through the front of the unit after the icemaker is pushed back into position.

If the icemaker is to be installed under a countertop, do not push the unit all the way back until it is leveled from side to side.

9. Check that the unit is level side to side by placing a level across the top of the cabinet. Then check that the unit is level from front to back. If the unit is installed under a countertop, the front to back leveling should be checked after the unit is pushed back into its final position. Place a level along either side rail inside the unit compartment.
10. If necessary, the icemaker should be shimmed so that it is solid as well as level. Use a hard, permanent material, such as masonite, for shims.
11. After the icemaker is in place, bend the water supply tubing to meet the connection at the water inlet valve. (it may be necessary to trim off some of the excessive length of tubing.) Use the garden hose threaded compression fitting supplied with the icemaker to connect the water supply line to the unit.

After completing the water line connection, open the water supply line valve and check for water tight seals along the supply line.

Also, make sure the tubing inside the unit compartment does not touch any other component in the compartment, to prevent rattles.

12. Local sanitation codes may require that the icemaker cabinet is sealed to the floor with an approved caulking compound.
13. If the front panels are not going to be changed (See below), replace the lower panel and grille assembly.

Thermostat Calibration

If the icemaker is installed in a location over 2000 feet above sea level, the bin and evaporator thermostats must be adjusted to compensate for the altitude.

On the control panel (under the escutcheon), on some models of icemakers, there will be access holes to the altitude adjustment control for each thermostat, and a label with adjustment instructions on the front of the control panel..

On other units, it will be necessary to remove the thermostats to make the adjustments and to read the instructions stamped onto the thermostat itself.

See page 26 for instructions on how to remove the escutcheon, and control panel and thermostats, if necessary.

MAKE ALTITUDE ADJUSTMENTS ON THE THERMOSTATS ONLY TO CORRECT FOR PROPER ALTITUDE OF INSTALLATION, DO NOT MAKE ALTITUDE ADJUSTMENTS OF THE THERMOSTATS TO CORRECT OTHER OPERATIONAL PROBLEMS WITH THE UNIT.

Water Deflector Installation

If the icemaker is installed aboard a ship or a recreational vehicle where it will be operated while the RV is moving, it is necessary to purchase and install a Water Deflector Kit from your parts distributor. The water deflector hangs in front of the evaporator and keeps water flowing over the evaporator from spilling into the storage bin area.



Electrical Shock Hazard

Do not let electrical wiring and components contact the drain hose or any plumbing material.

Failure to follow these instructions could result in fire, electrical shock or other personal injuries.

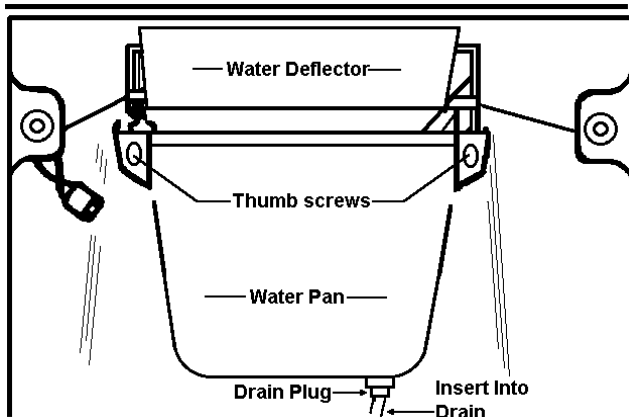

Starting up the unit

Before using the icemaker, the consumer should wash out the bin area with a baking soda solution (2 tablespoons of soda to a quart of warm water). Then rinse thoroughly.

Make sure the water supply and electric power is turned on.

Allow the icemaker to run 3 hours before expecting ice and 24 hours before trying to set the thickness control.

The icemaker has been factory set to produce ice approximately 1/2" thick while operating in a room ambient temperature of 70°F (21°C). operation in different room ambient temperatures may require adjusting the control toward the thick or thin settings.

The best and most efficient operation of the unit will be obtained when the ice is manufactured between 1/2" and 5/8" thick.

Normal Consumer Maintenance

The minerals rejected from circulating water during the ice making cycle may eventually form a hard scaly deposit in the water system, inhibiting the release of the ice slab from the evaporator.

It is therefore necessary to periodically clean the unit's water system to remove the mineral scale build-up. The frequency of cleaning will depend on the hardness of the water.

To Clean the Water System

1. Set the service control to the "OFF" position.
2. Open the bin door and remove the 2 thumb screws that secure the ice cutter grid. Slide out the cutter grid, and unplug the grid wiring harness.

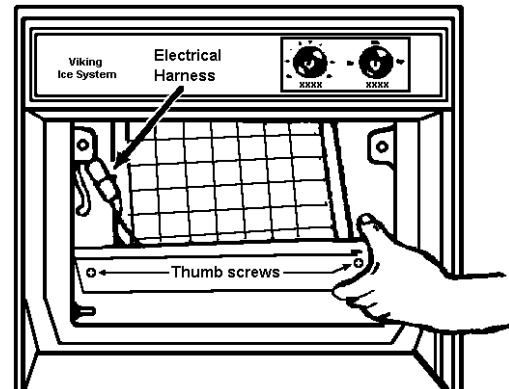

If there is ice on the cutter grid, melt it off under running warm water in sink. DO NOT try to pick the ice off the grid wires.

CAUTION

Any ice on the grid should be melted under running warm water. Attempting to pick the ice slab off the grid may stretch and damage the grid wires.

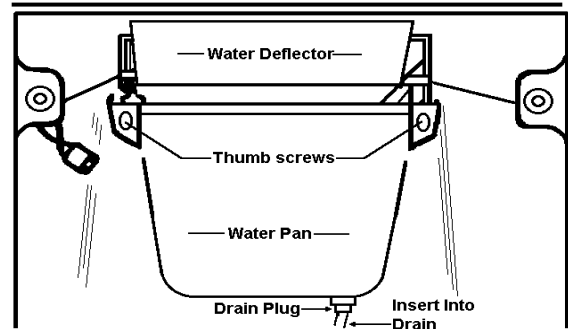

3. Remove all of the ice from the bin and from off the evaporator freezing plate.
4. Remove the drain plug on the bottom of the water reservoir pan. When the pan is completely drained, replace the drain plug.

5. Pour ½ gallon (approx. 2 liters) of hot tap water into the water reservoir pan. Turn the service control switch to the “CLEAN” position. Allow the hot water to circulate for 5 minutes.
6. While the hot water is circulating, prepare the icemaker cleaning solution.

Always wear gloves while handling icemaker cleaner.

Preparing cleaning solution from acid crystals.

Citric acid crystals are available from most pharmacies and some plumbing supply houses. Mix 6 oz. (170gm) of powdered citric acid crystals into ½ gallon of hot water.

Note: Always mix crystals into the entire ½ gal. of water.

WHEN USING POWDERED ACID CRYSTALS TO MAKE A CLEANING SOLUTION, USE ONLY CITRIC ACID. DO NOT USE POWDERED PHOSPHORIC ACID.

Using a commercially prepared cleaning solution

Commercially prepared liquid ice machine cleaning solutions are available from refrigeration and plumbing supply houses.

WHEN USING A COMMERCIALY PREPARED LIQUID CLEANING SOLUTION USE ONLY A CITRIC ACID BASED SOLUTION, OR A COMBINATION OF CITRIC ACID AND PHOSPHORIC ACID BASED SOLUTION. DO NOT USE MURIATIC ACID OR ANY OTHER ACID NOT APPROVED FOR USE IN A FOOD MACHINE.

Carefully follow the instructions on the bottle of icemaker cleaner to prepare ½ gallon (approx. 2 liters) of cleaning solution.

WARNING

Personal Injury Hazard

Most ice machine cleaners are caustic or Phosphoric acid which can cause irritation even after dilution. In case of contact with eyes, flush eyes thoroughly with fresh water and contact a physician immediately. In case of contact with skin, rinse well with water. If swallowed, give large amounts of water and contact a physician immediately. Do not induce vomiting. KEEP OUT OF REACH OF CHILDREN.

7. Turn the service control switch to the “OFF” position. Drain the hot tap water from the water reservoir pan. Replace the drain plug when the pan is empty.
8. Turn the service control switch to the “CLEAN” position. Carefully pour the entire ½ gal. of cleaning solution into the water reservoir pan.
9. Allow the cleaning solution to circulate until the mineral build-up on the evaporator freezing plate has dissolved. (If at the end of 30 min. the build-up has not dissolved, turn the service switch to the “OFF” position, and carefully drain out the cleaning solution. Mix another ½ gal. of solution and add as before.) repeat the cleaning cycle as necessary until all of the mineral build-up has been dissolved.
10. While the cleaning solution is circulating, clean the cutter grid by dipping it into a pan of prepared cleaning solution. (After allowing the grid to soak for approximately 15 min., use a hard bristled brush to scrub the wire connectors and insulators around the edge of the grid.) rinse the grid under running water in the sink.
11. Clean the scale off of the side flanges of the evaporator freezing plate with a plastic scrubber dipped into the prepared cleaning solution. Always scrub in the direction of water flow (from front to back on the side of the plate.)
12. After draining out the cleaning solution from the water reservoir pan, add ½ gal. of fresh water and allow it to circulate for 5 minutes. Drain, and repeat the rinsing process at least one more time.

13. Wash out the bin and the inside of the bin door with a soft cloth and a warm water and baking soda solution.
14. Clean the exterior enamel surfaces and the gaskets around the door with warm water and a mild soap or detergent. Rinse and dry after washing. **DO NOT** use a harsh or abrasive cleaner on the exterior surfaces. Use of a good household appliance cleaner and wax will help protect the exterior finish of the icemaker.
15. Replace the cutter grid. And make certain the drain plug has been replaced in the bottom of the water reservoir pan. Turn the service control switch to the "ON" position and begin normal operation of the icemaker.

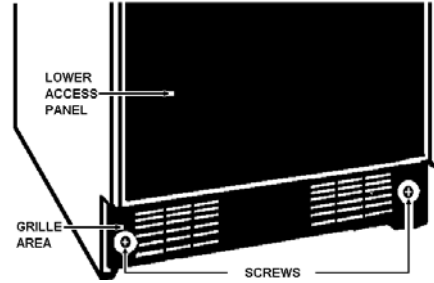

3. Using a soft brush or a round dust brush attachment on a vacuum cleaner, remove lint and dirt from the condenser fins.

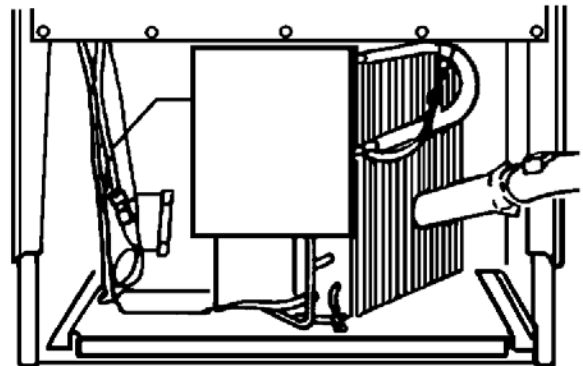

WARNING

Personal Injury Hazard: Be sure the icemaker is OFF and disconnected from the main power supply. Condenser fan rotation, sharp condenser fins and hot tubing could cause personal injury.

It is also necessary to periodically clean the air cooled condenser to ensure efficient operation of the icemaker.

To clean the condenser

1. Make sure that power is disrupted to the icemaker.
2. Remove the two (2) screws at the bottom of the grille and remove the grille and lower panel assembly.

WARNING

Personal Injury Hazard: **DO NOT** operate icemaker with the lower access panel or control panel removed. Personal injury could result.

CAUTION

Condenser fins can bend easily. Use care when vacuuming the condenser to keep from bending the fins.

4. Use a vacuum cleaner to remove dirt from the bottom of the unit compartment.
5. Replace the lower panel and grille assembly. Reconnect the power supply.

MAKE SURE THE INSTALLATION AND OPERATION OF THE ICEMAKER CONFORMS TO ALL APPLICABLE CODES.

OPERATION

It is important to understand how the ice maker operates in order to properly service a unit and properly diagnose problems and consumer complaints.

Operating Systems

There are three operating systems in the icemaker.

Refrigeration System

The refrigeration system in the icemaker is very similar to the system used in other refrigeration appliances such as a refrigerator or freezer.

There are, however, two very important additions to the refrigeration system in the icemaker.

- Hot Gas Valve
- Condenser Accumulating Tube

The refrigerant used in the sealed system is R-134-A. The refrigerant must NEVER be released into the atmosphere.

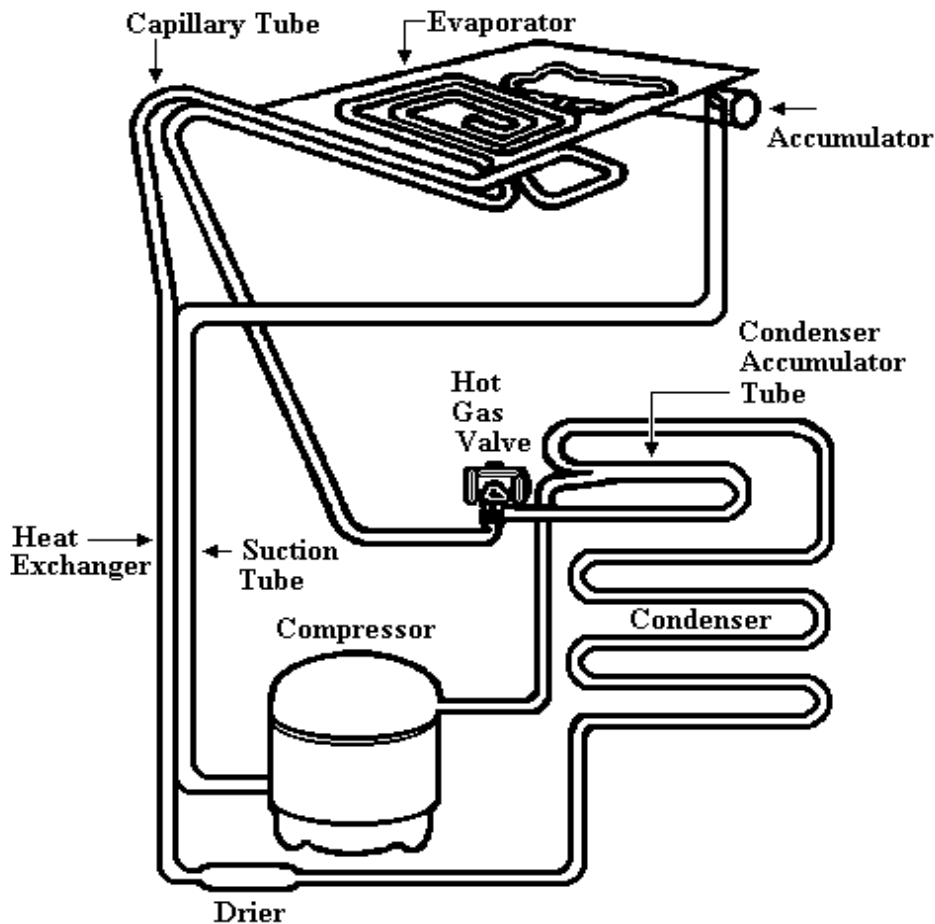

WATER SYSTEM

The water system provides the fresh water necessary for ice production, recycling this water as ice is produced. The water system also flushes away rejected minerals and contaminants, circulates cleaning solution during the CLEAN CYCLE, and provides a means of drainage.

The hardness of water supplied to the icemaker will not only affect the quality of the ice produced, but may also affect the operation of the water system. (See chart of minerals often found in water along with their effects on ice making on page 39).

A water softener or polyphosphate feeder will not cure all problem associated with hard water, but they can be used to reduce built-up in the icemaker.

Note: Some polyphosphates feeder will cause a slime build-up in the water system when the water supply has a low mineral content.

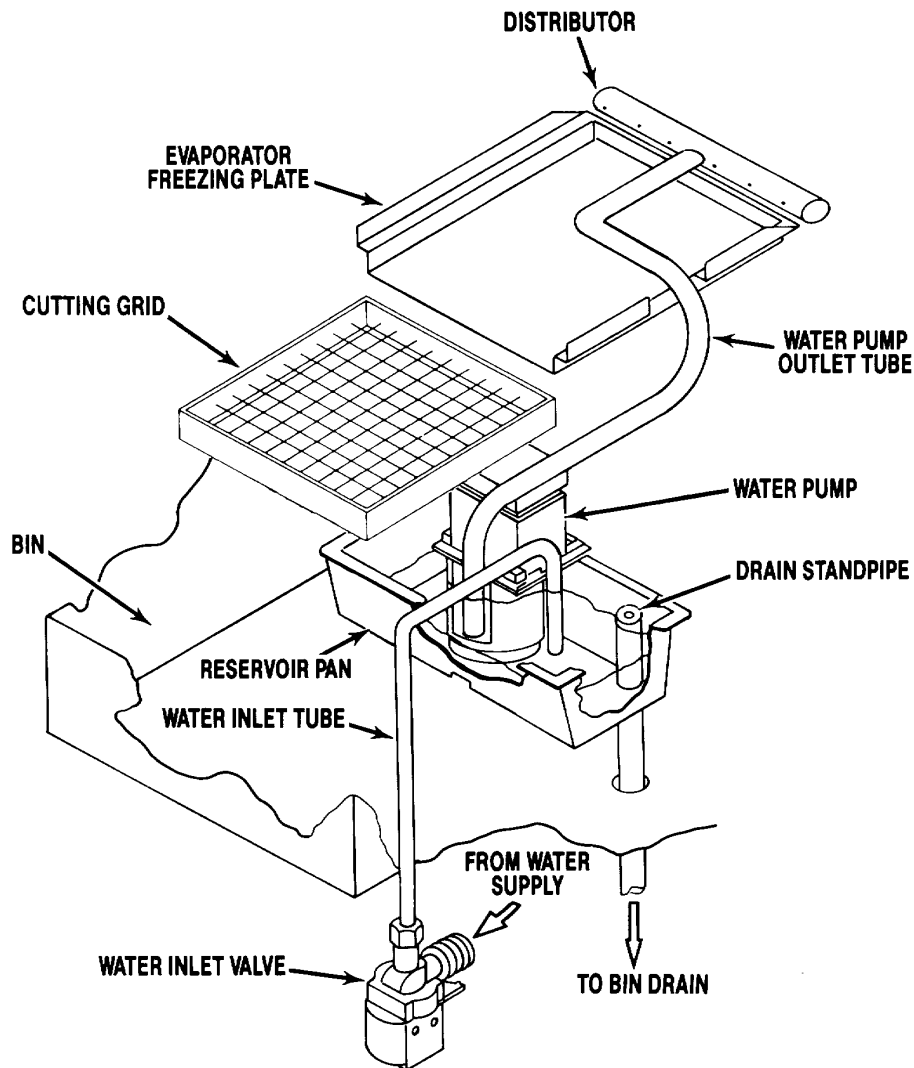

Electrical System

The unit's electrical system provides for refrigeration and water system to operate, and controls the operational cycling of the icemaker.

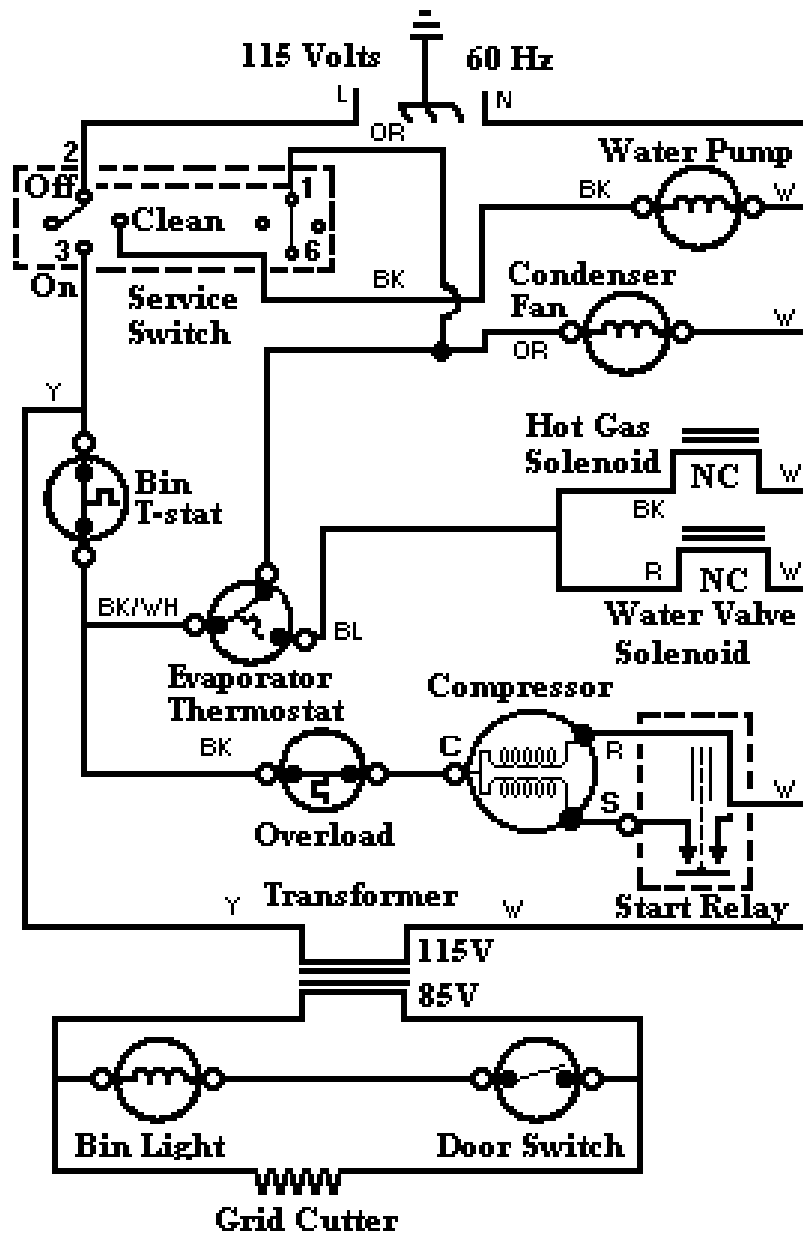

Unit shown with gravity drain: Service switch in "OFF" position: Bin not full of ice.

Component wiring diagram (block) with point to point connection and wire colors.

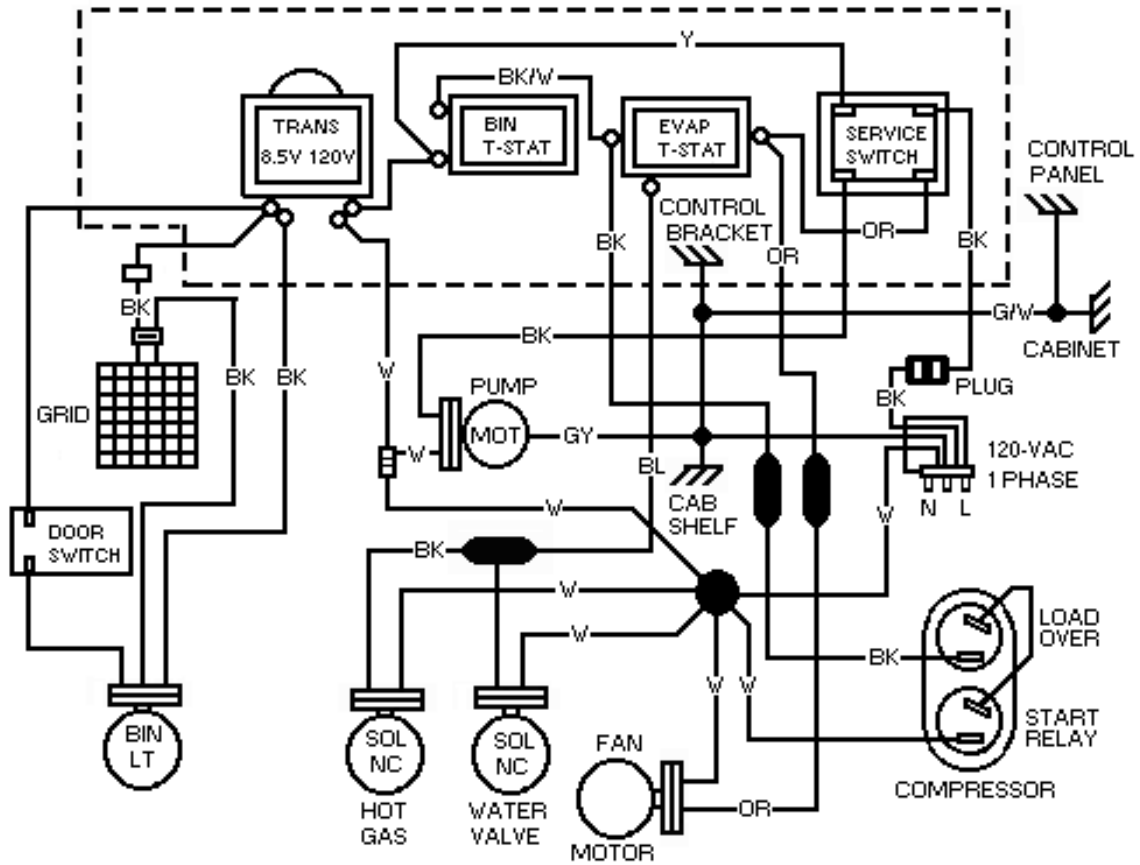

| COLOR CHART | |
|-------------|--------------------|
| R | RED |
| BK | BLACK |
| BL | BLUE |
| W | WHITE |
| Y | YELLOW |
| OR | ORANGE |
| BK/W | BLACK/WHITE TRACE |
| G/Y | GREEN/YELLOW TRACE |

Operational Cycle

There are three operational cycles of the icemaker:

- ICE MAKER cycle
- HARVEST cycle
- CLEAN cycle

In addition, there are two operational OFF cycles of the icemaker.

- OFF cycle when bin is full of ice and service control switch is turned to the "ON" position.
- OFF cycle when the service control switch is turned to "OFF" position while power is still supplied to the unit.

When the icemaker's **service switch** is in the "ON" position, and the bin is not full of ice, the evaporator thermostat determines whether the unit will be in the ICE MAKING cycle or the HARVEST cycle. The **thickness control knob** adjusts the evaporator thermostat to sense different temperatures on the evaporator freezing plate, which causes a different thickness of ice.

ICE MAKING CYCLE

In the electrical system, power is supplied through the service control switch.

- To the transformer (and cutter grid, and the bin light through the door switch.)
- Through the bin thermostat to the compressor.

Power is supplied through the evaporator thermostat to :

- The condenser fan
- The water pump

In the refrigeration system, the hot gas refrigerant, under high pressure, is forced through the condenser where heat is removed. The refrigerant is condensed to a liquid, and flows through the drier and capillary tube into the evaporator. Under low pressure in the evaporator, the liquid refrigerant absorbs heat from the water flowing over the evaporator. The refrigerant evaporates into a gas and passed into the accumulator. As a low pressure gas, the refrigerant flows back through the heat exchanger and suction tube to the compressor.

During ICE MAKING cycle, some of the hot gas that is in the condenser accumulator tube condenses to liquid and remains in the accumulating tube.

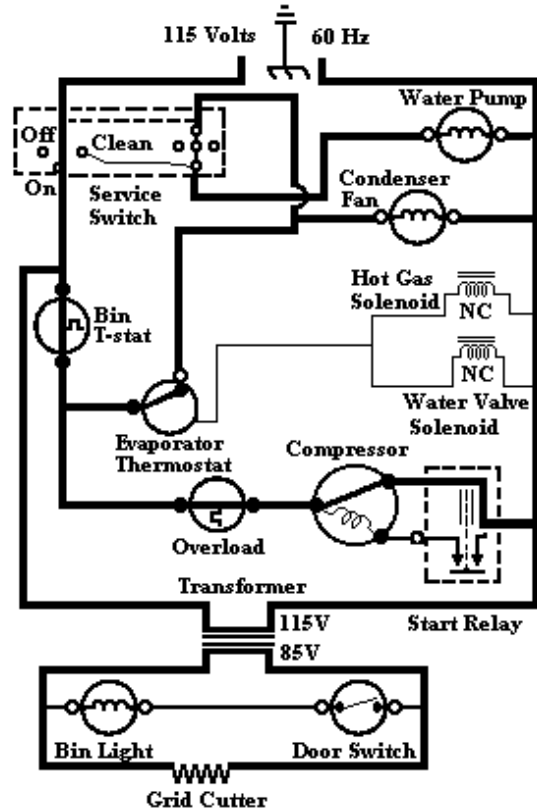

ICE MAKING CYCLE

During the later stages of ICE MAKING cycle, as the ice slab forms on the evaporator freezing plate, some of the refrigerant passing through the evaporator will not evaporate into a gas, but will remain a liquid. This liquid refrigerant will settle in the accumulator while the refrigerant vapor will be sucked off through the suction tube at the top of the accumulator. This accumulated liquid refrigerant will be evaporated eventually by the warmed refrigerant gas passing through the accumulator during the HARVEST cycle and during the beginning of the next ICE MAKING cycle

NOTE: It is very important the accumulator is not tilted out of a horizontal position.

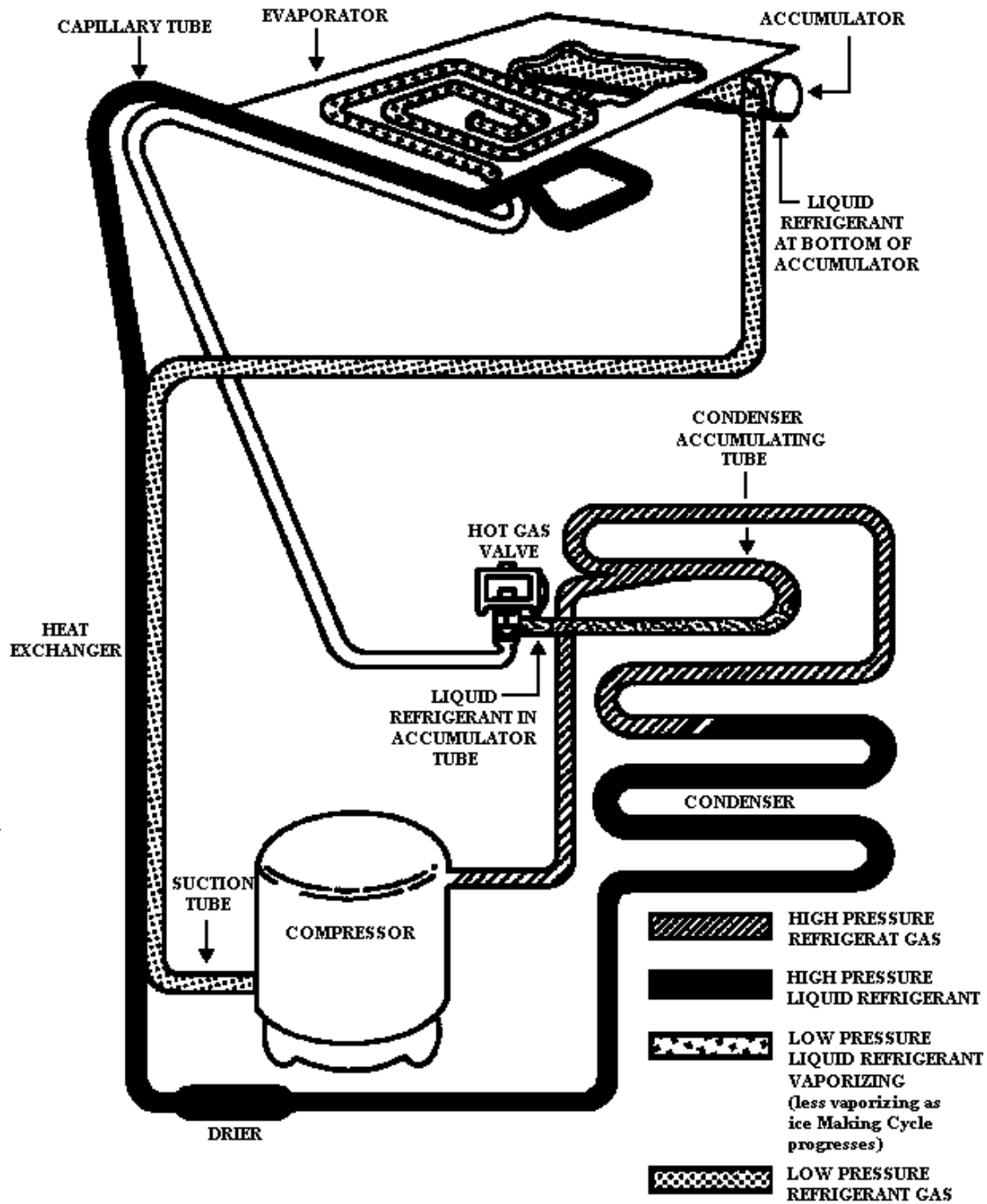

In the water system, the water pump moves the water from the reservoir pan up to the distributor, where it flows out over the evaporator freezing plate.

Water that does not freeze on the evaporator plate runs off the front edge and falls back into the reservoir, where it is recycled back to the distributor.

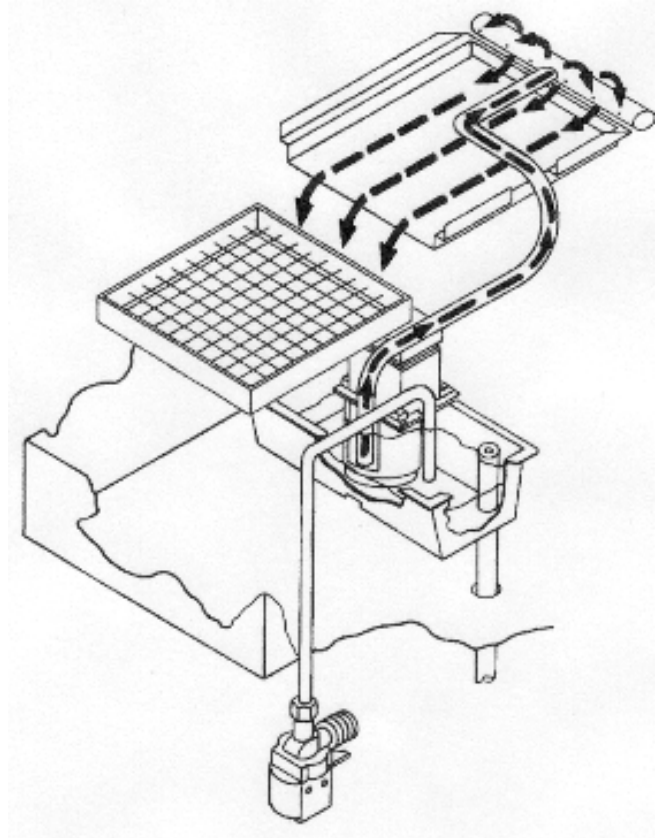

As the ice slab forms, the minerals in the water are on the surface of the ice. The water flowing over the top of the ice slab washes these minerals back into the water reservoir pan. The water continues to recycle until the ice slab reaches the desired thickness.

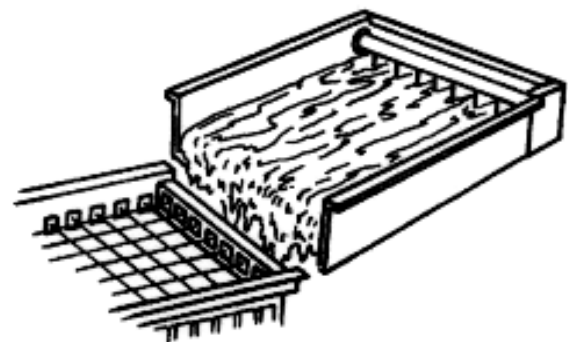

Harvest Cycle

In the electrical system, when the set temperature of the evaporator thermostat is reached, the evaporator thermostat terminates power to the fan and water pump, and supplies power to the hot gas valve solenoid and the water fill valve solenoid.

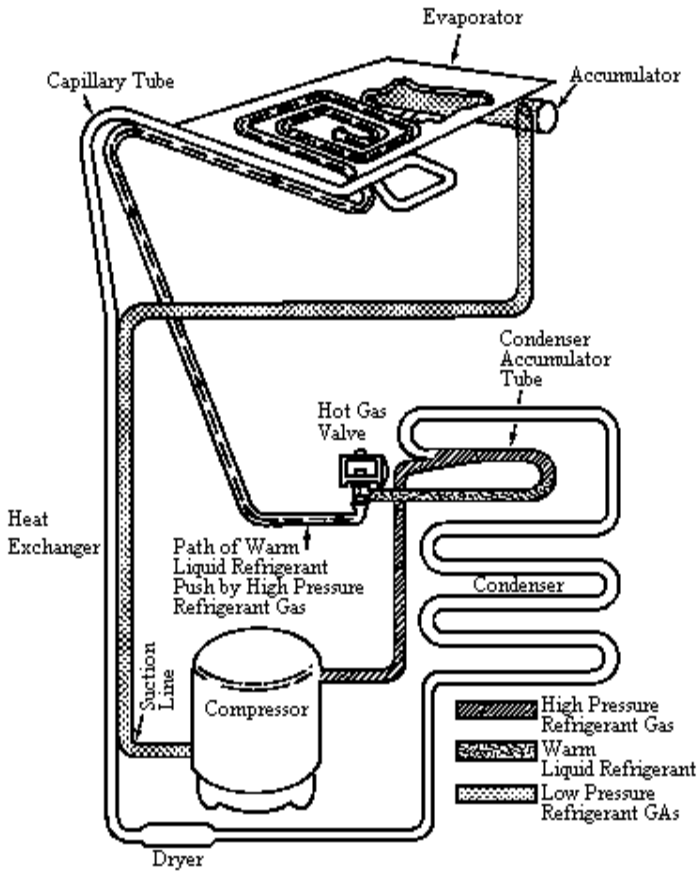
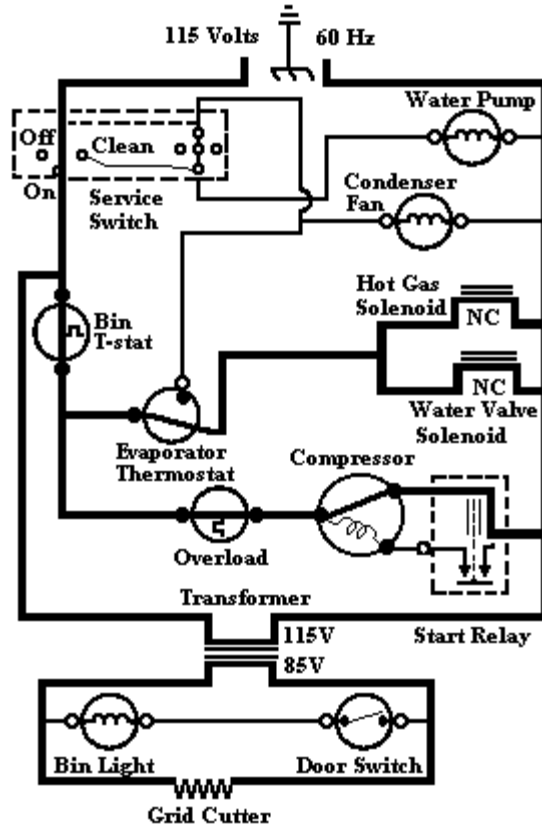

In the refrigeration system, the hot gas valve opens, allowing high pressure refrigerant gas to bypass the condenser accumulating tube. The hot gas pushes the liquid refrigerant that has accumulated in the accumulator tube up into the evaporator plate so the ice slab releases quickly and evenly.

The ice slab, when released, slides off of the evaporator plate onto the cutter grid, where it begins to be divided into individual cubes that fall into the bin.

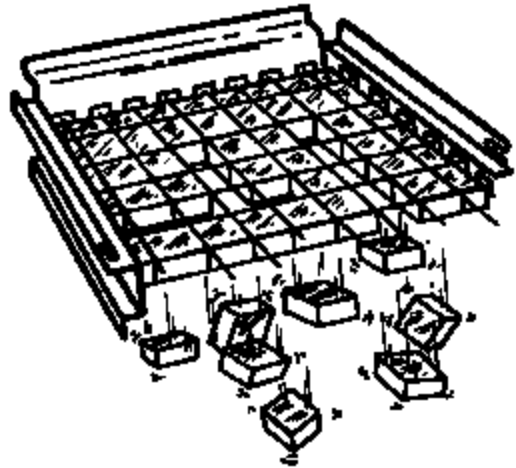
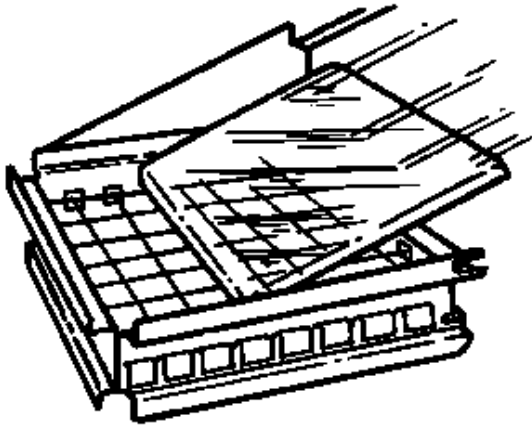

In the water system the water valve opens allowing water to flow into the water reservoir pan. As the reservoir fills, the mineral-laden water from the previous ICE MAKING cycle is flushed out to the drain.

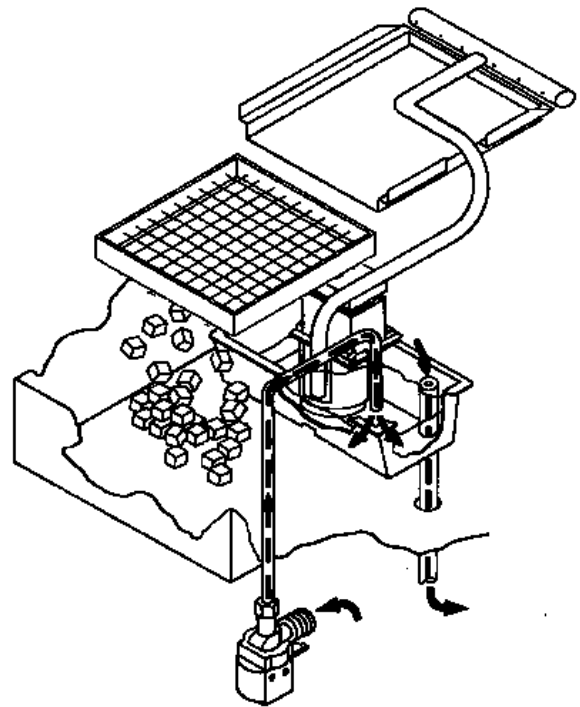

When the evaporator temperature rises, because of the hot gas flow and because the ice slab has slid off, the evaporator thermostat switches the unit to the ICE MAKING cycle. This cycling, between the ICE MAKING cycle and the HARVEST cycle, continues until the ice bin is full.

OFF Cycle when the bin is full of ice and the service control switch is in the “ON” position.

In the electrical system, when the bin thermostat senses the bin is full of ice, power is cut off to all of the electrical system except for the transformer (and to the cutting grid, and bin light through the door switch.)

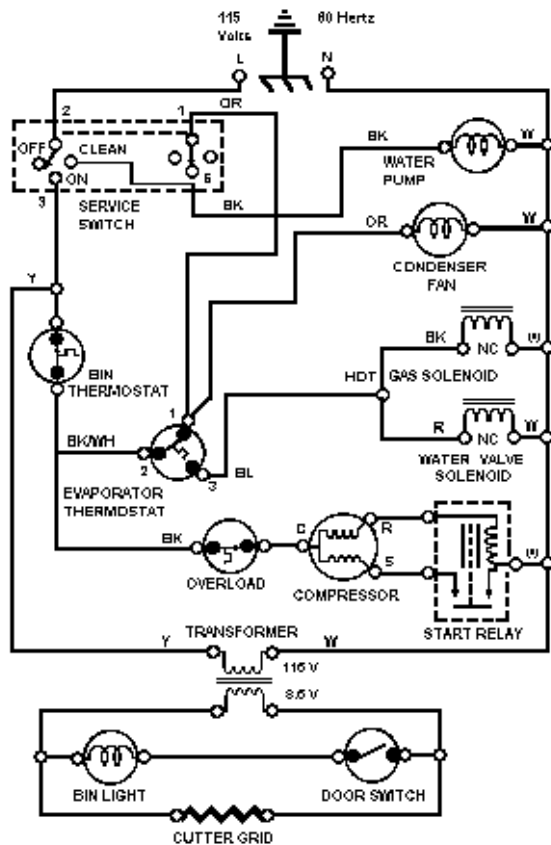
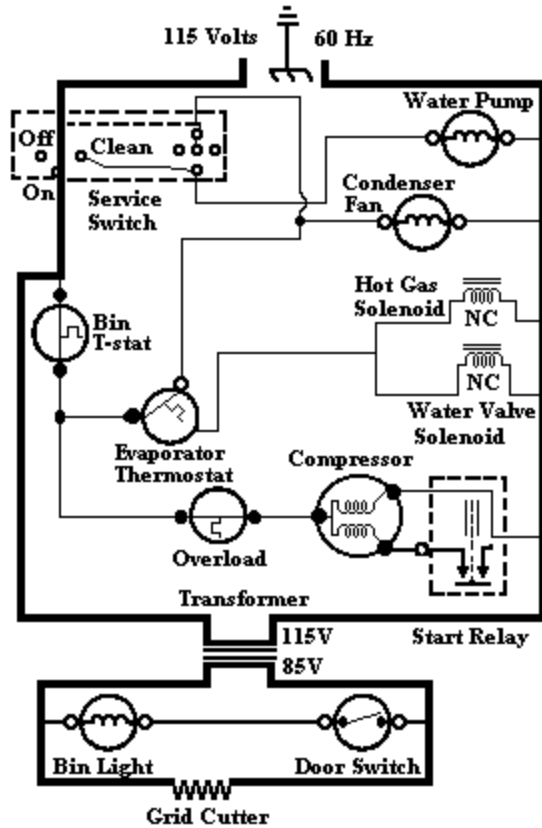

OFF Cycle when the service control switch is in the "OFF" position but power is still supplied to the unit.

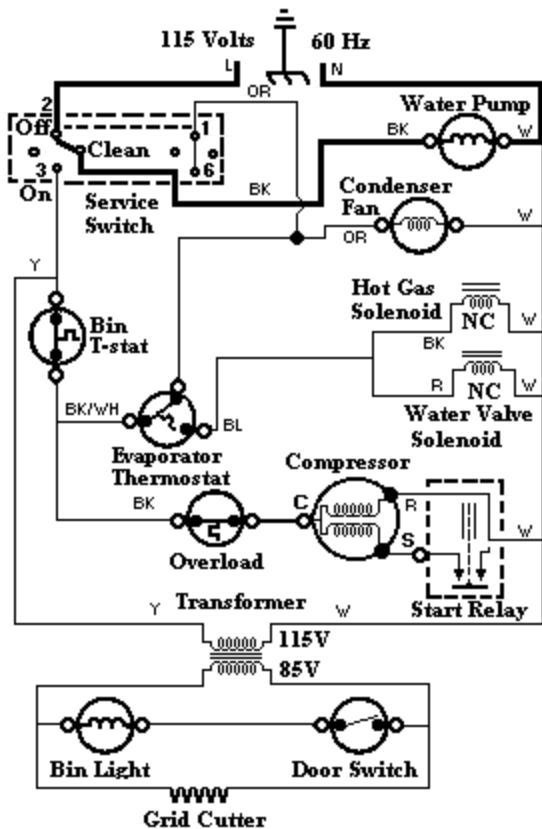

- The water valve is opened (allowing water to enter the unit) only during the HARVEST cycle.
- The condenser fan runs only during the ICE MAKING cycle.

CLEAN Cycle

In the electrical system, power is supplied to the water pump through the service control switch.

The refrigeration system does not operate during the CLEAN cycle.

In the water system, water pump circulates the cleaning solution that has been added to the reservoir up to the distributor, across the evaporator, and back into the reservoir where it is re-circulated while the service control switch is in the "CLEAN" position.

- The compressor runs continuously during the ICE MAKING and HARVEST cycle.
- The water pump runs continuously during the ICE MAKING and CLEAN cycle.
- The cutter grid (and the bin light through the door switch) is energized during the ICE MAKING and HARVEST cycle, but not during the CLEAN cycle or when the service switch is in the "OFF" position.

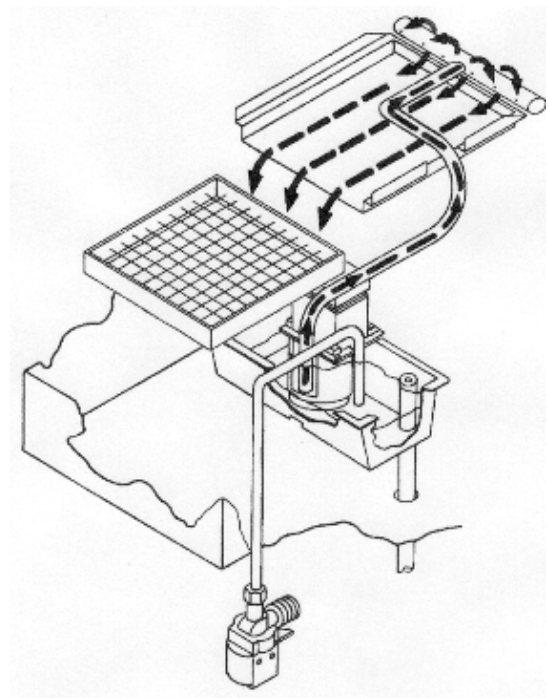

COMPONENT LAYOUT

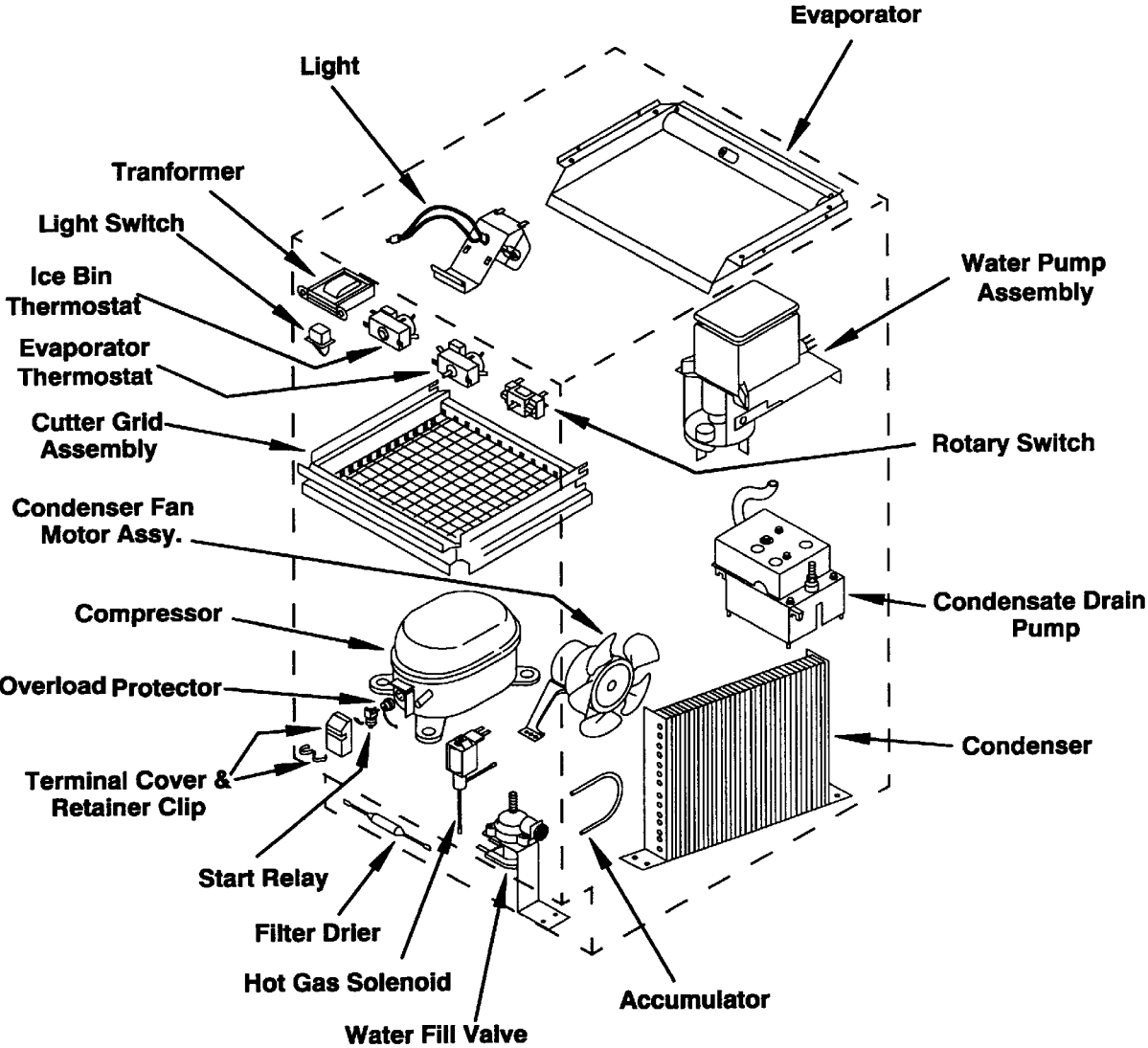

COMPONENTS IN THE CONTROL PANEL AREA

If the icemaker has been installed under a counter top, it is usually not necessary to pull out the unit for servicing.

Before removing any component for replacement or testing, make sure power has been disrupted to the unit.

WARNING

Electrical Shock Hazard: Disconnect power supply—Failure to do so could result in electrical or personal injury.

NOTE: If a component in the refrigeration sealed system must be replaced, it is necessary to use an approved method of accessing the system.

ALL AUTHORIZED SERVICERS MUST UTILIZE A CFC RECOVERY AND HANDLING PROGRAM THAT MEETS ALL THE REQUIREMENTS OF LOCAL, STATE AND FEDERAL LAWS AND REGULATIONS.

The service control switch, the evaporator thermostat control, the bin thermostat control, and the transformer are located behind the control panel. They are all secured to the control panel with screws that are on the front of the control panel.

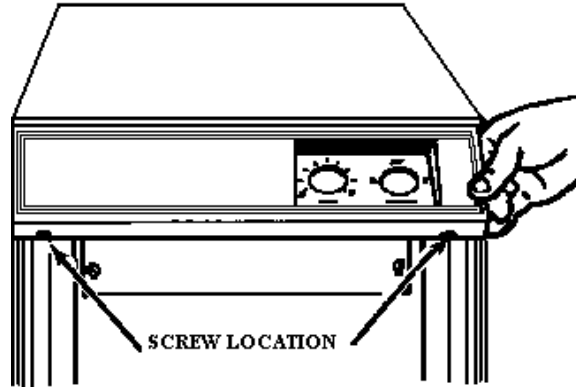

To remove the control panel:

1. Remove the two (2) screws under the control panel.
2. Remove the two (2) control knobs
3. Pull off the escutcheon.
4. If present, remove the two (2) wire leads to the door switch.
5. Remove the two (2) screws that secure the control panel to the cabinet.
6. Carefully pull the control panel down, and tilt outward.

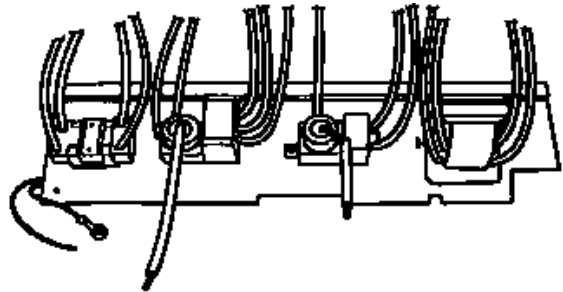

Service Control Switch

- 3-position switch
- Manually operated

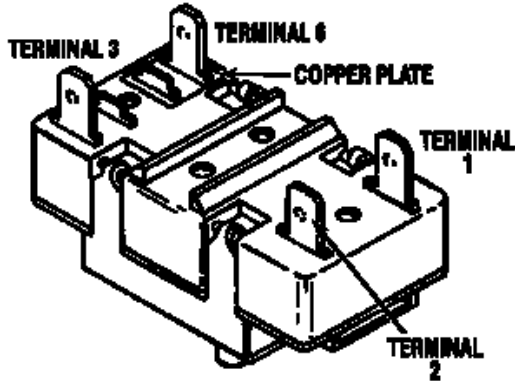

To Test:

1. Remove the wire leads.
2. Use an ohmmeter set the Rx1 scale.
3. With switch in the "ON" position, check across terminals.

| | | | |
|----------|---|----------|---|
| 2 | 3 | 1 | 6 |
| X | | X | |

X -- closed circuit

4. With switch in the "CLEAN" position, check across terminals.

| | | | |
|----------|---|----------|---|
| 2 | 6 | 1 | 3 |
| X | | O | |

X -- closed circuit
O -- open circuit

Evaporator Thermostat

- In the warm position, cuts in at $38^{\circ}\text{F} \pm 2^{\circ}\text{F}$, cuts out $10.5^{\circ}\text{F} \pm 4^{\circ}\text{F}$.
- In the cold position, cuts in at $38^{\circ}\text{F} \pm 2^{\circ}\text{F}$, cuts out at $3^{\circ}\text{F} \pm 2.5^{\circ}\text{F}$.
- Adjustable for altitude correction.

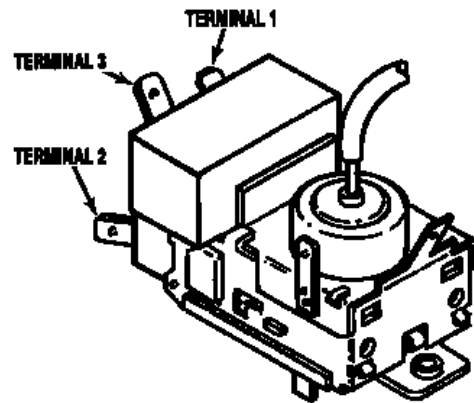

To Test.

Method 1

1. Remove wire leads.
2. Use an ohmmeter set on the Rx1 scale.
3. Feel the evaporator freezing plate. Then check across the terminals.

If the evaporator is cold:

| | | | |
|----------|---|----------|---|
| 2 | 3 | 1 | 2 |
| X | | O | |

X -- closed circuit
O -- open circuit

If the evaporator is warm:

| | | | |
|----------|---|----------|---|
| 2 | 3 | 1 | 2 |
| O | | X | |

X -- closed circuit
O -- open circuit

Method 2

1. Remove wire lead from terminal 6 on the service control switch (disabling the water pump).
2. Reassemble the unit.
3. Reconnect the power supply to the unit.
4. Turn the control service switch to the "ON" position.
5. Feel evaporator plate. It should first get cold, then warm.

With the load removed from the evaporator, the evaporator thermostat should cycle into the HARVEST cycle within a matter of minutes.

Bin Thermostat

- Cuts in at $41^{\circ}\text{F} \pm 1.5^{\circ}\text{F}$
Cuts out at $35^{\circ}\text{F} \pm 1.5^{\circ}\text{F}$
- Adjustable for altitude correction.
- Operates automatically

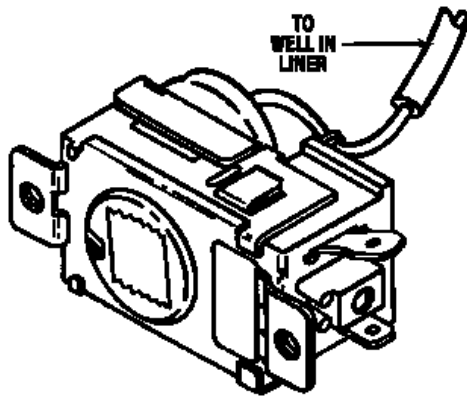

The control capillary bulb of the bin thermostat is located in a well on the left side of the bin liner.

If the bin thermostat is replaced, it is necessary to carefully make a few bends in the capillary tubing before it is threaded into the well, to make certain that the capillary bulb touches the inside of the well.

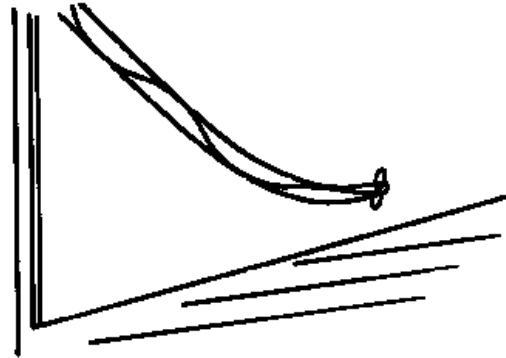

To Test:

1. Remove the wire leads.
2. Use an ohmmeter set on the Rx1 scale
3. Check between terminals.

When the thermostat well is warm.

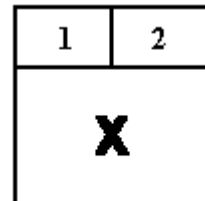

X -- closed circuit

When the thermostat well is cold (hold ice against well):

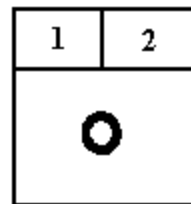

O -- open circuit

Door Light Switch

If present on the unit, the switch is located on the bottom left of the escutcheon.

To Test:

1. Remove the wire leads.
2. Use an ohmmeter set on the Rx1 scale.
3. Test across the terminals.
Then depress the switch.

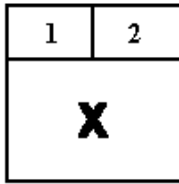

X -- closed circuit

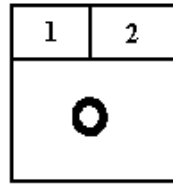

O -- open circuit

COMPONENT ACCESS AND TEST

(Components in the bin area.)

before removing any component for replacement or testing, make sure power has been disrupted to the unit.

| |
|--|
| WARNING |
| Electrical Shock Hazard: Disconnect power supply. Failure to do so could result in electrical shock or personal injury. |

See the notes on page 26 about making repairs on the refrigeration sealed system.

Bin Door

To Remove:

1. Open the door and snap out the ice retainer by flexing it and slipping it off the retaining studs.
2. Remove the screw closest to the door hinge on either the right side or the left side of the door.

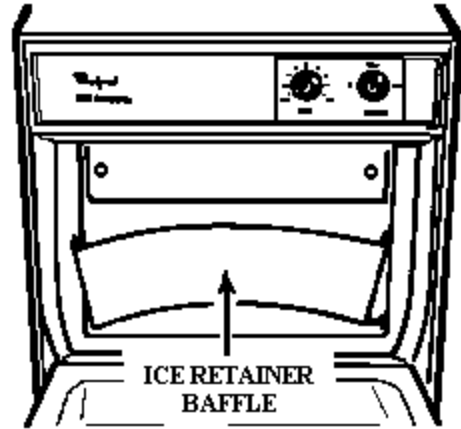

3. Remove the soft white plastic filter plug covering the door hinge pin on the side where the screw was removed.
4. Spread the trim piece free from the door.

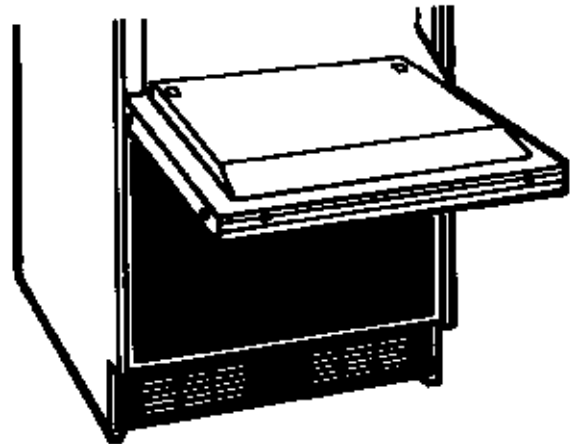

5. Press down on the inside of the door liner next to the hinge, while pulling the door up and off of the hinge pin.
6. Close the door to a 30° open position, and slide the door off of the hinge pin on the other side.

Friction Door Catch

The catch is located on the bottom of the escutcheon. It can often be adjusted by adding washers under the catch. If this does not correct a problem, the catch should be replaced.

Cutter Grid

The cutter grid is an arrangement of incoloy wires supported by a 4-sided frame in a manner to form squares.

The cube cutter grid has wires that produce ice cubes that are 1-1/4 inches by 1-1/4 inches. The wires are arranged in a single circuit.

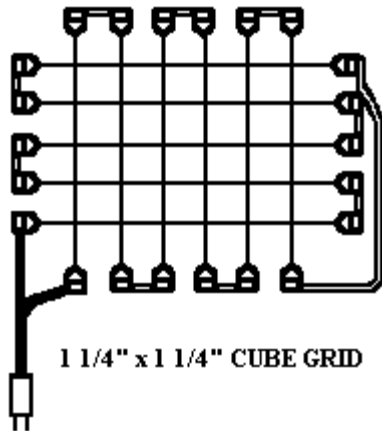

To Check:

Before removing the grid, while the unit is operating, feel the grid wires. They should feel warm to the touch.

1. Remove the two thumb screws that are in front of the cutter grid assembly.
2. Carefully pull the cutter grid out.

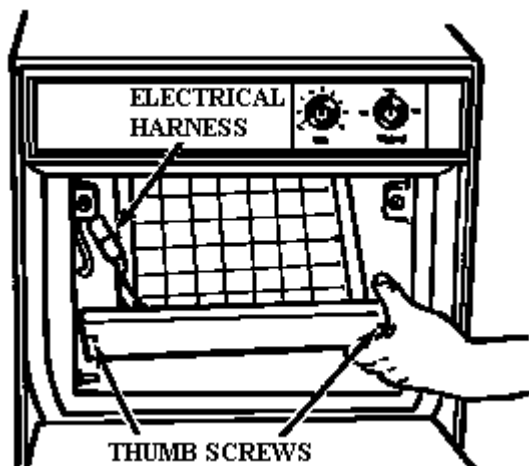

3. Unplug the wiring for the grid from the unit's wiring harness.
4. Visually check the wiring plug. It should be free of mineral build-up. The plastic plug should not show any sign of melting. (Excessive mineral build-up on the plug terminals can cause the plug to overheat.)

If the plug needs to be replaced, replace the entire cutter grid wiring harness.

5. Visually check the grid wires. They should be taut and free of mineral build-up. They should not have black spots where the wires have sagged and touched each other.

If the wires are bad, the entire cutter grid should be replaced.

6. Visually check the terminals, insulators and frame. They should all be free of mineral build-up. The insulators should not have any sign of melting.

If the terminals, insulators or frame are bad, the entire cutter grid should be replaced.

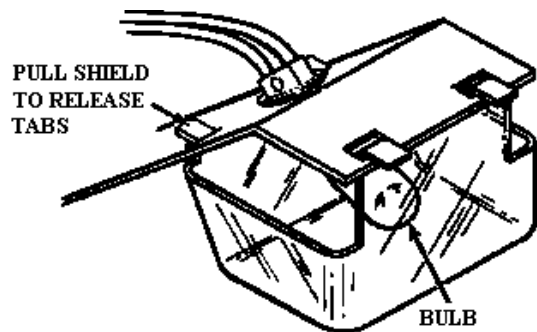

Bin Light

If present, the bin light will be located on the cutter grid assembly.

To replace the light bulb it is necessary to remove the cutter grid assembly and the plastic light shield.

Water Reservoir Pan

The reservoir pan is a plastic tub with a drain hole and an overflow boss to which a drain tube is mounted. The pan is located under the evaporator toward the rear of the inside of the bin.

To Remove:

1. Through not necessary, it is recommended that the bin door be removed for easier access.
2. Remove the two (2) thumb screws at the top of the reservoir pan.
3. Pull out the reservoir pan.

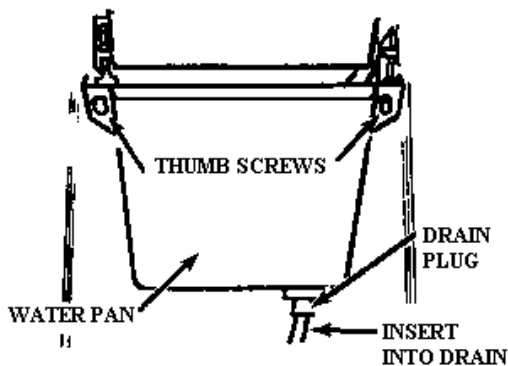

The water reservoir pan should be free of mineral build-up, slime, or mildew.

A water inlet tube runs into the reservoir pan from the water inlet in the unit compartment. The tube must be secured in the notch on the water pump bracket.

A plastic drain tube runs from the overflow boss, or standpipe, on the reservoir pan down through the bin drain.

Water Pump

The water pump is mounted on a bracket on the back wall of the bin and sits in the water reservoir pan.

- Rotates at 3350 RPM's
- An internal overload protector.

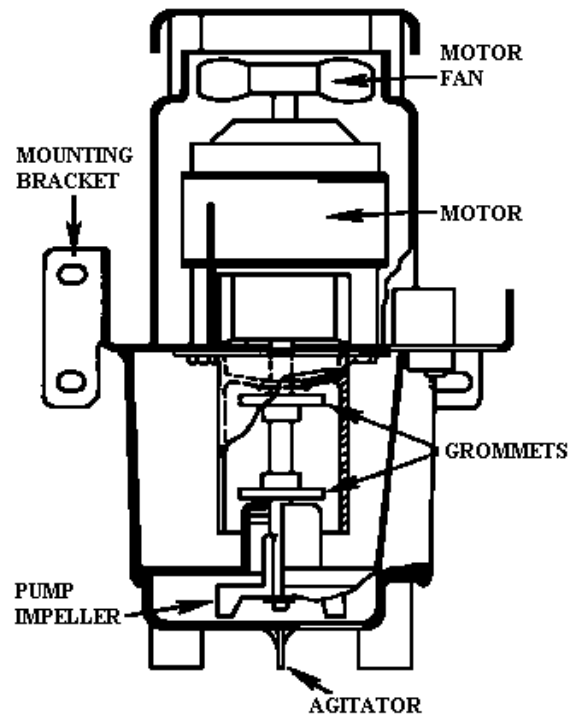

To Remove:

1. Through not necessary, it is recommended that the bin door be removed for easier access.
2. Remove the water reservoir pan.
3. Remove the three (3) screws that notch on the water pump to the mounting bracket on the back bin wall.
4. Snap out the water inlet tube from the notch on the water pump bracket.
5. Remove the water pump outlet tube.
6. Pull the pump forward, out of the socket on the rear bin wall.

To Test:

1. Attach a 120-volt cord to the water pump plug (the top two pins). The pump should operate when power is supplied.
2. Visually check the water pump plug and the socket on the rear bin wall. They should both be free of mineral build-up and any sign of overheating.
3. Check the agitator arm on the bottom of the water pump. It is very important that this arm is not broken off while removing or replacing the pump. The agitator arm breaks up bubbles in the water and prevents an airlock from forming in the impeller area of the pump.

If the agitator arm is broken off, water may be prevented from being pumped up to the distributor. An improperly operating agitator can also cause other ice making problems and low quality ice.

If there are any problems with the pump impeller or the agitator, the entire water pump should be replaced.

Evaporator

The evaporator freezing plate is located directly behind the cutter grid assembly.

The evaporator thermostat capillary bulb is attached to the underneath side of the evaporator plate. At least 8 inches of the thermostat capillary bulb must be bent into an "M" shape and attached tight against the bracket on the bottom side of the evaporator plate.

The capillary tube of the refrigeration sealed system is soldered directly against the front edge of the evaporator plate. This prevents the ice slab from forming a lip over the edge.

At least one inch of the thermostat capillary bulb should be taped to the refrigeration system capillary tube at the front edge of the evaporator plate. This helps to shorten the HARVEST cycle.

The upper surface, and side flanges, of the evaporator freezing plate must be free of mineral build-up, and smooth and even. A nick or scratch could cause the ice slab to hang up during HARVEST cycle.

If the evaporator plate is cleaned with a plastic scrubber, always scrub in the direction of water flow (front to back). If the plate is scratched during cleaning it will not hinder the ice slab from sliding off. The evaporator plate can be dropped for better access.

To Drop:

1. Through not necessary, it is recommended that the bin door be removed for easier access.
2. Remove the cutter grid assembly, water reservoir pan, and water pump.
3. Remove the two (2) thumb screws on the side brackets at the front of the evaporator plate.
4. Carefully pull the evaporator forward and down. Be careful not to bend or kink the attached tubing.

The evaporator can be pulled forward to the front of the bin area when the unit compartment is pulled forward (see page 33).

Side Brackets:

Plastic side brackets are attached to the frame of each side of the evaporator freezing plate. The brackets support the cutter grid, the water reservoir, and the evaporator.

Distributor:

The water distributor is a 5/8 inch diameter molded plastic tube with small holes, and rubber caps in each end. It distributes water evenly over the entire evaporator plate surface.

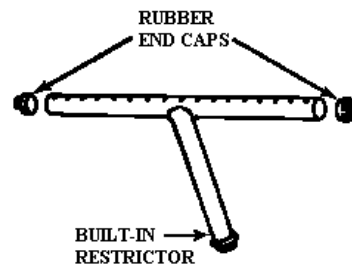

To Remove:

1. Though not necessary, it is recommended that the bin door be removed for easier access.
2. Remove the cutter grid assembly, water reservoir pan, and water pump.
3. Drop the evaporator.
4. Disconnect the water tube that came from the water pump.
5. Pull the distributor out.

The rubber end caps can be removed and the distributor cleaned with a small brush and a mild detergent solution. Each of the small holes in the distributor must be unrestricted.

There is a build-in water restrictor at the inlet end of the distributor. The restrictor controls the amount of water running over the evaporator. The restrictor cannot be plugged.

If a distributor is replaced it is very important to use the proper size distributor. If the wrong size distributor is installed in an icemaker, water may flow over into the bin area.

When replacing the distributor, note that the small stubs on the outside of the rubber end caps fit into notches on the rear of the side flanges of the evaporator plate. Also, there are small plastic nubs along the back side of the distributor. After the distributor is installed onto the rear of the evaporator plate, it should be turned downward until these nubs are tight against the back of the evaporator.

COMPONENT ACCESS AND TESTING (COMPONENTS IN THE UNIT COMPARTMENT)

If the icemaker has been installed under a counter top, it is usually not necessary to pull out the unit for servicing.

Before removing any component for replacement or testing, make sure power has been disrupted to the unit.

See the note on page 26 about making repairs on the refrigeration sealed system.

WARNING

Electrical Shock Hazard: Disconnect power supply—Failure to do so could result in electrical shock or personal injury.

The water inlet valve, the hot gas valve, the compressor (and starting relay and overload protectors), the condenser, the condenser accumulating tube, the condenser fan, and drier are located in the unit compartment.

To access the Unit compartment:

1. Remove the two (2) screws at the bottom of the grille.

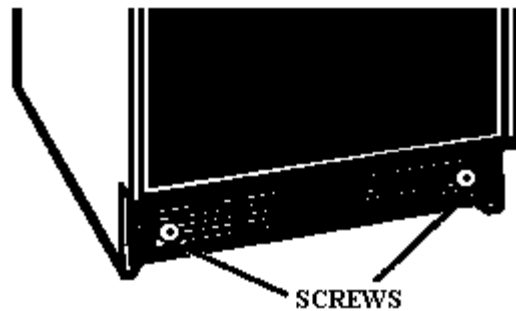

2. Pull the lower panel and grille assembly down and outward, releasing it from the two clips at the top.

There is a baffle separating the unit compartment. During operation of the unit, the air is pulled in through the lower grille on the right side of the baffle, across the condenser, and is pushed out through the lower grille on the left side of the grille.

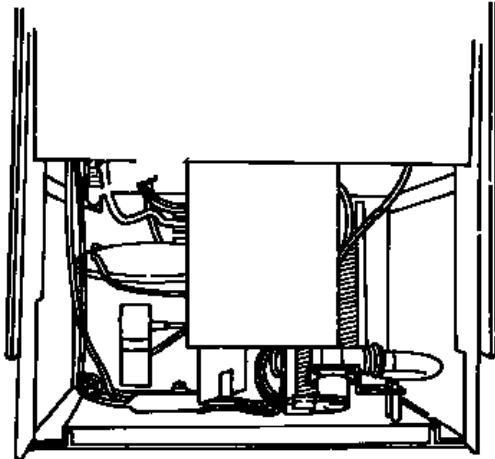

To Remove:

1. Remove the two (2) screws on the compartment side that secure the baffle in place.
2. Carefully remove the baffle.

It is always important that the baffle is replaced properly. If the baffle is not in place during operation, warm air could be continually re-circulated through the unit area, resulting in inefficient operation and low quality ice.

Though it may not be necessary to pull out the unit compartment to access the hot gas valve and water inlet valve, it is necessary to pull out the compartment to access the components in the unit area.

To pull out the Unit compartment:

1. Remove the door, cutter grid assembly, the water reservoir pan, the water pump, the lower panel and grille assembly, and the baffle.
2. Drop the evaporator.
3. Remove the seven (7) screws that secure the shell front, and pull out the shell front.
4. Remove the wire leads from the hot gas valve, the water inlet valve and the compressor starting components.
5. Remove the inlet and outlet water tubes from the water inlet valve.
6. Loosen the two (2) bolts on the side rails at the bottom of the unit compartment.
7. Snap out the retaining spring clips along the left side of the front bin seal.

8. Carefully pull out the unit compartment several inches. Be careful to guide the sealed system tubing forward through the left side of the bin, and through the slit in the upper left front corner of the bin.

Be careful not to bend or kink the refrigeration system tubing.

9. Remove the wire leads from the compressor fan when they become accessible while the unit compartment is being pulled out.
10. Pull the unit compartment out as far as it will come.

When the unit compartment is replaced back into the icemaker, be very careful that the refrigeration system tubing is not bent or kinked. A sealer approved for use in a food machine (non-arsenic) should be used to reseal around the hole in the upper left front corner of the bin.

Condenser Fan:

- 3-watt motor
- 1200 RPM's
- fan blades turn counterclockwise, when facing the motor shaft.

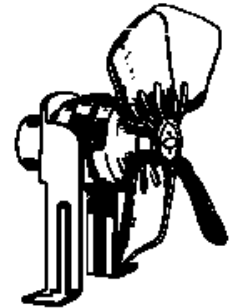

To Check:

1. After removing the wires, use an ohmmeter set on the Rx1 scale.
2. Check across the terminals.

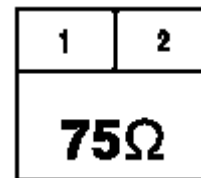

The motor can also be checked by attaching a 120 volt test cord to the terminals. When power is supplied, the fan should operate.

To Remove:

1. Remove the two (2) screws that secure the fan bracket to the base of the unit compartment.
2. Pull out the fan and bracket.
3. Remove the two (2) screws that secure the fan to the fan bracket.

Water Inlet Valve

- Spring-loaded solenoid
- 80-mesh screen in the water inlet

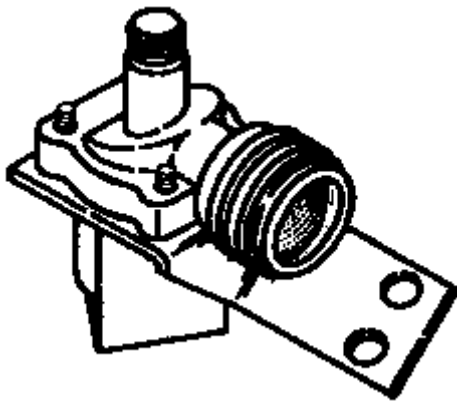

To Check:

1. After removing the wire leads, use an ohmmeter set on the Rx1 scale.
2. Test across the terminals.

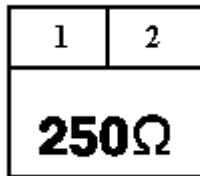

A flow washer in the water inlet valve controls the water flow to approximately 1 quart of water per minute at a supply water pressure of between 20 and 120 pounds per square inch.

To Check For Proper Water Flow:

1. Reconnect the water supply tube to the inlet side of the water valve.
2. Attach a tube to the outlet side of the water valve. Place the other end of the tube in a quart jar held over a pan to catch any overflow.
3. Attach a 120 volt test cord to the terminals.
4. Supply power to the water valve for one minute, noting the water flow into the jar.

In one minute, approximately 1 quart of water should flow into the jar.

To check that the mesh screen and water flow washer is not obstructed, disassemble the water valve.

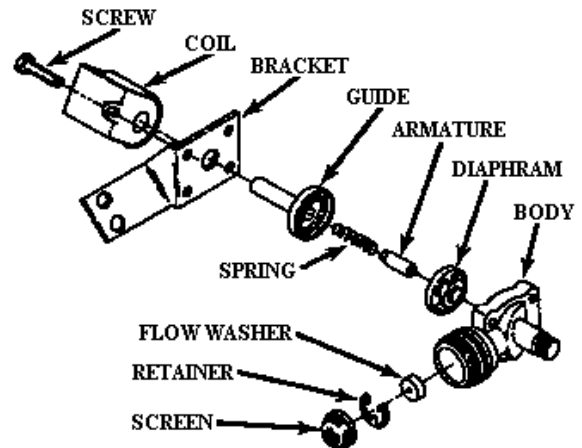

When reassembling the flow washer, note that the side of the washer with lettering must face away from the body of the valve.

Starting Relay

- Magnetic current type
- Plugs directly onto the compressor terminals.

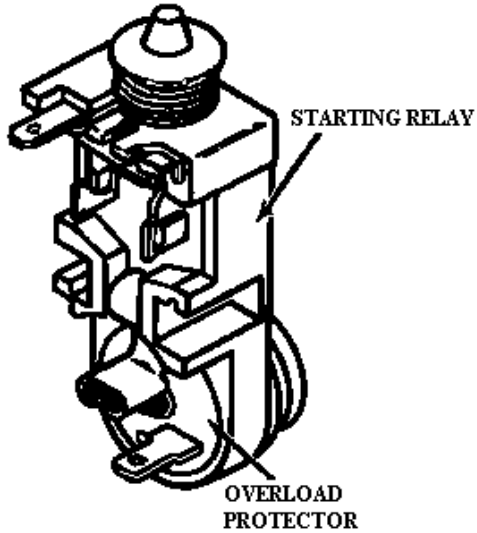

To Check:

1. Remove the relay from the compressor.
2. Use an ohmmeter set on Rx1 scale.
3. With the relay held upright in the same position as it is mounted on the compressor, place the meter probes into the R and S terminal sockets.

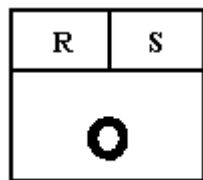

O-Open circuit

4. With the meter probes still in the R and S terminal sockets, invert the relay.

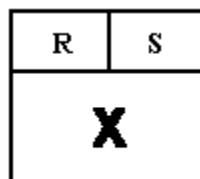

X-closed circuit

Compressor Overload Protector

- Sensitive to current load and to the compressor temperature.
- Mounted on the compressor with the relay.

To Test:

1. With the relay removed from the compressor, use an ohmmeter set on Rx1 scale.
2. Check across the overload terminals.

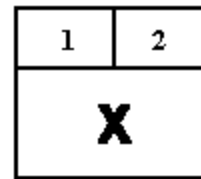

X-closed circuit

Compressor

To Check:

1. Remove the starting components
2. Use an ohmmeter set Rx1 scale.
3. Check from each terminal (C, S, and R) to the compressor housing. The meter probes on the compressor housing should be place on the grounding place, if available, or in an area that is free of paint, such as a stub.

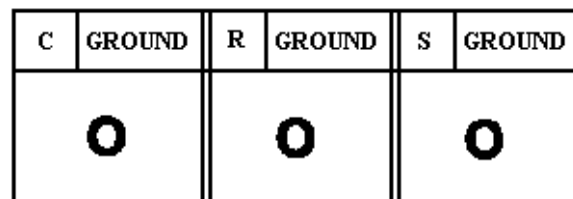

O-Open circuit

4. Now set the ohmmeter on the Rx! Scale.

5. Test across terminals R and C.
6. Test across terminals C and S.

| | | | |
|-------------|---|-----------|---|
| R | C | C | S |
| 2.5Ω | | 7Ω | |

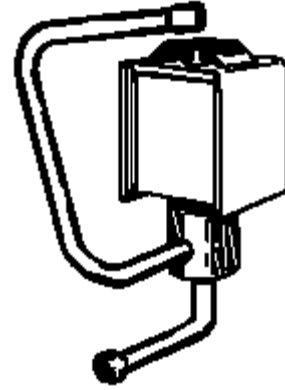

7. Attach a 120 volt test cord to the compressor as shown below.

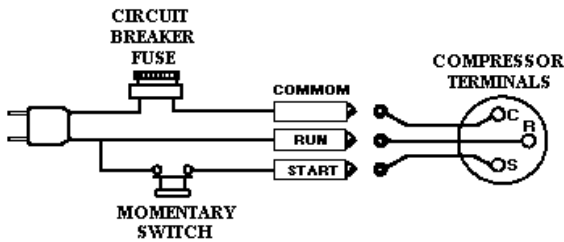

If the compressor does not start, but an audible hum is heard, the compressor needs to be replaced.

If the compressor starts with the test cord, but refuses to run when the icemaker is operating, check for loose wiring, a defective relay, or a defective bin thermostat.

Hot Gas Valve

- Free plunger that seats by gravity.

If the valve plunger does not seat properly, the icemaker will not operate efficiently.

The hot gas valve must be installed vertically.

If there is a small leak in the valve, the outlet tube from the valve will feel cold, and may frost up during the ICE MAKING cycle. This is caused by the small leak acting as an orifice for the refrigerant gas.

If there is a medium sized leak in the valve, the outlet tube from the valve will feel warm during the ICE MAKING cycle.

If the outlet tube from the valve is hot during the ICE MAKING cycle, the hot gas valve is stuck open.

To check:

1. With the wire leads removed, use an ohmmeter set on Rx1 scale.
2. Check across the terminals.

| | |
|-------------|---|
| 1 | 2 |
| 375Ω | |

3. Then attach a 120 volt test cord to the terminals. When power is supplied to the valve you should hear an audible click.

Insulation between the bin and the unit compartment.

Check the insulation for any signs of wetness. If the insulation is wet, or there is a tear or hole poked in the plastic bag, the insulation pack should be replaced.

PROBLEM DIAGNOSIS TROUBLE SHOOTING

Remember that the ice maker has three operating systems.

- ◆ Refrigeration system

- ◆ Water system

- ◆ Electrical system

Each of these three systems must be functioning correctly if the ice maker is to work properly.

It should also be noted that malfunctions in refrigeration system or the water system can often cause problems that look similar.

If a unit is operating, you can often diagnose the source of a problem simply by listening. Remember:

- ◆ The compressor should run continuously during the ICE MAKING cycle.

- ◆ The water pump should run continuously during the ICE MAKING and CLEAN cycle.

- ◆ The water valve is opened (allowing water to enter the unit) only during the HARVEST cycle.

- ◆ The condenser fan should only be running during the ICE MAKING cycle.

WATER AND ITS EFFECT ON ICE MAKING

Quality ice is defined as hard, clear, cold and free of taste or odor. All ice makers will provide this type of quality ice only if the water used to produce the ice is pure and free of mineral or chemical contamination. The chart on the next page helps diagnose problems that can affect ice production.

WHAT'S IN WATER

| INGREDIENT | EFFECT | CORRECTION |
|---|--|---|
| IT AFFECTS ICE QUALITY | | |
| Algae or Sulfides | Objectionable Taste and Odor | Carbon Filter |
| Minerals: Sodium Potassium Manganese Calcium | Cloudy Ice Slow Cutting Refreezing | 1. Check: a. Water flow restriction, b. Correct siphoning. 2. Polyphosphate feeder or water softener. 3. Change water source. |
| B. IT AFFECTS ICE MAKING | | |
| Iron Chlorine Manganese | Staining (Aesthetic only) | 1. Citric acid or liquid ice machine cleaner. (Citric acid works best) 2. Water softener AND iron filter. |
| Permanent Hardness Calcium or Magnesium Sulfates Chlorides Nitrates | Scale | 1. Abrasive cleaning. 2. Polyphosphate feeder or water softener reduces or eliminates abrasive cleaning. |
| Temporary Hardness Calcium or Magnesium Carbonates | Scale | 1. Liquid ice machine cleaner. 2. Polyphosphate feeder or water softener reduces frequency of cleaning by 50%. |
| <p>RECOMMENDATIONS:</p> <p>Water softeners or polyphosphate feeders are not cure-all, but do reduce (and in some cases, prevent) scale build-up. They are particularly effective in controlling sulfate scale, which is rock-like and can be removed only by sanding, scraping or chiseling.</p> <p>Caution: Some polyphosphate feeders cause slime build-up, so their use in low mineral content water should be carefully considered.</p> | | |

(Continued)

When the ice slab takes too long to divide into cubes because the water supply has a high mineral content, a special replacement transformer is available from your parts distributor. This transformer has a selectable 11- volt tap that will increase the heat of the cutter grid wires, helping divide the ice slab into ice cubes faster.

WHAT'S IN THE WATER

C. WATER TESTING

Water testing is necessary to determine the amount of minerals in a water supply that affect ice and the ice maker.

T.D.S. (Total Dissolved Solids) is the test for the total concentration of all minerals present in the water.

Chlorides
Alkalinity
Total Hardness

Are tested to determine the degree of cloudy ice and scale build-up.

Small concentrations of minerals do not affect the ice quality or cause excessive scale build-up. However, amounts which have an adverse effect are:

| TEST | CONCENTRATION | EFFECT ON ICE | EFFECT ON ICE MAKER |
|--------------------------|---|---|---|
| T.D.S. | 50-1000 ppm or higher | Cloudy slow cutting refreezing | Temporary and permanent scale build-up |
| Chlorides | 200-300 ppm or higher | Major cause of cloudy ice, slow cutting, refreezing | Temporary and permanent build-up |
| Alkaloids | 300-400 ppm or higher | Cloudy slow cutting refreezing | Temporary and permanent scale build-up |
| Total 5-10 GPG* hardness | Clear ice (100-170 ppm) 10-15 GPG (170-255 ppm) 15-20 GPG (255-340 ppm) 20 GPG and up (340 ppm and up) | Minimum scale Slightly cloudy Noticeably cloudy possibly slow cutting and refreezing Severely cloudy Slow cutting Refreezing | build-up Moderate scale build-up Serious scale build-up Excessive scale build-up |

*Grains/Gallon

Water treatment companies usually have the equipment to test water. Most city water departments can supply information concerning the mineral content in the water.

TROUBLE SHOOTING GUIDE

| PROBLEM | PROBABLE CAUSE | CORRECTION |
|---|--|---|
| 1. Unit will not Operate | 1a. Service control switch not turned on 1b. Bin is already full of ice up to the bin thermostat. 1c. Power is not available to the unit. | 1a. Turn control service switch on 1b. Check ice level. 1c. Check fuse or breaker, and unit's power plug. |
| 2. Power is available to the unit, but the compressor or water pump is not running. | 2a. Ice is stuck between the wall and the bin thermostat well. 2b. The compressor, relay or overload protector are not operating. 2c. The water pump is not operating. | 2a. If the cutter grid is warm, check for ice between the wall and the bin thermostat. 2b. See component testing section (Page 26). 2c. See component testing section (Page 26) |
| 3. Ice cubes hanging onto the bottom of the cutting grid wires. | 3a. The water valve is restricted. 3b. The drain in the water reservoir pan is restricted. 3c. There is excessive mineral content In the water supply. | 3a. Check water valve assembly and screen for clogging. 3b. Remove restriction. 3c. Check water for increased mineral content. Use charcoal filter to remove minerals. |
| 4. Uneven built-up of white on evaporator plate. | 4a. The water valve is restricted. 4b. There is little or no water in the water reservoir pan. 4c. The drain plug is not in place on bottom of the water reservoir pan. 4d. The water level is over the top of the drain tube in the reservoir pan at the beginning of the ICE MAKING cycle. 4e. The water restrictor or the holes in the distributor are plugged. 4f. The water pump is not operating. | 4a. Check water valve assembly and screen clogged. 4b. Check water pump. 4c. Check drain plug. 4d. Check sump pump operation. 4e. Clean and unplug the distributor holes. 4f. Feel under the pump to make sure the agitator arm has not been broken off. |
| 5. Unit not making ice, compressor running, and water flow over evaporator plate | 5a. The evaporator freezing plate is not getting cold. 5b. The hot gas valve is not operating properly. | 5a. The plate should feel cold during the ICE MAKING cycle. 5b. See component testing section (Page 26) |
| 6. Ice slab not releasing from evaporator plate during the HARVEST cycle. | 6a. The hot gas valve is not operating properly. 6b. The evaporator plate is nicked or scratched, or covered with a mineral build-up. 6c. The condensate pump is not pumping out the water. The pressure switch will terminate the HARVEST cycle. | 6a. See component testing section (Page 26) 6b. Inspect the evaporator plate. replace if damaged. 6c. See component testing section. (Page 26) |

| TROUBLE SHOOTING GUIDE | | |
|---|--|---|
| PROBLEM | PROBABLE CAUSE | CORRECTION |
| 7. Too thick of an ice slab forming sheet. | 7a. The hot gas valve is not operating properly. 7b. The evaporator thermostat is not operating properly. 7c. The evaporator plate is nicked or scratched, or covered with a mineral build-up. | 7a. See component testing section (Page 26) 7b. The thermostat should open and close at the temperatures indicated on the unit's tech 7c. Inspect evaporator plate, replace if necessary. Test water supply for high mineral content. |
| 8. Ice Slab with hollow area in the center. | 8a. The water valve is stuck open. 8b. The hot gas valve is leaking. 8c. The refrigeration sealed system is under charged, or partially restricted. | 8a. Listen for water running out the drain during the ICE MAKING cycle. 8b. See component testing section (Page 26) 8c. Check sealed system for leaks and for restrictions. |
| 9. Ice slab with a lip over the edge front of the evaporator freezer plate. | 9a. The capillary tube has broken loose. | 9a. Check underneath the front for a separation of the capillary from the edge of the evaporator plate. |
| 10. Ice slab with side flanges | 10a. The hot gas valve has a small leak. | 10a. See component testing section (Page 26) |
| 11. Ice ball forming on the capillary tube at the evaporator inlet. | 11a. The bin door is cracked open, or the door seal is leaking. 11b. The insulation bag is not in place blocking the passage of warm air from the unit compartment into the evaporator area. | 11a. Check door seal and replace if damaged. 11b. Reposition the insulation bag. |
| 12. Frost between outlet of the evaporator and the accumulator | 12a. The ice thickness control is set too high, and too thick of an ice slab is forming. 12b. There is an over charge in the refrigeration sealed system. | 12a. Reset the thickness control. 12b. Check sealed system for over charge or restriction. |
| 13. Sweating or frost on suction machine). line. | 13a. The accumulator is not level, (Horizontal). 13b. There is an over charge in the refrigeration sealed system. | 13a. Level accumulator (Ice 13b. Check sealed system for over charge or restrictions. |
| 14. Unit still making ice after bin is full. | 14a. The bin thermostat is not operating properly. (The thermostat should open and close at the temperatures indicated on unit's tech sheet). | 14 a. Check position of thermostat. Change bin thermostat. |

| TROUBLE SHOOTING GUIDE | | |
|---|---|--|
| PROBLEM | PROBABLE CAUSE | CORRECTION |
| 15. Excessive amount of water dripping onto cubes in bin. | 15a. The overflow tube in the water reservoir pan is restricted. 15b. The drain plug is not tightly inserted in the bottom of the reservoir pan. 15c. The water inlet tube is not properly installed into the reservoir pan. 15d. The drain tube is leaking. 15e. Ice is jammed up on the cutter grid, forming a bridge from the evaporator plate. 15f. The lip on the front of the evaporator plate is bent outward. 15g. The deflector, if installed, is not positioned properly. | 15a. Clear the restriction from the overflow tube. 15b. Check and secure the drain plug. 15c. Check position of the water inlet tube. 15d. Replace the drain tube. 15e. Clear ice away from the cutter grid. 15f. straighten or replace evaporator plate. 15g. Check installation and reposition as needed. |
| 16. Ice in bin melting very fast | 16a. The bin door is not closing properly, or the door seals are leaking. 16b. The evaporator plate is nicked, scratched, or has excessive mineral build-up. 16c. The hot gas valve is not operating properly. 16d. The insulation under the bin is wet. 16e. The bin drain partially blocked, causing a slow run off of melting water. 16f. If a water softener is adding too much sodium (salt) to the water supply, the ice produced in the Ice maker will melt at a lower temperature. | 16a. Check door seals for damage, straighten seals or replace. 16b. Check for damage to evaporator plate. Replace if needed. Check for excessive mineral content in water supply. 16c. See component testing section (Page 26) 16d. Check for a hole or tear in the insulation bag. Replace the insulation bag. 16e. Check for kink in the drain hose under the bin, or a blockage inside the bin at the drain. 16f. Check the salt content in the incoming water supply. |
| <p>NOTE: Customers should be informed not to store drinks, juices, etc. in the ice maker.</p> <p>Another phenomena that may be encountered in the ice machine is slushing. Often after servicing a unit, when the unit is powered up, there is the temptation to leave the bin door open to be able to observe that the ICE MAKING cycle begins properly.</p> <p>When warm air is allowed to enter the bin area during the beginning of an ICE MAKING cycle, the water flowing over the evaporator plate may only freeze into a loose slush. This slush will melt off the plate back into the reservoir pan where it may cause the water pump to stall (stop operating).</p> <p>If the bin door is closed after the slushing is noted, the slush in the reservoir pan will rapidly melt and the ice maker Will once again begin to operate properly.</p> | | |

DOOR REMOVAL DETAIL

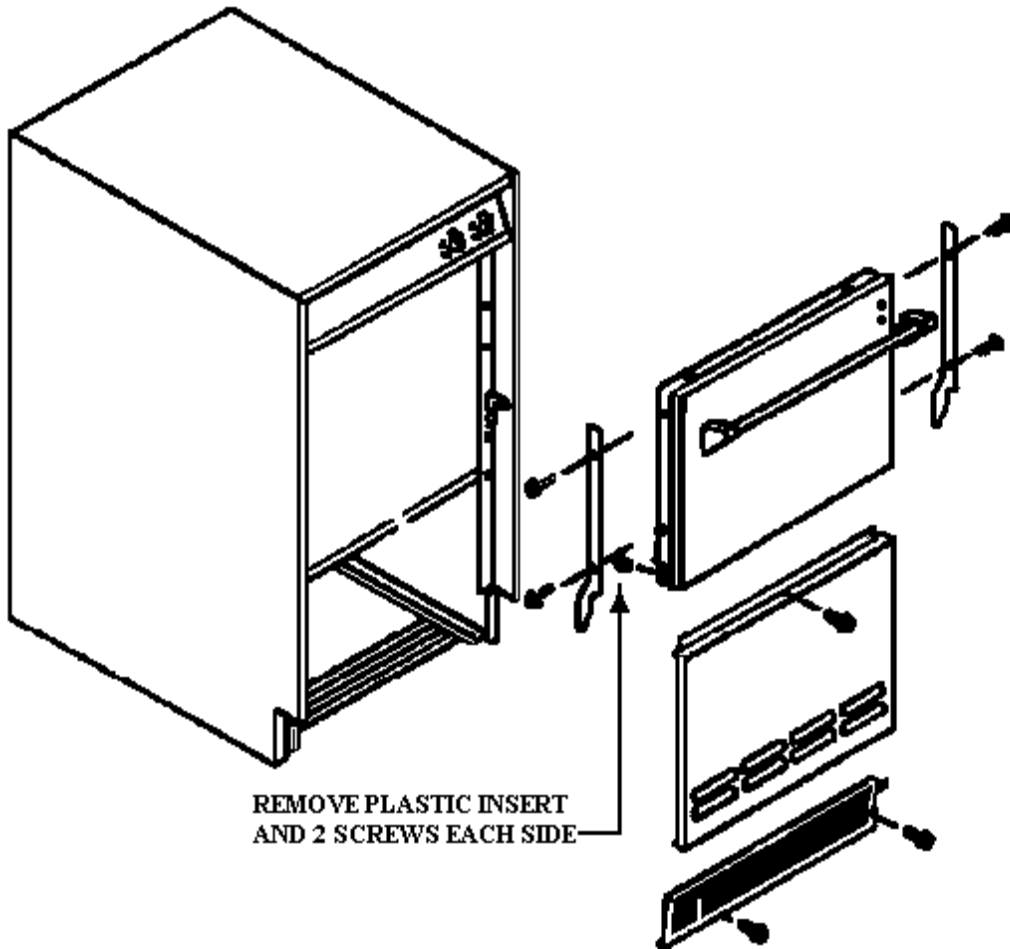

PROBLEM DIAGNOSIS LINEAR LINE CIRCUITS

These line strip circuit diagrams can be used to check the electrical system in the ice maker.

Water Pump (Ice Making Cycle)

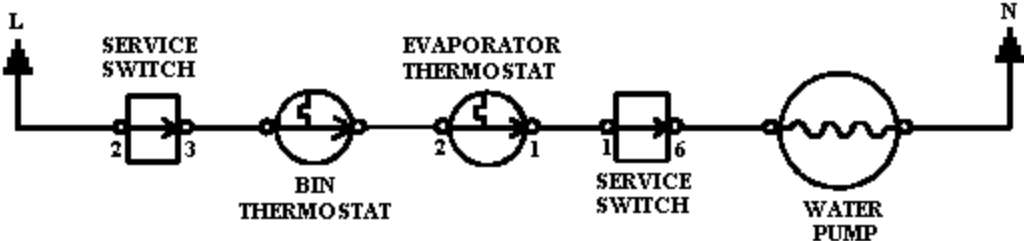

Water Pump (Clean Cycle)

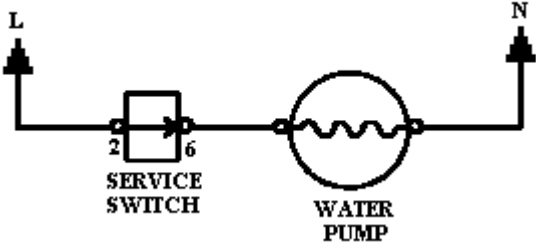

Condenser Fan

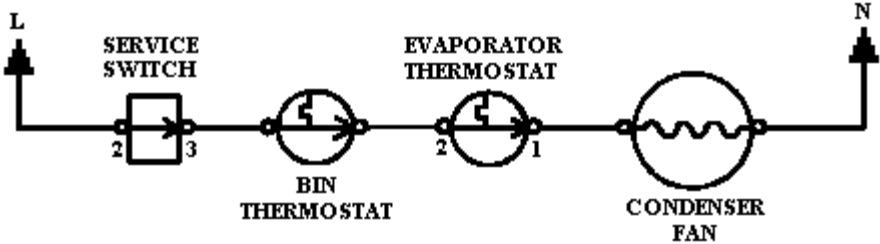

Hot Gas Valve Solenoid (Units With Condensate Drain)

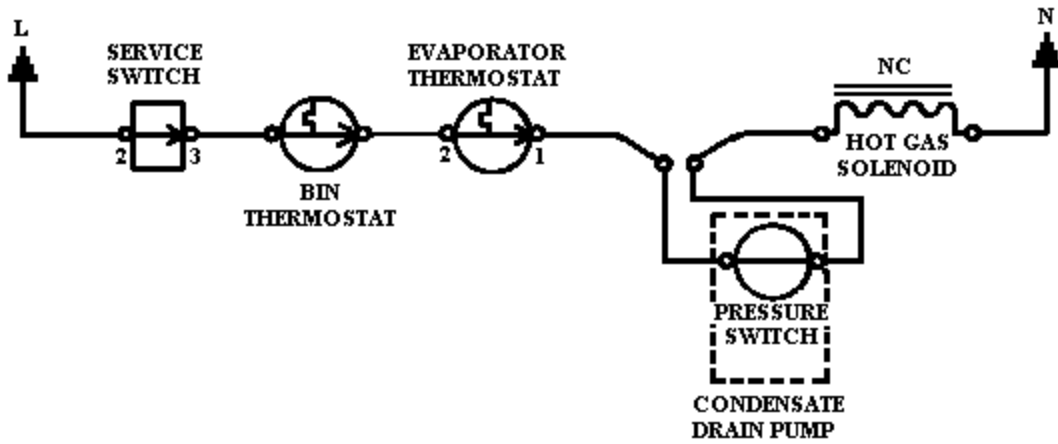

Water Valve Solenoid (Units With Condensate Drain)

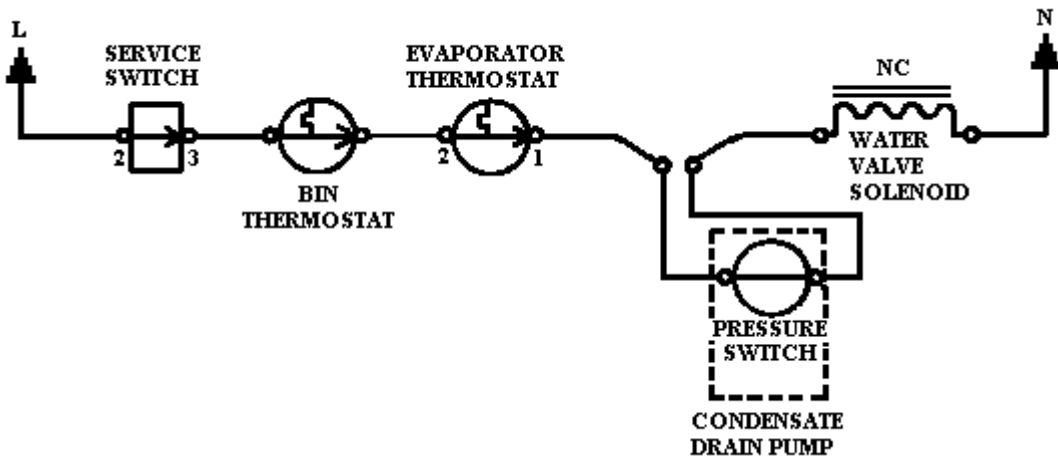

Compressor (Start)

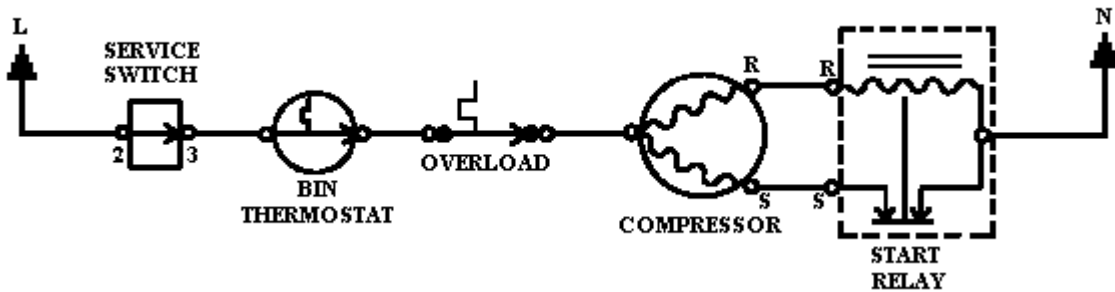

Compressor (Run)

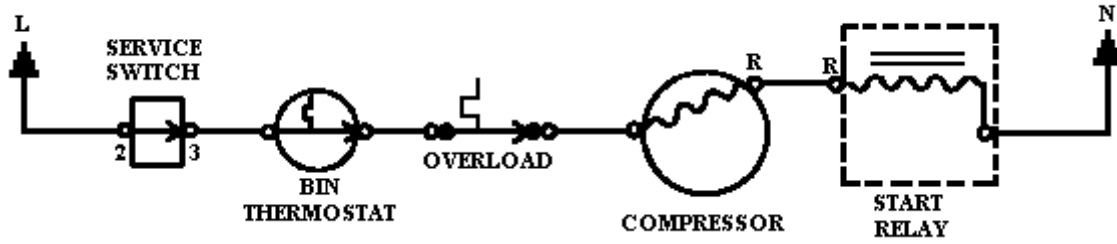

Bin Light

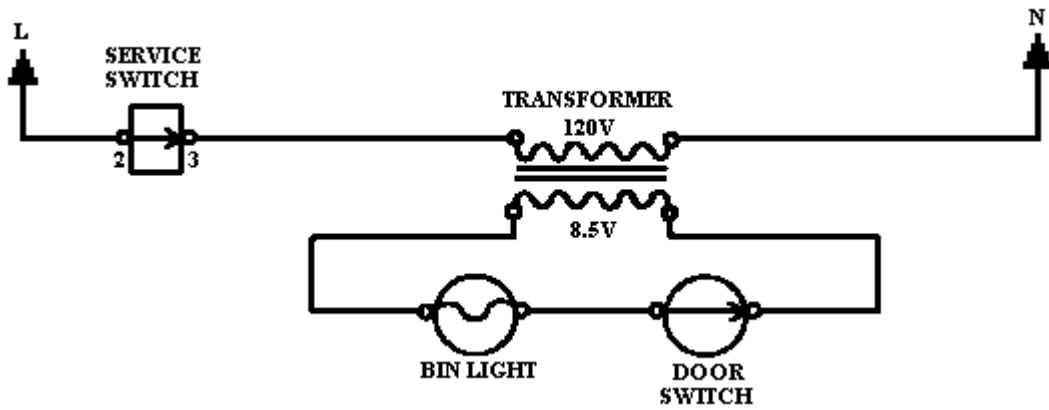

Cutter Grid

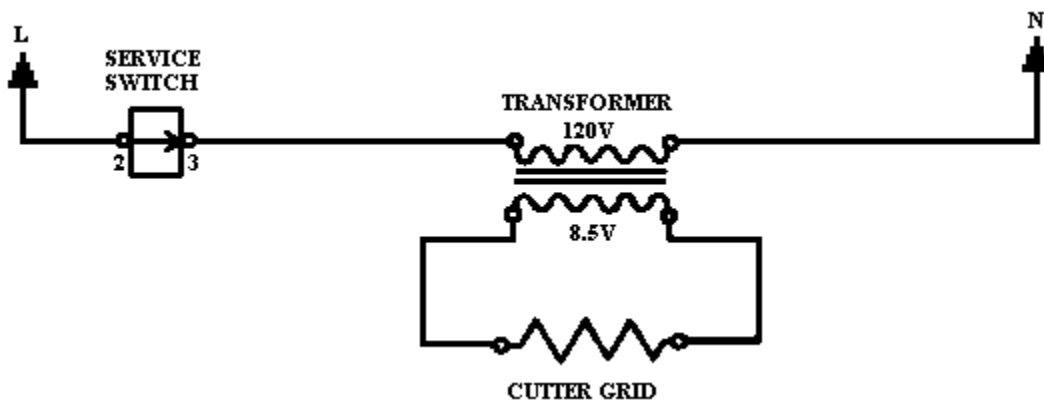

Condensate Pump (HARVEST Cycle)

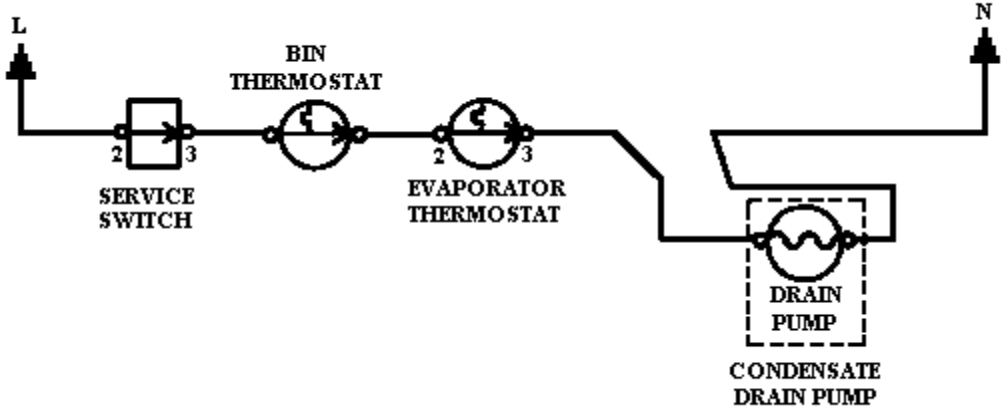

Condensate Pump (at all times except during HARVEST Cycle)

