

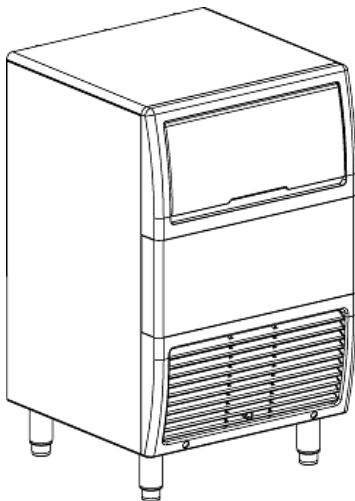

**Manitowoc<sup>®</sup>**

# **SERVICE TECHNICIAN'S HANDBOOK**

## EC Series Ice Machines



This manual is updated as new information and models are released. Visit our website for the latest manual.  
[www.manitowocice.com](http://www.manitowocice.com)

©Manitowoc Ice, Inc.  
P/N 80-1520-3 10/07



## Safety Notices

When using or servicing these Ice Machines, be sure to pay close attention to the safety notices in this handbook. Disregarding the notices may lead to serious injury and/or damage to the ice machine.

Throughout this handbook, you will see the following types of safety notices:



### **Warning**

Text in a Warning box alerts you to a potential personal injury situation. Be sure to read the Warning statement before proceeding, and work carefully.



### **Caution**

Text in a Caution box alerts you to a situation in which you could damage the ice machine. Be sure to read the Caution statement before proceeding, and work carefully.

## Procedural Notices

When using or servicing these Ice Machines, be sure to read the procedural notices in this handbook. These notices supply helpful information that may assist you as you work.

Throughout this handbook, you will see the following types of procedural notices:

### **Important**

Text in an Important box provides you with information that may help you perform a procedure more efficiently. Disregarding this information will not cause damage or injury, but may slow you down as you work.

**NOTE:** Text set off as a Note provides you with simple, but useful extra information about the procedure you are performing.

## Read These Before Proceeding:

### **Caution**

Proper installation, care and maintenance are essential for maximum ice production and trouble free operation of your Manitowoc Ice Machine. If you encounter problems not covered by this manual, do not **proceed**, contact Manitowoc Ice, Inc. We will be happy to provide assistance.

### **Important**

Routine adjustments and maintenance procedures outlined in this manual are not covered by the warranty.

We reserve the right to make product improvements at any time. Specifications and design are subject to change without notice.

### **Warning**

#### **PERSONAL INJURY POTENTIAL**

Do not operate equipment that has been misused, abused, neglected, damaged, or altered/modified from that of original manufactured specifications.

### **Warning**

#### **POTENTIAL PERSONAL INJURY SITUATION**

This ice machine contains refrigerant charge. Installation and Servicing must be performed by a properly trained refrigeration technician aware of the **Dangers of dealing with refrigerant** charged equipment.



# Table of Contents

<b>General Information</b> .....	1
Model Numbers .....	1
<b>Installation</b> .....	2
Location of Ice Machine .....	2
Water Service/Drains .....	3
Electrical Requirements .....	4
Electrical Specifications .....	5
Ice Cube Thickness Check .....	7
Cube Shape .....	8
Sequence of Operation .....	9
<b>No Timer</b>	
Wiring Diagram .....	10
Ice Machine Will Not Run .....	12
Compressor Won't Run .....	13
Compressor Electrical Diagnostics .....	14
Diagnosing Start Components .....	16
Water Pump Won't Run .....	17
Hot Gas Valve Won't Energize .....	18
Water Inlet Valve Won't Energize .....	19
Ice Machine Prematurely Harvests .....	20
Ice Machine Will Not Harvest .....	21
Evaporator Thermostat .....	22
<b>Mechanical Timer</b>	
Wiring Diagram .....	24
Water Pump Won't Run .....	25
Hot Gas Valve Won't Energize .....	26
Water Inlet Valve Won't Energize .....	27
Ice Machine Prematurely Harvests .....	28
Ice Machine Will Not Harvest .....	29
Mechanical Timer .....	30
Low Ambient Adjustment For Mechanical Timer .....	32
Evaporator Thermostat .....	34
<b>SCR Timer</b>	
Wiring Diagram .....	36
Water Pump Won't Run .....	37
Hot Gas Valve Won't Energize .....	38
Water Inlet Valve Won't Energize .....	39
Ice Machine Prematurely Harvests .....	40
Ice Machine Will Not Harvest .....	41

S.C.R. Timer . . . . .	42
Low Ambient Adjustment For SCR Timer . . . . .	43
Evaporator Thermostat . . . . .	44
ON/OFF/WASH Toggle Switch . . . . .	46
Bin Thermostat . . . . .	47
High Pressure Cutout (HPCO) Control . . . . .	47
<b>Refrigeration Diagnostics . . . . .</b>	<b>49</b>
Tubing Schematic . . . . .	49
Ice Production Check . . . . .	51
Water System Checklist . . . . .	52
Analyzing Discharge Pressure . . . . .	53
Discharge Pressure High Checklist . . . . .	54
Freeze Cycle Discharge Pressure Low Checklist . . . . .	55
Analyzing Suction Pressure . . . . .	56
Suction Pressure High Checklist . . . . .	58
Suction Pressure Low Checklist . . . . .	59
Hot Gas Valve . . . . .	60
Discharge Line Temperature Analysis . . . . .	64
Total System Refrigeration Charge . . . . .	66
<b>Cycle Times/24 Hour Ice Production and Refrigerant Pressure Charts . . . . .</b>	<b>67</b>
EC18 Self-Contained Air-Cooled — Mini Cube . . . . .	68
Standard Cube . . . . .	71
EC20 (With Timer) Self-Contained Air-Cooled — Standard Cube . . . . .	74
Large Cube . . . . .	77
EC20 (Without Timer) Self-Contained Air-Cooled — Mini Cube . . . . .	80
Standard Cube . . . . .	83
EC30 Self-Contained Air-Cooled — Standard Cube . . . . .	86
Large Cube . . . . .	89
EC30 (Serial Break not available) Self-Contained Air-Cooled — Standard Cube . . . . .	92
Large Cube . . . . .	95



EC40 Self-Contained Air-Cooled —	
Standard Cube . . . . .	98
Large Cube . . . . .	101
EC40 Self-Contained Water-Cooled —	
Standard Cube . . . . .	104
Large Cube . . . . .	107
EC50 Self-Contained Air-Cooled —	
Standard Cube . . . . .	110
Large Cube . . . . .	113
EC50 Self-Contained Water-Cooled —	
Standard Cube . . . . .	116
Large Cube . . . . .	119
EC65 Self-Contained Air-Cooled —	
Standard Cube . . . . .	122
Large Cube . . . . .	125
EC65 Self-Contained Water-Cooled —	
Standard Cube . . . . .	128
Large Cube . . . . .	131
EC80 Self-Contained Air-Cooled —	
Standard Cube . . . . .	134
Large Cube . . . . .	137
EC80 Self-Contained Water-Cooled —	
Standard Cube . . . . .	140
Large Cube . . . . .	143
Power Consumption - kwh per 24 hours . . . . .	146
Ice Machine Heat of Rejection . . . . .	148
<b>Refrigerant . . . . .</b>	<b>149</b>
Recover/Evacuation/Charging . . . . .	149
System Contamination Cleanup . . . . .	152
Mild System Contamination Cleanup . . . . .	154
Severe System Contamination	
Cleanup Procedure . . . . .	155
Filter-Driers . . . . .	157



# General Information

## MODEL NUMBERS

This manual covers the following models:

<b>Self-Contained Air-Cooled</b>	<b>Water-Cooled and Remote</b>
ECM018A	---
ECS018A	---
ECM020A	ECM020W
ECS020A	ECS020W
ECG020A	ECG020W
ECM030A	ECM030W
ECS030A	ECS030W
ECG030A	ECG030W
ECM040A	ECM040W
ECS040A	ECS040W
ECG040A	ECG040W
ECM050A	ECM050W
ECS050A	ECS050W
ECG050A	ECG050W
ECM065A	ECM065W
ECS065A	ECS065W
ECG065A	ECG065W
ECM080A	ECM080W
ECS080A	ECS080W
ECG080A	ECG080W

# Installation

## LOCATION OF ICE MACHINE

The location selected for the ice machine must meet the following criteria. If any of these criteria are not met, select another location.

- The location must be indoors.
- The location must be free of airborne and other contaminants.
- The air temperature must be at least 10°C but must not exceed 43.4°C.
- The location must not be near heat-generating equipment or in direct sunlight.
- The location must be capable of supporting the weight of the ice machine and a full bin of ice.
- The location must allow enough clearance for water, drain, and electrical connections in the **rear of the ice machine**.
- The location must not obstruct airflow through or around the ice machine (condenser airflow is in and out the front). Refer to the chart below for clearance requirements.

	<b>Self-Contained Air-Cooled</b>	<b>Self-Contained Water-Cooled</b>
Top/Sides	203 mm (8")*	127 mm (5")*
Back	127 mm (5")*	127 mm (5")*

**\*NOTE:** The ice machine may be built into a cabinet.

There is no minimum clearance requirement for the top or left and right sides of the ice machine. The listed values are recommended for efficient operation and servicing only.

## **WATER SERVICE/DRAINS**

### **Water Supply**

Local water conditions may require treatment of the water to inhibit scale formation, filter sediment, and remove chlorine odor and taste.

### **Water Inlet Lines**

- Do not connect the ice machine to a hot water supply. Be sure all hot water restrictors installed for other equipment are working. (Check valves on sink faucets, dishwashers, etc.)
- If water pressure exceeds the maximum recommended pressure, 5 bar (500 kPA), install a water pressure regulator.
- Install a water shut-off valve.

### **Drain Connections**

- Drain lines must have a 2.5 cm per meter drop, and must not create traps.
- The floor drain must be large enough to accommodate drainage from all drains.

#### **Caution**

The ice machine must be protected if it will be subjected to temperatures below 0°C. Failure caused by exposure to freezing temperatures is not covered by the warranty.

## **ELECTRICAL REQUIREMENTS**

### **Voltage**

The maximum allowable voltage variation is  $\pm 6\%$  of the rated voltage on the ice machine model/serial number plate at start-up (when the electrical load is highest).

All ice machines are factory pre-wired with a power cord only, no plug is supplied.

### **Fuse/Circuit Breaker**

A separate fuse/circuit breaker must be provided for each ice machine. An electrical disconnect switch must be provided if the ice machine is hard wired (wired without a plug).

### **Total Circuit Ampacity**

The total circuit ampacity is used to help select the wire size of the electrical supply.

The wire size (or gauge) is also dependent upon location, materials used, length of run, etc., so a qualified electrician must make the determination.

## ELECTRICAL SPECIFICATIONS

Ice Machine	Air			Water		
	Voltage Phase Cycle	Max. Fuse/ Circuit Breaker	Total Amps	Voltage Phase Cycle	Max. Fuse/ Circuit Breaker	Total Amps
EC18	115/60/1			NA	NA	
	230/50/1	10 amp	2.2	NA	NA	
	230/60/1	10 amp	2.2	NA	NA	
EC20	115/60/1			115/60/1	NA	
	230/50/1	10 amp	2.5	230/50/1	10 amp	2.3
	230/60/1	10 amp	2.5	230/60/1	10 amp	2.3
EC30	115/60/1			115/60/1		
	230/50/1	10 amp	3.4	230/50/1	10 amp	3.2
	230/60/1	10 amp	3.4	230/60/1	10 amp	3.2
EC40	230/50/1	10 amp	3.4	230/50/1	10 amp	3.1
	230/60/1	10 amp	3.4	230/60/1	10 amp	3.1

EC50	115/60/1			115/60/1		
	230/50/1	10 amp	4.0	230/50/1	10 amp	3.7
	230/60/1	10 amp	4.0	230/60/1	10 amp	3.7
EC65	115/60/1			115/60/1		
	230/50/1	10 amp	4.2	230/50/1	10 amp	3.8
	230/60/1	10 amp	4.2	230/60/1	10 amp	3.8
EC80	115/60/1			115/60/1		
	230/50/1	10 amp	4.4	230/50/1	10 amp	4.0
	230/60/1	10 amp	4.4	230/60/1	10 amp	4.0



## ICE CUBE THICKNESS CHECK

The ice cube thickness is factory-set to maintain the ice cube thickness at the proper size and weight.

Allow the ice machine to operate for three complete cycles. The cubes should have a small dimple in the center.

Cycle times vary, according to surrounding air and water inlet temperatures.

If cubes are not full (large dimple), turn evaporator thermostat one increment towards the right to increase cube size. Allow ice machine to complete three cycles, then check cubes.

If cubes are too full, (no dimple), turn evaporator thermostat one increment towards the left to decrease cube size. Allow ice machine to operate three complete cycles, then check cubes.



**Ice Cube Adjustment**

## CUBE SHAPE

The mini cube has an average weight of 8 grams, the standard cube has an average weight of 19 grams, and the large cube has an average weight of 32 grams.

Notice the normal dimple in the center of the cube.

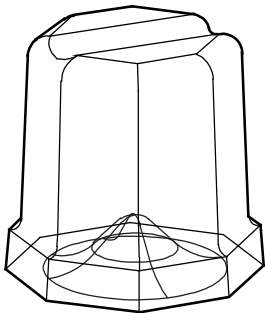

## SEQUENCE OF OPERATION

### Initial Start-Up

#### PRIMING WATER SYSTEM

The water inlet valve on this machine energizes in the harvest sequence, therefore priming the system with water will allow the system to start up with a full reservoir of water. To prime system, remove water curtain, and add 2 liters of water into the water trough.

#### 1. Freeze Cycle

Turn the ON/OFF/WASH switch to ON. The compressor, and water pump will energize, starting the freeze cycle. The pump sprays water into the inverted cups. The water freezes layer by layer, until an ice cube forms in each cup.

At the same time the compressor starts, the condenser fan motor (air-cooled models) is supplied with power throughout the freeze and harvest cycles. The freeze cycle continues and the evaporator thermostat reaches the adjusted set point.

- No Timer

A harvest cycle starts

- Mechanical Timer

The thermostat energizes the timer motor and the cam starts to turn. When the cam cycles through the preset freeze time the relays change position and the harvest cycle is initiated.

- SCR Timer

The thermostat energizes the time delay relay. When the timer reaches setpoint (10 minutes factory setting) the harvest cycle is initiated.

# Wiring Diagram

No Timer

SEE SERIAL PLATE FOR VOLTAGE

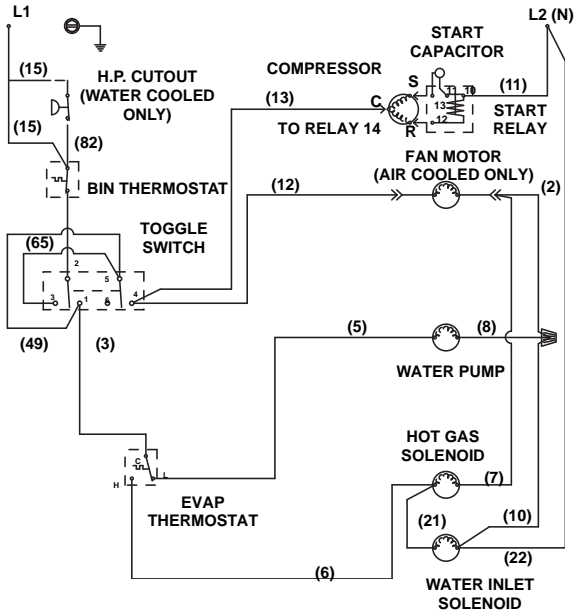

## Caution

Disconnect power before working on electrical circuitry.

## **2. Harvest Cycle**

The compressor continues to operate and the water pump is de-energized. The hot gas valve energizes, allowing hot gas to enter and warm the evaporator. The water valve is also energized, aiding with harvest, as well as filling up the sump with fresh water for a new freeze cycle.

The ice falls from the cups and is directed into the bin by the ice chute. The harvest cycle continues until:

- No Timers

The evaporator thermostat changes position.

- Mechanical Timer

The preset harvest time expires.

The hot gas valve and water valve de-energize. If ice cubes are not contacting the bin thermostat, a new freeze cycle is initiated as the water pump energizes and sprays water into the cups.

- SCR Timer

The timer reaches the factory setting of 3 minutes.

## **3. Automatic Shut-Off**

When the storage bin is full, the ice will come in contact with the bin thermostat which is located inside the bin. The machine will stop after approximately one minute of continuous ice contact with the bin thermostat probe.

The ice machine remains off until enough ice has been removed from the storage bin to allow the ice to fall clear of the bin thermostat probe. As the ice clears the probe, the bin thermostat warms up and the machine starts another freeze cycle.

# Diagnosing an Ice Machine

## ICE MACHINE WILL NOT RUN

Nothing on the ice machine will operate (compressor, water pump, condenser fan motor). If any component runs this procedure can be skipped, move on to the next diagnostics (water pump won't run, compressor won't run, etc).

1. Place the toggle switch in the clean position. If the water pump runs begin with toggle switch diagnostics. If water pump does not run place toggle switch in ice position.
2. Verify correct voltage is present and matches nameplate voltage.
3. High pressure switch must be closed on water cooled ice machines — move on to #4 if air cooled ice machine (If you have voltage at L1 and no voltage at #15 on the Bin Thermostat, which is easy to access, the HPCO is open).
4. Bin thermostat must be closed before any components can be energized. Check for voltage at wires #15 and #64.

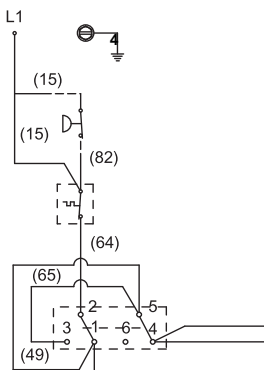

## COMPRESSOR WON'T RUN

If the water pump is running and the compressor is not, it may be tripping on overload or tripping the breaker/fuse. Check for grounded winding if breaker keeps tripping.

1. Toggle switch terminals 5 & 4 closed?  
(wires #49 & #13)
2. Start capacitor and relay function?
3. Compressor windings closed?
4. Refer to compressor diagnostics.

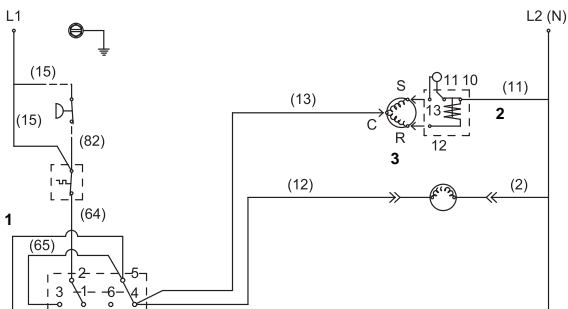

## **COMPRESSOR ELECTRICAL DIAGNOSTICS**

The compressor does not start or will trip repeatedly on overload.

### **Check Resistance (OHM) Values**

**NOTE:** Compressor windings can have very low ohm values. Use a properly calibrated meter.

Perform the resistance test after the compressor cools. The compressor dome should be cool enough to touch (below 49°C) to assure that the overload is closed and the resistance readings will be accurate.

### **Single Phase Compressors**

1. Disconnect power from the condensing unit and remove the wires from the compressor terminals.
2. The resistance values between C and S and between C and R, when added together should equal the resistance value between S and R.
3. If the overload is open, there will be a resistance reading between S and R, and open readings between C and S and between C and R. Allow the compressor to cool, then check the readings again.

### **Check Motor Windings to Ground**

Check continuity between all three terminals and the compressor shell or copper refrigeration line. Scrape metal surface to get good contact. If continuity is present, the compressor windings are grounded and the compressor should be replaced.

To determine if the Compressor is seized check the amp draw while the compressor is trying to start.



## **Compressor Drawing High Amps**

The continuous amperage draw on start-up should not be near the maximum fuse size indicated on the serial tag.

The wiring must be correctly sized to minimize voltage drop at compressor start-up. The voltage when the compressor is trying to start must be within (6% of the nameplate voltage).

## **Compressor Drawing Locked Rotor**

The three likely causes of this are:

- Low voltage supply (check voltage while compressor is trying to start)
- Defective starting component
- Mechanically seized compressor

To determine which you have:

- Install high and low side gauges.
- Try to start the compressor.
- Watch the pressures closely.

If the pressures do not move, the compressor is seized. Replace the compressor.

If the pressures move, the compressor is turning slowly and is not seized. Check the capacitors and relay.

## **DIAGNOSING START COMPONENTS**

If the compressor attempts to start, or hums and trips the overload protector, check the start components before replacing the compressor.

### **Capacitor**

Visual evidence of capacitor failure can include a bulged terminal end or a ruptured membrane. Do not assume a capacitor is good if no visual evidence is present. A good test is to install a known good substitute capacitor. Use a capacitor tester when checking a suspect capacitor. Clip the bleed resistor off the capacitor terminals before testing.

### **Current Relay**

The relay has a set of contacts that energize and de-energize the compressor start winding. The contacts on the relay are normally open (start winding de-energized). When power is applied the run winding will be at LRA. The relay coil will become an electromagnet and close the contacts (start winding energized). As the compressor motor RPM increases, the run winding current draw and relay coil magnetism decrease allowing the contacts to open. Replace a suspect relay with a known good relay, or use a momentary switch and start capacitor to mimic relay operation.

# WATER PUMP WON'T RUN

## No Timer

1. Toggle switch terminals 2 & 1 closed?  
(wires #64 & #3)
2. Evaporator thermostat C & L contacts closed?  
(wires #3 & #5)
3. Water pump winding closed?

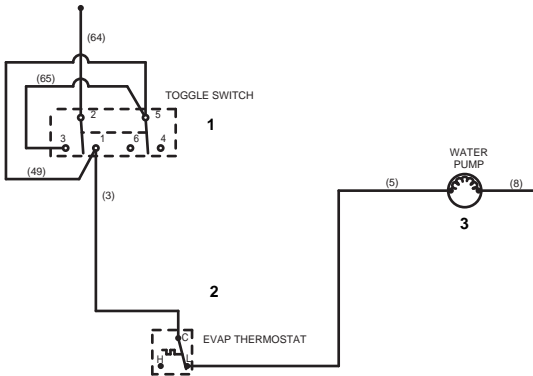

## HOT GAS VALVE WON'T ENERGIZE

### No Timer

1. Line voltage at hot gas valve? (Wires 6 & 7)
  - Yes - Replace hot gas valve coil.
  - No - Refer to evaporator thermostat diagnostics.

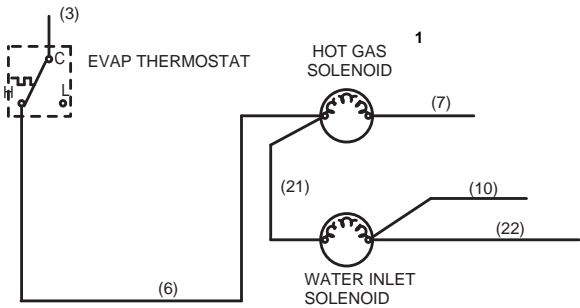

## WATER INLET VALVE WON'T ENERGIZE

### No Timer

1. Line voltage at water inlet valve? (Wires 21 & 22)
  - Yes - Replace water inlet valve coil.
  - No - Refer to evaporator thermostat diagnostics.

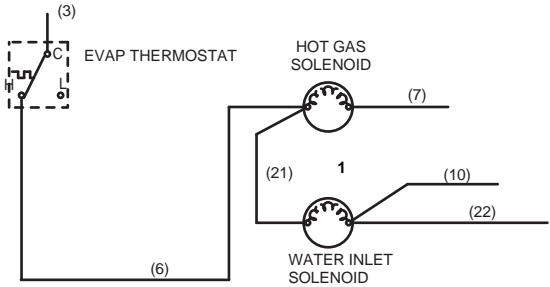

## ICE MACHINE PREMATURELY HARVESTS

### No Timer

1. Line voltage at hot gas valve?
  - > No - Replace hot gas valve.
2. Refer to evaporator thermostat diagnostics.

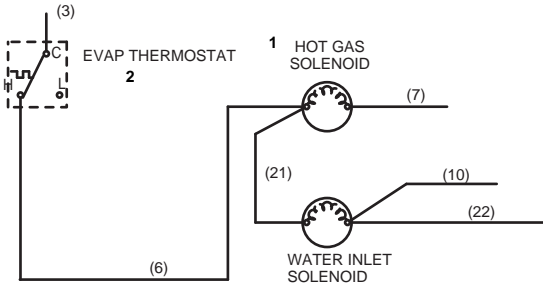

# ICE MACHINE WILL NOT HARVEST

## No Timer

1. Evaporator temperature below setpoint?
2. Evaporator thermostat cap tube inserted correctly?  
(Flush with end of bulb well)
3. Evaporator thermostat closed?  
(wires #4 & timer motor)
4. Line voltage at hot gas valve and water inlet Solenoid?

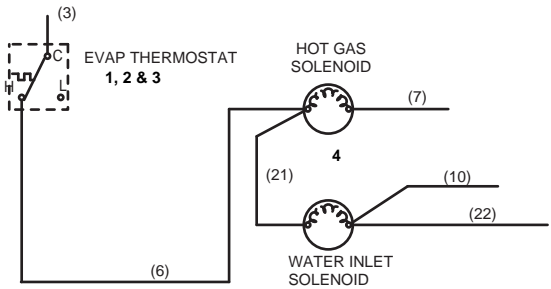

## **EVAPORATOR THERMOSTAT**

### **Function**

Mechanical Timer - Energizes the timer motor when the evaporator temperature drops below the control set point.

SCR Timer - Supplies and removes power to SCR trigger.

No Timer - Initiates and terminates freeze and harvest cycles.

### **Operation**

Thermostat contacts C & L are closed at temperatures above cut in and contacts C & H are closed at temperatures below cut in.

### **Setting Control For Proper Operation**

Correct setting will vary with operating ambient. To obtain correct setpoint, capture and weigh the ice from 1 freeze cycle (refer to ice production check for complete details).

Refer to Cycle Time/24 hour Ice Production charts for correct cube weight and quantity. White or mishappen cubes indicate cleaning is required.



## Check Procedure

1. Make sure bulb is inserted correctly (flush with end of bulb well).
2. Check evaporator temperature — is evaporator frosted?
3. Move the thermostat adjustment to the coldest and warmest setting, did the contacts change position?
4. Attach a thermocouple and measure the temperature at the bulb. At 0°C the thermostat can be adjusted warmer or colder to change contact positions. If readings do not match chart, replace the thermostat.

<b>Temperature</b>	<b>Contacts C &amp; L</b>	<b>Contacts C &amp; H</b>
Above Setpoint @ Bulb	Closed	Open
Below Setpoint @ Bulb	Open	Closed

# Wiring Diagram

## Mechanical Timer

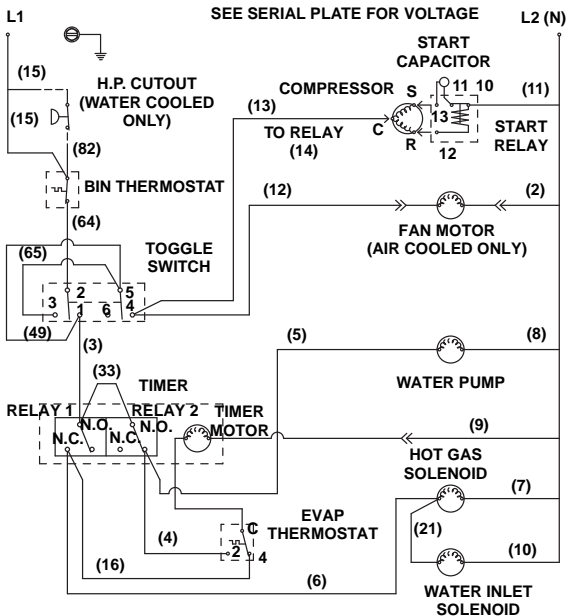

### Caution

Disconnect power before working on electrical circuitry.

# WATER PUMP WON'T RUN

## Machanical Timer

1. Toggle switch terminals 2 & 1 closed?  
(wires #64 & #3)
2. Timer micro switch closed (relay 2)?  
(wires #33 & #5)
3. Water pump winding closed?

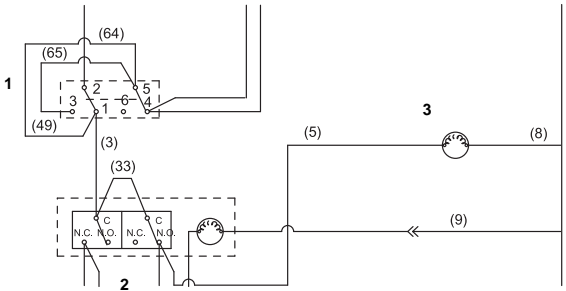

# HOT GAS VALVE WON'T ENERGIZE

## Mechanical Timer

1. Toggle switch terminals 2 & 1 closed?  
(wires #64 & #3)
2. Timer micro switch closed (relay 1)?  
(wires #3 & #6)
3. Hot gas valve coil winding closed?

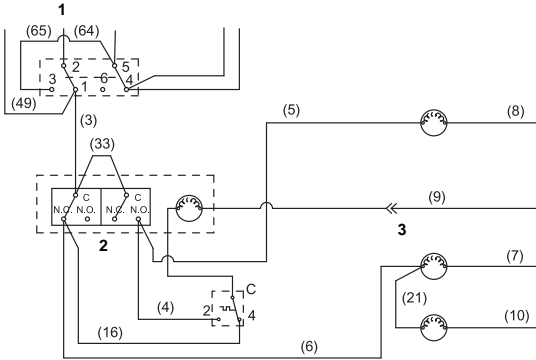

# WATER INLET VALVE WON'T ENERGIZE

## Mechanical Timer

The hot gas valve and water inlet valve energize together in the harvest cycle. If the hot gas valve energizes verify #1 and then go right to #4.

1. Water supplied to the ice machine?
2. Toggle switch terminals 2 & 1 closed?  
(wires #64 & #3)
3. Timer micro switch closed (relay 1)?  
(wires #3 & #6)
4. Water inlet valve coil winding closed?

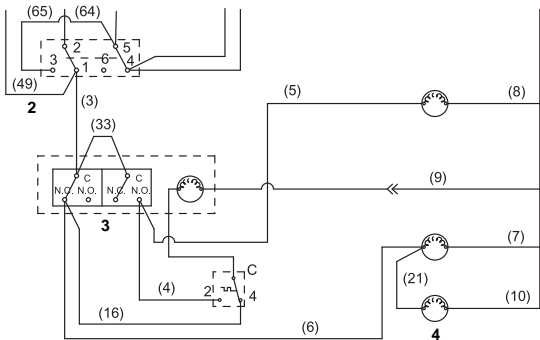

# ICE MACHINE PREMATURELY HARVESTS

## Mechanical Timer

1. Evaporator thermostat correctly set?
2. Timer micro switch relays in N.O. position?  
(wires #3 & #6-16 open - wires #33 & #4-5 closed)
3. Evaporator thermostat terminals #2 & #3  
(Common) open?
4. Timer motor winding closed?
5. Timer functions mechanically?
6. Timer cam changes relay micro switch position?  
(relay 1 - wires #3 & #6-16 must close)

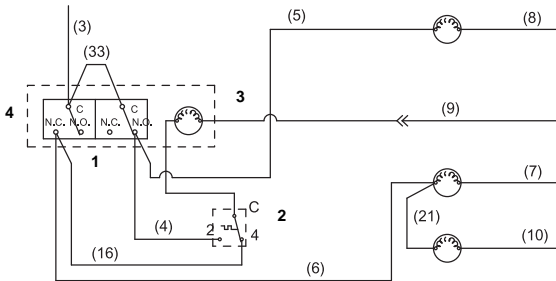

# ICE MACHINE WILL NOT HARVEST

## Mechanical Timer

1. Evaporator temperature below setpoint?
2. Evaporator thermostat cap tube inserted correctly?  
(Flush with end of bulb well)
3. Evaporator thermostat closed?  
(wires #4 & timer motor)
4. Timer motor winding closed?
5. Timer functions mechanically?
6. Timer cam changes micro switch position?  
(relay 1 - wires #3 & #6 must close)
7. Micro switch functions?
8. Line voltage at hot gas valve and water inlet  
Solenoid? (wires #6 & #7 - wires #21 & #10)

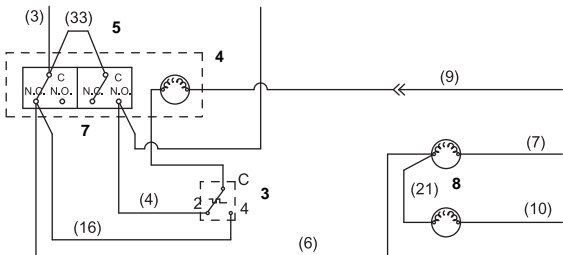

## **MECHANICAL TIMER**

### **Function**

Extends the length of the freeze cycle (after the evaporator thermostat closes), initiates and terminates the harvest cycle.

### **Operation**

- Factory Setting is 11.5 minute freeze cycle, 3.5 minutes harvest.
- Total freeze cycle time = the time it takes to close the evaporator thermostat plus 11.5 minutes.
- Changing the length of the freeze cycle changes the length of the harvest cycle and vice versa. Example 12 minute freeze = 3 minute harvest

### **DURING THE FREEZE CYCLE**

After the evaporator thermostat closes, the timer is supplied with power. The cam turns and the ice machine remains in freeze until the arm for the micro switch changes position at the cam lobe.

### **DURING THE HARVEST CYCLE**

The ice machine remains in harvest until the arm for the micro switch changes position at the cam lobe again.



## **Mechanical Timer Diagnostics**

1. Check for line voltage at the timer motor.  
(Evaporator thermostat completes timer Motor Circuit. If no voltage is present refer to evaporator thermostat diagnostics.)
2. If timer has voltage and does not move:
  - Check motor windings.
  - If windings are open or have resistance and timer does not move, replace timer.
3. If timer cam moves:
  - Check micro switch for voltage.
  - Check micro switch for continuity.

## LOW AMBIENT ADJUSTMENT FOR MECHANICAL TIMER

Timer adjustment for operation in temperatures below 10°C.

1. Disconnect power to the ice machine.
2. Remove timer adjustment tool from the inside of the control box cover.
3. Adjust harvest time to 5 minutes (easier access can be obtained by removing the timer mounting screws).
4. One time adjustment, the timer does not need to be readjusted for summer/winter operation.

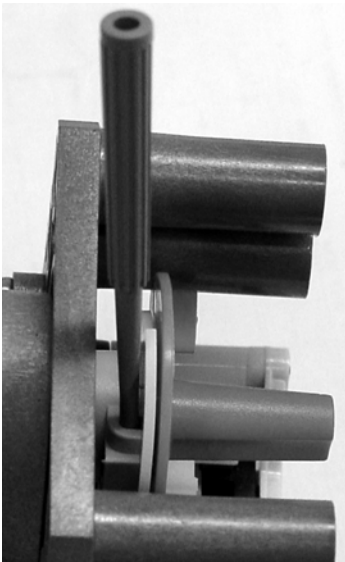

## **Diagnostics**

### **Ice machine will not initiate a harvest cycle**

1. Check for line voltage at terminals 1 & 2 and C (Common) & 2. If line voltage is not present refer to toggle switch diagnostics.
2. Check for line voltage at 2 & 6.
  - No line voltage

Refer to evaporator thermostat diagnostics.

Evaporator temperature must be below 0°C.

- Line Voltage

Momentarily disconnect then reconnect power to #6.

3. Wait 11 minutes.
  - Ice machine cycles into harvest - Refer to evaporator thermostat diagnostics. The evaporator thermostat must open the trigger contact (#6) to reset the freeze cycle time. If power is not broken at # 6 the ice machine will remain in the freeze cycle and never initiate a harvest cycle.
  - Ice machine remains in freeze - Replace timer.

### **Ice Machine Remains In Harvest**

1. Disconnect wire from NO (normally open) terminal.

- Ice machine remains in harvest.

Refer to hot gas valve diagnostics

- Ice machine starts freeze cycle

Replace timer.

### **Hot gas valve and water inlet valve chatter**

Timer is failed half wave, replace timer

## **EVAPORATOR THERMOSTAT**

### **Function**

Mechanical Timer - Energizes the timer motor when the evaporator temperature drops below the control set point.

SCR Timer - Supplies and removes power to SCR trigger.

No Timer - Initiates and terminates freeze and harvest cycles.

### **Operation**

Thermostat contacts C & L are closed at temperatures above cut in and contacts C & H are closed at temperatures below cut in.

### **Setting Control For Proper Operation**

Correct setting will vary with operating ambient. To obtain correct setpoint, capture and weigh the ice from 1 freeze cycle (refer to ice production check for complete details).

Refer to Cycle Time/24 hour Ice Production charts for correct cube weight and quantity. White or mishappen cubes indicate cleaning is required.

## Check Procedure

1. Make sure bulb is inserted correctly (flush with end of bulb well).
2. Check evaporator temperature — is evaporator frosted?
3. Move the thermostat adjustment to the coldest and warmest setting, did the contacts change position?
4. Attach a thermocouple and measure the temperature at the bulb. At 0°C the thermostat can be adjusted warmer or colder to change contact positions. If readings do not match chart, replace the thermostat.

<b>Temperature</b>	<b>Contacts C &amp; L</b>	<b>Contacts C &amp; H</b>
Above Setpoint @ Bulb	Closed	Open
Below Setpoint @ Bulb	Open	Closed

# Wiring Diagram

## SCR Timer

SEE SERIAL PLATE FOR VOLTAGE

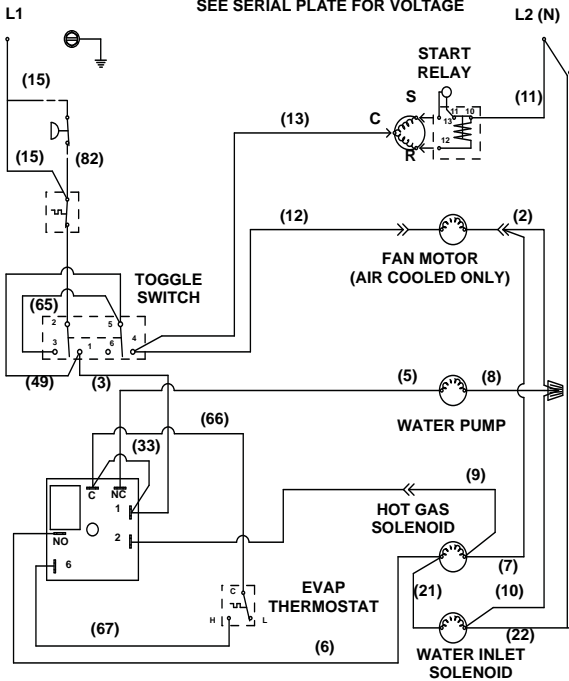

### Caution

Disconnect power before working on electrical circuitry.

# WATER PUMP WON'T RUN

## SCR Timer

1. Toggle switch terminals 2 & 1 closed?  
(wires #64 & #3)
2. Timer relay closed?  
(wires #3 & #5 - contacts C & NC on timer)
3. Water pump winding closed?

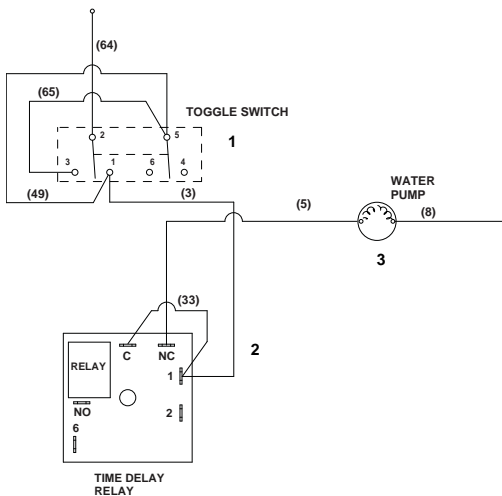

## HOT GAS VALVE WON'T ENERGIZE

### SCR Timer

1. Line voltage at hot gas valve? (Wires 6 & 7)

- Yes - Replace hot gas valve coil.
- No - Refer to SCR timer diagnostics.

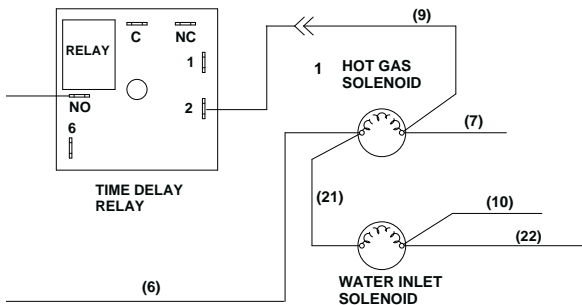



## WATER INLET VALVE WON'T ENERGIZE

### SCR Timer

1. Line voltage at water inlet valve? (Wires 21 & 22)

- Yes - Replace water inlet valve.
- No - Refer to SCR timer diagnostics.

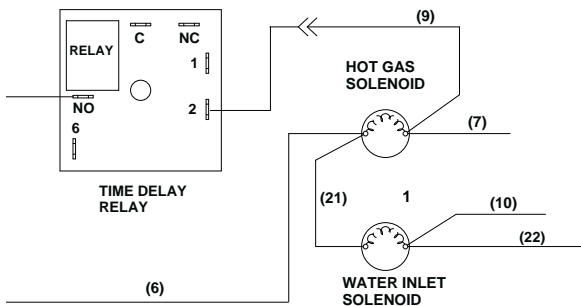

## ICE MACHINE PREMATURELY HARVESTS

### SCR Timer

1. Line voltage at hot gas valve?
  - No - Replace hot gas valve
2. Line voltage at NO and 2 terminals on SCR timer?
3. Line voltage at 6 & 2 on SCR timer?
  - No - Replace SCR timer.

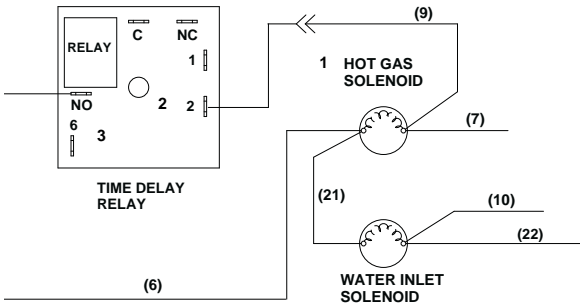

## ICE MACHINE WILL NOT HARVEST

### SCR Timer

1. Check for line voltage at terminals 1 & 2 and C & 2.  
If line voltage is not present refer to toggle switch diagnostics.

2. Check for line voltage at 2 & 6.

- No line voltage

Refer to evaporator thermostat diagnostics.

Evaporator temperature must be below setpoint.

- Line Voltage

Momentarily disconnect then reconnect power to #6.

3. Wait 11 minutes.

- Ice machine cycles into harvest - Refer to evaporator thermostat diagnostics. The evaporator thermostat must open the trigger contact (#6) to reset the freeze cycle time. If power is not broken at #6 the ice machine will remain in the freeze cycle and never initiate a harvest cycle.
- Ice machine remains in freeze - Replace timer.

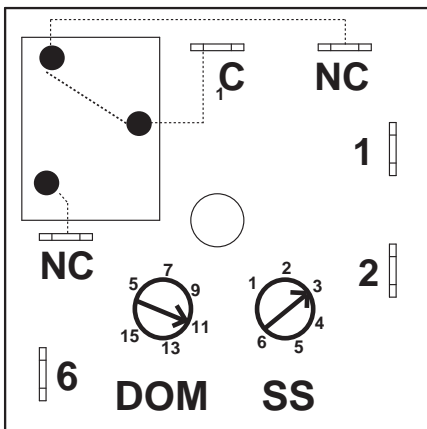

## **S.C.R. TIMER**

Silicon Rectifier (S.C.R.) Switch

### **Function**

Extends the length of the freeze cycle (after the evaporator thermostat closes), initiates and terminates the harvest cycle.

### **Settings**

**Dom** (delay on make) dial indicates minutes and determines the additional length of freeze time after the evaporator thermostat closes. Factory setting is 11 minutes

**SS** (single shot time) dial indicates minutes and determines the length of the harvest cycle. Factory setting is 3 minutes.

### **Operation**

- Total freeze cycle time = the time it takes to close the evaporator thermostat plus 10 minutes.
- Total harvest time = the setting on the timer SS dial.

### **DURING THE FREEZE CYCLE**

After the evaporator thermostat closes, the timer is supplied with power. The ice machine remains in freeze until the timer reaches the setpoint time. Contacts 6 & NO (normally open) on the timer close to supply power to the hot gas and water inlet valves.

### **DURING THE HARVEST CYCLE**

The ice machine remains in harvest until the timer reaches the setpoint time.

## LOW AMBIENT ADJUSTMENT FOR SCR TIMER

Adjust SS (single shot time) dial to 5 minutes.

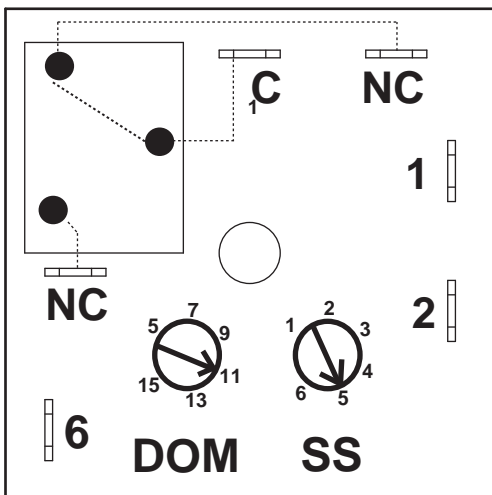

## **EVAPORATOR THERMOSTAT**

### **Function**

Mechanical Timer - Energizes the timer motor when the evaporator temperature drops below the control set point.

SCR Timer - Supplies and removes power to SCR trigger.

No Timer - Initiates and terminates freeze and harvest cycles.

### **Operation**

Thermostat contacts C & L are closed at temperatures above cut in and contacts C & H are closed at temperatures below cut in.

### **Setting Control For Proper Operation**

Correct setting will vary with operating ambient. To obtain correct setpoint, capture and weigh the ice from 1 freeze cycle (refer to ice production check for complete details).

Refer to Cycle Time/24 hour Ice Production charts for correct cube weight and quantity. White or mishappen cubes indicate cleaning is required.

## Check Procedure

1. Make sure bulb is inserted correctly (flush with end of bulb well).
2. Check evaporator temperature — is evaporator frosted?
3. Move the thermostat adjustment to the coldest and warmest setting, did the contacts change position?
4. Attach a thermocouple and measure the temperature at the bulb. At 0°C the thermostat can be adjusted warmer or colder to change contact positions. If readings do not match chart, replace the thermostat.

<b>Temperature</b>	<b>Contacts C &amp; L</b>	<b>Contacts C &amp; H</b>
Above Setpoint @ Bulb	Closed	Open
Below Setpoint @ Bulb	Open	Closed

## ON/OFF/WASH TOGGLE SWITCH

### Function

The switch is used to place the ice machine in ON, OFF or WASH mode of operation.

### Specifications

Double-pole, Double-throw switch.

### Check Procedure

1. Inspect the toggle switch for correct wiring.
2. Isolate the toggle switch by disconnecting all wires from the switch.
3. Check across the toggle switch terminals using a calibrated ohmmeter. Note where the wire numbers are connected to the switch terminals, or refer to the wiring diagram to take proper readings.

Switch Setting	Terminals	Ohm Reading
ON	5-6	Open
	5-4	Closed
	2-1	Closed
	2-3	Open
WASH	5-4	Open
	5-6	Closed
	2-3	Closed
	2-1	Open
OFF	2-3	Open
	2-1	Open
	5-6	Open
	5-4	Open

Replace the toggle switch if ohm readings do not match all three-switch settings.



## BIN THERMOSTAT

### Function

The bin thermostat stops the ice machine when the bin is full. When ice cubes contact the bin thermostat bulb holder, the bin thermostat opens and stops the ice machine. When ice cubes no longer contact the bin thermostat bulb holder, the bin thermostat closes and the ice machine starts.

### Specifications

Control	Setting
Bin Thermostat	Cut in: 4.5°C Cut out: 1.0°C

### Check Procedure



#### Warning

Disconnect electrical power to the entire ice machine before proceeding.

Make sure bulb is inserted correctly 35.5 cm in the bulb well. Disconnect the wires from the bin thermostat and check the resistance across the terminals.

No Ice on Bulb	Ice on Bulb	Result
Closed (O)	Open (OL)	Thermostat good
Open (OL)	Closed (O)	Replace thermostat

**NOTE:** After covering/uncovering the bulb holder with ice, wait at least three minutes to allow the thermostat to react. (Open/Close)

## HIGH PRESSURE CUTOUT (HPCO) CONTROL

### Water Cooled Only

#### FUNCTION

Stops the ice machine if subjected to excessive high-side pressure.

The HPCO control is normally closed, and opens on a rise in discharge pressure.



# Refrigeration Diagnostics

## TUBING SCHEMATIC

### EC18/EC20/EC30/EC40 Tubing Schematic

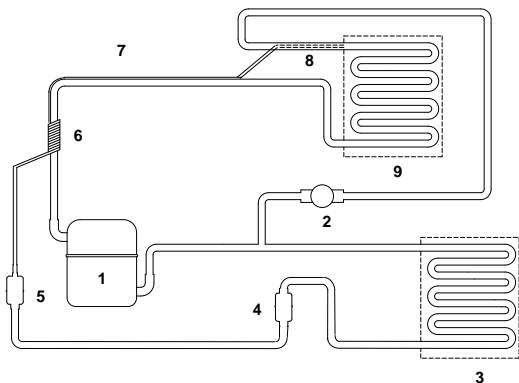

1. Compressor
2. Hot Gas Valve
3. Condenser (Air or Water Cooled)
4. Receiver (Water Cooled Only)
5. Liquid Line Drier
6. Suction Accumulator with Heat Exchanger
7. Heat Exchanger
8. Capillary Tube
9. Evaporator

## EC50/EC65/EC80 Tubing Schematic

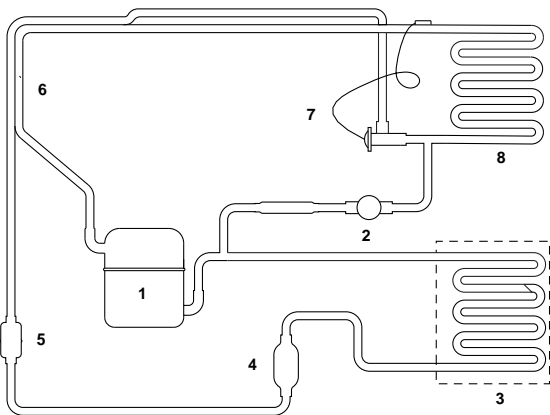

1. Compressor
2. Hot Gas Valve
3. Condenser (Air or Water Cooled)
4. Receiver (Water Cooled Only)
5. Liquid Line Drier
6. Heat Exchanger
7. Thermostatic Expansion Valve
8. Evaporator

## ICE PRODUCTION CHECK

The amount of ice a machine produces directly relates to the operating water and air temperatures. This means an ice machine with a 20°C outdoor ambient temperature and 10.0°C water produces more ice than the same model ice machine with a 32°C outdoor ambient and 21°C water.

1. Determine the ice machine operating conditions:

Air temp entering condenser: \_\_\_\_\_°

Air temp around ice machine: \_\_\_\_\_°

Water temp entering sump trough: \_\_\_\_\_°

2. Refer to the appropriate 24-Hour Ice Production Chart.
3. Use the operating conditions determined in Step 1 to find published 24 hr. ice production: \_\_\_\_\_
  - Times are in minutes.  
Example: 1 min., 15 sec. converts to 1.25 min.  
(15 seconds ÷ 60 seconds = .25 minutes)
  - Weights are in grams.
4. Perform an ice production check using the formula below.

1.	$\frac{\text{Freeze Time}}{\quad}$	+	$\frac{\text{Harvest Time}}{\quad}$	=	$\frac{\text{Total Cycle Time}}{\quad}$
2.	$\frac{1440}{\text{Minutes in 24 Hrs.}}$		$\frac{\quad}{\text{Total Cycle Time}}$		$\frac{\quad}{\text{Cycles per Day}}$
3.	$\frac{\text{Weight of One Harvest}}{\quad}$	×	$\frac{\quad}{\text{Cycles per Day}}$	=	$\frac{\quad}{\text{Actual 24-Hour Production}}$

Weighing the ice is the only 100% accurate check.

Compare the results of Step 3 with Step 2. Ice production is normal when these numbers match closely. If they match closely, determine if:

- Another ice machine is required.
- Relocating the existing equipment to lower the load conditions is required.

## **WATER SYSTEM CHECKLIST**

A water-related problem often causes the same symptoms as a refrigeration system component malfunction.

Water system problems must be identified and eliminated prior to replacing refrigeration components.

### **Water area (evaporator) is dirty**

- Clean as needed

### **Water inlet pressure not between 1.4 and 5.5 bar**

- Install a water regulator valve or increase the water pressure

### **Incoming water temperature is not between 1.7°C and 32.2°C**

- If too hot, check the hot water line check valves in other store equipment

### **Water filtration is plugged (if used)**

- Install a new water filter

### **Hoses, fittings, etc., are leaking water**

- Repair/replace as needed

### **Water inlet valve is stuck open or closed**

- Clean/replace as needed

### **Water is spraying out of the sump trough area**

- Stop the water spray

### **Uneven water flow across the evaporator**

- Clean the ice machine

## ANALYZING DISCHARGE PRESSURE

1. Determine the ice machine operating conditions:  
Air temp. entering condenser \_\_\_\_\_  
Air temp. around ice machine \_\_\_\_\_  
Water temp. entering sump trough \_\_\_\_\_
2. Refer to Cycle Times/24 Hour Ice Production/  
Refrigeration Pressure Chart for ice machine being  
checked.
3. Use the operating conditions determined in Step 1  
to find the published normal discharge pressures.  
Freeze Cycle \_\_\_\_\_  
Harvest Cycle \_\_\_\_\_

Perform an actual discharge pressure check.

	<b>Freeze Cycle PSIG</b>	<b>Harvest Cycle PSIG</b>
Beginning of Cycle	_____	_____
Middle of Cycle	_____	_____
End of Cycle	_____	_____

Compare the actual discharge pressure (Step 3) with the published discharge pressure (Step 2).

The discharge pressure is normal when the actual pressure falls within the published pressure range for the ice machine's operating conditions. It is normal for the discharge pressure to be higher at the beginning of the freeze cycle (when load is greatest), then drop throughout the freeze cycle.

## **DISCHARGE PRESSURE HIGH CHECKLIST**

### **Improper Installation**

- Refer to “Installation/Visual Inspection Checklist”

### **Restricted Condenser Air Flow**

- High inlet air temperature
- Condenser discharge air re-circulation
- Dirty condenser fins
- Defective fan motor

### **Improper Refrigerant Charge**

- Overcharged
- Non-condensable in system
- Wrong type of refrigerant

### **Other**

- High side refrigerant lines/component restricted (before mid-condenser)



## **FREEZE CYCLE DISCHARGE PRESSURE LOW CHECKLIST**

### **Improper Installation**

- Refer to “Installation/Visual Inspection Checklist”

### **Improper Refrigerant Charge**

- Undercharged
- Wrong type of refrigerant

### **Other**

- High side refrigerant lines/component restricted (before mid-condenser)

**NOTE:** Do not limit your diagnosis to only the items listed in the checklists.

## **ANALYZING SUCTION PRESSURE**

The suction pressure gradually drops throughout the freeze cycle. The actual suction pressure (and drop rate) changes as the air and water temperature entering the ice machine changes. These variables also determine the freeze cycle times.

To analyze and identify the proper suction pressure drop throughout the freeze cycle, compare the published suction pressure to the published freeze cycle time.

**NOTE:** Analyze discharge pressure before analyzing suction pressure. High or low discharge pressure may be causing high or low suction pressure.

## Procedure

Step	Example Using ECS040A Model Ice Machine									
1. Determine the ice machine operating conditions.	Air temp. entering condenser: 32°C Water temp. entering water fill valve: 21°C									
2A. Refer to "Cycle Time" and "Operating Pressure" charts for ice machine model being checked. Using operating conditions from Step 1, determine published freeze cycle time and published freeze cycle suction pressure.	<u>40 minutes</u> Published Freeze cycle time: <u>1.94 to .41 bar</u> Published Freeze cycle suction pressure:									
2B. Compare the published freeze cycle time and published freeze cycle suction pressure. Develop a chart.	<p style="text-align: center;">Published Freeze Cycle Time (minutes)</p> <table style="margin: auto; border-collapse: collapse;"> <tr> <td style="text-align: center; padding: 0 10px;">1</td> <td style="text-align: center; padding: 0 10px;">20</td> <td style="text-align: center; padding: 0 10px;">40</td> </tr> <tr> <td colspan="3" style="text-align: center;"> ----- ----- ----- </td> </tr> <tr> <td style="text-align: center; padding: 0 10px;">1.94</td> <td style="text-align: center; padding: 0 10px;">1.17</td> <td style="text-align: center; padding: 0 10px;">.41</td> </tr> </table> <p style="text-align: center;">Published Freeze Cycle Suction Pressure (bar)</p> <p>In the example, the proper suction pressure should be approximately 1.94 bar at 1 minute; 1.17 bar at 20 minutes; etc.</p>	1	20	40	----- ----- -----			1.94	1.17	.41
1	20	40								
----- ----- -----										
1.94	1.17	.41								
3. Perform an actual suction pressure check at the beginning, middle and end of the freeze cycle. Note the times at which the readings are taken.	Manifold gauges were connected to the example ice machine and suction pressure readings taken as follows: <u>Beginning of Freeze cycle:3 bar (at 1 min.)</u> <u>Middle of Freeze cycle:2 bar (at 20 min.)</u> <u>End of Freeze cycle:1 bar (at 40 min.)</u>									
4. Compare the actual freeze cycle suction pressure (Step 3) to the published freeze cycle time and pressure comparison (Step 2B). Determine if the suction pressure is high, low or acceptable.	In this example, the suction pressure is considered high throughout the freeze cycle. It should have been: Approximately 1.94 bar (at 1 minute) – not 3 bar Approximately 1.17 bar (at 20 minutes) – not 2 bar Approximately .41 bar (at 40 minutes) – not 1 bar									

## **SUCTION PRESSURE HIGH CHECKLIST**

### **Improper Installation**

- Refer to “Installation/Visual Inspection Checklist”

### **Discharge Pressure**

- Discharge pressure is too high, and is affecting suction pressure, refer to “Freeze Cycle Discharge Pressure High Checklist”

### **Improper Refrigerant Charge**

- Overcharged
- Wrong type of refrigerant
- Non Condensable in system

### **Other**

- Hot gas valve leaking
- TXV flooding (check bulb mounting)
- Defective compressor

## SUCTION PRESSURE LOW CHECKLIST

### Improper Installation

- Refer to “Installation/Visual Inspection Checklist”

### Discharge Pressure

- Discharge pressure is too low, and is affecting suction pressure, refer to “Freeze Cycle Discharge Pressure Low Checklist”

### Improper Refrigerant Charge

- Undercharged
- Wrong type of refrigerant

### Other

- Improper water supply over evaporator, refer to “Water System Checklist”
- Loss of heat transfer from tubing on back side of evaporator
- Restricted/plugged liquid line drier
- Restricted/plugged tubing or capillary tube in suction side of refrigeration system
- TXV starving
- Moisture in refrigeration system

**NOTE:** Do not limit your diagnosis to only the items listed in the checklists.

## **HOT GAS VALVE**

### **General**

The hot gas valve is an electrically operated valve that opens when energized, and closes when de-energized.

### **Normal Operation**

The valve is de-energized (closed) during the freeze cycle and energized (open) during the harvest cycle. The valve is positioned between the compressor and the evaporator and performs two functions:

1. Prevents refrigerant from entering the evaporator during the freeze cycle.

The hot gas valve is de-energized (closed) preventing refrigerant flow from the receiver into the evaporator.

2. Allows refrigerant vapor to enter the evaporator in the harvest cycle.

During the harvest cycle, the hot gas valve is energized (open) allowing refrigerant gas from the discharge line of the compressor to flow into the evaporator. The heat is absorbed by the evaporator and allows release of the ice slab.

Exact pressures vary according to ambient temperature and ice machine model. Harvest pressures can be found in the "Cycle Time/24 Hour Ice Production/Refrigerant Pressure Charts in this book.

## Hot Gas Valve Analysis

The valve can fail in two positions:

- Valve will not open in the harvest cycle.
- Valve remains open during the freeze cycle.

### VALVE WILL NOT OPEN IN THE HARVEST CYCLE:

Although the coil is energized in the harvest cycle, the evaporator temperature/pressure remains unchanged from the freeze cycle.

### VALVE REMAINS OPEN IN THE FREEZE CYCLE:

Symptoms of a hot gas valve remaining partially open during the freeze cycle can be similar to symptoms of an expansion valve, Capillary tube or compressor problem. Symptoms are dependent on the amount of leakage in the freeze cycle.

A small amount of leakage will cause increased freeze times. As the amount of leakage increases, the length of the freeze cycle increases.

Refer to the Parts Manual for proper valve application. If replacement is necessary, use only “original” Manitowoc replacement parts.

Use the following procedure and table to help determine if a hot gas valve is remaining partially open during the freeze cycle.

1. Wait five minutes into the freeze cycle.
2. Feel the inlet of the hot gas valve.

### **Important**

Feeling the hot gas valve outlet or across the hot gas valve itself will not work for this comparison. The hot gas valve outlet is on the suction side (cool refrigerant). It may be cool enough to touch even if the valve is leaking.

3. Feel the compressor discharge line.



### **Warning**

The inlet of the hot gas valve and the compressor discharge line could be hot enough to burn your hand. Just touch them momentarily.

4. Compare the temperature of the inlet of the hot gas valves to the temperature of the compressor discharge line.



## Examples of hot gas valve inlet/compressor discharge line temperature comparison

Findings	Comments
The inlet of the hot gas valve is cool enough to touch and the compressor discharge line is hot.	This is normal as the discharge line should always be too hot to touch and the hot gas valve inlet, although too hot to touch during harvest, should be cool enough to touch after 5 minutes into the freeze cycle.
The inlet of the hot gas valve is hot and approaches the temperature of a hot compressor discharge line.	This is an indication something is wrong, as the hot gas valve inlet did not cool down during the freeze cycle. If the compressor dome is also entirely hot, the problem is not a hot gas valve leaking, but rather something causing the compressor (and the entire ice machine) to get hot.
Both the inlet of the hot gas valve and the compressor discharge line are cool enough to touch.	This is an indication something is wrong, causing the compressor discharge line to be cool to the touch. This is not caused by a hot gas valve leaking.

## **DISCHARGE LINE TEMPERATURE ANALYSIS**

### **General**

Compressor discharge line temperature on a normally operating ice machine steadily increases throughout the freeze cycle. Comparing the temperatures over several cycles will result in a consistent maximum discharge line temperature.

Ambient air temperatures affect the maximum discharge line temperature.

Higher ambient air temperatures at the condenser = higher discharge line temperatures at the compressor.

Lower ambient air temperatures at the condenser = lower discharge line temperatures at the compressor.

Regardless of ambient temperature, the freeze cycle discharge line temperature will be higher than 71°C on a normally operating ice machine.

### **Procedure**

Connect a temperature probe on the compressor discharge line within 6" of the compressor.

Observe the discharge line temperature for the last ten minutes of the freeze cycle and record the maximum discharge line temperature.

*Continued next page...*

## DISCHARGE LINE TEMPERATURE ABOVE 71°C AT END OF FREEZE CYCLE:

Ice machines that are operating normally will have consistent maximum discharge line temperatures above 71°C.

## DISCHARGE LINE TEMPERATURE BELOW 71°C AT END OF FREEZE CYCLE:

Ice machines that have a flooding expansion valve will have a maximum discharge line temperature that decreases each cycle.

Verify the expansion valve sensing bulb is 100% insulated and sealed airtight. Condenser air contacting an incorrectly insulated sensing bulb will cause overfeeding of the expansion valve.

Verify the expansion valve sensing bulb is positioned and secured correctly.

## TOTAL SYSTEM REFRIGERATION CHARGE

### Important

This information is for reference only. Refer to the ice machine serial number tag to verify the system charge. Serial plate information overrides information listed on this page.

Model	Refrigerant Charge (grams)	Refrigerant Type
EC018 Air-Cooled	160 or 180	R134A
EC020 Air-Cooled	160 or 180	R134A
EC020 Water-Cooled	130 or 160	R134A
EC030 Air-Cooled	170 or 180	R134A
EC030 Water-Cooled	170	R134A
EC040 Air-Cooled	230	R134A
EC040 Water-Cooled	200	R134A
EC050 Air-Cooled	250	R134A
EC050 Water-Cooled	210	R134A
EC065 Air-Cooled	230	R404A
EC065 Water-Cooled	200	R404A
EC080 Air-Cooled	250	R404A
EC080 Water-Cooled	200	R404A

## **Cycle Times/24 Hour Ice Production and Refrigerant Pressure Charts**

These charts are used as guidelines to verify correct ice machine operation.

Accurate collection of data is essential to obtain the correct diagnosis.

- Refer to “OPERATIONAL ANALYSIS CHART” for the list of data that must be collected for refrigeration diagnostics. This list includes: before beginning service, ice production check, installation/visual inspection, water system checklist, ice formation pattern, safety limits, comparing evaporator inlet/outlet temperatures, hot gas valve analysis, discharge and suction pressure analysis.
- Ice production checks that are within 10% of the chart are considered normal. This is due to variances in water and air temperature. Actual temperatures will seldom match the chart exactly.
- Zero out manifold gauge set before obtaining pressure readings to avoid misdiagnosis.
- Discharge and suction pressure are highest at the beginning of the cycle. Suction pressure will drop throughout the cycle. Verify the pressures are within the range indicated.

## EC18 SELF-CONTAINED AIR-COOLED — MINI CUBE

**NOTE:** These characteristics may vary depending on operating conditions.

### Cycle Times

Freeze Time + Harvest Time = Total Cycle Time

Air Temp. Entering Condenser °C	Freeze Time							Harvest Time
	Water Temperature °C							
	10	15	20	25	30	35	40	
10								3.5 min.
15								
20	13.2-17.7		14.7-19.6		16.4-21.9			
25	15.1-20.1		16.4-21.9		18.6-24.7			
30	16.9-22.5		15.5-20.9		20.6-27.3			
35								
40	19.9-26.4		22.2-29.4		24.0-31.7			
45	24.0-31.7		26.1-34.5		28.6-37.8			

Times in minutes.

*Continued next page...*

## EC18 SELF-CONTAINED AIR-COOLED — MINI CUBE (Continued)

### 24 Hour Ice Production

Air Temp. Entering Condenser °C	Water Temperature °C						
	10	15	20	25	30	35	40
10							
15							
20	20		19		17		
25	18		17		15		
30	16		18		14		
35							
40	14		13		12		
45	12		11		10		

Based on average ice weight of 0.21 - 0.27 kg per cycle. Individual cube weight 8 grams  $\pm$ 1.  
Number of individual cubes per cycle: 30

*Continued next page...*

## EC18 SELF-CONTAINED AIR-COOLED — MINI CUBE (Continued)

### Operating Pressures

Air Temp. Entering Condenser °C	Freeze Cycle		Harvest Cycle	
	Discharge Pressure	Suction Pressure	Discharge Pressure	Suction Pressure
10	6.55-4.48	1.10-0.14	3.10-4.14	2.07-3.10
20	9.31-6.89	1.24-0.28	4.48-5.52	3.10-4.14
25	10.69-7.24	1.38-0.28	4.83-6.55	3.79-4.48
32	17.24-12.07	1.72-0.34	6.20-8.27	4.13-5.86
43	19.30-13.10	2.10-0.34	7.58-10.69	4.13-7.58

All pressures are in bar. Suction pressure drops gradually throughout the freeze cycle.



## EC18 SELF-CONTAINED AIR-COOLED — STANDARD CUBE

**NOTE:** These characteristics may vary depending on operating conditions.

### Cycle Times

Freeze Time + Harvest Time = Total Cycle Time

Air Temp. Entering Condenser °C	Freeze Time							Harvest Time
	Water Temperature °C							
	10	15	20	25	30	35	40	
10	19.1-21.4							3.5 min.
15	19.7-22.1	19.8-22.2						
20	21.2-23.8	21.4-23.9	21.5-24.1	21.7-24.3	21.4-23.9			
25	22.8-25.5	24.0-26.8	23.3-26.0	23.4-26.2	23.6-26.4			
30	24.7-27.6	24.9-27.8	25.1-28.1	25.3-28.3	25.7-28.7	25.9-29.0	26.1-29.2	
35			27.7-30.9	27.7-30.9	27.9-31.1	28.1-31.4	28.6-31.9	
40					30.7-34.3	31.0-34.6	31.3-34.9	
45					34.1-38.0	34.6-38.4	34.8-38.8	

Times in minutes.

*Continued next page...*

## EC18 SELF-CONTAINED AIR-COOLED — STANDARD CUBE (Continued)

### 24 Hour Ice Production

Air Temp. Entering Condenser °C	Water Temperature °C						
	10	15	20	25	30	35	40
10	18.5						
15	18.0	17.9					
20	16.9	16.8	16.7	16.6	16.8		
25	15.9	15.2	15.6	15.5	15.4		
30	14.8	14.7	14.6	14.5	14.3	14.2	14.1
35			13.4	13.4	13.3	13.2	13.0
40					12.2	12.1	12.0
45					11.1	11.0	10.9

Based on average ice weight of 0.29 - 0.32 kg per cycle. Individual cube weight 19 grams ±1.  
Number of individual cubes per cycle: 16

*Continued next page...*

## EC18 SELF-CONTAINED AIR-COOLED — STANDARD CUBE (Continued)

### Operating Pressures

Air Temp. Entering Condenser °C	Freeze Cycle		Harvest Cycle	
	Discharge Pressure	Suction Pressure	Discharge Pressure	Suction Pressure
10	6.55-4.48	1.10-0.14	3.10-4.14	2.07-3.10
20	9.31-6.89	1.24-0.28	4.48-5.52	3.10-4.14
25	10.69-7.24	1.38-0.34	4.83-6.55	3.79-4.48
32	13.10-9.31	1.72-0.55	6.20-8.27	5.17-5.86
43	17.24-12.07	1.72-0.69	7.58-10.69	6.21-7.58

All pressures are in bar. Suction pressure drops gradually throughout the freeze cycle.

## EC20 (WITH TIMER) SELF-CONTAINED AIR-COOLED — STANDARD CUBE

**NOTE:** These characteristics may vary depending on operating conditions.

### Cycle Times

Freeze Time + Harvest Time = Total Cycle Time

Air Temp. Entering Condenser °C	Freeze Time							Harvest Time
	Water Temperature °C							
	10	15	20	25	30	35	40	
10	18.6-21.2							3.5 min.
15	20.3-23.1	21.3-24.1						
20	22.3-25.3	24.6-27.9	26.0-29.4	27.5-31.1	30.9-34.9			
25	26.0-29.4	27.5-31.1	29.1-32.9	32.9-37.2	35.2-39.7			
30	29.1-32.9	30.9-34.9	35.2-39.7	37.8-42.6	40.7-45.9	48.1-54.1	52.8-59.3	
35			40.7-45.9	44.1-49.7	52.8-59.3	58.4-65.6	65.3-75.3	
40					65.3-73.3	73.9-82.9	99.7-111.7	
45					85.0-95.2	120.3-134.7	151.3-169.3	

Times in minutes.

*Continued next page...*

## EC20 (WITH TIMER) SELF-CONTAINED AIR-COOLED — STANDARD CUBE (Continued)

### 24 Hour Ice Production

Air Temp. Entering Condenser °C	Water Temperature °C						
	10	15	20	25	30	35	40
10	28						
15	26	25					
20	24	22	21	20	18		
25	21	20	19	17	16		
30	19	18	16	15	14	12	11
35			14	13	11	10	9
40					9	8	6
45					7	5	4

Based on average ice weight of 0.43 - 0.48 kg per cycle. Individual cube weight 19 grams  $\pm$ 1.  
Number of individual cubes per cycle: 24

*Continued next page...*

## EC20 (WITH TIMER) SELF-CONTAINED AIR-COOLED — STANDARD CUBE (Continued)

### Operating Pressures

Air Temp. Entering Condenser °C	Freeze Cycle		Harvest Cycle	
	Discharge Pressure	Suction Pressure	Discharge Pressure	Suction Pressure
10	7.24-4.83	1.38-0	2.76-3.45	1.72-2.76
20	11.38-6.89	1.72-0.34	3.45-5.51	2.76-4.14
43	20.68-13.79	2.76-0.69	4.14-9.30	4.14-6.89

All pressures are in bar. Suction pressure drops gradually throughout the freeze cycle.

## EC20 (WITH TIMER) SELF-CONTAINED AIR-COOLED — LARGE CUBE

**NOTE:** These characteristics may vary depending on operating conditions.

### Cycle Times

Freeze Time + Harvest Time = Total Cycle Time

Air Temp. Entering Condenser °C	Freeze Time							Harvest Time
	Water Temperature °C							
	10	15	20	25	30	35	40	
10	24.5-26.4							3.5 min.
15	28.8-31.0	29.8-32.1						
20	32.0-34.4	33.2-35.7	34.6-37.1	36.0-38.6	37.5-40.3			
25	37.5-40.3	44.9-48.2	39.1-42.0	40.9-43.9	42.8-46.0			
30	42.8-46.0	44.9-48.2	47.2-50.7	47.2-50.7	49.8-53.4	52.6-56.4	55.7-59.7	
35			55.7-59.7	59.2-63.4	63.1-67.6	63.1-67.6	67.5-72.3	
40					78.5-84.0	85.3-91.3	93.4-99.9	
45					103.1-110.3	114.9-122.9	129.7-138.0	

Times in minutes.

*Continued next page...*

## EC20 (WITH TIMER) SELF-CONTAINED AIR-COOLED — LARGE CUBE (Continued)

### 24 Hour Ice Production

Air Temp. Entering Condenser °C	Water Temperature °C						
	10	15	20	25	30	35	40
10	38						
15	33	32					
20	30	29	28	27	26		
25	26	22	25	24	23		
30	23	22	21	21	20	19	18
35			18	17	16	16	15
40					13	12	11
45					10	9	8

Based on average ice weight of 0.74 - 0.79 kg per cycle. Individual cube weight 32 grams ±1.  
Number of individual cubes per cycle: 24

*Continued next page...*



## EC20 (WITH TIMER) SELF-CONTAINED AIR-COOLED — LARGE CUBE (Continued)

### Operating Pressures

Air Temp. Entering Condenser °C	Freeze Cycle		Harvest Cycle	
	Discharge Pressure	Suction Pressure	Discharge Pressure	Suction Pressure
10	8.96-6.89	1.72-0	2.76-5.51	1.72-4.14
20	11.03-7.93	2.07-0	2.76-6.89	2.76-5.51
43	8.27-12.41	2.07-0.69	3.10-7.58	3.10-7.58

All pressures are in bar. Suction pressure drops gradually throughout the freeze cycle.

## EC20 (WITHOUT TIMER) SELF-CONTAINED AIR-COOLED — MINI CUBE

**NOTE:** These characteristics may vary depending on operating conditions.

### Cycle Times

Freeze Time + Harvest Time = Total Cycle Time

Air Temp. Entering Condenser °C	Freeze Time							Harvest Time
	Water Temperature °C							
	10	15	20	25	30	35	40	
10								3.5 min.
15								
20	15.5-20.7		16.9-22.5		18.6-24.7			
25	18.0-23.9		19.2-25.5		20.6-27.3			
30	20.6-27.3		18.0-23.9		23.0-30.5			
35								
40	25.0-33.1		26.1-34.5		26.1-34.5			
45	31.6-41.7		30.0-39.6		30.0-39.6			

Times in minutes.

*Continued next page...*

## EC20 (WITHOUT TIMER) SELF-CONTAINED AIR-COOLED — MINI (Continued)

### 24 Hour Ice Production

Air Temp. Entering Condenser °C	Water Temperature °C						
	10	15	20	25	30	35	40
10							
15							
20	18		16		15		
25	15		15		14		
30	14		15		12		
35							
40	11		11		11		
45	9.		10		105		

Based on average ice weight of 0.21 - 0.27 kg per cycle. Individual cube weight 8 grams  $\pm$ 1.  
Number of individual cubes per cycle: 30

*Continued next page...*

## EC20 (WITHOUT TIMER) SELF-CONTAINED AIR-COOLED — MINI CUBE (Continued)

### Operating Pressures

Air Temp. Entering Condenser °C	Freeze Cycle		Harvest Cycle	
	Discharge Pressure	Suction Pressure	Discharge Pressure	Suction Pressure
10	5.51-4.13	1.03-.13	3.10-3.79	1.65-2.75
20	9.65-5.86	1.72-.27	4.82-6.20	2.75-4.82
25	10.34-7.58	1.72-.34	5.51-6.55	2.75-4.82
32	12.41-9.30	1.72-.34	8.61-9.65	2.75-5.86
43	17.92-13.79	2.76-0.69	8.96-11.03	4.14-6.89

All pressures are in bar. Suction pressure drops gradually throughout the freeze cycle.

## EC20 (WITHOUT TIMER) SELF-CONTAINED AIR-COOLED — STANDARD CUBE

**NOTE:** These characteristics may vary depending on operating conditions.

### Cycle Times

Freeze Time + Harvest Time = Total Cycle Time

Air Temp. Entering Condenser °C	Freeze Time							Harvest Time
	Water Temperature °C							
	10	15	20	25	30	35	40	
10	19.1-21.4							3.5 min.
15	19.7-22.1	19.8-22.2						
20	21.2-23.8	21.4-23.9	21.5-24.1	21.7-24.3	21.4-23.9			
25	22.8-25.5	24.0-26.8	23.3-26.0	23.4-26.2	23.6-26.4			
30	24.7-27.6	24.9-27.8	25.1-28.1	25.3-28.3	25.7-28.7	25.9-29.0	26.1-29.2	
35			27.7-30.9	27.7-30.9	27.9-31.1	28.1-31.4	28.6-31.9	
40					30.7-34.3	31.0-34.6	31.3-34.9	
45					34.1-38.0	34.6-38.4	34.8-38.8	

Times in minutes.

*Continued next page...*

## EC20 (WITHOUT TIMER) SELF-CONTAINED AIR-COOLED — STANDARD CUBE (Continued)

### 24 Hour Ice Production

Air Temp. Entering Condenser °C	Water Temperature °C						
	10	15	20	25	30	35	40
10	18.5						
15	18.0	17.9					
20	16.9	16.8	16.7	16.6	16.8		
25	15.9	15.2	15.6	15.5	15.4		
30	14.8	14.7	14.6	14.5	14.3	14.2	14.1
35			13.4	13.4	13.3	13.2	13.0
40					12.2	12.1	12.0
45					11.1	11.0	10.9

Based on average ice weight of 0.29 - 0.32 kg per cycle. Individual cube weight 19 grams ±1.  
Number of individual cubes per cycle: 16

*Continued next page...*

## EC20 (WITHOUT TIMER) SELF-CONTAINED AIR-COOLED — STANDARD CUBE (Continued)

### Operating Pressures

Air Temp. Entering Condenser °C	Freeze Cycle		Harvest Cycle	
	Discharge Pressure	Suction Pressure	Discharge Pressure	Suction Pressure
10	6.55-4.48	1.10-0.14	3.10-4.14	2.07-3.10
20	9.31-6.89	1.24-0.28	4.48-5.52	3.10-4.14
25	10.69-7.24	1.38-0.34	4.83-6.55	3.79-4.48
32	13.10-9.31	1.72-0.55	6.20-8.27	5.17-5.86
43	17.24-12.07	1.72-0.69	7.58-10.69	6.21-7.58

All pressures are in bar. Suction pressure drops gradually throughout the freeze cycle.

## EC30 SELF-CONTAINED AIR-COOLED — STANDARD CUBE

**NOTE:** These characteristics may vary depending on operating conditions.

### Cycle Times

Freeze Time + Harvest Time = Total Cycle Time

Air Temp. Entering Condenser °C	Freeze Time							Harvest Time
	Water Temperature °C							
	10	15	20	25	30	35	40	
10	16.5-18.8							3.5 min.
15	18.6-21.2	19.4-22.1						
20	20.3-23.1	21.3-24.1	23.4-26.6	24.6-27.9	26.0-29.4			
25	23.4-26.6	24.6-27.9	26.0-26.9	27.5-31.1	30.9-34.9			
30	26.0-29.4	27.5-31.1	30.9-34.9	32.9-37.2	35.2-39.7	37.8-42.6	44.1-49.7	
35			35.2-39.7	37.8-42.6	44.1-49.7	48.1-54.1	52.8-59.3	
40					52.8-59.3	58.4-65.6	65.3-73.3	
45					65.3-73.3	85.0-95.2	99.7-111.7	

Times in minutes.

*Continued next page...*



## EC30 SELF-CONTAINED AIR-COOLED — STANDARD CUBE (Continued)

### 24 Hour Ice Production

Air Temp. Entering Condenser °C	Water Temperature °C						
	10	15	20	25	30	35	40
10	31						
15	28	27					
20	26	25	23	22	21		
25	23	22	21	20	18		
30	21	20	18	17	16	15	13
35			16	15	13	12	11
40					11	10	9
45					9	7	6

Based on average ice weight of 0.43 - 0.48 kg per cycle. Individual cube weight 19 grams  $\pm$ 1.  
Number of individual cubes per cycle: 24

*Continued next page...*

## EC30 SELF-CONTAINED AIR-COOLED — STANDARD CUBE (Continued)

### Operating Pressures

Air Temp. Entering Condenser °C	Freeze Cycle		Harvest Cycle	
	Discharge Pressure	Suction Pressure	Discharge Pressure	Suction Pressure
10	9.65-5.17	1.38-0	2.16-4.48	1.72-3.10
20	15.86-7.58	2.07-0	4.14-6.55	2.76-4.83
43	25.51-14.48	2.76-0.69	4.14-10.0	4.83-8.27

All pressures are in bar. Suction pressure drops gradually throughout the freeze cycle.

## EC30 SELF-CONTAINED AIR-COOLED — LARGE CUBE

**NOTE:** These characteristics may vary depending on operating conditions.

### Cycle Times

Freeze Time + Harvest Time = Total Cycle Time

Air Temp. Entering Condenser °C	Freeze Time							Harvest Time
	Water Temperature °C							
	10	15	20	25	30	35	40	
10	26.1-28.1							3.5 min.
15	28.8-31.0	29.8-32.1						
20	33.2-35.7	34.6-37.1	36.0-38.6	36.0-38.6	37.5-40.3			
25	39.1-42.0	40.9-43.9	40.9-43.9	42.8-46.0	44.9-48.2			
30	47.2-50.7	47.2-50.7	49.8-53.4	52.6-56.4	55.7-59.7	55.7-59.7	59.2-63.4	
35			63.1-67.6	67.5-72.3	67.5-72.3	72.6-77.8	78.5-84.0	
40					93-4-99.9	103.1-110.3	114.9-122.9	
45					148.7-159.0	174.1-186.1	174.1-186.1	

Times in minutes.

*Continued next page...*

## EC30 SELF-CONTAINED AIR-COOLED — LARGE CUBE (Continued)

### 24 Hour Ice Production

Air Temp. Entering Condenser °C	Water Temperature °C						
	10	15	20	25	30	35	40
10	36						
15	33	32					
20	29	28	27	27	26		
25	25	24	24	23	22		
30	21	21	20	19	18	18	17
35			16	15	15	14	13
40					11	10	9
45					7	6	6

Based on average ice weight of 0.74 - 0.79 kg per cycle. Individual cube weight 32 grams  $\pm$ 1.  
Number of individual cubes per cycle: 24

*Continued next page...*

## EC30 SELF-CONTAINED AIR-COOLED — LARGE CUBE (Continued)

### Operating Pressures

Air Temp. Entering Condenser °C	Freeze Cycle		Harvest Cycle	
	Discharge Pressure	Suction Pressure	Discharge Pressure	Suction Pressure
10	9.65-5.17	1.38-0	2.16-4.48	1.72-3.10
20	15.86-7.58	2.07-0	4.14-6.55	2.76-4.83
43	25.51-14.48	2.76-0.69	4.14-10.0	4.83-8.27

All pressures are in bar. Suction pressure drops gradually throughout the freeze cycle.

## EC30 (SERIAL BREAK NOT AVAILABLE) SELF-CONTAINED AIR-COOLED — STANDARD CUBE

**NOTE:** These characteristics may vary depending on operating conditions.

### Cycle Times

Freeze Time + Harvest Time = Total Cycle Time

Air Temp. Entering Condenser °C	Freeze Time							Harvest Time
	Water Temperature °C							
	10	15	20	25	30	35	40	
10	18.6-21.2							3.5 min.
15	20.3-23.1	21.3-24.1						
20	22.3-25.3	24.6-27.9	26.0-29.4	27.5-31.1	30.9-34.9			
25	26.0-29.4	27.5-31.1	29.1-32.9	32.9-37.2	35.2-39.7			
30	29.1-32.9	30.9-34.9	35.2-39.7	37.8-42.6	40.7-45.9	48.1-54.1	52.8-59.3	
35			40.7-45.9	44.1-49.7	52.8-59.3	58.4-65.6	65.3-75.3	
40					65.3-73.3	73.9-82.9	99.7-111.7	
45					85.0-95.2	120.3-134.7	151.3-169.3	

Times in minutes.

*Continued next page...*

## EC30 (SERIAL BREAK NOT AVAILABLE) SELF-CONTAINED AIR-COOLED — STANDARD CUBE (Cont.)

### 24 Hour Ice Production

Air Temp. Entering Condenser °C	Water Temperature °C						
	10	15	20	25	30	35	40
10	28						
15	26	25					
20	24	22	21	20	18		
25	21	20	19	17	16		
30	19	18	16	15	14	12	11
35			14	13	11	10	9
40					9	8	6
45					7	5	4

Based on average ice weight of 0.43 - 0.48 kg per cycle. Individual cube weight 19 grams  $\pm$ 1.  
Number of individual cubes per cycle: 24

*Continued next page...*

## EC30 (SERIAL BREAK NOT AVAILABLE) SELF-CONTAINED AIR-COOLED — STANDARD CUBE (Cont.)

### Operating Pressures

Air Temp. Entering Condenser °C	Freeze Cycle		Harvest Cycle	
	Discharge Pressure	Suction Pressure	Discharge Pressure	Suction Pressure
10	7.24-4.83	1.38-0	2.76-3.45	1.72-2.76
20	11.38-6.89	1.72-0.34	3.45-5.51	2.76-4.14
43	20.68-13.79	2.76-0.69	4.14-9.30	4.14-6.89

All pressures are in bar. Suction pressure drops gradually throughout the freeze cycle.



## EC30 (SERIAL BREAK NOT AVAILABLE) SELF-CONTAINED AIR-COOLED — LARGE CUBE

**NOTE:** These characteristics may vary depending on operating conditions.

### Cycle Times

Freeze Time + Harvest Time = Total Cycle Time

Air Temp. Entering Condenser °C	Freeze Time							Harvest Time
	Water Temperature °C							
	10	15	20	25	30	35	40	
10	24.5-26.4							3.5 min.
15	28.8-31.0	29.8-32.1						
20	32.0-34.4	33.2-35.7	34.6-37.1	36.0-38.6	37.5-40.3			
25	37.5-40.3	44.9-48.2	39.1-42.0	40.9-43.9	42.8-46.0			
30	42.8-46.0	44.9-48.2	47.2-50.7	47.2-50.7	49.8-53.4	52.6-56.4	55.7-59.7	
35			55.7-59.7	59.2-63.4	63.1-67.6	63.1-67.6	67.5-72.3	
40					78.5-84.0	85.3-91.3	93.4-99.9	
45					103.1-110.3	114.9-122.9	129.7-138.0	

Times in minutes.

*Continued next page...*

# EC30 (SERIAL BREAK NOT AVAILABLE) SELF-CONTAINED AIR-COOLED — LARGE CUBE (Continued)

## 24 Hour Ice Production

Air Temp. Entering Condenser °C	Water Temperature °C						
	10	15	20	25	30	35	40
10	38						
15	33	32					
20	30	29	28	27	26		
25	26	22	25	24	23		
30	23	22	21	21	20	19	18
35			18	17	16	16	15
40					13	12	11
45					10	9	8

Based on average ice weight of 0.74 - 0.79 kg per cycle. Individual cube weight 32 grams ±1.  
Number of individual cubes per cycle: 24

*Continued next page...*

## EC30 (SERIAL BREAK NOT AVAILABLE) SELF-CONTAINED AIR-COOLED — LARGE CUBE (Continued)

### Operating Pressures

Air Temp. Entering Condenser °C	Freeze Cycle		Harvest Cycle	
	Discharge Pressure	Suction Pressure	Discharge Pressure	Suction Pressure
10	8.96-6.89	1.72-0	2.76-5.51	1.72-4.14
20	11.03-7.93	2.07-0	2.76-6.89	2.76-5.51
43	8.27-12.41	2.07-0.69	3.10-7.58	3.10-7.58

All pressures are in bar. Suction pressure drops gradually throughout the freeze cycle.

## EC40 SELF-CONTAINED AIR-COOLED — STANDARD CUBE

**NOTE:** These characteristics may vary depending on operating conditions.

### Cycle Times

Freeze Time + Harvest Time = Total Cycle Time

Air Temp. Entering Condenser °C	Freeze Time							Harvest Time
	Water Temperature °C							
	10	15	20	25	30	35	40	
10	21.8-24.6							3.5 min.
15	23.1-26.0	24.5-27.6						
20	25.3-28.5	27.0-30.4	27.9-31.4	29.9-33.7	34.9-39.2			
25	27.9-31.4	29.9-33.7	31.1-34.9	33.5-37.6	36.4-40.8			
30	31.1-34.9	33.5-37.6	36.4-40.8	38.0-42.6	41.6-46.6	43.6-48.9	48.3-54.1	
35			41.6-46.6	43.6-48.9	48.3-54.1	54.1-60.5	57.5-64.3	
40					57.5-64.3	65.6-73.3	70.6-78.8	
45					70.6-78.8	82.9-92.5	90.8-101.2	

Times in minutes.

*Continued next page...*

## EC40 SELF-CONTAINED AIR-COOLED — STANDARD CUBE (Continued)

### 24 Hour Ice Production

Air Temp. Entering Condenser °C	Water Temperature °C						
	10	15	20	25	30	35	40
10	41						
15	39	37					
20	36	34	33	31	27		
25	33	31	30	28	26		
30	30	28	26	25	23	22	20
35			23	22	20	18	17
40					17	15	14
45					14	12	11

Based on average ice weight of 0.72 - 0.80 kg per cycle. Individual cube weight 19 grams  $\pm$ 1.  
Number of individual cubes per cycle: 40

*Continued next page...*

## EC40 SELF-CONTAINED AIR-COOLED — STANDARD CUBE (Continued)

### Operating Pressures

Air Temp. Entering Condenser °C	Freeze Cycle		Harvest Cycle	
	Discharge Pressure	Suction Pressure	Discharge Pressure	Suction Pressure
10	7.58-4.48	1.72-.14	2.41-4.14	1.38-2.07
20	11.03-5.86	1.94-.28	3.45-5.87	1.72-3.45
25	13.10-7.24	1.94-.34	3.79-6.55	2.07-4.14
32	15.86-9.31	1.94-.41	4.82-8.27	2.76-4.82
43	21.37-11.72	2.34-.48	5.17-11.72	3.45-7.93

All pressures are in bar. Suction pressure drops gradually throughout the freeze cycle.

## EC40 SELF-CONTAINED AIR-COOLED — LARGE CUBE

**NOTE:** These characteristics may vary depending on operating conditions.

### Cycle Times

Freeze Time + Harvest Time = Total Cycle Time

Air Temp. Entering Condenser °C	Freeze Time							Harvest Time
	Water Temperature °C							
	10	15	20	25	30	35	40	
10	28.4-30.4							3.5 min.
15	30.2-32.4	32.2-34.5						
20	32.9-35.3	34.5-36.9	37.1-39.7	39.0-41.8	41.1-44.0			
25	35.3-37.8	37.1-39.7	40.1-42.9	43.5-46.5	46.1-49.3			
30	39.0-41.8	41.1-44.0	44.8-47.9	49.0-52.4	52.3-55.9	58.1-62.0	62.6-66.9	
35			50.6-54.1	54.1-57.8	60.3-64.4	65.2-69.6	74.1-79.1	
40					67.9-72.5	77.7-82.9	85.8-91.5	
45					81.5-87.0	90.5-96.5	108.1-115.3	

Times in minutes.

*Continued next page...*

## EC40 SELF-CONTAINED AIR-COOLED — LARGE CUBE (Continued)

### 24 Hour Ice Production

Air Temp. Entering Condenser °C	Water Temperature °C						
	10	15	20	25	30	35	40
10	56						
15	53	50					
20	49	47	44	42	40		
25	46	44	41	38	36		
30	42	40	37	34	32	29	27
35			33	31	28	26	23
40					25	22	20
45					21	19	16

Based on average ice weight of 1.24 - 1.32 kg per cycle. Individual cube weight 32 grams  $\pm$ 1.  
Number of individual cubes per cycle: 40

*Continued next page...*



## EC40 SELF-CONTAINED AIR-COOLED — LARGE CUBE (Continued)

### Operating Pressures

Air Temp. Entering Condenser °C	Freeze Cycle		Harvest Cycle	
	Discharge Pressure	Suction Pressure	Discharge Pressure	Suction Pressure
10	7.58-4.48	1.72-.14	2.41-4.14	1.38-2.07
20	11.03-5.86	1.94-.28	3.45-5.87	1.72-3.45
25	13.10-7.24	1.94-.34	3.79-6.55	2.07-4.14
32	15.86-9.31	1.94-.41	4.82-8.27	2.76-4.82
43	21.37-11.72	2.34-.48	5.17-11.72	3.45-7.93

All pressures are in bar. Suction pressure drops gradually throughout the freeze cycle.

## EC40 SELF-CONTAINED WATER-COOLED — STANDARD CUBE

**NOTE:** These characteristics may vary depending on operating conditions.

### Cycle Times

Freeze Time + Harvest Time = Total Cycle Time

Air Temp. Around Ice Machine °C	Freeze Time							Harvest Time
	Water Temperature °C							
	10	15	20	25	30	35	40	
10	21.8-24.6							3.5 min.
15	23.1-26.0	24.5-27.6						
20	24.5-27.6	26.1-29.4	27.9-31.4	29.9-33.7	33.5-37.6			
25	25.3-28.5	27.9-31.4	29.9-33.7	32.3-36.2	34.9-39.2			
30	27.0-30.4	28.9-32.5	31.1-34.9	33.5-37.6	36.4-40.8	41.6-46.6	45.9-51.4	
35			33.5-37.6	36.4-40.8	39.7-44.5	43.6-48.9	48.3-54.1	
40					41.6-46.6	48.3-54.1	54.1-60.5	
45					45.9-51.4	51.1-57.1	57.5-64.3	

Times in minutes.

*Continued next page...*

## EC40 SELF-CONTAINED WATER-COOLED — STANDARD CUBE (Continued)

### 24 Hour Ice Production

Air Temp. Around Ice Machine °C	Water Temperature °C						
	10	15	20	25	30	35	40
10	41						
15	39	37					
20	37	35	33	31	28		
25	36	33	31	29	27		
30	34	32	30	28	26	23	21
35			28	26	24	22	20
40					23	20	18
45					21	19	17

Based on average ice weight of 0.72 - 0.80 kg per cycle. Individual cube weight 19 grams  $\pm$ 1.  
Number of individual cubes per cycle: 40

*Continued next page...*

## EC40 SELF-CONTAINED WATER-COOLED — STANDARD CUBE (Continued)

Condenser Water Consumption	32 Air Temperature Around Ice Machine		
	Water Temperature °C		
	15	21	32
Gal/24 Hours	478	744	2283

Water regulating valve set to maintain 9 bar discharge pressure.

### Operating Pressures

Water Temperature Entering Condenser °C	Freeze Cycle		Harvest Cycle	
	Discharge Pressure	Suction Pressure	Discharge Pressure	Suction Pressure
10	10.34-8.62	1.79-.28	3.10-5.87	2.07-3.45
20	11.03-8.62	1.79-.34	3.10-7.24	2.07-4.82
25	11.03-8.62	1.79-.41	3.10-7.24	2.07-4.82
32	11.03-8.62	2.00-.41	3.10-7.24	2.07-4.82
43	11.72-8.62	2.00-.48	3.45-8.62	2.07-5.87

Set water regulating valve to 9 bar 5 minutes into freeze cycle.  
All pressures are in bar.  
Suction pressure drops gradually throughout the freeze cycle.

## EC40 SELF-CONTAINED WATER-COOLED — LARGE CUBE

**NOTE:** These characteristics may vary depending on operating conditions.

### Cycle Times

Freeze Time + Harvest Time = Total Cycle Time

Air Temp. Around Ice Machine °C	Freeze Time							Harvest Time
	Water Temperature °C							
	10	15	20	25	30	35	40	
10	30.8-33.1							3.5 min.
15	32.2-34.5	34.5-36.9						
20	33.7-36.1	35.3-37.8	38.0-40.7	41.1-44.0	44.8-47.9			
25	34.5-36.9	39.0-41.8	40.1-42.9	43.5-46.5	47.5-50.8			
30	36.2-38.7	39.0-41.8	42.3-45.2	46.1-49.3	50.6-54.1	56.0-59.9	62.6-66.9	
35			44.8-47.9	49.0-52.4	52.3-55.9	58.1-62.0	65.2-69.6	
40					56.0-59.9	62.6-66.9	70.9-75.7	
45					60.3-64.4	67.9-72.5	77.7-82.9	

Times in minutes.

*Continued next page...*

## EC40 SELF-CONTAINED WATER-COOLED — LARGE CUBE (Continued)

### 24 Hour Ice Production

Air Temp. Around Ice Machine °C	Water Temperature °C						
	10	15	20	25	30	35	40
10	52						
15	50	47					
20	48	46	43	40	37		
25	47	42	41	38	35		
30	45	42	39	36	33	30	27
35			37	34	32	29	26
40					30	27	24
45					28	25	22

Based on average ice weight of 1.24 - 1.32 kg per cycle. Individual cube weight 32 grams ±1.  
Number of individual cubes per cycle: 40

*Continued next page...*

## EC40 SELF-CONTAINED WATER-COOLED — LARGE CUBE (Continued)

Condenser Water Consumption	32 Air Temperature Around Ice Machine		
	Water Temperature °C		
	15	21	32
Gal/24 Hours	563	739	2474

Water regulating valve set to maintain 9 bar discharge pressure.

## Operating Pressures

Water Temperature Entering Condenser °C	Freeze Cycle		Harvest Cycle	
	Discharge Pressure	Suction Pressure	Discharge Pressure	Suction Pressure
10	10.34-8.62	1.79-.28	3.10-5.87	2.07-3.45
20	11.03-8.62	1.79-.34	3.10-7.24	2.07-4.82
25	11.03-8.62	1.79-.41	3.10-7.24	2.07-4.82
32	11.03-8.62	2.00-.41	3.10-7.24	2.07-4.82
43	11.72-8.62	2.00-.48	3.45-8.62	2.07-5.87

Set water regulating valve to 9 bar 5 minutes into freeze cycle. All pressures are in bar. Suction pressure drops gradually throughout the freeze cycle.

## EC50 SELF-CONTAINED AIR-COOLED — STANDARD CUBE

**NOTE:** These characteristics may vary depending on operating conditions.

### Cycle Times

Freeze Time + Harvest Time = Total Cycle Time

Air Temp. Entering Condenser °C	Freeze Time							Harvest Time
	Water Temperature °C							
	10	15	20	25	30	35	40	
10	18.1-20.5							3.5 min.
15	19.5-22.1	20.1-22.7						
20	20.6-23.3	21.8-24.6	23.1-26.0	23.8-26.8	25.3-28.5			
25	22.4-25.3	23.8-26.8	24.5-27.6	26.1-29.4	27.0-30.4			
30	24.5-27.6	25.3-28.5	27.0-30.4	27.9-31.4	29.9-33.7	32.3-36.2	33.5-37.6	
35			28.9-32.5	31.1-34.9	33.5-37.6	34.9-39.2	38.0-42.6	
40					36.4-40.8	39.7-44.5	41.6-46.6	
45					41.6-46.6	43.6-48.9	48.3-54.1	

Times in minutes.

*Continued next page...*



## EC50 SELF-CONTAINED AIR-COOLED — STANDARD CUBE (Continued)

### 24 Hour Ice Production

Air Temp. Entering Condenser °C	Water Temperature °C						
	10	15	20	25	30	35	40
10	48						
15	45	44					
20	43	41	39	38	36		
25	40	38	37	35	34		
30	37	36	34	33	31	29	28
35			32	30	28	27	25
40					26	24	23
45					23	22	20

Based on average ice weight of 0.72 - 0.80 kg per cycle. Individual cube weight 19 grams  $\pm$ 1.  
Number of individual cubes per cycle: 40

*Continued next page...*

## EC50 SELF-CONTAINED AIR-COOLED — STANDARD CUBE (Continued)

### Operating Pressures

Air Temp. Entering Condenser °C	Freeze Cycle		Harvest Cycle	
	Discharge Pressure	Suction Pressure	Discharge Pressure	Suction Pressure
10	9.31-4.48	2.76-.14	2.76-4.83	1.38-2.76
20	14.48-6.21	3.31-.14	4.14-7.58	1.72-4.48
25	14.48-7.58	3.45-.14	4.82-8.27	2.07-4.82
32	17.23-8.96	3.79-.14	6.21-9.65	2.76-5.87
43	24.13-12.07	4.27-.21	7.93-12.76	3.45-7.93

All pressures are in bar. Suction pressure drops gradually throughout the freeze cycle.

## EC50 SELF-CONTAINED AIR-COOLED — LARGE CUBE

**NOTE:** These characteristics may vary depending on operating conditions.

### Cycle Times

Freeze Time + Harvest Time = Total Cycle Time

Air Temp. Entering Condenser °C	Freeze Time							Harvest Time
	Water Temperature °C							
	10	15	20	25	30	35	40	
10	24.8-26.7							3.5 min.
15	26.8-28.7	27.8-29.8						
20	29.0-31.1	30.2-32.4	31.5-33.8	32.2-34.5	33.7-36.1			
25	31.5-33.8	32.9-35.3	33.7-36.1	35.3-37.8	37.1-39.7			
30	34.5-36.9	36.2-38.7	37.1-39.7	39.0-41.8	41.1-44.0	43.5-46.5	46.1-49.3	
35			41.1-44.0	43.5-46.5	46.1-49.3	49.0-52.4	52.3-55.9	
40					52.3-55.9	56.0-59.9	60.3-64.4	
45					60.3-64.4	65.2-69.6	70.9-75.7	

Times in minutes.

*Continued next page...*

## EC50 SELF-CONTAINED AIR-COOLED — LARGE CUBE (Continued)

### 24 Hour Ice Production

Air Temp. Entering Condenser °C	Water Temperature °C						
	10	15	20	25	30	35	40
10	63						
15	59	57					
20	55	53	51	50	48		
25	51	49	48	46	44		
30	47	45	44	42	40	38	36
35			40	38	36	34	32
40					32	30	28
45					28	26	24

Based on average ice weight of 1.24 - 1.32 kg per cycle. Individual cube weight 32 grams ±1.  
Number of individual cubes per cycle: 40

*Continued next page...*

## EC50 SELF-CONTAINED AIR-COOLED — LARGE CUBE (Continued)

### Operating Pressures

Air Temp. Entering Condenser °C	Freeze Cycle		Harvest Cycle	
	Discharge Pressure	Suction Pressure	Discharge Pressure	Suction Pressure
10	9.31-4.48	2.76-.14	2.76-4.83	1.38-2.76
20	14.48-6.21	3.31-.14	4.14-7.58	1.72-4.48
25	14.48-7.58	3.45-.14	4.82-8.27	2.07-4.82
32	17.23-8.96	3.79-.14	6.21-9.65	2.76-5.87
43	24.13-12.07	4.27-.21	7.93-12.76	3.45-7.93

All pressures are in bar. Suction pressure drops gradually throughout the freeze cycle.

## EC50 SELF-CONTAINED WATER-COOLED — STANDARD CUBE

**NOTE:** These characteristics may vary depending on operating conditions.

### Cycle Times

Freeze Time + Harvest Time = Total Cycle Time

Air Temp. Around Ice Machine °C	Freeze Time							Harvest Time
	Water Temperature °C							
	10	15	20	25	30	35	40	
10	19.5-22.1							3.5 min.
15	20.1-22.7	20.6-23.3						
20	20.6-23.3	21.2-23.9	21.8-24.6	22.4-25.3	23.8-26.8			
25	21.2-23.9	22.4-25.3	22.4-25.3	23.1-26.0	23.8-26.8			
30	21.8-24.6	22.4-25.3	23.1-26.0	23.8-26.8	24.5-27.6	25.3-28.5	26.1-29.4	
35			23.8-26.8	24.5-27.6	25.3-28.5	26.1-29.4	27.0-30.4	
40					26.1-29.4	27.0-30.4	27.9-31.4	
45					27.9-31.4	28.9-32.5	29.9-33.7	

Times in minutes.

*Continued next page...*

## EC50 SELF-CONTAINED WATER-COOLED — STANDARD CUBE (Continued)

### 24 Hour Ice Production

Air Temp. Around Ice Machine °C	Water Temperature °C						
	10	15	20	25	30	35	40
10	45						
15	44	43					
20	43	42	41	40	38		
25	42	40	40	39	38		
30	41	40	39	38	37	36	35
35			38	37	36	35	34
40					35	34	33
45					33	32	31

Based on average ice weight of 0.72 - 0.80 kg per cycle. Individual cube weight 19 grams  $\pm$ 1.  
Number of individual cubes per cycle: 40

*Continued next page...*

## EC50 SELF-CONTAINED WATER-COOLED — STANDARD CUBE (Continued)

Condenser Water Consumption	32 Air Temperature Around Ice Machine		
	Water Temperature °C		
	15	21	32
Gal/24 Hours	690	1194	4752

Water regulating valve set to maintain 9 bar discharge pressure.

## Operating Pressures

Water Temperature Entering Condenser °C	Freeze Cycle		Harvest Cycle	
	Discharge Pressure	Suction Pressure	Discharge Pressure	Suction Pressure
10	9.65-7.93	2.34-.07	4.83-7.58	2.41-3.79
20	11.38-7.93	2.48-.07	5.17-9.65	2.41-5.86
25	11.38-7.93	2.62-.07	5.17-9.65	2.41-5.86
32	12.07-8.27	2.90-.07	5.17-9.65	2.41-5.86
43	13.10-8.62	3.59-.07	5.17-9.65	2.41-6.55

Set water regulating valve to 9 bar 5 minutes into freeze cycle. All pressures are in bar. Suction pressure drops gradually throughout the freeze cycle.



## EC50 SELF-CONTAINED WATER-COOLED — LARGE CUBE

**NOTE:** These characteristics may vary depending on operating conditions.

### Cycle Times

Freeze Time + Harvest Time = Total Cycle Time

Air Temp. Around Ice Machine °C	Freeze Time							Harvest Time
	Water Temperature °C							
	10	15	20	25	30	35	40	
10	26.8-28.7							3.5 min.
15	27.3-29.3	28.4-30.4						
20	27.8-29.8	29.0-31.1	30.2-32.4	31.5-33.8	32.2-34.5			
25	29.0-31.1	30.2-32.4	30.8-33.1	32.2-34.5	32.9-35.3			
30	29.6-31.7	30.8-33.1	31.5-33.8	32.9-35.3	34.5-36.9	35.3-37.8	37.1-39.7	
35			32.9-35.3	33.7-36.1	35.3-37.8	37.1-39.7	38.0-40.7	
40					36.2-38.7	38.0-40.7	39.0-41.8	
45					37.1-39.7	39.0-41.8	41.1-44.0	

Times in minutes.

*Continued next page...*

## EC50 SELF-CONTAINED WATER-COOLED — LARGE CUBE (Continued)

### 24 Hour Ice Production

Air Temp. Around Ice Machine °C	Water Temperature °C						
	10	15	20	25	30	35	40
10	59						
15	58	56					
20	57	55	53	51	50		
25	55	53	52	50	49		
30	54	52	51	49	47	46	44
35			49	48	46	44	43
40					45	43	42
45					44	42	40

Based on average ice weight of 1.24 - 1.32 kg per cycle. Individual cube weight 32 grams  $\pm$ 1.  
Number of individual cubes per cycle: 40

*Continued next page...*

## EC50 SELF-CONTAINED WATER-COOLED — LARGE CUBE (Continued)

Condenser Water Consumption	32 Air Temperature Around Ice Machine		
	Water Temperature °C		
	15	21	32
Gal/24 Hours	836	1171	3896

Water regulating valve set to maintain 9 bar discharge pressure.

## Operating Pressures

Water Temperature Entering Condenser °C	Freeze Cycle		Harvest Cycle	
	Discharge Pressure	Suction Pressure	Discharge Pressure	Suction Pressure
10	9.65-7.93	2.34-.07	4.83-7.58	2.41-3.79
20	11.38-7.93	2.48-.07	5.17-9.65	2.41-5.86
25	11.38-7.93	2.62-.07	5.17-9.65	2.41-5.86
32	12.07-8.27	2.90-.07	5.17-9.65	2.41-5.86
43	13.10-8.62	3.59-.07	5.17-9.65	2.41-6.55

Set water regulating valve to 9 bar 5 minutes into freeze cycle. All pressures are in bar. Suction pressure drops gradually throughout the freeze cycle.

## EC65 SELF-CONTAINED AIR-COOLED — STANDARD CUBE

**NOTE:** These characteristics may vary depending on operating conditions.

### Cycle Times

Freeze Time + Harvest Time = Total Cycle Time

Air Temp. Entering Condenser °C	Freeze Time							Harvest Time
	Water Temperature °C							
	10	15	20	25	30	35	40	
10	21.2-23.8							3.0 min.
15	23.4-26.4	25.0-28.1						
20	25.6-28.8	27.4-30.8	29.6-33.2	32.0-35.8	34.8-38.9			
25	27.4-30.8	32.0-35.8	32.0-35.8	34.8-38.9	38.1-42.6			
30	30.3-34.0	32.9-36.8	35.8-40.1	39.3-43.9	43.4-48.5	48.4-54.1	54.7-61.0	
35			39.3-43.9	43.4-48.5	48.4-54.1	54.7-61.0	65.8-73.3	
40					57.1-63.7	65.8-73.3	77.3-86.1	
45					69.2-77.1	82.1-91.4	100.4-111.7	

Times in minutes.

*Continued next page...*

## EC65 SELF-CONTAINED AIR-COOLED — STANDARD CUBE (Continued)

### 24 Hour Ice Production

Air Temp. Entering Condenser °C	Water Temperature °C						
	10	15	20	25	30	35	40
10	59						
15	54	51					
20	50	47	44	41	38		
25	47	41	41	38	35		
30	43	40	37	34	31	28	25
35			34	31	28	25	21
40					24	21	18
45					20	17	14

Based on average ice weight of 1.01 - 1.12 kg per cycle. Individual cube weight 19 grams  $\pm$ 1.  
Number of individual cubes per cycle: 56

*Continued next page...*

## EC65 SELF-CONTAINED AIR-COOLED — STANDARD CUBE (Continued)

### Operating Pressures

Air Temp. Entering Condenser °C	Freeze Cycle		Harvest Cycle	
	Discharge Pressure	Suction Pressure	Discharge Pressure	Suction Pressure
10	12.06-9.65	4.13-1.80	6.21-8.27	4.83-5.87
20	16.20-12.41	4.83-1.93	7.58-10.69	5.52-8.62
25	17.58-14.48	4.83-2.07	7.92-11.72	6.89-9.31
32	20.68-17.24	5.17-2.21	8.27-13.79	7.93-10.34
43	26.20-22.06	5.52-2.48	8.96-14.82	8.96-12.07

All pressures are in bar. Suction pressure drops gradually throughout the freeze cycle.

## EC65 SELF-CONTAINED AIR-COOLED — LARGE CUBE

**NOTE:** These characteristics may vary depending on operating conditions.

### Cycle Times

Freeze Time + Harvest Time = Total Cycle Time

Air Temp. Entering Condenser °C	Freeze Time							Harvest Time
	Water Temperature °C							
	10	15	20	25	30	35	40	
10	28.1-30.0							3.0 min.
15	32.3-34.4	34.1-36.4						
20	35.5-37.9	37.0-39.4	39.4-42.0	41.2-43.9	45.3-48.2			
25	39.4-42.0	46.4-49.4	43.1-46.0	46.4-49.4	48.8-52.0			
30	43.1-46.0	46.4-49.4	48.8-52.0	51.5-54.8	54.5-58.0	59.6-63.4	63.6-67.6	
35			54.5-58.0	59.6-63.4	63.6-67.6	68.0-72.3	76.0-80.8	
40					76.0-80.8	82.3-87.5	89.8-95.4	
45					89.8-95.4	103.8-110.3	115.7-122.9	

Times in minutes.

*Continued next page...*

## EC65 SELF-CONTAINED AIR-COOLED — LARGE CUBE (Continued)

### 24 Hour Ice Production

Air Temp. Entering Condenser °C	Water Temperature °C						
	10	15	20	25	30	35	40
10	68						
15	60	57					
20	55	53	50	48	44		
25	50	43	46	43	41		
30	46	43	41	39	37	34	32
35			37	34	32	30	27
40					27	25	23
45					23	20	18

Based on average ice weight of 1.49 - 1.58 kg per cycle. Individual cube weight 32 grams  $\pm$ 1.  
Number of individual cubes per cycle: 48

*Continued next page...*



## EC65 SELF-CONTAINED AIR-COOLED — LARGE CUBE (Continued)

### Operating Pressures

Air Temp. Entering Condenser °C	Freeze Cycle		Harvest Cycle	
	Discharge Pressure	Suction Pressure	Discharge Pressure	Suction Pressure
10	12.07-9.65	4.14-1.72	6.21-7.58	4.83-6.21
20	15.86-12.41	4.14-1.93	8.27-11.03	5.52-7.93
25	17.58-15.17	4.48-2.07	8.27-11.72	7.58-9.31
32	20.68-17.24	4.83-2.21	8.27-13.79	8.62-10.69
43	25.51-22.06	5.52-2.41	9.31-14.82	9.65-12.07

All pressures are in bar. Suction pressure drops gradually throughout the freeze cycle.

## EC65 SELF-CONTAINED WATER-COOLED — STANDARD CUBE

**NOTE:** These characteristics may vary depending on operating conditions.

### Cycle Times

Freeze Time + Harvest Time = Total Cycle Time

Air Temp. Around Ice Machine °C	Freeze Time							Harvest Time
	Water Temperature °C							
	10	15	20	25	30	35	40	
10	23.9-26.9							3.0 min.
15	23.9-26.9	26.8-30.1						
20	24.5-27.5	26.8-30.1	30.3-34.0	24.8-38.9	39.3-43.9			
25	25.0-28.1	27.4-30.8	31.1-34.9	35.8-40.1	40.6-45.4			
30	25.6-28.8	28.1-31.6	32.0-35.8	36.9-41.3	42.0-46.9	50.4-56.2	62.6-69.8	
35			32.9-42.6	38.1-42.6	43.4-48.5	52.4-58.5	65.8-73.3	
40					45.0-50.3	54.7-61.0	69.2-77.1	
45					46.7-52.1	57.1-63.7	73.0-81.4	

Times in minutes.

*Continued next page...*

## EC65 SELF-CONTAINED WATER-COOLED — STANDARD CUBE (Continued)

### 24 Hour Ice Production

Air Temp. Around Ice Machine °C	Water Temperature °C						
	10	15	20	25	30	35	40
10	53						
15	53	48					
20	52	48	43	38	34		
25	51	47	42	37	33		
30	50	46	41	36	32	27	22
35			40	35	31	26	21
40					30	25	20
45					29	24	19

Based on average ice weight of 1.01 - 1.12 kg per cycle. Individual cube weight 19 grams  $\pm$ 1.  
Number of individual cubes per cycle: 56

*Continued next page...*

## EC65 SELF-CONTAINED WATER-COOLED — STANDARD CUBE (Continued)

Condenser Water Consumption	32 Air Temperature Around Ice Machine		
	Water Temperature °C		
	15	21	32
Gal/24 Hours	689	1057	9488

### Operating Pressures

Water Temperature Entering Condenser °C	Freeze Cycle		Harvest Cycle	
	Discharge Pressure	Suction Pressure	Discharge Pressure	Suction Pressure
10	15.86-15.51	4.55-1.93	6.89-10.00	5.52-6.89
20	15.86-15.51	4.83-1.93	7.58-10.68	6.21-7.93
25	15.86-15.51	4.83-1.93	7.58-10.68	6.21-7.93
32	16.20-15.86	4.83-2.00	7.93-11.03	6.89-8.27
43	17.24-16.20	5.17-2.14	8.27-12.41	7.58-8.96

Set water regulating valve to 15.9 bar 5 minutes into freeze cycle. All pressures are in bar. Suction pressure drops gradually throughout the freeze cycle.

## EC65 SELF-CONTAINED WATER-COOLED — LARGE CUBE

**NOTE:** These characteristics may vary depending on operating conditions.

### Cycle Times

Freeze Time + Harvest Time = Total Cycle Time

Air Temp. Around Ice Machine °C	Freeze Time							Harvest Time
	Water Temperature °C							
	10	15	20	25	30	35	40	
10	32.9-35.1							3.0 min.
15	33.5-35.7	34.8-37.1						
20	34.1-36.4	35.5-37.9	37.0-39.4	38.6-41.1	39.4-42.0			
25	35.5-37.9	37.0-39.4	37.8-40.3	39.4-42.0	40.3-42.9			
30	36.2-38.6	37.8-40.3	38.6-41.1	40.3-42.9	42.2-44.9	43.1-46.0	45.3-48.2	
35			40.3-42.9	41.2-43.9	43.1-46.0	45.3-48.2	46.4-49.4	
40					44.2-47.1	46.4-49.4	47.6-50.7	
45					45.3-48.2	47.6-50.7	50.1-53.4	

Times in minutes.

*Continued next page...*

## EC65 SELF-CONTAINED WATER-COOLED — LARGE CUBE (Continued)

### 24 Hour Ice Production

Air Temp. Around Ice Machine °C	Water Temperature °C						
	10	15	20	25	30	35	40
10	59						
15	58	56					
20	57	55	53	51	50		
25	55	53	52	50	49		
30	54	52	51	49	47	46	44
35			49	48	46	44	43
40					45	43	42
45					44	42	40

Based on average ice weight of 1.49 - 1.58 kg per cycle. Individual cube weight 32 grams  $\pm$ 1.  
Number of individual cubes per cycle: 48

*Continued next page...*

## EC65 SELF-CONTAINED WATER-COOLED — LARGE CUBE (Continued)

Condenser Water Consumption	32 Air Temperature Around Ice Machine		
	Water Temperature °C		
	15	21	32
Gal/24 Hours	836	1171	3896

Water regulating valve set to maintain 15.9 bar discharge pressure.

## Operating Pressures

Water Temperature Entering Condenser °C	Freeze Cycle		Harvest Cycle	
	Discharge Pressure	Suction Pressure	Discharge Pressure	Suction Pressure
10	15.86-15.51	4.14-1.52	6.89-10.00	5.52-6.89
20	15.86-15.51	4.83-1.52	7.58-10.68	6.21-7.93
25	16.20-15.51	4.83-1.52	7.58-10.68	6.21-7.93
32	16.89-15.51	4.83-1.65	7.93-11.03	6.89-8.27
43	17.93-16.20	5.52-1.93	8.27-12.41	7.58-8.96

Set water regulating valve to 15.9 bar 5 minutes into freeze cycle. All pressures are in bar. Suction pressure drops gradually throughout the freeze cycle.

## EC80 SELF-CONTAINED AIR-COOLED — STANDARD CUBE

**NOTE:** These characteristics may vary depending on operating conditions.

### Cycle Times

Freeze Time + Harvest Time = Total Cycle Time

Air Temp. Entering Condenser °C	Freeze Time							Harvest Time
	Water Temperature °C							
	10	15	20	25	30	35	40	
10	15.1-17.2							3.0 min.
15	16.7-18.9	18.0-20.3						
20	18.1-20.5	19.5-22.0	21.1-23.8	22.9-25.8	25.5-28.6			
25	19.7-22.2	22.4-25.2	23.1-26.0	25.3-28.4	27.8-31.3			
30	21.5-24.2	23.4-26.3	25.6-28.8	28.2-31.6	31.2-35.0	35.0-39.2	39.7-44.4	
35			28.5-31.9	31.6-35.5	35.5-39.7	40.3-45.1	46.3-51.7	
40					41.0-45.8	47.2-52.7	55.6-62.1	
45					48.1-53.7	56.8-63.4	69.2-77.1	

Times in minutes.

*Continued next page...*



## EC80 SELF-CONTAINED AIR-COOLED — STANDARD CUBE (Continued)

### 24 Hour Ice Production

Air Temp. Entering Condenser °C	Water Temperature °C						
	10	15	20	25	30	35	40
10	78.1						
15	71.9	67.8					
20	67.3	63.2	59.1	55.1	50.2		
25	62.7	56.2	54.6	50.5	46.4		
30	58.2	54.1	50.0	45.9	41.9	37.8	33.7
35			45.5	41.4	37.3	33.2	29.2
40					32.7	28.7	24.6
45					28.2	24.1	20.0

Based on average ice weight of 1.01 - 1.12 kg per cycle. Individual cube weight 19 grams  $\pm$ 1.  
Number of individual cubes per cycle: 56

*Continued next page...*

## EC80 SELF-CONTAINED AIR-COOLED — STANDARD CUBE (Continued)

### Operating Pressures

Air Temp. Entering Condenser °C	Freeze Cycle		Harvest Cycle	
	Discharge Pressure	Suction Pressure	Discharge Pressure	Suction Pressure
10	13.79-9.65	3.45-1.52	6.89-8.27	4.48-5.17
20	17.24-12.41	4.14-1.93	9.31-11.03	6.21-7.24
25	17.24-13.79	4.48-2.07	10.68-12.41	6.89-7.93
32	21.37-17.24	4.69-2.27	12.07-15.17	8.27-10.00
43	26.20-21.37	5.17-2.48	16.55-17.24	9.65-11.72

All pressures are in bar. Suction pressure drops gradually throughout the freeze cycle.

## EC80 SELF-CONTAINED AIR-COOLED — LARGE CUBE

**NOTE:** These characteristics may vary depending on operating conditions.

### Cycle Times

Freeze Time + Harvest Time = Total Cycle Time

Air Temp. Entering Condenser °C	Freeze Time							Harvest Time
	Water Temperature °C							
	10	15	20	25	30	35	40	
10	19.5-20.9							3.0 min.
15	21.7-23.2	22.5-24.1						
20	23.9-25.5	24.8-26.6	25.9-27.7	27.0-28.9	28.6-30.5			
25	26.4-28.2	28.7-30.6	28.9-30.8	30.2-32.3	31.7-33.9			
30	29.5-31.4	30.9-33.0	32.5-34.7	34.2-36.5	36.1-38.5	38.2-40.7	40.5-43.1	
35			37.0-39.4	39.2-41.8	41.7-44.4	44.4-47.3	47.5-50.5	
40					49.1-52.3	52.8-56.2	57.1-60.8	
45					59.2-63.0	64.8-69.0	71.3-75.8	

Times in minutes.

*Continued next page...*

## EC80 SELF-CONTAINED AIR-COOLED — LARGE CUBE (Continued)

### 24 Hour Ice Production

Air Temp. Entering Condenser °C	Water Temperature °C						
	10	15	20	25	30	35	40
10	93.3						
15	85.1	82.4					
20	78.4	75.7	73.0	70.3	66.9		
25	71.8	66.7	66.3	63.6	60.9		
30	65.1	62.4	59.6	56.9	54.2	51.5	48.8
35			53.0	50.2	47.5	44.8	42.1
40					40.8	38.1	35.4
45					34.2	31.4	28.7

Based on average ice weight of 1.49 - 1.58 kg per cycle. Individual cube weight 32 grams  $\pm$ 1.  
Number of individual cubes per cycle: 48

*Continued next page...*

## EC80 SELF-CONTAINED AIR-COOLED — LARGE CUBE (Continued)

### Operating Pressures

Air Temp. Entering Condenser °C	Freeze Cycle		Harvest Cycle	
	Discharge Pressure	Suction Pressure	Discharge Pressure	Suction Pressure
10	13.79-9.65	3.45-1.59	6.89-8.27	4.48-5.17
20	13.79-17.24	4.48-1.72	9.65-11.38	5.86-6.89
25	18.62-14.48	4.48-1.79	11.03-12.41	6.89-8.27
32	21.37-17.24	4.69-2.07	12.41-15.17	7.58-10.00
43	26.20-22.75	5.17-2.48	13.79-17.24	9.30-12.07

All pressures are in bar. Suction pressure drops gradually throughout the freeze cycle.

## EC80 SELF-CONTAINED WATER-COOLED — STANDARD CUBE

**NOTE:** These characteristics may vary depending on operating conditions.

### Cycle Times

Freeze Time + Harvest Time = Total Cycle Time

Air Temp. Around Ice Machine °C	Freeze Time							Harvest Time
	Water Temperature °C							
	10	15	20	25	30	35	40	
10	16.2-18.3							3.0 min.
15	16.4-18.6	18.2-20.6						
20	16.7-18.9	18.2-20.6	20.0-22.5	22.0-24.8	25.0-28.1			
25	17.0-19.2	18.9-21.3	20.3-22.9	22.5-25.3	25.0-28.1			
30	17.0-19.2	18.5-20.9	20.3-22.9	22.5-25.3	25.0-28.1	28.1-31.6	32.0-35.8	
35			20.7-23.4	22.9-25.8	25.6-28.8	28.8-32.3	32.9-36.8	
40					25.6-28.8	29.6-33.2	33.8-37.9	
45					26.2-29.4	29.6-33.2	33.8-37.9	

Times in minutes.

*Continued next page...*

## EC80 SELF-CONTAINED WATER-COOLED — STANDARD CUBE (Continued)

### 24 Hour Ice Production

Air Temp. Around Ice Machine °C	Water Temperature °C						
	10	15	20	25	30	35	40
10	74						
15	73	67					
20	72	67	62	57	51		
25	71	65	61	56	51		
30	71	66	61	56	51	46	41
35			60	55	50	45	40
40					50	44	39
45					49	44	39

Based on average ice weight of 1.01 - 1.12 kg per cycle. Individual cube weight 19 grams  $\pm$ 1.  
Number of individual cubes per cycle: 56

*Continued next page...*

## EC80 SELF-CONTAINED WATER-COOLED — STANDARD CUBE (Continued)

Condenser Water Consumption	32 Air Temperature Around Ice Machine		
	Water Temperature °C		
	15	21	32
Gal/24 Hours	781	1480	8893

Water regulating valve set to maintain 15.9 bar discharge pressure.

### Operating Pressures

Water Temperature Entering Condenser °C	Freeze Cycle		Harvest Cycle	
	Discharge Pressure	Suction Pressure	Discharge Pressure	Suction Pressure
10	15.86-15.51	4.14-2.00	8.27-10.68	5.52-6.89
20	15.86-15.51	4.14-2.00	8.96-12.41	6.21-8.27
25	15.86-15.51	4.14-2.00	8.96-12.41	6.21-8.27
32	15.86-15.51	4.48-2.07	8.96-12.41	6.55-8.27
43	17.24-16.20	4.48-2.07	8.96-12.41	6.89-8.96

Set water regulating valve to 9 bar 5 minutes into freeze cycle. All pressures are in bar. Suction pressure drops gradually throughout the freeze cycle.



## EC80 SELF-CONTAINED WATER-COOLED — LARGE CUBE

**NOTE:** These characteristics may vary depending on operating conditions.

### Cycle Times

Freeze Time + Harvest Time = Total Cycle Time

Air Temp. Around Ice Machine °C	Freeze Time							Harvest Time
	Water Temperature °C							
	10	15	20	25	30	35	40	
10	14.5-16.4							3.0 min.
15	15.1-17.2	15.9-18.0						
20	15.4-17.4	16.4-18.6	17.3-19.5	18.5-20.9	20.3-22.9			
25	15.6-17.7	17.6-19.9	17.9-20.2	18.9-21.3	20.3-22.9			
30	15.9-18.0	17.0-19.2	18.2-20.6	19.6-22.1	20.7-23.4	22.5-25.3	24.5-27.5	
35			18.5-20.9	20.0-22.5	21.6-24.3	22.9-25.8	25.0-28.1	
40					22.0-24.8	23.9-26.9	25.6-28.8	
45					24.5-27.5	24.5-27.5	26.8-30.1	

Times in minutes.

*Continued next page...*

## EC80 SELF-CONTAINED WATER-COOLED — LARGE CUBE (Continued)

### 24 Hour Ice Production

Air Temp. Around Ice Machine °C	Water Temperature °C						
	10	15	20	25	30	35	40
10	81						
15	78	75					
20	77	73	70	66	61		
25	76	69	68	65	61		
30	75	71	67	63	60	56	52
35			66	62	58	55	51
40					57	53	50
45					56	52	48

Based on average ice weight of 1.49 - 1.58 kg per cycle. Individual cube weight 32 grams  $\pm$ 1.  
Number of individual cubes per cycle: 48

*Continued next page...*

## EC80 SELF-CONTAINED WATER-COOLED — LARGE CUBE (Continued)

Condenser Water Consumption	32 Air Temperature Around Ice Machine		
	Water Temperature °C		
	15	21	32
Gal/24 Hours	826	1316	9060

Water regulating valve set to maintain 15.9 bar discharge pressure.

## Operating Pressures

Water Temperature Entering Condenser °C	Freeze Cycle		Harvest Cycle	
	Discharge Pressure	Suction Pressure	Discharge Pressure	Suction Pressure
10	15.86-15.51	3.79-1.79	8.27-9.65	5.52-6.21
20	15.86-15.51	4.48-1.79	8.96-11.38	6.21-8.27
25	15.86-15.51	4.48-1.79	8.96-11.38	6.21-8.27
32	15.86-15.51	4.48-1.79	8.96-11.38	6.55-8.62
43	17.24-16.20	4.83-1.93	9.65-12.07	7.24-9.65

Set water regulating valve to 15.9 bar 5 minutes into freeze cycle. All pressures are in bar. Suction pressure drops gradually throughout the freeze cycle.

## POWER CONSUMPTION - KWH PER 24 HOURS

Model	Air Temp/Water Temp		
	25/15	32/21	43/32
ECM18A	5.5	6.1	6.9
ECS18A	6.4	6.5	6.8
ECM20A	6.3	6.8	7.0
ECS20A	7.1	7.4	7.8
ECG20A	9.2	9.8	10.5
ECS20W	6.2	6.3	6.4
ECG20W	6.0	6.0	6.2
ECS30A	10.0	10.4	11.1
ECG30A	7.1	7.4	7.8
ECS30W	8.9	8.9	9.2
ECG30W	8.9	8.9	8.9
ECS40A	11.1	11.6	12.3
ECG40A	11.0	11.5	12.2
ECS40W	9.5	9.4	9.2
ECG40W	9.2	9.4	9.2

## POWER CONSUMPTION - KWH PER 24 HOURS

Model	Air Temp/Water Temp		
	25/15	32/21	43/32
ECS50A	12.9	13.3	14.4
ECG50A	12.6	13.0	14.0
ECS50W	11.1	11.2	11.5
ECG50W	11.0	10.9	11.4
ECS65A	12.6	13.1	14.1
ECG65A	12.9	13.2	14.1
ECS65W	11.2	11.3	11.7
ECG65W	11.0	10.9	11.4
ECS80A	15.4	16.3	17.4
ECG80A	15.1	15.8	16.9
ECS80W	13.6	13.8	13.9
ECG80W	13.2	13.4	13.7

## ICE MACHINE HEAT OF REJECTION

Series Ice Machine	Heat of Rejection	
	Air Conditioning	Peak
EC18	1,150	2,300
EC20	1,400	2,600
EC30	1,900	3,300
EC40	2,100	4,100
EC50	2,600	5,000
EC65	2,900	5,000
EC80	4,300	7,400

BTU/Hour

Because the heat of rejection varies during the ice making cycle, the figure shown is an average.

# Refrigerant

## RECOVER/EVACUATION/CHARGING

### Normal Procedures

Do not purge refrigerant to the atmosphere. Capture refrigerant using recovery equipment. Follow the manufacturer's recommendations.

### Important

Manitowoc Ice, Inc. assumes no responsibility for the use of contaminated refrigerant. Damage resulting from the use of contaminated refrigerant is the sole responsibility of the servicing company.

### Important

Replace the liquid line drier before evacuating and recharging. Use only a Manitowoc (O.E.M.) liquid line filter drier to prevent voiding the warranty.

### Connections

1. Suction side of the compressor through the suction service valve.
2. Discharge side of the compressor through the discharge service valve.

## **Self-Contained Recovery/Evacuation**

Place the toggle switch in the OFF position.

Install manifold gauges (with low loss fittings), scale, and recovery unit or two-stage vacuum pump.

Open (backseat) the high and low side on manifold gauges.

Perform recovery or evacuation:

- A. Recovery: Operate the recovery unit as directed by the manufacturer's instructions.
- B. Evacuation prior to recharging: Pull the system down to 500 microns. Then, allow the pump to run for an additional half hour. Turn off the pump and perform a standing vacuum leak check.

**NOTE:** Check for leaks using a halide or electronic leak detector after charging the ice machine.

Follow the Charging Procedures on the next page.



## Charging Procedures

### Important

The charge is critical on all Manitowoc ice machines. Use a scale to ensure the proper charge is installed.

1. Be sure the toggle switch is in the OFF position.
2. Close the vacuum pump valve and the low side manifold gauge valve.
3. Open the high side manifold gauge valve.
4. Open the refrigerant cylinder and add the proper refrigerant charge (shown on nameplate) through the discharge service valve.
5. Let the system “settle” for 2 to 3 minutes.
6. Place the toggle switch in the ICE position.
7. Close the high side on the manifold gauge set. Add any remaining vapor charge through the suction service valve (if necessary).

**NOTE:** Manifold gauges must be removed properly to ensure that no refrigerant contamination or loss occurs.

8. Make sure all vapor in the charging hoses is drawn into the ice machine before disconnecting.
  - a. Run the ice machine in freeze cycle.
  - b. Disconnect the high side service valve at the ice machine.
  - c. Open the high and low side valves on the manifold gauge set. Any refrigerant in the lines will be pulled into the low side of the system.
  - d. Allow the pressures to equalize while the ice machine is in the freeze cycle.
  - e. Disconnect the low side service valve at the ice machine.
9. Install the caps on the refrigeration access valves.

## SYSTEM CONTAMINATION CLEANUP

### General

This section describes the basic requirements for restoring contaminated systems to reliable service.

### Important

Manitowoc Ice, Inc. assumes no responsibility for the use of contaminated refrigerant. Damage resulting from the use of contaminated refrigerant is the sole responsibility of the servicing company.

### DETERMINING SEVERITY OF CONTAMINATION

System contamination is generally caused by either moisture or residue from compressor burnout entering the refrigeration system.

Inspection of the refrigerant usually provides the first indication of system contamination. Obvious moisture or an acrid odor in the refrigerant indicates contamination.

If either condition is found, or if contamination is suspected, use a Total Test Kit from Totaline or a similar diagnostic tool. These devices sample refrigerant, eliminating the need to take an oil sample. Follow the manufacturer's directions.

If a refrigerant test kit indicates harmful levels of contamination, or if a test kit is not available, inspect the compressor oil.

1. Remove the refrigerant charge from the ice machine.
2. Remove the compressor from the system.
3. Check the odor and appearance of the oil.
4. Inspect open suction and discharge lines at the compressor for burnout deposits.
5. If no signs of contamination are present, perform an acid oil test to determine the type of cleanup required.

## Contamination/Cleanup Chart

<b>Symptoms/Findings</b>	<b>Required Cleanup Procedure</b>
No symptoms or suspicion of contamination.	Normal evacuation/recharging procedure
Moisture/Air Contamination symptoms. Refrigeration system open to atmosphere for longer than 15 minutes. Refrigeration test kit and/or acid oil test shows contamination. No burnout deposits in open compressor lines.	Mild contamination cleanup procedure
Mild Compressor Burnout symptoms. Oil appears clean but smells acrid. Refrigeration test kit or acid oil test shows harmful acid content. No burnout deposits in open compressor lines.	Mild contamination cleanup procedure
Severe Compressor Burnout symptoms. Oil is discolored, acidic, and smells acrid. Burnout deposits found in the compressor, lines, and other components.	Severe contamination cleanup procedure

## MILD SYSTEM CONTAMINATION CLEANUP

### Procedure

1. Replace any failed components.
2. If the compressor is good, change the oil.
3. Replace the liquid line drier.

**NOTE:** If the contamination is from moisture, use heat lamps during evacuation. Position them at the compressor, condenser and evaporator prior to evacuation. Do not position heat lamps too close to plastic components, or they may melt or warp.

### Important

Dry nitrogen is recommended for this procedure. This will prevent CFC release.

Follow the normal evacuation procedure, except replace the evacuation step with the following:

- A. Pull vacuum to 1000 microns. Break the vacuum with dry nitrogen and sweep the system. Pressurize to a minimum of .35 bar.
- B. Pull vacuum to 500 microns. Break the vacuum with dry nitrogen and sweep the system. Pressurize to a minimum of .35 bar.
- C. Change the vacuum pump oil.
- D. Pull vacuum to 500 microns. Run the vacuum pump for 1/2 hour on self-contained models, 1 hour on remotes.

**NOTE:** Perform a pressure test to be sure there are no leaks.

Charge the system with the proper refrigerant to the nameplate charge.

Operate the ice machine.

## **SEVERE SYSTEM CONTAMINATION CLEANUP PROCEDURE**

1. Remove the refrigerant charge.
2. Remove the compressor.
3. Wipe away any burnout deposits from suction and discharge lines at compressor.
4. Sweep through the open system with dry nitrogen.

### **Important**

Refrigerant sweeps are not recommended, as they release CFC's into the atmosphere.

5. Install a new compressor and new start components.
6. Install suction line filter-drier in front of compressor.
7. Install a new liquid line drier.

## **Important**

Dry nitrogen is recommended for this procedure.  
This will prevent CFC release.

- A. Pull vacuum to 1000 microns. Break the vacuum with dry nitrogen and sweep the system. Pressurize to a minimum of .35 bar.
- B. Change the vacuum pump oil.
- C. Pull vacuum to 500 microns. Break the vacuum with dry nitrogen and sweep the system. Pressurize to a minimum of .35 bar.
- D. Change the vacuum pump oil.
- E. Pull vacuum to 500 microns. Run the vacuum pump for 1 hour additional hour.

Charge the system with the proper refrigerant to the nameplate charge.

Operate the ice machine for one hour. Then, check the pressure drop across the suction line filter-drier.

- F. If the pressure drop is less than .14 bar, the filter-drier should be adequate for complete cleanup.
- G. If the pressure drop exceeds .14 bar, change the suction line filter-drier and the liquid line drier. Repeat until the pressure drop is acceptable.

Operate the ice machine for 48-72 hours. Replace the suction line and liquid line drier if necessary.

## **FILTER-DRIERS**

### **Liquid Line Filter Drier**

The filter-drier used on Manitowoc ice machines are manufactured to Manitowoc specifications.

The difference between a Manitowoc drier and an off-the-shelf drier is in filtration. A Manitowoc drier has dirt-retaining filtration, with fiberglass filters on both the inlet and outlet ends. This is very important because ice machines have a back-flushing action that takes place during every harvest cycle.

A Manitowoc filter-drier has a very high moisture removal capability and a good acid removal capacity.

### **Important**

The liquid line drier is covered as a warranty part. The liquid line drier must be replaced any time the system is opened for repair.







**MANITOWOC ICE, INC.**  
**2110 South 26th Street P.O. Box 1720**  
**Manitowoc, WI 54221-1720 USA**  
**Phone: 920-682-0161 Fax: 920-683-7585**  
**Website – [www.manitowocice.com](http://www.manitowocice.com)**

**©2007 Manitowoc Ice, Inc.**