

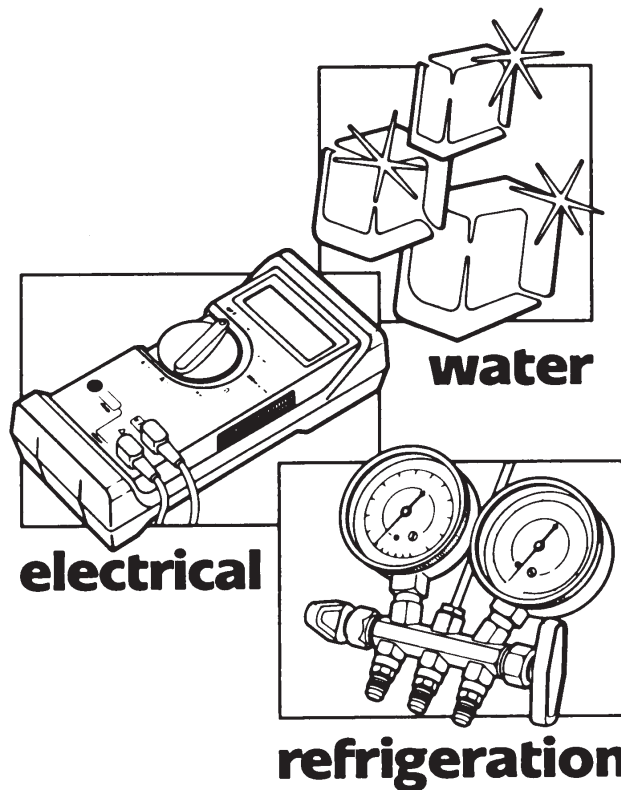

Manitowoc[®]
SERVICE
TECHNICIAN'S
HANDBOOK

B MODEL
ICE MACHINES



©Manitowoc 1993, Rev A 1/99
P/N 83-5367-9

TABLE OF CONTENTS

| | Page |
|-----------------------------------------------------------------------------|------|
| Ice Machine Warranty | 1 |
| Installation | |
| Wiring Connections | |
| Self-Contained | 3 |
| Remotes | 4 |
| Remote Condenser/Line Set Installation | |
| General | 6 |
| Routing of Line Set | 6 |
| Condenser Maximum Location Distance | 8 |
| Lengthening or Reducing Line Set Lengths | 11 |
| Connection of Line Set | 11 |
| Ice Machine Heat Rejection | 12 |
| Cooling Tower Applications (Water-Cooled Models) | 12 |
| Operational Checks | |
| Water Level | 13 |
| Ice Thickness | 14 |
| Interior Cleaning and Sanitizing | |
| Self-Cleaning System (SeCS™) | |
| Cleaning Procedures | 15 |
| Sanitizing Procedures | 17 |
| Automatic Cleaning System (AuCS™) Accessory | |
| Automatic Operation | 18 |
| Manual Start Operation | 18 |
| Sequence of Operation | 19 |
| Removal of Parts for Cleaning/Sanitizing | 21 |
| Water Treatment/Filtration (Tri-Liminator™) | 27 |
| Ice Machine Removal From Service/Winterization | 29 |
| Ice Machine Sequence of Operation | |
| Self-Contained Air or Water-Cooled | |
| B150/B200/B250/B320/B420 | |
| B450/B600/B800/B1000 | 31 |
| B1300/B1800 | 33 |
| Remote | |
| B450/B600/B800/B1000 | 35 |
| B1300/B1800 | 37 |
| Electrical System | |
| Component Specifications and Diagnostics | |
| Bin Switch | 39 |

(Continued on next page)

Table of Contents (continued)

| | |
|--------------------------------------------------------------------------|----|
| Compressor (Electrical Diagnostics Only) | 41 |
| Discharge Line Thermistor | 46 |
| Ice/Off/Self-Clean Toggle Switch | 49 |
| Control Board (Unitized Ice Sensor Board) | |
| Single Evaporator Pictorial Diagram | 50 |
| Dual Evaporator Pictorial Diagram | 51 |
| General | 52 |
| Harvest Initiation (Ice Thickness Probe) | 52 |
| Bin Switch Light | 52 |
| Harvest/Safety Limit Light | 52 |
| Freeze Time Lock-In Feature | 53 |
| Water Curtain Removal | 53 |
| 7 amp Fuse | 54 |
| Diagnosing Electrical Control Circuitry | |
| Ice Machine Will Not Run | 55 |
| Ice Machine Operates But Will Not Cycle Into Harvest | 56 |
| Ice Machine Operates But Harvests Prematurely | 58 |
| Wiring Diagrams | |
| Self-Contained Air or Water-Cooled | |
| Single Evaporator - 1 Phase | 59 |
| 3 Phase | 60 |
| Dual Evaporator - 1 Phase | 61 |
| 3 Phase | 62 |
| Remote | |
| Single Evaporator - 1 Phase | 63 |
| 3 Phase | 64 |
| Dual Evaporator - 1 Phase | 65 |
| 3 Phase | 66 |
| 380/415V/50Hz - 3 Phase | 67 |
| Refrigeration System | |
| Harvest Pressure Regulation (H.P.R.) System | |
| General | 78 |
| H.P.R. System Failure Chart | 80 |
| Filter-Driers | 82 |
| Headmaster Control Valve | 83 |
| Headmaster Control Valve Failure Chart | 85 |
| Fan Cycle Control | 86 |
| Low Pressure Cut-Out Control | 87 |
| High Pressure Cut-Out Control | 88 |
| Refrigeration System Operational Analysis | |
| General | 89 |
| Before Beginning Service (Questions To Ask End User) | 91 |

(Continued on next page)

Table of Contents (continued)

| | |
|----------------------------------------------------------------------------------------|-----|
| Installation/Visual Inspection Checklist | 92 |
| Water System Checklist | 93 |
| Ice Production Check | 94 |
| Ice Formation on Evaporator | 96 |
| Safety Limits | |
| General | 98 |
| Determine Which Safety Limit Stopped | |
| Ice Machine | 98 |
| Analyzing Why Safety Limit Stopped | |
| Ice Machine | 100 |
| Hot Gas Valve Temperature Check | 105 |
| Evaporator Inlet To Outlet Temperature | |
| Comparison (Single Evaporator) | 107 |
| Left to Right Evaporator Inlet Temperature | |
| Comparison (Dual Evaporator) | 108 |
| Analyzing Discharge Pressure | 109 |
| Analyzing Suction Pressure | 112 |
| How to Use Operational Analysis Tables | 117 |
| Operational Analysis Tables | 119 |
| (Use to diagnose refrigeration problems) | |
| Single Evaporator Table | 120 |
| Dual Evaporator Table | 124 |
| Refrigeration Tubing Schematics | |
| Self-Contained Air or Water-Cooled | |
| B150 | 128 |
| B200/B250/B320/B420/B450/B600 | |
| B800/B1000 | 129 |
| B1300/B1800 | 130 |
| Remotes | |
| B450/B600/B800/B1000 | 131 |
| B1300/B1800 | 132 |
| Cycle Times/24 Hour Ice Production/ Operating Refrigeration Pressure Charts | |
| B150 | 133 |
| B200 | 135 |
| B250 | 137 |
| B320 | 139 |
| B420/B450 | 141 |
| B600 | 144 |
| B800 | 147 |
| B1000 | 150 |
| B1300 | 153 |
| B1800 | 156 |

(Continued on next page)

Table of Contents (continued)

Refrigerant Recovery/Evacuation and Recharging

Self-Contained B-Model Ice Machines

Recovery/Evacuation Procedures 161

Charging Procedures 163

Remote B-Model Ice Machines

Recovery/Evacuation Procedures 165

Charging Procedures 167

Refrigerant Charge 169

Charging With SUVA® HP81
(using charging cylinders) 170

Replacing Pressure Controls Without Removing

Refrigerant Charge 171

Refrigeration System Contamination 173

Contamination/Clean-up Chart 174

Contamination Clean-up Procedures 175

Recovery/Recycle/Reclaim Definitions 178

Manitowoc Policy on Refrigerant Reuse 179

SUVA® HP81 Questions and Answers 181

(End)

ICE MACHINE WARRANTY INFORMATION

IMPORTANT

Read this section very carefully for warranty explanation.
(Refer to Warranty Bond for complete details.)

OWNER WARRANTY REGISTRATION CARD

Warranty coverage begins the day the ice machine is installed.

IMPORTANT

To validate the installation date, the OWNER WARRANTY REGISTRATION CARD must be mailed in.

If the card was not returned, Manitowoc will use the date of sale to the Manitowoc Distributor as the first day of warranty coverage for your new ice machine.

WARRANTY COVERAGE

(Effective for Ice Machines Installed after January 1, 1991)

Parts

1. The ice machine is warranted against defects in materials and workmanship under normal use and service for three (3) years from the date of the original installation. It is important to send in the warranty registration card so Manitowoc can begin your warranty on the installation date.
2. An additional two (2) years (five (5) years total) warranty is provided on evaporator and compressor from the date of original installation.



WARNING

PERSONAL INJURY POTENTIAL

Do not operate equipment that has been misused, abused, neglected, damaged, or altered/modified from that of original manufactured specifications.

Labor

1. Labor to repair or replace defective components is warranted for three (3) years from the date of original installation.
2. An additional two (2) years (five (5) years total) labor warranty is provided on the evaporator from the date of original installation.

Exclusions from Warranty Coverage

The following items are not included in the warranty coverage of the ice machine.

1. Normal maintenance, adjustments and cleaning as outlined in the Use and Care Guide.
2. Repairs due to unauthorized modifications to the ice machine or the use of nonapproved parts without written approval from Manitowoc Ice, Inc.
3. Damage from improper installation as outlined in the Installation Instructions; improper electrical supply, water supply or drainage; flood; storms; or other acts of God.
4. **Premium labor rates due to holidays, overtime, etc.; travel time; flat rate service call charges; mileage and miscellaneous tools and material charges not listed on the payment schedule are excluded as well as additional labor charges resulting from inaccessibility of the ice machine.**
5. Parts or assemblies subjected to misuse, abuse, neglect or accidents.
6. When the ice machine has been installed, cleaned and/or maintained inconsistent with the technical instructions provided in the Owner/Operator Use and Care Guide and the Installation Manual.

Authorized Warranty Service

To comply with the provisions of the warranty, a refrigeration service company qualified and authorized by a Manitowoc distributor or a Contracted Service Representative must perform the warranty repair.

INSTALLATION: WIRING CONNECTIONS

SELF-CONTAINED ELECTRICAL CONNECTIONS

CAUTION

The accompanying diagrams are not intended to show proper wire routing, wire sizing, disconnects, etc.; only the correct wire connections. **All electrical connections and routing must conform to local and national codes.**

**115/1/60
-OR-
208-230/1/60**

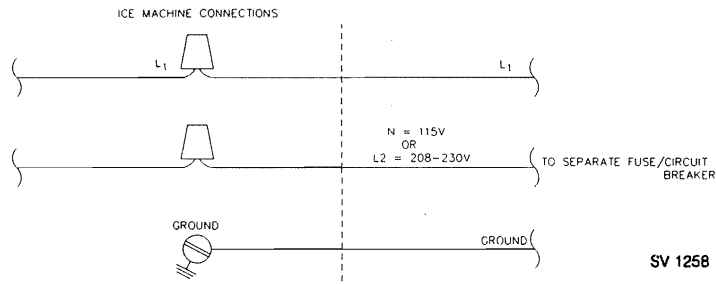

208-230/3/60

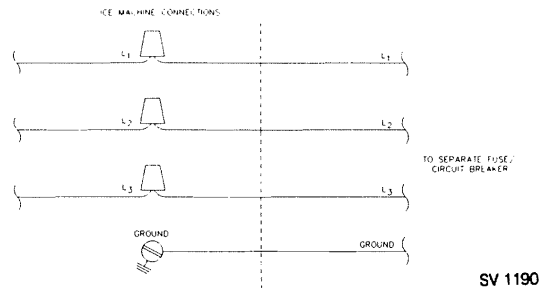

220-240/1/50

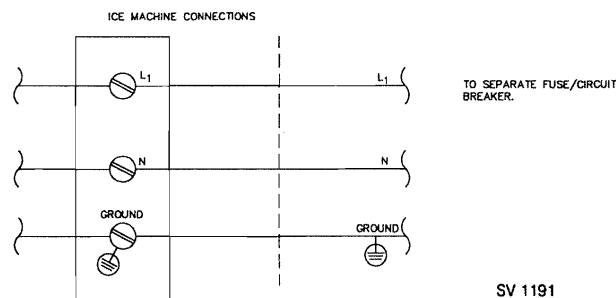

REMOTE ELECTRICAL CONNECTIONS

CAUTION

The diagrams are not intended to show proper wire routing, wire sizing, disconnects, etc.; only the proper wire connections. **All electrical connections and routing must conform to local and national codes.**

The single circuit condenser should be wired directly to the ice machine's electrical panel. The condenser fan runs only when the ice machine is operating.

REMOTE ICE MACHINE 115/1/60 -OR- 208-230/1/60 With model condenser single circuit

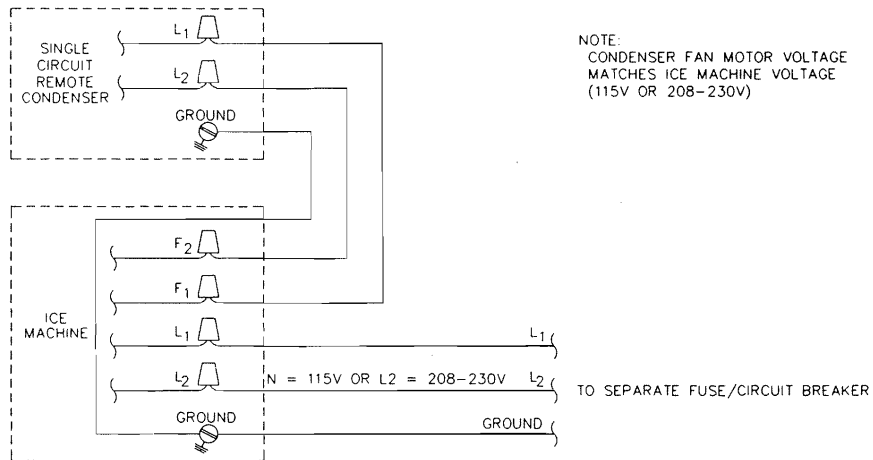

SV1255

**REMOTE ICE MACHINE
208-230/3/60
With single circuit model condenser**

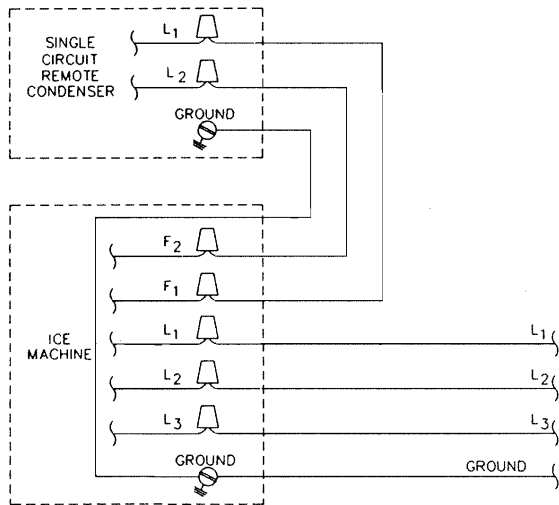

NOTE:
FAN MOTOR IS 208-230 VOLT

TO SEPARATE FUSE/
CIRCUIT BREAKER
(208-230V)

SV1199

**REMOTE ICE MACHINE
220-240/1/50
With single circuit model condenser**

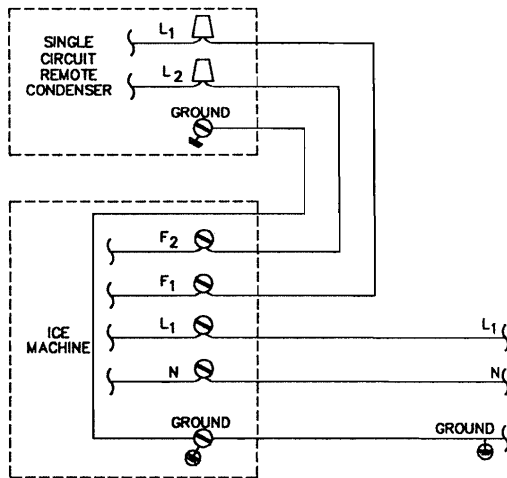

NOTE:
FAN MOTOR IS 220-240 VOLT

TO SEPARATE FUSE/CIRCUIT BREAKER
(220-240).

SV 1256

REMOTE CONDENSER/ LINE SET INSTALLATION

| Ice Machine | Remote Single Circuit Condenser | Line Set Size | |
|-------------|---------------------------------|---------------|--------|
| | | Discharge | Liquid |
| B450 | BC0495 | 1/2" | 5/16" |
| B600 | BC0895 | 1/2" | 5/16" |
| B800 | BC0895 | 1/2" | 5/16" |
| B1000 | BC1095 | 1/2" | 5/16" |
| B1300 | BC1395 | 1/2" | 3/8" |
| B1800 | BC1895 | 1/2" | 3/8" |

| Air temperature entering the condenser | |
|----------------------------------------|----------------|
| Minimum | Maximum |
| -20°F (-28.9°C) | 130°F (54.4°C) |

Condensers must be mounted horizontally with the fan motor on top (Refer to illustrations).

GENERAL

Remote condenser installations consist of vertical and horizontal line set distances between the machine and condenser. When combined, they must fit within approved guidelines. These guidelines, drawings, and calculation methods must be followed to verify a proper remote condenser installation.

Warranty Note

The sixty (60) month compressor warranty, including the thirty-six (36) month labor replacement warranty, will not apply when the remote ice machine is not installed according to specifications, or the refrigeration system is modified with a condenser, heat reclaim device, or parts and assemblies other than those manufactured by Manitowoc Ice, Inc., unless Manitowoc Ice, Inc. approves these modifications for specific locations in writing.

ROUTING OF LINE SET

Follow these guidelines when routing refrigerant lines. This will insure the proper performance and service accessibility to the ice machine. A 2-1/2" round hole in the wall or roof is needed for tubing routing.

NOTE

Line set end with 90° bend connects to ice machine. The straight end connects to the remote condenser.

1. Make the service loop in the line sets as shown. This permits easy access to the ice machine for cleaning and service. Hard rigid copper should not be used at this location.
2. Never form a trap in refrigeration lines. Refrigerant oil must always be free to drain toward the ice maker or the condenser. The trap formed by the service loop is part of the ice machine's design.

Excess tubing must be routed in a downward horizontal spiral and supported to assure it does not collapse. Do not coil tubing vertically.

3. Refrigerant lines located outdoors should be kept as short as possible, and must be run to prevent traps.

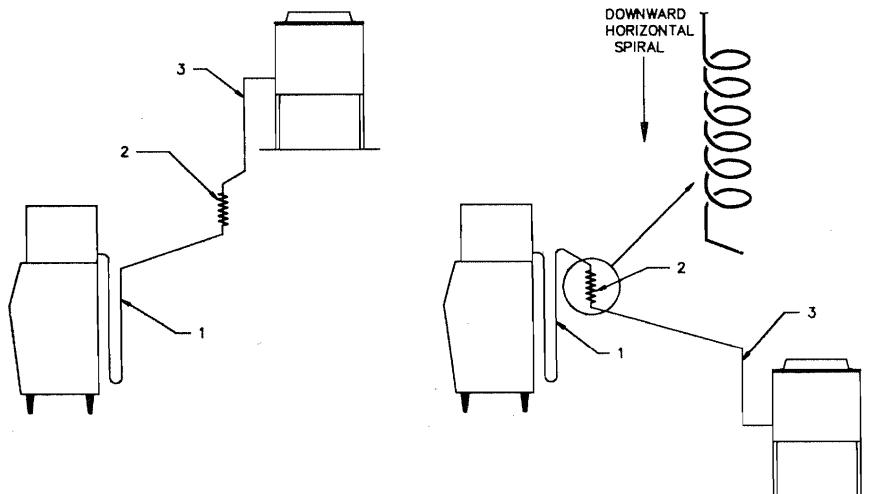

SV1204

REMOTE CONDENSER MAXIMUM LOCATION DISTANCES

Physical Line Set Length: 100 Ft. Maximum

The ice machine compressor must have the proper oil return. The receiver capacity is only designed to hold the nameplate charge. This is sufficient to operate the ice machine in ambient temperatures of -20°F (-28.9°C) to 130°F (54.4°C) with line set lengths up to 100 ft.

LINE SET RISE: 35 FT. MAXIMUM

LINE SET DROP: 15 FT. MAXIMUM

Line set rises, drops, or horizontal runs greater than the maximum distance allowed will exceed the compressor start-up and pumping design limits, and will result in poor oil return to the compressor.

Calculated Line Set Distance: 150 Ft. Maximum

To eliminate the combination of rises, drops, and horizontal runs exceeding the compressor start-up and pumping design limits, the following calculations must be made:

Step 1. Insert measured rise (R) into formula and multiply it by 1.7 to get a calculated rise.

Example: A condenser located 10 ft. above the ice machine has a 17 ft. calculated total (10 ft. x 1.7 = 17 ft.).

Step 2. Insert measured drop (D) into formula and multiply by 6.6 to get a calculated drop.

Example: A condenser located 10 ft. below the ice machine has a 66 ft. calculated total (10 ft. x 6.6 = 66 ft.).

Step 3. Insert measured horizontal distance into formula. No calculation is necessary.

Step 4. Add the calculated rise, calculated drop, and horizontal distance together to get the total calculated distance. If 150 ft. total calculated distance is exceeded, the condenser must be moved to a new location which permits proper equipment operation.

IMPORTANT

If a line set rise is followed by a line set drop, a second line set rise cannot be made.

-OR-

If a line set drop is followed by a line set rise, a second line set drop cannot be made.

MAXIMUM LINE SET DISTANCE FORMULA

Step 1.

Measured Rise _____ x 1.7 = _____ Calculated Rise
(35 ft. Maximum)

Step 2.

Measured Drop _____ x 6.6 = _____ Calculated Drop
(15 ft. Maximum)

Step 3.

Measured Horizontal Distance = _____ Horizontal
(100 ft. Maximum) Distance

Step 4.

Total Calculated Distance = _____ Total Calculated
(150 ft. Maximum) Distance

Combination of
Rise(s) with Horizontal

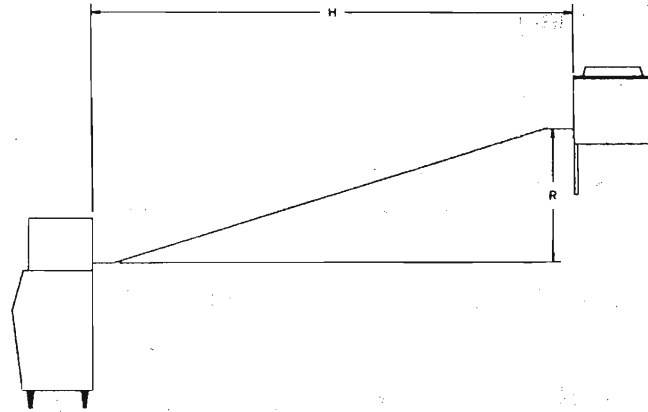

SV 1196

Combination of
Drop(s) with Horizontal

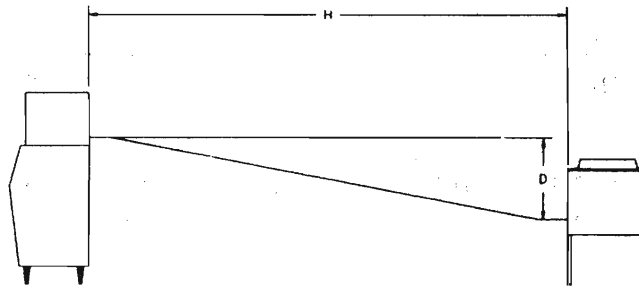

SV 1195

Combination of
Rise and Drop with Horizontal

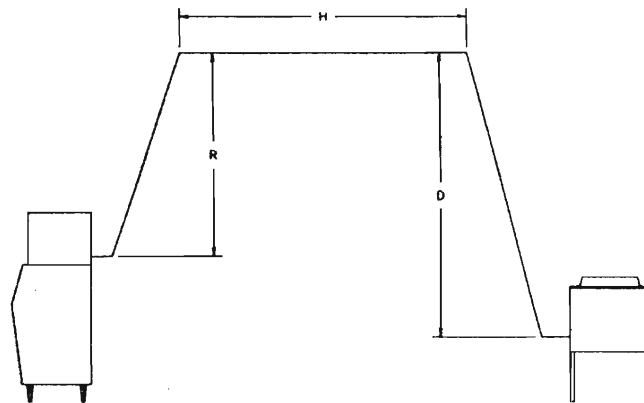

SV 1194

LENGTHENING OR REDUCING LINE SET LENGTHS

In most cases, by routing the line set properly, shortening will not be necessary (refer to illustration). When shortening or lengthening is required, do so before connecting the line set to the ice machine or the remote condenser. This prevents the loss of refrigerant in the ice machine or the condenser.

The quick connect fittings on the line sets are equipped with Schrader valves. Use these valves to recover any vapor charge from the line set. When lengthening or shortening lines, apply good refrigeration practices and insulate new tubing. Do not change the tube sizes. Evacuate the lines and place approximately 5 oz. of vapor refrigerant charge in each line.

CONNECTION OF LINE SET

1. Remove the dust caps from the line set, the condenser, and the ice machine.
2. Apply refrigeration oil to the threads on the quick disconnect couplers before connecting them to the condenser.
3. Carefully thread the female fitting to the condenser or ice machine by hand.
4. Using the proper size wrench, tighten the couplings until they bottom out. Turn an additional 1/4 turn to ensure proper brass-to-brass seating. (If a torque wrench is used, liquid line: 10-12 ft. lbs; discharge line: 35-45 ft. lbs.).
5. Check all fittings for leaks.

CAUTION

If it is necessary to remove the connecting couplers from the ice machine or remote condenser, remove all refrigerant from the ice machine before attempting to remove the quick connect couplers.

ICE MACHINE HEAT REJECTION

Ice machines, like other refrigeration equipment, reject heat through the condenser. It is helpful to know the amount of heat rejected to accurately size air conditioning equipment when self-contained air-cooled ice machines are installed in air conditioned environments. **This heat rejection information is also necessary to evaluate the benefits of using water-cooled or remote condensers to reduce air conditioning loads.** The amount of heat added to an air conditioned environment by an ice machine using a water-cooled or remote condenser is negligible. Knowing the amount of heat rejected is also important when sizing a cooling tower for a water-cooled condenser unit.

| Model Series | Heat Rejected (BTU's/Hr) | |
|--------------|--------------------------|--------|
| | Air Conditioning | Peak |
| B150 | 3,200 | 4,600 |
| B200 | 3,800 | 5,000 |
| B250 | 4,000 | 5,200 |
| B320 | 4,600 | 6,200 |
| B420/B450 | 7,000 | 9,600 |
| B600 | 9,000 | 13,900 |
| B800 | 12,400 | 19,500 |
| B1000 | 16,000 | 24,700 |
| B1300 | 24,000 | 35,500 |
| B1800 | 31,000 | 45,000 |

Water-Cooled Models (Cooling Tower Applications)

A water-cooling tower installation does not require modification to the ice machine; the water regulator valve for the condenser continues to control the refrigeration discharge pressure. It is necessary to know the amount of heat rejection and the pressure drop through the condenser and water valve (inlet and outlet of the ice machine) to apply these types of systems to the ice machine.

- Water entering the condenser must not exceed 90°F (32.2°C).
- Water flow through the condenser must not exceed 5 gallons per minute.
- Allow for a pressure drop of 7 psi between the condenser water inlet and outlet of the ice machine.
- Condenser water exiting temperature must not exceed 110°F (43.3°C).

OPERATIONAL CHECKS

Your Manitowoc ice machine is factory operated and adjusted before shipment. Normally, new installations do not require any adjustment. To ensure proper operation, always follow the Operational Checks when starting the ice machine for the first time, after a prolonged "out of service" period, and after cleaning and sanitizing.

Routine adjustments and maintenance procedures outlined in this guide are not covered by the warranty.

WATER LEVEL CHECK

1. Check the water level while the machine is in the freeze mode and the water pump is running.

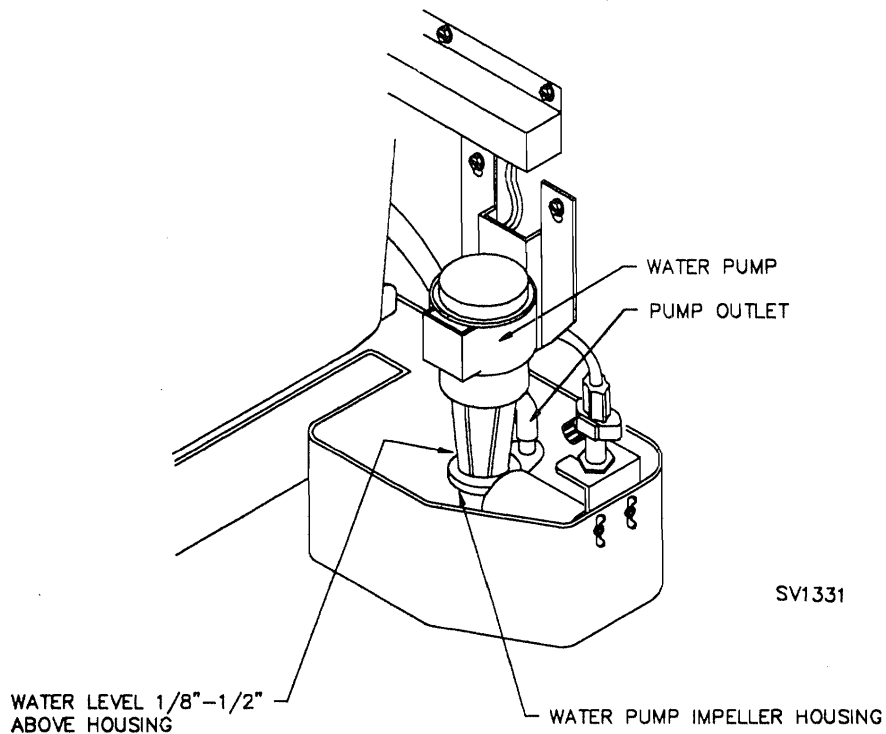

WATER LEVEL CHECK

2. The water level is correct when it is $1/8'' - 1/2''$ above the water pump impeller housing.

Carefully bend the float arm to achieve the correct water level.

ICE THICKNESS CHECK

The ice thickness probe is factory set to maintain the ice bridge thickness at 1/8".

Make sure the water curtain is in place when performing the Ice Thickness Check. The water curtain prevents water from splashing out of the water trough.

Inspect the bridge connecting the cubes. The bridge should be approximately 1/8" thick. Follow the steps below if any adjustment is needed.

1. Turn the ice thickness probe adjustment screw clockwise to increase the bridge thickness or counterclockwise to decrease the bridge thickness.

NOTE

A 1/3 turn of the adjustment screw changes the ice thickness approximately 1/16".

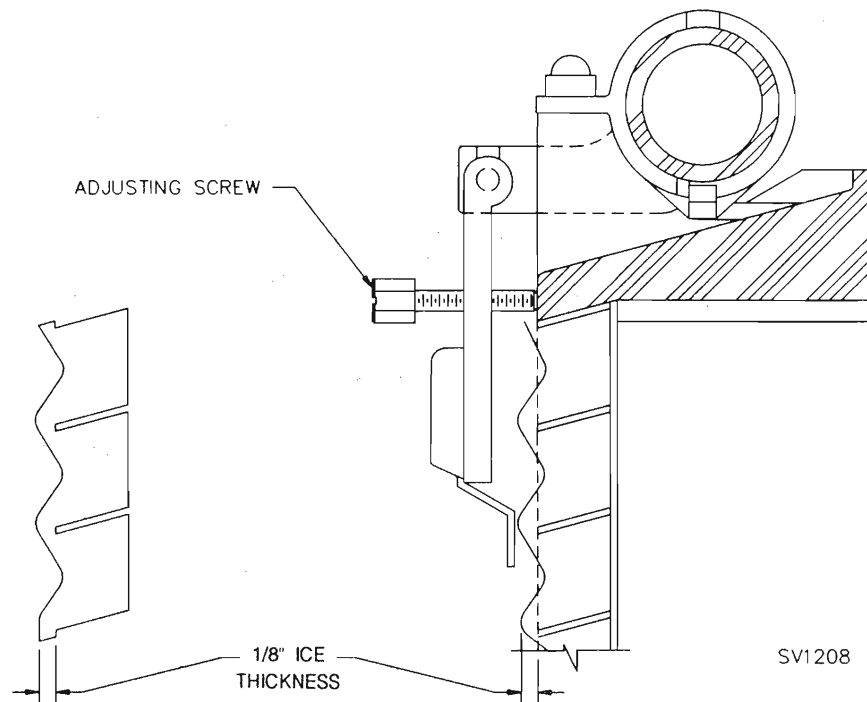

ICE THICKNESS CHECK

2. Make sure that the ice thickness probe wires and bracket do not restrict movement of the probe.

INTERIOR CLEANING AND SANITIZING

SELF-CLEANING SYSTEM (SeCS™)

Clean and sanitize the ice machine every six months for efficient operation. If the ice machine requires more frequent cleaning and sanitizing, consult a qualified service company to test the water quality and recommend appropriate water treatment or installation of AuCS™ accessory (Automatic Cleaning System).

WARNING

Use only Manitowoc approved Ice Machine Cleaner (part number 94-0546-3) and Sanitizer (part number 94-0565-3). It is a violation of Federal law to use these solutions in a manner inconsistent with their labeling. Read and understand all labels printed on bottles before use.

CLEANING PROCEDURES

Ice machine cleaner is used to remove lime scale or other mineral deposits. It is not used to remove algae or slime. Refer to the section on Sanitizing for the removal of algae and slime.

CAUTION

Do not mix Cleaner and Sanitizer solutions together. It is a violation of Federal law to use these products in a manner inconsistent with their labeling.

WARNING

Wear rubber gloves and safety goggles (and/or face shield) when handling ice machine cleaner or sanitizer.

NOTE

If required, extremely dirty ice machines may be taken apart for cleaning and sanitizing.

1. Set the toggle switch to the OFF position after the ice falls from the evaporator at the end of a Harvest cycle. Or, set the switch to the OFF position and allow the ice to melt off of the evaporator.

CAUTION

Never use anything to force ice from the evaporator. Damage may result.

2. To start self-cleaning, place the toggle switch in the CLEAN position. The water will flow through the water dump valve and down the drain.
3. Wait about one minute or until water starts to flow over the evaporator.
4. **Single evaporator ice machines:** add 2 ounces of Manitowoc cleaner to the water trough.
Dual evaporator ice machines: add 4 ounces of Manitowoc cleaner to the water trough.
5. The ice machine Self Cleaning System (SeCS™) will automatically time out a ten minute cleaning cycle, followed by six rinse cycles, and then stop. (This cycle lasts approximately 25 minutes.)
6. When the self-cleaning stops, move the switch to the OFF position and proceed to the sanitizing section.

SANITIZING PROCEDURES

Use Sanitizer to remove algae or slime. Do not use it to remove lime scale or other mineral deposits.

The Self Cleaning System (SeCS™) is also used for sanitizing:

1. Set the toggle switch to the OFF position after the ice falls from the evaporator at end of a Harvest cycle. Or, set the switch to the OFF position and allow the ice to melt off of the evaporator.
2. Place the toggle switch in the CLEAN position. The water will flow through the water dump valve and down the drain.
3. Wait about one minute or until water starts to flow over the evaporator.
4. **Single evaporator ice machine:** add 3 ounces of Manitowoc ice machine sanitizer to water trough.
Dual evaporator ice machine: add 6 ounces of Manitowoc ice machine sanitizer to water trough.
5. The ice machine Self Cleaning System (SeCS™) will automatically time out a ten minute sanitizing cycle, followed by six rinse cycles, and then stop. (This lasts approximately 25 minutes.)

If the bin requires sanitizing, remove all the ice and sanitize it with a solution of one ounce of sanitizer to up to four gallons of water.

Rinse **all** sanitized surfaces with clean water.

6. When the self cleaning (sanitizing) cycle stops, move the toggle switch to the ICE position.

AUTOMATIC CLEANING SYSTEM (AuCS™) ACCESSORY

This accessory monitors ice making cycles and initiates self cleaning procedures automatically. The AuCS™ Accessory can be set to automatically clean or sanitize the ice machine every 2, 4 or 12 weeks.

DANGER

Refer to the AuCS™ Accessory Installation-Owner/Operator Use and Care Guide for complete details on the installation, operation, maintenance and cautionary statements of this accessory.

AUTOMATIC OPERATION

The following occurs when the toggle switch is in the ice making position:

1. The ice machine unitized ice sensor board counts the number of ice harvest cycles.
2. The AuCS™ Accessory automatically interrupts the ice making mode and starts the automatic cleaning mode when the harvest count equals the "frequency of cleaning" setting of the AuCS™ Accessory.
3. When the automatic cleaning mode is complete (approximately 25 minutes), ice making mode resumes automatically.

NOTE

The harvest count is reset to zero only after the AuCS™ cycle is completed. It cannot be reset by unplugging the modular wire, changing the switch position, power loss, etc.

MANUAL START OPERATION

Verify that no ice is on the evaporator surface. (Move the ICE/OFF/CLEAN switch to the OFF position after the ice falls from the evaporator at end of a harvest cycle, or move the switch to the OFF position and allow the ice to melt off of the evaporator.)

The following occurs when the toggle switch is moved to the cleaning position:

1. The ice machine runs through one dump cycle and then into the automatic cleaning mode.
2. The ice machine stops all functions when the automatic cleaning mode is completed. Move the switch to the ice making position to restart.

NOTE

The harvest counter for automatic operation is reset to zero after the automatic cleaning mode cycle is complete.

SEQUENCE OF OPERATION

The ice machine automatically times out a ten minute clean (or sanitize) cycle, followed by six rinse cycles. The automatic cleaning mode lasts approximately 25 minutes.

NOTE

Opening or removing the water curtain stops the automatic cleaning mode. Upon reclosing, the automatic cleaning mode resumes from the point at which it stopped.

1. Clean (or Sanitize) Cycle
(10 minutes, 45 seconds)

- A. The water pump circulates water over the evaporator for 10 minutes. The cleaner or sanitizer is dispensed from the AuCS™ Accessory for 10-20 seconds at the beginning of the cycle.

IMPORTANT

Once the cleaner or sanitizer solution is dispensed during the clean cycle, you cannot stop the ice machine from running through all six rinse cycles before starting another ice making mode.

- B. The water dump valve energizes for 45 seconds to dump the wash water down the drain.

2. Rinse Cycles (Step 2A and 2B repeated 6 times)

(13 minutes, 30 seconds)

- A. The water pump circulates water over the evaporator for 90 seconds.
- B. The water dump valve energizes for 45 seconds to dump the rinse water down the drain.

3. Changing Switch Position Prior to Completion of Automatic Cleaning Mode

- A. If the toggle switch is turned off prior to dispensing the cleaner or sanitizer, then switched to:
 - a. Ice Making position, normal ice making begins.
 - b. Clean position, a manual start of automatic cleaning mode begins.
- B. If the switch is turned off after the cleaner or sanitizer is dispensed, then switched to:
 - a. Ice Making position, the rinse cycles portion (Step 2A and 2B) of the automatic cleaning mode begins. The ice machine resumes normal ice making operation when rinsing is complete.

NOTE

Each time you turn the switch off and back to ice making, the 6 rinse cycles begin again.

- b. Clean position, a manual start of automatic cleaning mode begins.

REMOVAL OF PARTS FOR CLEANING/SANITIZING

IMPORTANT

These instructions are for B450, B600, B800 and B1000. Other models are typical to these although may vary slightly.

Water Dump Valve Operation Check

1. Remove the top and right side panels.
2. Set the ICE/OFF/CLEAN switch to ICE.
3. Check the dump valve's clear plastic outlet drain hose (refer to illustration) for leakage while the ice machine is in the freeze mode.
4. If the dump valve is leaking, remove; disassemble and clean it.
5. Do not remove the dump valve if it is not leaking. Follow the normal cleaning procedures.

Water Dump Valve Removal

WARNING

Disconnect the electric power to the ice machine at the electric service switch box.

1. Remove the water dump valve shield from its mounting bracket (if applicable).
2. Lift and slide the coil retainer cap from the top of the coil.
3. Leaving the wires attached, lift the coil assembly off of the valve body (enclosing tube). Note the position of the coil assembly on the valve before removing it. Make sure the coil is in the same position when reassembling the valve.
4. Press the enclosing tube's plastic nut down and rotate it 1/4 turn. Remove the enclosing tube, plunger and plastic gasket from the valve body.

The water dump valve can easily be cleaned at this point, without removing the entire valve body.

You do not need to remove the spring from the plunger when cleaning. If the spring is removed, insert the spring's **flared** end into the slotted opening in the top of the plunger, until it comes in contact with the plunger spring stop. Do not stretch or damage the spring when cleaning.

IMPORTANT

The plunger and the inside of enclosing tube must be thoroughly dry before reassembling.

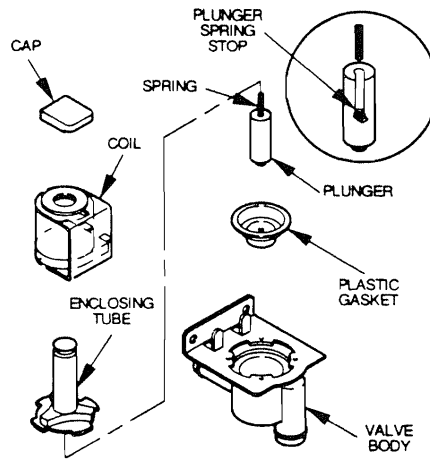

DUMP VALVE DISASSEMBLY

5. Remove the valve body.
 - a. Remove the tubing from the dump valve by twisting the clamps off.
 - b. Remove the two screws securing the dump valve and the mounting bracket.

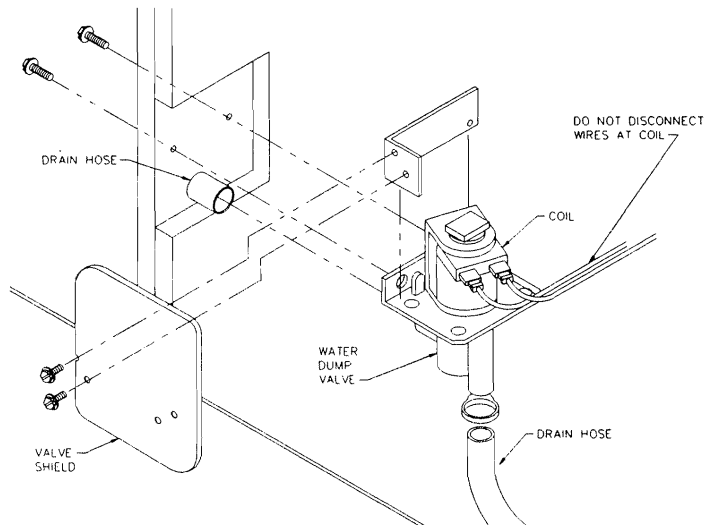

SV1218

DUMP VALVE REMOVAL

Water Pump Removal

1. Disconnect the water pump power cord.

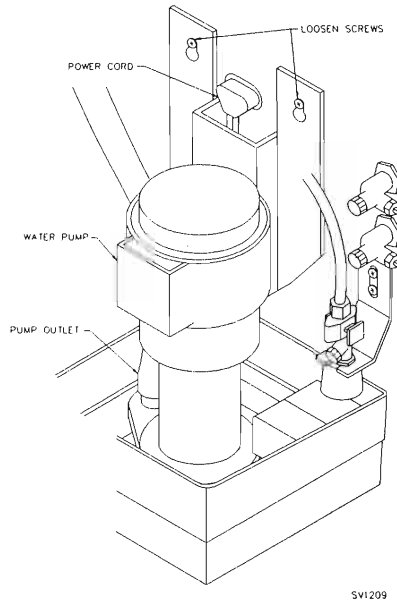

WATER PUMP REMOVAL

2. Disconnect the hose from the pump outlet.
3. Loosen the two screws which hold the pump mounting bracket to the bulkhead.
4. Lift the pump and bracket assembly off screws.

Ice Thickness Probe Removal

1. Remove the ice thickness probe by compressing the side of the probe near the top hinge pin and removing it from the bracket.

NOTE

The ice thickness probe can easily be cleaned at this point without proceeding to Step 2.

WARNING

Disconnect the electric power to ice machine at the electric service switch box before proceeding.

2. If complete removal is required, disconnect the wire leads from the unitized sensor board inside the electrical control box.

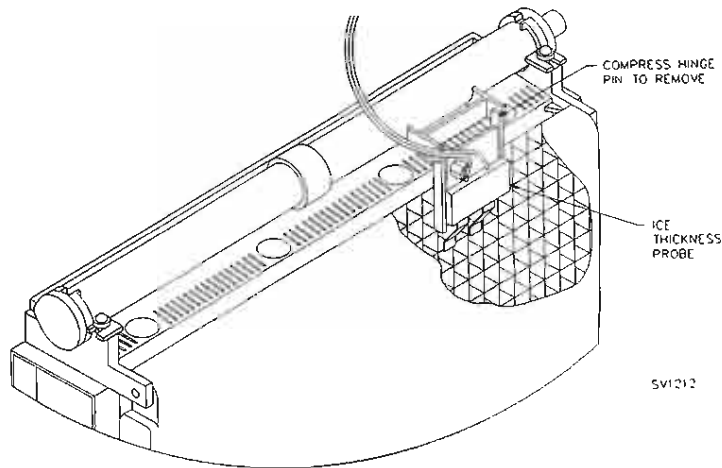

ICE THICKNESS PROBE REMOVAL

Water Trough Removal

1. Remove the screws holding the sump trough in place.
2. Lower the right side of the trough into the bin.
3. Disengage the left side of the trough from its holding pegs and remove the trough from the ice machine.

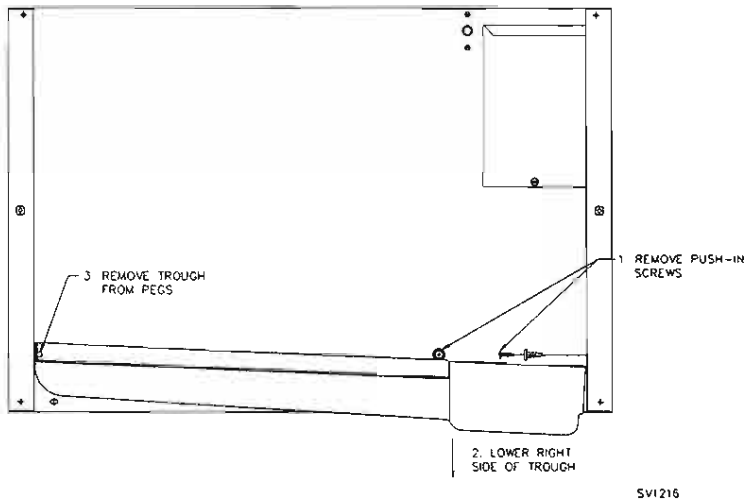

WATER TROUGH REMOVAL

Float Valve Removal

1. Turn the valve splash shield counter-clockwise one or two turns. Pull the valve forward, off the mounting bracket.
2. Disconnect the water inlet tube from the float valve at the compression fitting.
3. Remove the filter screen and cap for cleaning.

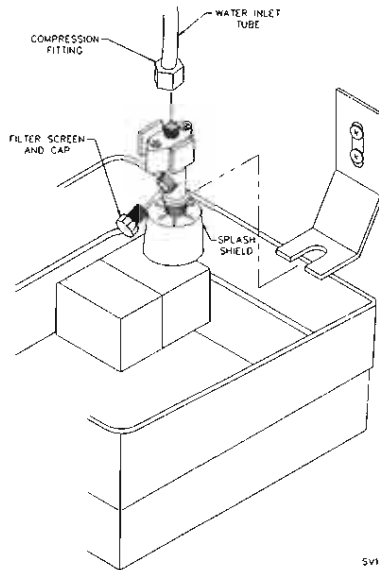

SV1217

FLOAT VALVE REMOVAL

Water Distribution Tube Removal

1. Disconnect the water hose from the distribution tube.
2. Loosen the two thumbscrews which hold the distribution tube in place.
3. Lift the right side up to clear the locating pin, then slide it back and to the right.

IMPORTANT

Do not force this removal. Be sure the locating pin clears the hole before sliding it out.

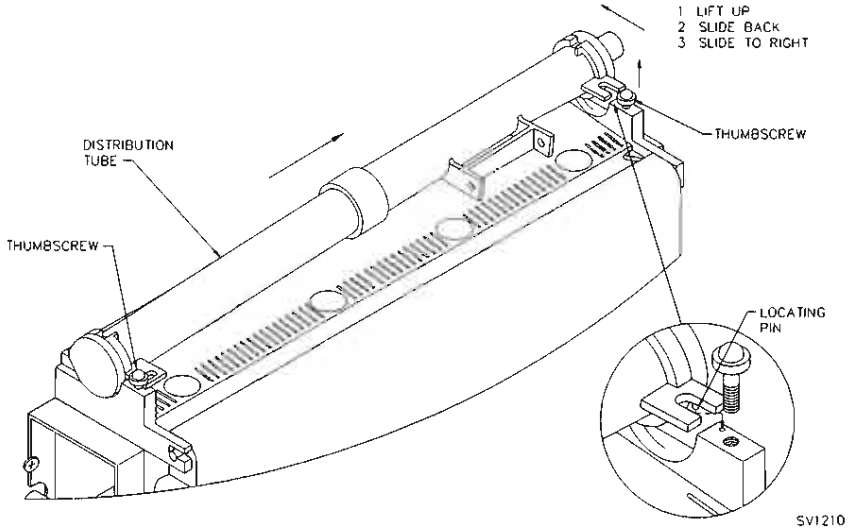

SV1210

WATER DISTRIBUTION TUBE REMOVAL

4. Disassemble for cleaning.
 - a. Twist both of the inner tube ends until the tabs line up with the keyways.
 - b. Pull the inner tube ends outward.

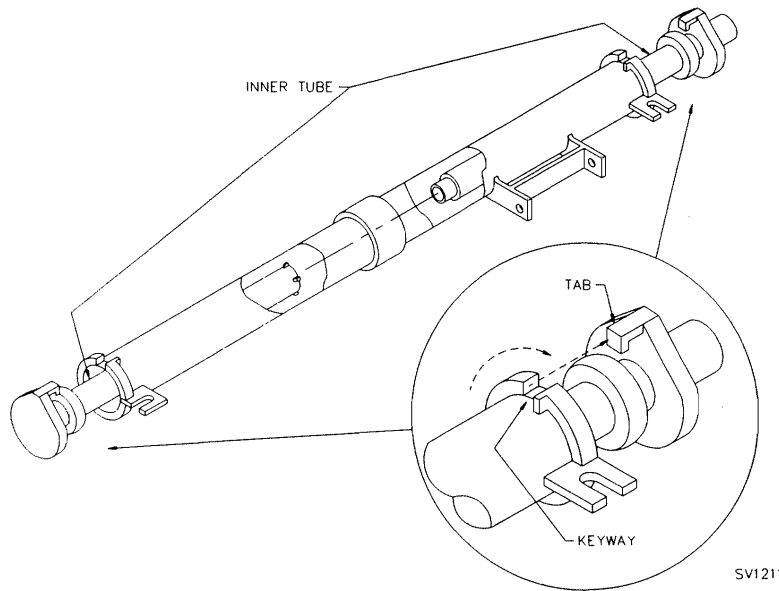

WATER DISTRIBUTION TUBE DISASSEMBLY

Water Curtain Removal

1. Lift the right pin up and out of the bracket.
2. Slide the left pin out.

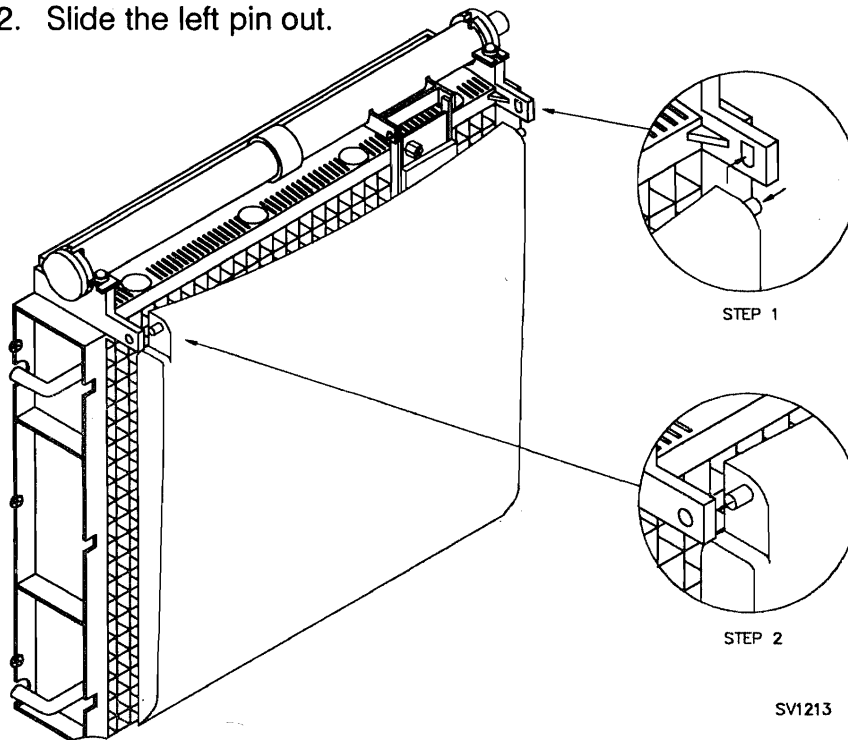

WATER CURTAIN REMOVAL

WATER TREATMENT/FILTRATION

Local water conditions may require the installation of water treatment to inhibit scale formation, filter sediment, and remove chlorine taste and odor. Consult your local dealer or distributor for information on Manitowoc's full line of Tri-Liminator filtration systems.

Replace the primary filter cartridge every six months to ensure maximum filtration efficiency. The filter gauge indicates if earlier replacement is necessary (below 20 psig).

Tri-Liminator systems include a prefilter and should not require primary filter replacement prior to six months usage. If replacement is needed, replace the prefilter first.

Replacement Procedure

1. Turn off the water supply using the inlet shut-off valve.
2. Depress the pressure release button to relieve pressure.
3. Unscrew the housing from the cap (refer to illustration).
4. Remove the used cartridge from the housing and discard.

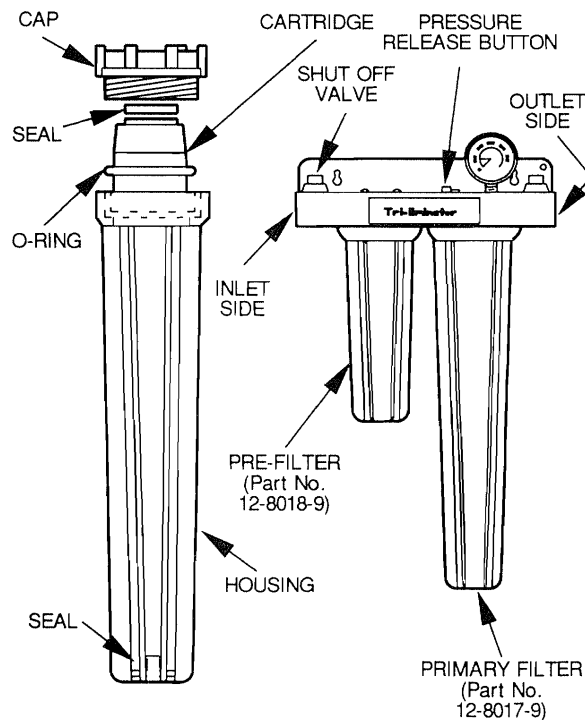

WATER FILTRATION

5. Remove the O-ring from the groove in the housing and wipe the groove and O-ring clean. Relubricate the O-ring with a coating of clean petroleum jelly (Vaseline). Replace the O-ring and press it down into the groove with two fingers.
6. Insert a new cartridge into the housing. Make sure that it slips down over the housing standpipe.
7. Screw the housing onto the cap and **hand tighten. Do not over-tighten or use spanner wrench.**
8. Repeat steps 3 through 7 for each filter housing.
9. Turn on the water supply to allow the housing (and filter) to slowly fill with water.
10. Depress the pressure release button to release trapped air from the housing. Check for leaks.

REMOVAL FROM SERVICE/WINTERIZATION

You must take special precautions if the ice machine is to be removed from service for extended periods, or exposed to ambient temperatures of 32°F (0°C) or below.

CAUTION

If water is allowed to remain in the ice machine in freezing temperatures, severe damage to some components could result. Damage of this nature is not covered by warranty.

Self-Contained Air-Cooled Machines

1. Disconnect the electric power at the circuit breaker or the electric service switch.
2. Turn off the water going to the ice machine.
3. Remove the water from the sump trough.
4. Disconnect the incoming ice making water line, and drain the line at the rear of the ice machine.
5. Blow compressed air in both the incoming water and drain openings (in the rear of the machine) until no more water comes out of the float valve and drain.
6. Be sure no water is trapped in any of the machine's water lines, drain lines, distribution tubes, etc.

Water-Cooled Machines

1. Perform all the procedures listed under "Self-Contained Air-Cooled Machines" above.
2. Disconnect the incoming water and drain lines from the water-cooled condenser.
3. Pry open the water regulating valve by inserting a large standard screwdriver between the bottom spring coils of the valve. Pry the spring upward to open the valve (refer to illustration).
4. Hold the valve open and blow compressed air through the condenser until no water remains.

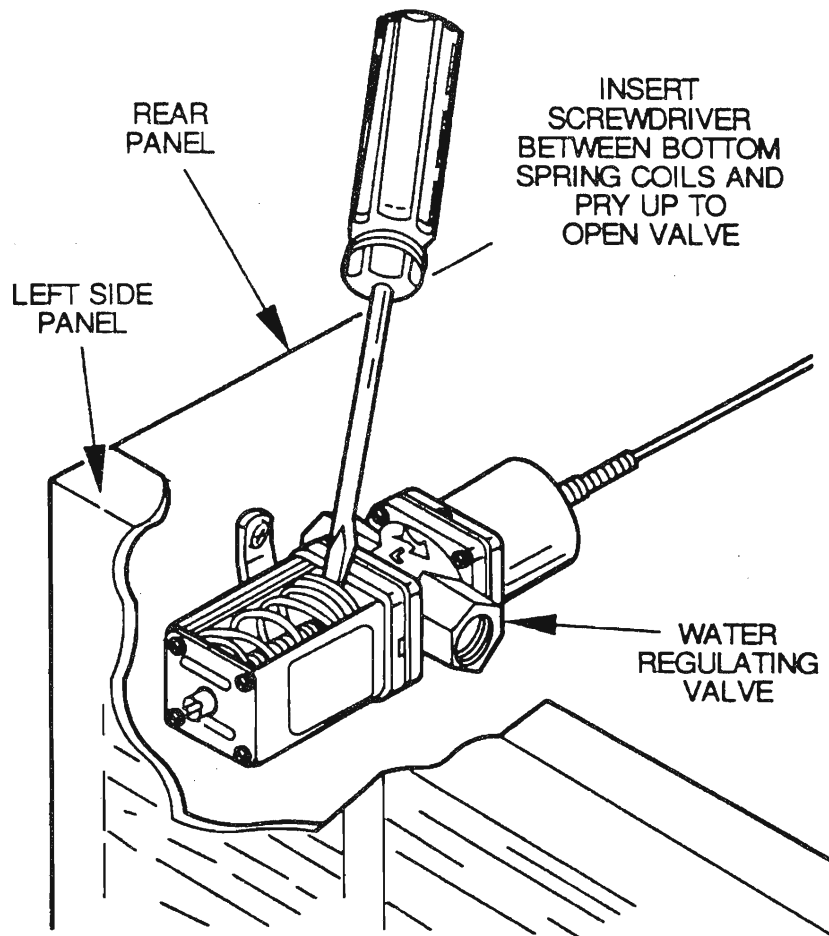

**MANUALLY OPEN
WATER REGULATING VALVE**

Remote Machines

1. Turn the ICE/OFF/CLEAN switch to OFF to allow the ice machine to "pump down" the refrigeration system.
2. Frontseat (shut off) the receiver service valve. (Hang a tag by the toggle switch as a reminder to open the receiver service valve before restarting.)
3. Perform all the procedures listed under "Self-Contained Air-Cooled Machines."

Automatic Cleaning System (AuCS™) Accessory

Refer to the AuCS™ Accessory Installation-Owner/Operator Use and Care Guide for Winterization of AuCS™ Accessory.

SEQUENCE OF OPERATION

B150/B200/B250/B320/B420 B450/B600/B800/B1000 SELF-CONTAINED AIR & WATER-COOLED

Initial Start-up Or Start-up After Automatic Shut-off

1. Prior to the ice machine starting, the water pump and water dump solenoid are energized for 45 seconds to completely purge the water in the sump trough.
2. After the water pump and water dump valve de-energize, the contactor energizes to start the compressor and fan motor. (The fan motor on air-cooled models may cycle on/off through fan cycle control.)

Freeze Sequence

3. The water pump restarts after a 30 second delay period. With the water pump running, an even flow of water is directed across the evaporator and into each cube cell, where it freezes.
4. When sufficient ice has formed, the water flow contacts the ice thickness probe. After approximately seven seconds, the harvest sequence is initiated. The ice machine must be in the freeze cycle for 6 minutes prior to harvest initiation. Refer to "Freeze Time Lock-In" for details.

Harvest Sequence

5.
 - a. The hot gas valve opens diverting hot refrigerant gas into the evaporator.
 - b. The water dump solenoid is energized for 45 seconds to purge the water in the sump trough. After the 45 second purge, the water pump and water dump valve de-energize.
6. The hot refrigerant gas warms the evaporator causing the cubes to slide, as a unit, off the evaporator and into the storage bin. The sliding sheet of cubes swings the water curtain out, activating a bin switch. The momentary opening of the bin switch terminates the harvest sequence and returns the ice machine to the freeze sequence (Steps 3 and 4).

(continued on next page)

Automatic Shut-off

7. At the end of a harvest sequence, if the water curtain is held open for more than 7 seconds, the ice machine will shut off. When the storage bin is full, the last sheet of cubes holds the water curtain open.
8. The ice machine remains off until sufficient ice is removed from the bin allowing ice to clear the water curtain. As the water curtain swings back to operating position, the ice machine restarts (Steps 1 and 2).

SELF CLEANING SYSTEM (SeCS™)

1. The water pump and water dump valve energize to purge water from the sump trough. The dump valve de-energizes after approximately 45 seconds.
2. A 10 minute clean cycle with water running over the evaporator is followed by six rinse cycles. When this process (which lasts approximately 25 minutes) is completed, the cleaning cycle automatically stops.

SEQUENCE OF OPERATION

B1300/B1800 SELF-CONTAINED AIR OR WATER-COOLED

Initial Start-up or Start-up After Automatic Shut-off

1. Prior to the ice machine starting, the water pump and water dump solenoid are energized for 45 seconds to completely purge the water in the sump trough.
2. After the water pump and water dump valve de-energize, the contactor energizes to start the compressor and fan motor. (The fan motor on air-cooled models may cycle on/off through fan cycle control.)

Freeze Sequence

3. The water pump restarts after a 30 second delay period. With the water pump running, an even flow of water is directed across the evaporators and into each cube cell, where it freezes.
4. When sufficient ice has formed, the water flow contacts the ice thickness probe. After approximately seven seconds, the harvest sequence is initiated. The ice machine must be in the freeze cycle for 6 minutes prior to harvest initiation. Refer to "Freeze Time Lock-In" for details.

Harvest Sequence

5.
 - a. The water dump solenoid is energized for 45 seconds to purge the water in the sump trough. After the 45 second purge, the water pump and water dump valve de-energize.
 - b. Both hot gas valves energize (open), diverting hot refrigerant gas into the evaporators.
6.
 - a. The hot refrigerant gas warms each evaporator causing the cubes to slide, as a unit, off each evaporator and into the storage bin. The ice may fall first from either the left or right evaporator, or both at the same time.
 - b. The sliding sheet of cubes swings the water curtain out activating the corresponding bin switch. This momentary opening of the bin switch causes the hot gas valve feeding that evaporator to be de-energized (closed).
 - c. After the momentary opening of both bin switches, the harvest sequence terminates and the ice machine returns to the freeze sequence (Steps 3 and 4).

(continued on next page)

Automatic Shut-off

7. a. At the end of a harvest sequence, if either one or both water curtains are held open by ice for more than 7 seconds, the ice machine will shut off.
8. The ice machine remains off until sufficient ice is removed from the bin allowing ice to clear both water curtains. After both water curtains swing back to operating position, the ice machine restarts (Steps 1 and 2).

SELF-CLEANING SYSTEM (SeCS™)

1. The water pump and water dump valve energize to purge water from the sump trough. The dump valve de-energizes (closes) after approximately 45 seconds.
2. A 10 minute clean cycle with water running over the evaporator is followed by six rinse cycles. When this process (which lasts approximately 25 minutes) is completed, the cleaning cycle automatically stops.

SEQUENCE OF OPERATION

B450/B600/B800/B1000 REMOTE

Initial Start-up Or Start-up After Automatic Shut-off

1. Prior to the ice machine starting, the water pump and water dump solenoid are energized for 45 seconds to completely purge the water in the sump trough.
2. After the water pump and water dump valve de-energize, the liquid line solenoid energizes and the low side pressure rises. The low pressure control closes to energize the contactor which starts the compressor and fan motor.

Freeze Sequence

3. The water pump restarts after a 30 second delay period. With the water pump running, an even flow of water is directed across the evaporator and into each cube cell, where it freezes.
4. When sufficient ice has formed, the water flow contacts the ice thickness probe. After approximately seven seconds, the harvest sequence is initiated. The ice machine must be in the freeze cycle for 6 minutes prior to harvest initiation. Refer to "Freeze Time Lock-In" for details.

Harvest Sequence

5.
 - a. The hot gas valve energizes diverting hot refrigerant gas into the evaporator. The harvest pressure regulating (H.P.R.) solenoid also energizes.
 - b. The water dump solenoid is energized for 45 seconds to purge the water in the sump trough. After the 45 second purge, the water pump and water dump valve de-energize.
6. The hot refrigerant gas warms the evaporator causing the cubes to slide, as a unit, off the evaporator and into the storage bin.

The sliding sheet of cubes swings the water curtain out, activating the bin switch. The momentary opening of the bin switch terminates the harvest sequence and returns the ice machine to the freeze sequence (Steps 3 and 4).

(continued on next page)

Automatic Shut-off

7. When the ice storage bin becomes full, the last sheet of cubes holds the water curtain open. At the end of a harvest cycle, if the bin switch is held open for more than seven seconds, the liquid line solenoid is de-energized. The ice machine will pump down the low side of the system until the low pressure control reaches its cut-out setting, de-energizing the contactor which stops the compressor and fan.
8. The ice machine remains off until sufficient ice is removed from the bin allowing ice to clear the water curtain. As the water curtain swings back to operating position, the ice machine restarts (Steps 1 and 2).

SELF-CLEANING SYSTEM (SeCS™)

1. The water pump and water dump valve energize to purge water from the sump trough. The dump valve de-energizes after approximately 45 seconds.
2. A 10 minute clean cycle with water running over the evaporator is followed by six rinse cycles. When this process (which lasts approximately 25 minutes) is completed, the cleaning cycle automatically stops.

SEQUENCE OF OPERATION

B1300/B1800

REMOTE

Initial Start-up or Start-up After Automatic Shut-off

1. Prior to the ice machine starting, the water pump and water dump solenoid are energized for 45 seconds to completely purge the water in the sump trough.
2. After the water pump and water dump valve de-energize, the liquid line solenoid energizes (opens) and the low side pressure rises. The low pressure control closes to energize the contactor which starts the compressor and fan motor.

Freeze Sequence

3. The water pump restarts after a 30 second delay period. With the water pump running, an even flow of water is directed across the evaporators and into each cube cell, where it freezes.
4. When sufficient ice has formed, the water flow contacts the ice thickness probe. After approximately seven seconds, the harvest sequence is initiated. The ice machine must be in the freeze cycle for 6 minutes prior to harvest initiation. Refer to "Freeze Time Lock-In" for details.

Harvest Sequence

5.
 - a. The water dump solenoid is energized for 45 seconds to purge the water in the sump trough. After the 45 second purge, the water pump and water dump valve de-energize.
 - b. Both hot gas valves energize (open) diverting hot refrigerant gas into the evaporators. The harvest pressure regulating (H.P.R.) solenoid also energizes (opens).
6.
 - a. The hot refrigerant gas warms each evaporator causing the cubes to slide, as a unit, off each evaporator and into the storage bin. The ice may fall from either the left or right evaporator, or both at the same time.
 - b. The sliding sheet of cubes swings the water curtain out activating the corresponding bin switch. This momentary opening of the bin switch causes the hot gas valve feeding that evaporator to de-energize (close).
 - c. After the momentary opening of both bin switches, the harvest sequence terminates and the ice machine returns to the freeze sequence (Steps 3 and 4).

(continued on next page)

Automatic Shut-off

7. a. At the end of a harvest sequence, if either one or both water curtains are held open by ice for more than 7 seconds, all control board contacts open and the ice machine shuts off.
 - b. After either bin switch (or both) is held open for more than 7 seconds, the control board de-energizes (closes) the liquid line solenoid. The ice machine will pump down the low side of the system until the low pressure control reaches its cut-out setting and opens. This de-energizes the contactor, stopping the compressor and fan.
8. The ice machine remains off until sufficient ice is removed from the bin allowing ice to clear both water curtains. After both water curtains swing back to operating position, the ice machine restarts (Steps 1 and 2).

SELF CLEANING SYSTEM (SeCS™)

1. The water pump and water dump valve energize to purge water from the sump trough. The dump valve de-energizes (closes) after approximately 45 seconds.
2. A 10 minute clean cycle with water running over the evaporator is followed by six rinse cycles. When this process (which lasts approximately 25 minutes) is completed, the cleaning cycle automatically stops.

ELECTRICAL SYSTEM

BIN SWITCH

Function

Bin switch operation is controlled by movement of the water curtain and has two functions:

1. The momentary opening of the bin switch terminates the harvest sequence and returns the ice machine to the freeze sequence.
2. Automatic ice machine shut off. The bin switch can be opened and closed at any point during the freeze cycle without interfering with the electrical control sequence. At the end of a harvest sequence, when the storage bin is full, the last sheet of cubes hold the water curtain open. When the bin switch is held open for more than 7 seconds, the ice machine will shut off.

The ice machine remains off until sufficient ice is removed from the bin allowing ice to clear the water curtain. As the water curtain swings closed, the bin switch recloses and the ice machine starts another freeze cycle.

Specifications

The bin switch is a magnetically operated reed switch. The magnet is attached to the lower right hand corner of the water curtain, the switch portion is attached to the evaporator mounting bracket.

The bin switch is connected into a "varying" D.C. voltage circuit. (Voltage does not remain constant.)

NOTE

Because of a wide variation in D.C. voltage, it is not recommended that a voltmeter be used to check bin switch operation.

Check Procedure

1. Place the toggle switch in the OFF position.
2. Watch bin switch light (bottom one) on the unitized ice sensor board.
3. With the water curtain toward the evaporator, the switch must close. The light "on" indicates the switch properly closed.

(Continued on next page)

4. With the water curtain pulled away from the evaporator, the switch must open. The light "off" indicates the switch opened properly.

NOTE

Bin switch may also be checked by isolating from other components and using ohmmeter.

Water Curtain Removal

The water curtain(s) can be removed and replaced at any point during the freeze cycle without interfering with the electrical control sequence. If the ice machine goes into harvest while the curtain is removed, one of the following will happen:

- a. Water curtain remains off - Single or Dual Evaporator:

When the harvest cycle time reaches 3.5 minutes and the bin switch is not reclosed, the ice machine stops as though the bin is full.

- b. Water curtain put back on:

Single evaporator: If the bin switch recloses prior to reaching the 3.5 minute point, the ice machine immediately returns to another freeze sequence.

Dual evaporator: If the bin switch recloses prior to reaching the 3.5 minute point, the hot gas valve feeding the corresponding evaporator will de-energize (close).

NOTE

When the ice machine cycles into harvest with the water curtain removed, it is normal for the harvest light to turn off and remain off even though the ice machine remains in the harvest cycle.

DIAGNOSING COMPRESSOR (AND START COMPONENTS) ELECTRICAL FAILURES

Compressor will not start or will trip repeatedly on overload.

A. CHECK RESISTANCE (OHM) VALUES

Compressors winding can have very low OHM values. The use of properly calibrated meter is recommended.

The resistance test is done after the compressor is cool. The compressor dome should be cool enough to touch (approximately 120°F/48.9°C) to assure overload is closed and resistance readings will be accurate.

1. Single phase compressors

- a. Disconnect power to cuber; wires from compressor terminals.
- b. With wires removed, the resistance values must be within guidelines for the compressor. The resistance value from C to S and C to R added together, should equal value from S to R.
- c. An open overload will give a resistance reading from S to R and an "Open" reading from C to S and C to R. Allow the compressor to cool, then recheck readings.

2. Three phase compressors

- a. Disconnect power to cuber; remove wires from compressor terminals.
- b. With wires removed, the resistance values must be within guidelines for the compressor. L1 to L2; L2 to L3; and L1 to L3, should all be equal to each other.
- c. An open overload will give a resistance reading of "Open" from L1 to L2; L2 to L3; and L1 to L3. Allow compressor to cool, then recheck reading.

B. CHECK MOTOR WINDINGS TO GROUND

Check continuity between all three terminals and the compressor shell or copper refrigeration line (be sure to scrape metal surface clean to get good contact). If continuity is present, the compressor windings are grounded and the compressor should be replaced.

C. DETERMINE IF THE COMPRESSOR IS "SEIZED"
Check amp draw while compressor is trying to start.

1. Compressor drawing locked rotor, the two likely causes would be a defective starting component or a mechanically seized compressor. To determine which you have:
 - a. Install high and low side gauges.
 - b. Try to start compressor (watch pressures closely).
 - c. If pressures do not move, compressor is seized up. Replace compressor.
 - d. If pressures move, the compressor is turning slowly and is not seized. Check capacitors and start relay.
2. Compressor drawing high amps
The continuous amperage draw on start-up should not near the maximum fuse size as indicated on the serial tag.
Check the following:
Low voltage — The voltage at the time the compressor is trying to start must be within $\pm 10\%$ of the nameplate voltage.

D. DIAGNOSING CAPACITORS AND RELAYS

1. Capacitors

If the compressor attempts to start, or hums and trips the overload protector, you must check the starting components before replacing a compressor.

- a. Capacitors can show visual evidence of failure, such as a bulged terminal end or a ruptured membrane. **Do not assume a capacitor is good** if no visual signs are evident.
- b. A good test is to install a known good substitute capacitor.
- c. Use of a capacitor tester is recommended when checking a suspect capacitor. Remember to clip the bleed resistor off the capacitor terminals before testing.

2. Relays

Potential type:

Potential relay contacts are closed during the initial starting cycle, and open as the compressor comes up to speed.

Check Procedure

- a. Disconnect power supply.
- b. Remove wires from relay.
- c. Use a high voltage OHM meter to check the relay coil — open — replace; continuity — ok.
- d. Use an OHM meter to check across the contacts. Potential relay contacts are normally closed.

Current type:

Current relay contacts are normally open.

Check Procedure

- a. Disconnect power supply.
- b. If relay is on the compressor, pull off.
- c. Keeping relay upright, check continuity with OHM meter. Closed — replace.

NOTE

Turning relay upside down will give a closed reading.

- d. Check continuity through relay coil, replace if no continuity.

MANITOWOC B-MODEL ICE MACHINE COMPRESSORS

Winding OHM Values

| Ice Machine | Compressor Part Number | Compressor Model Number | Voltage/ Cycle/Phase | 1PH | | C-S | | C-R | | R-S | | Locked Rotor Amps | Oil Charge (Oz.) |
|-------------|------------------------|-------------------------|-------------------------|-------------|-------------|-------------|-------|-------|--|-----|--|-------------------|------------------|
| | | | | 3 PH | T1—T2 | T1—T3 | T1—T3 | T2—T3 | | | | | |
| B150 | 84-0122-3 | AK9428E | 115/60/1 | 4.50 - 4.60 | 0.68 - 0.69 | 5.18 - 5.29 | 48 | 15 | | | | | |
| B200 | 84-0143-3 | AK9428E | 208—230/60/1 | 6.23 | 2.75 | 8.98 | 23 | 15 | | | | | |
| B250 | 84-0127-3 | AK9428E | 220—240/50/1 | 7.13 | 3.15 | 10.28 | 21 | 15 | | | | | |
| B320 | 84-0122-3 | AK9428E | 115/60/1 | 4.50 - 4.60 | 0.68 - 0.69 | 5.18 - 5.29 | 48 | 15 | | | | | |
| | 84-0143-3 | AK9428E | 208—230/60/1 | 6.23 | 2.75 | 8.98 | 23 | 15 | | | | | |
| | 84-0127-3 | AK9428E | 220—240/50/1 | 7.13 | 3.15 | 10.28 | 21 | 15 | | | | | |
| B420 | 84-0189-3 | AK170JT-039-A4D | 115/60/1 | 5.95 | 0.69 | 6.64 | 50 | 17 | | | | | |
| B450 | 84-0190-3 | AK170JT-039-A4D | 208—230/60/1 | 10.43 | 1.77 | 12.20 | 31 | 17 | | | | | |
| | 84-0191-3 | AK170JT-039-A4D | 220—240/50/1 | 7.15 | 2.75 | 9.90 | 26 | 17 | | | | | |
| B600 | 84-0215-3 | RS86C1E-PFJ-218 | 208—230/60/1 | 4.1 - 4.7 | 1.4 - 1.6 | 5.5 - 6.3 | 43 | 24 | | | | | |
| | 84-0216-3 | RS86C1E-PFJ-218 | 220—240/50/1 | 4.4 - 5.1 | 2.3 - 2.6 | 6.6 - 7.7 | 36 | 24 | | | | | |
| B800 | 84-0201-3 | AWA7512ZXD | 208—230/60/1 | 1.96 | 0.88 | 2.84 | 73 | 38 | | | | | |
| | 84-0202-3 | AWA7512ZXT | 208—230/60/3 | 1.28 | 1.28 | 1.28 | 63 | 38 | | | | | |
| | 84-0203-3 | AWA7512ZXC | 220—240/50/1 | 2.55 | 1.15 | 3.70 | 65 | 38 | | | | | |

(continued)

MANITOWOC B-MODEL ICE MACHINE COMPRESSORS (Continued)

Winding OHM Values

| Ice Machine | Compressor Part Number | Compressor Model Number | Voltage/ Cycle/Phase | 1PH C-S | | C-R | | R-S | | Locked Rotor Amps | Oil Charge (Oz.) |
|-------------|------------------------|-------------------------|-------------------------|---------|-------|-------|-------|-------|--|-------------------|------------------|
| | | | | 3 PH | T1—T2 | T1—T3 | T1—T3 | T2—T3 | | | |
| B1000 | 84-0204-3 | AWA7515ZXD | 208—230/60/1 | 3.25 | | 0.59 | | 3.84 | | 97 | 38 |
| | 84-0205-3 | AWA7515ZXT | 208—230/60/3 | 1.28 | | 1.28 | | 1.28 | | 63 | 38 |
| | 84-0206-3 | AWA7515ZXC | 220—240/50/1 | 2.49 | | 0.81 | | 3.30 | | 83 | 38 |
| B1300 | 84-0221-3 | AVA7524ZXW | 208—230/60/1 | 1.67 | | 0.42 | | 2.09 | | 124 | 55 |
| | 84-0222-3 | AVA7524ZXT | 208—230/60/3 | 1.58 | | 1.58 | | 1.58 | | 65 | 55 |
| | 84-0223-3 | AVA7524ZXC | 220—240/50/1 | 2.14 | | .68 | | 2.82 | | 102 | 55 |
| | 84-0224-3 | AVA7524ZXC | 415/50/3 | 3.43 | | 3.43 | | 3.43 | | 38 | 55 |
| B1800 | 84-0211-3 | AVA7528ZX | 208—230/60/1 | 1.67 | | 0.42 | | 2.09 | | 124 | 55 |
| | 84-0212-3 | AVA7528ZXT | 208—230/60/3 | 0.858 | | 0.858 | | 0.858 | | 79 | 55 |
| | 84-0213-3 | AVA7528ZXC | 220—240/50/1 | 2.14 | | .68 | | 2.82 | | 101 | 55 |
| | 84-0214-3 | AVA7528ZXC | 415/50/3 | 3.43 | | 3.43 | | 3.43 | | 38 | 55 |

DISCHARGE LINE THERMISTOR

Function

Senses the compressor discharge line temperature. This is used in conjunction with the unitized ice sensor safety limits to stop the ice machine if discharge line temperature falls below 85°F (29.4°C) or above 255°F (123.9 °C).

Specifications

100,000 Ohms +/- 2% @ 77°F (25°C)

IMPORTANT

Use only Manitowoc thermistors.

Thermistors generally fail because of moisture or physical damage. Manitowoc B-Model discharge line thermistors are encased in a specially designed, moisture sealed, aluminum block. This eliminates physical damage and moisture related concerns.

Check Procedure

Verify that the thermistor resistance is accurate and corresponding to both high and low temperature ranges.

Step 1. Disconnect discharge line thermistor from terminals 1A and 1B on unitized ice sensor board. Connect ohm meter to isolated thermistor wire leads.

Step 2. Using a quality temperature meter capable of taking readings on curved copper lines, attach temperature meter sensing device to compressor discharge line next to thermistor aluminum block.

IMPORTANT

Do not simply "insert" probe (or other sensing device) under insulation. It must be "attached to" and reading the **actual** temperature of the copper compressor discharge line.

Step 3. With the ice machine running, verify the thermistor resistance (Step 1) corresponds to the temperature of the thermistor block on the Compressor Discharge Line (Step 2). It is normal for the Compressor Discharge Line temperature to rise during the freeze cycle and lower during the harvest cycle. Use the freeze cycle to verify that thermistor is accurate at higher temperatures and the harvest cycle to verify it is accurate at lower temperatures.

NOTE

If ice machine is inoperable, the thermistor may be removed and placed for a short period of time in an ice bath and then in boiling water to verify accuracy.

Discharge Line Thermistor Temperature/Resistance

As the temperature Rises at the thermistor "block", the resistance Drops:

| Temperature (of thermistor "block") | | Resistance |
|----------------------------------------|----------------------|-----------------|
| °F | °C | K ohms (x 1000) |
| 32° | 0° (Ice Bath) | 376.7 - 283.6 |
| 50° - 60° | 10.0° - 15.6° | 198.9 - 153.1 |
| 60° - 70° | 15.6° - 21.1° | 153.1 - 118.8 |
| 70° - 80° | 21.1° - 26.7° | 118.8 - 92.9 |
| 80° - 90° | 26.7° - 32.2° | 92.9 - 73.3 |
| 90° - 100° | 32.2° - 37.8° | 73.3 - 58.2 |
| 100° - 110° | 37.8° - 43.3° | 58.2 - 46.6 |
| 110° - 120° | 43.3° - 48.9° | 46.6 - 37.5 |
| 120° - 130° | 48.9° - 54.4° | 37.5 - 30.5 |
| 130° - 140° | 54.4° - 60.0° | 30.5 - 24.9 |
| 140° - 150° | 60.0° - 65.6° | 24.9 - 20.4 |
| 150° - 160° | 65.6° - 71.1° | 20.4 - 16.8 |
| 160° - 170° | 71.1° - 76.7° | 16.8 - 14.0 |
| 170° - 180° | 76.7° - 82.2° | 14.0 - 11.7 |
| 180° - 190° | 82.2° - 87.8° | 11.7 - 9.8 |
| 190° - 200° | 87.8° - 93.3° | 9.8 - 8.2 |
| 200° - 210° | 93.3° - 98.9° | 8.2 - 7.0 |
| 212° | 100° (boiling water) | 7.3 - 6.2 |
| 220° - 230° | 104.4° - 110.0° | 5.9 - 5.1 |
| 230° - 240° | 110.0° - 115.6° | 5.1 - 4.3 |
| 240° - 250° | 115.6° - 121.1° | 4.3 - 3.7 |
| 250° - 260° | 121.1° - 126.7° | 3.7 - 3.3 |

IMPORTANT

If ohm meter reads "O.L.", check "scale setting" on meter before changing thermistor.

ICE/OFF/CLEAN TOGGLE SWITCH

Function

To place ice machine in ICE, OFF, or CLEANING mode of operation.

Specifications

Double pole, double throw switch

The toggle switch is connected into a "varying" low D.C. voltage circuit. (Voltage does not remain constant.)

Check Procedure

NOTE

Because of a wide variation in D.C. voltage, it is not recommended that a voltmeter be used to check toggle switch operation.

1. Inspect toggle switch for correct wiring.
2. Isolate toggle switch from other components by disconnecting all wires from switch.
3. Check across toggle switch terminals using a calibrated ohmmeter. Correct readings should be as follows:

a. Switch set at ICE:

| <u>Terminals</u> | <u>OHM reading</u> |
|------------------|--------------------|
| 66-62 | Open |
| 67-68 | Closed |
| 67-69 | Open |

b. Switch set at CLEAN:

| <u>Terminals</u> | <u>OHM reading</u> |
|------------------|--------------------|
| 66-62 | Closed |
| 67-68 | Open |
| 67-69 | Closed |

c. Switch set at OFF:

| <u>Terminals</u> | <u>OHM reading</u> |
|------------------|--------------------|
| 66-62 | Open |
| 67-68 | Open |
| 67-69 | Open |

Replace toggle switch if OHM readings do not match all three switch settings.

SINGLE EVAPORATOR CONTROL BOARD

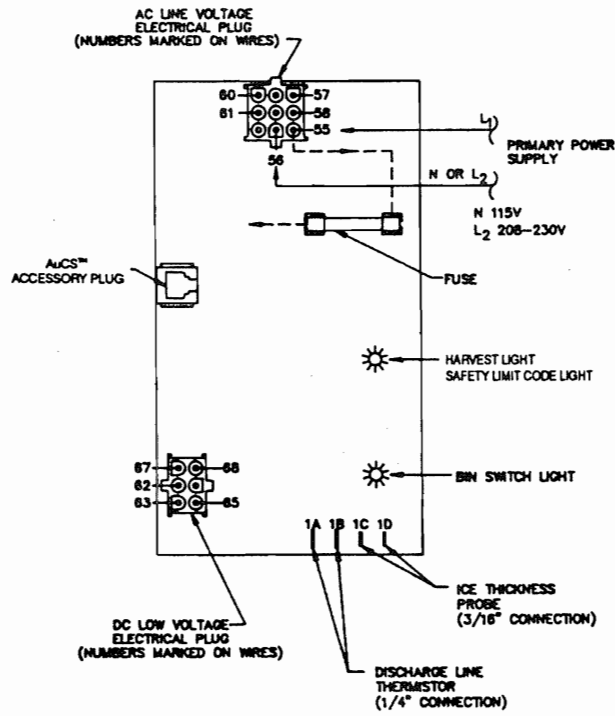

SV 1219

DUAL EVAPORATOR CONTROL BOARD

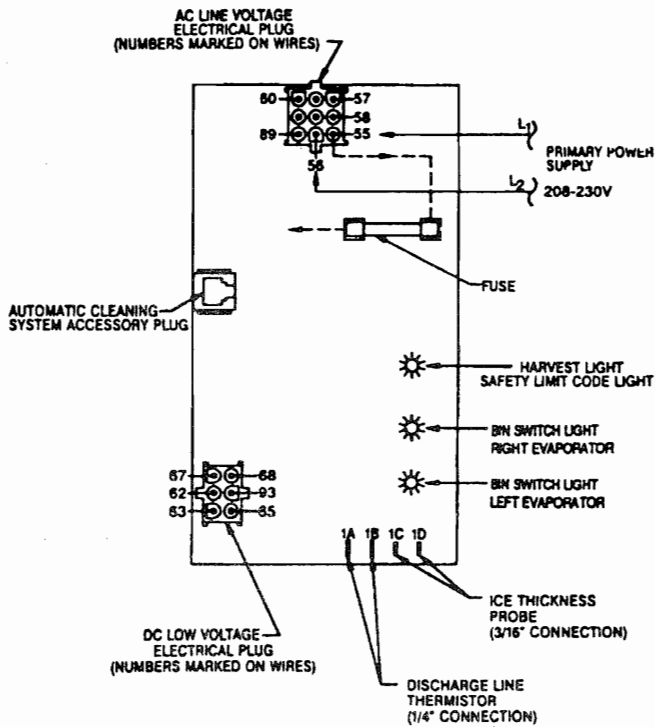

SV 1345

FIELD REPLACEMENT CONTROL BOARD

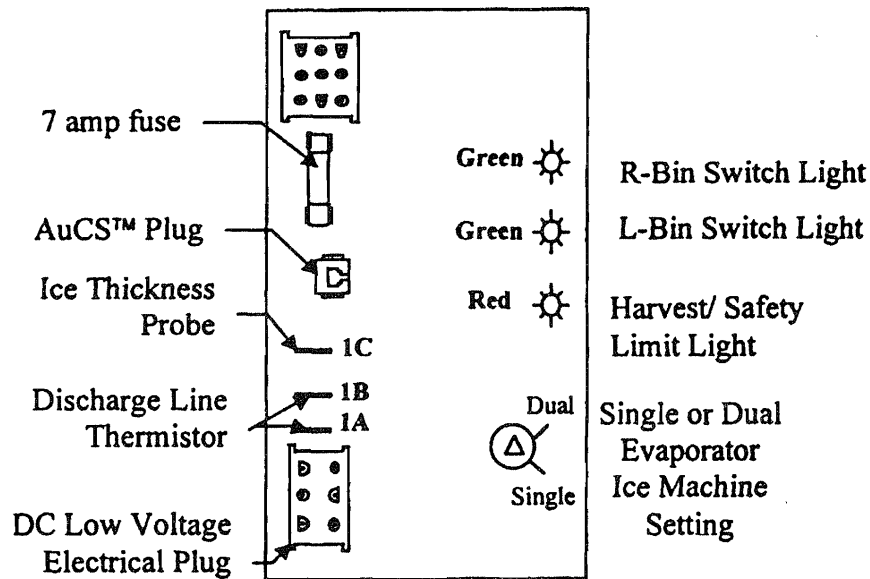

The New B Model Control Board Incorporates the Following Improvements:

DUAL VOLTAGE TRANSFORMER:

- One control board **works on all B model** ice machines. Single or Dual evaporator and all voltages.

DIRECT REPLACEMENT WITH OLD:

- Electrical Ice Making and Cleaning sequence is identical to the original circuit board. No wiring changes necessary to install into existing B model ice machines.

SINGLE/DUAL EVAPORATOR SETTING:

- Set at *Single* when installing into any single evaporator ice machine or to *Dual* when installing into B1300 or B1800 ice machines.

SINGLE PROBE ICE THICKNESS CONTROL:

- **The single probe design must be used with the new control board.** When installing a replacement circuit board, a single style probe must also be installed. The single style probe is used for field replacement with ALL B Model Ice Machine control boards.

IMPORTANT

When installing a replacement circuit board, a single style Ice Thickness Control must be used. Dual Probe Ice Thickness Controls will not work with the replacement circuit board.

CONTROL BOARD (UNITIZED ICE SENSOR BOARD)

1. General

The control board controls all electrical components including the ice machine sequence of operation. **Prior to diagnosing**, you must understand how this board functions (what it is supposed to do).

Refer to wiring diagrams and ice machine sequence of operation sections for details including:

- a. Initial start-up or start-up after auto shut off mode
- b. Freeze sequence
- c. Harvest sequence
- d. Automatic shut-off
- e. Self-cleaning

2. Harvest Initiation (ice thickness probe)

Manitowoc's patented solid state electronic sensing circuit which does not rely on the refrigeration system (pressure), temperature of evaporator, or timers, assures consistent ice formation. The ice machine must be in the freeze cycle for 6 minutes prior to harvest initiation. Refer to "Freeze Time Lock-In" for details.

As the ice forms outward on the evaporator, water will contact the ice thickness probes. After the water completes this circuit across the probes continually for 6-10 seconds, a harvest cycles is initiated.

3. L.E.D. Lights

Bin Switch Light (s)

The light is ON when the bin switch (water curtain) is closed, and OFF when the bin switch is open. Dual evaporator ice machines have two of these lights.

This light functions anytime power is supplied to the ice machine, even when the toggle switch is in the OFF or CLEAN position. This feature indicates the primary power supply (line voltage) at the control board is okay, without having to take a voltage reading.

Harvest Light/ Safety Limit Light

Its primary function is to be on as water contacts the ice thickness probe and remains on throughout the complete harvest cycle. The light will flicker as water splashes on the probes.

Its secondary function is to continually flash when the ice machine is shut off on a safety limit and to indicate which safety limit shut off the ice machine.

4. **Freeze Time “Lock-in” Feature**

This feature protects the ice machine from short cycling in and out of harvest.

The control board locks the ice machine in the freeze cycle for 6 minutes. If water contacts the ice thickness probes during the first 6 minutes of the freeze cycle, the harvest light will come on (to indicate water is in contact with the probes), but the ice machine stays in the freeze cycle. After the 6 minutes “lock-in” time is reached, a harvest cycle will be initiated.

To allow the service technician to initiate a harvest without delay, this feature is not used on the first cycle after turning the toggle switch off and then back to ice making position.

5. **Water Curtain Removal**

The water curtain(s) can be removed and replaced at any point during the freeze cycle without interfering with the electrical control sequence. If the ice machine goes into harvest while the curtain is removed, one of the following will happen:

a. Water curtain remains off - Single or Dual Evaporator:

When the harvest cycle time reaches 3.5 minutes and the bin switch is not reclosed, the ice machine stops as though the bin is full.

b. Water curtain put back on:

Single evaporator: If the bin switch recloses prior to reaching the 3.5 minute point, the ice machine immediately returns to another freeze sequence.

Dual evaporator: If the bin switch recloses prior to reaching the 3.5 minute point, the hot gas valve feeding the corresponding evaporator will de-energize (close).

NOTE

When the ice machine cycles into harvest with the water curtain removed, it is normal for the harvest light to turn off and remain off even though the ice machine remains in the harvest cycle. (Original production board only.)

(continued on next page)

6. 7 Amp Fuse

Function

This fuse stops the entire ice machine operation if electrical components fail causing high amp draw.

Specifications: 250V, 7 Amp

Check Procedure:

DANGER

High (line) voltage is applied to the control board (pin connector terminals #55 and #56) at all times. Removing 7 amp fuse or placing the toggle switch in OFF position will not remove power supplied to the control board.

Step 1. If bin switch light(s) is(are) on with water curtain closed, the 7 amp fuse is okay.

DANGER

Disconnect electrical power to entire ice machine before proceeding.

Step 2. Remove fuse. Using an ohmmeter, check the resistance across removed fuse.

- a. Open (OL) reading - replace fuse
- b. Closed (O) reading - fuse is okay

7. Safety Limits

In addition to standard safety controls such as high pressure cut-out, the control board has four built-in safety limits which protect the ice machine from major component failures.

Refer to safety limits, page 98, for further information.

DIAGNOSING ELECTRICAL CONTROL CIRCUITRY

I. ICE MACHINE WILL NOT RUN

DANGER

High (line) voltage is applied to the control board (pin connector terminals #55 and #56) at all times. Removing ice machine's 7 amp fuse or placing the toggle switch in off position will not remove the power to the control board.

| Step | Check in Order: | Notes |
|------|--------------------------------------------------------|------------------------------------------------------------------------------------------------------------------------------------|
| 1 | Verify primary voltage supply to ice machine. | Verify that the fuse or circuit breaker is closed. |
| 2 | Verify the high pressure cut-out is closed. | The high pressure cut-out is closed if primary power voltage is present at pin connector (on control board) terminals #55 and #56. |
| 3 | Verify 7 amp fuse (on control board) is okay. | If bin switch light functions, the fuse is okay. (Refer to 7 Amp Fuse Diagnostics, p. 54 .) |
| 4 | Verify the bin switch functions properly. | A defective bin switch can cause a false indication of a full bin of ice. (Refer to Bin Switch Diagnostics, p. 39 .) |
| 5 | Verify Ice/Off/Clean toggle switch functions properly. | A defective toggle switch may keep the ice machine in the OFF mode. (Refer to Toggle Switch Diagnostics, p. 49 .) |
| 6 | Replace control board. | Be sure Steps 1-5 were followed thoroughly. |

II. ICE MACHINE OPERATES BUT WILL NOT CYCLE INTO HARVEST

This ice machine control system incorporates a freeze time "lock-in" feature which protects the ice machine from short cycling in and out of harvest. The control board locks the ice machine in the freeze cycle for 6 minutes. If water contacts the ice thickness probes during the first 6 minutes of the freeze cycle, the harvest light will come on (to indicate water is in contact with the probes), but the ice machine stays in the freeze cycle. After the 6 minutes "lock-in" time is reached, a harvest cycle will be initiated.

To allow the service technician to initiate a harvest without delay, this feature is not used on the first cycle after turning the toggle switch off and then back to the ice making position.

NOTE

These procedures require the use of a jumper wire with clip ends attached.

Step 1. Bypass the freeze time lock-in feature by setting the ICE/OFF/CLEAN toggle switch to off and then back to ice making position.

Wait (approximately 1.5 minutes) until the water starts to flow over the evaporator, then proceed to Step 2.

Step 2. Dual Probe

While monitoring the harvest light, clip the leads of the jumper wire to the ice thickness control probe.

Single Probe

Clip one jumper wire lead to the ice thickness control probe and clip the other lead to a cabinet ground anywhere on the ice machine.

NOTE

When the ice machine cycles into harvest with the water curtain removed, it is normal for the harvest light to turn off and remain off even though the ice machine remains in the harvest cycle. (Original production board only.)

Monitoring of Harvest Light Correction

| | |
|------------------------------------------------------------------------------------------------------|----------------------------------------------------------------------------------------------------------------------------------------------------------------------------|
| a. The harvest light comes on and 6-10 seconds later, the ice machine cycles from freeze to harvest. | The entire control circuitry is functioning properly. Check the following: a. Ice thickness probe adjustment b. Ice thickness probe has scale build-up. Clean probe. |
| b. The harvest light comes on but the ice machine stays in the freeze sequence. | Verify the ice machine is not in "Freeze Time Lock-In", then change control board. |
| c. The harvest light does not come on. | Proceed to Step 3. |

Step 3. Dual Probe

Disconnect the ice thickness probe wires from the control board, terminals 1C and 1D. While monitoring the harvest light, clip the leads of jumper wire to terminals 1C and 1D.

Single Probe

Disconnect the ice thickness probe wire from 1C. While monitoring the harvest light, clip the leads of the jumper wire to terminal 1C and any cabinet ground.

Monitoring of Harvest Light Correction

| | |
|------------------------------------------------------------------------------------------------------|------------------------------------------------------------------------------------|
| a. The harvest light comes on and 6-10 seconds later, the ice machine cycles from freeze to harvest. | Replace ice thickness probe. |
| b. The harvest light comes on but the ice machine stays in the freeze sequence. | Verify the ice machine is not in "Freeze Time Lock-In", then change control board. |
| c. The harvest light does not come on. | Replace the control board. |

III. ICE MACHINE OPERATES BUT CYCLES INTO HARVEST PREMATURELY

This ice machine control system incorporates a freeze time “lock-in” feature which protects the ice machine from short cycling in and out of harvest. The control board locks the ice machine in the freeze cycle for 6 minutes. If water contacts the ice thickness probes during the first 6 minutes of the freeze cycle, the harvest light will come on (to indicate water is in contact with the probes), but the ice machine stays in the freeze cycle. After the 6 minutes “lock-in” time is reached, a harvest cycle will be initiated.

To allow the service technician to initiate a harvest without delay, this feature **is not** used on the first cycle after turning the toggle switch off and then back to the ice making position.

NOTE

It is normal for the harvest light to be flashing as water begins to splash on the ice thickness probe.

Step 1. Dual Probe

Disconnect the ice thickness probe wires from control board terminals 1C and 1D.

Single Probe

Disconnect the ice thickness control probe from terminal 1C.

Step 2. Bypass the freeze time lock-in feature by setting the ICE/OFF/CLEAN toggle switch to off and then back to the ice making position. Wait (approximately 1.5 minutes) until the water starts to flow over the evaporator, then monitor the harvest light.

Monitoring Of Harvest Light Correction

| | |
|-----------------------------------------------------------------------------------------------------------------------|-----------------------------------------------------------------------------------------------------------------------------------------------------------------------------|
| a. The harvest light is staying off and the ice machine remains in the freeze sequence. | The ice thickness probe is causing the malfunction. The ice thickness probe may simply be out of adjustment or dirty. Clean and check adjustment of probe before replacing. |
| b. The harvest light is coming on and 6-10 seconds later the ice machine changes from the freeze to harvest sequence. | Replace the control board. |

B MODEL SINGLE EVAPORATOR SELF-CONTAINED 1 PHASE

CAUTION: DISCONNECT POWER BEFORE WORKING
ON ELECTRICAL CIRCUITRY.

DIAGRAM SHOWN DURING FREEZE CYCLE

SEE SERIAL PLATE FOR VOLTAGE

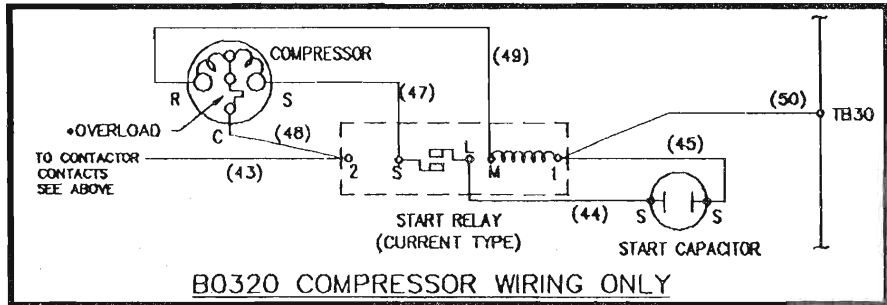
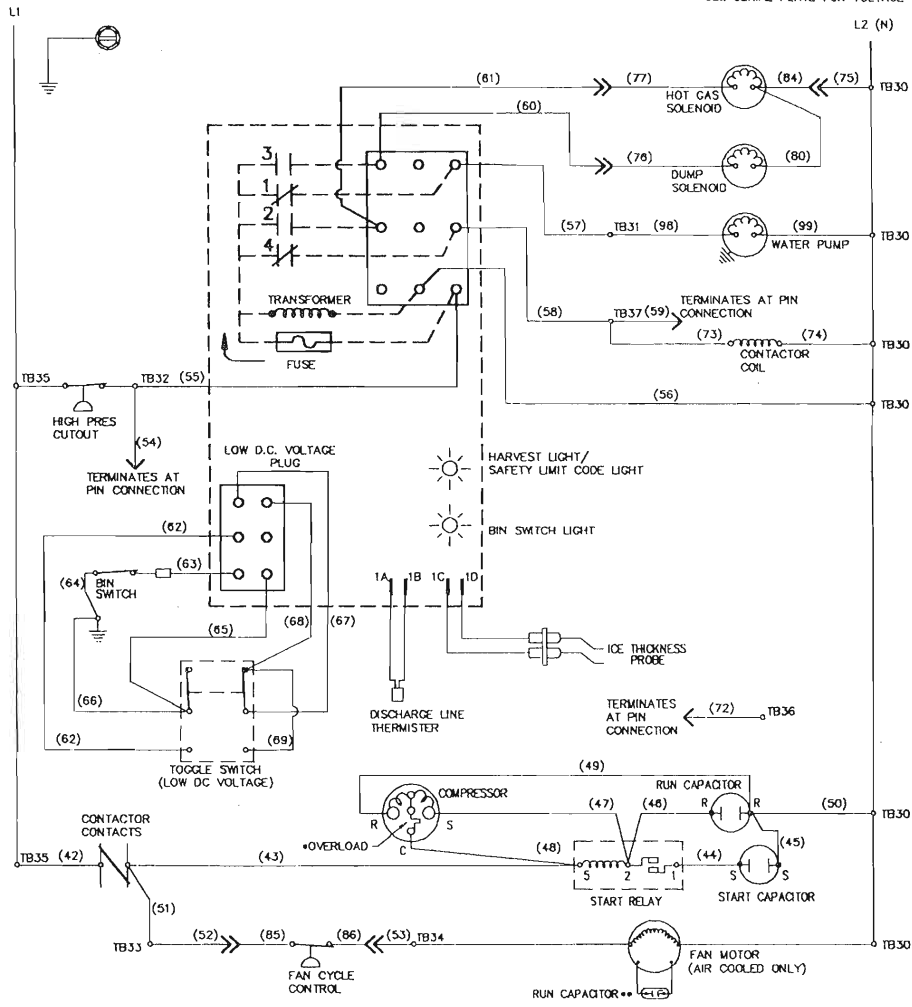

- * - INTERNAL COMPRESSOR OVERLOAD SHOWN. SOME MODELS USE AN EXTERNAL OVERLOAD.
- TB - TERMINAL BOARD CONNECTION
- () - WIRE NUMBER DESIGNATION (# IS MARKED AT EACH END OF WIRE)
- ** - SOME AIR COOLED MODELS MAY NOT HAVE RUN CAPACITOR ON FAN MOTOR
- >>> - BULKHEAD MULTIPIN CONNECTOR
(ELECTRICAL BOX SIDE) >>> (COMPRESSOR COMPARTMENT SIDE)

SV 1222
4/94

B MODEL SINGLE EVAPORATOR SELF-CONTAINED 3 PHASE

CAUTION: DISCONNECT POWER BEFORE WORKING
ON ELECTRICAL CIRCUITRY.

DIAGRAM SHOWN DURING FREEZE CYCLE

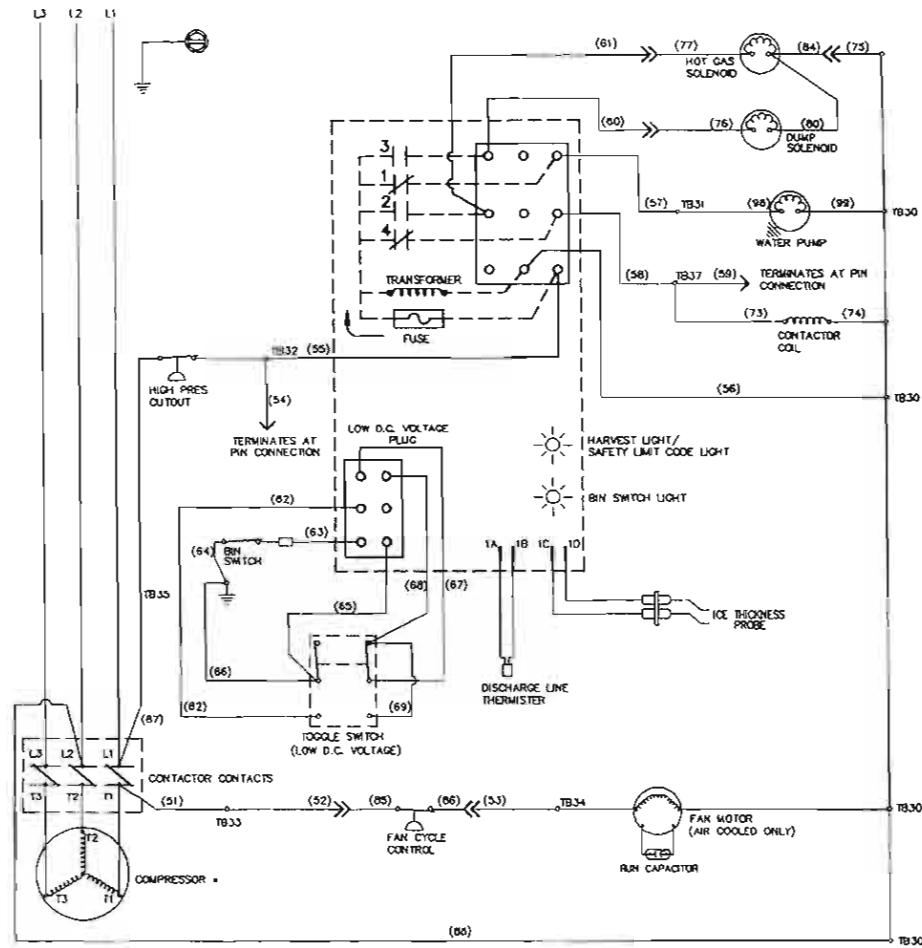

- - COMPRESSOR HAS INTERNAL OVERLOAD
- TB - TERMINAL BOARD CONNECTION
- () - WIRE NUMBER DESIGNATION
(# IS MARKED AT EACH END OF WIRE)
- »» - BULKHEAD MULTIPIN CONNECTOR
(ELECTRICAL BOX SIDE) »» (COMPRESSOR COMPARTMENT SIDE)

SV 1221
4/94

B-MODEL DUAL EVAPORATOR SELF-CONTAINED 1 PHASE

CAUTION: DISCONNECT POWER BEFORE WORKING
ON ELECTRICAL CIRCUITRY.
DIAGRAM SHOWN DURING FREEZE CYCLE

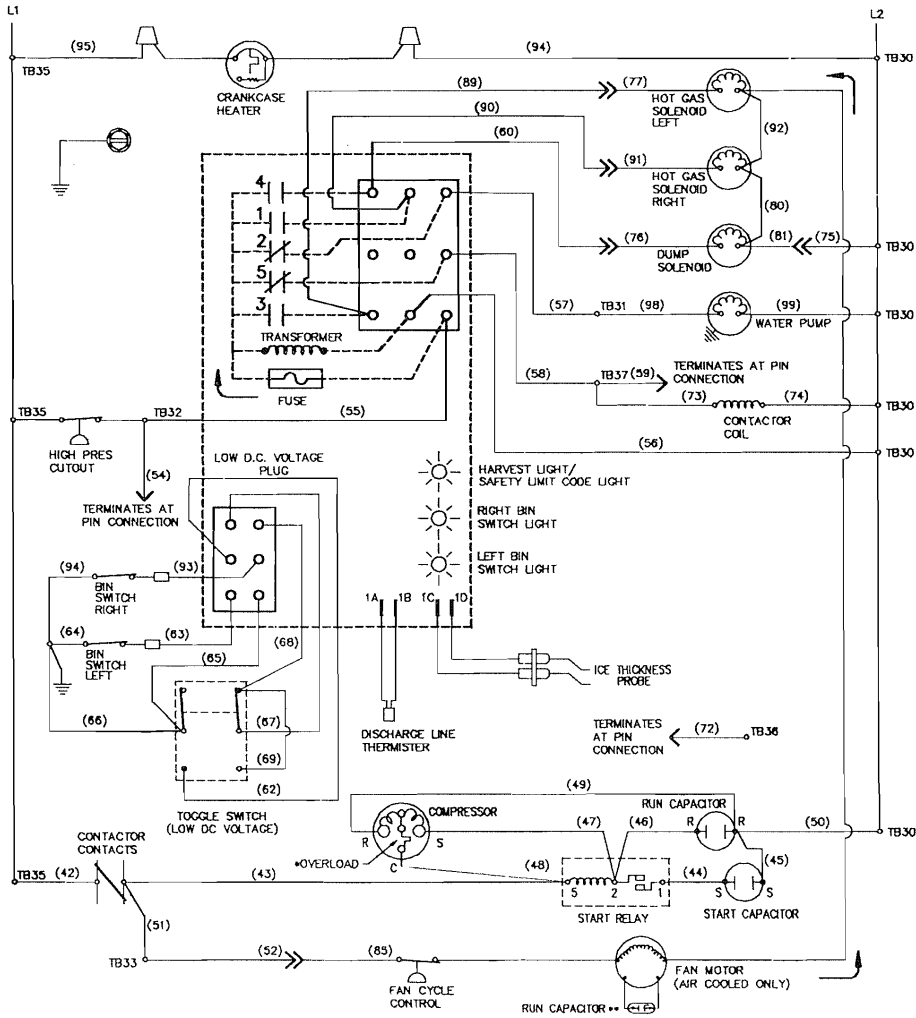

TB - TERMINAL BOARD CONNECTION
 () - WIRE NUMBER DESIGNATION
 (# IS MARKED AT EACH END OF WIRE)
 ** - SOME AIR COOLED MODELS MAY NOT
 HAVE RUN CAPACITOR ON FAN MOTOR
 >>> - BULKHEAD MULTIPIN CONNECTOR
 (ELECTRICAL BOX SIDE) >>> (COMPRESSOR COMPARTMENT SIDE)

SV 1346
4/94

B-MODEL DUAL EVAPORATOR SELF-CONTAINED 3 PHASE

CAUTION: DISCONNECT POWER BEFORE WORKING
ON ELECTRICAL CIRCUITRY.
DIAGRAM SHOWN DURING FREEZE CYCLE

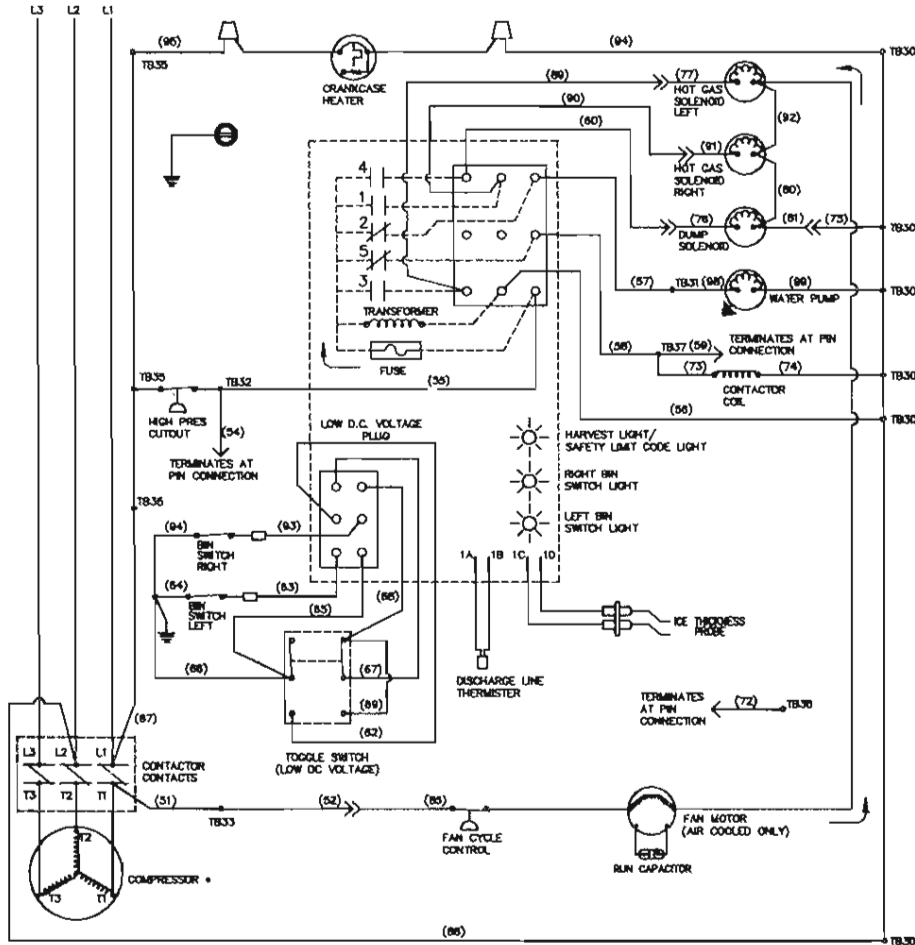

- * - COMPRESSOR HAS INTERNAL OVERLOAD
- TB - TERMINAL BOARD CONNECTION
- () - WIRE NUMBER DESIGNATION
(# IS MARKED AT EACH END OF WIRE)
- - BULKHEAD MULTIPIN CONNECTOR
(ELECTRICAL BOX SIDE) ➤➤ (COMPRESSOR COMPARTMENT SIDE)

SV 1401
4/84

B-MODEL SINGLE EVAPORATOR REMOTE 3 PHASE

CAUTION: DISCONNECT POWER BEFORE WORKING
ON ELECTRICAL CIRCUITRY.
DIAGRAM SHOWN DURING FREEZE CYCLE

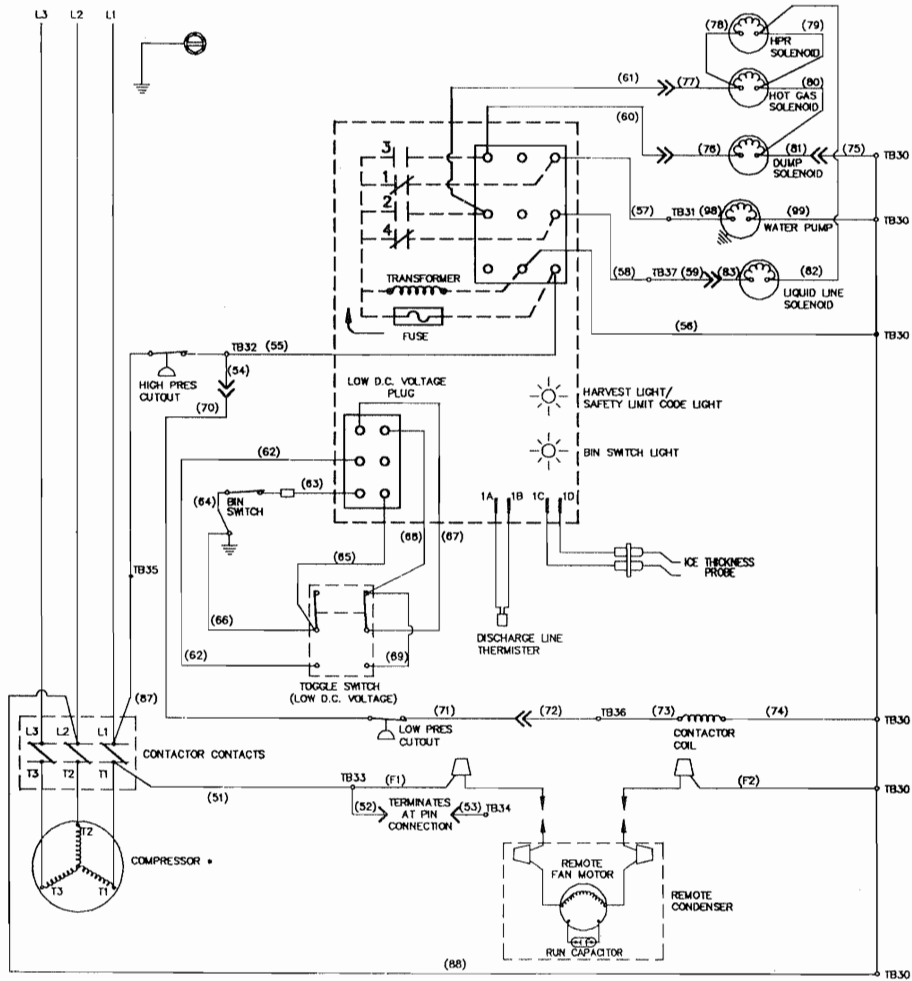

- - COMPRESSOR HAS INTERNAL OVERLOAD
- TB - TERMINAL BOARD CONNECTION
- () - WIRE NUMBER DESIGNATION
(# IS MARKED AT EACH END OF WIRE)
- ⇒ - BULKHEAD MULTIPIN CONNECTOR
(ELECTRICAL BOX SIDE) ⇒ (COMPRESSOR COMPARTMENT SIDE)

SV 1220
4/94

B-MODEL DUAL EVAPORATOR REMOTE 1 PHASE

CAUTION: DISCONNECT POWER BEFORE WORKING
ON ELECTRICAL CIRCUITRY.

DIAGRAM SHOWN DURING FREEZE CYCLE

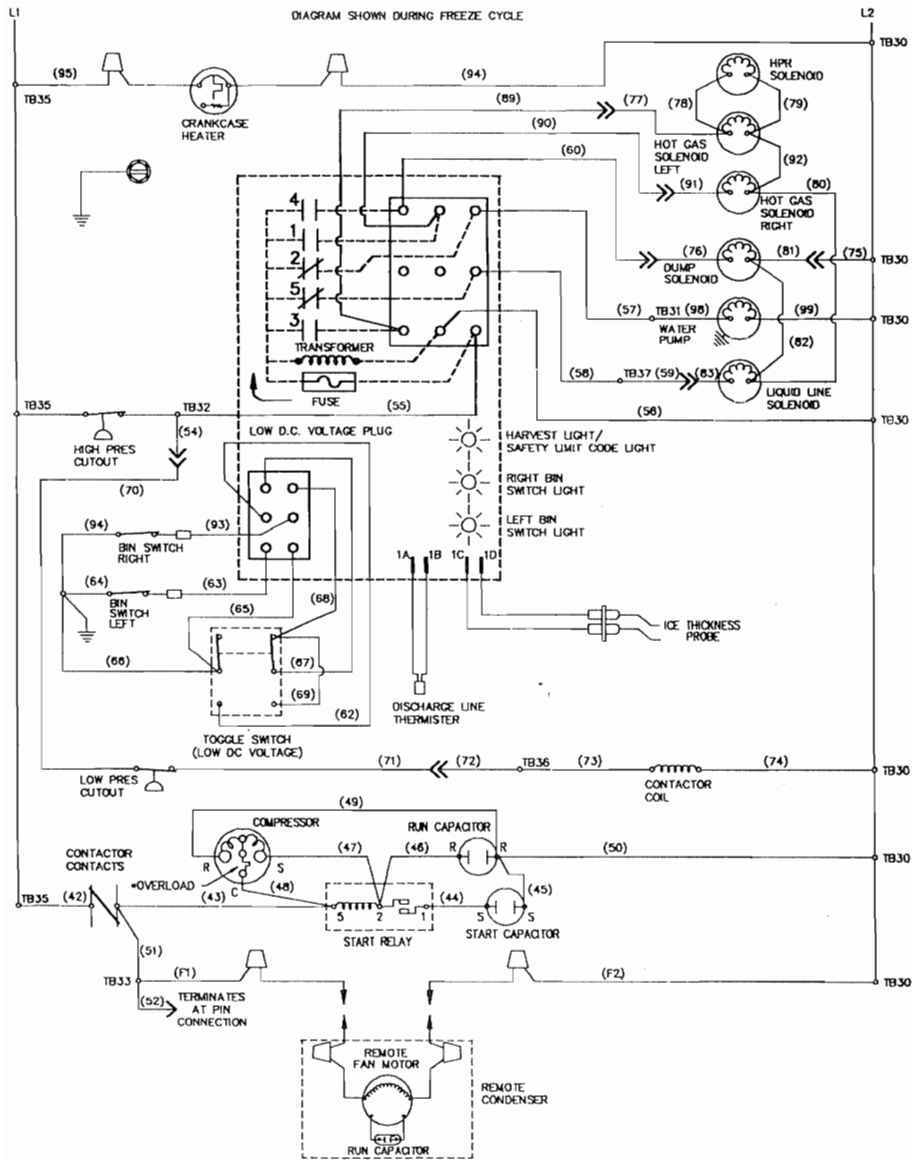

- - COMPRESSOR HAS INTERNAL OVERLOAD
- TB - TERMINAL BOARD CONNECTION
- () - WIRE NUMBER DESIGNATION
(# IS MARKED AT EACH END OF WIRE)
- - BULKHEAD MULTIPIN CONNECTOR
(ELECTRICAL BOX SIDE) ➤ (COMPRESSOR COMPARTMENT SIDE)

SV 1347
4/94

B-MODEL DUAL EVAPORATOR REMOTE 3 PHASE

CAUTION: DISCONNECT POWER BEFORE WORKING
ON ELECTRICAL CIRCUITRY.
DIAGRAM SHOWN DURING FREEZE CYCLE

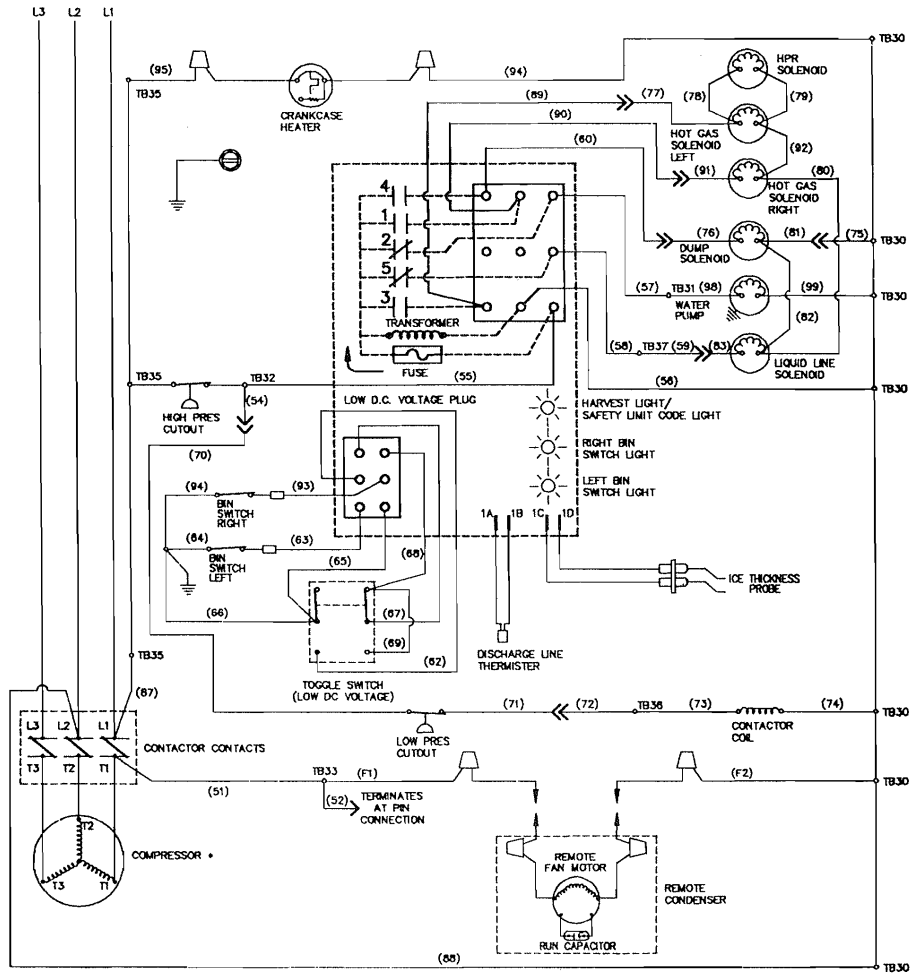

- * - COMPRESSOR HAS INTERNAL OVERLOAD
- TB - TERMINAL BOARD CONNECTION
- () - WIRE NUMBER DESIGNATION
(# IS MARKED AT EACH END OF WIRE)
- - BULKHEAD MULTIPIN CONNECTOR
(ELECTRICAL BOX SIDE) ➤➤ (COMPRESSOR COMPARTMENT SIDE)

SV 1402
4/94

B-MODEL DUAL EVAPORATOR REMOTE 380/415V/50 HZ/3 PH

CAUTION: DISCONNECT POWER BEFORE WORKING
ON ELECTRICAL CIRCUITRY.
DIAGRAM SHOWN DURING FREEZE CYCLE

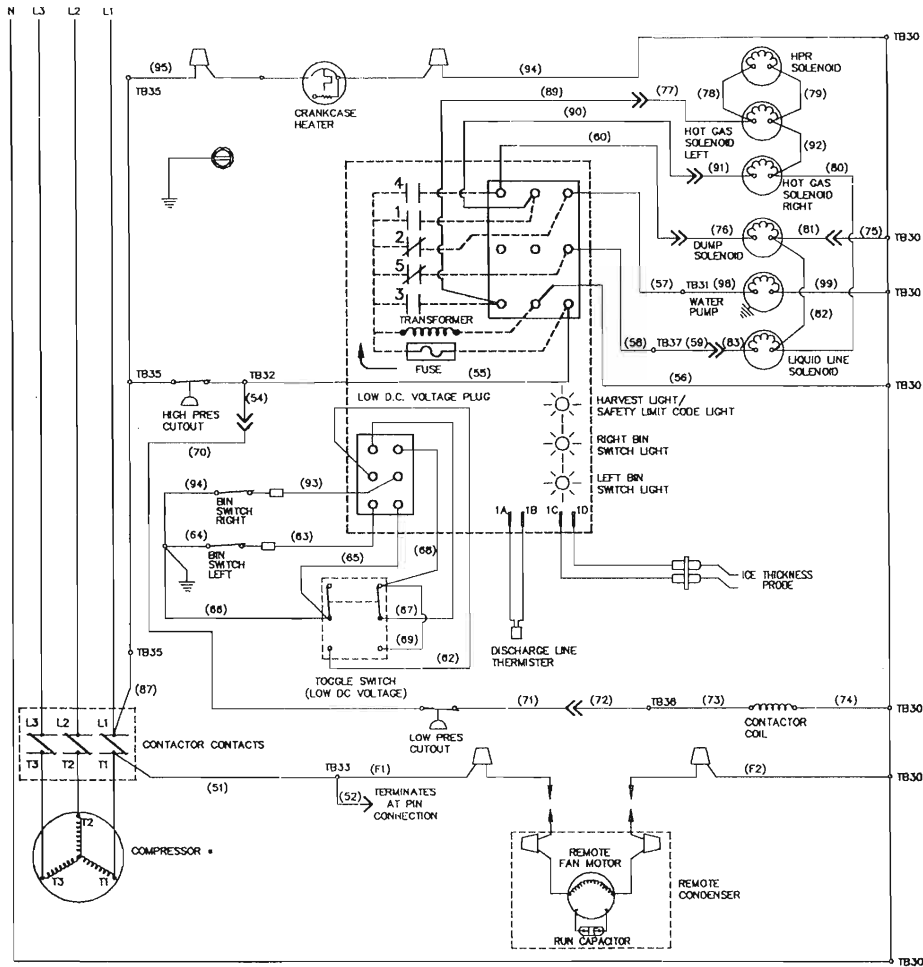

- * - COMPRESSOR HAS INTERNAL OVERLOAD
- TB - TERMINAL BOARD CONNECTION
- () - WIRE NUMBER DESIGNATION
(# IS MARKED AT EACH END OF WIRE)
- - BULKHEAD MULTIPIN CONNECTOR
(ELECTRICAL BOX SIDE) ➤ (COMPRESSOR COMPARTMENT SIDE)

SV 1403
4/94

HARVEST PRESSURE REGULATING (H.P.R.) SYSTEM

Remote Ice Machines

GENERAL

The harvest pressure regulating (H.P.R.) system includes:

- 1 **Harvest pressure regulating solenoid valve** (H.P.R. solenoid)

This is an electrically operated valve which opens when energized and closes when de-energized.

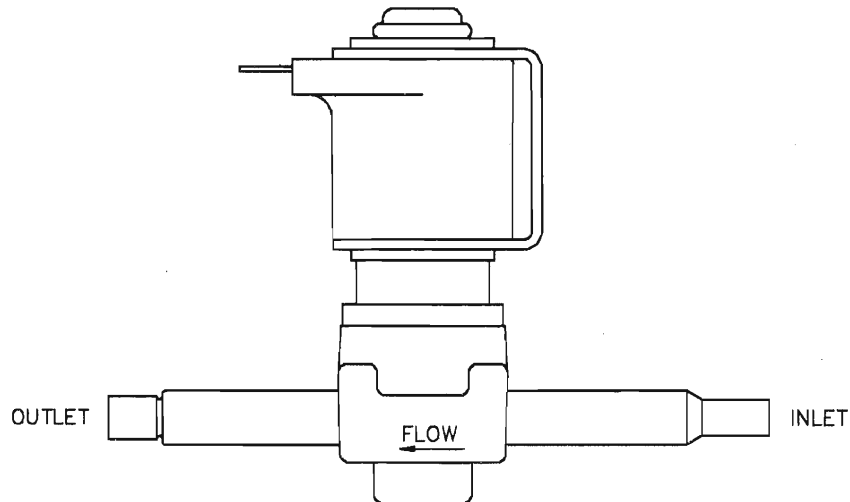

- 2 **Harvest pressure regulating valve** (H.P.R. valve)

This is a non-adjustable pressure regulating valve which modulates open and closed, based on the refrigerant pressure at the outlet of the valve. The valve closes completely and stops refrigerant flow when the pressure at the outlet raises above the setting of the valve.

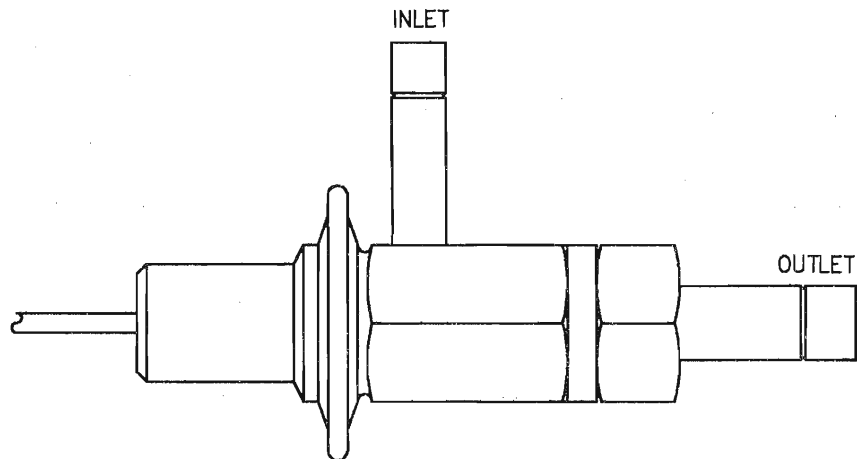

NORMAL OPERATION

Freeze Cycle

The H.P.R. system is not used during the freeze cycle. The H.P.R. solenoid is closed (de-energized) preventing refrigerant flow into the H.P.R. valve.

Harvest Cycle

The check valve in the discharge line prevents refrigerant in the remote condenser and receiver from back-feeding into the evaporator(s) and condensing to liquid during the harvest cycle. The H.P.R. solenoid is opened (energized) during the harvest cycle allowing refrigerant gas from the top of the receiver to flow into the H.P.R. valve. The H.P.R. valve modulates opened and closed raising the suction pressure high enough to sustain heat for the harvest cycle without refrigerant condensing to liquid in the evaporator(s).

In general, the harvest cycle suction pressure raises, then stabilizes somewhere in the range of 75-100 psig (517-758 Kpa).

The stabilized pressures, which vary from model to model, are found by referring to appropriate "Operational Refrigeration Pressure" chart.

H.P.R. SYSTEM FAILURE CHART

| SYMPTOMS | | POSSIBLE CAUSE |
|---------------|-----------------------------------------------------------------------------------------------------------------------------------------------------------------------------------------------------------------------------------------------------------------------------------------------------------------------------------------------------------------------------------------------------------------------------------------------------------------------------------------------------------------------------------------------------------|---------------------------------------------------------------------------------|
| Freeze cycle | The ice machine functions properly (the H.P.R. solenoid is closed preventing refrigerant flow into the H.P.R. valve). | H.P.R. Solenoid remains closed - OR - H.P.R. Valve remains closed |
| Harvest cycle | The discharge pressure is low or normal and the suction pressure is low which causes extended harvest times. | |
| Notes | <p>The ice machine usually continues to run, although with the extended harvest times, the ice production decreases.</p> <p>If harvest time exceeds 3.5 minutes for three consecutive cycles, the control board stops the entire ice machine operation on Safety Limit #2.</p> <p>Low discharge pressure during the freeze cycle causes H.P.R. valve to appear as though it is not feeding properly during harvest. Verify discharge pressure during the freeze is normal (correct if necessary) prior to assuming the H.P.R. valve is faulty.</p> | |

(continued on next page)

H.P.R. SYSTEM FAILURE CHART

(continued from previous page)

| | SYMPTOMS | POSSIBLE CAUSE |
|---------------|------------------------------------------------------------------------------------------------------------------------------------------------------------------------------------------------------------------------------------------------------------------------------------------------------------------------------------------------------------------------------------------------------------------------------------------------------------------------------------------------------------|---------------------------------------|
| Freeze cycle | The discharge pressure is normal and the suction pressure is high. Frost forms on the compressor outward from where the H.P.R. system enters the compressor. (Not the large return suction line from evaporators.) | H.P.R. Solenoid leaks or remains open |
| Harvest cycle | The discharge pressure is slightly low or normal and the suction pressure slightly low or normal. Although the frost usually disappears during the harvest cycle, the compressor remains cold, which causes extremely long harvest cycles. | |
| Notes | <p>The compressor discharge gas during harvest usually drops below 85°F (29.4°C). After three consecutive cycles of this, the control board stops the ice machine on Safety Limit #3. The control board de-energizes the liquid line solenoid, although with the H.P.R. solenoid internally stuck open, the compressor cannot "pump down" and shut off.</p> <p>As the compressor runs without the liquid line solenoid or other components energized, it heats up and cycles off on internal overload.</p> | |

FILTER-DRIERS

The filter-driers used on Manitowoc ice machines are filter-driers manufactured to our specifications.

The difference between Manitowoc driers and off-the-shelf type driers is in filtration. Manitowoc's have dirt retaining filtration with fiberglass filters on both the inlet and outlet ends. This is very important because ice machines have a back-flushing action which takes place every harvest cycle. These filter-driers have very high moisture removal capability and good acid removal capacity.

The size of the filter-drier is important. The refrigerant charge is critical and use of an oversized or undersized drier will cause the ice machine to be improperly charged.

Listed below are the recommended O.E.M. field replacement driers:

| <u>Machine Size</u> | <u>Drier Size</u> | <u>End Connection Size</u> | <u>Part No.</u> |
|-------------------------|-----------------------|------------------------------------|-----------------|
| B150, B250 | "032" | 1/4" | 12-3005-1 |
| B200, B320 | "032" | 1/4" | 12-3005-1 |
| B420, B450 | "032" | 1/4" | 12-3005-1 |
| B600 | "032" | 1/4" | 12-3005-1 |
| B800, B1000 | "082" | 1/4" | 89-3010-3 |
| B1300, B1800 | "083" | 3/8" | 89-3015-3 |

DRIERS ARE COVERED AS A WARRANTY PART AND ARE TO BE REPLACED ANY TIME THE SYSTEM IS OPENED FOR REPAIRS.

HEADMASTER CONTROL VALVE (Remote Machines)

Manitowoc remote systems require headmaster control valves with special settings. Replace defective headmaster control valves **only** with "original" Manitowoc replacement parts.

Operation

The HP81 headmaster control valve has a non-adjustable setting of 225 psig. At ambient temperatures of approximately 70°F (21.1°C) or above, refrigerant flows through the valve from the condenser to the receiver inlet. At temperatures below approximately 70°F (21.1°C), the head pressure control dome's nitrogen charge closes the condenser port and opens the bypass port from the compressor discharge line. In this modulating mode, the valve maintains minimum head pressure by building up liquid in the condenser and bypassing discharge gas directly to the receiver.

Diagnosing Headmaster Valve

1. Determine air temperature entering remote condenser.
2. Determine if head pressure is high or low in relationship to outside temperature (refer to an Operation Pressure Chart for the model of ice machine on which you are working). If air temperature is below approximately 70°F (21.1°C), the head pressure should be modulating around 225 psig.
3. Determine the temperature of the liquid line entering the receiver by feeling with hand. This line is normally "body temperature" (warm).
4. Using the symptoms gathered in Steps 2 and 3, refer to Failure Chart on page 85.

NOTE

An ice machine with a failed headmaster that will not bypass will function properly with condenser air temperatures of approximately 70°F (21.1°C) or above. When temperature drops below approximately 70°F (21.1°C), the headmaster fails to bypass and the ice machine malfunctions.

Low On Charge Verification

The remote ice machine requires more refrigerant charge at lower ambient temperatures than at higher temperatures. A low on charge ice machine may function properly during the day (higher condenser air temperature) and then malfunction during the night (when the temperature drops).

Following this procedure, if after using the Headmaster Control Valve failure chart, it is still not verified that the ice machine is low on charge,:

1. Add refrigerant in 2 lb. increments, but do not exceed 6 lbs.
2. If the ice machine was low on charge, the headmaster function and discharge pressure will return to normal after the charge is added. Do not leave the ice machine run. To assure operation in all ambient conditions, the refrigerant leak must be found and repaired, the liquid line drier changed, and the ice machine evacuated and recharged with proper nameplate charge.
3. If the ice machine does not start to operate properly after adding charge, replace the headmaster.

HEADMASTER CONTROL VALVE FAILURE CHART

| Possible Problem | Probable Cause | Corrective Measure |
|------------------------------------------------------------------------------------|---------------------------|----------------------------------------------------------------|
| Valve not maintaining pressures | Non-approved valve | Install Manitowoc Headmaster Control Valve with proper setting |
| a. Discharge pressure extremely high b. Liquid line entering receiver feels hot | Valve stuck in bypass | Replace valve |
| a. Discharge pressure low b. Liquid line entering receiver extremely cold | Valve not bypassing | Replace valve |
| a. Discharge pressure low b. Liquid line entering receiver is warm-to-hot | Ice machine low on charge | Refer to "Low on charge verification" listed on page 84 |

FAN CYCLE CONTROL **(Self-Contained Air-Cooled Models)**

Function

Cycles fan motor on and off to maintain proper operating discharge pressure.

The fan cycle control is normally closed and opens on a drop in discharge pressure.

Specifications

Cut-out — 200 P.S.I.G. (+/-5)

Cut-in — 250 P.S.I.G.

Check Procedure

1. Verify fan motor windings are not open or grounded and fan spins freely.
2. Connect manifold gauges to ice machine.
3. Hook voltmeter in parallel (across) to the fan cycle control, leaving wires attached.
4. Pressure above listed specification — read 0 volts and fan should be running.

Pressure below listed specification — read line voltage and fan should be off.

LOW PRESSURE CUT-OUT CONTROL (Remote Machines)

Function

The low pressure control opens and closes by suction pressure to energize and de-energize the contactor which starts and stops the compressor and remote fan motor.

A drop in suction pressure opens the low pressure cut-out control.

Specifications

Cut-out — 12 P.S.I.G. (± 3)

Cut-in — 35 P.S.I.G. (± 5)

NOTE: Early Production models may have setting of 5 P.S.I.G. cut-out and 40 P.S.I.G. cut-in. All replacement controls have new setting of 12 P.S.I.G. cut-out and 35 P.S.I.G. cut-in.

Check Procedure

1. Connect manifold gauges.
2. Connect a voltmeter in parallel (across) to the L.P. control leaving wires attached.
3. Set toggle switch to OFF position.
4. The liquid line solenoid valve will de-energize and the suction pressure will begin to decrease. The low pressure cut-out control will open at listed specification. The voltage across the L.P. cut-out control will be "line voltage".
5. Set toggle switch to ICE position. The liquid line solenoid valve will energize and the suction pressure will rise. The low pressure cut-out control will close at listed specification and the compressor and remote fan motor will start.

Voltage across the low pressure cut-out must be "0" volts with the compressor running.

6. Replace the low pressure cut-out control when not opening and closing properly or does not maintain proper settings.

HIGH PRESSURE CUT-OUT CONTROL — H.P.C.O.

Function

Safety control which stops the ice machine if subjected to excessive high-side pressure. The H.P.C.O. control is a normally closed control and opens on a rise in pressure.

Specifications

Cut-out — 440 P.S.I.G. \pm 10.

Cut-in — manual reset

(below 300 P.S.I.G. to reset).

Check Procedure

1. Set ICE/OFF/CLEAN switch at OFF and reset H.P.C.O. (if tripped).
2. Connect manifold gauges.
3. Hook voltmeter in parallel (across) to the H.P.C.O. leaving wires attached.
4. a. Water-Cooled Models — Close the water service valve to the water condenser inlet.
b. Self-Contained Air-Cooled and Remote Models — Disconnect fan motor.
5. Set ICE/OFF/CLEAN switch to ICE.

No water or air flowing through the condenser will cause the H.P.C.O. control to turn the ice machine off because of excessive high pressure. Watch the high-pressure gauge and record the pressure at which the cut-out takes place.

CAUTION

Stop ice machine operation by turning the toggle switch off if discharge pressure is exceeding 440 psig and H.P.C.O. did not open to stop the ice machine.

Replace the H.P.C.O. control if:

1. The control will not reset.

NOTE

High-side pressure must be below listed specifications before resetting.

2. The control does not open at the specified cut-out point.

REFRIGERATION SYSTEM OPERATIONAL ANALYSIS

GENERAL

When analyzing the refrigeration system, it is important to understand that different refrigeration component malfunctions may cause very similar symptoms. Also, external factors such as improper installation, incoming water supply being too hot, and water system malfunctions can often cause good refrigeration components to appear to be defective.

The following two examples illustrate how similar symptoms can result in a mis-diagnosis and the replacement of good components in error:

Example 1 An expansion valve bulb that is not securely fastened to the suction line and/or not insulated will cause a good expansion valve to flood. A service technician fails to check for proper expansion valve bulb mounting and replaces the expansion valve in error.

The ice machine now functions properly and the service technician erroneously thinks that the problem was properly diagnosed and corrected by replacing the expansion valve. In reality, the problem (loose bulb) was corrected when the service technician properly remounted the bulb of the replacement expansion valve.

In this example, the service technician's failure to check the expansion valve bulb for proper mounting (an external check) resulted in a misdiagnosis and the needless replacement of a good expansion valve.

Example 2 An ice machine that is low on charge may cause a good expansion valve to starve. A service technician fails to verify system charge and replaces the expansion valve in error. During the expansion valve replacement procedure, recovery; evacuation; and recharging are performed correctly and the ice machine now functions normally. The service technician mistakenly believes that the problem has been diagnosed correctly and that by replacing the expansion valve, he restored the ice machine to normal operation.

In this second example, the service technician's failure to check the ice machine for a low charge condition also resulted in the needless replacement of a good expansion valve.

REFRIGERATION SYSTEM OPERATIONAL ANALYSIS TABLES

When analyzing the refrigeration system, one can avoid replacing good refrigeration components caused by "external problems" by using a Refrigeration System Operational Analysis Table with the use of detailed checklists and references.

A list of some of the detailed charts/checklists and other references used with either the Single or Dual Evaporator Refrigeration System Operational Analysis Table includes:

- Before beginning service (Questions to ask end user)
- Installation/Visual Inspection Checklist
- Water System Checklist
- How to perform Ice Production Check
- Analyzing ice formation
- Understanding and analyzing Safety Limits
- Analyzing hot gas valves
- Comparing evaporator inlet to outlet temperatures (single evaporator ice machines)
- Comparing left evaporator inlet to right evaporator inlet temperatures (dual evaporator ice machines)
- Understanding and analyzing discharge pressure
- Understanding and analyzing suction pressure

BEFORE BEGINNING SERVICE

It is common for ice machines to experience operational problems only during certain times of the day or night. The ice machine may be functioning properly while servicing it, but malfunctions later. The information the user provides helps the service technician start in the right direction and may be a determining factor in the final diagnosis.

Following are a few questions to consider when talking to the ice machine user:

- When is the ice machine malfunctioning? (Night, day, all the time, during the freeze cycle, harvest cycle, etc.)
- When do you notice low production? (One day a week, every day, weekends, etc.)
- Can you describe exactly what the ice machine seems to be doing?
- Has anyone been working on the ice machine?
- Were items (such as boxes obstructing air flow) moved from around the ice machine before you arrived?
- During "store shutdown", is the circuit breaker, water supply, or air temperature altered?
- Can you think of any reason that might cause water pressure to rise or drop substantially?

INSTALLATION/VISUAL INSPECTION CHECKLIST

| Possible Problem | Corrective Action |
|--------------------------------------------------------------------------|------------------------------------------------------------------|
| 1. Ice machine not level. | Level ice machine. |
| 2. Improper air clearance around top, sides, and/or back of ice machine. | Reinstall in accordance with Installation Manual. |
| 3. Air-cooled condenser filter dirty. | Clean condenser and/or condenser filter. |
| 4. Ice machine not on independent electrical circuit. | Install electrical in accordance with Installation Manual. |
| 5. Water filtration plugged (if used). | Install new water filter. |
| 6. Water drains not run separately and/or not vented. | Run drains separately and vent according to Installation Manual. |
| 7. Remote condenser line set improperly installed. | Refer to Installation Instructions. |

WATER SYSTEM CHECKLIST

Water related problems in ice machines often cause the same symptoms as a refrigeration system component malfunction.

Water area problems must be identified and eliminated prior to replacing refrigeration components. An example is a water dump valve leaking during the freeze cycle, low on charge, or starving TXV. The symptoms of all 3 of these problems are similar.

| Possible Problem | Corrective Action |
|-----------------------------------------------------------------------------------------------|-----------------------------------------------------------------------|
| 1. Water area (evaporator) dirty. | Clean. |
| 2. Water inlet pressure must be between 20-80 psi. | Install water regulator valve or increase water pressure. |
| 3. Incoming water supply temperature must be 35°F (1.7 °C) to 90°F (32.2°C). | Too hot - check hot water line check valves in other store equipment. |
| 4. Water filter restricted (if used). | Replace filter. |
| 5. Water dump valve leaking during the freeze cycle. | Clean dump valve. Replace as needed. |
| 6. Vent tube not installed on water outlet drain. | See Installation Instructions. |
| 7. Hoses, fittings, etc. leaking water. | Repair/replace as needed. |
| 8. Water float valve stuck open or out of adjustment. | Readjust or replace as needed. |
| 9. Water spraying out of sump trough area. | Stop water spray. |
| 10. Water flow uneven across evaporator. | Clean ice machine. |
| 11. Water freezing behind evaporator. | Correct water flow. |
| 12. Plastic extrusions and gasket material not securely mounted to evaporator. | Remount or replace as needed. |
| 13. Water flow must start over evaporator (not trickle) immediately after 30 second prechill. | Readjust or replace float valve. |

ICE PRODUCTION CHECK

The amount of ice a machine produces has a direct relationship to the operating water and air temperatures. This means an ice machine produces more ice in a 70°F (21.2°C) room with 50°F (10.0°C) water than in a 90°F (32.2°C) room with 70°F (21.1°C) water.

STEP 1 DETERMINE THE ICE MACHINE OPERATING CONDITIONS

Air temperature entering condenser _____

Air temperature around ice machine _____

Water temperature entering float valve _____

STEP 2 REFER TO A 24 HOUR PRODUCTION CHART FOR THE ICE MACHINE MODEL BEING TESTED

Using the operating conditions determined in Step 1, find the published 24 hour ice production:

This is the approximate amount of ice the ice machine is capable of producing at these operating conditions.

STEP 3 PERFORM AN ACTUAL ICE PRODUCTION CHECK

| | | | | | |
|----|------------------------|---|------------------|---|---------------------------------|
| 1. | _____ | + | _____ | = | _____ |
| | Freeze time | | Harvest time | | Total Cycle Time |
| 2. | 1440 | ÷ | _____ | = | _____ |
| | Minutes in 24 hrs. | | Total cycle time | | Cycles per day |
| 3. | _____ | x | _____ | = | _____ |
| | Weight of 1 harvest | | Cycles/day | | Actual 24 hr. ice production |

IMPORTANT NOTES

- Times are in minutes.
Example: 1 min. 15 sec. converts to 1.25 min.
(15 sec. ÷ 60 sec. = .25 min.)
- Weights are in pounds.
Example: 2 lb. 6 oz. converts to 2.375 lb.
(6 oz. ÷ 16 oz. = .375 lb.)

Weighing the ice is the only 100% accurate check. Although, if ice pattern is normal and 1/8" thickness is maintained, the ice slab weights listed with the published 24 hr. ice production charts may be used.

STEP 4 COMPARE THE ACTUAL 24 HR. ICE PRODUCTION FINDINGS WITH THE PUBLISHED 24 HR. ICE PRODUCTION CHART

The ice production is normal when the published 24 hr. ice production (Step 2) and actual (Step 3) match closely. Determine if another ice machine is needed, more storage capacity is required, or if relocating existing equipment to lower load conditions will meet the customer's needs. (Contact local Manitowoc Distributor for options and accessories available.)

ICE FORMATION PATTERN

Evaporator ice formation pattern analysis is helpful in ice machine diagnostics, however, an improper ice formation can be caused by any number of problems. Because of this, **never attempt** to analyze only the ice formation pattern in an attempt to determine what is wrong with an ice machine. A good example of this is an ice formation of "extremely thin on top". This could be caused by hot water supply, dump valve leaking water, faulty float valve, low on refrigerant charge, etc.

IMPORTANT

The water curtain must be in place to ensure no water is being lost while checking ice pattern.

DETERMINING ICE FORMATION PATTERN

1. **NORMAL ICE FORMATION** - There is ice forming on the entire evaporator surface.

At the beginning of the freeze cycle, it may appear that there is more ice forming on the bottom of the evaporator than on the top. However, by the end of the freeze cycle, the ice formation on the top will "catch up" and be close to, or just slightly thinner than, the ice formation on the bottom. This is normal and the "dimples" in the ice cubes on the top of the evaporator will be more pronounced than those on the bottom of the evaporator.

The ice thickness probe must be properly set to maintain the ice bridge thickness at approximately 1/8". Ice forming uniformly on the entire evaporator surface, although not reaching the 1/8" setting in the proper amount of time, is considered "normal ice formation".

2. **EXTREMELY THIN ON TOP** - There is no ice, or considerably less ice formation on the top of evaporator compared to the bottom

Examples:

- a. No ice at all at the top of evaporator, but ice forms on the bottom half of evaporator.
- b. The ice on the top of the evaporator reaches the 1/8" setting to initiate a harvest, but the bottom of the evaporator already has 1/2"-1" of ice formation.

3. **EXTREMELY THIN ON BOTTOM** - There is no ice, or considerably less ice formation on the bottom of the evaporator compared to the top.

Example: The ice on the top of the evaporator reaches the 1/8" setting to initiate a harvest, but there is no ice formation at all on the bottom of the evaporator.

4. **"SPOTTY" ICE PATTERN** - There are small sections of no ice formation such as a single corner or single spot in the middle of the evaporator. This is generally caused by loss of heat transfer from tubing on backside of evaporator.
5. **NO ICE FORMATION** - The ice machine operates for an extended period, but there is no ice formation at all on the evaporator.

SAFETY LIMITS

GENERAL

In addition to standard safety controls such as high pressure cut-out, the control board has four built-in safety limit controls which protect the ice machine from major component failures.

Safety Limit #1: If the freeze time reaches 60 minutes, the control board automatically initiates a harvest cycle. If three consecutive 60 minute freeze cycles occur, the ice machine stops.

Safety Limit #2: If the harvest time reaches 3.5 minutes, the control board automatically returns the ice machine to the freeze cycle. If three consecutive 3.5 minute harvest cycles occur, the ice machine stops.

Safety Limit #3: If the compressor discharge line temperature falls below 85°F/29.4°C for three consecutive harvest cycles, the ice machine stops.

Safety Limit #4: If the compressor discharge line temperature reaches 255°F/123.8°C for 15 continuous seconds during a freeze or harvest cycle, the ice machine stops.

DETERMINING WHICH SAFETY LIMIT STOPPED THE ICE MACHINE

When a safety limit condition causes the ice machine to stop, the harvest light on the control board continually flashes on and off. Use the following procedures to determine which safety limit has stopped the ice machine.

- Step 1 Move the toggle switch to off.
- Step 2 Move the toggle switch back to ice making position.
- Step 3 Watch the harvest light. It will "flash on" one to four times, corresponding to safety limits 1-4, to indicate which safety limit stopped the ice machine.

After safety limit indication, the ice machine will re-start and run until a safety limit is exceeded again.

NOTES

- A continuous run of 100 harvests automatically erases the safety limit code.
- The control board will store and indicate only one safety limit - the last one exceeded.
- Any time the toggle switch is moved to the "off" position and then back to the "on" position again prior to reaching the 100 harvest point, the last safety limit exceeded will be indicated.
- The ice machine did not stop on a safety limit if the harvest light did not "flash on" prior to ice machine restarting.

ANALYZING WHY SAFETY LIMITS STOPPED ICE MACHINE

According to the refrigeration industry, a high percentage of compressors fail as a result of external causes such as flooding or starving expansion valves, overcharge, undercharge, dirty condensers, water loss to ice machine, etc. The safety limits protect the ice machine (primarily the compressor) from external failures by stopping ice machine operation before major component damage occurs.

The safety limit system is similar to a high pressure cut-out control. It stops the ice machine, but does not tell what is wrong. The service technician must analyze the system to determine what caused the ice machine to stop on the high pressure cut-out, or a particular safety limit.

The safety limits are designed to stop the ice machine prior to major component failures, most often non-major problems or something external to the ice machine that may be causing the problem. This may be difficult to diagnose, as many external problems may occur intermittently. (An example of this would be an ice machine stopping intermittently on safety limit #3 - low discharge temperature. The service technician may find that at night the ambient temperature is dropping too low, the store has a water pressure drop problem, or the water is being turned off one night a week, etc.) It is always good to remember that when a high pressure cut out or a safety limit stops the ice machine, they are doing what they are supposed to do stop the ice machine before a major component failure occurs.

Ice machine refrigeration and electrical component failures may also cause the ice machine to stop on one of the safety limits. After all electrical component and all external causes are eliminated and it is thought the refrigeration system is causing the problem, use Manitowoc's Refrigeration System Operational Analysis Table, along with detailed charts, checklists, and other references, to determine the cause.

The following checklists are designed to assist the service technician in analysis. Because many external problems are possible, do not limit yourself only to the items listed in the checklists.

| CONDITION FOUND | POSSIBLE CAUSE |
|----------------------------------------------------------------------------------------------------------------------------------|-----------------------------------------------------------------------------------------------------------------------------------------------------------------------------------------------------------------------------------------------------------------------------------------------------------------------------------------------------------------------------------------------------------------------------------------------------------------------------------------------------------------------------------------------------------------------------------------------------------------------------------------------------------------------------------------------------------------------------------------------------------------------------------------------------------------------------------------------------------------------------------------------------------------------------------------------------------------------------------------------------------------------------------------------------------------------------------------------------------------------------------------------------------------------------------------------------------------------------------------------------------------------------------------------------------------------------------------------------------------------------------------------------------------------------------------------------------------------------------------------------------------------------------------------------------------------------------------------------------------------------------------------------------------------------------------------------------------------------------------------------------------------------------------------------------------------------------------------------------------------------------------------------------|
| <p>I. SAFETY LIMIT #1 stopped the ice machine. (Freeze time exceeded 60 minutes for three consecutive freeze cycles.)</p> | <ol style="list-style-type: none"> 1. Improper installation <ul style="list-style-type: none"> • Refer to Installation/Visual Inspection Checklist 2. Water system <ul style="list-style-type: none"> • Incoming water pressure low • Excessive water pressure (80 psi maximum) • Excessive water temperature (90°F/32.2°C maximum) • Dirty (clogged) water distribution tube • Dirty/defective float valve • Dirty/defective water dump valve • Defective water pump 3. Electrical system <ul style="list-style-type: none"> • Ice thickness probe out of adjustment • Electrically not going into harvest • Contactor not energizing • Compressor (electrically non-operational) 4. Restricted condenser air flow (air-cooled models) <ul style="list-style-type: none"> • Inlet air temperature excessive • Condenser discharge air recirculation • Dirty condenser filter • Dirty condenser fins • Defective fan cycling control • Defective fan motor 5. Restricted condenser water flow (water-cooled models) <ul style="list-style-type: none"> • Insufficient water pressure (20 psi minimum) • Excessive water temperature (90°F/32.2°C maximum) • Dirty condenser and/or water regulating valve • Water regulating valve out of adjustment • Defective water regulating valve 6. Refrigeration system <ul style="list-style-type: none"> • Non-Manitowoc components • Under or over refrigerant charge • Defective head pressure control (remotes) • Defective hot gas valve • TXV starving or flooding (check bulb mounting) |

| CONDITION FOUND | POSSIBLE CAUSE |
|--------------------------------------------------------------------------------------------------------------------------------------|-----------------------------------------------------------------------------------------------------------------------------------------------------------------------------------------------------------------------------------------------------------------------------------------------------------------------------------------------------------------------------------------------------------------------------------------------------------------------------------------------------------------------------------------------------------------------------------------------------------------------------------------------------------------------------------------------------------------------------------------------------------------------------------------------------------------------------------------------------------------------------------------------------------------------------------------------------------------------------------------------------------------------------------------------------------------------------------------------------------------------------------------------------------------------------------------------------------------|
| <p>II. SAFETY LIMIT #2 stopped the ice machine. (Harvest time exceeded 3.5 minutes for three consecutive harvest cycles.)</p> | <ol style="list-style-type: none"> 1. Improper installation <ul style="list-style-type: none"> • Refer to Installation/Visual Inspection Checklist 2. Water system <ul style="list-style-type: none"> • Water area (evaporator) dirty • Dump valve malfunctioning/dirty • Vent tube not installed on water outlet drain • Water freezing behind evaporator • Plastic extrusions and gasket material not securely mounted to evaporator 3. Electrical system <ul style="list-style-type: none"> • Ice thickness probe out of adjustment • Ice thickness probe dirty • Bin switch defective 4. Refrigeration system <ul style="list-style-type: none"> • Non-Manitowoc components • Water regulating valve dirty/defective • Under or over refrigerant charge • Defective head pressure control valve (remotes) • Defective harvest pressure control valve (H.P.R.) valve (remotes) • Defective hot gas valve • TXV flooding (check bulb mounting) • Defective fan cycling control |

| CONDITION FOUND | POSSIBLE CAUSE |
|--------------------------------------------------------------------------------------------------------------------------------------------------------------|------------------------------------------------------------------------------------------------------------------------------------------------------------------------------------------------------------------------------------------------------------------------------------------------------------------------------------------------------------------------------------------------------------------------------------------------------------------------------------------------------------------------------------------------------------------------------------------------------------------------------------------------------------------------------------------------------------------------------------------------------------------------------------------------------------------------------------------------------------------------------------------------------------------------------------------------------------------------------------------------------------------------------------------------------------------------|
| <p>III. SAFETY LIMIT #3 stopped the ice machine. (Compressor discharge temperature fell below 85°F /29.4°C for three consecutive harvest cycles.)</p> | <ol style="list-style-type: none"> 1. Improper installation <ul style="list-style-type: none"> • Refer to Installation/Visual Inspection Checklist 2. Ice thickness set too thin or too thick 3. Water system - loss or restricted water flow over evaporator <ul style="list-style-type: none"> • Incoming water pressure low • Loss of water from sump area • Dirty (clogged) water distributing tube • Dirty/defective float valve • Dirty/defective water dump valve • Defective water pump 4. Refrigeration system <ul style="list-style-type: none"> • Non-Manitowoc components • Defective head pressure control valve (remotes) • Defective harvest pressure regulating (H.P.R.) valve (remotes) • Defective fan cycle control • Under or over refrigerant charge • Defective hot gas valve • Flooding TXV (check bulb mounting) 5. Defective thermistor |

| CONDITION FOUND | POSSIBLE CAUSE |
|-------------------------------------------------------------------------------------------------------------------------------------------------------|--------------------------------------------------------------------------------------------------------------------------------------------------------------------------------------------------------------------------------------------------------------------------------------------------------------------------------------------------------------------------------------------------------------------------------------------------------------------------------------------------------------------------------------------------------------------------------------------------------------------------------------------------------------------------------------------------------------------------------------------------------------------------------------------------------------------------------------------------------------------------------------------------------------------------------------------------------------------------------------------------------------------------------------------------------------------------------------------------------------------------------------------------------------------------------------------------------------------------------------------------------------------------------------------------------------------------------------------------------------------------------------------------------------|
| <p>IV. SAFETY LIMIT #4 stopped the ice machine. (Compressor discharge temperature exceeded 255°F /123.8°C for fifteen continuous seconds.)</p> | <ol style="list-style-type: none"> 1. Improper installation <ul style="list-style-type: none"> • Refer to Installation/Visual Inspection Checklist 2. Restricted condenser air flow (air-cooled models) <ul style="list-style-type: none"> • Inlet air temperature above 110°F /43.3°C • Condenser discharge air recirculation • Dirty condenser filter • Dirty condenser fins • Defective fan cycling control • Defective fan motor 3. Restricted condenser water flow (water-cooled models) <ul style="list-style-type: none"> • Insufficient water pressure (20 psi minimum) • Inlet water temperature above 90°F /32.2°C • Dirty condenser and/or water regulating valve • Water regulating valve out of adjustment • Defective water regulating valve 4. Refrigeration system <ul style="list-style-type: none"> • Non-Manitowoc components • Defective head pressure control valve (remote models only) • Under or over refrigerant charge • Non-condensibles in refrigeration system • High side refrigerant lines (or component) restricted or plugged • TXV starving (check bulb mounting) • Defective compressor 5. Defective thermistor |

HOT GAS VALVE

GENERAL

A hot gas valve requires a critical orifice size which meters the proper amount of hot gas flow into the evaporator during the harvest cycle. **Even a slightly too large or too small orifice will cause long harvest cycles.**

An orifice which is slightly too large causes refrigerant to condense to liquid in the evaporator during harvest and can cause potential compressor damage. An orifice which is slightly too small will not allow enough hot gas into the evaporator causing low suction pressure, thus not generating enough heat for a harvest cycle.

Replace defective hot gas valves with "original" Manitowoc replacement parts only. Normally a hot gas valve can be repaired by rebuilding it instead of changing the entire valve. Refer to Parts Manual for proper valve application and rebuild kits.

ANALYZING HOT GAS VALVE

Characteristics of a hot gas valve partially open during the freeze cycle can be similar to an expansion valve or compressor problem. The best way to diagnose a hot gas valve is by using Manitowoc's Ice Machine Refrigeration System Operational Analysis Table.

The following procedure, used with the Refrigeration Failure Comparison Table, helps determine if the hot gas valve is partially open during the freeze cycle.

STEP 1 Wait for 5 minutes into the freeze cycle

STEP 2 Feel the **inlet** of the hot gas valves

STEP 3 Feel the compressor discharge line

CAUTION

Hot gas valve inlet and compressor discharge could be hot enough to burn your hand. Just "touch" it momentarily.

STEP 4 Compare the compressor discharge line temperature to the hot gas valve **inlet** temperature.

IMPORTANT

Feeling the hot gas valve outlet or across the hot gas valve for any type of comparison **will not work**. The hot gas valve outlet, being on the suction side (cool refrigerant) of the ice machine, may be cool enough to touch, even though the valve is leaking.

Examples of hot gas valve inlet/compressor discharge line temperature comparison

| Findings | Comments |
|------------------------------------------------------------------------------------------------------|-------------------------------------------------------------------------------------------------------------------------------------------------------------------------------------------------------------------------------------------------------------------------------------------|
| The inlet of hot gas valve is cool enough to touch and the compressor discharge line is hot. | This is normal as the discharge line should always be too hot to touch and the hot gas valve inlet, although too hot to touch during harvest, should be cool enough to touch after 5 minutes into the freeze cycle. |
| The inlet of hot gas valve is hot and approaches the temperature of a hot compressor discharge line. | This is an indication something is wrong, as the hot gas valve inlet did not cool down during the freeze cycle. If the compressor dome is also entirely hot, the problem is not a hot gas valve leaking, but rather something causing the compressor (and entire ice machine) to get hot. |
| Both the inlet of hot gas valve and compressor discharge line are cool enough to touch. | This is an indication something is wrong, causing the compressor discharge line to be cool to touch. This is not caused by a hot gas valve leaking. |

SINGLE EVAPORATOR ICE MACHINES COMPARE EVAPORATOR INLET TO OUTLET TEMPERATURE CHECK

The temperature of the suction line entering and leaving the evaporator by itself cannot indicate what's wrong with an ice machine. It is, however, beneficial to compare these temperatures to each other during the freeze cycle and use it along with Manitowoc's "Refrigeration System Operational Analysis Table" in determining what may be causing an ice machine malfunction.

The actual temperatures entering and leaving the evaporator varies model-by-model and changes throughout the freeze cycle. Therefore, it is difficult to document the "normal" inlet and outlet temperature readings at a given moment during the freeze cycle. The benefit is knowing the difference between the two temperatures 5 minutes into the freeze cycle.

Use the following procedure to document freeze cycle evaporator inlet and outlet temperatures.

- STEP 1** Use a quality meter capable of taking temperature readings on curved copper lines.
- STEP 2** Attach temperature meter sensing device to copper lines entering and leaving the evaporator.

IMPORTANT

Do not simply "insert" probe (or other sensing device) under insulation - it must be "attached to" and reading the **actual** temperature of the copper lines.

- STEP 3** **After 5 minutes into the freeze cycle**, record the temperature of copper lines entering and leaving the evaporator and use with other information gathered on the "Refrigeration System Operational Analysis Table" to analyze the ice machine.

Temperature Findings
(After 5 minutes into freeze cycle)

Evaporator Inlet

Evaporator Outlet

Difference

DUAL EVAPORATOR ICE MACHINES COMPARE LEFT TO RIGHT EVAPORATOR INLET TEMPERATURES CHECK

The temperatures entering the left and right evaporators cannot, by themselves, indicate what's wrong with an ice machine. It is, however, beneficial to check these temperatures during the freeze cycle and use them along with Manitowoc's "Refrigeration System Operational Analysis Table" in determining what may be causing an ice machine malfunction.

The temperatures entering both evaporators vary model-by-model and change throughout the freeze cycle. Therefore, it is difficult to document the "normal" inlet temperature readings at a given moment during the freeze cycle. The benefit is knowing the difference between two temperatures after 5 minutes into the freeze cycle.

Use the following procedure to document freeze cycle evaporator inlet temperatures.

STEP 1 Use a quality meter capable of taking temperature readings on curved copper lines.

STEP 2 Attach temperature meter sensing device to copper

IMPORTANT

Do not simply "insert" probe (or other sensing device) under insulation - it must be "attached to" and reading the actual temperature of the copper lines.

lines entering both the left and the right evaporators.

STEP 3 After 5 minutes into the freeze cycle, record the temperature of copper lines entering both evaporators and use with other information gathered on the "Refrigeration System Operational Analysis Table" to analyze the ice machine.

Evaporator Inlet Temperatures
(After 5 minutes into freeze cycle)

Right Inlet

Left Inlet

Difference

ANALYZING DISCHARGE PRESSURE DURING FREEZE OR HARVEST CYCLE

STEP 1 DETERMINE THE ICE MACHINE OPERATING CONDITIONS

Air temperature entering condenser _____

Air temperature around ice machine _____

Water temperature entering float valve _____

STEP 2 REFER TO OPERATING PRESSURE CHART FOR ICE MACHINE MODELS BEING CHECKED

Using operating conditions determined in Step 1, find the published normal discharge pressures:

Freeze cycle _____ Harvest cycle _____

STEP 3 PERFORM AN ACTUAL DISCHARGE PRESSURE CHECK:

| | Freeze Cycle PSIG | Harvest Cycle PSIG |
|--------------------|----------------------|-----------------------|
| Beginning of cycle | _____ | _____ |
| Middle of cycle | _____ | _____ |
| End of cycle | _____ | _____ |

STEP 4 COMPARE THE ACTUAL DISCHARGE PRESSURE (STEP 3) WITH THE PUBLISHED DISCHARGE PRESSURE (STEP 2)

The discharge pressure is normal when the actual pressure falls between the published freeze or harvest cycle pressure range for the ice machine's operating conditions.

FREEZE CYCLE DISCHARGE PRESSURE HIGH CHECKLIST

1. Non-Manitowoc components in system
2. Improper installation
 - Refer to "Installation/Visual Inspection" Checklist
3. Restricted condenser air flow (air-cooled models)
 - Inlet air temperature above 110°F/43.3°C
 - Condenser discharge air recirculation
 - Dirty condenser filter
 - Dirty condenser fins
 - Defective fan cycling control
 - Defective fan motor
4. Restricted condenser water flow (water-cooled models)
 - Insufficient water pressure (20 psi minimum)
 - Inlet water temperature above 90°F/32.2°C
 - Dirty condenser and/or water regulating valve
 - Water regulating valve out of adjustment
 - Defective water regulating valve
5. Defective head pressure control valve (remote models)
6. Improper refrigerant charge
 - Over-charged
 - Non-condensibles in system
 - Wrong type of refrigerant
7. Restriction in high side refrigerant lines or component (before mid-condenser)

FREEZE CYCLE DISCHARGE PRESSURE LOW CHART

1. Non-Manitowoc components in system
2. Improper installation
 - Refer to "Installation/Visual Inspection" Checklist
3. Improper refrigerant charge
 - Under-charged
 - Wrong type of refrigerant
4. Defective head pressure control (remote models)
5. Water regulating valve (water-cooled condensers) :
 - a. Out of adjustment
 - b. Leaking water during harvest cycle
 - c. Defective
6. Fan cycle control defective

(continued)

| | |
|-----------------------------------------------------------------------------------------------------------------------------------------------------------------------------------------------------------|---------------------------------------------------------------------------------------------------------------------------------------------------------------------------------------------------------------------------------------------------------------------------------------------------------|
| <p>STEP 3 Perform an actual suction pressure check at the beginning, middle, and end of freeze cycle. It is also helpful to note the time during the freeze cycle that the readings are taken.</p> | <p>The gauges were connected to example ice machine and suction pressure readings taken as follows:</p> <p>PSIG</p> <p>Beginning of freeze cycle <u>46 (at 5 min.)</u></p> <p>Middle of freeze cycle <u>46 (at 10 min.)</u></p> <p>End of freeze cycle <u>40 (at 18 min.)</u></p> |
| <p>STEP 4 Compare the actual freeze cycle suction pressure (Step 3) to the published freeze cycle time and pressure comparison (Step 2B)</p> | <p>In this example, the suction pressure is considered high throughout the freeze cycle. It should have been:</p> <p>Approximately 42 PSIG (at 5 minutes)</p> <p>- not 46</p> <p>Approximately 38 PSIG (at 10 minutes)</p> <p>- not 46</p> <p>Approximately 30 PSIG (at 18 minutes)</p> <p>- not 40</p> |

(end)

ANALYZING SUCTION PRESSURE DURING HARVEST CYCLE

STEP 1 DETERMINE THE ICE MACHINE OPERATING CONDITIONS

Air temperature entering condenser _____

Air temperature around ice machine _____

Water temperature entering float valve _____

STEP 2 REFER TO OPERATING PRESSURE CHART FOR ICE MACHINE MODEL BEING CHECKED

Using operating conditions determined in Step 1, find the published normal harvest cycle suction pressure.

Published harvest cycle suction pressure _____

STEP 3 PERFORM AN ACTUAL HARVEST CYCLE SUCTION PRESSURE CHECK

PSIG

Beginning of harvest cycle _____

Middle of harvest cycle _____

End of harvest cycle _____

STEP 4 COMPARE THE ACTUAL HARVEST SUCTION PRESSURE (STEP 3) WITH THE PUBLISHED HARVEST SUCTION PRESSURE (STEP 2)

The harvest cycle suction pressure is normal when the actual pressure falls between the published pressure ranges for the ice machine operating conditions.

FREEZE CYCLE SUCTION PRESSURE HIGH CHECKLIST

1. Non-Manitowoc components in system
 2. Improper installation
 - Refer to "Installation/Visual Inspection" Checklist
 3. **IMPORTANT:** Freeze cycle discharge pressure high affecting low side
 - Refer to "Freeze Cycle Discharge Pressure High" Checklist
 4. Improper refrigerant charge
 - Over-charged
 - Wrong type of refrigerant
- Remote Ice Machines Only
5. Harvest pressure regulating solenoid (H.P.R.) leaking (This usually also causes extreme frosting on compressor.)
 6. Hot gas valve stuck open
 7. TXV flooding (check bulb mounting)
 8. Defective compressor

FREEZE CYCLE SUCTION PRESSURE LOW CHECKLIST

1. Non-Manitowoc components in system
2. Improper installation
 - Refer to "Installation/Visual Inspection" Checklist
3. **IMPORTANT:** Freeze cycle discharge pressure low affecting low side
 - Refer to "Freeze Cycle Discharge Pressure Low" Checklist
4. Improper water supply over evaporator
 - Refer to "Water System" Checklist
5. Loss of heat transfer from tubing on backside of evaporator
6. Restricted or plugged liquid line drier, or tubing in suction side of refrigeration system
7. Improper refrigerant charge
 - Under charged
 - Wrong type of refrigerant
8. Expansion valve starving (check bulb mounting)

HOW TO USE SINGLE OR DUAL EVAPORATOR REFRIGERATION SYSTEM OPERATIONAL ANALYSIS TABLES

The tables list 5 different defects that may affect the ice machine's operation. There are only 4 columns listed across the top. A low-on-charge ice machine and a starving expansion valve have very similar characteristics and are therefore listed under the same column.

Before starting, refer to "Before Beginning Service" for a few questions to ask when talking to the ice machine user.

STEP 1 COMPLETE "OPERATIONAL ANALYSIS" COLUMN.

Read **down** the left "Operational Analysis" column and perform all procedures and check all information listed. All items under "Operational Analysis" column have supporting reference material to help analyze each step.

While analyzing each item separately, you may find an "external problem" causing a good refrigeration component to appear defective. Correct problems as they are found. If the operational problem is found, it is not necessary to complete the remaining procedures.

STEP 2 ENTER CHECK MARKS (✓) IN SMALL SQUARE BOXES.

Each time the actual findings of an item under the "Operational Analysis" column matches the published findings on the table, enter a check mark in the appropriate box.

Example: After analyzing freeze cycle suction pressure, it is determined to be low. Check the symptoms listed across the freeze cycle suction column, and enter a check mark (✓) only in box marked "low". The other three boxes indicate "high", which does not match the actual finding of low.

STEP 3 ADD THE CHECK MARKS LISTED UNDER EACH COLUMN.

Add the number of check marks listed under each of the 4 columns. When completed, there will be 4 separate totals. If two columns have matching high numbers, a procedure was not performed properly and/or supporting material was not analyzed correctly. Refer to "Final Analysis" and column with highest number of check marks prior to changing refrigeration component.

Final Analysis

The column with the highest total number of check marks identifies the refrigeration problem. It is important to analyze all detailed charts, check lists, and other references to eliminate external items for causing a good refrigeration component to appear defective.

Refer to column with highest number of check marks and follow appropriate procedures below.

Column 1 - Hot Gas Valve Leaking: Normally a leaking hot gas valve can be repaired with a rebuild kit without changing the entire valve. Rebuild or replace the hot gas valve as required.

Column 2 - Low on Charge/Expansion Valve Starving: Verify the ice machine is not low on charge before replacing an expansion valve. Use the following guidelines:

NOTES:

A. Single and Dual Evaporator Ice Machines

A starving expansion valve normally only affects the freeze cycle pressures and not the harvest cycle pressures. A low refrigerant charge normally affects both freeze and harvest cycle pressures.

B. Dual Evaporator Ice Machine

A low on charge ice machine causes the right expansion valve to starve prior to the left. (The ice machine will lose ice fill on top of right evaporator before left.) As refrigerant loss progresses, the ice fill on top of left evaporator also becomes thin on top.

STEP 1 Add refrigerant charge in 2 to 4 oz. increments as a diagnostic procedure to verify a low charge.

STEP 2 If the problem is not corrected by adding charge, an expansion valve is faulty.

On dual evaporator ice machines, change only the TXV that is starving. If both TXV's are starving, the TXV's are most likely to be good and are affected by some other malfunction such as an ice machine that is low on charge.

STEP 3 If the problem is corrected by adding charge, the ice machine is low on charge. **Find the refrigerant leak!**

The ice machine must operate with proper nameplate charge. If no leak is found, the ice machine must still be evacuated and recharged using proper procedures which include charging the drier.

Column 3 - Expansion Valve Flooding: A loose or improperly mounted expansion valve bulb causes expansion valve to flood. Verify bulb mounting, insulation, etc. prior to changing valve.

On dual evaporator ice machines, by comparing the ice formation pattern analysis and temperatures entering both evaporators, the service technician should be able to tell which expansion valve is flooding. Change only the flooding expansion valve; or change both if unsure of which one is flooding.

Column 4 - Compressor: Replace the compressor (and start components).

To receive warranty credit, compressor ports must be properly sealed by crimping and soldering closed and old start components must be returned with the faulty compressor.

MANITOWOC B-MODEL SINGLE EVAPORATOR ICE MACHINE

Refrigeration System Operational Analysis Table

This table must be used with detailed charts/checklists and other references to eliminate external items (or problems) which can cause good refrigeration components to appear defective

| OPERATIONAL ANALYSIS (listed below) | 1. | 2. | 3. | 4. |
|--------------------------------------------------------------------------------------------------------|-----------------------------------------------------------------------------------------------------------------------------------------------------------------------------------------------------------------------------|-------------------------------------------------------------------------------------------------------------|------------------------------------------------------------------------------------------------------------------------------------------------------|-------------------------------------------------------------------------------------------------------------------------------------------------------------------------------------------------|
| Ice Production | Published 24 hour ice production Calculated (actual) ice production NOTE: The ice machine is operating properly if the ice production and ice formation pattern is normal | | | |
| Installation and Water System | Installation and/or water related problems can simulate a refrigeration component malfunction. Refer to "Installation/Visual Inspection Checklist" and "Water System Checklist" and correct all problems before proceeding. | | | |
| Ice Formation Pattern Refer to "Determining Ice Formation Patterns" for further details. | 1. Ice formation is extremely thin on top of evaporator -or- 2. No ice formation on entire evaporator | 1. Ice formation is extremely thin on top of evaporator -or- 2. No ice formation on entire evaporator | 1. Ice formation is normal -or- 2. Ice formation is extremely thin on bottom of evaporator -or- 3. No ice fomration on entire evaporator | 1. Ice formation is normal (It's normal for "dimples" in top ice cubes of evaporator to be more pronounced than "dimples" in ice cubes in bottom of evaporator.) -or- 2. No ice formation |

(Continued on next page)

MANITOWOC B-MODEL SINGLE EVAPORATOR ICE MACHINE

Refrigeration System Operational Analysis Table

(Continued from previous page)

| | 1. | 2. | 3. | 4. |
|------------------------------------------------------------------------------------------------------------------------------------------------------------------------------------------------------------------------------------------------------------------------------------------------------------------------------------------------------------------------|--------------------------------------------------------------------------------------------------------------------|-----------------------------------------------------------------------------------------------------|------------------------------------------------------------------------------------------------|-----------------------------------------------------------------------------------------------------|
| OPERATIONAL ANALYSIS (listed below) Safety Limits Refer to "Analyzing Safety Limits" to eliminate problems and/or components not listed on this table. After 5 minutes into freeze cycle, compare compressor discharge line temperature to the hot gas valve inlet temperature. Comp disc _____ Hot gas inlet _____ | Stops on Safety Limit 1 | Stops on Safety Limit 1 or 4 | Stops on Safety Limit 1 or 2 or 3 | Stops on Safety Limit 4 |
| | The inlet of hot gas valve is hot and approaches the temperature of a hot compressor discharge line. | The inlet of hot gas valve is cool enough to hold hand on and the compressor discharge line is hot. | Both the inlet to hot gas valve and compressor discharge line are cool enough to hold hand on. | The inlet of hot gas valve is cool enough to hold hand on and the compressor discharge line is hot. |

(Continued on next page)

MANITOWOC B-MODEL SINGLE EVAPORATOR ICE MACHINE

Refrigeration System Operational Analysis Table

(Continued from previous page)

| | 1. | 2. | 3. | 4. |
|-------------------------------------------------------------------------------------------------------------------------------------------------------------------------------------|-----------------------------------------------------------------------------------------------------------------------------------------------------------------------------------------------------------------------------------------------------------------------------------------------------------------------------------------------------------|-------------------------------------------------|-------------------------------------------------|---------------------------------------------------------|
| OPERATIONAL ANALYSIS <i>(listed below)</i> Compare inlet to outlet temperature of evaporator after 5 min. into freeze cycle Inlet _____ Outlet _____ | Inlet and outlet temperature within 7 °F of each other | Not within 7 °F and inlet is colder than outlet | Not within 7 °F and inlet is warmer than outlet | Inlet and outlet temperatures within 7 °F of each other |
| Freeze cycle discharge pressure Beginning _____ Middle _____ End _____ | Normal discharge pressure - refer to "Analyzing Discharge Pressure" to determine if normal. High or low pressure - refer to a freeze cycle high or low discharge pressure checklist to eliminate problems and/or components not listed on this table before proceeding. | | | |
| Freeze cycle suction pressure Beginning _____ Middle _____ End _____ | Normal suction pressure - suction pressure drops throughout freeze cycle. Refer to "Analyzing Suction Pressure" to determine if dropping normally. High or low suction pressure - refer to a freeze cycle high or low suction pressure checklist to eliminate problems and/or components not listed on this table before proceeding. | Low | High | High |

(Continued on next page)

MANITOWOC B-MODEL SINGLE EVAPORATOR ICE MACHINE

Refrigeration System Operational Analysis Table

(Continued from previous page)

| | 1. | 2. | 3. | 4. |
|----------------------------------------------------------------------------------------------|--------------------------------------------------------------|--------------------------------------------------------------------------|-----------------------------------------------------|---------------------------------------------------|
| OPERATIONAL ANALYSIS <i>(listed below)</i> | | | | |
| Miscellaneous Enter miscellaneous items in proper boxes. | | | | |
| Final Analysis Going downward, enter total number of boxes checked in each column. | Total boxes checked _____ HOT GAS VALVE LEAKING | Total boxes checked _____ LOW ON CHARGE - OR - TXV STARVING | Total boxes checked _____ TXV FLOODING | Total boxes checked _____ COMPRESSOR |

(End)

MANITOWOC B-MODEL DUAL EVAPORATOR ICE MACHINE

Refrigeration System Operational Analysis Table

This table must be used with detailed charts/checklists and other references to eliminate external items (or problems) which can cause good refrigeration components to appear defective.

| | 1. | 2. | 3. | 4. |
|---------------------------------------------------------------------------------------------------------------------------------|-----------------------------------------------------------------------------------------------------------------------------------------------------------------------------------------------------------------------------|------------------------------------------------------------------------------------------------------------------------|---------------------------------------------------------------------------------------------------------------------------------------------------------------------------|----------------------------------------------------------------------------------------------------------------------------------------------------------------------------------------------------------------------|
| OPERATIONAL ANALYSIS <i>(listed below)</i> | | | | |
| Ice Production | Published 24 hour ice production Calculated (actual) ice production NOTE: The ice machine is operating properly if the ice production and ice formation pattern is normal. | | | |
| Installation and Water System | Installation and/or water related problems can simulate a refrigeration component malfunction. Refer to "Installation/Visual Inspection Checklist" and "Water System Checklist" and correct all problems before proceeding. | | | |
| Ice Formation Pattern Left _____ Right _____ Refer to "Determining Ice Formation Patterns" for further details. | 1. Ice formation is extremely thin on top of one evaporator -or- 2. No ice formation on one evaporator | 1. Ice formation is extremely thin on top of one, or both evaporators -or- 2. No ice formation on one evaporator | 1. Ice formation is normal on both evaporators -or- 2. Ice formation is extremely thin on bottom of one evaporator -or- 3. No ice formation on one evaporator | 1. Ice formation is normal (It is normal for "dimples" in top ice cubes of evaporator to be more pronounced than "dimples" in ice cubes in bottom of evaporator.) -or- 2. No ice formation on both evaporators |

(Continued on next page)

MANITOWOC B-MODEL DUAL EVAPORATOR ICE MACHINE

Refrigeration System Operational Analysis Table

(Continued from previous page)

| | 1. | 2. | 3. | 4. |
|--------------------------------------------------------------------------------------------------------------------------------------------------------------------------------------------------------------------------------------------------------------------------------------------------------------------------------------------------------------------------------|--------------------------------------------------------------------------------------------------------------------|--------------------------------------------------------------------------------------------------------|--------------------------------------------------------------------------------------------------|-------------------------------------------------------------------------------------------------------------|
| OPERATIONAL ANALYSIS <i>(listed below)</i> Safety Limits Refer to "Analyzing Safety Limits" to eliminate problems and/or components not listed on this table. After 5 minutes into freeze cycle, compare compressor discharge line temperature to inlet temperature of both hot gas valves. Comp disc _____ Left _____ Right _____ | Stops on Safety Limit 1 | Stops on Safety Limit 1 or 4 | Stops on Safety Limit 1 or 2 or 3 | Stops on Safety Limit 4 |
| | The inlet of hot gas valve is hot and approaches the temperature of a hot compressor discharge line. | The inlets of both hot gas valves are cool enough to hold hand on and the compressor discharge is hot. | The inlets of both hot gas valves and compressor discharge line are cool enough to hold hand on. | The inlets of both hot gas valves are cool enough to hold hand on and the compressor discharge line is hot. |

(Continued on next page)

MANITOWOC B-MODEL DUAL EVAPORATOR ICE MACHINE

Refrigeration System Operational Analysis Table

(Continued from previous page)

| | 1. | 2. | 3. | 4. |
|------------------------------------------------------------------------------------------------------------------------------------------------------------------------------------------------------|-------------------------------------------------------------------------------------------------------------------------------------------------------------------------------------------------------------------------------------------------------------------------------------------------------------------------------------------------------|-------------------------------------------------------------------------|-------------------------------------------------------------------|-------------------------------------------------------------------------|
| OPERATIONAL ANALYSIS <i>(listed below)</i> Compare left evaporator inlet to right evaporator inlet temperatures after 5 min. into freeze cycle Left Inlet _____ Right Inlet _____ | Left and right evaporator inlet temperatures within 7 °F of each other. | Left and right evaporator inlet temperatures within 7 °F of each other. | Not within 7 °F . Warmer temperature indicates flooding valve. | Left and right evaporator inlet temperatures within 7 °F of each other. |
| Freeze cycle discharge pressure Beginning _____ Middle _____ End _____ | Normal discharge pressure - refer to "Analyzing Discharge Pressure" to determine if normal. High or low discharge pressure - refer to a freeze cycle high or low discharge pressure checklist to eliminate problems and/or components not listed on this table before proceeding. | | | |
| Freeze cycle suction pressure Beginning _____ Middle _____ End _____ | Normal suction pressure - suction pressure drops throughout freeze cycle. Refer to "Analyzing Suction Pressure" to determine if dropping normally. High or low suction pressure - refer to a freeze cycle high or low suction pressure checklist to eliminate problems and/or components not listed on this table before proceeding. | | | |
| | High | Low | High | High |

(Continued on next page)

MANITOWOC B-MODEL DUAL EVAPORATOR ICE MACHINE

Refrigeration System Operational Analysis Table

(Continued from previous page)

| | 1. | 2. | 3. | 4. |
|----------------------------------------------------------------------------------------------------|------------------------------------------------------------------|----------------------------------------------------------------------------|-----------------------------------------------------|---------------------------------------------------|
| OPERATIONAL ANALYSIS <i>(listed below)</i> | | | | |
| Miscellaneous Enter miscellaneous items in proper boxes. | | | | |
| Final Analysis Going downward, enter total number of boxes checked in each column. | Total boxes checked _____ HOT GAS VALVE LEAKING | Total boxes checked _____ LOW ON CHARGE -OR- TXV STARVING | Total boxes checked _____ TXV FLOODING | Total boxes checked _____ COMPRESSOR |

(End)

REFRIGERATION TUBING SCHEMATIC SELF-CONTAINED AIR OR WATER-COOLED MODELS B150

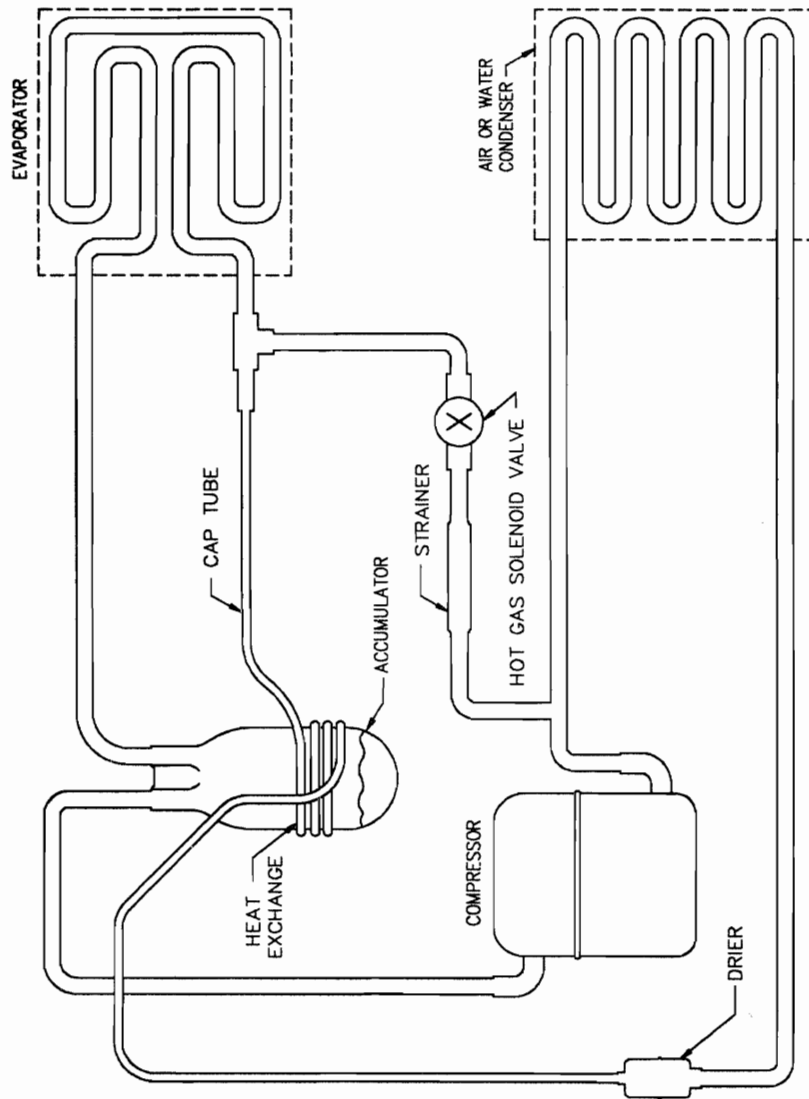

SV 1350

**REFRIGERATION TUBING SCHEMATIC
SELF-CONTAINED AIR OR WATER-COOLED MODELS
B200/B250/B320/B420/B450/B600/B800/B1000**

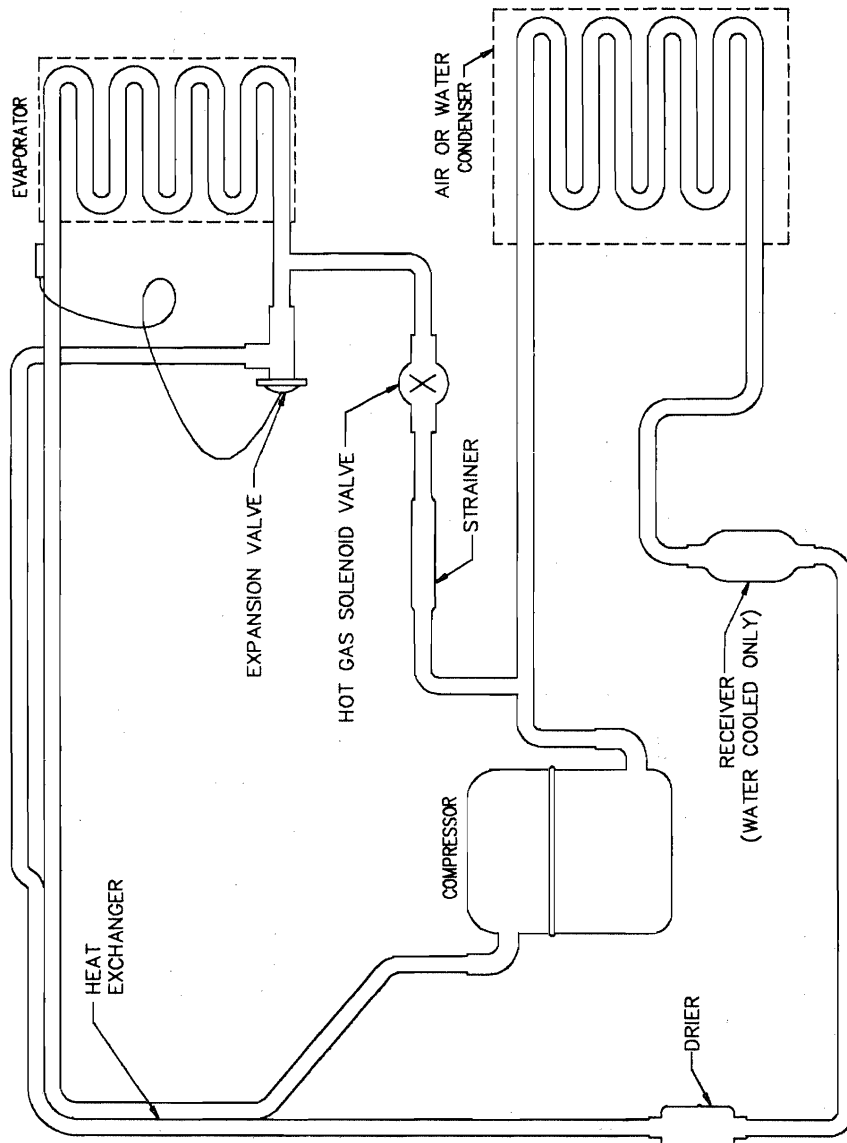

SV 1353

**REFRIGERATION TUBING SCHEMATIC
SELF-CONTAINED AIR OR WATER-COOLED MODELS
B1300/B1800**

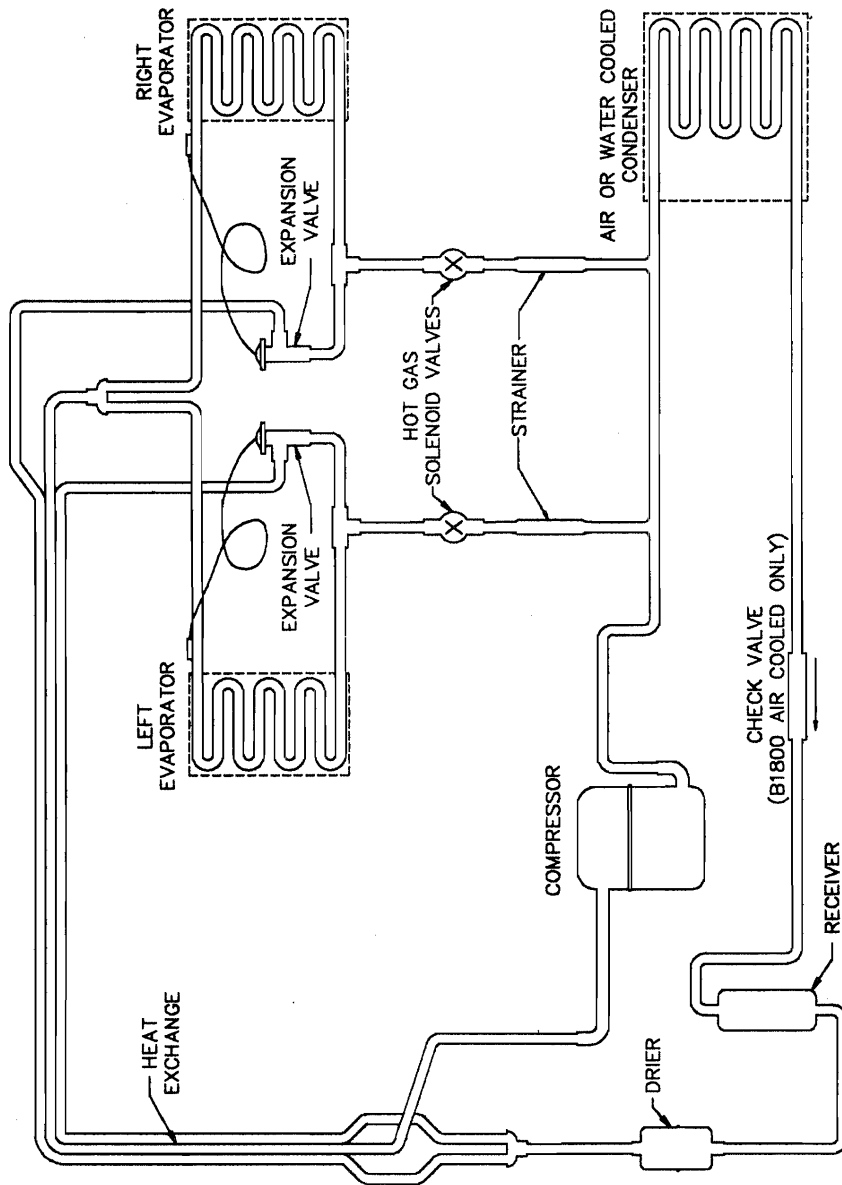

SV 1358

**REFRIGERATION TUBING SCHEMATIC
REMOTE MODELS
B450/B600/B800/B1000**

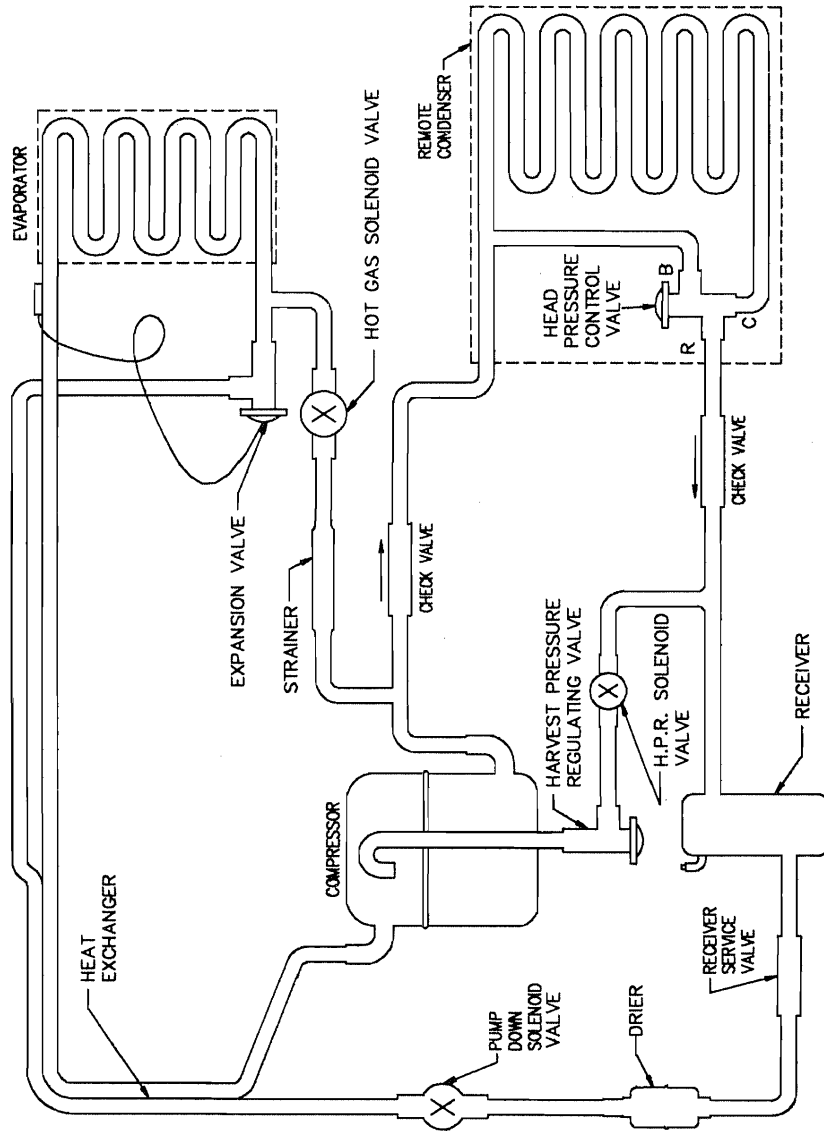

SV 1354

**REFRIGERATION TUBING SCHEMATIC
REMOTE MODELS
B1300/B1800**

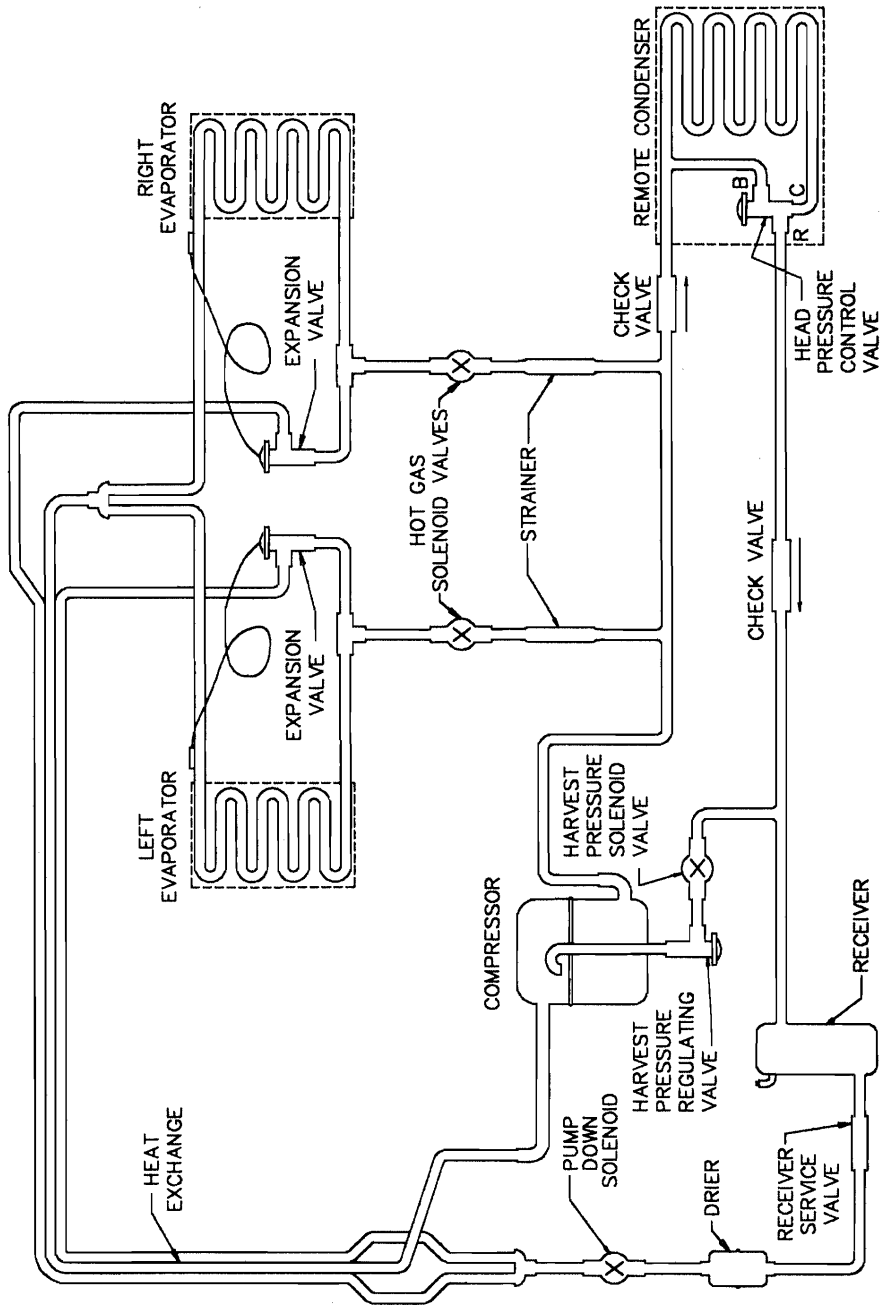

SV 1359

B150 SERIES SELF CONTAINED AIR-COOLED

These characteristics may vary depending on operating conditions.

CYCLE TIMES

Freeze Time + Harvest Time = Total Cycle Time

| AIR TEMP. ENTERING CONDENSER °F/°C | FREEZE TIME | | | HARVEST TIME |
|------------------------------------------|-------------------|-----------|-----------|-----------------|
| | WATER TEMP. °F/°C | | | |
| | 50/10.0 | 70/21.1 | 90/32.2 | |
| 70/21.1 | 15.3-17.6 | 17.7-20.3 | 20.9-23.3 | 1-2.5 |
| 80/26.7 | 15.9-18.2 | 18.4-21.1 | 21.9-25.1 | |
| 90/32.2 | 17.7-20.3 | 20.9-23.3 | 25.4-29.0 | |
| 100/37.8 | 20.0-22.9 | 24.1-27.6 | 30.1-34.4 | |

Based on average ice slab weight of 1.87 lb. to 2.12 lb.
Times in minutes

24 HOUR ICE PRODUCTION

| AIR TEMP. ENTERING CONDENSER °F/°C | WATER TEMP. °F/°C | | |
|---------------------------------------|-------------------|---------|---------|
| | 50/10.0 | 70/21.1 | 90/32.2 |
| 70/21.1 | 160 | 140 | 120 |
| 80/26.7 | 155 | 135 | 115 |
| 90/32.2 | 140 | 120 | 100 |
| 100/37.8 | 125 | 105 | 85 |

Regular cube derate 7%

OPERATING PRESSURES

| AIR TEMP. ENTERING CONDENSER °F/°C | FREEZE CYCLE | | HARVEST CYCLE | |
|---------------------------------------------|--------------------------|-----------------------------|--------------------------|-----------------------------|
| | HEAD PRESSURE PSIG | SUCTION PRESSURE PSIG | HEAD PRESSURE PSIG | SUCTION PRESSURE PSIG |
| 50/10.0 | 200-250 | 36-26 | 170-200 | 80-95 |
| 70/21.1 | 200-250 | 36-26 | 170-200 | 80-95 |
| 80/26.7 | 200-250 | 36-26 | 180-210 | 85-100 |
| 90/32.2 | 230-280 | 38-28 | 200-230 | 90-105 |
| 100/37.8 | 280-330 | 40-30 | 220-250 | 100-115 |
| 110/43.3 | 310-380 | 42-32 | 240-270 | 110-125 |

* Suction pressure drops gradually throughout freeze cycle

B150 SERIES WATER-COOLED

These characteristics may vary depending on operating conditions.

CYCLE TIMES

Freeze Time + Harvest Time = Total Cycle Time

| AIR TEMP. AROUND ICE MACHINE °F/°C | FREEZE TIME | | | HARVEST TIME |
|---------------------------------------------------|--------------------------|----------------|----------------|-------------------------|
| | WATER TEMP. °F/°C | | | |
| | 50/10.0 | 70/21.1 | 90/32.2 | |
| 70/21.1 | 13.9-16.0 | 17.1-19.6 | 20.0-22.9 | 1-2.5 |
| 80/26.7 | 14.3-16.5 | 17.7-20.3 | 20.9-23.3 | |
| 90/32.2 | 14.3-16.5 | 17.7-20.3 | 20.9-23.3 | |
| 100/37.8 | 14.8-17.0 | 18.4-21.1 | 21.9-25.1 | |

Based on average ice slab weight of 1.87 lb. to 2.12 lb.
Times in minutes

24 HOUR ICE PRODUCTION

| AIR TEMP. AROUND ICE MACHINE °F/°C | WATER TEMP. °F/°C | | |
|-----------------------------------------------|--------------------------|----------------|----------------|
| | 50/10.0 | 70/21.1 | 90/32.2 |
| 70/21.1 | 175 | 145 | 125 |
| 80/26.7 | 170 | 140 | 120 |
| 90/32.2 | 170 | 140 | 120 |
| 100/37.8 | 165 | 135 | 115 |

Regular cube derate 7%

| CONDENSER WATER CONSUMPTION | 90/32.2 AIR TEMPERATURE | | |
|--------------------------------------------|--------------------------------|----------------|----------------|
| | WATER TEMPERATURE °F/°C | | |
| | 50/10.0 | 70/21.1 | 90/32.2 |
| Gal/24 hours | 150 | 260 | 1650 |

At 225 PSIG head pressure

OPERATING PRESSURES

| AIR TEMP. AROUND ICE MACHINE °F/°C | FREEZE CYCLE | | HARVEST CYCLE | |
|-------------------------------------------------------|-----------------------------------|--------------------------------------|-----------------------------------|--------------------------------------|
| | HEAD PRESSURE PSIG | SUCTION PRESSURE PSIG | HEAD PRESSURE PSIG | SUCTION PRESSURE PSIG |
| 50/10.0 | 220-230 | 36-28 | 150-180 | 80-95 |
| 70/21.1 | 220-230 | 36-28 | 150-180 | 85-100 |
| 80/26.7 | 220-230 | 36-28 | 150-180 | 85-100 |
| 90/32.2 | 220-230 | 36-28 | 160-190 | 90-105 |
| 100/37.8 | 220-230 | 36-28 | 170-200 | 90-105 |
| 110/43.3 | 220-230 | 36-28 | 170-200 | 95-110 |

* Suction pressure drops gradually throughout freeze cycle

B200 SERIES SELF CONTAINED AIR-COOLED

These characteristics may vary depending on operating conditions.

CYCLE TIMES

Freeze Time + Harvest Time = Total Cycle Time

| AIR TEMP. ENTERING CONDENSER °F/°C | FREEZE TIME | | | HARVEST TIME |
|------------------------------------------|-------------------|-----------|-----------|-----------------|
| | WATER TEMP. °F/°C | | | |
| | 50/10.0 | 70/21.1 | 90/32.2 | |
| 70/21.1 | 12.6-14.7 | 14.8-17.3 | 16.5-19.3 | 1-2.5 |
| 80/26.7 | 13.8-16.1 | 16.5-19.3 | 18.6-21.6 | |
| 90/32.2 | 15.2-17.8 | 18.6-21.6 | 21.2-24.6 | |
| 100/37.8 | 17.5-20.4 | 21.9-25.5 | 25.5-29.6 | |

Based on average ice slab weight of 2.44 lb. to 2.81 lb.
Times in minutes

24 HOUR ICE PRODUCTION

| AIR TEMP. ENTERING CONDENSER °F/°C | WATER TEMP. °F/°C | | |
|---------------------------------------|-------------------|---------|---------|
| | 50/10.0 | 70/21.1 | 90/32.2 |
| 70/21.1 | 250 | 215 | 195 |
| 80/26.7 | 230 | 195 | 175 |
| 90/32.2 | 210 | 175 | 155 |
| 100/37.8 | 185 | 150 | 130 |

Regular cube derate 7%

OPERATING PRESSURES

| AIR TEMP. ENTERING CONDENSER °F/°C | FREEZE CYCLE | | HARVEST CYCLE | |
|---------------------------------------------|--------------------------|-----------------------------|--------------------------|-----------------------------|
| | HEAD PRESSURE PSIG | SUCTION PRESSURE PSIG | HEAD PRESSURE PSIG | SUCTION PRESSURE PSIG |
| 50/10.0 | 200-250 | 48-28 | 120-150 | 75-90 |
| 70/21.1 | 200-250 | 48-28 | 120-150 | 80-95 |
| 80/26.7 | 210-270 | 50-28 | 120-150 | 85-100 |
| 90/32.2 | 240-300 | 54-30 | 130-160 | 90-105 |
| 100/37.8 | 270-350 | 60-32 | 130-160 | 95-110 |
| 110/43.3 | 300-390 | 64-32 | 140-170 | 100-115 |

* Suction pressure drops gradually throughout freeze cycle

B200 SERIES WATER-COOLED

These characteristics may vary depending on operating conditions.

CYCLE TIMES

Freeze Time + Harvest Time = Total Cycle Time

| AIR TEMP. AROUND ICE MACHINE °F/°C | FREEZE TIME | | | HARVEST TIME |
|------------------------------------------|-------------------|-----------|-----------|-----------------|
| | WATER TEMP. °F/°C | | | |
| | 50/10.0 | 70/21.1 | 90/32.2 | |
| 70/21.1 | 13.1-15.4 | 15.2-17.8 | 18.6-21.6 | 1-2.5 |
| 80/26.7 | 13.1-15.4 | 15.2-17.8 | 18.6-21.6 | |
| 90/32.2 | 13.5-15.7 | 15.6-18.2 | 19.2-22.3 | |
| 100/37.8 | 13.5-15.7 | 15.6-18.2 | 19.2-22.3 | |

Based on average ice slab weight of 2.44 lb. to 2.81 lb.
Times in minutes

24 HOUR ICE PRODUCTION

| AIR TEMP. AROUND ICE MACHINE °F/°C | WATER TEMP. °F/°C | | |
|---------------------------------------|-------------------|---------|---------|
| | 50/10.0 | 70/21.1 | 90/32.2 |
| 70/21.1 | 240 | 210 | 175 |
| 80/26.7 | 240 | 210 | 175 |
| 90/32.2 | 235 | 205 | 170 |
| 100/37.8 | 235 | 205 | 170 |

Regular cube derate 7%

| CONDENSER WATER CONSUMPTION | 90/32.2 AIR TEMPERATURE | | |
|-----------------------------------|-------------------------|---------|---------|
| | WATER TEMPERATURE °F/°C | | |
| | 50/10.0 | 70/21.1 | 90/32.2 |
| Gal/24 hours | 175 | 325 | 1750 |

At 230 PSIG head pressure

OPERATING PRESSURES

| AIR TEMP. AROUND ICE MACHINE °F/°C | FREEZE CYCLE | | HARVEST CYCLE | |
|---------------------------------------------|--------------------------|-----------------------------|--------------------------|-----------------------------|
| | HEAD PRESSURE PSIG | SUCTION PRESSURE PSIG | HEAD PRESSURE PSIG | SUCTION PRESSURE PSIG |
| 50/10.0 | 225-235 | 48-28 | 130-160 | 80-95 |
| 70/21.1 | 225-235 | 48-28 | 130-160 | 80-95 |
| 80/26.7 | 225-235 | 50-28 | 130-160 | 85-100 |
| 90/32.2 | 225-235 | 50-28 | 140-170 | 85-100 |
| 100/37.8 | 225-245 | 50-30 | 140-170 | 90-105 |
| 110/43.3 | 225-255 | 50-30 | 150-180 | 90-105 |

* Suction pressure drops gradually throughout freeze cycle

B250 SERIES SELF CONTAINED AIR-COOLED

These characteristics may vary depending on operating conditions.

CYCLE TIMES

Freeze Time + Harvest Time = Total Cycle Time

| AIR TEMP. ENTERING CONDENSER °F/°C | FREEZE TIME | | | HARVEST TIME |
|------------------------------------------|-------------------|-----------|-----------|-----------------|
| | WATER TEMP. °F/°C | | | |
| | 50/10.0 | 70/21.1 | 90/32.2 | |
| 70/21.1 | 12.0-14.1 | 13.8-16.1 | 15.6-18.2 | 1-2.5 |
| 80/26.7 | 12.8-15.0 | 14.8-17.3 | 17.0-19.8 | |
| 90/32.2 | 14.8-17.3 | 17.5-20.4 | 20.5-23.8 | |
| 100/37.8 | 16.5-19.3 | 19.8-23.0 | 23.6-27.4 | |

Based on average ice slab weight of 2.44 lb. to 2.81 lb.
Times in minutes

24 HOUR ICE PRODUCTION

| AIR TEMP. ENTERING CONDENSER °F/°C | WATER TEMP. °F/°C | | |
|---------------------------------------|-------------------|---------|---------|
| | 50/10.0 | 70/21.1 | 90/32.2 |
| 70/21.1 | 260 | 230 | 205 |
| 80/26.7 | 245 | 215 | 190 |
| 90/32.2 | 215 | 185 | 160 |
| 100/37.8 | 195 | 165 | 140 |

Regular cube derate 7%

OPERATING PRESSURES

| AIR TEMP. ENTERING CONDENSER °F/°C | FREEZE CYCLE | | HARVEST CYCLE | |
|---------------------------------------------|--------------------------|-----------------------------|--------------------------|-----------------------------|
| | HEAD PRESSURE PSIG | SUCTION PRESSURE PSIG | HEAD PRESSURE PSIG | SUCTION PRESSURE PSIG |
| 50/10.0 | 200-250 | 48-28 | 170-200 | 75-90 |
| 70/21.1 | 200-250 | 48-28 | 170-200 | 75-90 |
| 80/26.7 | 220-280 | 48-30 | 180-210 | 85-95 |
| 90/32.2 | 250-310 | 50-32 | 190-220 | 90-105 |
| 100/37.8 | 290-350 | 52-34 | 210-240 | 100-120 |
| 110/43.3 | 320-380 | 54-36 | 260-270 | 110-130 |

* Suction pressure drops gradually throughout freeze cycle

B250 SERIES WATER-COOLED

These characteristics may vary depending on operating conditions.

CYCLE TIMES

Freeze Time + Harvest Time = Total Cycle Time

| AIR TEMP. AROUND ICE MACHINE °F/°C | FREEZE TIME | | | HARVEST TIME |
|------------------------------------------|-------------------|-----------|-----------|-----------------|
| | WATER TEMP. °F/°C | | | |
| | 50/10.0 | 70/21.1 | 90/32.2 | |
| 70/21.1 | 12.6-14.7 | 14.8-17.3 | 17.0-19.8 | 1-2.5 |
| 80/26.7 | 12.6-14.7 | 14.8-17.3 | 17.0-19.8 | |
| 90/32.2 | 12.8-15.0 | 15.2-17.8 | 17.5-20.4 | |
| 100/37.8 | 12.8-15.0 | 15.2-17.8 | 17.5-20.4 | |

Based on average ice slab weight of 2.44 lb. to 2.81 lb.
Times in minutes

24 HOUR ICE PRODUCTION

| AIR TEMP. AROUND ICE MACHINE °F/°C | WATER TEMP. °F/°C | | |
|---------------------------------------|-------------------|---------|---------|
| | 50/10.0 | 70/21.1 | 90/32.2 |
| 70/21.1 | 250 | 215 | 190 |
| 80/26.7 | 250 | 215 | 190 |
| 90/32.2 | 245 | 210 | 185 |
| 100/37.8 | 245 | 210 | 185 |

Regular cube derate 7%

| CONDENSER WATER CONSUMPTION | 90/32.2 AIR TEMPERATURE | | |
|-----------------------------------|-------------------------|---------|---------|
| | WATER TEMPERATURE °F/°C | | |
| | 50/10.0 | 70/21.1 | 90/32.2 |
| Gal/24 hours | 190 | 360 | 1300 |

At 225 PSIG head pressure

OPERATING PRESSURES

| AIR TEMP. AROUND ICE MACHINE °F/°C | FREEZE CYCLE | | HARVEST CYCLE | |
|---------------------------------------------|--------------------------|-----------------------------|--------------------------|-----------------------------|
| | HEAD PRESSURE PSIG | SUCTION PRESSURE PSIG | HEAD PRESSURE PSIG | SUCTION PRESSURE PSIG |
| 50/10.0 | 220-230 | 48-28 | 170-200 | 80-95 |
| 70/21.1 | 220-230 | 48-28 | 170-200 | 85-95 |
| 80/26.7 | 220-230 | 50-30 | 180-210 | 85-100 |
| 90/32.2 | 220-230 | 50-30 | 180-210 | 85-100 |
| 100/37.8 | 220-230 | 50-30 | 180-210 | 85-100 |
| 110/43.3 | 220-230 | 52-33 | 180-210 | 90-105 |

* Suction pressure drops gradually throughout freeze cycle

B320 SERIES SELF CONTAINED AIR-COOLED

These characteristics may vary depending on operating conditions.

CYCLE TIMES

Freeze Time + Harvest Time = Total Cycle Time

| AIR TEMP. ENTERING CONDENSER °F/°C | FREEZE TIME | | | HARVEST TIME |
|------------------------------------------|-------------------|-----------|-----------|-----------------|
| | WATER TEMP. °F/°C | | | |
| | 50/10.0 | 70/21.1 | 90/32.2 | |
| 70/21.1 | 11.3-12.9 | 12.6-14.4 | 14.1-16.1 | 1-2.5 |
| 80/26.7 | 12.6-14.4 | 14.1-16.1 | 16.1-18.4 | |
| 90/32.2 | 14.1-16.1 | 16.1-18.4 | 18.6-21.2 | |
| 100/37.8 | 16.1-18.4 | 18.6-21.2 | 21.9-25.0 | |

Based on average ice slab weight of 2.93 lb. to 3.31 lb.
Times in minutes

24 HOUR ICE PRODUCTION

| AIR TEMP. ENTERING CONDENSER °F/°C | WATER TEMP. °F/°C | | |
|---------------------------------------|-------------------|---------|---------|
| | 50/10.0 | 70/21.1 | 90/32.2 |
| 70/21.1 | 330 | 300 | 270 |
| 80/26.7 | 300 | 270 | 240 |
| 90/32.2 | 270 | 240 | 210 |
| 100/37.8 | 240 | 210 | 180 |

Regular cube derate 7%

OPERATING PRESSURES

| AIR TEMP. ENTERING CONDENSER °F/°C | FREEZE CYCLE | | HARVEST CYCLE | |
|---------------------------------------------|--------------------------|-----------------------------|--------------------------|-----------------------------|
| | HEAD PRESSURE PSIG | SUCTION PRESSURE PSIG | HEAD PRESSURE PSIG | SUCTION PRESSURE PSIG |
| 50/10.0 | 200-250 | 50-36 | 150-180 | 75-90 |
| 70/21.1 | 200-250 | 50-36 | 160-190 | 80-95 |
| 80/26.7 | 210-260 | 50-36 | 170-200 | 85-100 |
| 90/32.2 | 230-280 | 52-38 | 180-210 | 90-105 |
| 100/37.8 | 260-330 | 54-40 | 200-230 | 100-115 |
| 110/43.3 | 280-360 | 56-42 | 220-250 | 110-125 |

* Suction pressure drops gradually throughout freeze cycle

B320 SERIES WATER-COOLED

These characteristics may vary depending on operating conditions.

CYCLE TIMES

Freeze Time + Harvest Time = Total Cycle Time

| AIR TEMP. AROUND ICE MACHINE °F/°C | FREEZE TIME | | | HARVEST TIME |
|---------------------------------------------------|--------------------------|----------------|----------------|-------------------------|
| | WATER TEMP. °F/°C | | | |
| | 50/10.0 | 70/21.1 | 90/32.2 | |
| 70/21.1 | 12.3-14.1 | 14.7-16.8 | 17.7-20.2 | 1-2.5 |
| 80/26.7 | 12.6-14.4 | 15.1-17.2 | 18.1-20.7 | |
| 90/32.2 | 12.8-14.7 | 15.8-17.6 | 18.6-21.2 | |
| 100/37.8 | 13.1-14.9 | 15.7-18.0 | 19.1-21.8 | |

Based on average ice slab weight of 2.93 lb. to 3.31 lb.
Times in minutes

24 HOUR ICE PRODUCTION

| AIR TEMP. AROUND ICE MACHINE °F/°C | WATER TEMP. °F/°C | | |
|-----------------------------------------------|--------------------------|----------------|----------------|
| | 50/10.0 | 70/21.1 | 90/32.2 |
| 70/21.1 | 305 | 260 | 220 |
| 80/26.7 | 300 | 255 | 215 |
| 90/32.2 | 295 | 250 | 210 |
| 100/37.8 | 290 | 245 | 205 |

Regular cube derate 7%

| CONDENSER WATER CONSUMPTION °F/°C | 90/32.2 AIR TEMPERATURE | | |
|--------------------------------------------------|--------------------------------|----------------|----------------|
| | WATER TEMPERATURE °F/°C | | |
| | 50/10.0 | 70/21.1 | 90/32.2 |
| Gal/24 hours | 230 | 410 | 1665 |

At 230 PSIG head pressure

OPERATING PRESSURES

| AIR TEMP. AROUND ICE MACHINE °F/°C | FREEZE CYCLE | | HARVEST CYCLE | |
|-------------------------------------------------------|-----------------------------------|--------------------------------------|-----------------------------------|--------------------------------------|
| | HEAD PRESSURE PSIG | SUCTION PRESSURE PSIG | HEAD PRESSURE PSIG | SUCTION PRESSURE PSIG |
| 50/10.0 | 215-225 | 50-36 | 150-180 | 75-90 |
| 70/21.1 | 215-225 | 50-36 | 160-190 | 80-95 |
| 80/26.7 | 215-225 | 50-36 | 160-190 | 85-100 |
| 90/32.2 | 215-225 | 50-36 | 170-200 | 85-100 |
| 100/37.8 | 220-240 | 52-36 | 170-200 | 90-105 |
| 110/43.3 | 220-240 | 52-36 | 180-210 | 95-110 |

* Suction pressure drops gradually throughout freeze cycle

B420/B450 SERIES SELF CONTAINED AIR-COOLED

These characteristics may vary depending on operating conditions.

CYCLE TIMES

Freeze Time + Harvest Time = Total Cycle Time

| AIR TEMP. ENTERING CONDENSER °F/°C | FREEZE TIME | | | HARVEST TIME |
|------------------------------------------|-------------------|-----------|-----------|-----------------|
| | WATER TEMP. °F/°C | | | |
| | 50/10.0 | 70/21.1 | 90/32.2 | |
| 70/21.1 | 11.1-13.1 | 12.6-14.8 | 14.5-17.0 | 1-2.5 |
| 80/26.7 | 11.7-13.7 | 13.3-15.6 | 17.0-18.1 | |
| 90/32.2 | 13.3-15.6 | 15.5-18.1 | 18.3-21.3 | |
| 100/37.8 | 15.0-17.5 | 17.6-20.6 | 20.5-23.8 | |

Based on average ice slab weight of 4.12 lb. to 4.75 lb.
Times in minutes

24 HOUR ICE PRODUCTION

| AIR TEMP. ENTERING CONDENSER °F/°C | WATER TEMP. °F/°C | | |
|---------------------------------------|-------------------|---------|---------|
| | 50/10.0 | 70/21.1 | 90/32.2 |
| 70/21.1 | 470 | 420 | 370 |
| 80/26.7 | 450 | 400 | 350 |
| 90/32.2 | 400 | 350 | 300 |
| 100/37.8 | 360 | 310 | 270 |

Regular cube derate 7%

OPERATING PRESSURES

| AIR TEMP. ENTERING CONDENSER °F/°C | FREEZE CYCLE | | HARVEST CYCLE | |
|---------------------------------------------|--------------------------|-----------------------------|--------------------------|-----------------------------|
| | HEAD PRESSURE PSIG | SUCTION PRESSURE PSIG | HEAD PRESSURE PSIG | SUCTION PRESSURE PSIG |
| 50/10.0 | 200-250 | 44-30 | 140-170 | 85-100 |
| 70/21.1 | 200-250 | 46-30 | 150-180 | 90-105 |
| 80/26.7 | 200-250 | 46-30 | 160-190 | 95-110 |
| 90/32.2 | 230-280 | 46-30 | 170-200 | 100-115 |
| 100/37.8 | 270-330 | 48-32 | 200-230 | 110-125 |
| 110/43.3 | 300-360 | 54-36 | 230-270 | 120-135 |

* Suction pressure drops gradually throughout freeze cycle

B420/B450 SERIES WATER-COOLED

These characteristics may vary depending on operating conditions.

CYCLE TIMES

Freeze Time + Harvest Time = Total Cycle Time

| AIR TEMP. AROUND ICE MACHINE °F/°C | FREEZE TIME | | | HARVEST TIME |
|------------------------------------------|-------------------|-----------|-----------|-----------------|
| | WATER TEMP. °F/°C | | | |
| | 50/10.0 | 70/21.1 | 90/32.2 | |
| 70/21.1 | 12.0-14.1 | 13.3-15.6 | 15.2-17.8 | 1-2.5 |
| 80/26.7 | 12.1-14.2 | 13.5-15.8 | 15.5-18.1 | |
| 90/32.2 | 12.3-14.4 | 13.7-16.0 | 15.7-18.3 | |
| 100/37.8 | 12.6-14.8 | 14.1-16.5 | 16.2-18.9 | |

Based on average ice slab weight of 4.12 lb. to 4.75 lb.
Times in minutes

24 HOUR ICE PRODUCTION

| AIR TEMP. AROUND ICE MACHINE °F/°C | WATER TEMP. °F/°C | | |
|---------------------------------------|-------------------|---------|---------|
| | 50/10.0 | 70/21.1 | 90/32.2 |
| 70/21.1 | 440 | 400 | 355 |
| 80/26.7 | 435 | 395 | 350 |
| 90/32.2 | 430 | 390 | 345 |
| 100/37.8 | 420 | 380 | 335 |

Regular cube derate 7%
Based on average ice slab weight of 4.12 lb to 4.75 lb.

| CONDENSER WATER CONSUMPTION | 90/32.2 AIR TEMPERATURE | | |
|-----------------------------------|-------------------------|---------|---------|
| | WATER TEMPERATURE °F/°C | | |
| | 50/10.0 | 70/21.1 | 90/32.2 |
| Gal/24 hours | 315 | 580 | 2800 |

At 230 PSIG head pressure

OPERATING PRESSURES

| AIR TEMP. AROUND ICE MACHINE °F/°C | FREEZE CYCLE | | HARVEST CYCLE | |
|---------------------------------------------|--------------------------|-----------------------------|--------------------------|-----------------------------|
| | HEAD PRESSURE PSIG | SUCTION PRESSURE PSIG | HEAD PRESSURE PSIG | SUCTION PRESSURE PSIG |
| 50/10.0 | 225-235 | 48-30 | 175-200 | 90-105 |
| 70/21.1 | 225-235 | 48-30 | 175-200 | 95-110 |
| 80/26.7 | 225-235 | 48-30 | 175-200 | 95-110 |
| 90/37.8 | 225-235 | 48-30 | 175-200 | 100-115 |
| 100/32.8 | 230-240 | 48-30 | 185-210 | 100-115 |
| 110/43.3 | 230-240 | 50-32 | 185-210 | 100-115 |

* Suction pressure drops gradually throughout freeze cycle

B450 SERIES REMOTE

These characteristics may vary depending on operating conditions.

CYCLE TIMES

Freeze Time + Harvest Time = Total Cycle Time

| AIR TEMP. ENTERING CONDENSER °F/°C | FREEZE TIME | | | HARVEST TIME |
|------------------------------------------|-------------------|-----------|-----------|-----------------|
| | WATER TEMP. °F/°C | | | |
| | 50/10.0 | 70/21.1 | 90/32.2 | |
| -20 to 70/-28.9 to 21.1 | 12.6-14.8 | 14.5-17.0 | 16.5-19.2 | 1-2.5 |
| 80/26.7 | 12.8-15.0 | 14.8-17.2 | 16.8-19.6 | |
| 90/32.2 | 13.0-15.2 | 15.0-17.5 | 17.0-19.9 | |
| 100/37.8 | 13.3-15.6 | 15.5-18.1 | 17.6-20.6 | |
| 110/43.3 | 14.1-16.5 | 15.9-18.6 | 18.3-21.3 | |

Based on average ice slab weight of 4.12 lb. to 4.75 lb.
Times in minutes

24 HOUR ICE PRODUCTION

| AIR TEMP. ENTERING CONDENSER °F/°C | WATER TEMP. °F/°C | | |
|---------------------------------------|-------------------|---------|---------|
| | 50/10.0 | 70/21.1 | 90/32.2 |
| -20 to 70/-28.4 to 21.1 | 420 | 370 | 330 |
| 90/32.2 | 410 | 360 | 320 |
| 100/37.8 | 400 | 350 | 310 |
| 110/43.3 | 380 | 340 | 300 |

Regular cube derate 7%

Rating using BC0495 condenser, dice or half-dice cubes

OPERATING PRESSURES

| AIR TEMP. ENTERING CONDENSER °F/°C | FREEZE CYCLE | | HARVEST CYCLE | |
|---------------------------------------------|--------------------------|-----------------------------|--------------------------|-----------------------------|
| | HEAD PRESSURE PSIG | SUCTION PRESSURE PSIG | HEAD PRESSURE PSIG | SUCTION PRESSURE PSIG |
| -20 to 50/ -28.9 to 10.0 | 220-250 | 46-30 | 150-180 | 85-100 |
| 70/21.1 | 220-250 | 46-30 | 150-180 | 85-100 |
| 80/26.7 | 230-260 | 48-30 | 150-180 | 85-100 |
| 90/32.2 | 240-270 | 50-32 | 150-180 | 85-100 |
| 100/37.8 | 250-290 | 50-32 | 160-190 | 90-105 |
| 110/43.3 | 280-330 | 52-34 | 160-190 | 95-110 |

* Suction pressure drops gradually throughout freeze cycle

B600 SERIES SELF CONTAINED AIR-COOLED

These characteristics may vary depending on operating conditions.

CYCLE TIMES

Freeze Time + Harvest Time = Total Cycle Time

| AIR TEMP. ENTERING CONDENSER °F/°C | FREEZE TIME | | | HARVEST TIME |
|------------------------------------------|-------------------|-----------|-----------|-----------------|
| | WATER TEMP. °F/°C | | | |
| | 50/10.0 | 70/21.1 | 90/32.2 | |
| 70/21.1 | 7.2-8.6 | 8.4-9.9 | 9.5-11.2 | 1-2.5 |
| 80/26.7 | 7.8-9.2 | 9.1-10.7 | 10.4-12.2 | |
| 90/32.2 | 8.6-10.1 | 10.1-11.9 | 12.0-14.1 | |
| 100/37.8 | 9.7-11.4 | 11.7-13.7 | 14.1-16.5 | |

Based on average ice slab weight of 4.12 lb. to 4.75 lb.
Times in minutes

24 HOUR ICE PRODUCTION

| AIR TEMP. ENTERING CONDENSER °F/°C | WATER TEMP. °F/°C | | |
|---------------------------------------|-------------------|---------|---------|
| | 50/10.0 | 70/21.1 | 90/32.2 |
| 70/21.1 | 680 | 600 | 540 |
| 80/26.7 | 640 | 560 | 500 |
| 90/32.2 | 590 | 510 | 440 |
| 100/37.8 | 530 | 450 | 380 |

Regular cube derate 7%

OPERATING PRESSURES

| AIR TEMP. ENTERING CONDENSER °F/°C | FREEZE CYCLE | | HARVEST CYCLE | |
|---------------------------------------------|--------------------------|-----------------------------|--------------------------|-----------------------------|
| | HEAD PRESSURE PSIG | SUCTION PRESSURE PSIG | HEAD PRESSURE PSIG | SUCTION PRESSURE PSIG |
| 50/10.0 | 200-250 | 40-22 | 130-160 | 75-90 |
| 70/21.1 | 200-250 | 40-22 | 140-170 | 80-95 |
| 80/26.7 | 210-260 | 44-24 | 150-180 | 85-100 |
| 90/32.2 | 230-290 | 46-24 | 160-190 | 90-105 |
| 100/37.8 | 260-330 | 50-28 | 180-210 | 100-115 |
| 110/43.3 | 310-380 | 55-36 | 200-240 | 120-135 |

* Suction pressure drops gradually throughout freeze cycle

B600 SERIES WATER-COOLED

These characteristics may vary depending on operating conditions.

CYCLE TIMES

Freeze Time + Harvest Time = Total Cycle Time

| AIR TEMP. AROUND ICE MACHINE °F/°C | FREEZE TIME | | | HARVEST TIME |
|------------------------------------------|-------------------|----------|-----------|-----------------|
| | WATER TEMP. °F/°C | | | |
| | 50/10.0 | 70/21.1 | 90/32.2 | |
| 70/21.1 | 7.6-9.0 | 8.9-10.5 | 10.4-12.2 | 1-2.5 |
| 80/26.7 | 7.8-9.2 | 9.1-10.7 | 10.6-12.5 | |
| 90/32.2 | 7.9-9.4 | 9.3-10.9 | 10.9-12.8 | |
| 100/37.8 | 8.1-9.5 | 9.5-11.2 | 11.1-13.1 | |

Based on average ice slab weight of 4.12 lb. to 4.75 lb.
Times in minutes

24 HOUR ICE PRODUCTION

| AIR TEMP. AROUND ICE MACHINE °F/°C | WATER TEMP. °F/°C | | |
|---------------------------------------|-------------------|---------|---------|
| | 50/10.0 | 70/21.1 | 90/32.2 |
| 70/21.1 | 650 | 570 | 500 |
| 80/26.7 | 640 | 560 | 490 |
| 90/32.2 | 630 | 550 | 480 |
| 100/37.8 | 620 | 540 | 470 |

Regular cube derate 7%

Based on average ice slab weight of 4.12 lb to 4.75 lb.

| CONDENSER WATER CONSUMPTION | 90/32.2 AIR TEMPERATURE | | |
|-----------------------------------|-------------------------|---------|---------|
| | WATER TEMPERATURE °F/°C | | |
| | 50/10.0 | 70/21.1 | 90/32.2 |
| Gal/24 hours | 410 | 740 | 3100 |

At 230 PSIG head pressure

OPERATING PRESSURES

| AIR TEMP. AROUND ICE MACHINE °F/°C | FREEZE CYCLE | | HARVEST CYCLE | |
|---------------------------------------------|--------------------------|-----------------------------|--------------------------|-----------------------------|
| | HEAD PRESSURE PSIG | SUCTION PRESSURE PSIG | HEAD PRESSURE PSIG | SUCTION PRESSURE PSIG |
| 50/10.0 | 225-235 | 40-24 | 150-180 | 85-100 |
| 70/21.1 | 225-235 | 40-24 | 150-180 | 85-100 |
| 80/26.7 | 225-235 | 42-24 | 160-190 | 90-105 |
| 90/32.2 | 225-235 | 42-24 | 160-190 | 95-110 |
| 100/37.8 | 225-235 | 44-26 | 170-200 | 95-110 |
| 110/43.3 | 230-240 | 44-26 | 180-210 | 95-110 |

* Suction pressure drops gradually throughout freeze cycle

B600 SERIES REMOTE

These characteristics may vary depending on operating conditions.

CYCLE TIMES

Freeze Time + Harvest Time = Total Cycle Time

| AIR TEMP. ENTERING CONDENSER °F/°C | FREEZE TIME | | | HARVEST TIME |
|------------------------------------------|-------------------|-----------|-----------|-----------------|
| | WATER TEMP. °F/°C | | | |
| | 50/10.0 | 70/21.1 | 90/32.2 | |
| -20 to 70/-28.9 to 21.1 | 8.1-9.5 | 9.5-11.2 | 10.9-12.8 | 1-2.5 |
| 80/26.7 | 8.2-9.7 | 9.7-11.4 | 11.1-13.1 | |
| 90/32.2 | 8.4-9.9 | 9.9-11.7 | 11.4-13.4 | |
| 100/37.8 | 8.7-10.3 | 10.4-12.2 | 12.0-14.1 | |
| 110/43.3 | 9.7-11.4 | 11.1-13.1 | 13.0-15.2 | |

Based on average ice slab weight of 4.12 lb. to 4.75 lb.
Times in minutes

24 HOUR ICE PRODUCTION

| AIR TEMP. ENTERING CONDENSER °F/°C | WATER TEMP. °F/°C | | |
|---------------------------------------|-------------------|---------|---------|
| | 50/10.0 | 70/21.1 | 90/32.2 |
| -20 to 70/-28.9 to 21.1 | 620 | 540 | 480 |
| 90/32.2 | 600 | 520 | 460 |
| 100/37.8 | 580 | 500 | 440 |
| 110/43.3 | 530 | 470 | 410 |

Regular cube derate 7%

Rating using BC0895 condenser, dice or half-dice cubes

OPERATING PRESSURES

| AIR TEMP. ENTERING CONDENSER °F/°C | FREEZE CYCLE | | HARVEST CYCLE | |
|---------------------------------------------|--------------------------|-----------------------------|--------------------------|-----------------------------|
| | HEAD PRESSURE PSIG | SUCTION PRESSURE PSIG | HEAD PRESSURE PSIG | SUCTION PRESSURE PSIG |
| -20 to 50/ -28.9 to 10.0 | 220-250 | 44-26 | 140-170 | 80-95 |
| 70/21.1 | 220-250 | 44-26 | 150-180 | 85-100 |
| 80/26.7 | 220-250 | 44-26 | 150-180 | 85-100 |
| 90/32.2 | 230-260 | 46-28 | 150-180 | 90-105 |
| 100/37.8 | 250-290 | 48-30 | 150-180 | 90-105 |
| 110/43.3 | 280-330 | 54-32 | 160-190 | 95-110 |

* Suction pressure drops gradually throughout freeze cycle

B800 SERIES SELF CONTAINED AIR-COOLED

These characteristics may vary depending on operating conditions.

CYCLE TIMES

Freeze Time + Harvest Time = Total Cycle Time

| AIR TEMP. ENTERING CONDENSER F°/°C | FREEZE TIME | | | HARVEST TIME |
|------------------------------------------|-------------------|-----------|-----------|-----------------|
| | WATER TEMP. °F/°C | | | |
| | 50/10.0 | 70/21.1 | 90/32.2 | |
| 70/21.1 | 8.6-9.9 | 10.0-11.5 | 11.2-12.9 | 1-2.5 |
| 80/26.7 | 8.7-10.1 | 10.2-11.7 | 11.4-13.1 | |
| 90/32.2 | 9.3-10.7 | 10.9-12.5 | 12.3-14.1 | |
| 100/37.8 | 10.7-12.3 | 12.8-14.6 | 14.7-16.9 | |

Based on average ice slab weight of 5.75 lb. to 6.50 lb.
Times in minutes

24 HOUR ICE PRODUCTION

| AIR TEMP. ENTERING CONDENSER °F/°C | WATER TEMP. °F/°C | | |
|---------------------------------------|-------------------|---------|---------|
| | 50/10.0 | 70/21.1 | 90/32.2 |
| 70/21.1 | 820 | 720 | 650 |
| 80/26.7 | 810 | 710 | 640 |
| 90/32.2 | 770 | 670 | 600 |
| 100/37.8 | 680 | 580 | 510 |

Regular cube derate 7%

OPERATING PRESSURES

| AIR TEMP. ENTERING CONDENSER °F/°C | FREEZE CYCLE | | HARVEST CYCLE | |
|---------------------------------------------|--------------------------|-----------------------------|--------------------------|-----------------------------|
| | HEAD PRESSURE PSIG | SUCTION PRESSURE PSIG | HEAD PRESSURE PSIG | SUCTION PRESSURE PSIG |
| 50/10.0 | 200-240 | 35-20 | 140-170 | 65-80 |
| 70/21.1 | 200-240 | 35-20 | 140-170 | 65-80 |
| 80/26.7 | 220-260 | 35-20 | 150-180 | 70-85 |
| 90/32.2 | 250-300 | 40-22 | 160-190 | 75-90 |
| 100/37.8 | 280-330 | 42-24 | 180-210 | 80-95 |
| 110/43.3 | 310-350 | 44-26 | 200-230 | 85-100 |

* Suction pressure drops gradually throughout freeze cycle

B800 SERIES WATER-COOLED

These characteristics may vary depending on operating conditions.

CYCLE TIMES

Freeze Time + Harvest Time = Total Cycle Time

| AIR TEMP. AROUND ICE MACHINE °F/°C | FREEZE TIME | | | HARVEST TIME |
|------------------------------------------|-------------------|----------|-----------|-----------------|
| | WATER TEMP. °F/°C | | | |
| | 50/10.0 | 70/21.1 | 90/32.2 | |
| 70/21.1 | 8.4-9.6 | 9.3-10.7 | 11.1-12.7 | 1-2.5 |
| 80/26.7 | 8.4-9.7 | 9.3-10.7 | 11.1-12.8 | |
| 90/32.2 | 8.5-9.8 | 9.4-10.8 | 11.2-12.9 | |
| 100/37.8 | 8.5-9.9 | 9.5-10.9 | 11.3-13.0 | |

Based on average ice slab weight of 5.75 lb. to 6.50 lb.
Times in minutes

24 HOUR ICE PRODUCTION

| AIR TEMP. AROUND ICE MACHINE °F/°C | WATER TEMP. °F/°C | | |
|---------------------------------------|-------------------|---------|---------|
| | 50/10.0 | 70/21.1 | 90/32.2 |
| 70/21.1 | 840 | 770 | 660 |
| 80/26.7 | 835 | 765 | 655 |
| 90/32.2 | 830 | 760 | 650 |
| 100/37.8 | 825 | 755 | 645 |

Regular cube derate 7%

| CONDENSER WATER CONSUMPTION °F/°C | 90/32.2 AIR TEMPERATURE | | |
|--------------------------------------------|-------------------------|---------|---------|
| | WATER TEMPERATURE °F/°C | | |
| | 50/10.0 | 70/21.1 | 90/32.2 |
| Gal/24 hours | 500 | 1000 | 2025 |

At 220 PSIG head pressure

OPERATING PRESSURES

| AIR TEMP. AROUND ICE MACHINE °F/°C | FREEZE CYCLE | | HARVEST CYCLE | |
|---------------------------------------------|--------------------------|-----------------------------|--------------------------|-----------------------------|
| | HEAD PRESSURE PSIG | SUCTION PRESSURE PSIG | HEAD PRESSURE PSIG | SUCTION PRESSURE PSIG |
| 50/10.0 | 215-225 | 35-20 | 140-170 | 70-85 |
| 70/21.1 | 215-225 | 35-20 | 140-170 | 70-85 |
| 80/26.7 | 215-225 | 35-20 | 140-170 | 70-85 |
| 90/37.8 | 215-225 | 36-22 | 150-180 | 70-85 |
| 100/32.8 | 220-230 | 38-22 | 150-180 | 70-85 |
| 110/43.3 | 220-240 | 38-24 | 160-190 | 70-85 |

* Suction pressure drops gradually throughout freeze cycle

B800 SERIES REMOTE

These characteristics may vary depending on operating conditions.

CYCLE TIMES

Freeze Time + Harvest Time = Total Cycle Time

| AIR TEMP. ENTERING CONDENSER °F/°C | FREEZE TIME | | | HARVEST TIME |
|---------------------------------------------------|--------------------------|----------------|----------------|-------------------------|
| | WATER TEMP. °F/°C | | | |
| | 50/10.0 | 70/21.1 | 90/32.2 | |
| -20 to 70/-28.9 to 21.1 | 8.9-10.2 | 10.2-11.7 | 11.9-13.6 | 1-2.5 |
| 80/26.7 | 8.9-10.3 | 10.2-11.8 | 12.0-13.7 | |
| 90/32.2 | 9.0-10.3 | 10.3-11.9 | 12.1-13.8 | |
| 100/37.8 | 9.5-11.0 | 11.1-12.7 | 13.0-14.9 | |
| 110/43.3 | 10.7-12.3 | 12.5-14.4 | 15.1-17.2 | |

Based on average ice slab weight of 5.75 lb. to 6.50 lb.
Times in minutes

24 HOUR ICE PRODUCTION

| AIR TEMP. ENTERING CONDENSER °F/°C | WATER TEMP. °F/°C | | |
|-----------------------------------------------|--------------------------|----------------|----------------|
| | 50/10.0 | 70/21.1 | 90/32.2 |
| -20 to 70/-28.9 to 21.1 | 800 | 710 | 620 |
| 90/32.2 | 790 | 700 | 610 |
| 100/37.8 | 750 | 660 | 570 |
| 110/43.3 | 680 | 590 | 500 |

Regular cube derate 7%

Rating using BC0895 condenser, dice or half-dice cubes

OPERATING PRESSURES

| AIR TEMP. ENTERING CONDENSER °F/°C | FREEZE CYCLE | | HARVEST CYCLE | |
|-------------------------------------------------------|-----------------------------------|--------------------------------------|-----------------------------------|--------------------------------------|
| | HEAD PRESSURE PSIG | SUCTION PRESSURE PSIG | HEAD PRESSURE PSIG | SUCTION PRESSURE PSIG |
| -20 to 50/ -28.9 to 10.0 | 220-250 | 38-22 | 160-190 | 80-95 |
| 70/21.1 | 220-250 | 38-22 | 160-190 | 80-95 |
| 80/26.7 | 225-260 | 38-22 | 160-190 | 80-95 |
| 90/32.2 | 230-270 | 40-22 | 170-200 | 85-100 |
| 100/37.8 | 250-300 | 40-24 | 180-210 | 90-105 |
| 110/43.3 | 290-340 | 42-26 | 190-220 | 95-110 |

* Suction pressure drops gradually throughout freeze cycle

B1000 SERIES SELF CONTAINED AIR-COOLED

These characteristics may vary depending on operating conditions.

CYCLE TIMES

Freeze Time + Harvest Time = Total Cycle Time

| AIR TEMP. ENTERING CONDENSER F°/°C | FREEZE TIME | | | HARVEST TIME |
|------------------------------------------|-------------------|-----------|-----------|-----------------|
| | WATER TEMP. °F/°C | | | |
| | 50/10.0 | 70/21.1 | 90/32.2 | |
| 70/21.1 | 8.9-9.6 | 10.0-10.8 | 11.3-12.2 | 1-2.5 |
| 80/26.7 | 9.2-9.9 | 10.4-11.1 | 11.8-12.6 | |
| 90/32.2 | 10.0-10.8 | 11.3-12.2 | 13.0-13.9 | |
| 100/37.8 | 11.3-12.2 | 13.0-13.9 | 15.2-16.2 | |

Based on average ice slab weight of 7.75 lb. to 8.25 lb.
Times in minutes

24 HOUR ICE PRODUCTION

| AIR TEMP. ENTERING CONDENSER °F/°C | WATER TEMP. °F/°C | | |
|---------------------------------------|-------------------|---------|---------|
| | 50/10.0 | 70/21.1 | 90/32.2 |
| 70/21.1 | 1070 | 970 | 870 |
| 80/26.7 | 1040 | 940 | 840 |
| 90/32.2 | 970 | 870 | 770 |
| 100/37.8 | 870 | 770 | 670 |

Regular cube derate 7%

OPERATING PRESSURES

| AIR TEMP. ENTERING CONDENSER °F/°C | FREEZE CYCLE | | HARVEST CYCLE | |
|---------------------------------------------|--------------------------|-----------------------------|--------------------------|-----------------------------|
| | HEAD PRESSURE PSIG | SUCTION PRESSURE PSIG | HEAD PRESSURE PSIG | SUCTION PRESSURE PSIG |
| 50/10.0 | 200-250 | 38-20 | 140-170 | 75-90 |
| 70/21.1 | 200-250 | 40-20 | 140-170 | 75-90 |
| 80/26.7 | 210-270 | 40-20 | 150-180 | 75-90 |
| 90/32.2 | 230-300 | 42-22 | 170-200 | 85-100 |
| 100/37.8 | 260-340 | 44-22 | 200-230 | 95-110 |
| 110/43.3 | 280-360 | 46-22 | 210-240 | 100-115 |

* Suction pressure drops gradually throughout freeze cycle

B1000 SERIES WATER-COOLED

These characteristics may vary depending on operating conditions.

CYCLE TIMES

Freeze Time + Harvest Time = Total Cycle Time

| AIR TEMP. AROUND ICE MACHINE °F/°C | FREEZE TIME | | | HARVEST TIME |
|------------------------------------------|-------------------|-----------|-----------|-----------------|
| | WATER TEMP. °F/°C | | | |
| | 50/10.0 | 70/21.1 | 90/32.2 | |
| 70/21.1 | 8.8-9.5 | 9.7-10.4 | 10.9-11.7 | 1-2.5 |
| 80/26.7 | 9.0-9.7 | 9.9-10.6 | 11.2-12.0 | |
| 90/32.2 | 9.2-9.9 | 10.1-10.9 | 11.5-12.3 | |
| 100/37.8 | 9.3-10.0 | 10.2-11.0 | 11.6-12.5 | |

Based on average ice slab weight of 7.75 lb. to 8.25 lb.
Times in minutes

24 HOUR ICE PRODUCTION

| AIR TEMP. AROUND ICE MACHINE °F/°C | WATER TEMP. °F/°C | | |
|---------------------------------------|-------------------|---------|---------|
| | 50/10.0 | 70/21.1 | 90/32.2 |
| 70/21.1 | 1080 | 1000 | 900 |
| 80/26.7 | 1060 | 980 | 880 |
| 90/32.2 | 1040 | 960 | 860 |
| 100/37.8 | 1030 | 950 | 850 |

Regular cube derate 7%

| CONDENSER WATER CONSUMPTION °F/°C | 90/32.2 AIR TEMPERATURE | | |
|--------------------------------------------|-------------------------|---------|---------|
| | WATER TEMPERATURE °F/°C | | |
| | 50/10.0 | 70/21.1 | 90/32.2 |
| Gal/24 hours | 725 | 1275 | 4250 |

At 230 PSIG head pressure

OPERATING PRESSURES

| AIR TEMP. AROUND ICE MACHINE °F/°C | FREEZE CYCLE | | HARVEST CYCLE | |
|---------------------------------------------|--------------------------|-----------------------------|--------------------------|-----------------------------|
| | HEAD PRESSURE PSIG | SUCTION PRESSURE PSIG | HEAD PRESSURE PSIG | SUCTION PRESSURE PSIG |
| 50/10.0 | 225-235 | 38-20 | 150-180 | 75-90 |
| 70/21.1 | 225-235 | 38-20 | 150-180 | 75-90 |
| 80/26.7 | 225-235 | 38-20 | 160-190 | 80-95 |
| 90/32.2 | 225-235 | 40-22 | 170-200 | 85-100 |
| 100/37.8 | 225-235 | 40-22 | 180-210 | 85-100 |
| 110/43.3 | 230-240 | 40-22 | 180-210 | 90-105 |

* Suction pressure drops gradually throughout freeze cycle

B1000 SERIES REMOTE

These characteristics may vary depending on operating conditions.

CYCLE TIMES

Freeze Time + Harvest Time = Total Cycle Time

| AIR TEMP. ENTERING CONDENSER °F/°C | FREEZE TIME | | | HARVEST TIME |
|---------------------------------------------------|--------------------------|----------------|----------------|-------------------------|
| | WATER TEMP. °F/°C | | | |
| | 50/10.0 | 70/21.1 | 90/32.2 | |
| -20 to 70/ -28.9 to 21.1 | 9.0-9.7 | 10.2-11.0 | 11.6-12.5 | 1-2.5 |
| 80/26.7 | 9.1-9.8 | 10.4-11.1 | 11.8-12.6 | |
| 90/32.2 | 9.1-9.8 | 10.5-11.3 | 12.0-12.8 | |
| 100/37.8 | 9.4-10.2 | 10.8-11.6 | 12.3-13.2 | |
| 110/43.3 | 10.4-11.1 | 11.0-11.9 | 13.2-14.1 | |

Based on average ice slab weight of 7.75 lb. to 8.25 lb.
Times in minutes

24 HOUR ICE PRODUCTION

| AIR TEMP. ENTERING CONDENSER °F/°C | WATER TEMP. °F/°C | | |
|-----------------------------------------------|--------------------------|----------------|----------------|
| | 50/10.0 | 70/21.1 | 90/32.2 |
| -20 to 70/ -28.9 to 21.1 | 1060 | 950 | 850 |
| 90/32.2 | 1050 | 930 | 830 |
| 100/37.8 | 1020 | 910 | 810 |
| 110/43.3 | 940 | 890 | 760 |

Regular cube derate 7%

Rating using BC1095 condenser, dice or half-dice cubes

OPERATING PRESSURES

| AIR TEMP. ENTERING CONDENSER °F/°C | FREEZE CYCLE | | HARVEST CYCLE | |
|-------------------------------------------------------|-----------------------------------|--------------------------------------|-----------------------------------|--------------------------------------|
| | HEAD PRESSURE PSIG | SUCTION PRESSURE PSIG | HEAD PRESSURE PSIG | SUCTION PRESSURE PSIG |
| -20 to 50/ -28.9 to 10.0 | 220-250 | 38-24 | 150-180 | 75-90 |
| 70/21.1 | 220-250 | 38-24 | 160-190 | 75-90 |
| 80/26.7 | 220-250 | 38-24 | 160-190 | 80-95 |
| 90/32.2 | 240-280 | 40-24 | 170-200 | 85-100 |
| 100/37.8 | 250-300 | 40-24 | 180-210 | 90-105 |
| 110/43.3 | 300-350 | 42-26 | 190-220 | 95-110 |

* Suction pressure drops gradually throughout freeze cycle

B1300 SERIES SELF CONTAINED AIR-COOLED

These characteristics may vary depending on operating conditions.

CYCLE TIMES

Freeze Time + Harvest Time = Total Cycle Time

| AIR TEMP. ENTERING CONDENSER °F/°C | FREEZE TIME | | | HARVEST TIME |
|------------------------------------------|-------------------|-----------|-----------|-----------------|
| | WATER TEMP. °F/°C | | | |
| | 50/10.0 | 70/21.1 | 90/32.2 | |
| 70/21.1 | 11.5-13.1 | 12.6-14.3 | 13.9-15.7 | 1-2.5 |
| 80/26.7 | 12.5-14.1 | 13.6-15.4 | 15.2-17.2 | |
| 90/32.2 | 13.5-15.3 | 14.9-16.8 | 16.7-18.9 | |
| 100/37.8 | 15.8-17.9 | 17.9-20.2 | 20.5-23.1 | |

Based on average ice slab weight of 12.5 lb. to 14 lb.
Times in minutes

24 HOUR ICE PRODUCTION

| AIR TEMP. ENTERING CONDENSER °F/°C | WATER TEMP. °F/°C | | |
|---------------------------------------|-------------------|---------|---------|
| | 50/10.0 | 70/21.1 | 90/32.2 |
| 70/21.1 | 1380 | 1280 | 1170 |
| 80/26.7 | 1290 | 1190 | 1080 |
| 90/32.2 | 1200 | 1100 | 990 |
| 100/37.8 | 1040 | 930 | 820 |

Regular cube derate 7%

OPERATING PRESSURES

| AIR TEMP. ENTERING CONDENSER °F/°C | FREEZE CYCLE | | HARVEST CYCLE | |
|---------------------------------------------|--------------------------|-----------------------------|--------------------------|-----------------------------|
| | HEAD PRESSURE PSIG | SUCTION PRESSURE PSIG | HEAD PRESSURE PSIG | SUCTION PRESSURE PSIG |
| 50/10.0 | 200-250 | 40-22 | 140-170 | 70-85 |
| 70/21.1 | 200-250 | 40-22 | 140-170 | 70-85 |
| 80/26.7 | 200-250 | 42-24 | 150-180 | 75-90 |
| 90/32.2 | 230-280 | 44-26 | 160-190 | 80-95 |
| 100/37.8 | 270-330 | 46-28 | 170-200 | 90-105 |
| 110/43.3 | 300-380 | 48-30 | 180-210 | 95-110 |

* Suction pressure drops gradually throughout freeze cycle

B1300 SERIES WATER-COOLED

These characteristics may vary depending on operating conditions.

CYCLE TIMES

Freeze Time + Harvest Time = Total Cycle Time

| AIR TEMP. AROUND ICE MACHINE °F/°C | FREEZE TIME | | | HARVEST TIME |
|------------------------------------------|-------------------|-----------|-----------|-----------------|
| | WATER TEMP. °F/°C | | | |
| | 50/10.0 | 70/21.1 | 90/32.2 | |
| 70/21.1 | 11.0-12.5 | 12.2-13.9 | 14.3-16.2 | 1-2.5 |
| 80/26.7 | 11.2-12.7 | 12.6-14.3 | 14.8-16.7 | |
| 90/32.2 | 11.4-13.0 | 12.9-14.6 | 15.3-17.3 | |
| 100/37.8 | 11.8-13.4 | 13.4-15.2 | 16.0-18.1 | |

Based on average ice slab weight of 12.5 lb. to 14 lb.
Times in minutes

24 HOUR ICE PRODUCTION

| AIR TEMP. AROUND ICE MACHINE °F/°C | WATER TEMP. °F/°C | | |
|---------------------------------------|-------------------|---------|---------|
| | 50/10.0 | 70/21.1 | 90/32.2 |
| 70/21.1 | 1440 | 1310 | 1140 |
| 80/26.7 | 1420 | 1280 | 1110 |
| 90/32.2 | 1390 | 1250 | 1070 |
| 100/37.8 | 1350 | 1210 | 1030 |

Regular cube derate 7%

| CONDENSER WATER CONSUMPTION °F/°C | 90/32.2 AIR TEMPERATURE | | |
|--------------------------------------------|-------------------------|---------|---------|
| | WATER TEMPERATURE °F/°C | | |
| | 50/10.0 | 70/21.1 | 90/32.2 |
| Gal/24 hours | 985 | 1650 | 4750 |

At 230 PSIG head pressure

OPERATING PRESSURES

| AIR TEMP. AROUND ICE MACHINE °F/°C | FREEZE CYCLE | | HARVEST CYCLE | |
|---------------------------------------------|--------------------------|-----------------------------|--------------------------|-----------------------------|
| | HEAD PRESSURE PSIG | SUCTION PRESSURE PSIG | HEAD PRESSURE PSIG | SUCTION PRESSURE PSIG |
| 50/10.0 | 225-235 | 40-22 | 130-160 | 70-85 |
| 70/21.1 | 225-235 | 40-22 | 130-160 | 70-85 |
| 80/26.7 | 225-235 | 40-22 | 130-160 | 70-85 |
| 90/32.2 | 225-235 | 40-22 | 130-160 | 70-85 |
| 100/37.8 | 225-235 | 40-22 | 130-160 | 70-85 |
| 110/43.3 | 230-240 | 40-22 | 140-170 | 70-85 |

* Suction pressure drops gradually throughout freeze cycle

B1300 SERIES REMOTE

These characteristics may vary depending on operating conditions.

CYCLE TIMES

Freeze Time + Harvest Time = Total Cycle Time

| AIR TEMP. ENTERING CONDENSER °F/°C | FREEZE TIME | | | HARVEST TIME |
|---------------------------------------------------|--------------------------|----------------|----------------|-------------------------|
| | WATER TEMP. °F/°C | | | |
| | 50/10.0 | 70/21.1 | 90/32.2 | |
| -20 to 70/ -28.9 to 21.1 | 11.7-13.3 | 13.3-15.0 | 14.8-16.7 | 1-2.5 |
| 80/26.7 | 11.8-13.4 | 13.3-15.1 | 14.8-16.7 | |
| 90/32.2 | 11.8-13.4 | 13.4-15.2 | 14.9-16.8 | |
| 100/37.8 | 12.8-14.5 | 14.0-15.9 | 15.6-17.7 | |
| 110/43.3 | 12.9-14.6 | 14.8-16.7 | 16.5-18.7 | |

Based on average ice slab weight of 12.5 lb. to 14 lb.
Times in minutes

24 HOUR ICE PRODUCTION

| AIR TEMP. ENTERING CONDENSER °F/°C | WATER TEMP. °F/°C | | |
|-----------------------------------------------|--------------------------|----------------|----------------|
| | 50/10.0 | 70/21.1 | 90/32.2 |
| -20 to 70/ -28.9 to 21.1 | 1360 | 1220 | 1110 |
| 90/32.2 | 1350 | 1210 | 1100 |
| 100/37.8 | 1260 | 1160 | 1050 |
| 110/43.3 | 1250 | 1110 | 1000 |

Regular cube derate 7%

Rating using BC1095 condenser, dice or half-dice cubes

OPERATING PRESSURES

| AIR TEMP. ENTERING CONDENSER °F/°C | FREEZE CYCLE | | HARVEST CYCLE | |
|-------------------------------------------------------|-----------------------------------|--------------------------------------|-----------------------------------|--------------------------------------|
| | HEAD PRESSURE PSIG | SUCTION PRESSURE PSIG | HEAD PRESSURE PSIG | SUCTION PRESSURE PSIG |
| -20 to 50/ -28.9 to 10.0 | 220-250 | 40-24 | 140-170 | 75-90 |
| 70/21.1 | 220-250 | 40-24 | 140-170 | 75-90 |
| 80/26.7 | 220-250 | 40-26 | 140-170 | 75-90 |
| 90/32.2 | 240-270 | 40-26 | 140-170 | 75-90 |
| 100/37.8 | 260-300 | 42-28 | 150-180 | 80-95 |
| 110/43.3 | 300-340 | 44-30 | 160-190 | 80-95 |

* Suction pressure drops gradually throughout freeze cycle

B1800 SERIES SELF CONTAINED AIR-COOLED

These characteristics may vary depending on operating conditions.

CYCLE TIMES

Freeze Time + Harvest Time = Total Cycle Time

| AIR TEMP. ENTERING CONDENSER F°/°C | FREEZE TIME | | | HARVEST TIME |
|------------------------------------------|-------------------|-----------|-----------|-----------------|
| | WATER TEMP. °F/°C | | | |
| | 50/10.0 | 70/21.1 | 90/32.2 | |
| 70/21.1 | 10.3-11.1 | 11.6-12.5 | 12.6-13.5 | 1-2.5 |
| 80/26.7 | 10.8-11.6 | 12.3-13.2 | 13.4-14.3 | |
| 90/32.2 | 12.4-13.3 | 14.2-15.2 | 15.7-16.8 | |
| 100/37.8 | 14.0-15.0 | 16.4-17.5 | 18.3-19.5 | |

Based on average ice slab weight of 15.5 lb. to 16.5 lb.
Times in minutes

24 HOUR ICE PRODUCTION

| AIR TEMP. ENTERING CONDENSER °F/°C | WATER TEMP. °F/°C | | |
|---------------------------------------|-------------------|---------|---------|
| | 50/10.0 | 70/21.1 | 90/32.2 |
| 70/21.1 | 1890 | 1700 | 1580 |
| 80/26.7 | 1810 | 1620 | 1500 |
| 90/32.2 | 1610 | 1420 | 1300 |
| 100/37.8 | 1440 | 1250 | 1130 |

Regular cube derate 7%

OPERATING PRESSURES

| AIR TEMP. ENTERING CONDENSER °F/°C | FREEZE CYCLE | | HARVEST CYCLE | |
|---------------------------------------------|--------------------------|-----------------------------|--------------------------|-----------------------------|
| | HEAD PRESSURE PSIG | SUCTION PRESSURE PSIG | HEAD PRESSURE PSIG | SUCTION PRESSURE PSIG |
| 50/10.0 | 200-250 | 40-22 | 140-170 | 65-80 |
| 70/21.1 | 200-250 | 40-22 | 140-170 | 65-80 |
| 80/26.7 | 230-280 | 42-24 | 150-180 | 70-85 |
| 90/32.2 | 260-310 | 44-24 | 160-190 | 75-90 |
| 100/37.8 | 290-340 | 48-26 | 180-210 | 85-100 |
| 110/43.3 | 320-380 | 50-26 | 190-220 | 90-105 |

* Suction pressure drops gradually throughout freeze cycle

B1800 SERIES WATER-COOLED

These characteristics may vary depending on operating conditions.

CYCLE TIMES

Freeze Time + Harvest Time = Total Cycle Time

| AIR TEMP. AROUND ICE MACHINE °F/°C | FREEZE TIME | | | HARVEST TIME |
|------------------------------------------|-------------------|-----------|-----------|-----------------|
| | WATER TEMP. °F/°C | | | |
| | 50/10.0 | 70/21.1 | 90/32.2 | |
| 70/21.1 | 10.3-11.1 | 11.6-12.5 | 13.7-14.7 | 1-2.5 |
| 80/26.7 | 10.4-11.1 | 11.8-12.6 | 13.8-14.8 | |
| 90/32.2 | 10.4-11.2 | 11.8-12.6 | 13.9-14.9 | |
| 100/37.8 | 10.5-11.3 | 11.9-12.8 | 14.0-15.0 | |

Based on average ice slab weight of 15.5 lb. to 16.5 lb.
Times in minutes

24 HOUR ICE PRODUCTION

| AIR TEMP. AROUND ICE MACHINE °F/°C | WATER TEMP. °F/°C | | |
|---------------------------------------|-------------------|---------|---------|
| | 50/10.0 | 70/21.1 | 90/32.2 |
| 70/21.1 | 1890 | 1700 | 1470 |
| 80/26.7 | 1880 | 1690 | 1460 |
| 90/32.2 | 1870 | 1680 | 1450 |
| 100/37.8 | 1860 | 1670 | 1440 |

Regular cube derate 7%

| CONDENSER WATER CONSUMPTION | 90/32.2 AIR TEMPERATURE | | |
|-----------------------------------|-------------------------|---------|---------|
| | WATER TEMPERATURE °F/°C | | |
| | 50/10.0 | 70/21.1 | 90/32.2 |
| Gal/24 hours | 1200 | 2000 | 4100 |

At 240 PSIG head pressure

OPERATING PRESSURES

| AIR TEMP. AROUND ICE MACHINE °F/°C | FREEZE CYCLE | | HARVEST CYCLE | |
|---------------------------------------------|--------------------------|-----------------------------|--------------------------|-----------------------------|
| | HEAD PRESSURE PSIG | SUCTION PRESSURE PSIG | HEAD PRESSURE PSIG | SUCTION PRESSURE PSIG |
| 50/10.0 | 235-245 | 40-22 | 140-170 | 70-85 |
| 70/21.1 | 235-245 | 40-22 | 140-170 | 70-85 |
| 80/26.7 | 235-245 | 40-22 | 140-170 | 70-85 |
| 90/32.2 | 235-245 | 40-22 | 140-170 | 70-85 |
| 100/37.8 | 240-250 | 42-22 | 150-180 | 70-85 |
| 110/43.3 | 240-260 | 42-22 | 150-180 | 70-85 |

* Suction pressure drops gradually throughout freeze cycle

B1800 SERIES REMOTE

These characteristics may vary depending on operating conditions.

CYCLE TIMES

Freeze Time + Harvest Time = Total Cycle Time

| AIR TEMP. ENTERING CONDENSER °F/°C | FREEZE TIME | | | HARVEST TIME |
|---------------------------------------------------|--------------------------|----------------|----------------|-------------------------|
| | WATER TEMP. °F/°C | | | |
| | 50/10.0 | 70/21.1 | 90/32.2 | |
| -20 to 70/-28.9 to 21.1 | 10.7-11.5 | 12.2-13.1 | 14.1-15.1 | 1-2.5 |
| 80/26.7 | 10.8-11.6 | 12.3-13.2 | 14.3-15.3 | |
| 90/32.2 | 10.9-11.7 | 12.5-13.4 | 14.4-15.5 | |
| 100/37.8 | 12.0-12.8 | 13.8-14.8 | 14.9-16.0 | |
| 110/43.3 | 13.2-14.1 | 15.4-16.5 | 16.8-18.0 | |

Based on average ice slab weight of 15.5 lb. to 16.5 lb.
Times in minutes

24 HOUR ICE PRODUCTION

| AIR TEMP. ENTERING CONDENSER °F/°C | WATER TEMP. °F/°C | | |
|-----------------------------------------------|--------------------------|----------------|----------------|
| | 50/10.0 | 70/21.1 | 90/32.2 |
| -20 to 70/ -28.9 to 21.1 | 1830 | 1630 | 1430 |
| 90/32.2 | 1800 | 1600 | 1400 |
| 100/37.8 | 1660 | 1460 | 1360 |
| 110/43.3 | 1520 | 1320 | 1220 |

Regular cube derate 7%
Rating using BC 1895A condenser, dice or half-dice cubes

OPERATING PRESSURES

| AIR TEMP. ENTERING CONDENSER °F/°C | FREEZE CYCLE | | HARVEST CYCLE | |
|-------------------------------------------------------|-----------------------------------|--------------------------------------|-----------------------------------|--------------------------------------|
| | HEAD PRESSURE PSIG | SUCTION PRESSURE PSIG | HEAD PRESSURE PSIG | SUCTION PRESSURE PSIG |
| -20 to 50/ -28.9 to 10.0 | 220-250 | 42-20 | 120-150 | 70-85 |
| 70/21.1 | 220-250 | 42-20 | 120-150 | 75-90 |
| 80/26.7 | 220-260 | 44-22 | 130-160 | 75-90 |
| 90/32.2 | 250-290 | 44-22 | 140-170 | 75-90 |
| 100/37.8 | 270-320 | 46-24 | 150-180 | 80-95 |
| 110/43.3 | 310-360 | 48-26 | 160-190 | 80-95 |

* Suction pressure drops gradually throughout freeze cycle

REFRIGERANT RECOVERY EVACUATION AND RECHARGING B-MODEL ICE MACHINES

REMOVAL OF REFRIGERANT

Do not purge refrigerant to the atmosphere. Capture refrigerant using recovery equipment by following specific manufacturer's recommendations.

IMPORTANT

Manitowoc Ice, Inc. assumes no responsibility for the use of contaminated refrigerant. Damage resulting from the use of contaminated refrigerant is the sole responsibility of the servicing company.

RECOVERY/EVACUATION AND CHARGING OF SELF-CONTAINED SYSTEMS

REFRIGERANT RECOVERY/EVACUATION

(Refer to illustration - SELF-CONTAINED EVACUATION CONNECTIONS)

IMPORTANT

Replace the liquid line drier before evacuating and recharging. Use only Manitowoc (O.E.M.) liquid line filter drier to prevent voiding warranty.

Refrigerant Recovery/Evacuation of self-contained equipment requires connections at 2 points as follows:

1. Suction side of compressor through suction service valve.
2. Discharge side of compressor through discharge service valve.

Procedures for Self-Contained Recovery/Evacuation

1. Place toggle switch to "OFF" position.
2. Install manifold gauges, charging cylinder/scale, and recovery unit or 2 stage vacuum pump per illustration.
3. Open (backseat) high and low side ice machine service valves, and open high and low side on manifold gauges.

4. Recovery: Operate recovery unit per manufacturer's instructions.

Evacuation prior to recharging: Pull system down to 250 microns. Allow pump to run for 1/2 hour after reaching 250 microns. Turn off vacuum pump after 1/2 hour and ensure pressures do not rise. (Standing vacuum leak check).

NOTE

Recheck for leaks with a halide or electronic leak detector after charging ice machine.

5. Charge the ice machine per the Self-Contained Charging Procedures.

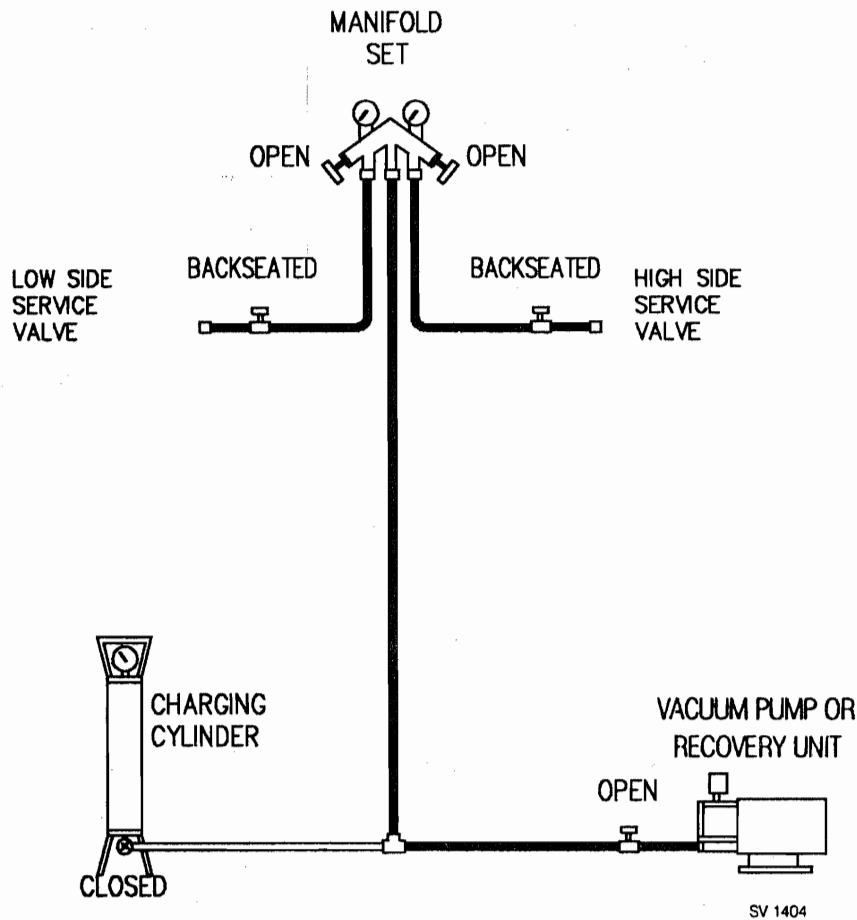

SELF-CONTAINED RECOVERY/EVACUATION CONNECTIONS

SELF-CONTAINED CHARGING PROCEDURES

(Refer to illustration - SELF-CONTAINED CHARGING CONNECTIONS)

IMPORTANT

The charge is critical on all Manitowoc Series ice machines; therefore, use weight or charging cylinder to determine proper charge.

1. Ensure toggle switch is in "OFF" position.
2. Close vacuum pump valve, low side service valve, and low side valve on manifold gauge.
3. Open high side manifold gauge valve, backseat high side service valve.
4. Open charging cylinder and add measured nameplate charge through discharge service valve.
5. Allow system to "settle" for 2 or 3 minutes after charging.
6. Place ice machine toggle switch in "ICE" position, close high side on manifold gauge set, and add remaining vapor charge through suction service valve (if necessary).
7. Ensure all vapor in charging hoses is drawn into the ice machine before disconnecting manifold gauges per the following procedures:

NOTE

Manifold gauges must be properly removed to ensure no refrigerant contamination or loss occurs.

- a. Run ice machine in freeze cycle.
- b. Close high side service valve at ice machine.
- c. Open low side service valve at ice machine.
- d. Open both high and low side valves on manifold gauge set. Refrigerant in lines will be pulled into the low side of system. Allow pressures to equalize with ice machine still in freeze cycle.
- e. Close low side service valve at ice machine.
- f. Remove hoses from ice machine and install caps.

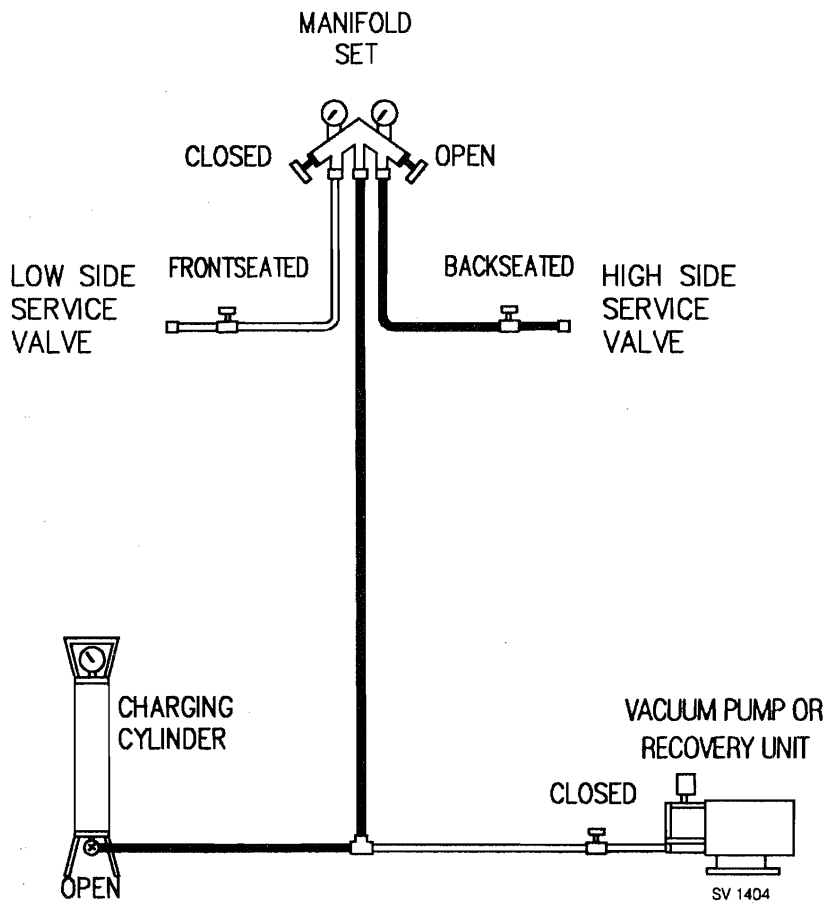

SELF-CONTAINED CHARGING CONNECTIONS

SV 1404

RECOVERY/EVACUATION AND CHARGING OF REMOTE SYSTEMS

REMOTE RECOVERY/EVACUATION CONNECTIONS

Recovery/Evacuation of remote systems requires connections at **4-points** for complete system evacuation as follows:

1. Suction side of compressor through suction service valve.
2. Discharge side of compressor through discharge service valve.
3. Receiver outlet service valve (Evacuates area between check valve in liquid line and pump-down solenoid.)
4. Access (Schraeder) valve on discharge line quick connect fitting on outside of compressor/evaporator compartment. This connection is necessary to evacuate the condenser. Without this connection, the magnetic check valves would close upon the pressure drop produced by evacuation prohibiting complete condenser evacuation.

NOTE

Manitowoc recommends using an access valve core removal and installation tool on the discharge line quick connect fitting. The tool permits removal of the access valve core for faster evacuation and charging without removing the manifold gauge hose.

REMOTE SYSTEM REFRIGERANT RECOVERY/EVACUATION PROCEDURES:

1. Place toggle switch in "OFF" position.
2. Install manifold gauges, scale, and recovery unit or 2-stage vacuum pump per illustration, 4-Point Evacuation Connections.
3. Open (backseat) high and low side ice machine service valves, position receiver service valve 1/2 open, and open high and low side on manifold gauge set.

- Recovery: Operate recovery unit per manufacturer's instructions.

Evacuation prior to recharging: Pull system down to 250 microns. Allow to run for 1 hour after reaching 250 microns. Turn off vacuum pump, ensure pressures do not rise (standing vacuum leak-check).

NOTE

Recheck for leaks with a halide or electronic leak detector after charging ice machine.

- Charge the ice machine per the following charging procedures.

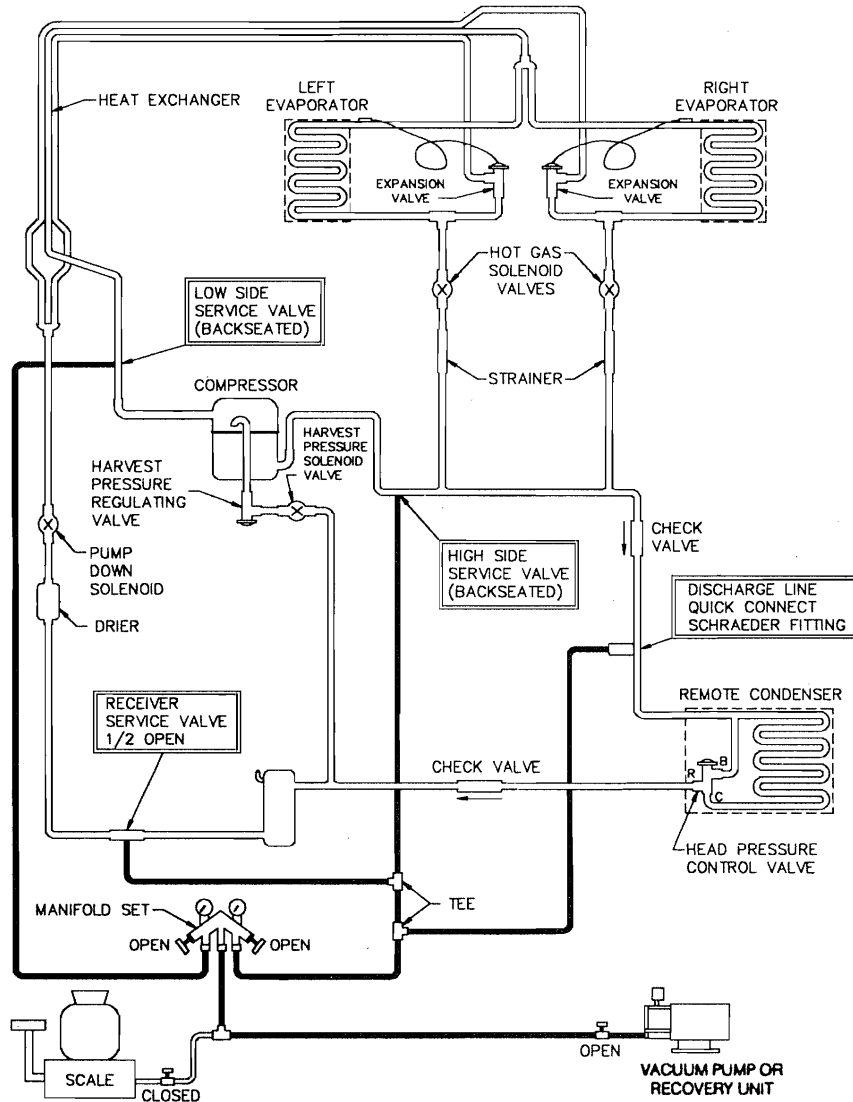

REMOTE RECOVERY/EVACUATION CONNECTIONS

REMOTE CHARGING PROCEDURES

(Refer to illustration - REMOTE CHARGING CONNECTIONS)

1. Ensure toggle switch is in the "OFF" position.
2. Close vacuum pump valve, frontseat (close) low side and high side service valves, close low side valve on manifold gauge set.
3. Add measured nameplate charge from charging scale through high side of manifold gauge set into system high side (receiver outlet valve and discharge lines quick-connect fitting).
4. If high side does not take entire charge, close high side on manifold gauge set, backseat (open) low side service valve, and receiver outlet service valve. Start ice machine and add remaining charge through low side in vapor form until the machine is fully charged.
5. Ensure all vapor in charging hoses is drawn into the machine before disconnecting manifold gauges as described in Step 7 of "Self Contained Charging Procedures".

NOTE

Backseat receiver outlet service valve after charging is complete and before operating the ice machine. If access valve core removal and installation tool is used on the discharge line quick-connect fitting, reinstall Schraeder valve core before disconnecting access tool and hose.

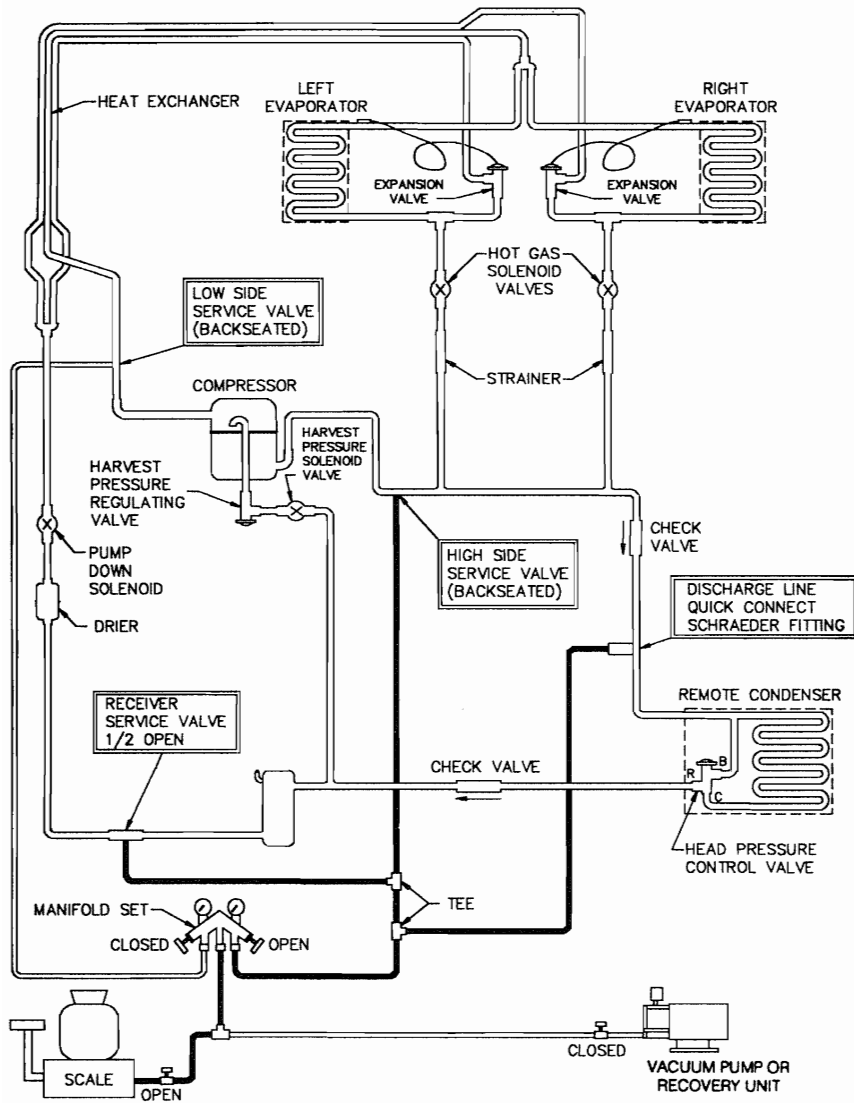

SV 1404

REMOTE CHARGING CONNECTIONS

REFRIGERANT CHARGE

IMPORTANT

*Refer to machine serial tag to
verify system charge.*

B150 Series

| | | |
|--------------|--------|------------------------|
| Air-Cooled | 14 oz. | SUVA [®] HP81 |
| Water-Cooled | 10 oz. | SUVA [®] HP81 |

B200 Series

| | | |
|--------------|--------|------------------------|
| Air-Cooled | 20 oz. | SUVA [®] HP81 |
| Water-Cooled | 12 oz. | SUVA [®] HP81 |

B250 Series

| | | |
|--------------|--------|------------------------|
| Air-Cooled | 18 oz. | SUVA [®] HP81 |
| Water-Cooled | 14 oz. | SUVA [®] HP81 |

B320 Series

| | | |
|--------------|--------|------------------------|
| Air-Cooled | 20 oz. | SUVA [®] HP81 |
| Water-Cooled | 15 oz. | SUVA [®] HP81 |

B420/B450 Series

| | | |
|---------------|--------|------------------------|
| Air-Cooled | 26 oz. | SUVA [®] HP81 |
| Water-Cooled | 20 oz. | SUVA [®] HP81 |
| Remote (B450) | 8 lb. | SUVA [®] HP81 |

B600 Series

| | | |
|--------------|--------|------------------------|
| Air-Cooled | 32 oz. | SUVA [®] HP81 |
| Water-Cooled | 24 oz. | SUVA [®] HP81 |
| Remote | 10 lb. | SUVA [®] HP81 |

B800 Series

| | | |
|--------------|--------|------------------------|
| Air-Cooled | 35 oz. | SUVA [®] HP81 |
| Water-Cooled | 32 oz. | SUVA [®] HP81 |
| Remote | 10 lb. | SUVA [®] HP81 |

B1000 Series

| | | |
|--------------|--------|------------------------|
| Air-Cooled | 38 oz. | SUVA [®] HP81 |
| Water-Cooled | 34 oz. | SUVA [®] HP81 |
| Remote | 10 lb. | SUVA [®] HP81 |

B1300 Series

| | | |
|--------------|---------|------------------------|
| Air-Cooled | 54 oz. | SUVA [®] HP81 |
| Water-Cooled | 38 oz. | SUVA [®] HP81 |
| Remote | 14 lb.. | SUVA [®] HP81 |

B1800 Series

| | | |
|--------------|--------|------------------------|
| Air-Cooled | 68 oz. | SUVA [®] HP81 |
| Water-Cooled | 46 oz. | SUVA [®] HP81 |
| Remote | 14 lb. | SUVA [®] HP81 |

DuPont SUVA[®] HP81 is R402B

CHARGING SUVA®HP81 (R402B)

UTILIZING R-502 SCALE ON CHARGING CYLINDERS

1. Charge cylinder with HP81 (R402B).
2. Read pressure indicated on the charging cylinder gauge.
3. Using the R-502 scale, rotate the charging cylinder to the pressure listed in the chart.

| Pressure Reading on Gauge | Rotate Dial to R-502 Scale Listed Below |
|---------------------------|-----------------------------------------------|
| 75 to 81 | 110 |
| 82 to 90 | 120 |
| 91 to 100 | 130 |
| 101 to 109 | 140 |
| 110 to 119 | 150 |
| 120 to 129 | 160 |
| 130 to 138 | 170 |
| 139 to 148 | 180 |
| 149 to 159 | 190 |
| 160 to 169 | 200 |
| 170 to 179 | 210 |
| 180 to 190 | 220 |
| 191 to 200 | 230 |
| 201 to 211 | 240 |
| 212 to 220 | 250 |

REPLACING PRESSURE CONTROLS WITHOUT REMOVING REFRIGERANT CHARGE

The following procedure prevents opening of the refrigeration system and reduces repair time and cost. Use this procedure when one of the following components requires replacing and the refrigeration system is leak free and operational.

IMPORTANT: This is a required in-warranty repair procedure.

- Fan cycle control (air-cooled only)
- Water regulating valve (water-cooled only)
- High pressure cut-out control
- Low pressure cut-out control (remotes only)
- High side service valve
- Low side service valve

INSTRUCTIONS:

1. Disconnect power to ice machine. **Follow all manufacturer's instructions supplied with "pinch-off" tool.**
2. Position pinch-off tool around tubing as far away from pressure control as feasible. Clamp down on tubing until pinch-off is complete. Figure A.



WARNING

Do not unsolder a defective component. "Cut" it out of the system. Do not remove pinch-off tool until the new component is securely soldered in place.

3. Leaving pinch-off tool securely in place, unsolder or cut tubing of defective component with a small tubing cutter.
4. Install new component. Allow solder joint to cool.
5. Remove pinch-off tool.
6. To re-round tubing, position wide angle of pinched tubing into corresponding diameter hole of pinch-off tool. Tighten wing nuts until block is tight and tubing is rounded. Figure B.

NOTE:

Pressure controls will operate normally once "pinched off" tubing is re-rounded. (Tubing may not re-round 100%.)

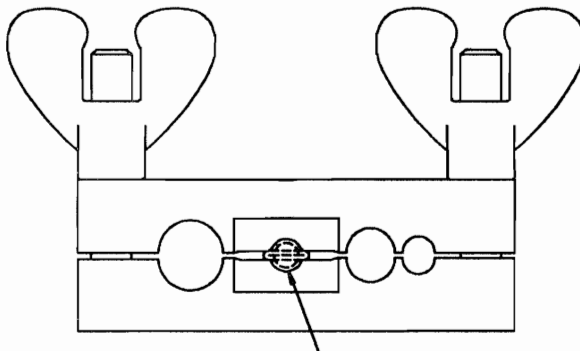
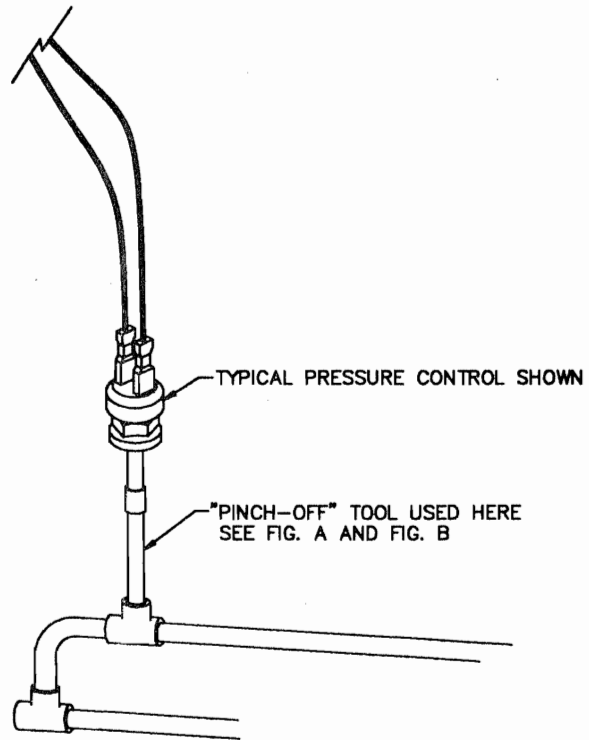

FIG. A - "PINCHING OFF" TUBING

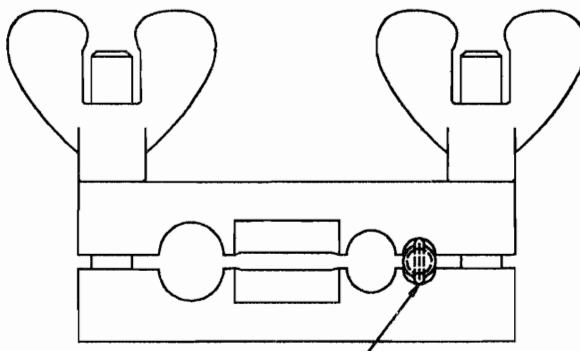

FIG. B - RE-ROUNDING TUBING

SV 1406
9/93

SYSTEM CONTAMINATION

GENERAL

It is important to read and understand the following text regarding system contamination. The purpose is to describe the basic requirements for restoring contaminated systems to reliable service.

IMPORTANT

Manitowoc Ice, Inc. assumes no responsibility for use of contaminated refrigerant. Damage resulting from the use of contaminated recovered or recycled refrigerant is the sole responsibility of the servicing company.

DETERMINING SEVERITY OF CONTAMINATION AND CLEAN-UP PROCEDURES

System contamination is generally caused by the introduction of either moisture or residue from compressor burnout into the refrigeration system.

Inspection of the refrigerant is usually the first indication of contaminants in the system. If obvious moisture or an acrid odor indicating burnout is present in the refrigerant, steps must be taken to determine the *severity* of contamination as well as the required clean-up procedure.

If visible moisture or an acrid odor is detected, or if contamination *is suspected*, the use of a Total Test Kit from Totaline or similar diagnostic tool is recommended. These devices read refrigerant, therefore eliminating the need for an initial oil sample for testing.

If a refrigerant test kit indicates harmful levels of contamination, or if the kit is not available, then inspect the compressor oil as follows.

1. Remove refrigerant charge from ice machine.
2. Remove compressor from the system.
3. Check odor and condition (appearance) of the oil.
4. Inspect open suction and discharge lines at compressor for burnout deposits.
5. Perform an acid oil test if contamination signs are not evident per the above procedure to ensure no harmful contamination is present.

The following chart lists findings and matches them with required clean-up procedure. Use this chart for determining type of clean-up required.

CONTAMINATION/CLEAN-UP CHART

| Symptoms/Findings | Required Clean-Up Procedure |
|------------------------------------------------------------------------------------------------------------------------------------------------------------------------------------------------------------------------------------------------------------------------------------------------------------------------------------------------------------------------------------|----------------------------------------------|
| No symptoms or suspicion of contamination | Normal evacuation and recharging procedures. |
| Moisture/Air Contamination (one or more of the following conditions will exist) <ul style="list-style-type: none"> - Refrigeration system open to atmosphere for prolonged periods - Refrigeration test kit and/or acid oil test shows contamination - Leak in water-cooled condenser - Oil appears muddy, or visible moisture in oil | Mild contamination clean-up procedures. |
| Mild Compressor Burnout <ul style="list-style-type: none"> - Oil appears clean with acrid odor and/or - Refrigeration test kit or acid oil test shows harmful acid content - No burnout deposits in open compressor lines | Mild contamination clean-up procedures. |
| Severe Compressor Burnout <ul style="list-style-type: none"> - Oil discolored and acidic with acrid odor, burnout deposits in compressor, discharge and suction lines and other components | Severe contamination clean-up procedures. |

MILD SYSTEM CONTAMINATION CLEAN-UP PROCEDURES

1. Replace failed components if applicable. If compressor checks good, change oil in compressor.
2. Replace liquid line drier.
3. Follow normal evacuation procedure except replace the evacuation step with the following:

NOTE

If contamination is from moisture, the use of heat lamps or heaters is recommended during evacuation. Place heat lamps at the compressor, condenser, and at the evaporator prior to evacuation. (Ensure heat lamps are not positioned too close to plastic components such as evaporator extrusions, water trough, etc., as they could melt, warp, etc.)

IMPORTANT

Dry nitrogen is recommended for this procedure to prevent C.F.C. release into the atmosphere.

- a. Pull vacuum to 1000 microns. Break vacuum with dry nitrogen and sweep system. Pressurize to a minimum of 5 psi.
 - b. Pull vacuum to 500 microns. Break vacuum with dry nitrogen and sweep system. Pressurize to a minimum of 5 psi.
 - c. Change vacuum pump oil. Pull system down to 250 microns. When 250 microns have been achieved, allow vacuum pump to run for 1/2 hour on self-contained models, 1 hour for remotes. A standing vacuum test may be performed at this time as a preliminary means of leak checking; however, the use of an electronic leak detector after the system has been charged is recommended.
4. Charge system with proper refrigerant to nameplate charge.
 5. Operate ice machine.

SEVERE SYSTEM CONTAMINATION CLEAN-UP PROCEDURES

1. Remove refrigerant charge.
2. Remove compressor.
3. Disassemble hot gas solenoid valve. If burnout deposits are found inside valve, install rebuild kit and replace TXV and harvest pressure regulating valve.
4. Check discharge and suction lines at compressor for burnout deposits. Wipe out as necessary.
5. Sweep through open system with dry nitrogen.

NOTE

Refrigerant sweeps are not recommended, as they release C.F.C.'s into the atmosphere.

6. Installation Procedures:
 - a. Install new compressor and start components.
 - b. Install an adequately sized suction line filter-drier with acid/moisture removal capability and inlet/outlet access valves. Place the filter-drier as close to the compressor as practical.
 - c. Replace liquid line filter-drier.
7. Follow normal evacuation procedures except replace the evacuation step with the following:

IMPORTANT

Dry nitrogen is recommended for this procedure to prevent C.F.C. release into the atmosphere.

- a. Pull vacuum to 1000 microns. Break vacuum with dry nitrogen and sweep system. Pressurize to a minimum of 5 psi.
- b. Change vacuum pump oil. Pull vacuum to 500 microns. Break vacuum with dry nitrogen and sweep system. Pressurize to a minimum of 5 psi.
- c. Change vacuum pump oil. Pull system down to 250 microns. When 250 microns have been achieved, allow vacuum pump to run for 1/2 hour for self-con-

tained models, 1 hour for remotes. A standing vacuum test may be performed at this time as a preliminary means of leak checking; however, the use of an electronic leak detector after the system has been charged is recommended.

8. Charge system with proper refrigerant to nameplate charge.
9. Operate ice machine.
 - a. Check pressure drop across the suction line filter-drier after 1 hour running time. If pressure drop is not excessive (up to 1 psi differential), the filter-drier should be adequate for complete clean-up. Proceed to step 10.
 - b. If pressure drop is greater than 1 psi after 1 hour run time, change the suction line filter-drier and liquid line drier. Repeat until ice machine will run 1 hour without pressure drop.
10. Remove suction line filter-drier after 48-72 hours run time. Change liquid line drier and follow normal evacuation procedures.

REFRIGERANT DEFINITIONS

RECOVERY

To remove refrigerant in any condition from a system and store it in an external container without necessarily testing or processing it in any way.

RECYCLING

To clean refrigerant for reuse by oil separation and single or multiple passes through devices, such as replaceable core filter-driers, which reduce moisture, acidity, and particulate matter. This term usually applies to procedures implemented at the field job site or at a local service shop.

RECLAIM

To reprocess refrigerant to new product specifications by means which may include distillation. Will require chemical analysis of the refrigerant to determine that appropriate product specifications are met. This term usually implies the use of processes or procedures available only at a reprocessing or manufacturing facility.

NOTES REGARDING RECLAIM:

"New product specifications" currently means ARI Standard 700 (latest edition). Note that chemical analysis is required to assure that this standard is met.

Chemical analysis is the key requirement in the definition of "Reclaim". Regardless of the purity levels reached by a reprocessing method, the refrigerant is not "reclaimed" unless it has been chemically analyzed and meets ARI Standard 700 (latest edition).

MANITOWOC REFRIGERANT USE POLICY

Manitowoc recognizes and supports the need for proper handling, reuse of, or disposal of, CFC and HCFC refrigerants. Manitowoc service procedures require recapturing of refrigerants, not venting to atmosphere.

It's not necessary, in or out of warranty, to reduce or compromise the quality and reliability of your customers' products to achieve this.

Manitowoc **approves** the use of:

1. *New refrigerant* (original name plate type).
2. *Reclaimed refrigerant* (original name plate type) - must meet A.R.I. Standard 700 (latest edition) specifications.
3. *Recovered or recycled refrigerant* reuse:
 - A. Refrigerant must be recovered and/or recycled in accordance with latest local, state, and federal laws.
 - B. Refrigerant must be recovered from the same Manitowoc product which it will be reused in. Recovered or recycled refrigerant reuse from other products is not approved.
 - C. Recycling equipment must be certified to A.R.I. Standard 740 (latest edition) and be maintained to consistently meet this standard.
 - D. Refrigerant recovered and reused must come from a "contaminant free" system. "Contaminant free" decision is influenced by type of previous failures, was the system cleaned, evacuated, and recharged properly after previous failures, and the present failure did not contaminate the system. Compressor motor burnouts and systems not serviced properly in the past (an acid test can help determine system condition) prevent reuse of recovered refrigerant.

If you are not sure of the contaminant level, refer to service manual for "Determining Severity of System Contamination and Proper Clean-Up Procedures".

- E. Whether recovering and reusing, or recycling, the **service person is responsible** to assure the refrigerant is not mixed with air, other refrigerants, etc., and is "contaminant free" prior to reuse.

IMPORTANT

Manitowoc Ice, Inc. assumes no responsibility for use of contaminated refrigerant. Damage resulting from the use of contaminated, recovered, or recycled refrigerant is the sole responsibility of the servicing company.

4. *"Substitute" or "Alternative" refrigerant:*
 - A. Must use only Manitowoc approved alternative refrigerants.
 - B. Must follow Manitowoc published conversion procedures.

SUVA[®] HP81 (R402B) QUESTIONS AND ANSWERS

IS SUVA[®] HP81 FLAMMABLE? No - it is U.L. and ASHRAE classified as "practically non-flammable". The same rating is given to R-22 and R-502. SUVA[®] HP81's ignition temperature of 641°C is actually less flammable than R-22 (632°C)!

IS SUVA[®] HP81 TOXIC? The EPA exposure limit rating for SUVA[®] HP81 is 1000 ppm, the highest rating given by the EPA for a refrigerant. SUVA[®] HP81 carries the same rating as R-12, R-22, and R-502.

IS A SPECIAL COMPRESSOR OIL REQUIRED WITH SUVA[®] HP81? No - Manitowoc products use standard mineral type compressor oil with SUVA[®] HP81. (The same as R-22 and R-502.)

HOW DO I LEAK CHECK A SYSTEM CONTAINING SUVA[®] HP81? Standard soap bubbles, halide torches, and standard electronic type leak detectors work.

DO I HAVE TO RECOVER SUVA[®] HP81? Yes - like other refrigerants, government regulations require recovering SUVA[®] HP81.

WILL SUVA[®] HP81 SEPARATE IF I HAVE A LEAK IN THE SYSTEM? No - like R-502, the degree of separation is too small to detect.

HOW DO I CHARGE A SYSTEM WITH SUVA[®] HP81? The same as R-502. It is recommended to charge liquid refrigerant only into the high side of the system.

CAN I PUT SUVA[®] HP81 INTO R-502 G-MODEL ICE MACHINES? Yes - SUVA[®] HP81 refrigerant can be used as an alternative replacement refrigerant in Manitowoc G-Model (R-502) ice machines. **Contact Manitowoc distributor for field conversion kit 76-2559-3.**

WHERE CAN I PURCHASE SUVA[®] HP81? DuPont refrigerants, including SUVA products, are available through more than 1,300 authorized distributors in the U.S.

IS SPECIAL EQUIPMENT REQUIRED TO SERVICE SUVA[®] HP81? No - standard refrigeration gauges, hoses, recovery systems, driers, vacuum pumps, etc. are compatible with SUVA[®] HP81.

Factory School

- Improve Your Service Techniques.
- 4 Days of Intensive Training on Manitowoc Ice Machines, Dispensers, and Reach-Ins.
- Contact Your Distributor For Dates and Further Information.

MANITOWOC ICE, INC.
2110 South 26th Street P.O. Box 1720
Manitowoc WI. 54221-1720 USA
Phone: 920-682-0161 Fax: 920-683-7585
Website – www.manitowocice.com