

ICE MAKER
SERVICE MANUAL

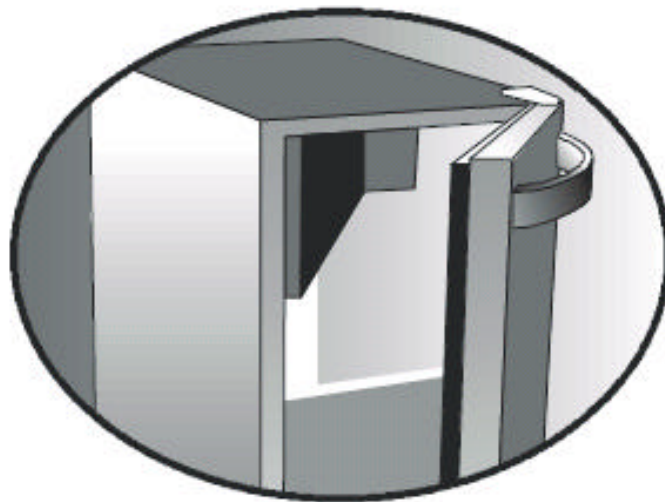

 **Electrolux**

5995436457 5/2005

SAFE SERVICING PRACTICES - ALL APPLIANCES

To avoid personal injury and/or property damage, it is important that **Safe Servicing Practices** be observed. The following are some limited examples of safe practices:

1. **DO NOT** attempt a product repair if you have any doubts as to your ability to complete it in a safe and satisfactory manner.
2. Before servicing or moving an appliance:
 - Remove the power cord from the electrical outlet, trip the circuit breaker to the OFF position, or remove the fuse.
 - Turn off the gas supply and allow any residual gas to dissipate for 10 to 20 minutes.
3. Never interfere with the proper operation of any safety device.
4. **USE ONLY REPLACEMENT PARTS CATALOGED FOR THIS APPLIANCE. SUBSTITUTIONS MAY DEFEAT COMPLIANCE WITH SAFETY STANDARDS SET FOR HOME APPLIANCES.**
5. **GROUNDING:** The standard color coding for safety ground wires is **GREEN**, or **GREEN** with **YELLOW STRIPES**. Ground leads are not to be used as current carrying conductors. It is **EXTREMELY** important that the service technician reestablish all safety grounds prior to completion of service. Failure to do so will create a hazard.
6. Prior to returning the product to service, ensure that:
 - All electrical connections are correct and secure
 - All electrical leads are properly dressed and secured away from sharp edges, high-temperature components, and moving parts
 - All non-insulated electrical terminals, connectors, heaters, etc. are adequately spaced away from all metal parts and panels
 - All safety grounds (both internal and external) are correctly and securely connected
 - All panels are properly and securely reassembled

ATTENTION!!!

This service manual is intended for use by persons having electrical and mechanical training and a level of knowledge of these subjects generally considered acceptable in the appliance repair trade. Electrolux Major Appliances cannot be responsible, nor assume any liability, for injury or damage of any kind arising from the use of this manual.

Safe Servicing Practices	2
Quick Reference Sheet	4
Owner's Guide and Parts Information	4
Contact Information	4
General information	5
Safety Precautions	5
Door Adjustment	5
Ice Production Rates	7
Customer Questions	7
Sequence of Operation	8
Automatic Shut-off	8
System and Time Chart	9
Leveling and Installation Requirements	10
Leveling the Unit	10
Installation Requirements	10
Gravity Drain Installation	11
Connecting a Drain Pump	12
Automatic Clean Cycle Instructions	12
Interior Storage Bin Cleaning	13
Sample Wiring Diagram	14
Compressor/Electrical Specifications	15
Compressor Pins	15
Specifications	15
Thermister	16
Check Light on Control Board	16
Low Side Pressure Changes	17
Ice Thickness Adjustment	18
Differences are as follows	18
Adjusting Ice Cube Thickness	19
Refrigeration System Diagnosis Guide	21
Troubleshooting	22
Unit does Not Operate (with drain pump; light on control board is not illuminated)	22
Unit Does Not Operate (without drain pump; light on control board is not illuminated)	22
Unit Does Not Operate And light On Control Board Is Illuminated	22
No Ice Production	22
Low Ice Production	22
Will Not Eject Ice (water frozen)	23
Ice Is Slow To Release From Evaporator	23
Will Not Fill With Water	23
Continuous Ice Production	23
Low (Or No) Ice Production	24
Poor Ice Quality (soft or unclear cubes)	24
Unit Not Freezing (compressor and fan operating)	24
Unit Produces Shallow Or Incomplete Cubes Or The Ice Fill Pattern On The Grid Is Incomplete	25
Not Freezing Compressor Not Running / Fan Operating	25
Not Freezing (compressor and fan not operating)	25
If the Unit Has A Drain Pump	25
Water Leak Under Unit	26
Water In Ice Bin	26
Water Will Not Stop Filling	26
Unit noisy	26

QUICK REFERENCE SHEET

1. Owner's guide and parts information may be viewed or downloaded at: **www.electroluxusa.com**
-

2. Contact information:
- | | | |
|---------|----------------------------------|----------------|
| Orders. | EHP Direct South: | 1-800-845-4555 |
| | EHP Direct Northeast | 1-800-611-4057 |
| | Fax | 1-800-611-4058 |
| | EHP Direct North, Central & West | 1-800-345-2566 |
-

Canada Service, Warranty, General Questions.	Monday - Friday 8:00 AM - 5:00 EST 1-800-265-8352
--	---

U.S.A. Service, Warranty, General Questions.	Monday - Friday 8:00 AM - 5:00 EST 1-877-4Electrolux (435-3287) Electrolux ICON brands
--	---

Damage Claims.	1-800-456-4669 (option 3, then option 2)
----------------	--

Parts Orders.	1-800-320-0859
---------------	----------------

Mailing Address.	Electrolux Major Appliances P.O. Box 212378 Martinez, GA. 30917
------------------	---

GENERAL INFORMATION

Safety Precautions

Do not attempt to service or repair the unit until you have read the entire procedure. Safety items throughout this manual are labeled with Danger, Warning or Caution.



Risk of child entrapment. Before you throw away an old refrigerator or freezer: Take off the doors, leave shelves in place so that children may not easily climb inside



- Never attempt to repair or perform maintenance on the unit until the electricity has been disconnected.
- Altering, cutting of power cord, removal of power cord, removal of power plug, or direct wiring can cause serious injury, fire and/or loss of property and/or life and will void the warranty.

CAUTION

- Do not lift unit by door handle.
- Never use an ice pick or other sharp instrument to help speed up defrosting. These instruments can puncture the inner lining or damage the cooling unit.
- Failure to clean the condenser every three months can cause the unit to malfunction. This could void the warranty.
- Never install the unit behind closed doors. Be sure front grille is free of obstruction. Obstructing free air flow can cause the unit to malfunction, and may void the warranty.

Door Adjustment

All model doors are aligned at the factory before shipment. Occasional readjustment may be necessary, especially if an Overlay Panel is installed. The following procedure will correct for up to 1/4" alignment.

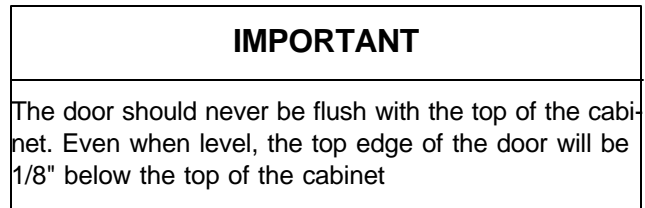

To adjust door:

1. Compare the top edge of the door (opposite the hinges) to the top edge of the cabinet and note the type (up or down) of adjustment needed.
2. Remove the top hinge pivot pin with a 7/64" hex wrench and lift door off bottom hinge pin.

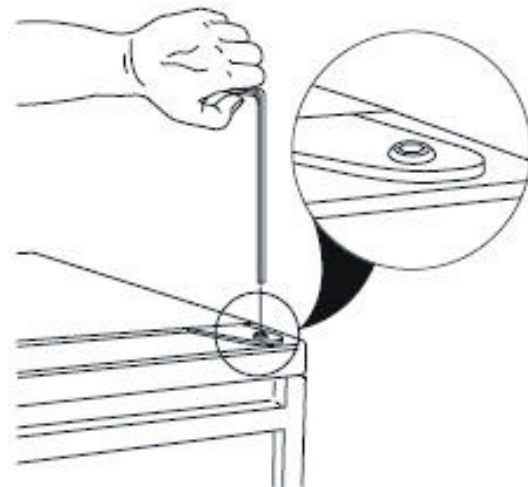

Be careful not to lose door closer inserts.

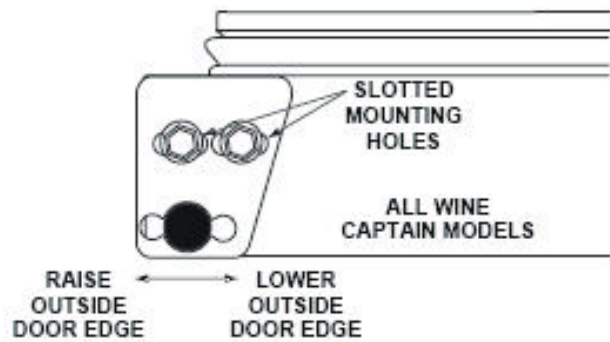
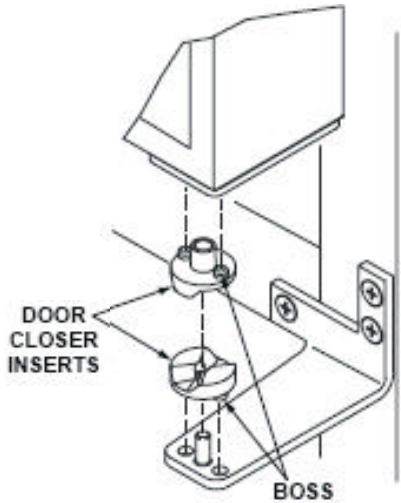

- After adjustment is complete, remove the door closers from the bottom hinge, clean thoroughly and apply petroleum jelly to the mating surfaces of the closers. Be sure that bosses on closers align with holes in hinge and hinge plate. Mount door and install top hinge pivot pin.

Note: The hinge plate on some models do not have the holes slotted for adjustment. New hinge plates are available from Electrolux Parts.

- With door upside-down, inspect the bottom hinge plate mounting holes.
 - If your plate has slotted mounting holes, loosen but do not remove the two hinge plate screws.
 - If your plate does not have slotted mounting holes, remove the old plate and install the new plate with the notch to the inside of the door.
- If door edge opposite the hinges needs to move up, move plate toward outside of door. If door edge needs to move down, move plate toward inside of door. Repeat until top edge of door is parallel with top of cabinet and tighten screws securely.

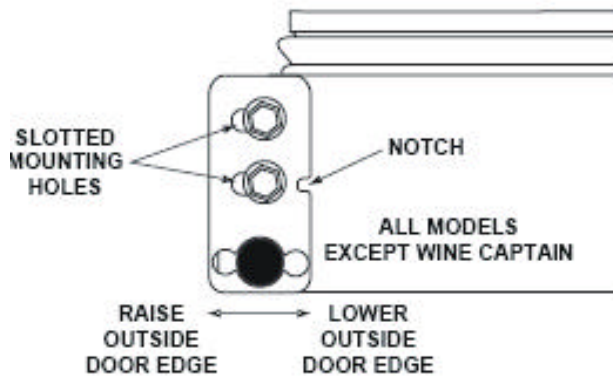
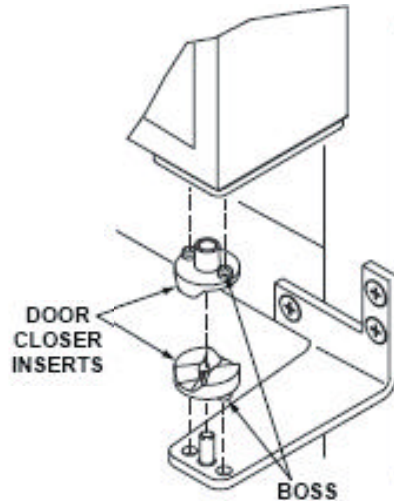

Ice Production Rates

Ambient Temp/Water Temp degrees F	Approximate Ice Production (lbs/day)
50/50	60
60/50	60
70/50	58
80/50	54
90/70	47
100/70	40

NOTE: These characteristics will vary depending on operating conditions, condenser cleanliness, installation, and application.

Customer Questions

- | | |
|--|---|
| <p>1. No ice or not enough ice!</p> | <p>1. Factory specifications for ice production 60 lbs., bucket size 35 lbs.</p> |
| <p>2. Wet icecubes</p> | <p>2. The storage bin that holds the ice is not refrigerated. The cubes in the bin are slowly melting down. The bin will maintain a temperature of 32 to 34 degrees.</p> |
| <p>3. The floor is very warm in front of the icemaker.</p> | <p>3. The unit is designed for a built-in application, so the warm air will discharge out the bottom of the unit below the door. There is a safety feature built into the control board that will shut the unit down if the warm air cannot be dissipated.</p> |
| <p>4. No ice, water pours into the trough and down into the drain.</p> | <p>4. The standpipe needs to be inserted into the drain hole of the water trough to maintain the proper level of water inside the trough.</p> |
| <p>5. When the unit on is turned on, all I get is water fill.</p> | <p>5. Check to be sure switch is in ice mode.</p> <p>Once the unit is turned on, there will be a three minute water fill. This will assure that a fresh batch of water has filled the trough. If water flows more than three minutes a service call will be required.</p> |
| <p>6. My ice does not come out in a perfect cube shape</p> | <p>6. The manner in which the ice is made causes a small hole or "dimple" to appear on the front or top of the cube. Increasing or decreasing the time of the freeze cycle will adjust the size of the dimple. A service company will need to make this adjustment.</p> |

Customer Questions

7. The cubes do not fall into bin as individual cubes.
7. Normal - You can use the scoop to break apart.
8. Not enough ice is stored in the bin.
8. Check the level of the unit.

Sequence of Operation

On initial start-up or restart, closing of bin thermostat, the toggle switch is in the ICE position:

1. The water solenoid valve and hot gas solenoid valve are opened (energized) for 180 seconds (three minutes). This ensures the ice making cycle starts with fresh water, and the refrigerant pressures are equalized prior to compressor start-up.
2. The compressor starts 175 seconds after the hot gas solenoid valve and water solenoid valves are opened.
3. The water pump and condenser fan motor are energized. The hot gas solenoid valve and water solenoid valves are de-energized (closed) five seconds after the compressor starts. The unit is now in the freeze cycle.
4. As the water pump circulates the water, an even flow is directed across the evaporator and into each cube cell, where it freezes. As the water freezes, gravity causes any sediment to drop into the water trough and not becoming imbedded in the ice. This gives a clearer cube with low mineral content.
5. The control system automatically determines the length of the freeze cycle by monitoring the temperature of the refrigeration system "high side" using a thermistor.
6. One minute prior to finishing the determined freeze cycle, the control determines the length of the harvest cycle by again monitoring the temperature at the thermistor.
7. When the freeze cycle is completed, the control de-energizes the water pump and the condenser fan motor. The compressor remains running during the harvest cycle. The control then energizes the hot gas solenoid valve and water solenoid valve for the duration of the harvest cycle. The hot refrigerant gas warms the evaporator causing the cubes to slide, as a sheet, off the evaporator and into the storage bin. At the same time, the water trough is being purged with fresh water.

8. At the conclusion of the harvest cycle, the machine returns to a new freeze cycle. The compressor continues to run. The water pump and condenser fan motor are energized. The hot gas solenoid valve and water solenoid valves are de-energized (closed).

Automatic Shut-off

The ice machine shut-off is controlled by the level of ice in the ice storage bin. When the bin is full, ice contacts the bin thermostat bulb holder, which senses the cool temperatures, then opens which stops the ice machine. The ice machine will remain off until the ice cubes no longer contact the bin thermostat bulb holder. This causes the bin thermostat to warm and close, restarting the ice machine.

When the ice machine restarts, it returns to the start-up sequence (steps 1, 2, and 3).

System and Time Chart

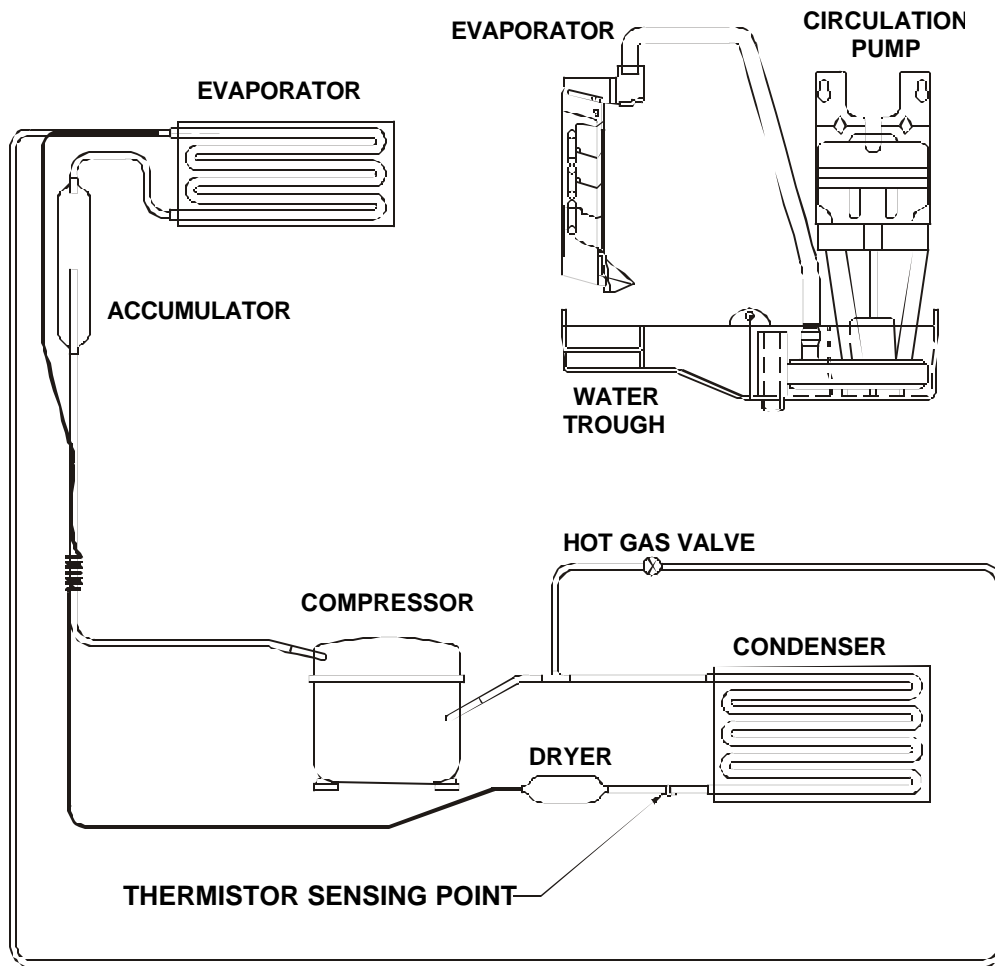

CYCLE DESCRIPTION	INITIAL START UP			FREEZE CYCLE												HARVEST CYCLE				
	1	2	3	4	5	6	7	8	9	10	11	12	13	14	15	16	17	18	19	
TIME (MINUTES)																				
WATER FILL VALVE	■	■	■															■	■	■
HOT GAS VALVE	■	■	■															■	■	■
WATER CIRCULATION PUMP				■	■	■	■	■	■	■	■	■	■	■	■	■	■			
COMPRESSOR				■	■	■	■	■	■	■	■	■	■	■	■	■	■			
CONDENSER FAN				■	■	■	■	■	■	■	■	■	■	■	■	■	■			

ENERGIZED
 NON-ENERGIZED

NOTE: THE FREEZE/HARVEST CYCLE TIMES WILL VARY DUE TO OPERATING CONDITIONS.

Leveling and Installation Requirements

It is extremely important that the unit is level.

If it is not level, the ice mold will not fill evenly. This can cause a reduction in ice rate, uneven sized cubes or water spilling into the storage area which will cause the ice in the bin to melt prematurely.

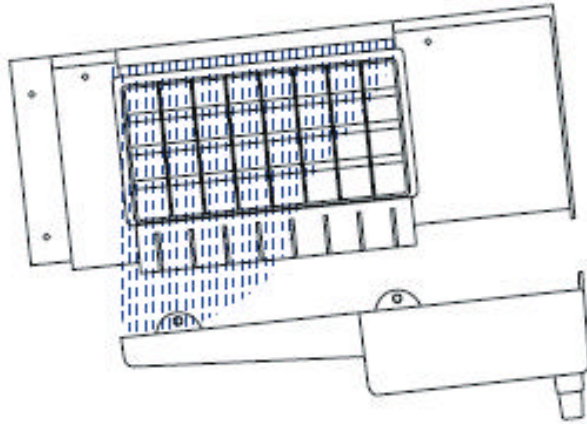

Remember the floor surrounding a drain has a tendency to slope towards the drain.

Leveling the Unit

1. Use a level to check the ice maker from front to back and from side to side.

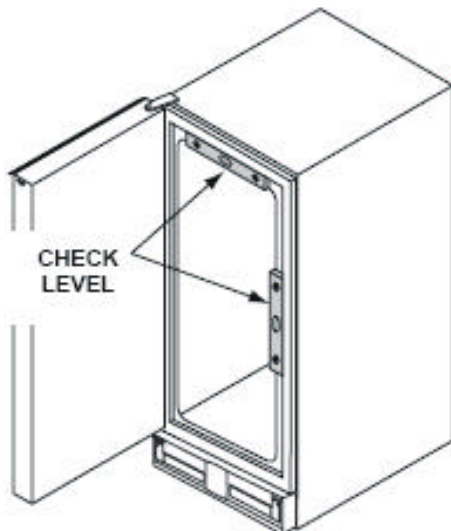

2. If the ice maker is not level, adjust the feet on the corners of the unit as necessary.

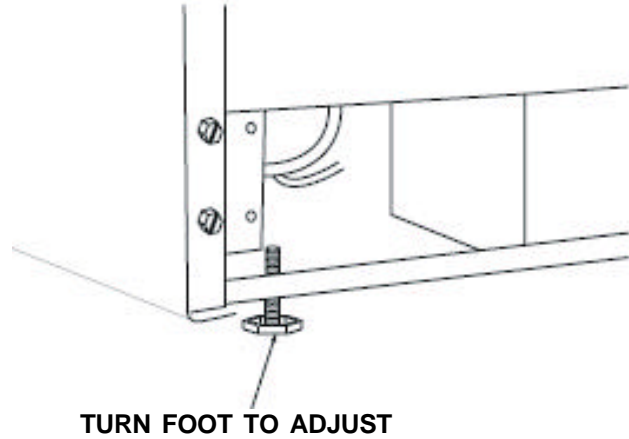

3. Check after each adjustment and repeat the previous steps as necessary until the unit is level.

Installation Requirements

- The unit may be built into a cabinet. There is no minimum clearance requirement for the top, left or right sides of the unit.
- The location must allow enough clearance for water, drain, and electrical connections in the rear of the unit.
- The location must not obstruct air flow to the front of the unit.

Gravity Drain Installation

Caution: Plumbing installation must observe all state and local codes.

These guidelines must be followed when installing drain lines to prevent water from flowing back into the ice maker storage bin and potentially flowing onto the floor causing water damage:

- Drain lines and fittings must have a 5/8" inside diameter.
- Drain lines must have a 1" drop per 48" of run (1/4" per foot) and must not create traps.
- The floor drain must be large enough to accommodate drainage from all drains.
- Insulate the bin drain line to prevent condensation.

Be sure to follow these guidelines to prevent water backing up into the storage bin.

Below are examples of gravity drain line installations. If a trap is in the drain line, the drain line must be vented to assure proper draining. Without the vent, water will backup until enough pressure builds up to force the water past the trap. Water may backup into the ice bin before the amount of pressure needed is achieved. Water in the storage bin will cause the ice in the bin to melt prematurely.

The customer's complaint will be slow ice production. The ice that has been made is melting prematurely because water is backing up in the ice bin.

From Ice Maker

To Floor Drain

1. Normal Drain.

Proper Drainage Pitched from ice maker at least 1/4" per foot.

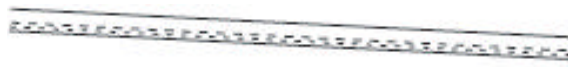

Proper Drainage

2. With Trap. Poor Drainage

Poor drainage. Water backs up in drain line.



Poor Drainage

3. With Trap and Vent. Proper Drainage

Vent assures proper drainage.

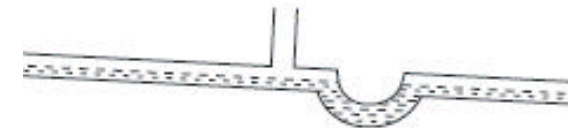

Proper Drainage

Examples of Gravity Drain Installations

Connecting a Drain Pump

Caution: Plumbing installation must observe all state and local codes. All water and drain connections **MUST BE** made by a licensed/qualified plumbing contractor. Failure to follow recommendations and instructions may result in damage and/or harm.

If a gravity drain connection is not available, Electrolux strongly recommends the use of the Electrolux drain pump. If your ice maker is not equipped with a factory installed pump, a drain pump is available through your Dealer, or direct Electrolux. If a pump other than the Electrolux drain pump is to be used, it must meet the following specifications:

- It must be UL listed and have a UL listed, 120 VAC, 3-wire grounded power cord.
- Overall maximum outside dimensions of 8-3/4" wide x 5-3/4" deep x 7-3/4" high.
- Minimum flow rate of 15 gallons per hour at 10 feet of lift.
- It must have a sealed sump which does not allow water leakage in the case of a power outage, restricted drain or pump failure.
- It must have a check valve in the discharge line to prevent waste water return to the pump.
- It must have an overflow protection control which will shut off power to the ice maker in the event of a pump failure.
- Operating temperature range of 50°F to 110°F (10°C to 40°C).

If your ice maker is not equipped with an Electrolux drain pump or an equivalent drain pump, severe damage and costly repair could result in the event of a power outage, restricted drain or pump failure.

Automatic Clean Cycle Instructions

To maintain operational efficiency, clean unit every six months (depending on water conditions more or less frequent cleaning may be necessary). If the ice maker requires more frequent cleaning, consult a qualified plumber to test the water quality and recommend appropriate treatment. Use only Electrolux Ice Machine Cleaner.

Caution: Use only Electrolux Ice Machine Cleaner. It is a violation of Federal law to use this solution in a manner inconsistent with its labeling. Use of any other cleaner can ruin the finish of the evaporator and will void the warranty. Read and understand all labels printed on the package before use. Ice machine cleaner is used to remove Lime scale and other mineral deposits. Refer to the following steps for mineral deposit removal.

1. Set the cycle selector switch (located in the center of the grille) to OFF. Allow the ice to melt off of the evaporator.
2. Remove all ice from the storage bin.
3. Remove inside front cover by gently pulling away from side wall.

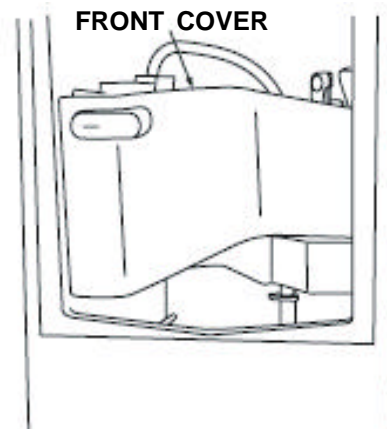

4. Remove the overflow tube by lifting it up while using a slight back and forth motion to loosen it from the drain hole.

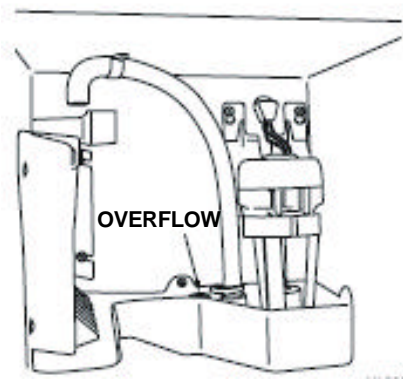

The water in the reservoir will flow down the drain.

5. Replace the overflow tube after all the water has been drained from the reservoir.
6. Move the cycle selector switch to the CLN position.
7. When water begins to flow over the evaporator, approximately three minutes, add one packet of Electrolux Ice Machine Cleaner to the reservoir.
8. Reinstall inside front cover.
9. When the self cleaning process stops, approximately 45 minutes, it may be desirable to clean the storage bin. See INTERIOR STORAGE BIN CLEANING.
10. Move the cycle selector switch to the ICE position to resume ice production.

Interior Storage Bin Cleaning

1. Disconnect power from the ice maker.
2. Remove any ice from the storage bin.
3. Wipe down the storage bin with a solution of nonabrasive mild soap or detergent and warm water. Rinse with clean water. Sanitize the bin with a solution of one tablespoon of bleach and one gallon of water. Rinse thoroughly with clean water.
4. Check that all drain connections are in place.
5. Reconnect power to the unit.

Sample Wiring Diagram

Note: Always refer to diagram on ice maker.

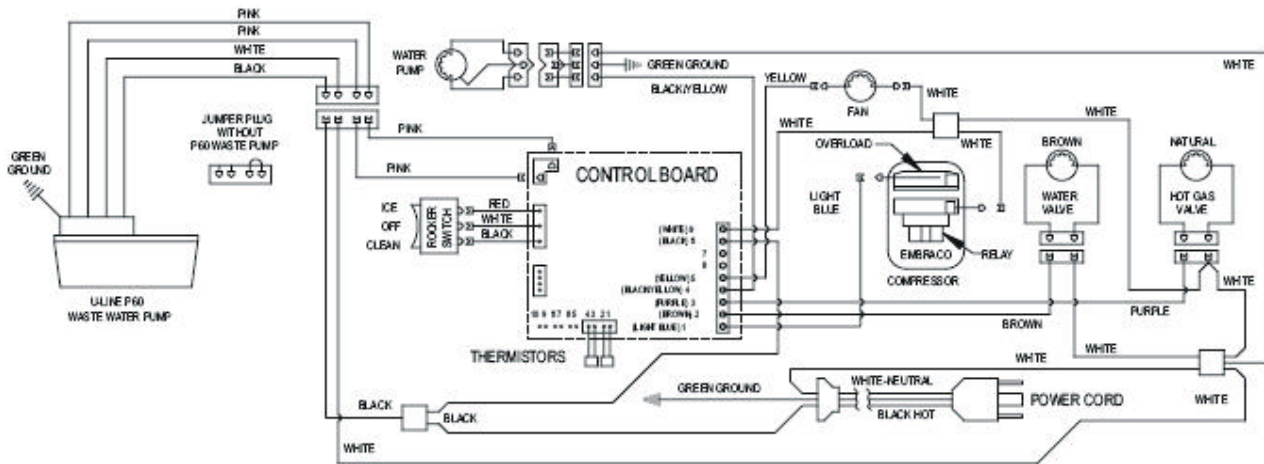

Electrical Specifications

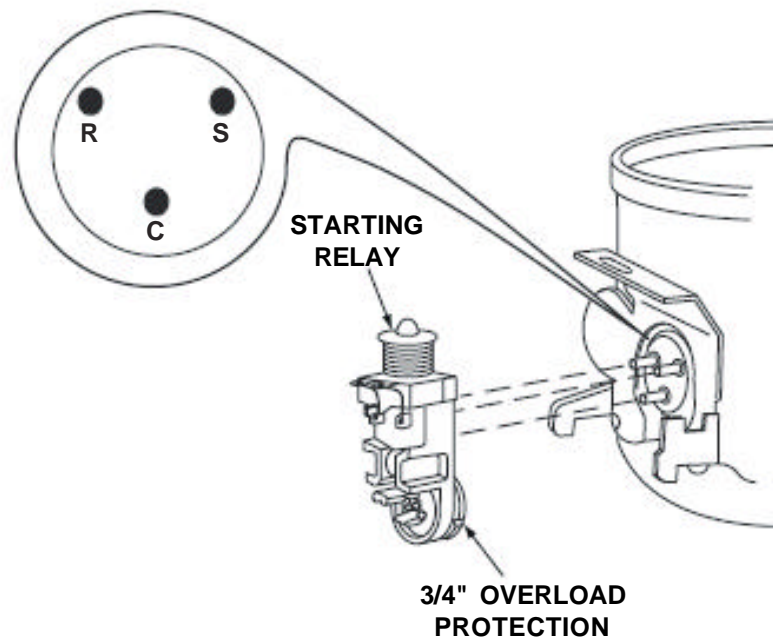

Compressor Pins:

To measure start winding resistance, measure across the C-S pins.

To measure run winding resistance, measure across the C-R pins. These pins should never measure any resistance to ground. This would indicate a shorted compressor.

Specifications:

Compressor Start Winding: 12.0 OHMS.

Compressor Run Winding: 2.9 OHMS.

Water Valve Coil Resistance: 280 OHMS.

Bypass Coil Resistance: 380 OHMS.

Pump Motor Winding Resistance: 71.5 OHMS.

Thermistor

The thermistor senses the refrigeration system “high side” temperature. This is used in conjunction with the control board to determine the length of the freeze and harvest cycles.

Thermistors generally fail due to moisture or physical damage. Electrolux “high side” thermistors are encased in a specially-designed, moisture-sealed aluminum block. The thermistor is also mounted to the “high side” or “dry” portion of the refrigeration system. This eliminates physical damage and moisture concerns.

Check Light on Control Board

The LED light on the control board serves three functions.

1. **Steady light** - The control board has power to it and operation is normal.
2. **Slow flash** - The control board has detected a sensor problem. This will happen if the thermistor's plug is disconnected from the control board. This will also happen if the thermistor fails open.
3. **Rapid flashing** - This indicates the control board is receiving a high heat signal from the thermistor. This can be caused by a dirty condenser, inadequate air flow (unit installed behind closed doors), failed condenser fan motor, etc.

In both the slow flash and rapid flashing situations, the unit will stop operation.

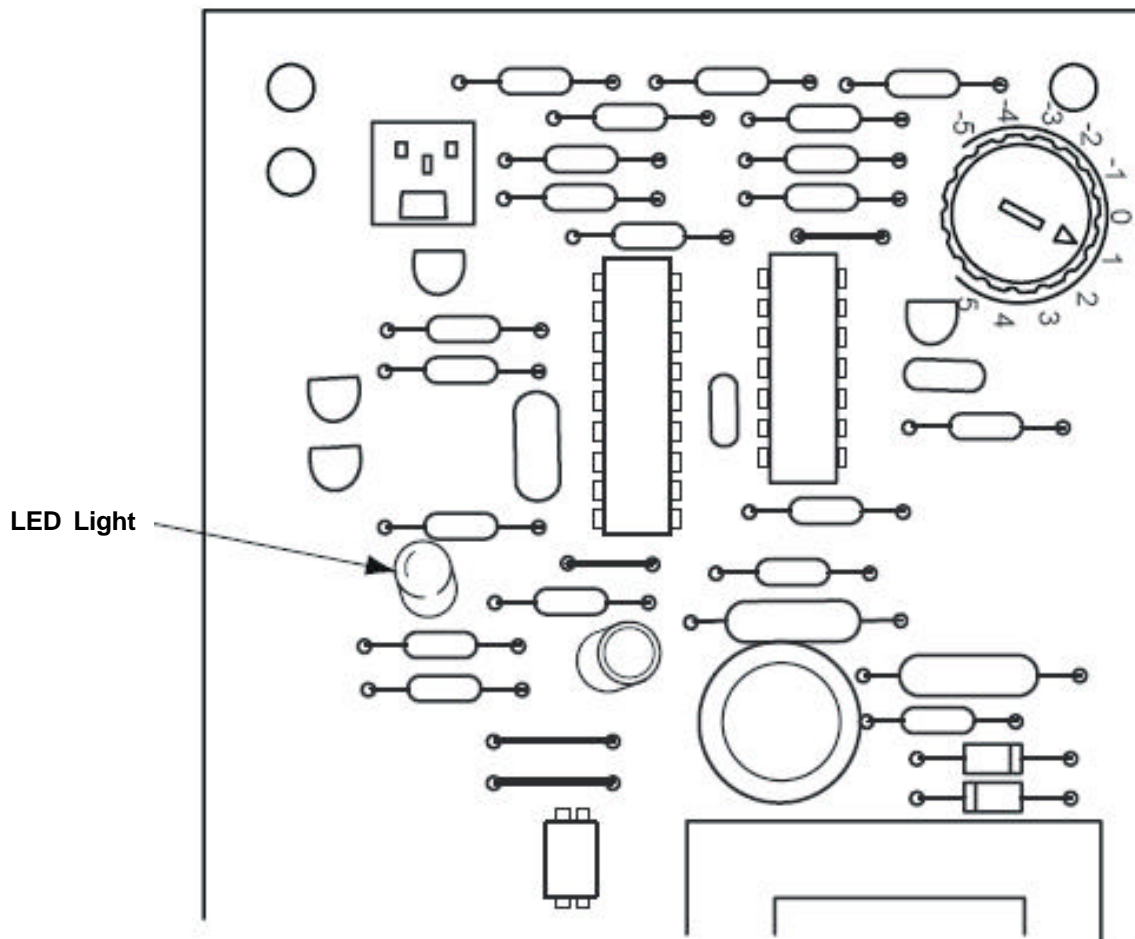

Low Side Pressure Changes

The chart below shows the low side pressure changes through the cycles of a Electrolux ice maker. It shows that during a harvest cycle, the low side pressures climb to nearly 60 psig. When the freeze cycle starts, the pressure quickly drops to approx. 17 psig and throughout the freeze cycle it continues to slowly drop to approximately 7 psig just before the harvest cycle.

This unit was operating in a 75° Fahrenheit ambient temperature and the incoming water temperature was 50° fahrenheit.

If a unit is operating in conditions other than these, the low side pressures will be different.

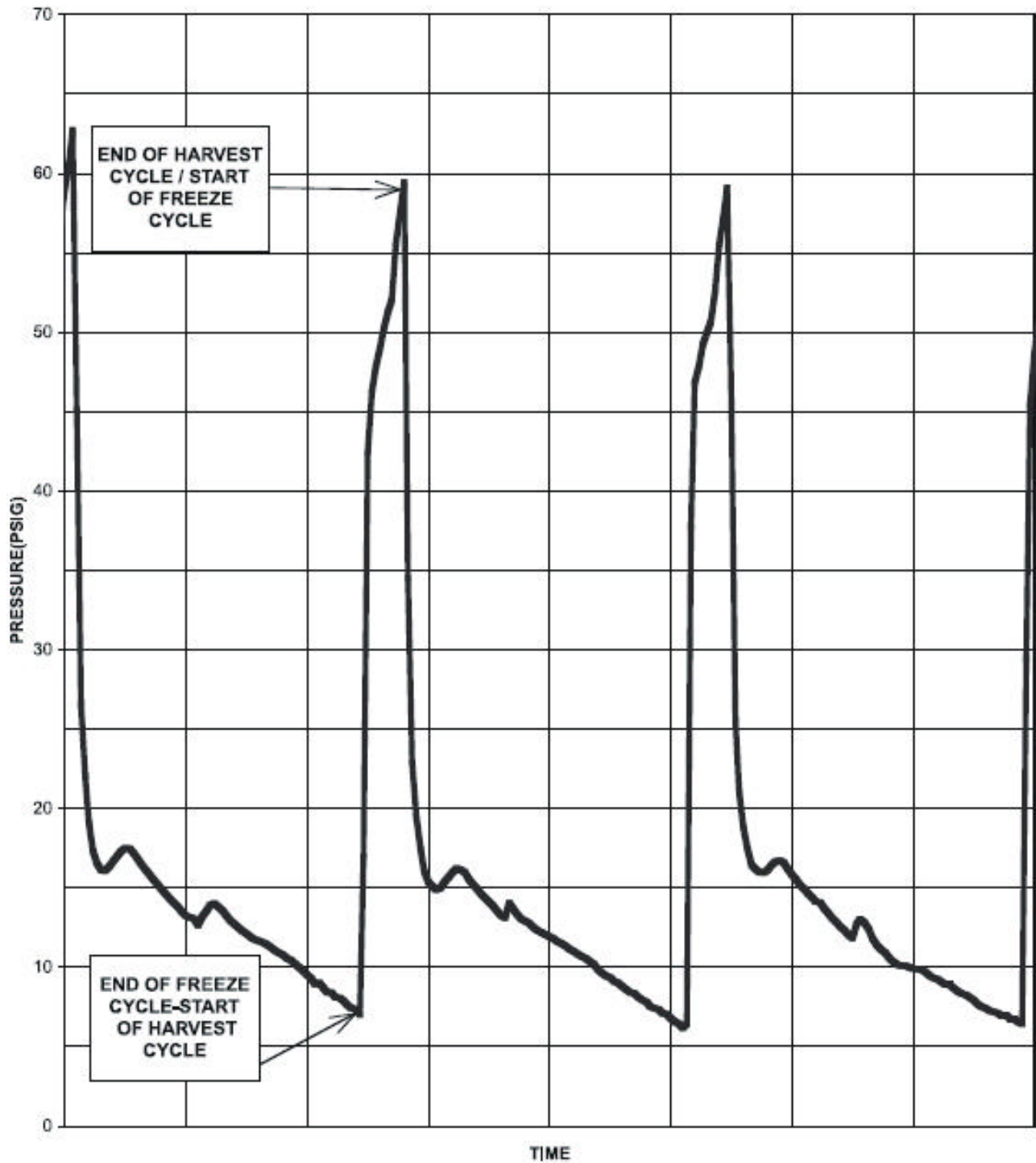

Ice Thickness Adjustment

The Clear Ice Maker uses advanced technology to make ice that is crystal clear. This technology cascades a flow of water over a chilled ice mold that is mounted vertically so no water sits in it. Because of this ice making technology, clear ice cubes differ significantly from regular ice cubes.

Differences are as follows:

- Dimples. Electrolux clear ice cubes have “dimples” on one side from the cascading water process.
- Cube Variations. Cubes made from different batches, or even cubes within the same batch may have varying dimples, thicknesses and/or sizes due to the cascading water process.
- Cube “slabbing”. The Electrolux clear ice maker makes a “slab” of ice that falls from the vertical mold relying on gravity to break the ice bridges. Depending on the control setting, and the fullness of the ice bucket, it may be necessary to tap the ice slab with the scoop to break it apart.

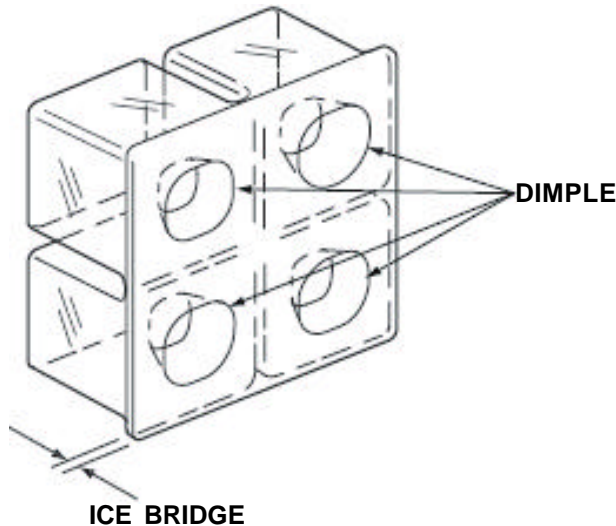

The ice cube thickness control is factory set for best overall performance. The factory setting is designed to maintain an ice bridge of approximately 1/16" to 1/8" under normal conditions resulting in a dimple of approximately 1/4" to 1/2" in depth.

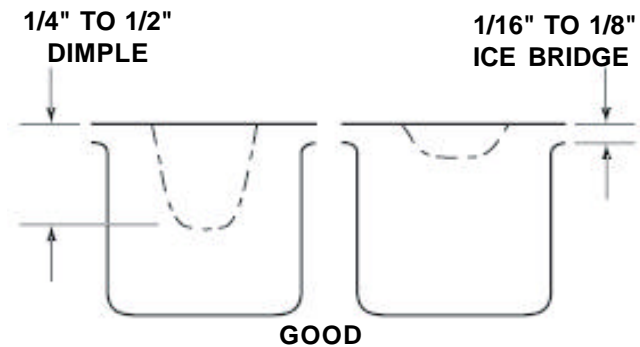

A fuller cube with less of a dimple results in a thicker ice bridge. As the ice bridge becomes thicker, the tendency for the cubes to stay together as a slab increases.

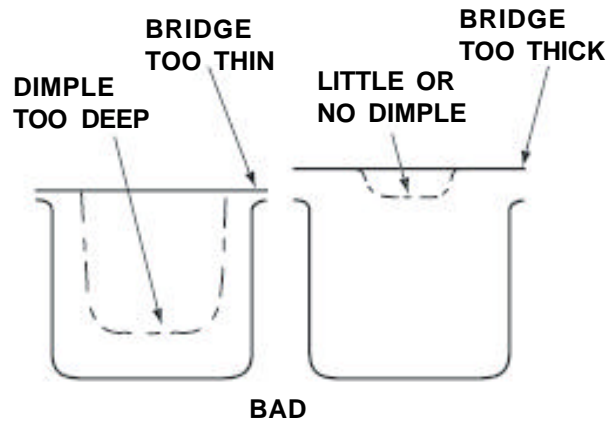

A bridge thicker than 1/8" may cause cubes to overfill the ice bucket.

Adjusting Ice Cube Thickness:



Disconnect power to the ice maker before making any ice thickness adjustments.

1. Disconnect power to the unit.
2. Remove the screws securing the front access panel.

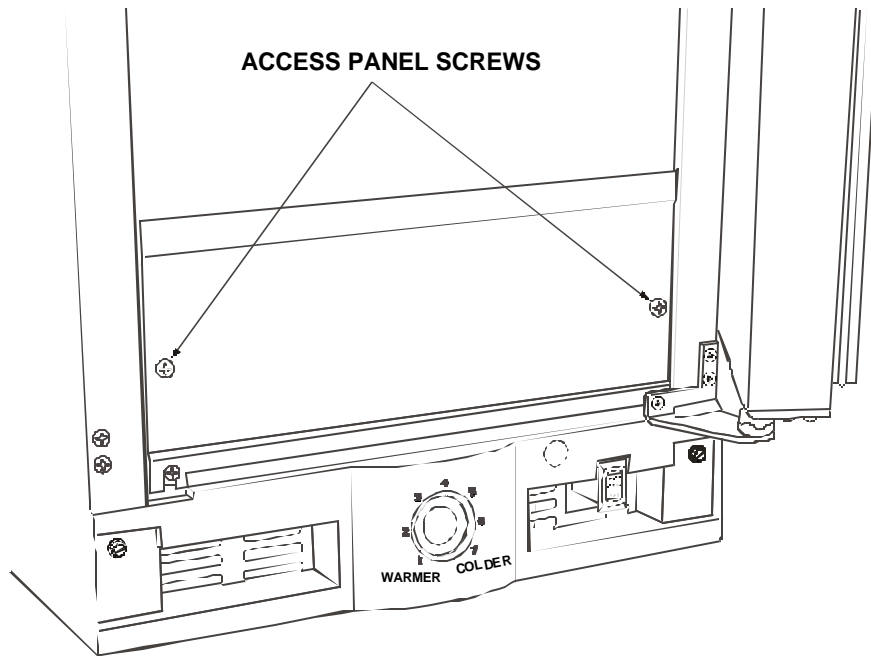

3. Locate the ice cube thickness adjustment dial on the control board. Turn the dial clockwise (+ number) to thicken or counterclockwise (- number) to thin the ice bridge.

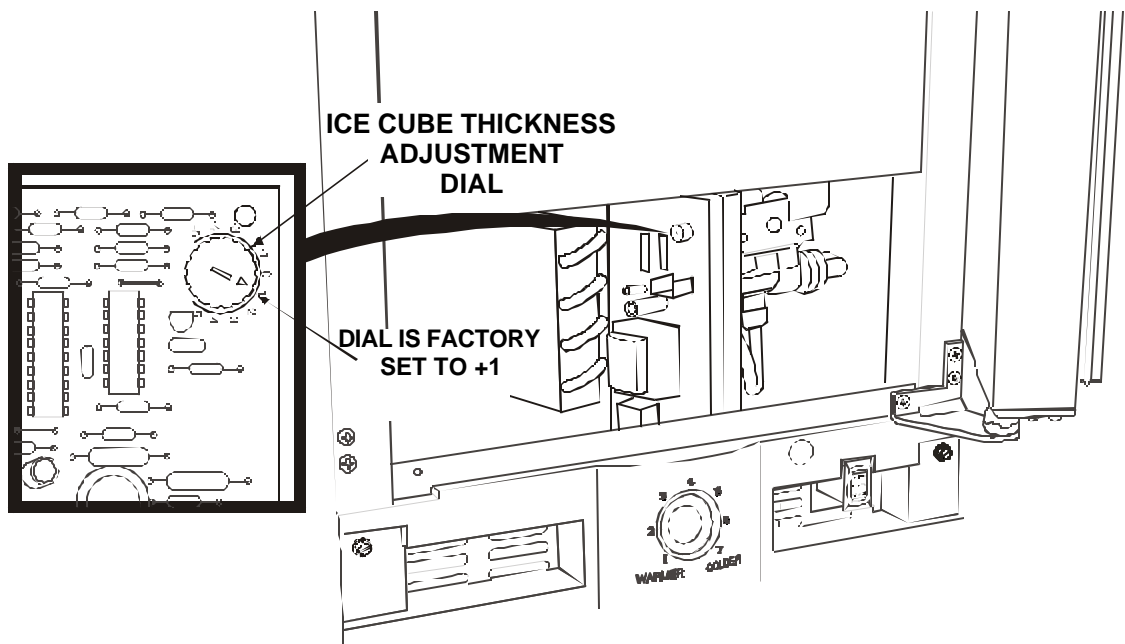

IMPORTANT: The door should never be flush with the top of the cabinet. Even when level, the top edge of the door will be 1/8" below the top of the cabinet.

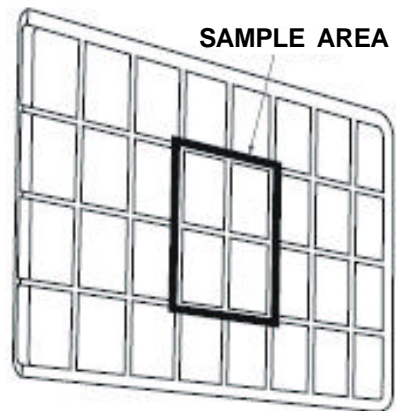

4. Reinstall front access cover.
5. Reconnect power to ice maker.
6. Empty ice bucket.

REFRIGERATION SYSTEM DIAGNOSIS GUIDE

System Condition	Suction Pressure	Suction Line	Compressor Discharge	Condenser	Capillary Tube	Evaporator	Wattage
Normal	Normal	Slightly below room temperature	Very hot	Very hot	Warm	Cold	Normal
Overcharge	Higher than normal	Very cold may frost heavily	Slightly warm to hot	Hot to warm	Cool	Cold	Higher than normal
Undercharge	Lower than normal	Warm - near room temperature	Hot	Warm	Warm	Extremely cold near inlet - outlet below room temperature	Lower than normal
Partial Restriction	Somewhat lower than normal-in vacuum	Warm - near room temperature	Very hot	Top passes warm - lower passes cool (near room temperature) due to liquid	Room temperature (cool) or colder	Extremely cold near inlet - outlet below room temperature backing up	Lower than normal
Complete Restriction	In deep vacuum	Room temperature (cool)	Room temperature (cool)	Room temperature (cool)	Room temperature (cool)	No refrigeration	Lower than normal
No Gas	0 PSIG to 25"	Room temperature (cool)	Cool to hot	Room temperature (cool)	Room temperature (cool)	No refrigeration	Lower than normal

Troubleshooting

DANGER
DO NOT service the unit until the main electrical power has been disconnected.

Problem	Cause	Correction
1. Unit does not operate (with drain pump; light on control board is not illuminated).	a. No electrical power to the unit.	a. Make sure unit is plugged in and outlet has power.
	b. Rocker switch set incorrectly.	b. Check switch wiring. Set to "ICE."
	c. Drain tube is kinked or obstructed.	c. Clear the tubing. If water cannot drain from pump, unit will shut down due to safety design of pump.
	d. Bad pump. Diagnose by bypassing the pump. Pull both pink wires from control board and jump the two terminals together. If unit starts up, then the pump is bad.	d. Change pump. Jumping the two terminals together on the control board with a jumper wire will eliminate pump from the circuit.
2. Unit does not operate (without drain pump; light on control board is not illuminated).	a. No power to unit.	a. Jumper plug off power cord.
3. Unit does not operate and light on control board is illuminated.	a. Bad bin thermostat.	a. Replace bin thermostat. The unit is falsely sensing a full bin.
	b. Bin thermostat set incorrectly.	b. Set bin thermostat at the 10:00 position.
4. No ice production.	a. No water supplied to unit.	a. Check that water is connected and turned on.
	b. Stand pipe not inserted in water trough.	b. Insert stand pipe securely into water trough.
	c. Re-circulating pump is defective.	c. Replace re-circulating pump.
5. Low ice production.	a. High ambient temperatures around unit.	a. Lower ice rate is normal with high ambient temperatures.
	b. Deposit build-up on evaporator grid.	b. Run the unit through a clean cycle. Use only Electrolux Ice Machine Cleaner.
	c. Ice thickness dial set incorrectly.	c. Adjust ice thickness dial accordingly.
	d. Dirty condenser coil.	d. Clean condenser coil.

NOTE: Light on control board will indicate if condenser is too dirty. A rapid flash of light indicates high heat conditions which could be caused by either an inadequate air flow or a dirty condenser.

Problem	Cause	Correction
6. Will not eject ice (water frozen).	<ul style="list-style-type: none"> a. Bin thermostat set incorrectly. b. Wiring plug off of bypass valve coil. c. Defective bypass valve. d. Deposit build-up on evaporator grid. 	<ul style="list-style-type: none"> a. Set bin thermostat at 10:00 position. b. Re-install plug. c. Replace bypass valve. d. Run unit through the clean cycle. Use only Electrolux Ice Machine Cleaner. If scale or mineral deposits accumulate on grid, cubes will not fall freely.
7. Ice is slow to release from evaporator.	<ul style="list-style-type: none"> a. Deposit build-up on evaporator grid. b. Unit not level. 	<ul style="list-style-type: none"> a. Run unit through the clean cycle. Use only Electrolux Ice Machine Cleaner. b. Level unit for even water flow. Uneven water flow will reduce ice rate and cause water to spill in ice bin.
8. Will not fill with water.	<ul style="list-style-type: none"> a. No stand pipe in water trough. b. Water valve is defective. c. Water solenoid unplugged or wire to solenoid has internal break. 	<ul style="list-style-type: none"> a. Install stand pipe. b. Replace valve. c. Repair wiring defect.
9. Continuous ice production.	<ul style="list-style-type: none"> a. Bin thermostat set too cold. b. Bin thermostat sensing bulb out of alignment. c. Bin thermostat stuck in closed position. d. Ice slab too thick. 	<ul style="list-style-type: none"> a. Set bin thermostat to the 10:00 position. b. Insert bulb inside aluminum sensor tube. c. Replace bin thermostat. d. Set ice thickness adjustment dial to a lower setting. If cubes release from grid and are too thick, cubes might not make contact with sensor tube (inside of bin); therefore bin thermostat would never be satisfied.

Problem	Cause	Correction
10. Low (or no) ice production.	a. Dirty condensing coil (Control board light shows rapid flash).	a. Clean condensing coil.
	b. Stalled condenser fan blade (Control board light shows a rapid flash).	b. Free up the blade or replace fan motor.
	c. No water in water trough.	c. Install stand pipe securely in trough.
	d. Bypass valve stuck in open position.	d. Replace bypass valve.
	e. Ice forms on a portion of evaporator grid.	e. Check unit for system under charge or leak.
NOTE: See chart of suction pressures in manual.		
11. Poor ice quality (soft or unclear cubes)	a. Poor incoming water quality.	a. Consult a plumber.
	b. Deposit build-up on evaporator grid.	b. Run the unit through a clean cycle. Use only Electrolux Ice Machine Cleaner.
	c. Water splashing on cubes.	c. Adjust water flow above evaporator.
12. Unit not freezing (compressor and fan operating)	a. Little or no cooling.	a. Check sealed system for leak or restriction.
	b. Bypass valve stuck in open position.	b. Replace bypass valve.

Problem	Cause	Correction
13. Unit produces shallow or incomplete cubes or the ice fill pattern on the grid is incomplete.	a. Low water level.	a. Check that standpipe is fully seated inside water trough.
	b. Low water pressure.	b. Check water pressure into water valve (pressure should be 20 to 120 psi).
	c. Unit is not level.	c. Level unit to assure even water flow. Uneven water flow will reduce ice rate and cause incomplete cubes. See Leveling Instructions in manual.
	d. Operating unit without back or front panel.	d. Install back or front panel. The unit will harvest ice according to temperatures of tubing at condensing coil. Increased air flow will give the thermister false information. This info could cause the ice to eject prematurely.
	e. Bad thermister.	e. Replace thermister.
	f. Bad control board.	f. Replace control board.
14. Not freezing compressor not running / fan operating.	a. Bad overload (open).	a. Replace overload.
	b. Bad compressor.	b. Replace compressor.
15. Not freezing (compressor and fan not operating)	a. No electrical power to unit.	a. Make sure unit is plugged in and outlet has power.
	b. Rocker switch defective or wired incorrectly.	b. Make sure switch is wired correctly and set in "ICE" position.
16. If the unit has a drain pump.	a. Drain tube kinked or obstructed.	a. Clear the tubing. If water cannot drain from pump, unit will shut down due to safety design of pump.
	b. Bad pump. Diagnose by bypassing the pump. Pull both pink wires from control board and jump the two terminals together. If unit starts up, then the pump is bad.	b. Change pump. Jumping the two terminals on control board together with a jumper wire will eliminate pump from the circuit.
	c. Open wire in wiring harness.	c. Trace defective wire and repair or replace parts accordingly.

Problem	Cause	Correction
17. Water leak under unit.	<ul style="list-style-type: none"> a. Incoming water supply line leaking. b. Fill tube leaking. 	<ul style="list-style-type: none"> a. Make sure brass connection is screwed tight to valve and threaded correctly. b. Tighten fill tube connection to water line. c. Unit not repairable. Contact Electrolux tech line for assistance.
18. Water in ice bin.	<ul style="list-style-type: none"> a. Bin drain kinked or restricted. b. External drain is restricted. c. Bad pump. 	<ul style="list-style-type: none"> a. Clear drain of obstruction or kink. b. Clear restriction. c. Replace pump.
19. Water will not stop filling.	<ul style="list-style-type: none"> a. Water solenoid stuck in open position. b. Open relay on control board. <p>NOTE: A defective relay on control board would cause both the water valve and reversing valve to stay open, therefore, this failure would not allow the unit to freeze.</p>	<ul style="list-style-type: none"> a. Replace water valve. b. Replace control board.
20. Unit noisy.	<ul style="list-style-type: none"> a. Fan motor not secured to bracket. b. Fan blade bent. c. Vibration from refrigerant lines. d. Obstruction in fan blade. 	<ul style="list-style-type: none"> a. Tighten motor. b. Realign or replace blade. c. Secure tubing. d. Remove obstruction.

