

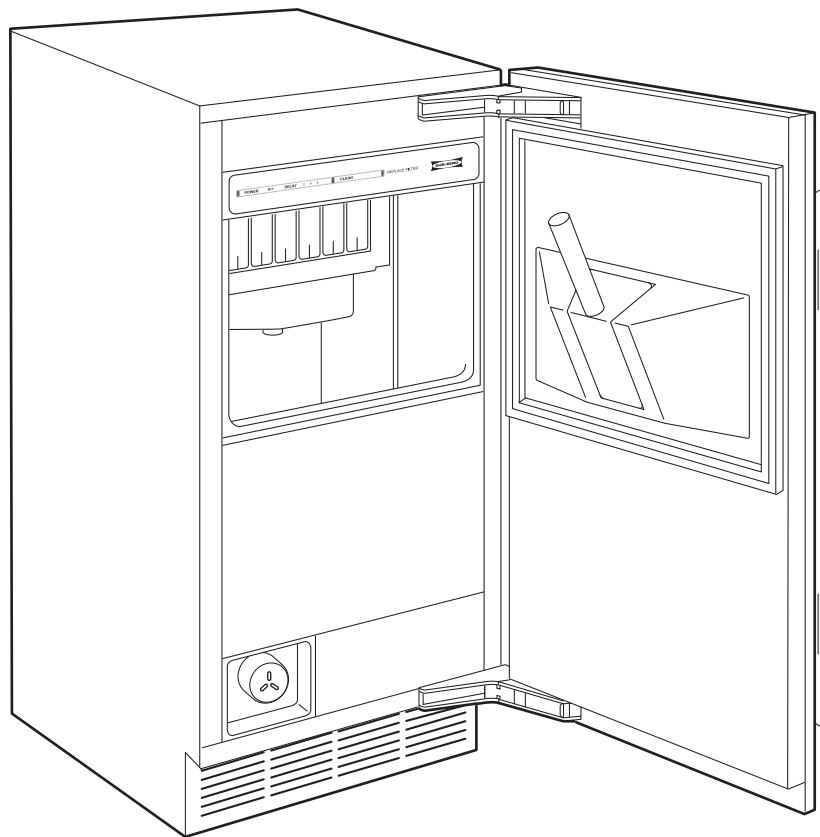

TECHNICAL SERVICE MANUAL



MODEL UC-15I ***(Undercounter Ice Machine)***



SECTION 1

GENERAL INFORMATION



INTRODUCTION

This Sub-Zero Technical Service (Job Aid Part #7012423) is a compilation of data, specifications and illustrations from Sub-Zero, Inc. and Manitowoc FSG Operations, Inc.. The information in this manual has been produced for Sub-Zero service training and service repair purposes with permission from Manitowoc FSG Operations, Inc. This manual will provide the most recent service information about the model UC-15I. This information will enable the service technician to diagnose malfunctions, perform necessary repairs and return a model UC-15I appliance to proper operational status.

The service technician should read the complete instructions contained in this manual before initiating any repairs on a model UC-15I.

IMPORTANT SAFETY INFORMATION

Below are the Product Safety Labels used in this manual. The "Signal Words" used are **WARNING** or **CAUTION**.

When reviewing this manual, please note these different Product Safety Labels placed at the beginning of certain sections of this manual. You must follow the instructions given in the boxes below the Product Safety Labels in order to avoid personal injury and/or product damage.

The sample Product Safety Labels below illustrate the precautions that should be taken when the signal word is observed.

⚠ WARNING

INDICATES THAT HAZARDOUS OR UNSAFE PRACTICES COULD RESULT IN SEVERE PERSONAL INJURY OR DEATH

⚠ CAUTION

Indicates that hazardous or unsafe practices could result in minor personal injury or product and/or property damage

In addition, please pay attention to the signal word "**NOTE**", which highlights information that is especially important for the topic being covered.

This manual was designed to be used by Authorized Service Personnel only. Sub-Zero, Inc. assumes no responsibility for any repairs made on Sub-Zero refrigeration units by anyone other than Authorized Service Technicians.

TECHNICAL ASSISTANCE

If you should have any questions regarding the appliance and/or this manual, please contact:

Sub-Zero, Inc.
 ATTN: Service Department
 P.O. Box 44988
 Madison, WI 53744 - 4988

Customer Assistance
 Phone #: (800) 222 - 7820
 Facsimile #: (608) 441 - 5887

Technical Assistance
 (For Technicians in Customer's Homes Only)
 Phone #: (800) 919 - 8324

Warranty Claims
 Phone #: (800) 332 - 9513
 Facsimile #: (608) 441 - 5886

Service Department e-Mail Address:
 customerservice@subzero.com

Office Hours:
 7:00 AM to 6:00 PM Central Time
 Monday through Friday

The information and images contained in this manual are the copyright property of Sub-Zero, Inc. Neither this manual nor any information or images contained herein may be copied or used in whole or in part without the express written consent of Sub-Zero, Inc. ©, all rights reserved.



TABLE OF CONTENTS

	Page #		Page #
Section 1 - General Information	1-1	Section 4 - Maintenance, Cleaning & Adjustments	4-1
Introduction	1-2	Ice Maker Cleaning and Maintenance.....	4-2
Important Safety Information	1-2	Recommended Cleaning / Maintenance Schedule	4-2
Technical Assistance	1-2	Cleaning the Exterior	4-2
Table of Contents	1-3	Cleaning the Condenser	4-2
Warranty Information	1-5	Cleaning & Sanitizing the Interior	4-3
Serial Number Tag Information	1-5	In Place Cleaning / Sanitizing	4-3
Model Description	1-6	Disassembly Cleaning / Sanitizing	4-4
Components / Features	1-6	Removal of Parts for Cleaning	4-5
Section 2 - Installation Information	2-1	Top Cover	4-5
Pre-Installation Considerations	2-2	Splash Shield	4-5
Electrical Requirements	2-4	Water Shutter Assembly	4-5
Plumbing Requirements	2-5	Ice Chute	4-6
Installation Procedure	2-7	Water Trough Drain Tube & Standpipe/Overflow Tube ...	4-6
Leveling	2-9	Water Trough	4-6
Securing the Ice Machine	2-9	Spray Bar Assembly	4-7
Side Panels	2-9	Water Pump	4-7
Reversing the door Swing	2-9	Removal from Service/Long Term Storage/Winterization ..	4-8
Door Panel Installation	2-11	Water Filter Replacement	4-8
Door Panel Dimensions	2-11	Adjustments	4-9
Panel Preparation and Installation	2-11	Cube Weight Check and Adjust	4-9
90-Degree Door Stop Installation	2-12	Testing and Adjusting Bin Thermostat	4-9
Hinge Cover Installation	2-12	Section 5 - Component Access and Removal	5-1
Section 3 - Theory of Operation	3-1	Section 5 Table of Contents	5-2
Control Panel	3-2	Access and Removal WARNINGS and CAUTIONS	5-2
POWER Button (Green Indicator Light)	3-2	Section 6 - Troubleshooting Guide	6-1
Automatic Ice Making Light (Blue Indicator Light)	3-2	Troubleshooting Guide	6-2
DELAY Start	3-2	How to Use the Troubleshooting Guide	6-2
CLEAN Button (Green Indicator Light)	3-2	Warning	6-2
REPLACE FILTER (Red Indicator Light)	3-2	Troubleshooting Guide Layout	6-2
Operating Systems	3-3	Troubleshooting Guide	6-3
Refrigeration System	3-3	Section 7 - Technical Data Tables	7-1
Water System	3-4	Water and Ice Information	7-2
Electrical System	3-4	Sealed System Information	7-2
Operational Cycles	3-5	Electrical Information	7-2
Ice Making (Freeze) Cycle	3-5	Section 8 - Wiring Diagrams & Schematics	8-1
Harvest Cycle	3-6	Model UC-15IP	8-2
What to Expect from the Model UC-15I	3-7		
Ice	3-7		
Storage	3-7		
Run Time	3-7		
Testing & Adjusting the Ice Bin Thermostat	3-8		
Resting the Bin Thermostat	3-8		
Adjusting the Bin Thermostat	3-8		
Cube Weight Adjustment	3-8		
Adjusting Freeze Cycle finish Time	3-8		
Checking the Additional Freeze Cycle Time	3-8		



WARRANTY INFORMATION

This page contains summaries of the 2, 5 & 12 Year Warranties that are supplied with Sub-Zero Appliances.

TWO, FIVE & TWELVE YEAR Warranty Summary

- Two year TOTAL PRODUCT warranty, *parts and labor.
- Five Year SEALED SYSTEM warranty, **parts and labor.
- Sixth through Twelfth year LIMITED SEALED SYSTEM warranty, sealed system **parts only.

ONE & FIVE YEAR Non-Residential Warranty Summary (Outdoor Models ONLY)

- One Year TOTAL PRODUCT warranty, *parts and labor.
- Five year LIMITED SEALED SYSTEM warranty, sealed system **parts only.

ONE & FIVE YEAR Display / Model Home Warranty Summary (Display units sold three years after date of manufacture)

- One Year TOTAL PRODUCT warranty, *parts and labor.
- Five year LIMITED SEALED SYSTEM warranty, sealed system **parts only.

Warranty Details:

* Total Product Parts include, but is not limited to: Control, Circulating Pump, Switches, Fan Motor & Blade, Drain Tube, Wiring, Water Valve, Hot Gas Valve, Door hinges, Compressor Electricals, etc. . .

NOTE: The ice machine must be protected if it will be subjected to ambient temperatures below 32°F (0°C). Component failure caused by exposure to freezing temperatures is not covered by the warranty.

** Sealed System Parts include the following:

Compressor, Condenser, Evaporator, Filter-Drier, Heat-exchanger, All Tubing That Carries the Freon.

NOTE: Condenser Fan Motor, Freon, Solder and compressor electricals are NOT considered sealed system parts.

General Warranty Notes:

- Sub-Zero, Inc. assumes no liability or responsibility for Sub-Zero products that have been altered in any way, including the use of parts and/or components not specifically approved by Sub-Zero.
- All warranties begin at the time of the unit's initial installation.
- The serial tag is located in two places: one on the left wall of the ice bin and one on the back of the unit. (See Diagram below). Please have this information whenever contacting the factory or parts distributor.

Serial Number Tag Information:

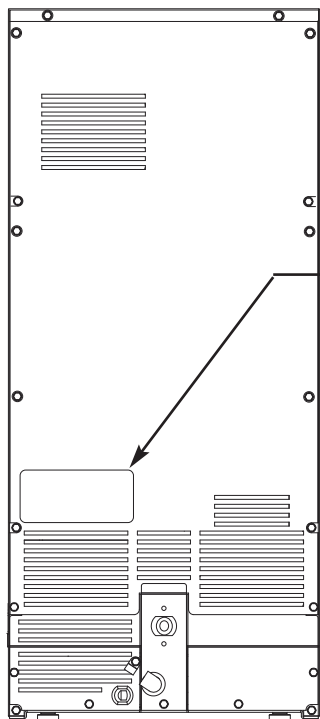

MODEL UC15IO	SERIAL NO. XXXXXX	
	MFG DT 0809	
DESIGN PRESSURE HIGH SIDE	350	P. S. I. G.
DESIGN PRESSURE LOW SIDE	250	P. S. I. G.
REFRIG. TYPE R-134A	REFRIG. CHARGE 5.6OZ.	
VOLTS 115V	CYCLE 60 Hz	PHASE 1
TOTAL AMPS 4.1 A		
URC		
DPMCRE2	SUBZERO FREEZER CO. INC.	

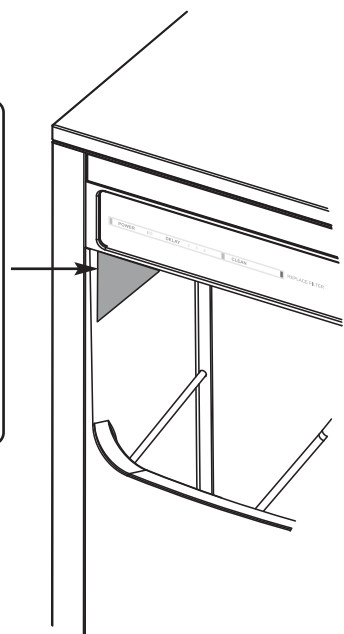



MODEL DESCRIPTION

Models UC-15I and UC-15IO have a gravity drain, while Models UC-15IP and UC-15IPO have a built-in pump to allow greater installation flexibility.

Model Features

- 24" (610 mm) depth design for a complete integrated look.
- Door accepts custom panels.
- Automatic ice machine provides high-quality, clear ice.
- Ice storage bin capacity of up to 25 lbs (11 kg).
- Automatic defrost.
- Reversible door swing.
- Front venting with removable kickplate allows unit to be serviced from the front.
- Solid core door with gasket and door closer.
- UL approved for US and Canada, with the UC-15IO and UC-15IPO being UL approved for outdoor use.

COMPONENTS / FEATURES

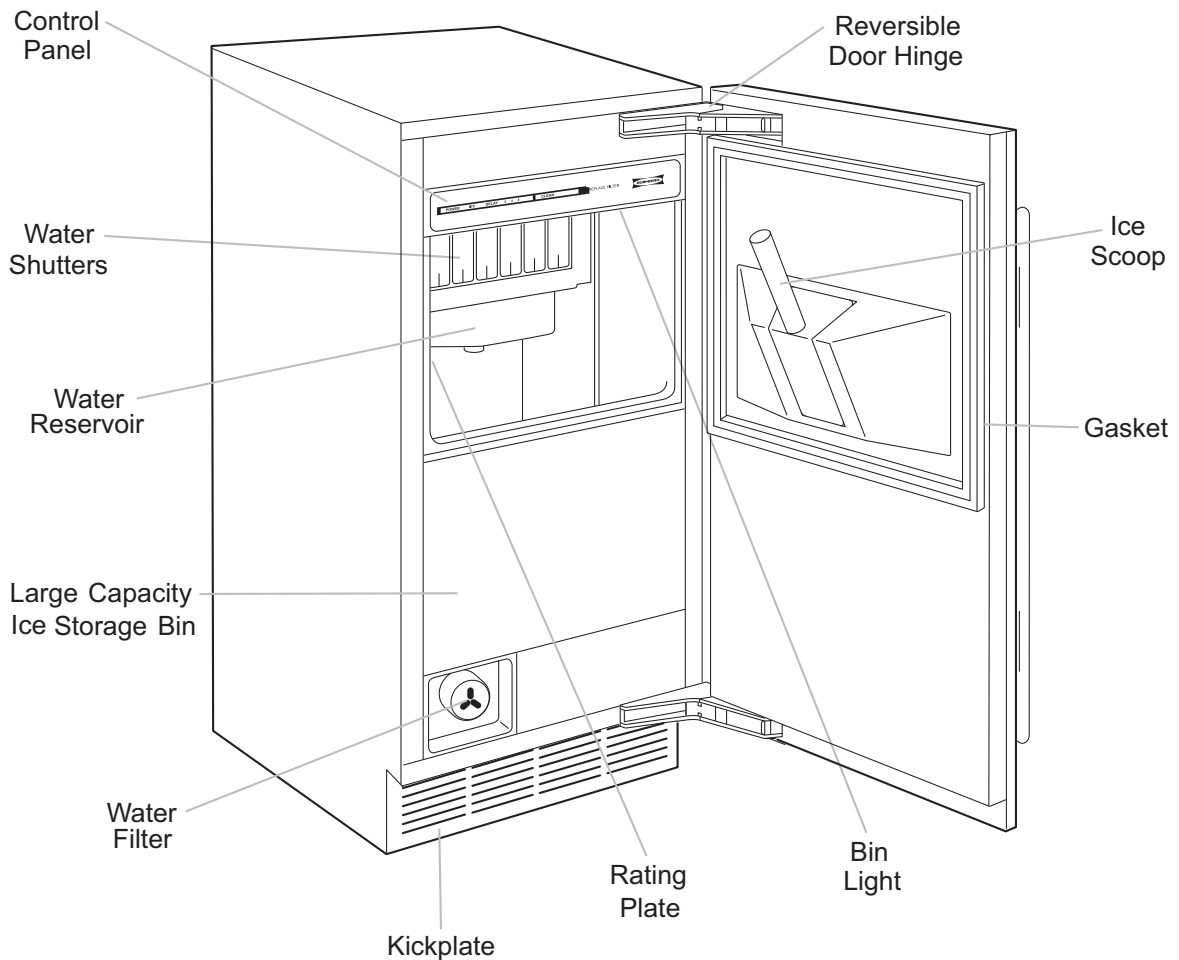



SECTION 2

INSTALLATION INFORMATION



PRE-INSTALLATION CONSIDERATIONS

To properly make and store ice, the model UC-15I:

- Must have an open site (gravity) drain available (applies to models without a drain pump only). Refer to specifications found later in this section.
- Must have a grounded, polarized electrical power supply on a separate circuit servicing only this appliance. If GFCI (ground fault circuit interrupter) is required by local electrical code or is part of an outdoor installation, it must be breaker type, not outlet type. Refer to specifications found later in this section.
- Must have a cold water supply line available at ice machine. Refer to specifications found later in this section.
- Specifications for clearance and air temperature requirements must be met. Refer to specifications found later in this section.
- Must be removable for yearly cleaning procedure. Refer to specifications found later in this section.

⚠ WARNING

PROPER INSTALLATION REQUIRES CONNECTION TO A WATER SUPPLY, A DRAIN AND A DEDICATED ELECTRICAL CIRCUIT. THESE CONNECTIONS ARE THE RESPONSIBILITIES OF THE OWNER/OPERATOR. IMPROPER CONNECTIONS CAN RESULT IN PERSONAL INJURY, SUBSTANTIAL PROPERTY DAMAGE AND ERRATIC MACHINE OPERATION. IF UNABLE TO SAFELY CONNECT THE ICE MACHINE, CONSULT QUALIFIED PROFESSIONALS OR CONTACT SUB-ZERO.

NOTE: Failure to follow installation guide lines may affect warranty coverage.

OVERALL DIMENSIONS

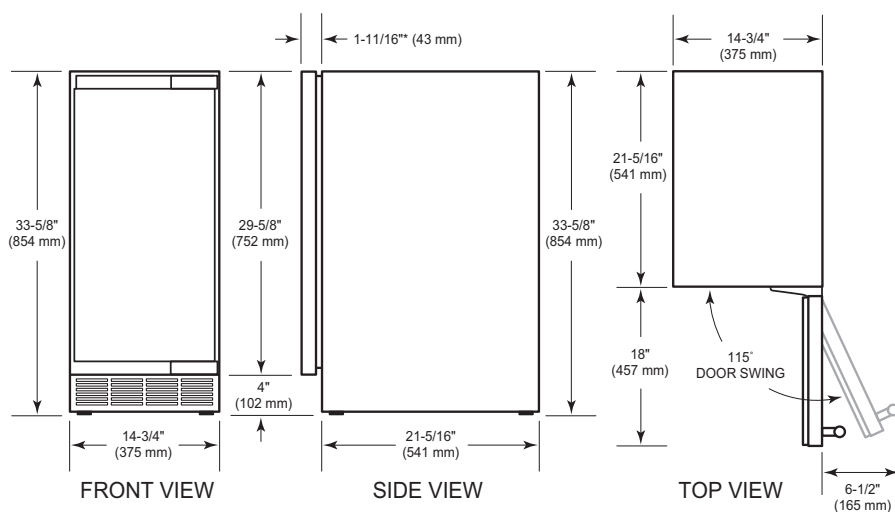

*Does not include door panel

Dimensions in parentheses are in millimeters unless otherwise specified.

ALL MODELS

Overall Width	14-3/4" (375 mm)
Overall Height (levelers in)	33-5/8" (854 mm)
Overall Depth	23" (584 mm)
Minimum Door Clearance	18" (457 mm)
Rough Opening Width	15-1/4" (387 mm)
Rough Opening Height	34-1/2" (876 mm)
Minimum Height Required (levelers in)	33-5/8" (854 mm)
Rough Opening Depth	24" (610mm)

Dimensions may vary ± 1/8" (3 mm).



Location of the Ice Machine

The location selected for the ice machine must meet the following criteria. If any of these criteria are not met, select another location.

- The ice machine may be built into a cabinet, however the location must allow removal of the ice machine for cleaning and servicing. Service diagnostics are performed from the top of the ice machine.
- The location must be free of airborne and other contaminants.
- Do not place the unit within 18" (457) of a trash compactor or trash/recycling container.
- The air temperature must be at least 50°F (10°C). But, the air temperature must not exceed 100°F (38°C) for models UC-15I and UC-15IP, and 110°F (43°C) for models UC-15IO and UC-15IPO.
- The location must not be near heat-generating equipment.
- The location must not obstruct air flow through the kickplate (airflow is in and out the front of the ice machine).
- The location must allow enough clearance for water, drain and electrical connections at the rear of the ice machine.
- Models UC-15IO and UC-15IPO are designed and approved for outdoor installation.

⚠ CAUTION

The ice machine must be protected if it will be subjected to ambient temperatures below 32°F (0°C). Component failure caused by exposure to freezing temperatures is not covered by the warranty.

Area Requirements

Before moving the ice machine into place, be sure the finished opening dimensions, electrical location and plumbing location are accurate.

Be sure the plumber, electrician and cabinet installer have this information before finishing work is completed.

Models UC-15I and UC-15IO are gravity drain models that require a drain tube that is pitched down from the outlet at the back of the unit to the sanitary sewer connection.

Models UC-15IP and UC-15IPO have a built in drain pump that will pump water up to a drain point, such as a nearby sink. Refer to specifications found later in this section.

NOTES:

- *If the ice machine is installed in a corner, the door swing may be limited due to handle contact with the wall or cabinet face.*
- *The floor under the ice machine must be at the same level as the surrounding finished floor.*
- *When moving the unit, use a hand truck or dolly, position the dolly on the side of the unit and secure the door so it does not open while transporting the unit.*

⚠ CAUTION

Any finished flooring should be protected with appropriate material to avoid any damage from moving the unit.



ELECTRICAL REQUIREMENTS

Prepare electrical circuit before installation of the ice machine. Installation requires a grounded (three-prong), polarized receptacle (See Figure 2-2), with a separate fuse/circuit breaker in an electrical service box.

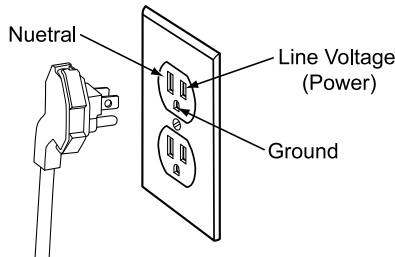

Proper Three-Prong Polarized Receptacle

NOTE: All National Electrical Code regulations must be followed. In addition, be aware of local codes and ordinances when installing the services.

Voltage

⚠ WARNING
ELECTRICAL SHOCK HAZARD. DO NOT USE AN EXTENSION CORD OR TWO PRONG ADAPTER. ELECTRICAL GROUND IS REQUIRED ON THIS APPLIANCE. DO NOT REMOVE THE POWER SUPPLY CORD GROUND PRONG.

All electrical work, including wire routing and grounding, must conform to local, state and national electrical codes. The following precautions must be observed:

- The ice machine must be grounded.
- A separate fuse/circuit breaker must be provided for each ice machine.
- The maximum allowable voltage variation is +/-10% of the rated voltage at ice machine start-up (when the electrical load is highest).

- The minimum wire size is #14 for less than 100 feet (30.5 m) or #12 for more than 100 feet (30.5 m) to 200 feet (61 m) (solid copper conductor only). The recommended breaker is 15 amp. Local or state electrical code, length of run or materials used, can increase the minimum wire gauge required. A qualified electrician must determine the proper wire size, although #14 is the minimum size allowed.

NOTE: Observe correct polarity of incoming line voltage. Incorrect polarity can lead to erratic ice machine operation and a safety issue.

Minimum Circuit Requirements

The minimum circuit requirement is used to help select the wire size of the electrical supply.

NOTE: Minimum Circuit Amps listed below is not the ice machine's running amp load.

MAXIMUM BREAKER SIZE AND MINIMUM CIRCUIT AMPERAGE

Voltage / Phase / Cycle	115 / 1 / 60
Maximum Fuse/Circuit Breaker Amps	15
Minimum Circuit Amps	4.1

GFCI Requirements

For Models UC-15IO and UC-15IPO or if a GFCI (ground fault circuit interrupter) is required by local electrical code, it must be breaker type.

INSTALLATION SPECIFICATIONS

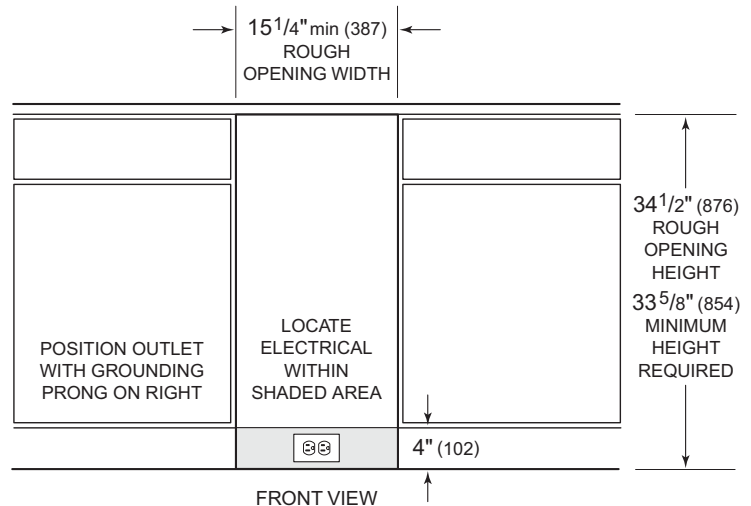

Dimensions in parentheses are in millimeters unless otherwise specified.



PLUMBING REQUIREMENTS

NOTE: Plumbing must conform to state and local codes.

Water Supply

Prepare water supply line and drain before installation of the ice machine. Installation requires a minimum 1/4" ID copper cold water line and compression fitting (not supplied). Models UC-15I and UC-15IO are supplied with a drain hose for gravity draining. The optional drain pump or pump models UC-15IP and UC-15IPO must be purchased if a gravity drain is not possible. Both drain methods require routing to an open site drain. Do not connect directly to drain line as bacteria from drain line may contaminate the ice machine.

The included water filter is designed to inhibit scale formation, filter sediment, and remove chlorine odor and taste. The life expectancy of the water filter is 6 months during normal usage. The ice machine control board will monitor water usage and indicate when replacement is required.

Water Inlet Lines

Follow these guidelines to install water inlet lines:

- Do not connect the ice machine to a hot water supply. Be sure all hot water restrictors installed for other equipment are working. (Check valves on sink faucets, dishwashers, etc.)
- If water pressure exceeds the maximum recommended pressure (80 psi–551.5 kPA), obtain a water pressure regulator from a local plumbing contractor.
- Install a water shut-off valve for the ice making water lines.
- Insulate the water inlet line to prevent condensation.

Drain Connections

Follow these guidelines when installing drain lines to prevent drain water from flowing back into the ice machine and storage bin:

- Drain lines must have a 1-1/2" drop per 5 feet of run (2.5 cm per meter), and must not create traps.
- The floor drain must be large enough to accommodate drainage from all drains.
- Drain pump discharge line must terminate at an open site drain.
- Maximum rise – 12 feet (3.7 m)
- Maximum run – 100 feet (30.5 m).

APPROXIMATE HEIGHT OF ICE MACHINE DRAIN

Standard Installation	5" (127mm)
-----------------------	------------

⚠ CAUTION

Improper drainage can lead to water flowing back into ice machine and poor performance.



WATER SUPPLY AND DRAIN LINE SIZING / CONNECTIONS

	Water Temperature	Water Pressure	Ice Machine Fitting	Tubing size up to Ice Machine Fitting
Ice Making Water Inlet	50°F (10°C) Min. 80°F (27°C) Max.	20 psi (137.9 kPA) Min. 80 psi (551.5 kPA) Max.	1/4" (6.4 mm) ID Copper Tubing	1/4" (6.4 mm) minimum Inside Diameter
Models UC-15I and UC-15IO	—	—	3/4" (19mm) Hose Barb	3/4" (19mm) minimum Inside Diameter
Models UC-15IP and UC-15IPO	—	—	3/8" (9.5mm) Hose	3/8" (9.5mm) minimum Inside Diameter

NOTES

- If air temperature is less than 60°F (16°C), water temperature must be equal to or greater than 50°F (10°C).
- Plumbing must conform to state and local codes.
- Although the ice machine has been designed to be serviced in place, in some cases it may be necessary to pull the unit out for service. For that reason do not restrict access to the unit at the front, top and bottom. If a floor is to be installed after the ice machine, shims the thickness of the floor should be installed under the unit to keep the ice machine level with the floor. Also, allow 1/8" (3) clearance on each side of the unit for protruding screw heads.

Installations on a Cement Slab:

Use a Model UC-15IPO or UC-15IP, with built-in drain pump and pump the water to the point of drainage. Drain pump models will pump 12 feet (3.7 m) high.

Installations Over a Crawl Space or Basement:

If there is not enough room behind the ice machine for a drain/waste water receptacle, the drain will have to be below the floor.

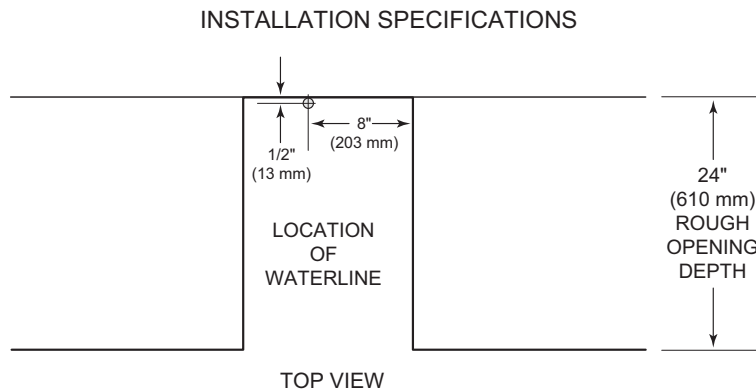

Dimensions in parentheses are in millimeters unless otherwise specified.

INSTALLATION PROCEDURE

1. Prepare the site by following the instructions under Electrical Requirements and Plumbing Requirements found earlier in this section.
2. Remove ice machine from carton
3. Inspect ice machine for damage.
4. Remove literature/warranty packet and drain hose from inside the ice machine.
5. Adjust leveler legs. Refer to Leveling found later in this section.
6. Reverse door if desired. Refer to Reverse the Door Swing found later in this section.
7. **Gravity drain model:** Install drain hose to drain on back of ice machine and route to open site drain. Refer to Plumbing Requirements found earlier in this section.
Pump model: Route drain tubing through drain fitting on the back of the ice machine and install drain hose on drain pump. Route other end of drain tubing to drain site. Refer to Plumbing Requirements found earlier in this section.
8. Use compression fitting to connect the Water Inlet on back of ice machine to the prepared 1/4" ID cold water line. Refer to Plumbing Requirements found earlier in this section.

9. Open the shut-off valve on the water line.
10. Check all visible connections for water leakage. Failure to do so could cause flooding.

⚠ WARNING

IMPROPER WATER SUPPLY AND DRAIN CONNECTIONS CAN RESULT IN PERSONAL INJURY AND SUBSTANTIAL PROPERTY DAMAGE. THESE CONNECTIONS ARE THE RESPONSIBILITY OF THE OWNER/OPERATOR.

11. Connect electrical plug to grounded (three prong), polarized outlet. See Electrical Requirements found earlier in this section.

⚠ WARNING

THE ICE MACHINE MUST BE GROUNDED IN ACCORDANCE WITH NATIONAL AND LOCAL ELECTRICAL CODES. DO NOT USE AN EXTENSION CORD OR ADAPTER.

12. Place ice machine back in position and check leveling again. Make any necessary adjustments.

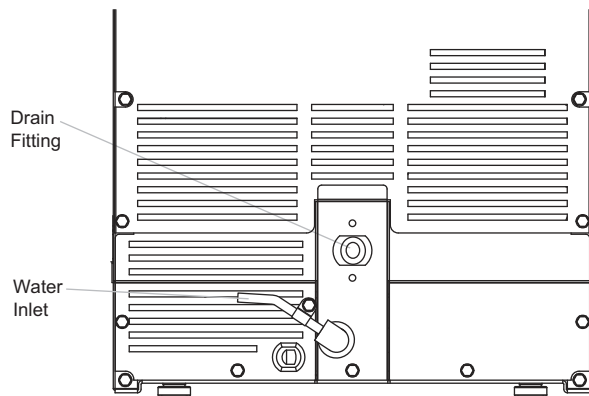

Water Line and Drain fitting at Rear of Unit

(CONTINUED ON NEXT PAGE)



13. Prepare sanitizer solution and sanitize the ice machine according to In Place Cleaning/Sanitizing instructions found in the Installation & Operation manual.
14. Put one gallon (4 L) of cold water into a container that will easily pour under the lifted water shutters. Refer to page 17 to identify water shutters. Open shutters and add one gallon (4 L) of cold water. Watch for proper drainage.
15. Press POWER button.
16. At initial start-up, ice machine will need approximately 30 minutes to freeze ice and up to 5 minutes to harvest the ice. Wait for first cycle of cubes to drop to ensure proper installation.

CAUTION

Do NOT cover the kickplate area

The unit must be allowed to have ventilation through these fins. The door panel may hang in front of the fins, but a decorative kickplate must not cover the fins.

It is possible to paint the kickplate another color. Follow these easy steps:

- Rough up surface to be painted with fine grit sandpaper.
- Wipe with alcohol to ensure it is clean and dry.
- Use an appliance or industrial grade, oil base, high gloss enamel paint.

INSTALLATION SPECIFICATIONS

Gravity Drain Model

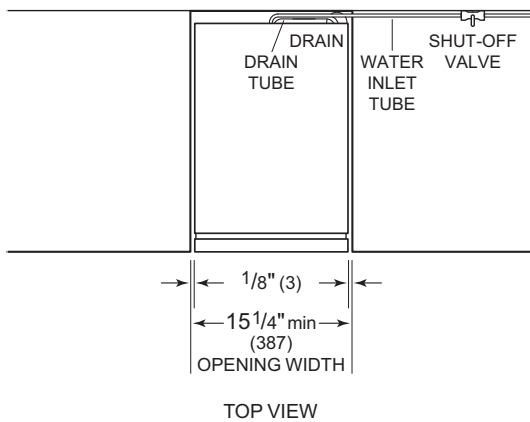

INSTALLATION SPECIFICATIONS

Drain Pump Model

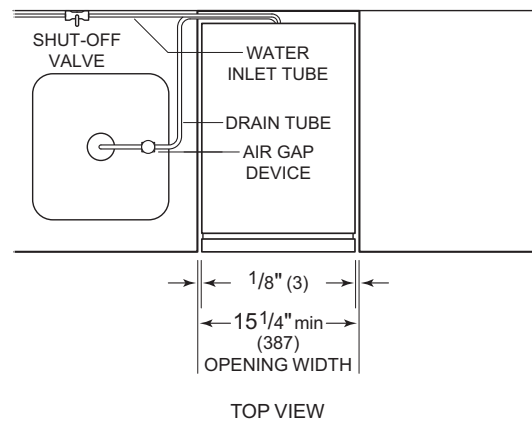

Dimensions in parentheses are in millimeters unless otherwise specified.

LEVELING

1. Adjust the levelers close to desired height.
2. Move the bin into its final position.
3. Level the ice machine to assure that the bin door closes and seals properly. Use a level on top of the bin. Turn the base of each foot as necessary to level the bin. Refer to the illustration below.

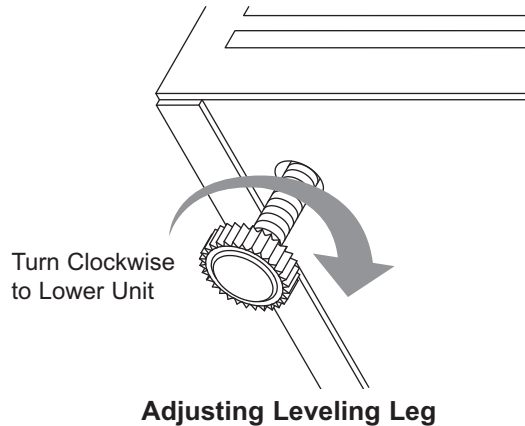

SECURE THE ICE MACHINE

To secure the ice machine, install two #8 x 1/2" flat head screws through each hinge. Refer to the illustration below.

NOTE: If the door swing is to be changed, refer to *Reversing the Door Swing* before securing the unit.

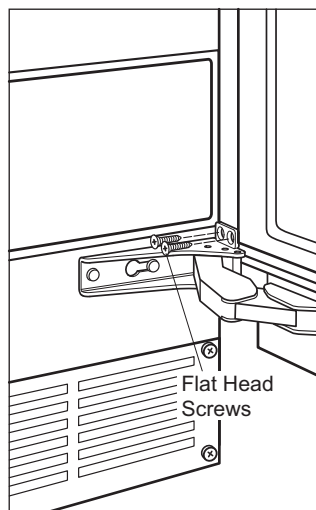

SIDE PANELS

With the Sub-Zero ice machine, the side panels must be securely fastened to the adjacent cabinets and floor.

Panels should be fastened to the floor and walls using 'L' brackets (hardware not provided). To help move the unit into place, rout out an area in the floor so the 'L' bracket will sit flush with the floor level. Brackets and screws are provided for mounting the unit to adjoining cabinets and side panels.

REVERSING THE DOOR SWING

The hinged side of the door may be reversed to the other side if desired. The Sub-Zero ice machine is shipped with the door hinged at the right. The door and hinges are designed for placing the hinges on either the right or the left side of the unit. Moving the hinges to the left in the pre-drilled holes, allows the door to pivot from the left side. Refer to the illustrations below.

NOTE: The plastic molding which covers the top area of the door, packaged with the ice machine, is required for this procedure.

1. To begin, remove the four screws that secure the door hinges to the ice machine. Refer to the illustration below.

NOTE: Remove the shim located between the cabinet and bottom hinge, this shim will transfer to the left side bottom hinge.

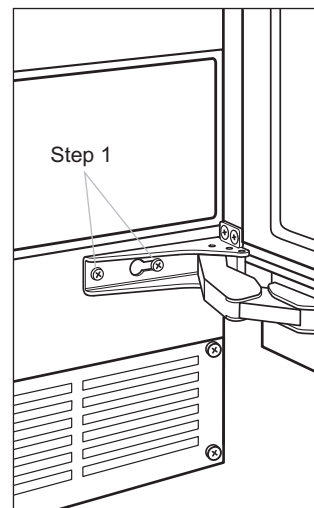

(CONTINUED ON NEXT PAGE)



2. Remove the hinges from the door by removing the four screws (two each hinge) that secure the hinges to the door. Refer to the illustration below.
3. Remove the upper plastic trim piece (right hand configured) from the door by removing the two screws that secure it to the door. Then replace it with left hand trim piece. Refer to illustration below.
4. Transfer the hinges to the left side of the door and re-attach. The upper hinge will need to become the lower hinge and the lower hinge will now need to become the upper. Refer to the illustration below.

6. Remove four screws from the front top rail. Refer to the illustration below.
7. Pivot top rail end for end to expose the two left hand top hinge screw holes and reinstall.

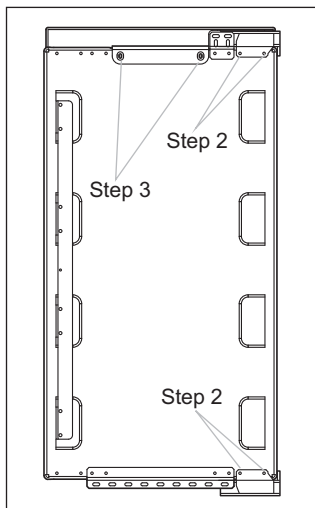

Remove Hinges and Plastic Trim

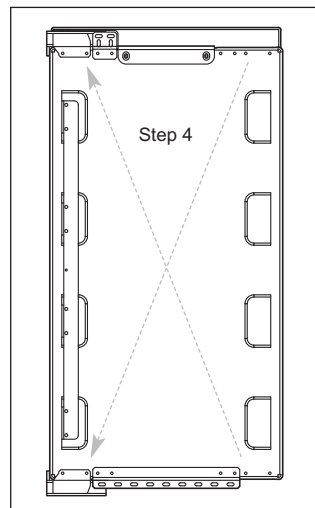

Hinge Transfer

5. Remove the top ice machine cover by removing the two screws along the back of the unit. Refer to the illustration below.

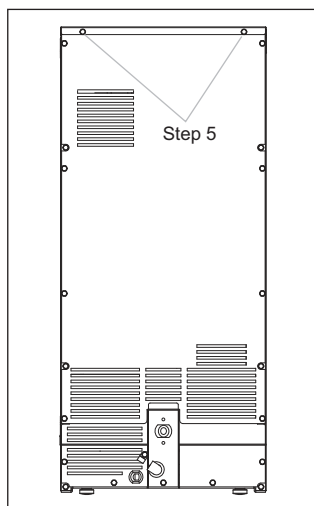

Remove Top Cover

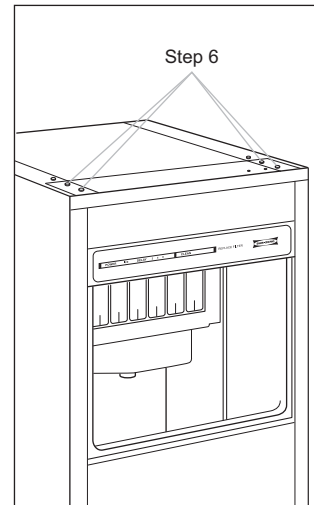

Reversing Top Rail

8. Remove 2 screws from bottom trim plate and slide to cover right hand hinge mounting screw holes and expose left hand hinge mounting screw holes. Refer to illustration below.

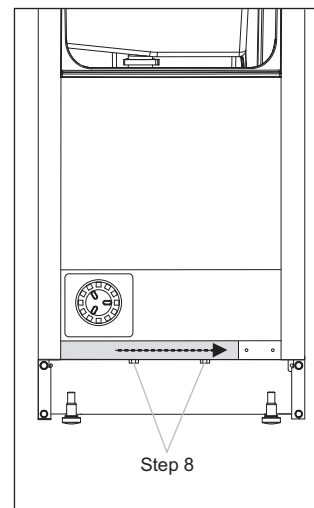

Repositioning Slide Rail

9. Install the door using the left-hand door mounting holes. Install shim removed in step 1 between the hinge and cabinet.
10. Check the operation of the door by opening.

DOOR PANEL INSTALLATION

Be sure of the door panel size and placement before proceeding with the installation. If there are questions, contact the Sub-Zero dealer or cabinet supplier. Instructions regarding sizing of the door panel are provided in the Sub-Zero design guide.

For door handle hardware, a D-style pull centered on the edge opposite the door hinge side is recommended. Screw heads may have to be countersunk to ensure that the hardware does not interfere with the panel fitting flush with the unit door.

DOOR PANEL DIMENSIONS

Door Panel Width – 1/8" (3) reveal	15" (381)
Door Panel Height – 1/8" (3) reveal 4" (102) toe space	30-3/8" (772)
Door Panel Thickness	5/8" (16) min
Door Panel Weight	15 lbs (6.8 kg) max

Dimensions may vary +_ 1/8" (3).

PANEL DESIGN NOTE: Additional panel design information can be found in the Sub-Zero design guide. Check our website at subzero.com.

⚠ CAUTION

Exercise caution when drilling holes for hardware. This is especially critical with inset panels.

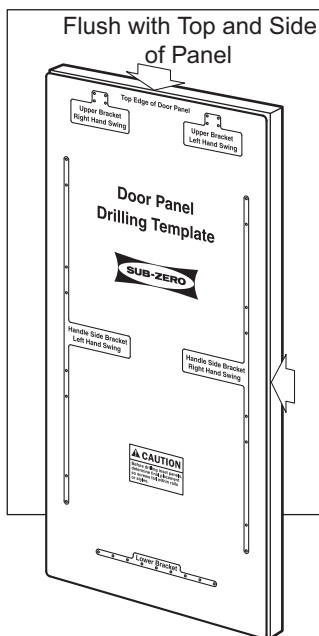

Drill Template Position

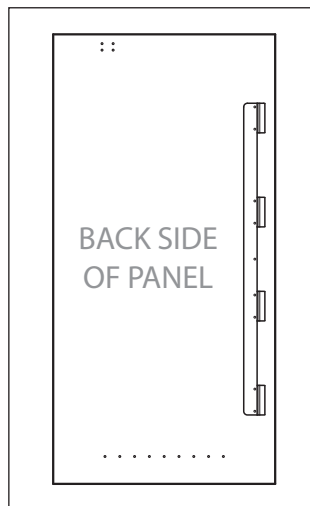

Right-Hand Door Panel

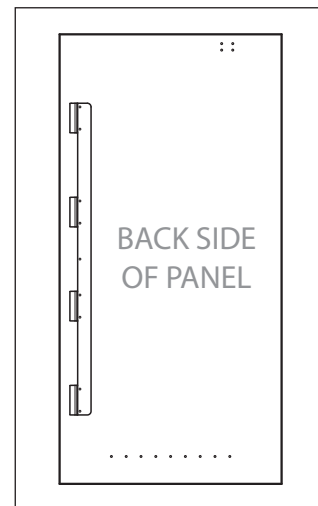

Right-Hand Door Panel

Panel Preparation and Installation

1. Remove the handle side bracket attached to the front of the door and set aside.
2. Place the door panel lying face down on a protected surface to ensure the front is not scratched or damaged.
3. Position the template provided flush with the upper edge of the panel. Be sure to follow the exact location for the RH or LH door position. Refer to the illustration below.

NOTE The door panel is being viewed from the back side in the illustration. The overall size of the panel shown is the minimum size necessary to cover the door of the unit. The exact measurements of the door panel may vary depending on the particular installation being followed.

4. Once the proper position for the hardware has been located, mark the holes, remove template, and drill pilot holes for mounting of the hardware.

NOTE: It is recommended to start the first few holes, positioning the hardware, drilling remaining pilot holes, and securing the mounting brackets with the #8 x 1/2" screws. Refer to the illustrations below.

5. Install the panel onto door by engaging the tabbed bracket to the door first and then sliding the hinge side hardware over the positioning screws. There will be a 1/4" inch adjustment, up and down, side to side, with this hardware.
6. Once the panel is in place, attach the remaining #8 x 1/2" screws to the hinge side mounting bracket and install decorative caps.

⚠ CAUTION

If the reveal on the hinge side of the door panel is less than 1/4", and the panel has a square corner, severe finger pinching or damage to the unit may occur.

90-Degree Door Stop Installation

Certain installations may require the door to stop at 90-degree instead of the full 115-degrees. A door stop pin is supplied with the unit. To install the 90-degree door stop pin (Refer to illustration below):

1. Open door to approximately 80 degrees.
2. Insert 90-degree stop pin down through holes in bottom hinge bracket.
3. Insert 90-degree stop pin up through holes in top hinge bracket.

NOTE: The pins must be inserted until their heads makes contact with the hinge brackets.

4. Check for proper door operation.

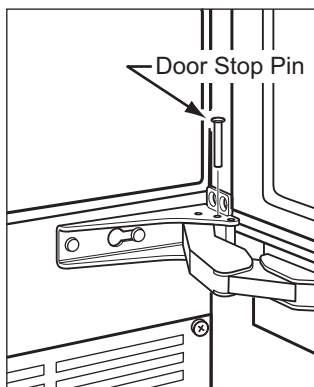

90 Degree Door Stop

Hinge Cover Installation

NOTES:

- Do NOT Install the hinge covers until after installation of the ice machine is complete.
- The 90-degree door stop must be installed prior to installing the hinge covers.
- If the 90-degree stop pins are installed, it will be necessary to remove the knock-outs from the hinge cover opposite the head of the pin.
- Hinges must be free of dirt and grease before attempting to install the hinge covers.

1. Remove backing paper from adhesive pads of upper and lower hinge covers, then adhere covers to top and bottom of each hinge bracket as shown below.
2. The center hinge covers are magnetic. Install them to center of each hinge bracket as shown illustration below.

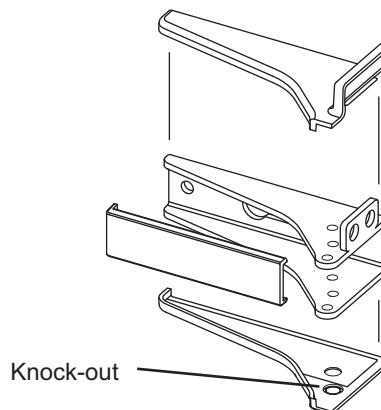

Hinge Cover Installation



SECTION 3

THEORY OF OPERATION

CONTROL PANEL

This page shows the control panel layout (See Figure 3-1) and explains the functions performed at the control panel

POWER Button (Green Indicator Light)

Pressing the POWER button once will activate the ice machine and green POWER light. Pressing the POWER button a second time will de-activate the ice machine.

Automatic Ice Making Light (Blue Indicator Light)

The ICE light is illuminated when the ice machine is in the ice making position. The light is off when the ice machine is in the clean cycle.

DELAY Start

Pressing the DELAY button will initiate a delay cycle. The ice machine will not run until delay time expires.

1. Pressing the button once will illuminate the “2” hour yellow light and initiate a two hour delay period.
2. Pressing the button a second time will illuminate the “4” hour yellow light and initiate a four hour delay period.
3. Pressing the button a third time will illuminate the “8” hour yellow light and initiate an eight hour delay period.
4. Pressing the button a fourth time will cancel the delay cycle.

CLEAN Button (Green Indicator Light)

Pressing the CLEAN button will initiate a clean cycle and de-activate the ICE light. The water system will enter a fill/flush mode for approximately ninety (90) seconds, after which the CLEAN light will flash to indicate the proper time to add ice machine cleaner or sanitizer.

REPLACE FILTER (Red Indicator Light)

When the ice machine completes 8000 freeze/harvest cycles the light will illuminate to indicate the filter needs replacement. Depressing the CLEAN button for 6 seconds will reset the counter and light.

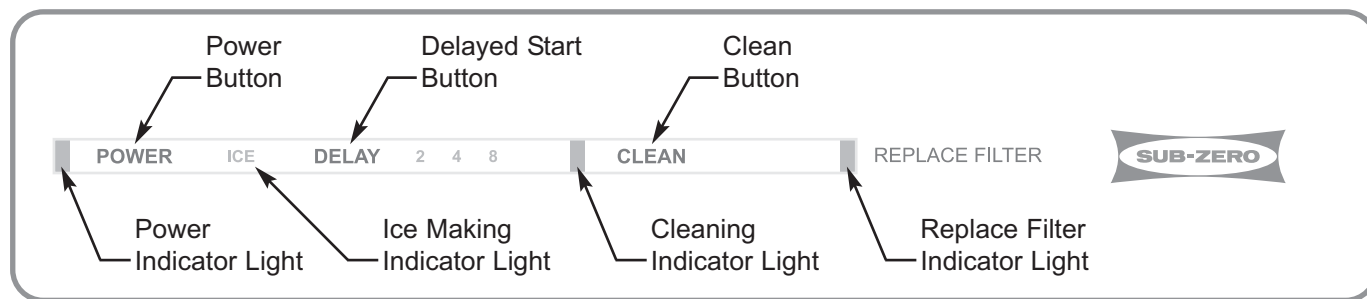

Figure 3-1. Control Panel Layout

OPERATING SYSTEMS

There are three operating systems in the ice machine:

- *Refrigeration System*
- *Water System*
- *Electrical (Electronic Control) System*

Refrigeration System

The following components have been listed in the order of refrigerant flow, with an explanation of their function as part of the refrigeration system. (See Figure 3-2)

- **Compressor:** The compressor creates a high side and low side pressure difference in the refrigeration system by compressing the refrigerant gas, thus raising the pressure and temperature. During the ice making cycle the compressor pushes this high-pressure/high-heat gas to the condenser.
- **Condenser:** The high-pressure/high-heat gas travels through the condenser, where the heat is dissipated by cooler air being drawn over the condenser tubing by the condenser fan. This changes the gas into a high-pressure/warm liquid that then enters the filter-drier.
- **Filter-Drier:** The high-pressure/warm liquid travels through the filter-drier, which removes moisture from the refrigerant before it enters the capillary tube.

- **Capillary Tube:** The warm liquid refrigerant travels through the skinny capillary tube which is attached to the suction tube and wrapped around the base of the accumulator. As the warm liquid refrigerant travels through the capillary tube it gives up heat to the cool vapor refrigerant in the accumulator and to the cool refrigerant gas traveling through the suction line. As the refrigerant in the capillary tube gives up heat, the pressure drops, so it is a low-pressure/cool liquid before it enters the evaporator.
- **Evaporator:** A dramatic pressure drop occurs as the low-pressure/cool liquid refrigerant leaves the small diameter capillary tube and enters the larger diameter evaporator tubing, and the refrigerant begins to vaporize. This vapor travels through the evaporator absorbing heat from the water being sprayed on the evaporator. This cool vapor then enters the accumulator.
- **Accumulator:** Another pressure drop occurs as the cool vaporized refrigerant leaves the evaporator tubing and enters the larger diameter accumulator tubing. Any liquid or vaporized refrigerant that may remain at this point is converted to gas. The capillary tube is wrapped around the accumulator base to give up heat to the refrigerant in the accumulator before it enters the suction line.

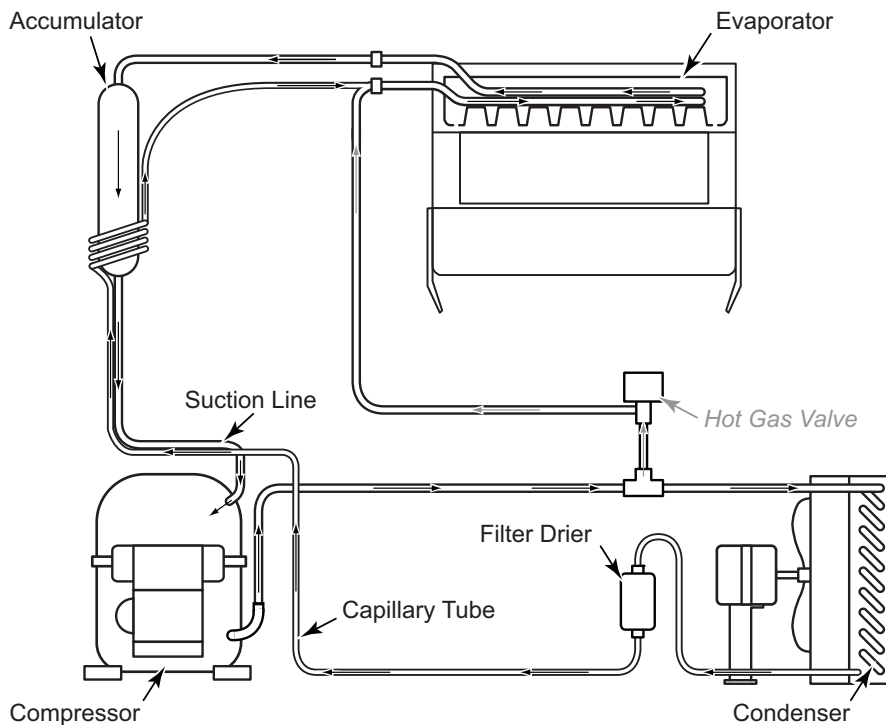

Figure 3-2. Refrigeration System (During Ice Making Cycle)

- **Suction Line:** The cool gas travels through the suction line, absorbing heat from the warm liquid refrigerant traveling through the capillary tube. This assures that it is a luke warm gas before it enters the compressor, where the process begins again.

NOTE: There is an additional component in the ice machine refrigeration system which is used during the harvest cycle, this component is called the hot gas solenoid valve. Its function is described below:

- **Hot Gas Valve:** During a harvest cycle, the hot gas solenoid valve interrupts the flow of high-pressure / high-heat gas from the compressor, diverting it past the condenser, filter-drier and capillary tube, directly to the evaporator. This high-pressure/high-heat gas warms the evaporator so that the ice cubes release from the cube molds.



Water System

The water system provides and recirculates the water for ice production. It also provides a means of drainage. After the ice is produced, the water system flushes the impurities and minerals that were in the water, down the drain. (See Figure 3-3)

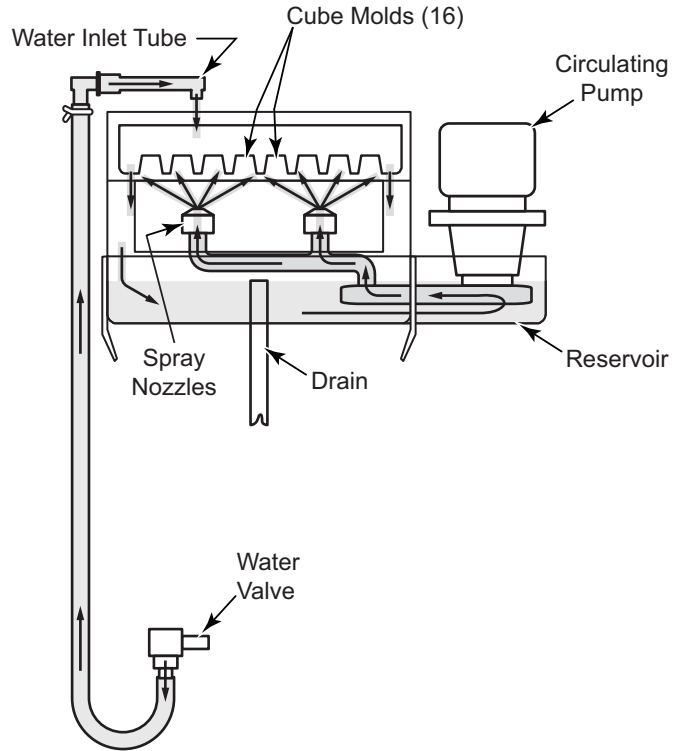

Figure 3-3. Water System (Beginning of Ice Making Cycle)

Electrical (Electronic Control) System

Power for the refrigeration system and the water system in the model UC-15I is provided through the electronic control system. The electronic control system also regulates the operational cycles of the ice machine. Refer to the Wire Diagram at right (See Figure 3-4).

NOTE: The models UC-15IP and UC-15IPO have a drain pump that is powered off of L1, so even when the ice machine is switched OFF, the pump can continue to pump melted ice water to the drain.

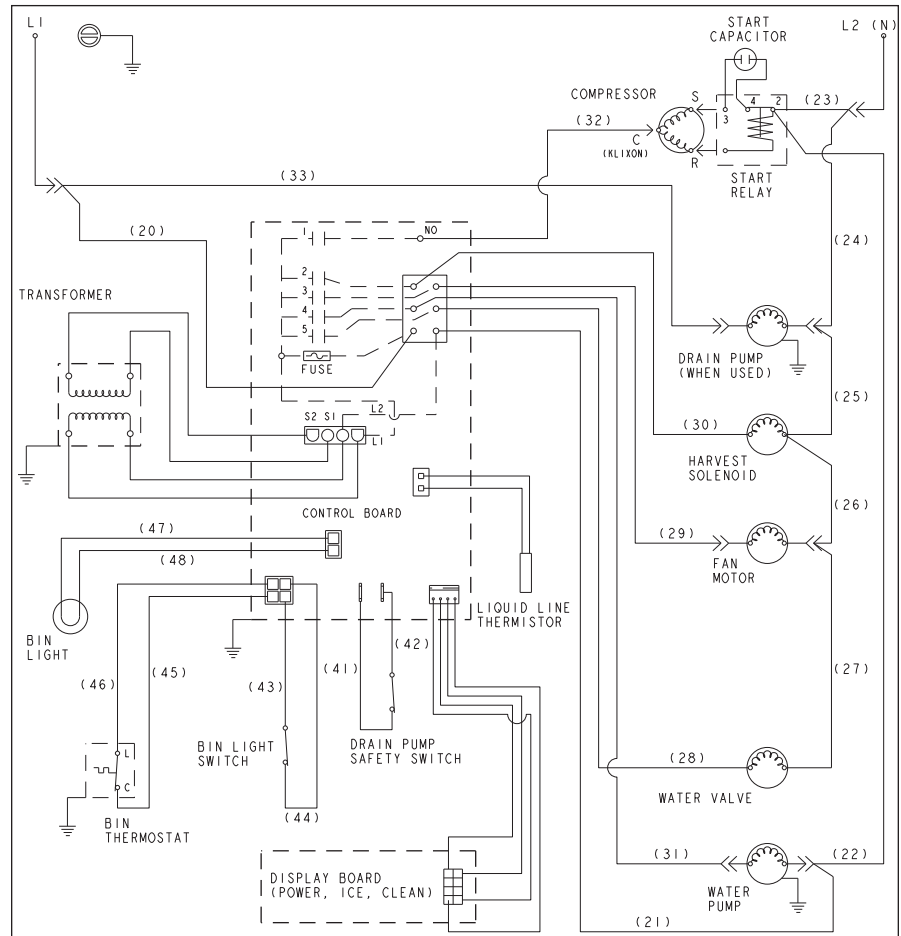

Figure 3-4. Electrical System Wire Diagram



SEQUENCE OF OPERATION

The Sequence of Operation table below provides a quick overview of the different operational events that the ice-maker will experience under normal conditions. Following the table, wire diagrams are used to illustrate which components are energized during each event and additional information is provided. For the freeze cycle and the harvest cycle, diagrams of the water system and refrigeration system are included to help illustrate what is happening inside the ice machine during those cycles.

SEQUENCE OF OPERATION						
SEQUENCE (EVENT)	Water Pump	Water Inlet Valve	Hot Gas (Harvest) Valve	Compressor	Fan Motor	Duration
(RELAY)	(4)	(5)	(2)	(1)	(3)	
Initial Start-up / Start-up after Automatic Shut-off	ON	ON	ON	OFF	OFF	175 Seconds
Refrigeration System Start-up	ON	ON	ON	ON	ON	5 Seconds
Freeze Cycle	ON	OFF	OFF	ON	ON	* Automatically Determined at Beginning of Freeze Cycle
Harvest Cycle	OFF	ON	ON	ON	ON or OFF	** Automatically Determined During Last Minute of Freeze Cycle
Automatic Shut-off	OFF	OFF	OFF	OFF	OFF	Until Bin Thermostat Re-closes

* Maximum freeze cycle allowed by electronic control is one-hundred and twenty (120) minutes.

** Minimum harvest cycle allowed by electronic control is sixty (60) seconds.



Initial Start-up / Start-up after Automatic Shut-off

For 175 seconds (2.9 minutes) the water pump, water inlet valve, and hot-gas (harvest) valve are energized (See Figure 3-5). This is done for the following reasons:

1. The water pump will start to spray water indicating the ice machine is on and this also helps to clear the evaporator/cubes.
2. The water inlet valve opens, filling and overflowing the water trough.
3. The harvest valve opens, helping to equalize the refrigeration system before ice production begin.

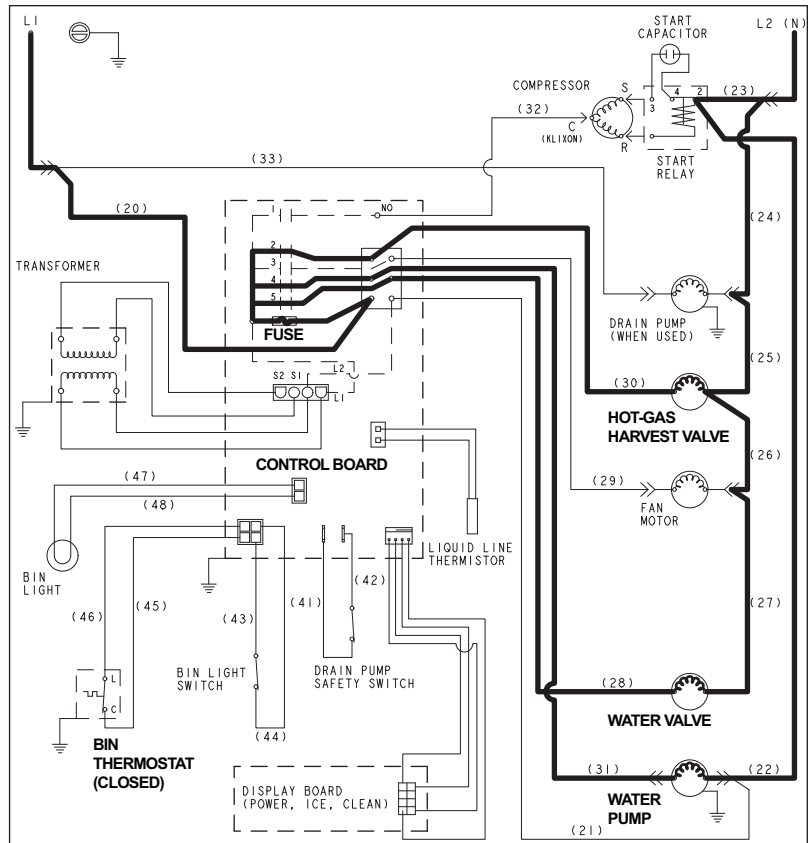

Figure 3-5. Wire Diagram - Initial Start-up

Refrigeration System Start-up

For 5 seconds the compressor, condenser fan motor, water pump, water inlet valve, and hot-gas (harvest) valve are energized (See Figure 3-6). The main reason for leaving the harvest valve open at this time is to start and run the compressor for 5 seconds unloaded. This lengthens the life of the compressor.

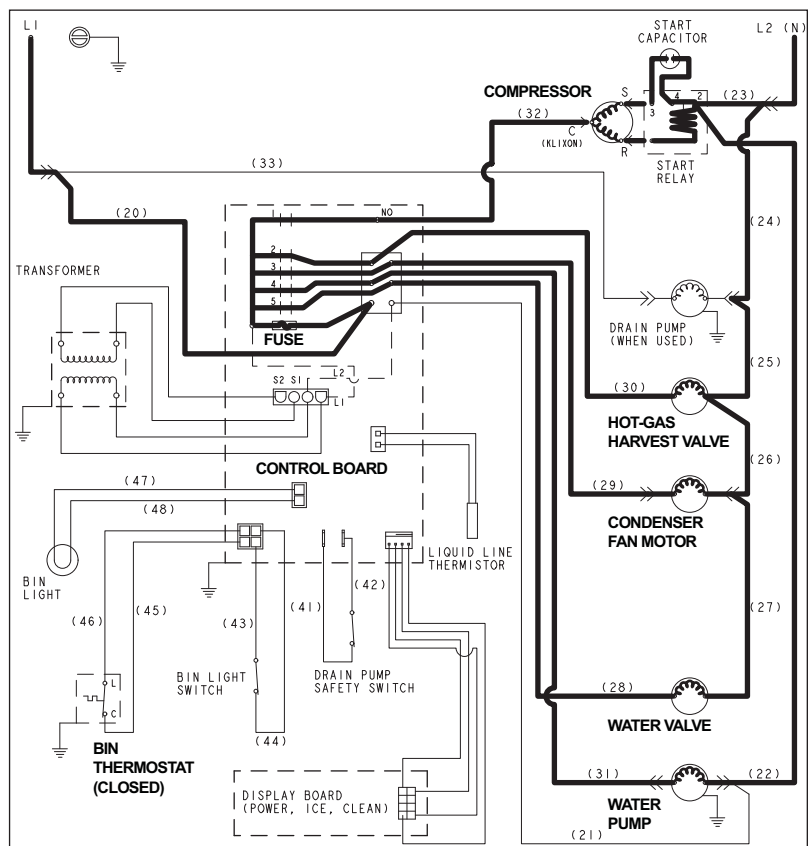

Figure 3-6. Wire Diagram - Refrigeration System Start-up

Freeze (Ice Making) Cycle

During the freeze cycle, only the compressor, condenser fan motor and water pump are energized (See Figure 3-7). The compressor pushes refrigerant through the sealed system, the condenser fan draws air through the condenser, and the circulating pump pushed water through the spray nozzles to the cube molds (See Figure 3-8). The refrigerant running through the evaporator absorbs heat from the water being sprayed into the cube molds and the water freezes. The heat that the refrigerant absorbs from the water is carried in the refrigerant back to the compressor and then through the condenser where the heat is transferred from the refrigerant to the air being drawn through the condenser by the condenser fan. This warm air discharges out through the left side of the kickplate.

As the freeze cycle runs, the electronic control monitors the temperature detected by the thermistor attached to the liquid line/condenser outlet (See Figure 3-7) and calculates freeze time based on the the amount of sub-cooling detected.

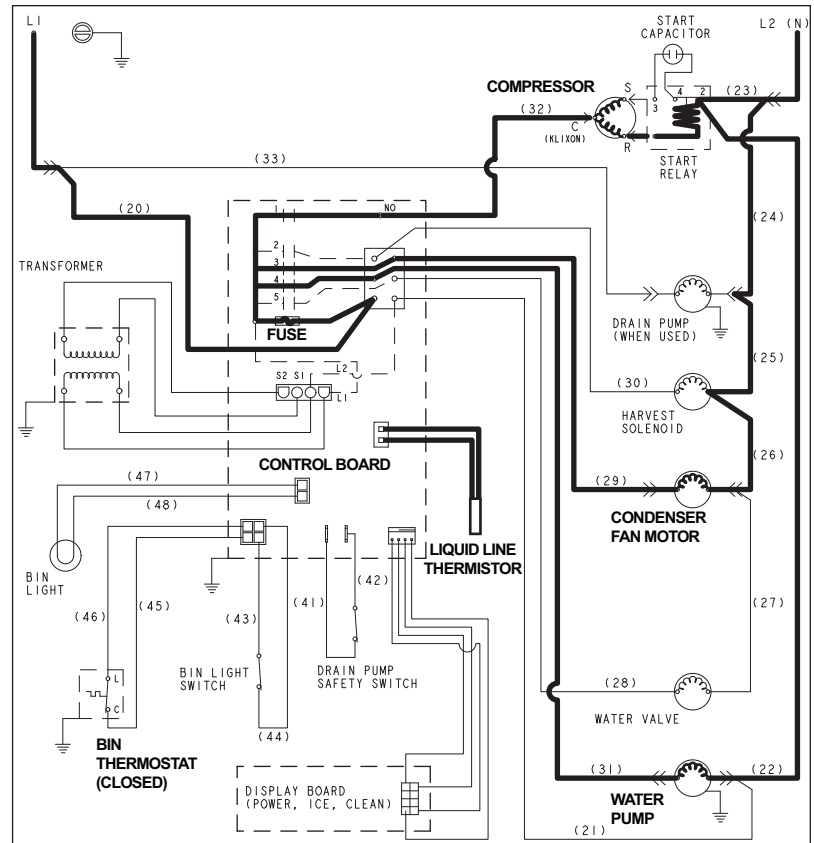

Figure 3-7. Wire Diagram - Freeze (Ice Making) Cycle

NOTE: Maximum freeze cycle is 120 minutes.

NOTE: The Water System During Freeze Cycle - The reservoir is initially filled with approximately two quarts of water, either following a harvest cycle or after an initial start-up. During the ice making cycle, water is taken from the reservoir and sprayed up into the molds where it freezes. However, water containing mineral impurities requires lower temperatures to freeze, so the less pure water falls back into the reservoir while the purer water freezes in the cube molds. This causes the water in the reservoir to become highly concentrated with mineral impurities at the end of the freeze cycle.

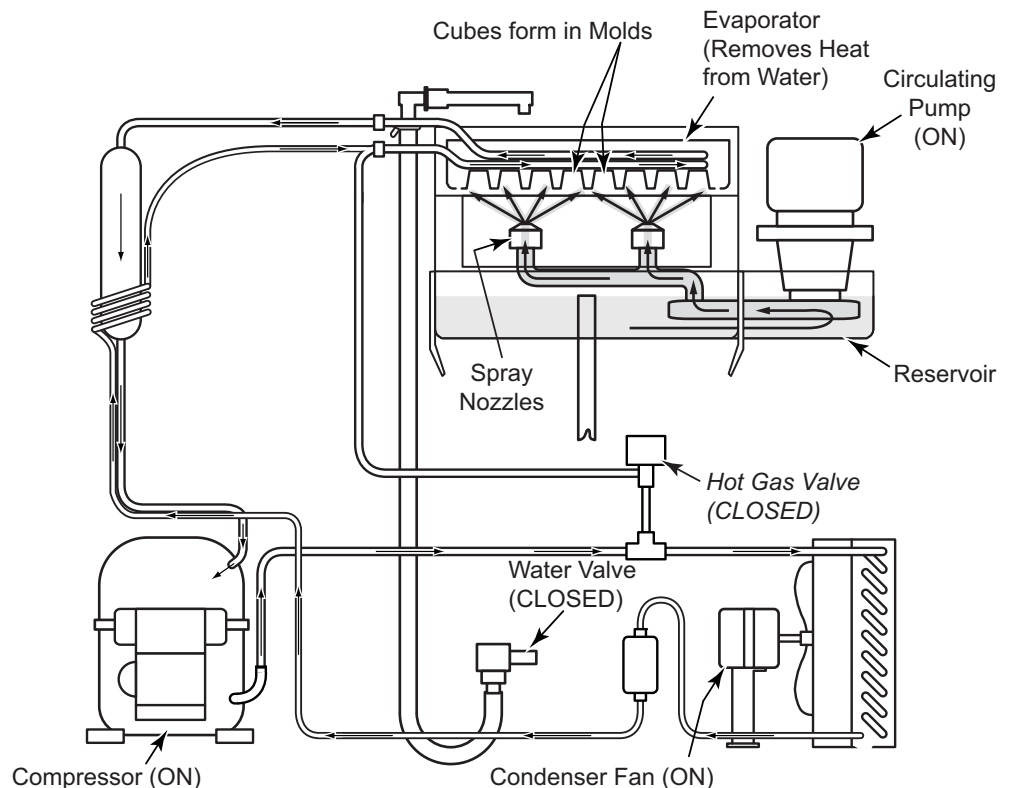

Figure 3-8. Refrigeration and Water System Diagram - Freeze (Ice Making) Cycle



Harvest Cycle

During the last minute of the freeze cycle the electronic control observes the temperature detected by the thermistor on the liquid line (See Figure 3-9), then calculates and controls proper harvest duration.

Once in a harvest cycle, the compressor and condenser fan motor remain energized, with the hot gas valve and water valve also being energized, but the water pump is switched off (See Figure 3-9).

During the harvest cycle the compressor continues pushing refrigerant through the sealed system, but with the hot gas valve open, the high-pressure/high-heat gas from the compressor is diverted to the evaporator instead of the condenser. The water valve is opened to pour water over the top of the evaporator and into the reservoir. With the water pouring over the top of the evaporator and the warm gas running through the evaporator, the ice cubes release from the cube molds and fall into the storage bin. With the water pouring over the top of the evaporator and the warm gas running through the evaporator, the ice cubes release from the cube molds and fall into the storage bin.

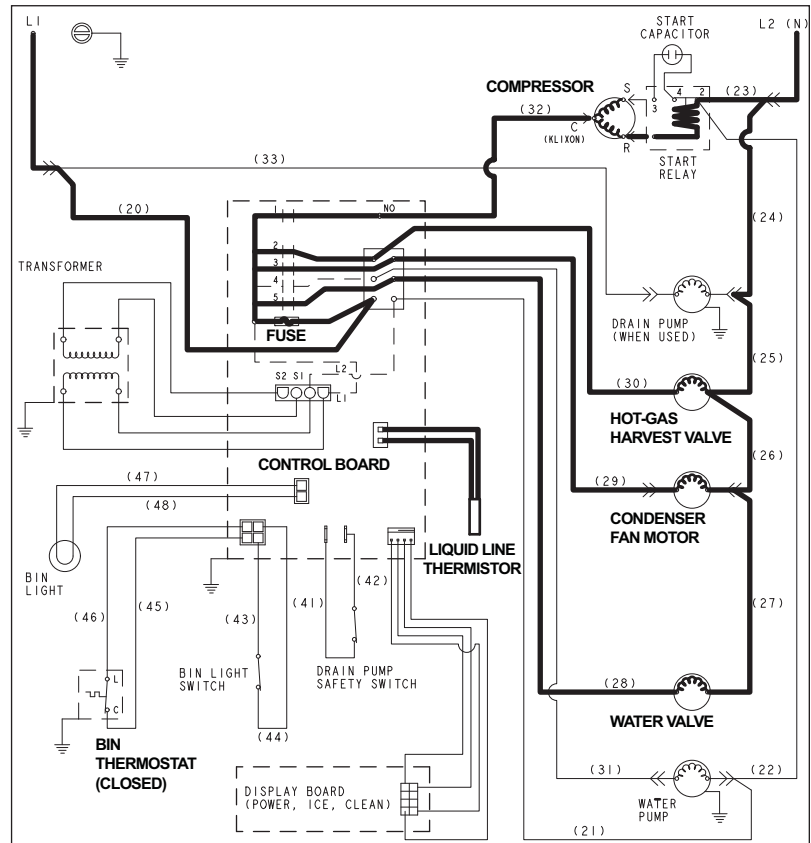

Figure 3-9. Wire Diagram - Harvest Cycle

NOTE: Minimum harvest cycle is 60 seconds.

NOTE: If a problem with the water system is encountered, it is more likely to lead to issues during the harvest cycle before causing any freeze issues.

NOTE: The Water System During Harvest Cycle - Approximately three quarts of water are added to the reservoir during the harvest cycle, over-filling the reservoir by approximately one quart. The extra quart of water rinses the reservoir and goes down the drain carrying the mineral impurities.

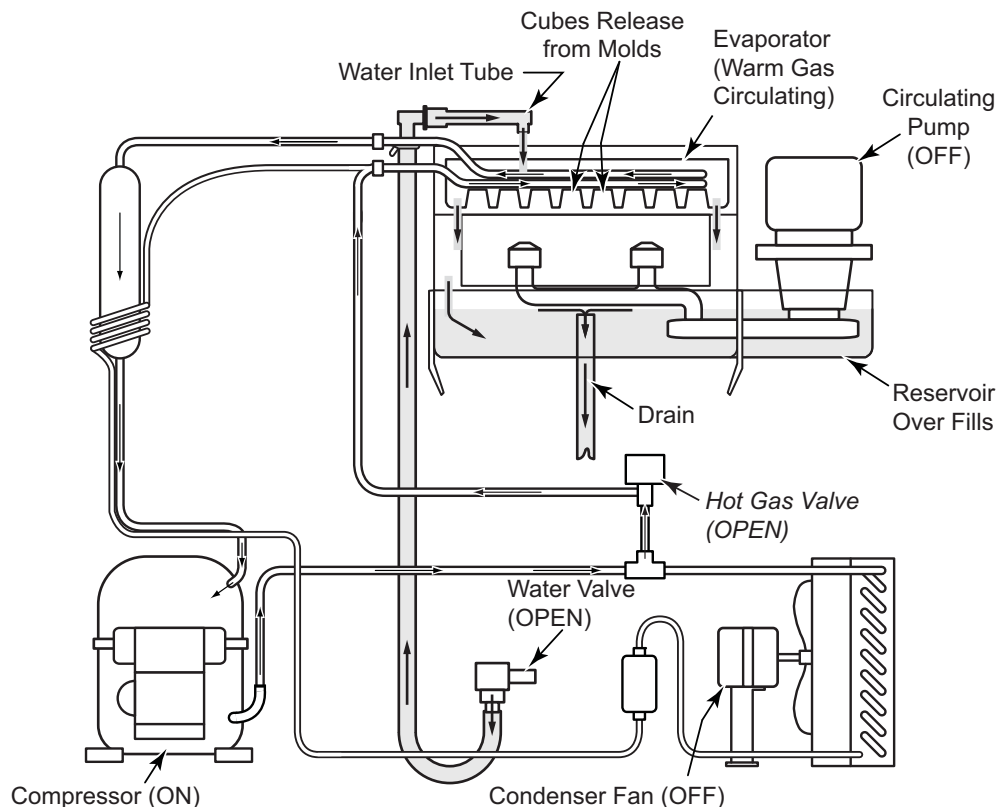

Figure 3-10. Refrigeration and Water System Diagram - Harvest Cycle

Automatic Shut-off

If/when the ice in the bin reaches the bin level thermostat, the thermostat will open, interrupting ice production until enough ice is removed/used or after enough ice melts (See Figure 3-11).

NOTE: The bin level thermostat cut-in is 40°F (4.5°C) and cut-out is 34°F (1.0°C).

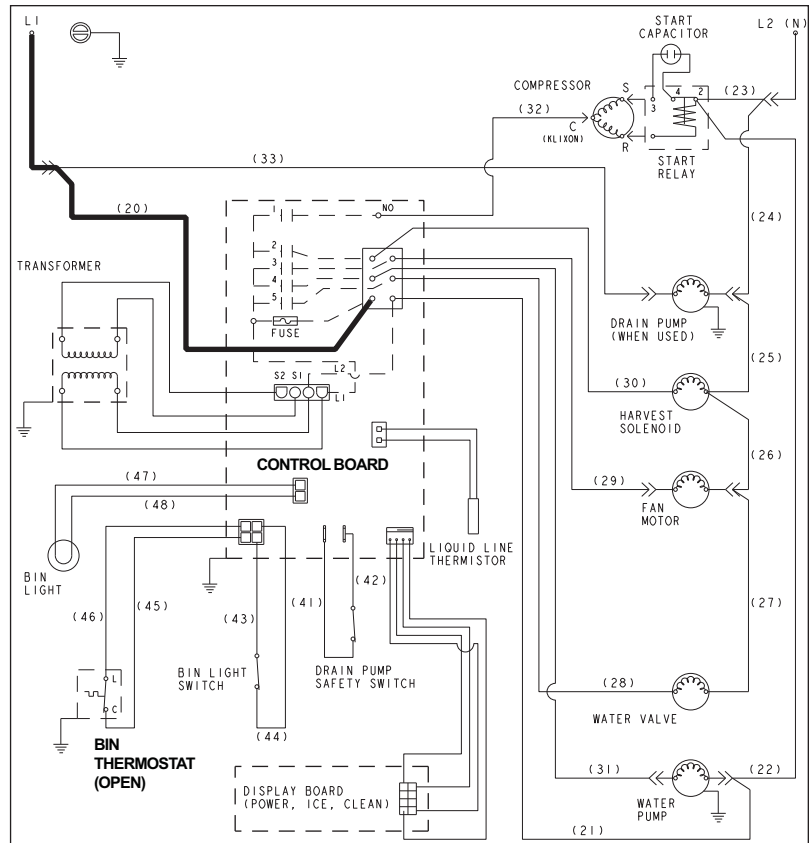

Figure 3-11. Wire Diagram - Automatic Shut-Off

WHAT TO EXPECT FROM THE MODEL UC-15I

The model UC-15I will release a batch of cubes approximately every thirty minutes. At the same time the cubes fall into the bin, water will be filling the reservoir and carrying the mineral impurities down the drain.

Ice

The general shape of the ice cubes is octagonal and tapered toward the top, with the base being approximately 1-1/4" wide, the top being approximately 1" wide and the height being approximately 1-1/8" (See Figure 3-12). When the machine is adjusted properly, there should be approximately 1/4" deep dimple in the base of the cube. (See Cube Weight Adjustment later in this section) The cubes will be wet when fresh, which is normal. The cubes may also develop frost on the outside and look cloudy, this is also normal. (The frost will disappear when liquid is poured over the cubes.)

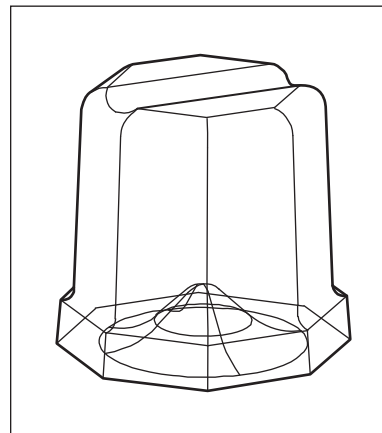

Figure 3-12. Proper Cube Appearance

Storage

The ice storage bin is not refrigerated, but it is insulated, similar to a picnic cooler. If the ice bin were refrigerated, the cubes would freeze together into one large cluster of ice. This would yield ice that is of very poor quality and would be very difficult to remove from the machine.

Run Time

The model UC-15I will continue to operate until the ice builds up high enough to contact the bin thermostat sensor tube, then it will switch OFF (See Figure 3-13). The ice machine remains OFF until ice no longer contacts the bin thermostat bulb holder and the thermostat bulb warms up. The increase in temperature will restart the ice machine.

The amount of time that the model UC-15I will run to replace melted ice (without the door being opened) is approximately four (4) hours per day.

The amount of time that the ice machine will run to replace ice removed during use will depend upon how much ice is removed, how often ice is removed, how clean the ice machine is and how hot the ambient air and water supplied to the ice machine are. An empty ice bin will usually take twelve (12) to twenty-four (24) hours to refill.

NOTE: The models UC-15IP and UC-15IPO have a drain pump that is powered off of L1, so even when the ice machine is switched OFF, the pump can continue to pump melted ice water to the drain.

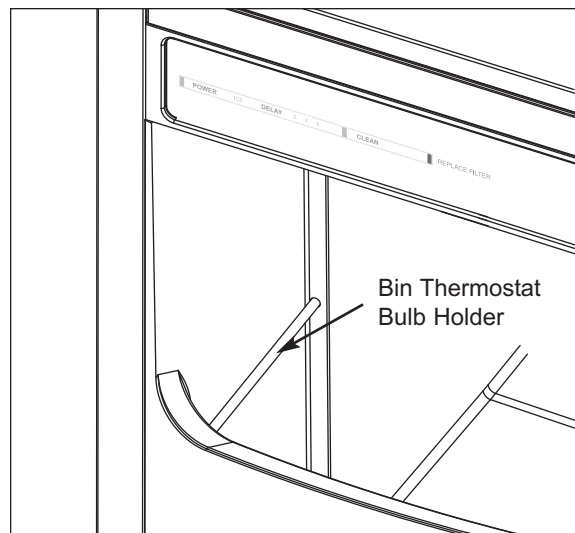

Figure 3-13. Ice Bin Storage Level

Testing and Adjusting the Bin Thermostat

The bin thermostat stops the ice machine when the bin is full. It is preset for normal ambient temperatures and adjustments are usually not required.

Testing the Bin Thermostat - The thermostat is functioning correctly if, when three ice cubes are placed on the thermostat tube for 5 minutes, the ice machine stops. The ice machine should restart 5 minutes after the cubes are removed.

Adjusting the Bin Thermostat - If the ice machine stops before the bin is full or runs after the bin is full, ambient temperatures are probably high or low and the bin thermostat can be adjusted as follows (See Figure 3-14):

⚠ WARNING

POWER IS SUPPLIED TO ICE MACHINE DURING THIS PROCEDURE. AVOID CONTACT WITH THE FAN BLADE AND THE ELECTRICAL CONNECTIONS.

1. To access the thermostat, extract the four kickplate mounting screws and pull kickplate forward.
2. Turn the thermostat shaft clockwise to decrease the level of ice before automatic shut-off; turn counter-clockwise to increase the level of ice before automatic shut-off.
3. Reattach the kickplate.

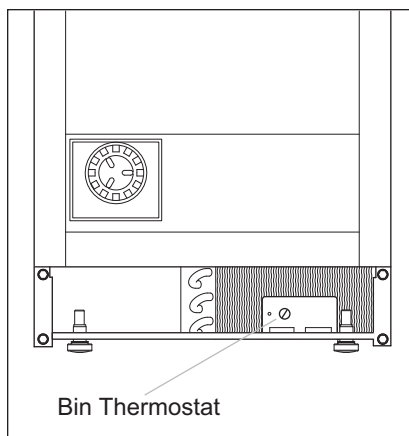

Figure 3-14. Bin Thermostat Adjustment

Cube Weight Adjustment

The ice machine has been programmed to produce the proper cube weight, based on average ambient air and water temperatures. Cube weight can be increased from the factory setting, reducing the amount of dimple in the cube, by adjusting the freeze cycle finish time in one (1) minute increments.

Adjusting Freeze Cycle Finishing Time - To adjust freeze cycle finish time press and hold the POWER button. While holding the POWER button, press and release the CLEAN button once for each additional minute of freeze cycle time desired. (See Figure 3-15)

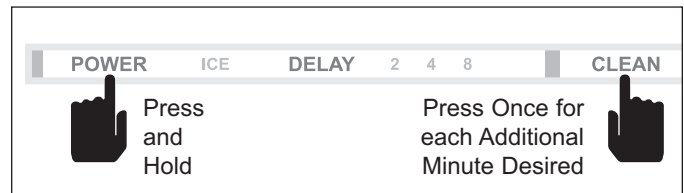

Figure 3-15. Adjusting Freeze Cycle Finish Time

It is recommended to adjust in one (1) minute increments and allow the ice machine to run several freeze/harvest cycles, then inspect the ice cubes. If a heavier cube weight is desired add another minute of freeze time and repeat the process.

NOTE: Five (5) minutes is the maximum additional freeze time that can be added. Pressing the CLEAN button 6 times will reset the finishing time to zero (0) additional minutes.

Checking the Additional Freeze Cycle Time - To check the number of minutes that have been added to the freeze cycle time (See Figure 3-16):

1. Press and hold the POWER button for five (5) seconds.
2. Count number of times the ICE light flashes. Each flash indicates an additional minute of freeze cycle time.

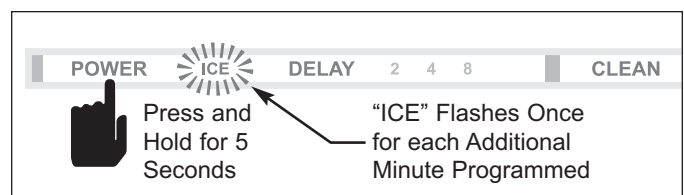

Figure 3-16. Checking for Additional Freeze Cycle Finish Time



SECTION 4

MAINTENANCE, CLEANING AND ADJUSTMENT INFORMATION

ICE MAKER CLEANING & MAINTENANCE

Cleaning and maintenance should be performed a minimum of every six months (see the Recommended Cleaning / Maintenance Schedule below). Basic cleaning and maintenance of the ice machine will increase its reliability, enhance its performance, and help save on water and power consumption.

NOTES:

- Some water conditions will dictate more frequent cleaning of the ice making section, just as some carpets and pets will dictate more frequent cleaning of the condenser.
- To ensure efficient operation, Sub-Zero recommends an annual cleaning be performed by a qualified service technician in which the ice machine is partially disassembled for a more thorough cleaning and sanitizing.

RECOMMENDED CLEANING / MAINTENANCE SCHEDULE

Maintenance Event	Weekly	Semi-Annually (every 6 months)	After Prolonged Shutdown	At Start-up
Clean cabinet exterior	YES	YES	YES	YES
Clean and sanitize interior		YES	YES	YES
Replace water filter*		YES	YES	
Clean condenser coil		YES	YES	
Check ice quality	YES	YES	YES	YES

* Poor water quality may require more frequent cleaning, sanitizing and water filter replacements.

Cleaning the Exterior

Begin cleaning the exterior with mild soap and warm water on a sponge to remove any dust and dirt (this includes the door and door gasket). Wipe dry with a clean, soft cloth. When cleaning stainless steel, use cleaners designed for use with stainless steel products. Never use plain steel wool or abrasive pads, as they will scratch the panels.

2. With a brush attachment, vacuum face of condenser while moving the brush up and down. (See Figure 4-1)

⚠ CAUTION

Do not bend the metal fins of the condenser, doing so will restrict airflow through the condenser, possibly causing mechanical failure of the ice maker.

Cleaning the Condenser

The condenser is located at the right side of the compressor area, behind the kickplate and it looks similar to the radiator on a car. To clean the condenser, follow the directions below:

⚠ WARNING
DISCONNECT ELECTRICAL POWER TO ICE MACHINE AT THE ELECTRICAL SERVICE SWITCHES BEFORE CLEANING THE CONDENSER.

1. Extract four bolts holding kickplate and pull it forward (clean kickplate openings before replacing).

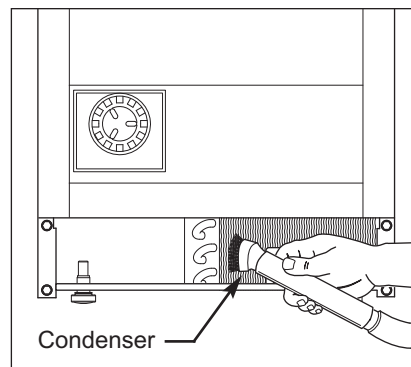

Figure 4-1. Condenser Cleaning

3. After condenser is clean, reattach kickplate with the mounting bolts.

Cleaning and Sanitizing the Interior

An in place cleaning/sanitizing procedure should be performed every six (6) months.

⚠ CAUTION

Damage to the ice machine caused by incorrect chemical usage is not covered by the warranty. Use only Sub-Zero approved ice machine cleaner (part #7013400) and sanitizer (part #7013401).

In Place Cleaning / Sanitizing - This procedure allows semi-annual in place cleaning and sanitizing of the interior. The quality of the homes potable water supply may call for more frequent cleaning intervals.

Use ice machine cleaner (#7013400) to remove lime scale or other mineral deposits. Ice machine sanitizer (#7013400) disinfects and removes algae and slime.

⚠ WARNING

WEAR RUBBER GLOVES AND SAFETY GOGGLES (AND/OR FACE SHIELD) WHEN HANDLING ICE MACHINE CLEANER OR SANITIZER.

NOTE: Before beginning, removed all ice from the bin.

1. Prepare 4 oz (118 ml) of undiluted ice machine cleaner (7013400 only) in a container that will fit easily under lifted paddles (See Figure 4-4).
2. Press CLEAN button (See Figure 4-2). The ice machine will initiate a 2 minute harvest to remove any remaining ice from the evaporator. When that ice falls in the bin, remove it from the bin.

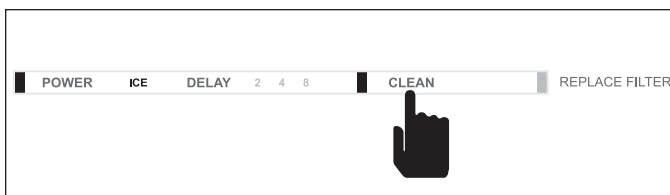

Figure 4-2. Start Clean Cycle, Press “CLEAN”

3. Wait 3 minutes until CLEAN light flashes (See Figure 4-3), then add prepared cleaner by lifting the water paddles and pouring directly into spray area (See Figure 4-4). The ice machine automatically times out a 10 minute cleaning cycle, followed by 8 rinse cycles, then stops. The CLEAN light switches off to indicate the clean cycle is complete. This entire cycle lasts about 30 minutes.

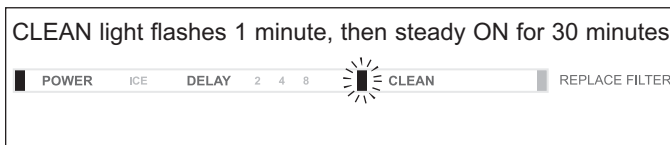

Figure 4-3. Clean Light Flashes = Add Cleaner

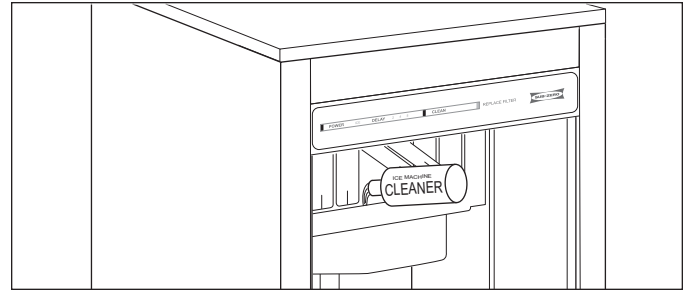

Figure 4-4. Pour Cleaner Into Spray Area

4. Prepare 1 tablespoon (15 ml) of undiluted ice machine sanitizer (7013401 only) in a container that will fit easily under lifted paddles (See Figure 4-7).
5. Press the CLEAN button again, this time to start the sanitize cycle (See Figure 4-5).

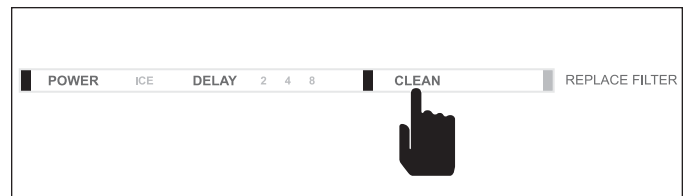

Figure 4-5. Start Sanitize Cycle, Press “CLEAN”

3. Wait 3 minutes until CLEAN light flashes (See Figure 4-6), then add prepared sanitizer by lifting water paddles and pouring directly into spray area (See Figure 4-7). The ice machine automatically times out a 10 minute sanitize cycle, followed by 8 rinse cycles, then stops. The CLEAN light switches off to indicate the sanitize cycle is complete. This entire cycle lasts about 30 minutes.

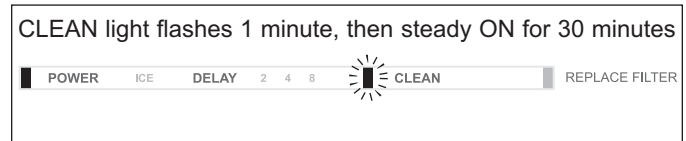

Figure 4-6. Clean Light Flashes = Add Sanitizer

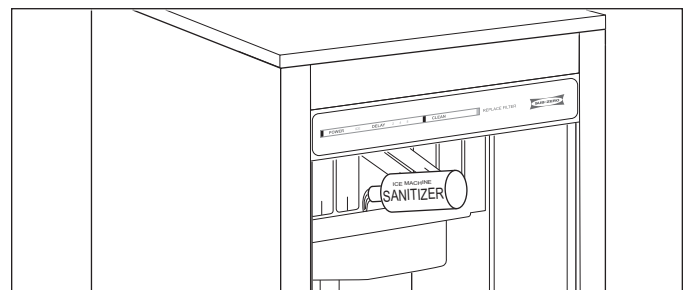

Figure 4-7. Pour Cleaner Into Spray Area

NOTE: The ice machine will automatically continue from previous operational state before clean was initiated. If the unit was in an ice making cycle, it will start making ice again; if it was OFF, it will switch back OFF.



Disassembly Cleaning / Sanitizing - This procedure should be performed by a qualified service technician only, as it entails disassembly of the ice machine for a more thorough cleaning and sanitizing.

1. Perform an in place cleaning as described on page 4-3. The clean cycle takes about 30 minutes. When the clean cycle is complete, disconnect power to the unit and switch off water supply.

⚠ WARNING

DISCONNECT ELECTRIC POWER TO THE ICE MACHINE BEFORE PROCEEDING.

2. Mix 16oz (473 ml) of undiluted ice machine cleaner (7013400 only) with 2 gallons (7.6 liters) of warm water.

NOTE: *Since this mixture will be divided into two equal batches, halving the ingredients mentioned above and mixing them in two separate vessels may be helpful.*

⚠ WARNING

WEAR RUBBER GLOVES AND SAFETY GOGGLES (AND/OR FACE SHIELD) WHEN HANDLING ICE MACHINE CLEANER OR SANITIZER.

⚠ CAUTION

Do not mix Cleaner and Sanitizer solutions together. It is a violation of Federal law to use these solutions in a manner inconsistent with their labeling.

3. After removing all parts as described in Removal of Parts for Cleaning and Sanitizing, take components to a sink for cleaning. Use 1/2 of the cleaner/water mixture to clean all components. The cleaner solution will foam when it contacts lime scale and mineral deposits; once the foaming stops, use a soft-bristle nylon brush, sponge or cloth (**NOT** a wire brush) to carefully clean the parts. Disassemble the spray bar, remove nozzles and inserts and soak for 5 minutes. For heavily scaled parts, soak in solution for 15 – 20 minutes. Rinse all components with clean water.

⚠ CAUTION

Do not immerse the water pump motor in the cleaning or sanitizing solution.

4. While components are soaking, use the other 1/2 of the cleaner/water solution and a nylon brush or cloth to clean inside of ice bin. Clean inside of door, door gasket, bin, top of evaporator and evaporator bucket. Rinse all areas thoroughly with clean water.

5. Mix 1 oz (30 ml) sanitizer with 2 gallons (7.6 liters) of warm water.

NOTE: *Since this mixture will be divided into two equal batches, halving the ingredients mentioned above and mixing them in two separate vessels may be helpful.*

⚠ WARNING

WEAR RUBBER GLOVES AND SAFETY GOGGLES (AND/OR FACE SHIELD) WHEN HANDLING ICE MACHINE CLEANER OR SANITIZER.

⚠ CAUTION

Do not mix Cleaner and Sanitizer solutions together. It is a violation of Federal law to use these solutions in a manner inconsistent with their labeling.

6. Use 1/2 of the sanitizer/water mixture to sanitize all removed components. Use a cloth or sponge to liberally apply the solution to all surfaces of the removed parts or soak the removed parts in the sanitizer/solution. Rinsing is not required.
7. Use the other 1/2 of the sanitizer/water solution and a sponge or cloth to sanitize the inside of ice bin. Sanitize inside of door, door gasket, bin, top of evaporator and evaporator bucket. Rinsing is not required.
8. Replace all removed components.
9. Reapply power and water supply to the ice machine, then perform an in place sanitizing as described on page 4-3.

REMOVAL OF PARTS FOR CLEANING AND SANITIZING

Removal of parts for the recommended annual cleaning and sanitizing should be performed by a qualified service technician only.

Before beginning to remove components, perform an in place cleaning as described on page 4-3. The clean cycle takes about 30 minutes. When the clean cycle is complete, disconnect power to the unit and switch off the water supply. Also read the entire Disassembly Cleaning / Sanitizing procedure on page 4-4.

⚠ WARNING

DISCONNECT ELECTRIC POWER TO THE ICE MACHINE BEFORE PROCEEDING.

Top Cover Removal

To remove the top cover (See Figure 4-8):

1. Extracting two screws along the back of cover.
2. Lift back edge of the top cover up slightly.
3. Pull top cover towards rear of unit until the retaining clips at front disengage from top cover, then lift it off of the unit.

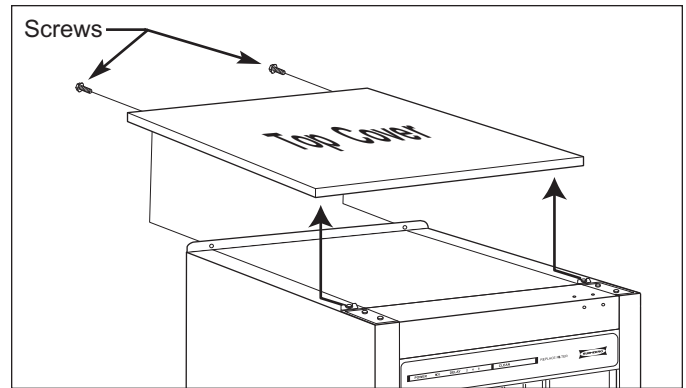

Figure 4-8. Top Cover Removal

Splash Shield Removal

The splash shield is held in place with the same screw that secures the control box cover. To remove the splash shield, the top cover will first need to be removed, then extract the screw and lift the splash shield straight up (See Figure 4-9).

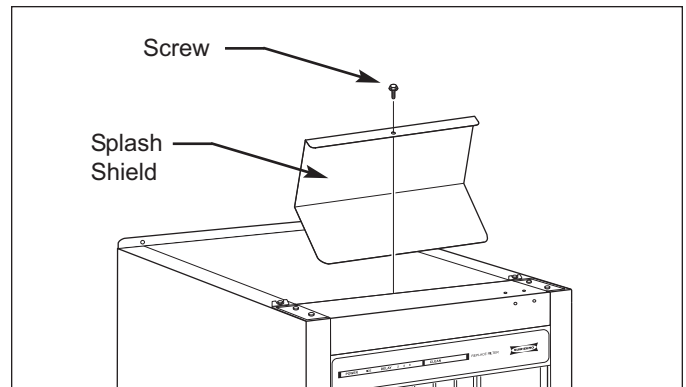

Figure 4-9. Splash Shield Removal

Water Shutter Assembly Removal

The water shutter assembly (consisting of evaporator cover, water paddles and paddle rod) is designed to keep the spraying water from escaping the evaporator/spray bar enclosure. A steel rod which supports the water shutters sits in grooves molded into the evaporator cover.

To remove the water shutter assembly, the top cover will need to be removed first, then (See Figure 4-10):

1. Reach inside bin area and pull evaporator/spray bar enclosure forward approximately 1/2" (13 mm).
2. Grasp both ends of evaporator cover and lift assembly straight up.
3. The rod and paddles can now be pulled from the grooves in the evaporator cover.

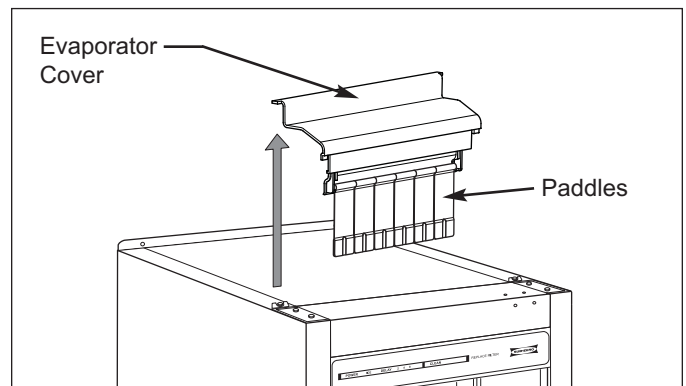

Figure 4-10. Water Shutter Assy Removal

Ice Chute Removal

The ice chute is positioned over the spray nozzles and allows the ice to easily fall into the bin.

To remove the ice chute, grab protruding spray hole on one end, lift up and pull forward out of evaporator/spray bar enclosure (See Figure 4-11)

NOTE: When reinstalling ice chute, it must be firmly positioned over the spray bar, with the front edge inside the water trough. Spray nozzles must align with the spray holes or spray water will fall into the bin.

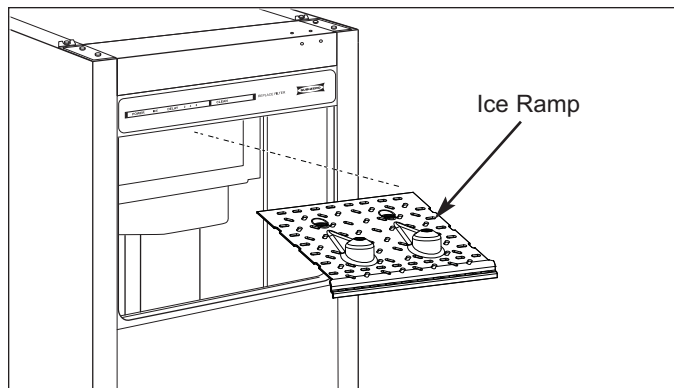

Figure 4-11. Ice Ramp Removal

Water Trough Drain Tube and Standpipe/Overflow Tube Removal

To remove the drain tube and overflow tube (See Figure 4-12):

1. At top of drain tube, disengage tube clamp teeth and remove clamp from tube and water trough nipple.
2. Pull drain tube up out of bin drain.
3. Pull drain tube and standpipe/overflow tube down out of water trough (water in the trough will drain into the bin).
4. Remove standpipe/overflow tube from drain tube by pulling.

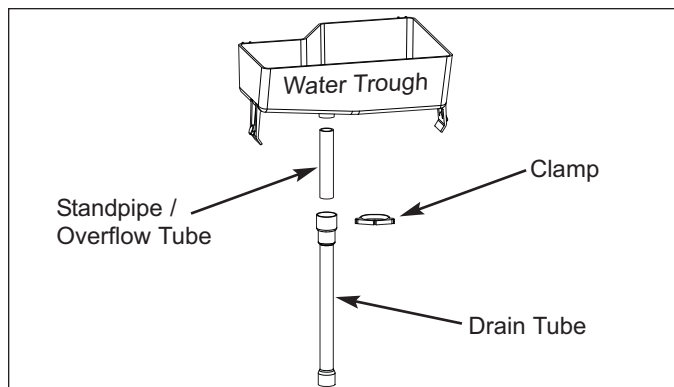

Figure 4-12. Drain Tube & Overflow Tube Removal

Water Trough Removal

To remove the water trough (See Figure 4-13):

1. Depress tabs on right and left side of the water trough.
2. Allow front of trough to drop as you pull forward to disengage the rear pins, then pull from bin.

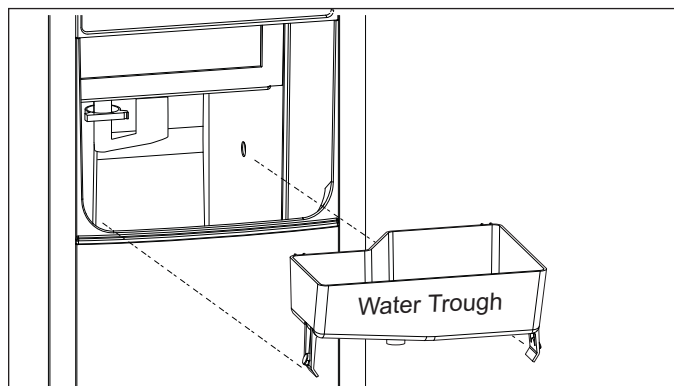

Figure 4-13. Water Trough Removal

Spray Bar Assembly Removal and Disassembly

To remove the spray bar assembly, the ice chute and water trough will need to be removed first, then (See Figure 4-14):

1. At water pump outlet, disengage tube clamp teeth and remove clamp from tube and pump outlet, then pull tube up off of pump outlet.
2. Lift spray bar assembly up and pull forward out of evaporator/spray bar enclosure.
3. With spray bar assembly removed, disengage clamp from tube at spray bar inlet, then pull tube from spray bar.
4. Unscrew water nozzles from spray bar.
5. Pull nozzle inserts out from spray bar outlets.

NOTES:

- *The spray bar also disassembles for easy cleaning.*
- *When reassembling, apply food grade lubricant to spray bar components when necessary.*

Water Pump Removal

To remove the water pump, first remove the ice chute, water trough and spray bar assembly, then (See Figure 4-15):

1. From inside ice bin, extract the mounting screw and eccentric washer securing water pump to upper bin liner.
2. Grasp pump and pull straight down until water pump disengages and electrical connector is visible, then disconnect electrical leads.
3. Extract grounding screw and wire from top of pump and pull pump from bin.

CAUTION

Do not immerse the water pump motor in the cleaning or sanitizing solution.

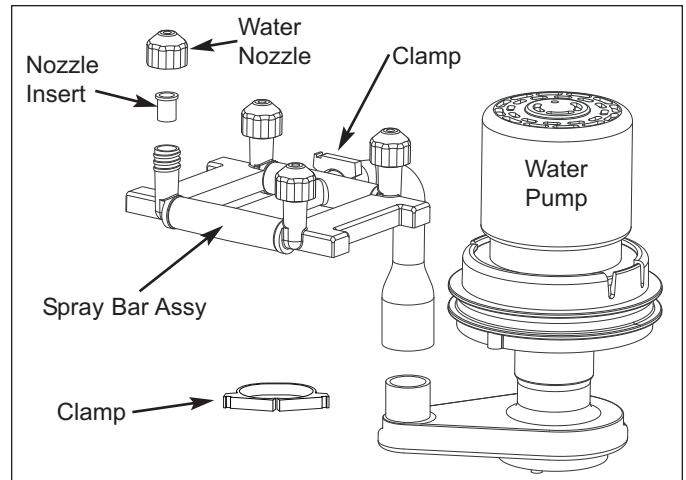

Figure 4-14. Spray Bar Removal & Disassembly

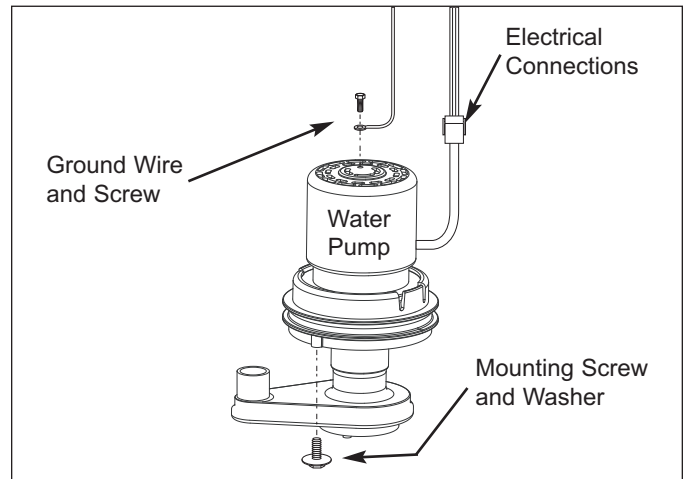

Figure 4-15. Water Pump Removal

REMOVAL FROM SERVICE/ LONG TERM STORAGE / WINTERIZATION

Special precautions must be taken if the ice machine is to be switched off for an extended period of time and/or exposed to ambient temperatures of 32°F (0°C) or below.

Follow the procedure below:

1. To prevent mildew growth, perform an in place cleaning and sanitizing as described on page 4-3.
2. Disconnect the electric power at the circuit breaker or the electric service switch.
3. Turn off the water supply.
4. Remove the water from the water trough.
5. Disconnect and drain the incoming ice-making water line at the rear of the ice machine.
6. Disconnect vinyl hose from water pump and allow to drain.
7. Make sure water is not trapped in any of the water or drain lines. Compressed air can be used to blow out the lines.
8. Mix 0.5 oz (15 ml) of undiluted ice machine sanitizer (7013401 only) with 1 gallons (3.8 liters) of warm water.
9. Put the sanitizer solution into a spray bottle and spray all interior surfaces, but do NOT rinse, allow to air dry.
10. Block the door partially open to provide air exchange and prevent mildew growth.

CAUTION

If water is allowed to remain in the ice machine in freezing temperatures, severe damage to some components could result. Damage of this nature is not covered by the warranty.

WATER FILTER REPLACEMENT

To replace the water filter, incoming water does not need to be turned off. Follow the procedure below (See Figure 4-16):

1. To remove, turn the filter 1/4 turn counterclockwise and it will pop out.
2. To install, push filter in while turning clockwise.

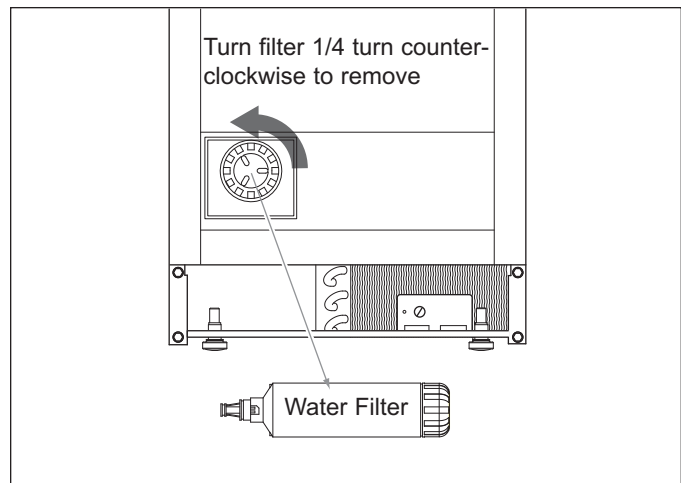

Figure 4-16. Water Filter Removal

ADJUSTMENTS

There are two settings that may be adjusted:

- Cube Weight
- Bin Ice Level

Cube Weight Check and Adjustment

The cube weight can be increased (See Figure 4-17) from the factory setting by adjusting the freeze cycle finish time.

To check for additional finish time (See Figure 4-18):

1. Press and hold the POWER button for five (5) seconds.
2. Count the flashes on the ICE light. The light will flash once for each additional minute of freeze cycle time.

To adjusting finishing time (See Figure 4-19):

1. Press and hold the POWER button.
2. Press and release the CLEAN button once for each additional minute of freeze cycle time desired.
3. Adjust in one (1) minute increments and allow the ice machine to run several freeze/harvest cycles, then inspect the ice cubes. If a heavier cube weight is desired add another minute of freeze time by repeating the process.

NOTE: Five minutes is the maximum additional finish time that can be added. Pressing the CLEAN button 6 times will reset the finishing time to zero (0) additional minutes.

Testing and Adjusting Bin Thermostat

The bin thermostat stops ice production when the bin is full, with ice touching the bin thermostat tube. (See Figure 4-20)

The thermostat is functioning correctly if, when three ice cubes are placed on the thermostat tube for 5 minutes, the ice machine stops. The ice machine should restart 5 minutes after the cubes are removed.

If ice production stops before the bin is full or continues after bin is full, the bin thermostat can be adjusted as follows (See Figure 4-21):

1. Extract four bolts holding kickplate and pull it forward.
2. Turn thermostat adjustment screw counterclockwise to decrease the level of ice; turn clockwise to increase the level of ice.
3. Reassemble the kickplate.

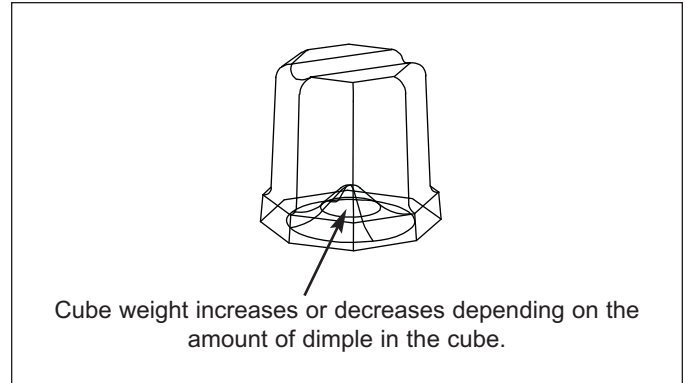

Figure 4-17. Ice Cube Weight

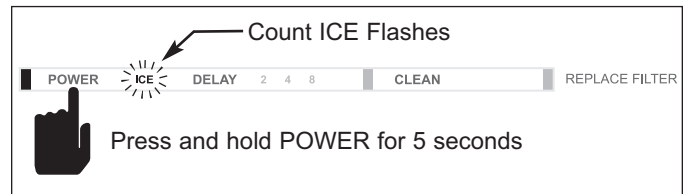

Figure 4-18. Check for Additional Finish Time

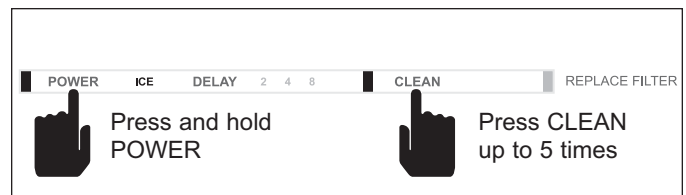

Figure 4-19. Adjust Finish Time / Freeze Cycle

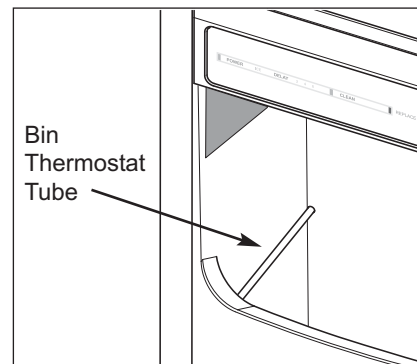

Figure 4-20. Bin Thermostat Tube Location

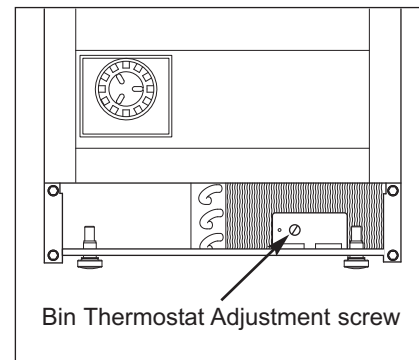

Figure 4-21. Bin Thermostat Adjustment



SECTION 5

COMPONENT ACCESS AND REMOVAL



COMPONENT ACCESS AND REMOVAL

This section explains how to access and remove model UC-15I cosmetic, mechanical and sealed system components. An attempt has been made to arrange these procedures in such a way as to simulate which components would need to be removed first in order to gain access to other components. When following a component removal procedure, it may be necessary to reference another component removal procedure listed earlier in this section.

This section is arranged as follows:

Page:

• Exterior Components	5-3
• Components Below Top Cover (Excluding Sealed System Components)	5-8
• Interior Components	5-10
• Compressor / Condenser Area Components	5-12
• Sealed System Components	5-15

NOTE: Before continuing, please take note of the **WARNINGS** and **CAUTIONS** below.

⚠ WARNING

TO AVOID ELECTRIC SHOCK, POWER TO THE UNIT MUST BE DISCONNECTED WHENEVER ACCESSING AND/OR REMOVING COMPONENTS POWERED BY ELECTRICITY OR COMPONENTS NEAR OTHER ELECTRICAL COMPONENTS.

⚠ CAUTION

- If removing or disconnecting door hinge assemblies, remember they are spring loaded and may recoil quickly when released.
- If working in the compressor area, remember that compressor and tubing may be hot.
- If working on or around the condenser, remember that condenser fins and fan blade are sharp.

Exterior Components

Kickplate Removal

The kickplate is held in place with four screws, two along each side. To remove the kickplate, extract the screws and pull the kickplate forward. (See Figure 5-1)

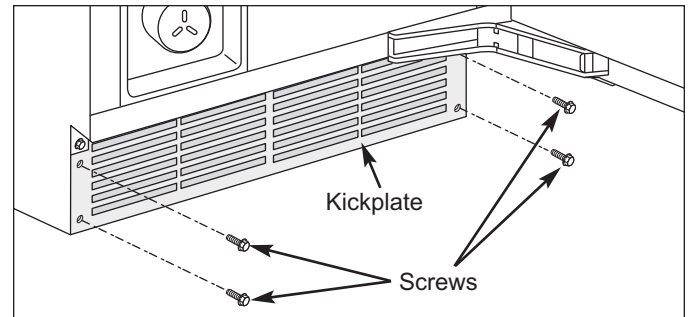

Figure 5-1. Kickplate Removal

Door Panel Removal

The handle-side panel mounting bracket is attached to the back side of the door panel with screws. The tabs of the handle-side bracket then slide into slots in the face of the door. Screws passing through the top and bottom panel mounting brackets, from back to front, into the door panel hold the panel tight to the door.

To remove a door panel (See Figure 5-2):

1. Open the door, then extract the door panel mounting screws from bottom and top brackets.
2. Slide panel towards the hinge side to disengage the handle-side bracket from slots in face of door.

Door Panel Mounting Brackets and Door Hinge Cover Removal

The top and bottom panel mounting brackets, as well as the door hinge cover are attached to the face of the door with screws.

To remove a panel bracket or door hinge cover, the door panel will need to be removed first. Then, extract the bracket or hinge cover mounting screws and pull the bracket or hinge cover from the face of the door (See Figure 5-2).

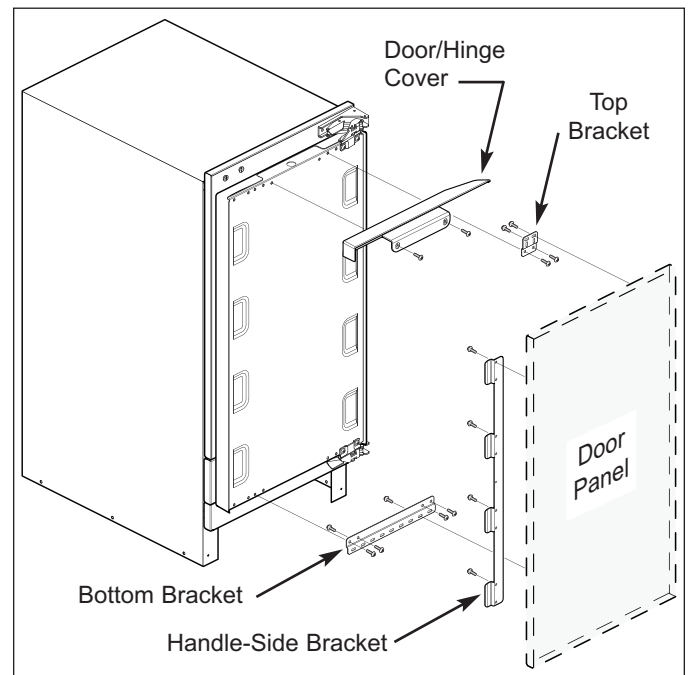

Figure 5-2. Panel Mount Hardware & Upper Door/Hinge Cover Removal

Door Gasket Removal

The door gasket has a rib on its back side that fits into a channel in the door liner.

To remove the door gasket, open the door and pull the gasket from the channel in the door liner (See Figure 5-3).

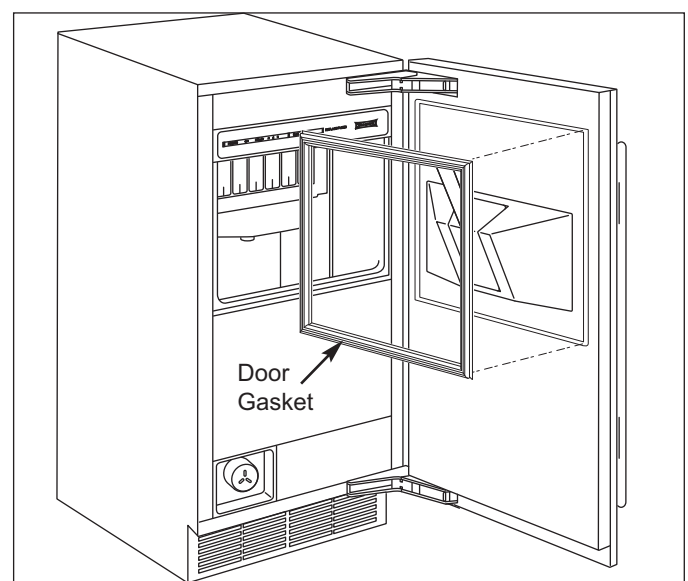

Figure 5-3. Door Gasket Removal

Door Assembly Removal

The door assembly is attached to the top and bottom hinge assemblies with screws passing through the hinge assemblies, from front to back, into the face of the door.

To remove the door (See Figure 5-4):

1. Remove the door panel.
2. Extract the door mounting screws from the bottom and top hinge assemblies, then pull the door from the unit.

NOTE: To remove the door with the hinges, see Hinge Assembly Removal instructions below, following steps 3 through 5 for both hinges.

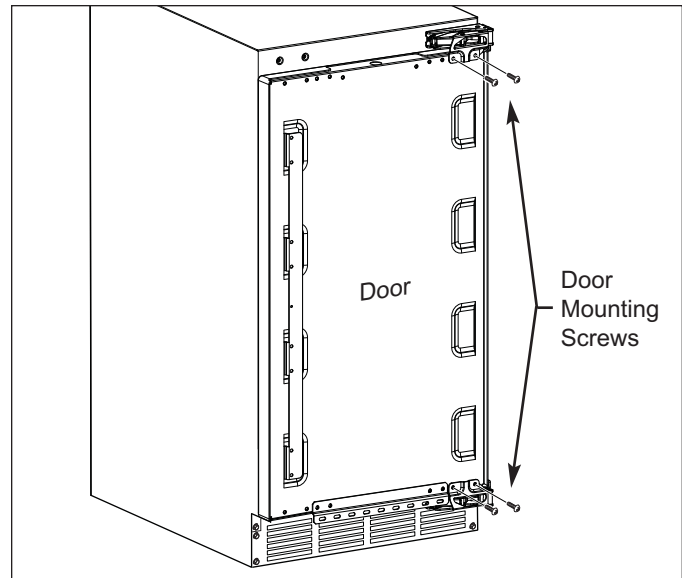

Figure 5-4. Door Removal

Hinge Assembly Removal

The hinges are secured to the unit with screws that pass through the hinge assembly, a hinge spacer behind each hinge, and into the cabinet frame.

To remove a door hinge assembly (See Figure 5-5):

1. Remove the door panel.
2. Remove the door.
3. Extract outer most hinge screw from hinge bracket.
4. Loosen the screw at keyhole slot of hinge bracket.
5. Slide hinge assembly toward hinge side of unit until screw head clears the keyhole slot, then pull hinge assembly from the unit.

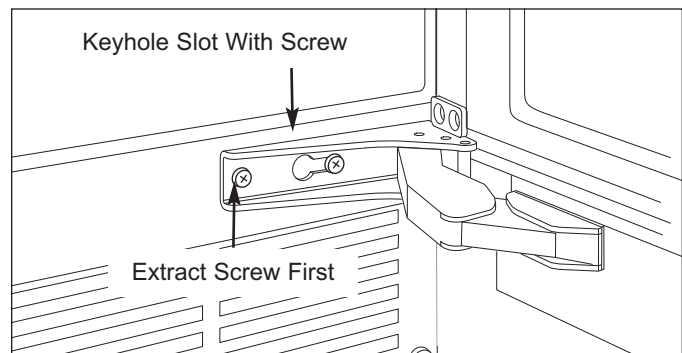

**Figure 5-5. Hinge Removal
Bottom Hinge Shown**

Trim Plate / Slide Cover Bracket Removal

The trim plate / slide cover bracket is held in place by screws passing through the front flanges of the side panels into the bracket. There are also screws that pass up through the trim plate and slide cover into the filter panel.

To remove the trim plate and slide cover bracket, the kickplate, door and lower hinge assembly must be removed first, then (See Figure 5-6):

1. Extract the screws that hold the bracket to the side panels and filter panel.
2. Lean the bracket forward, then pull the bracket from behind the side panels and remove from unit.

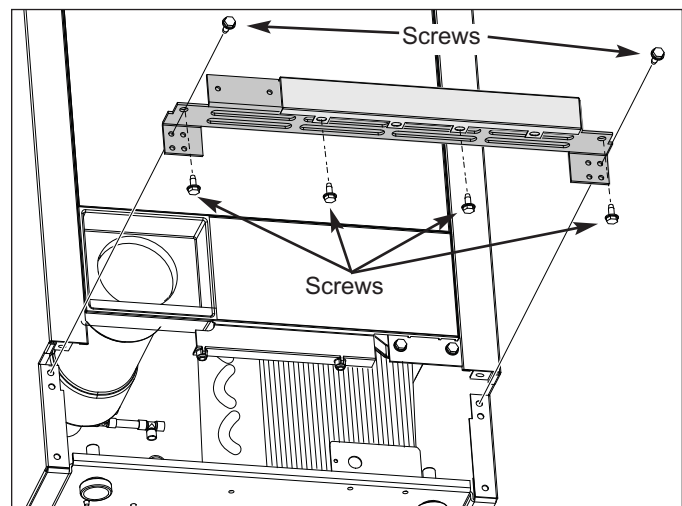

Figure 5-6. Trim Plate / Slide Cover Removal

Water Filter Panel Removal

The water filter panel is captivated between the trim plate / slide cover bracket and the front of the cabinet body.

To remove the water filter panel, first remove the kick-plate, door, lower hinge assembly and trim plate and slide cover bracket. Then, (See Figure 5-7):

1. Extract the water filter
2. Slide filter panel down and pull it away from unit.

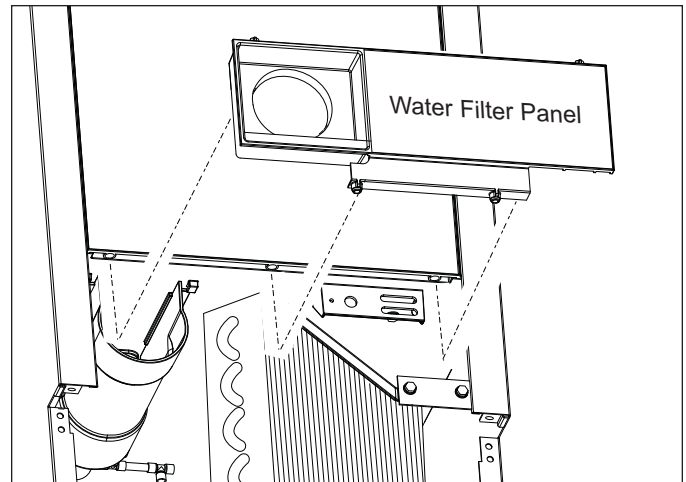

Figure 5-7. Water Filter Panel Removal

Top Cover Removal

To remove the top cover (See Figure 5-8):

1. Extracting two screws along the back of cover.
2. Lift back edge of the top cover up slightly.
3. Pull top cover towards rear of unit until the retaining clips at front disengage from top cover, then lift it off of the unit.

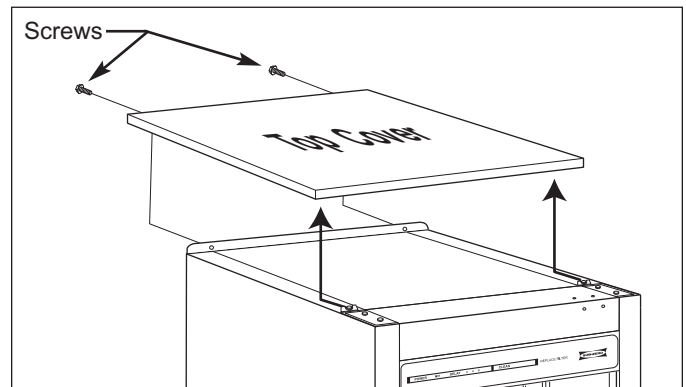

Figure 5-8. Top Cover Removal

Upper Back Panel Removal

The upper back panel is attached to the rear of the unit with screws around its perimeter.

To remove the upper back panel, remove the unit's top cover first, then extract the screws securing the back panel to the rear of the unit (See Figure 5-9).

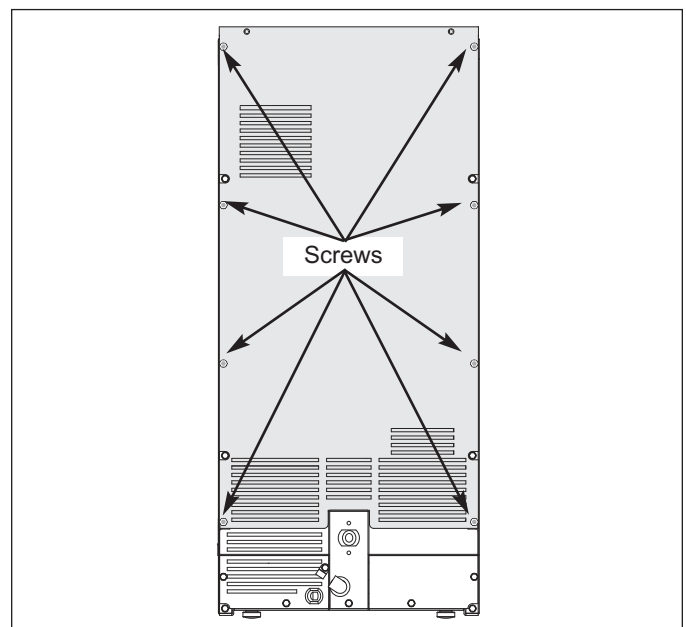

Figure 5-9. Upper Back Panel Removal

Lower Back Utility Panel Removal

The lower back utility panel is attached to the rear of the unit with screws.

NOTES:

- To fully remove the lower utility panel, the water inlet tube will need to be disconnected from the house supply line.
- The power cord passes through a strain relief bushing in the utility panel. These directions allow for the power cord to remain attached to the utility panel.

To remove the utility panel (See Figures 5-10 & 5-11):

1. Pull the drain hose from the drain tube.
2. Turn the drain tube until its tabs can be pushed into the compressor area.
3. Extract the screw securing the water inlet line tube clamp to the lower utility panel.
4. Extract the utility panel mounting screws.
5. Pull lower utility panel away from unit while feeding water inlet tube through hole in panel; stop when power cord electrical connections become taught.
6. Disconnect power cord electrical leads from the unit wire harness.
7. Extract the power cord grounding screw and pull lower utility panel from back of unit.

Power Cord Removal

The power cord passes through a strain relief bushing in the lower utility panel.

To remove the power cord (See Figure 5-11):

1. Extract the screw securing the water inlet line tube clamp to the utility panel, then extract the panel mounting screws.
2. Pull lower utility panel away from unit while feeding water inlet line through hole in panel; stop when the power cord electrical connections become taught.
3. Disconnect power cord electrical leads from the unit wire harness and extract the power cord grounding screw.
4. With a pliers, squeeze the strain relief bushing together at the back side of the utility panel while pushing the bushing through the hole in the panel.

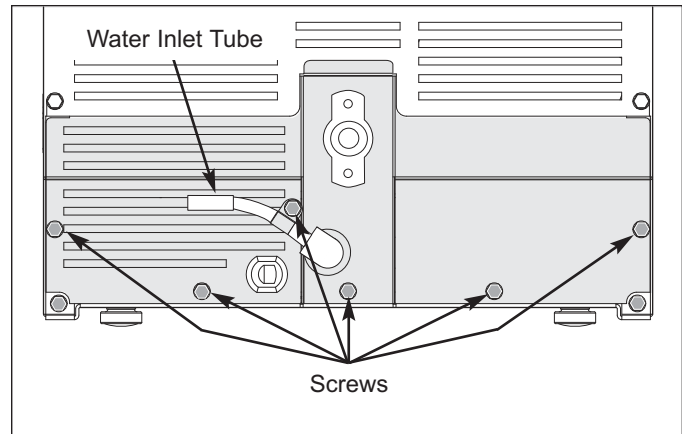

Figure 5-10. Lower Rear Panel Removal

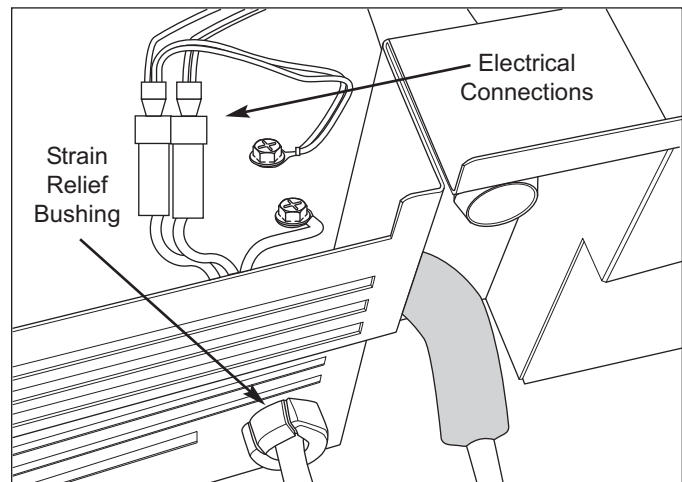

Figure 5-11. Power Cord Removal

Front Top Rail Removal

The front top rail slides down behind the left and right outer side panels and is secured with screws at each end that pass down through the rail into the cabinet frame.

To remove the front top rail, the door, upper hinge assembly and top cover must be removed first, then (See Figure 5-12):

1. Extract the screws from each end of the top rail.
2. Grasp the top rail from both sides and pull upward.

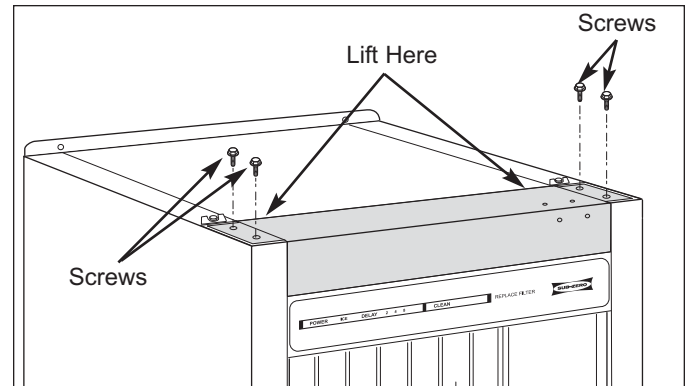

Figure 5-12. Front Trim Rail Removal

Components Below Top Cover

The control box, water shutter assembly and splash shield are all accessible only after removing the unit's top cover. The control box contains the user interface board, main control board, transformer, bin light fixture and switch.

Splash Shield Removal

The splash shield is held in place with the same screw that secures the control box cover. To remove the splash shield, the top cover will first need to be removed, then extract the screw and lift the splash shield straight up (See Figure 5-13):

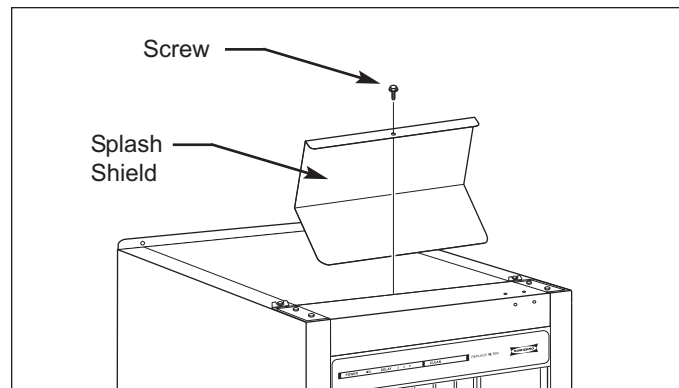

Figure 5-13. Splash Shield Removal

Water Shutter Assembly Removal

The water shutter assembly (consisting of evaporator cover, water paddles and paddle rod) is designed to keep the spraying water from escaping the evaporator/spray bar enclosure. A steel rod which supports the water shutters sits in grooves molded into the evaporator cover.

To remove the water shutter assembly, the top cover will need to be removed first, then (See Figure 5-14):

1. Reach inside bin area and pull evaporator/spray bar enclosure forward approximately 1/2" (13 mm).
2. Grasp both ends of evaporator cover and lift assembly straight up.
3. The rod and paddles can now be pulled from the grooves in the evaporator cover.

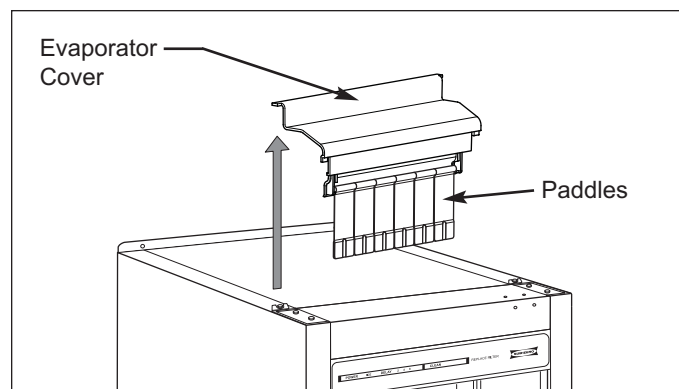

Figure 5-14. Water Shutter Assy Removal

Control Box Cover Removal

The control box cover is concealed by the unit's top cover. It is held in place with its front edge under the front trim rail and a screw that passes through the splash shield and the cover, into the back mounting hole in the control box.

To remove the control box cover, the unit's top cover must first be removed, then (See Figure 5-15):

1. Extract control box cover mounting screw.
2. Lift back of cover up slightly, pull toward rear of unit, then lift it up off of control box.

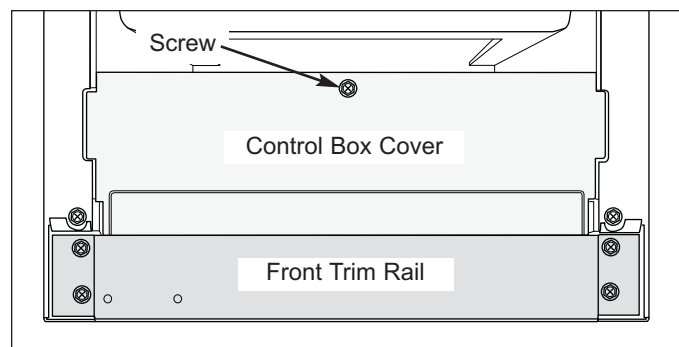

Figure 5-15. Control Box Cover Removal

User Interface Board Removal

To remove the user interface board, the top cover and control box cover must be removed first, then (See Figure 5-16):

1. Disconnect all electrical leads from user interface board at Molex connector.
2. With one hand, flex the front panel away from user interface board; with other hand, pull board upward until user interface board is free from retainer clips.

Filter Indicator Removal

To remove the filter indicator, the top cover and control box cover must be removed first, then (See Figure 5-17):

1. Disconnect indicator leads from main control board.
2. Pull filter indicator out of its installation position and up out of control box.

Transformer Removal

To remove the transformer, the top cover and control box cover must be removed first, then (See Figure 5-17):

1. Disconnect ground wire from the transformer wire harness and transformer leads from main board.
2. Extract transformer mounting screws and lift transformer from control box.

Light Fixture Removal

To remove the light fixture, the top cover and control box cover must be removed first, then (See Figure 5-18):

1. Disconnect wire leads from main control board.
2. Pinch top of fixture while lifting it from the bottom of control box.

Main Control Board Removal

To remove the main control board, the top cover and control box cover must be removed first, then (See Figure 5-18):

1. Disconnect all wires from the control board.
2. Extract the control board mounting screws and lift board from bottom of control box.

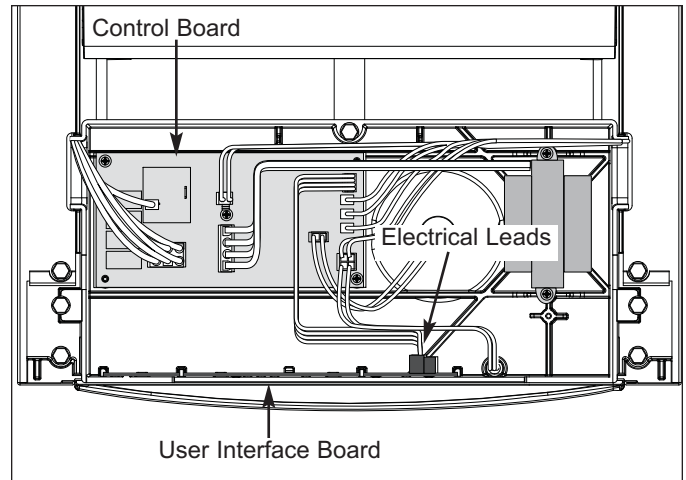

Figure 5-16. Control Box Components

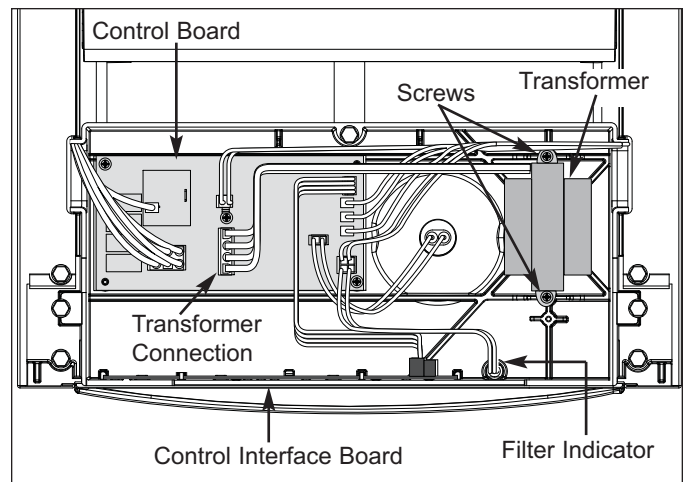

Figure 5-17. Control Box Components

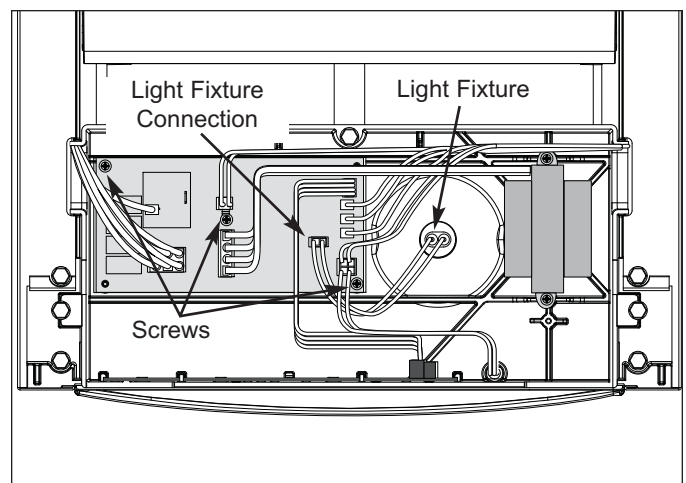

Figure 5-18. Control Box Components

Interior Components

Water Paddle Removal

The water paddles reduce the spraying water escaping the evaporator compartment. A steel rod which supports the water paddles sits in grooves molded into the evaporator cover.

NOTE: Also see *Water Shutter Assembly Removal under Components Below Top Cover.*

To remove the water paddles (See Figure 5-19):

1. Grasp both ends of water paddle assembly.
2. Lift one end of of water paddle assembly up while pivoting forward.
3. After first end is disengaged, pull other end forward to disengage rod from groove and pull assembly from bin area.

NOTE: *The individual water paddles will slide off steel rod unless held at both ends while removing.*

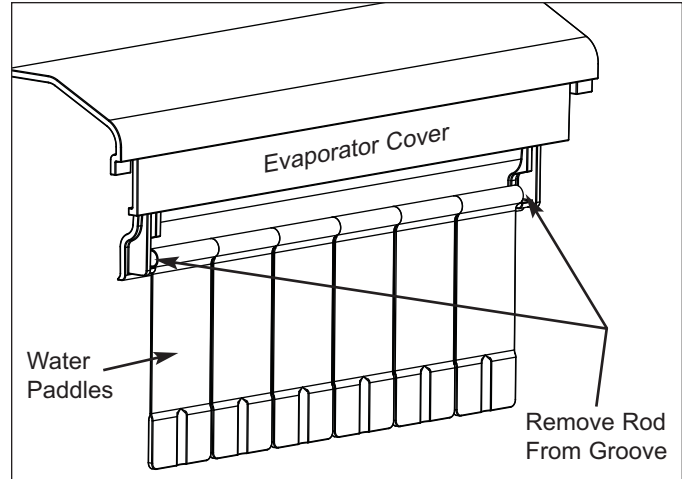

Figure 5-19. Water Paddle Removal

Ice Chute Removal

The ice chute is positioned over the spray nozzles and allows the ice to easily fall into the bin.

To remove the ice chute, grab protruding spray hole on one end, lift up and pull forward out of evaporator/spray bar enclosure (See Figure 5-20)

NOTE: *When reinstalling ice chute, it must be firmly positioned over the spray bar, with the front edge inside the water trough. Spray nozzles must align with the spray holes or spray water will fall into the bin.*

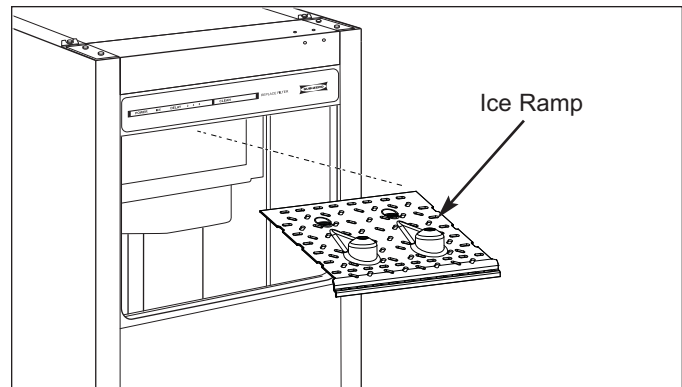

Figure 5-20. Ice Ramp Removal

Water Trough Drain Tube and Standpipe/Overflow Tube Removal

To remove the drain tube and overflow tube (See Figure 5-21):

1. At top of drain tube, disengage tube clamp teeth and remove clamp from tube and water trough nipple.
2. Pull drain tube up out of bin drain.
3. Pull drain tube and standpipe/overflow tube down out of water trough (water in the trough will drain into the bin).
4. Remove standpipe/overflow tube from drain tube by pulling.

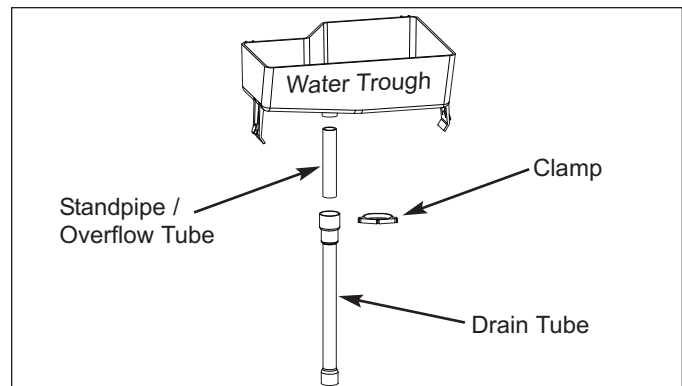

Figure 5-21. Drain Tube & Overflow Tube Removal

Water Trough Removal

To remove the water trough (See Figure 5-22):

1. Depress tabs on right and left side of the water trough.
2. Allow front of trough to drop as you pull forward to disengage the rear pins, then pull from bin.

Spray Bar Assembly Removal and Disassembly

To remove the spray bar assembly, the ice chute and water trough will need to be removed first, then (See Figure 5-23):

1. At water pump outlet, disengage tube clamp teeth and remove clamp from tube and pump outlet, then pull tube up off of pump outlet.
2. Lift spray bar assembly up and pull forward out of evaporator/spray bar enclosure.
3. With spray bar assembly removed, disengage clamp from tube at spray bar inlet, then pull tube from spray bar.
4. Unscrew water nozzles from spray bar.
5. Pull nozzle inserts out from spray bar outlets.

NOTES:

- *The spray bar also disassembles for easy cleaning.*
- *When reassembling, apply food grade lubricant to spray bar components when necessary.*

Water Pump Removal

To remove the water pump, first remove the ice chute, water trough and spray bar assembly, then (See Figure 5-24):

1. From inside ice bin, extract the mounting screw and eccentric washer securing water pump to upper bin liner.
2. Grasp pump and pull straight down until water pump disengages and electrical connector is visible, then disconnect electrical leads.
3. Extract grounding screw and wire from top of pump and pull pump from bin.

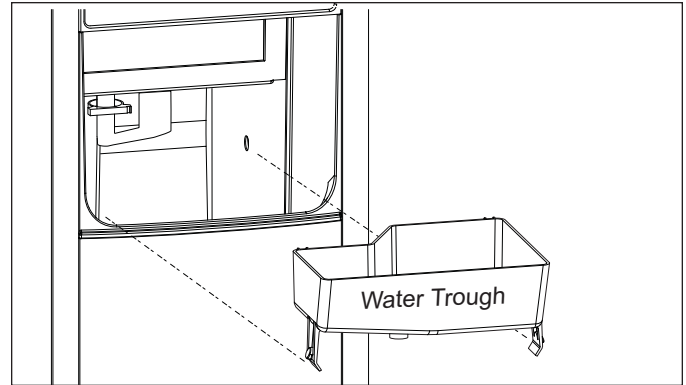

Figure 5-22. Water Trough Removal

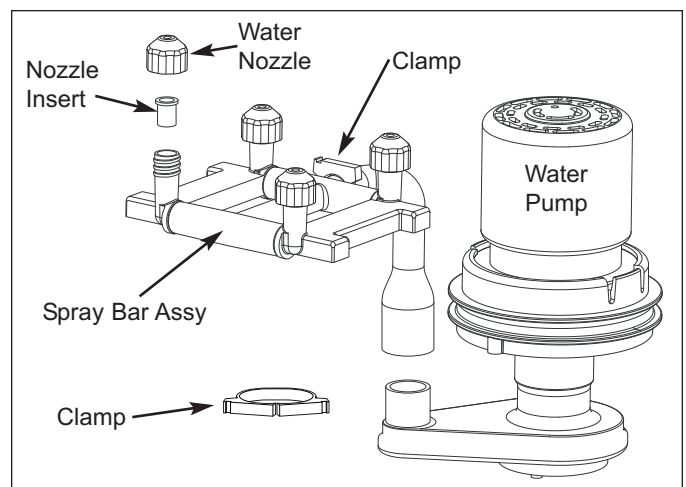

Figure 5-23. Spray Bar Removal & Disassembly

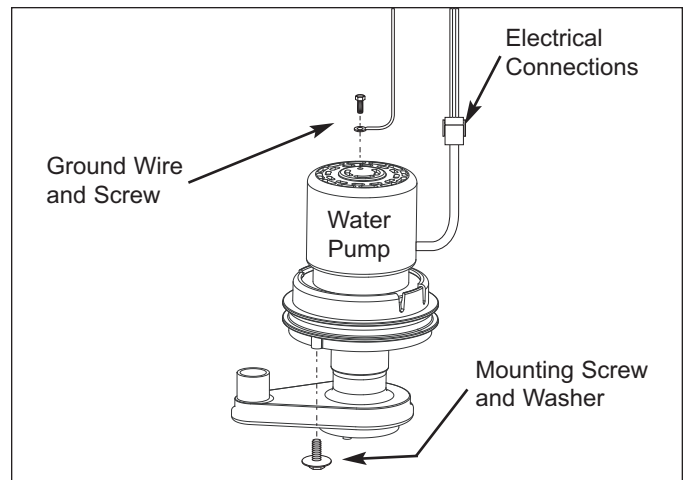

Figure 5-24. Water Pump Removal

Compressor/Condenser Area Components

Water Valve Removal

The water valve is located on the lower left front of the unit behind the kickplate, and is secured to the mounting bracket with a screw.

To remove the water valve, first remove the kickplate, then (See Figure 5-25):

1. Turn water supply off.
2. Disconnect water lines from front of valve by pushing collar around tube in while pulling tube away from valve.
3. Extract screw securing water valve to mounting bracket and pull valve forward.
4. Disconnect electrical connection from rear of valve.
5. Disconnect water lines from back of valve by pushing collar around tube in while pulling tube away from valve.

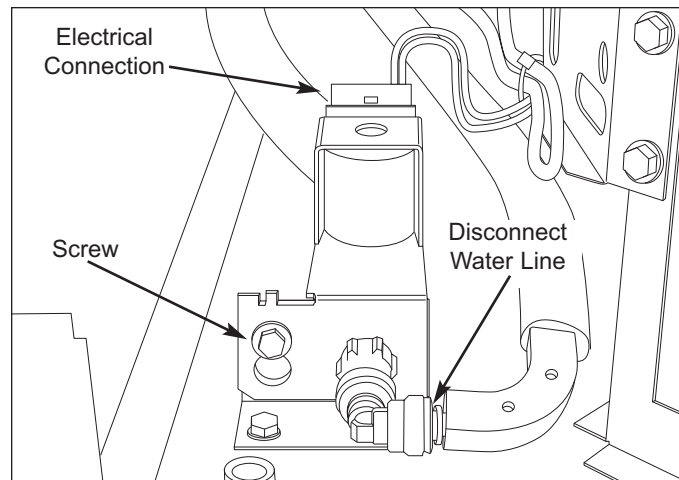

Figure 5-25. Water Valve Removal

Water Filter Enclosure and Head Removal

The water filter enclosure has flanges that engage four tabs on the bottom of the ice bin. Screws secure the water filter head to the bottom of the ice bin. The water inlet line connects to the right side of the head, and the water line exiting the head runs to the water valve.

To remove the water filter enclosure and head, first remove the kickplate, door, lower hinge assembly, trim plate, slide cover bracket and water filter panel. Then, (See Figure 5-26):

1. Turn water supply off.
2. Remove enclosure by pressing in on both sides just below rear tabs and pushing towards rear of unit until enclosure is free of tabs, then pull forward.
3. Disconnect water inlet line from right side of water filter head by pushing collar around tube toward head while pulling tube away from head.
4. Extract screws securing water filter head to bottom of ice bin.
5. Pull water filter head forward and disconnect outlet line from left side of head by pushing collar around tube toward head while pulling tube away from head.

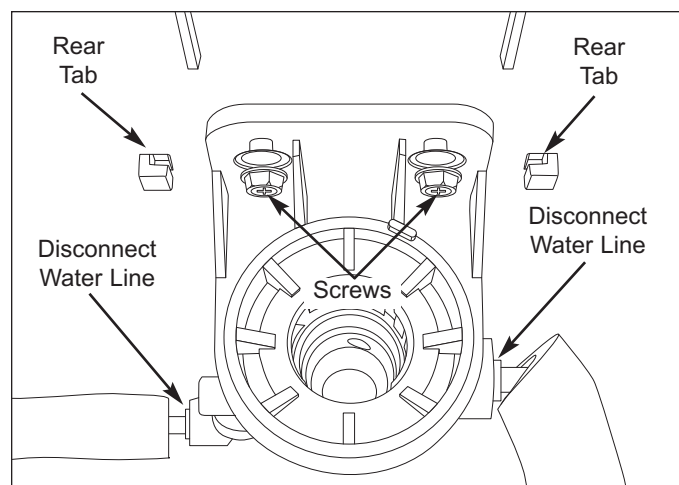

Figure 5-26. Water Valve Head Removal

Ice Bin Level (Thermostat) Switch Removal

The ice bin level switch is located on the lower right front of the unit behind the kickplate, secured to a bracket with a nut. The thermostat capillary tube runs from the rear of the switch to the back of the unit, then up to a hole in the foam and into the back of the bin thermostat sensing tube on the left side of the bin.

To remove the ice bin level switch, first remove the kickplate and upper back panel, then (See Figure 5-27):

1. Disconnect electrical leads from ice bin level switch.
NOTE: It is recommended to label the wire leads to assist in proper re-connection.
2. Extract nut that secures ice bin level switch to bracket.
3. At rear of unit, remove silicone sealant that seals capillary tube to foam.
4. Inside ice bin, remove silicone sealant at each end of thermostat sensing tube.
5. Push thermostat sensing tube toward rear of bin and out through hole in foam, then pull ice bin level switch from front of unit.

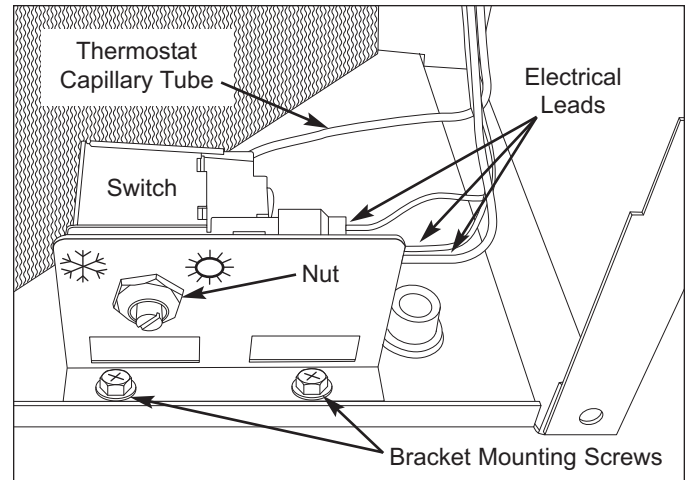

Figure 5-27. Ice Bin Level Switch Removal

Hot Gas Valve Solenoid Removal

The hot gas valve solenoid is attached to the top of the hot gas valve body with a screw.

To remove the hot gas valve solenoid, first remove the upper back panel and lower back utility panel from the rear of the unit, then (See Figure 5-28):

1. Disconnect solenoid electrical leads.
2. Extract solenoid mounting screw and lift solenoid from valve body.

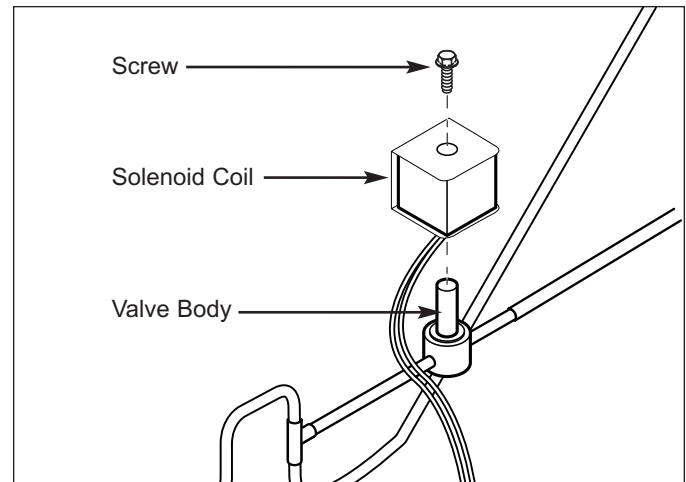

Figure 5-28. Hot Gas Valve Solenoid Removal

Drain Pump Assembly Removal (UC-15IP & UC-15IPO Only)

The drain pump assembly is located behind the condenser at the right rear corner of the compressor area, adhered to the tray with double-stick tape.

To remove the drain pump assembly, first remove the upper back panel and lower back utility panel from the rear of the unit, then (See Figure 5-29):

1. Disconnect inlet, discharge and vent tubes from top of drain pump.
2. Pry pump assembly up from tray, then pull it toward rear of unit until electrical leads are exposed.
3. Disconnect electrical leads and pull drain pump assembly from unit.

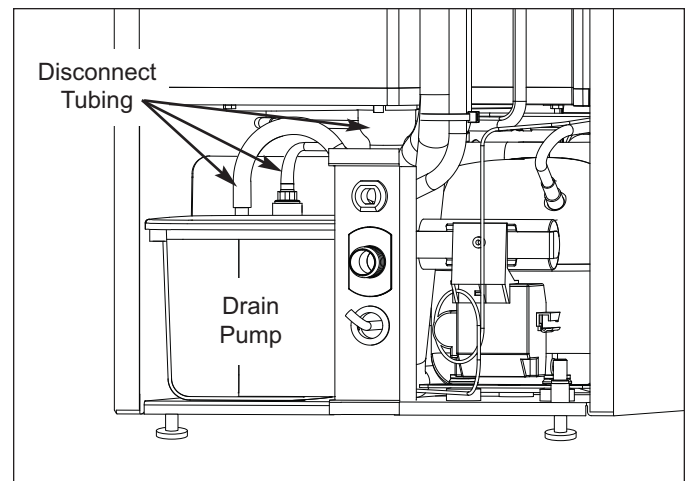

Figure 5-29. Drain Pump Removal

Liquid Line Thermistor Removal

The liquid line thermistor plugs directly into the control board, with its leads running to the right, then toward the rear of the unit under the top flange of the right side panel, down the back of the unit to the condenser discharge/liquid line where it is held to the tubing with a tube clamp. Foam insulation is then wrapped around the thermistor and tubing, secured with cable ties.

To remove the liquid line thermistor, first remove the top cover, control box cover, upper back panel and lower back utility panel (if a pump model, also remove the drain pump at this time), then (See Figure 5-30):

1. At top of unit, unplug thermistor from control board.
2. At condenser discharge tube, cut cable ties securing insulation over thermistor and remove insulation.
3. Loosen tube clamp and pull thermistor from clamp, then work it up toward top of unit, and out from under top flange of right side panel toward front of unit.

NOTE: When reinstalling thermistor, it must be attached to the condenser outlet with the tube clamp, and the insulation must be reapplied around the thermistor with cable ties.

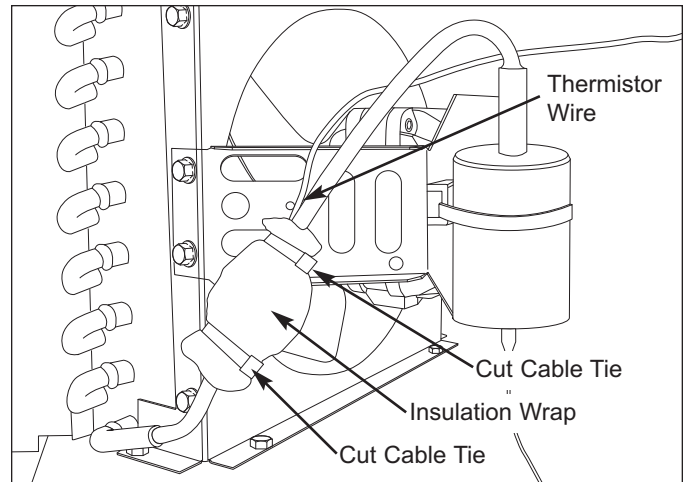

Figure 5-30. Liquid Line Thermistor Removal

Condenser Fan Motor Assembly Removal

The condenser fan motor is secured with screws that pass through the fan motor mounting bracket and into the condenser side brackets.

To remove the condenser fan motor assembly, first remove the kickplate, door, lower hinge assembly, trim plate, slide cover bracket, water filter panel, back panel and lower back utility panel (if a pump model, also remove the drain pump at this time), then (See Figure 5-31):

1. Disconnect fan motor electrical leads.
2. Extract screws securing condenser fan motor mounting bracket to each condenser side bracket.
3. Pull fan motor assembly from compressor area.
4. Extract screws securing fan motor to mounting bracket, then motor from mounting bracket.

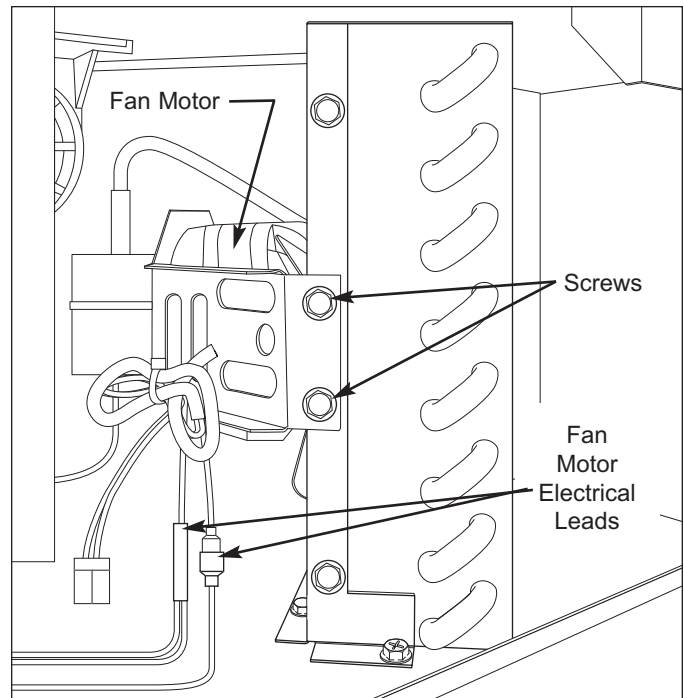

Figure 5-31. Condenser Fan Motor Removal

Sealed System Components

Hot Gas Valve Removal

The hot gas valve is attached to the compressor discharge line, after a T-connector. The outlet of the valve is the hot gas tube that runs up to the evaporator.

To remove the hot gas valve, first remove the kickplate, back panel and lower back utility panel, then after capturing the refrigerant from the sealed system (See Figure 5-32):

1. Disconnect solenoid electrical leads.
2. Using a tube cutter, cut valve inlet and outlet tubes approximately 1" from valve body.

NOTE: Do not sweat tubing apart. Doing so will induce moisture into the sealed system.

3. Lift valve assembly from compressor area.

NOTE: Always replace the filter-drier when opening the sealed system for service.

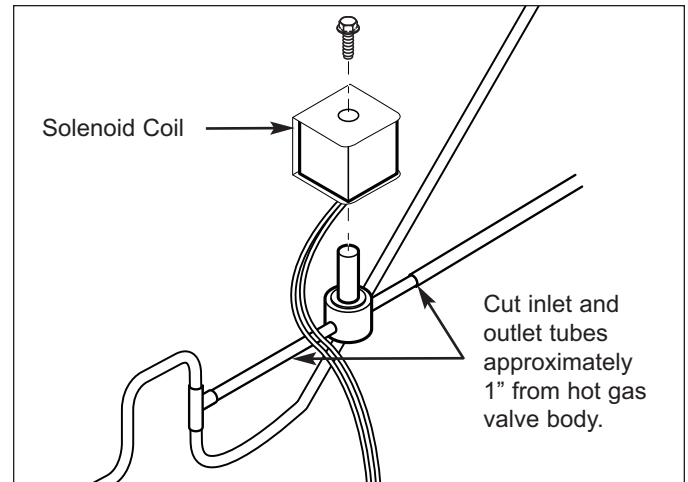

Figure 5-32. Hot Gas Valve Removal

High-Side Filter-Drier Removal

The high-side filter-drier is attached between the condenser outlet and the capillary tube, located behind the condenser assembly.

To access the high-side filter-drier, To remove the high-side filter-drier, first remove the kickplate, back panel and lower back utility panel, then after capturing the refrigerant from the sealed system (See Figure 5-33):

1. Using a tube cutter, cut drier inlet tube approximately 1" from drier.
2. Using a file, score a line around the capillary tube approximately one inch from filter-drier, then fatigue the capillary tube at this point until it separates.

NOTES:

- Do not sweat tubing apart. Doing so will induce moisture into the sealed system.
- After capillary tube separates, check tubing for internal burrs. If burrs exist, repeat step 2.

3. Lift filter-drier from compressor area.

NOTE: Always replace the filter-drier when opening the sealed system for service.

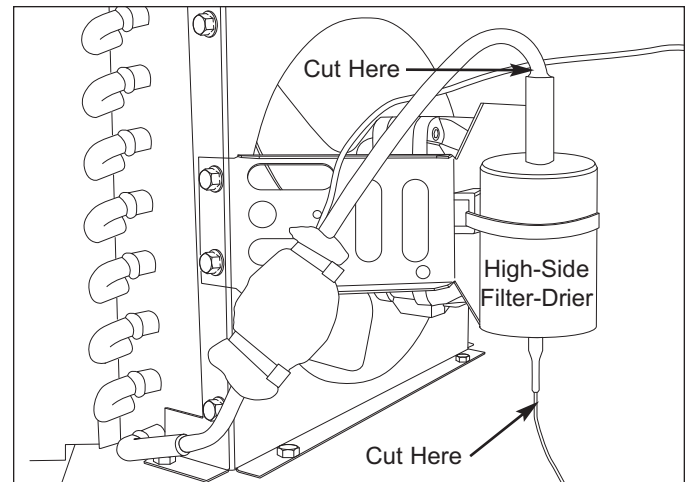

Figure 5-33. High-Side Filter-Drier Removal

Compressor Removal

The compressor sits on four grommets that are positioned over four tabs protruding up from the unit tray; cotter pins are then inserted through holes at the top of the tabs, above the compressor base and grommets.

To remove the compressor, first remove the kickplate, door, lower hinge assembly, trim plate, slide cover bracket, water filter panel, back panel and lower back utility panel, then after capturing the refrigerant from the sealed system (See Figure 5-34):

1. Remove electrical's cover and capacitor mounting assembly by inserting a flat-bladed screwdriver under capacitor and prying under tab while pulling cover toward rear of unit and down, then push cover down to release it from tabs on compressor.
2. Pull cover and capacitor away from compressor, then disconnect wire leads from compressor electrical's.
3. Using a tube cutter, cut suction and discharge tubes approximately 1" from compressor stubs.
NOTE: Do not sweat tubing apart. Doing so will induce moisture into the sealed system.
4. Extract cotter pins from above compressor grommets, then lift compressor up off of unit tray and pull toward rear of unit.

NOTE: Always replace the filter-drier when opening the sealed system for service.

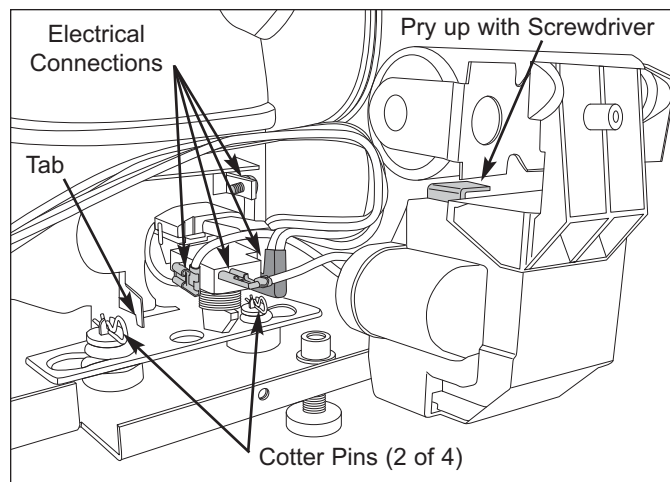

Figure 5-34. Compressor Removal

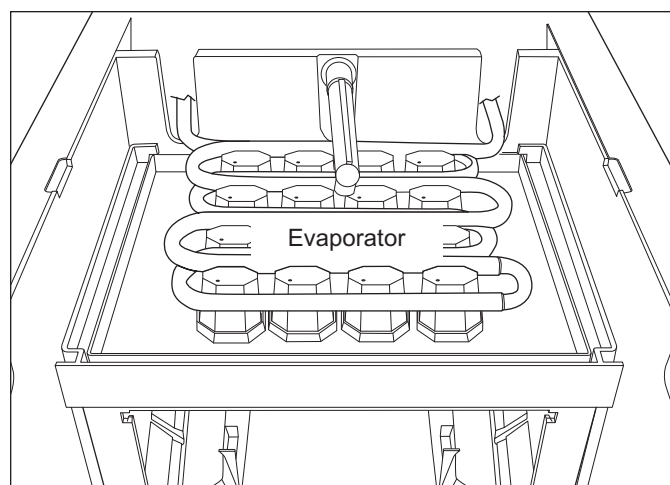

Figure 5-35. Evaporator Removal (Top/Front View)

Evaporator/Heat Exchanger Assembly Removal

The evaporator is located at the top of the machine under the top cover, atop the evaporator/spray bar enclosure, with the heat exchanger running down the back of the unit.

To remove the evaporator/heat exchanger assembly, first remove the kickplate, top cover, fill tube clamp, fill tube, back panel and lower back utility panel, then after capturing the refrigerant from the sealed system (See Figure 5-35):

1. Using a tube cutter, cut suction tube approximately 1" from compressor stub; cut hot gas tube approximately 1" from hot gas valve body; cut drier inlet tube approximately 1" from drier.

NOTE: Do not sweat tubing apart. Doing so will induce moisture into the sealed system.

2. Lift evaporator assembly from top of evaporator/spray bar enclosure.

NOTE: Always replace the filter-drier when opening the sealed system for service.

Condenser Removal

The condenser has a mounting bracket that is secured with screws to the condenser. The mounting bracket is then secured to the unit base tray with screws along the flange of the mounting bracket.

To remove the condenser, first remove the kickplate, door, lower hinge assembly, trim plate, slide cover bracket, water filter panel, back panel and lower back utility panel, then after capturing the refrigerant from the sealed system (See Figure 5-36):

1. Cut condenser inlet and outlet tubes approximately 1" from condenser stubs.

NOTE: Do not sweat tubing apart. Doing so will induce moisture into the sealed system.

2. Remove fan motor mounting bracket.
3. Extract screws securing flange of the condenser side brackets to the unit base tray.
4. Remove condenser from unit.

NOTE: Always replace the filter-drier when opening the sealed system for service.

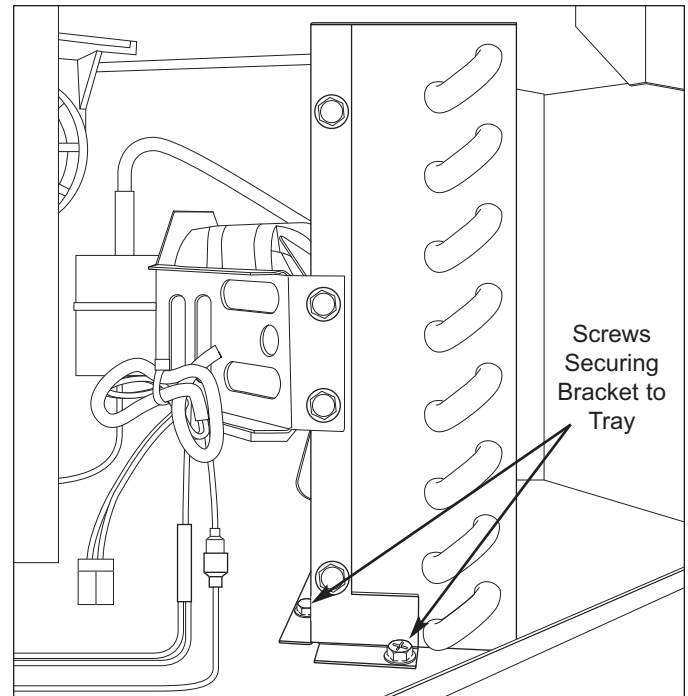

Figure 5-36. Condenser Removal (Front View)



SECTION 6

TROUBLESHOOTING GUIDE



TROUBLESHOOTING GUIDE

This section of the manual contains the Troubleshooting Guide which will help the Service Technician troubleshoot a model UC-15I.

How to Use the Troubleshooting Guide

The list below indicates how the Troubleshooting Guide is arranged. Identify the description of the problem that the unit is experiencing from the list and go to the page indicated. To the left of the problem description is a letter. Locate that letter in the left column of the Troubleshooting Guide. The center column will identify the possible causes for the problem. And, the information in the right column will explain what tests to perform in order to determine if what you are checking is the cause and/or what action to take to correct the problem.

Troubleshooting Guide Layout

	Page #
A. Ice Machine Does Not Operate	6-3
B. Ice Machine Operates, but Will Not Make Ice	6-3
C. Ice Machine Makes Ice, but Cubes Do Not Release from Mold	6-5
D. Slow/Low Ice Production	6-5
E. Cubes are Shallow, Incomplete or White	6-6
F. Cubes are Too Big	6-6
G. Bin Front Panel Sweats	6-6

NOTE: See WARNING below before beginning troubleshooting.

⚠ WARNING

ELECTRICAL SHOCK HAZARD! WHEN UNIT IS PLUGGED INTO AN ELECTRICAL OUTLET, HIGH (LINE) VOLTAGE IS APPLIED TO THE CONTROL BOARD (TERMINALS #20 AND #21) AT ALL TIMES. REMOVING THE CONTROL BOARD FUSE OR SWITCHING THE UNIT TO OFF WILL NOT REMOVE THE POWER SUPPLIED TO THE CONTROL BOARD.



PROBLEM	POSSIBLE CAUSE	TEST / ACTION
A. Ice Machine Does Not Operate	Improper Ambient Temperatures	Ambient air temperature minimum = 50°F (10°C), maximum = 100°F (38°C) for models UC-15I and UC-15IP; 110°F (43°C) for models UC-15IO and UC-15IPO. Advise customer. NOTE: Check control board light to see if ice machine shutdown on over temperature limit (control board light will flash rapidly).
	No Electrical Power to Appliance	a. Verify fuse or circuit breaker is closed. Replace fuse; switch circuit breaker on. If circuit breaker trips or fuse blows again, check for electrical short at outlet or appliance. b. Verify ice machine is plugged into functioning, properly polarized and grounded 3-prong receptacle. Plug unit in; repair electrical outlet or power cord. c. See Wiring Diagrams and check for voltage at appropriate points from outlet to control board in control box. Reconnect, repair, replace wiring or connectors.
	Control Board Fuse Open	Visually inspect fuse, replace if open.
	Transformer Fault	If interior light functions or red control board light is energized, transformer is OK. If transformer is receiving power but no output, replace transformer.
	Control Board Fault	If transformer is supplying power to control board and red control board light will not energize, replace control board.
	Control Panel (User Interface) Board Fault	If red control board light is energized, but pressing "POWER" does not energize green "POWER" light, then check wiring between main control board and control panel board. If wiring is defective, replace wire harness; if wiring is good, replace control panel board.
	Bin Thermostat Fault	With no ice on bin level sensing tube, thermostat should be closed; open with ice on tube after ~ 3 minutes. Replace if defective.
Drain Pump Safety Switch is Open. (UC-15IP, UC-15IPO Only)	Check drain hose for kinks or restrictions. Repair or replace bad hose.	
B. Ice Machine Operates, but Will Not Make Ice	Improper Ambient Temperatures	Ambient air temperature minimum = 50°F (10°C), maximum = 100°F (38°C) for models UC-15I and UC-15IP; 110°F (43°C) for models UC-15IO and UC-15IPO. Advise customer. NOTE: Check control board light to see if ice machine shutdown on over temperature limit (control board light will flash rapidly).
	Improper Water Pressure	Water pressure must be 20 - 80 psi (1.4 - 5.5 bar). Advise customer.

(Continued on next page)



PROBLEM	POSSIBLE CAUSE	TEST / ACTION
<p><i>(Continued from last page)</i> B. Ice Machine Operates, but Will Not Make Ice</p>	<p>No Water in Water Trough</p>	<ul style="list-style-type: none"> a. Water supply is off. Turn water supply on. b. Check water supply line for kinks or restrictions. Replace defective supply line. c. Check water filter. Replace if clogged. d. Check screens in water valve for obstructions. Clean screens or replace valve. e. Check for loose or disconnected wiring to water valve. Repair bad wiring. f. Check water valve integrity / operation. Replace if defective. g. Check trough for leak. Reposition/replace trough. h. Check standpipe. Reposition or replace.
	<p>No Water Spray from Spray Nozzles</p>	<ul style="list-style-type: none"> a. Check for blockage in spray nozzles. See Maintenance, Cleaning and Adjustment Information section of service manual. b. Check trough for leak. Reposition/replace. c. Check for loose or disconnected wiring to spray pump. Repair or reconnect wiring. d. Check operation of spray pump. Replace if defective.
	<p>No Airflow Through Condenser</p>	<ul style="list-style-type: none"> a. Check for obstructions in vents of kick-plate. Move/clear obstruction. b. Check condenser. Clean if dirty. c. Check for loose or broken condenser fan blade. Repair or replace blade. d. Check condenser fan motor wire connections. Repair or reconnect wiring. e. Check operation of condenser fan motor. Replace if defective.
	<p>Hot Gas Valve Stuck Open</p>	<p>Check operation of hot gas valve. Replace valve and drier if valve is defective.</p>
	<p>Liquid Line Thermistor Fault (Disconnected, Open or Misread)</p>	<ul style="list-style-type: none"> a. Check connection at board. Reconnect. b. Check for 30K - 33K ohms at ~32°F / 0°C or 8K - 12K ohms at ~77°F / 25°C. Replace if defective. <p>NOTE: A slow flashing light at control board indicates thermistor open or disconnected. A rapid flashing light indicates temperatures exceeded 170°F (77°C); look for cause and/or check thermistor resistance.</p>
	<p>Compressor Electrical Fault</p>	<ul style="list-style-type: none"> a. Check compressor electricals for loose or disconnected wiring. Repair or reconnect. b. Check operation of overload and relay. If defective, replace.
	<p>Sealed System Fault</p>	<ul style="list-style-type: none"> a. If power is at compressor and electricals are good, but compressor will not run, replace compressor and drier. b. Inspect sealed system for leaks, restrictions or inefficient compressor by observing frost patterns and feel tubing for irregular temperatures. Repair or replace components as needed.



PROBLEM	POSSIBLE CAUSE	TEST / ACTION
C. Ice Machine Makes Ice, but Cubes Do Not Release from Mold	Mineral Scale Build-up in Ice Making System	See Maintenance, Cleaning and Adjustment Information section of service manual.
	Freeze Time Too Long	See Cube Weight Check and Adjustment in Maintenance, Cleaning and Adjustment Information section of service manual.
	Hot Gas Valve or Solenoid Fault	<ul style="list-style-type: none"> a. Check for loose or disconnected wiring to hot gas valve solenoid. Repair bad wiring. b. Check integrity of solenoid coil. Replace if open or shorted. c. Check operation of hot gas valve. If stuck, replace valve and drier.
	Liquid Line Thermistor Fault (Disconnected, Open or Misread)	<ul style="list-style-type: none"> a. Check connection at board. Reconnect. b. Check for 30K - 33K ohms at ~32°F / 0°C or 8K - 12K ohms at ~77°F / 25°C. Replace if defective. <p>NOTE: A slow flashing light at control board indicates thermistor open or disconnected. A rapid flashing light indicates temperatures exceeded 170°F (77°C); look for cause and/or check thermistor resistance.</p>
	Control Board Fault	Check for power at control board to hot gas valve during harvest cycle. If no power is present, replace board.
D. Slow/Low Ice Production	Heavy/Frequent Ice Consumption	12 - 24 hours to fill bin is normal. Heavy/frequent ice consumption will slow refill process. Advise customer.
	Improper Ambient Temperatures	<p>Ambient air temperature minimum = 50°F (10°C), maximum = 100°F (38°C) for models UC-15I and UC-15IP; 110°F (43°C) for models UC-15IO and UC-15IPO. Advise customer.</p> <p>NOTE: Check control board light to see if ice machine shutdown on over temperature limit (control board light will flash rapidly).</p>
	Improper Water Temperatures	Water temperature minimum = 50°F (10°C), maximum = 80°F (27°C). Ice production slows with warmer water. Advise customer.
	Poor or No Airflow Through Condenser	<ul style="list-style-type: none"> a. Check for obstructions in vents of kick-plate. Move/clear obstruction. b. Check condenser. Clean if dirty. c. Check for loose or broken condenser fan blade. Repair or replace blade. d. Check condenser fan motor wire connections. Repair or reconnect wiring. e. Check operation of condenser fan motor. Replace if defective.
	Bin Drain Restricted, Melting Ice in Bin	Clean out bin drain and/or check installation for kinks in drain line.

(Continued on next page)



PROBLEM	POSSIBLE CAUSE	TEST / ACTION
<p><i>(Continued from last page)</i> D. Slow/Low Ice Production</p>	Water Filter Clogged	Check water filter. Replace if clogged.
	Water Escaping from Water Trough	a. Check water trough for leaks. Reposition trough or replace. b. Check standpipe position. Reposition standpipe.
	Water Inlet Valve Fault	a. Check screens in water valve for obstructions. Clean screens or replace valve. b. Check for loose wiring connections at water valve. Repair connections. c. Switch ice machine OFF. If water continues to enter machine, and water pressure is good, replace valve.
<p>E. Cubes are Shallow, Incomplete or White</p>	Dirty Ice Making System	a. Unit needs cleaning. See Maintenance, Cleaning and Adjustment Information section of service manual. b. Have water quality tested; qualified company could make appropriate filter recommendations. c. Have water softener inspected, repaired (if applicable).
	Not Enough Water in Water Trough	a. Check water supply line for kinks or restrictions. Replace defective supply line. b. Check water filter (partially clogged). Replace filter. c. Check screens in water valve for obstructions. Clean screens or replace valve. d. Check for loose wiring to water valve. Repair bad connections. e. Check trough for leak. Reposition/replace trough. f. Check standpipe. Reposition or replace.
	Freeze Time Too Short	See Cube Weight Check and Adjustment in Maintenance, Cleaning and Adjustment Information section of service manual.
<p>F. Cubes are Too Big</p>	Freeze Time Too Long	See Cube Size Control Adjustment instructions in Maintenance, Cleaning and Adjustment section of manual.
<p>G. Bin Front Panel Sweats</p>	High Relative Humidity with Front Panel Heater Fault	a. Check heater wire connections (in control box); reconnect or repair. b. Check resistance of heater; replace bin front panel assembly if heater is open or shorted.



SECTION 7

TECHNICAL DATA



Technical Data	
Minimum - Maximum Water Pressure	20 - 80 psi (1.4 - 5.5 bar)
Minimum - Maximum Water Temperature	35 - 90°F (1.6 - 32.2°C)
Liquid Line Thermistor Resistance (Ohms) at 32°F (0°C) / 77°F (25°C)	30K-33K / 8K-12K
Bin Thermostat Cut In / Cut Out	40°F(4.5°C) / 34°F(1.0°C)
Total Unit Amperage	4.1
Refrigerant Charge (134a)	5.6 oz. (1.5 kg)



SECTION 8

WIRING DIAGRAM



WARNING

-This wiring information is provided for use by qualified service personnel only.
 -Disconnect appliance from electrical supply before beginning service.
 -Be sure all grounding devices are connected when service is complete.
 -Failure to observe the above warnings may result in severe electrical shock.

WIRING DIAGRAM MODELS: UC-15I

115 VOLTS / 1 PHASE / 60 CYCLES

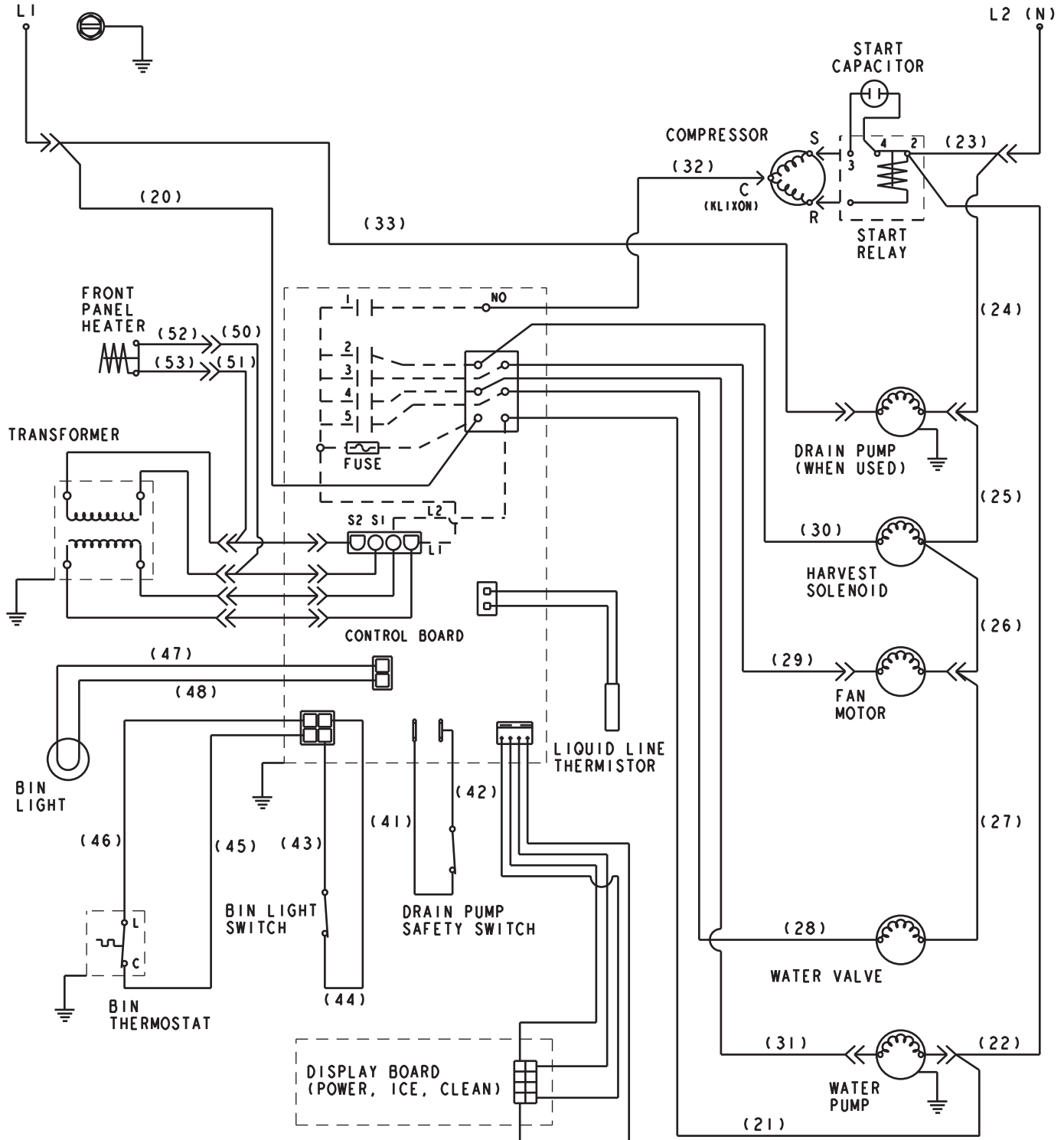

() - WIRE NUMBER DESIGNATION
 (# IS MARKED AT EACH END OF WIRE)

⇐⇐ - FEMALE/MALE CONNECTOR

04000758
 REV. 00

