

# SCOTSMAN'S ICE MACHINE SERVICE HANDBOOK

This booklet is intended as a quick reference for the service technician. It will not replace a service manual. Scotsman publishes a service manual for each model ice machine.

Not all of Scotsman's models are listed within this book. Because Scotsman has produced hundreds of different models of ice equipment (excluding voltages, finish, and cube sizes), it would be impractical to list them all.

All data listed in this book is subject to change without notice.

**Note:** Listed air cooled BTUs per hour are for air conditioning loads, not condenser sizing.

## Table Of Contents

AC25	Page 4	CME456	Page 33
AC30	Page 5	CME506	Page 34
AC55	Page 6	CME656	Page 35
AC125	Page 7	CME686	Page 36
AF1	Page 8	CME806	Page 37
AF300	Page 9	CME810	Page 38
AF325	Page 10	CME855	Page 39
AFE325	Page 11	CME865	Page 40
AFE400	Page 12	CME1000	Page 41
AF430	Page 13	CME1002	Page 42
AF730	Page 14	CME1056	Page 43
AN760	Page 15	CME1202	Page 44
CD200	Page 16	CME1356	Page 45
CD450	Page 17	CME1386	Page 46
CM250	Page 18	CME1402	Page 47
CM450	Page 19	CME1656	Page 48
CM500	Page 20	CME1686	Page 49
CM550	Page 21	CME1856	Page 50
CM650	Page 22	CME2006	Page 51
CM850	Page 23	CME2086	Page 52
CM855	Page 24	CMS1002	Page 53
CM1000	Page 25	CMS1202	Page 54
CM1200	Page 26	CMS1402	Page 55
CM1400	Page 27	CSW1	Page 56
CME250	Page 28	CSWE1	Page 57
CME500	Page 29	CSW45	Page 58
CME650	Page 30	CS55	Page 59
CME256	Page 31	CS60	Page 60
CME306	Page 32	CSE60	Page 61
		DC33	Page 62
		DCE33	Page 63

FD4	Page 64	NME650	Page 115
FD5	Page 65	NME654	Page 116
FD6	Page 66	NME950	Page 117
FD7	Page 67	NME954	Page 118
FDE470	Page 68	NME1250	Page 119
FM800	Page 69	NME1254	Page 120
FM1200	Page 70	NS650	Page 121
FM1202	Page 71	NSE650	Page 122
FME800	Page 72	NSE654	Page 123
FME804	Page 73	SCE170	Page 124
FME1200	Page 74	SCE275	Page 125
FME1204	Page 75	SLC300	Page 126
FME1500	Page 76	SLC400	Page 127
FME1504	Page 77	SLE300	Page 128
FME2404	Page 78	SLE400	Page 129
HC400	Page 79	TDE470	Page 130
HC700	Page 80	TDE550 or TDE650	Page 131
HC800	Page 81	SLIM LINE	Page 132
HC1200	Page 82	CUBER Op Sequence	Page 133
HD22 and HD30	Page 83	SCE170 Op Sequence	Page 137
HQD550	Page 84	Superheat	Page 138
HQD650	Page 85	Electrical Suffix Code	Page 139
HQD750	Page 86	Scotsman Model Id:	Page 140
MAR1400 and MAR2000	Page 87	Remote Systems	Page 141
MC30	Page 88	CM <sup>3</sup> Cuber Controller	Page 142
MC35	Page 89	Comp Diagnostics	Page 143
MC40	Page 90	Hot Gas Valves	Page 146
MCD200	Page 91	Kits	Page 147
MCM860	Page 92	Ice Storage Bin Doors	Page 148
MCM1062	Page 93	Inlet Water Valves	Page 149
MCM1462	Page 94	Cuber Capacity Check	Page 150
MDT2	Page 95	Refrigerant T-P Chart	Page 151
MDT3F and MDT4F	Page 96	CM <sup>3</sup> Thermistor Values	Page 152
MDT5N25 and MTD5N40	Page 97	CM <sup>3</sup> Thermistor Values	Page 153
MDT6N90	Page 98	Sonar	Page 154
MF6	Page 99	Potential Relays	Page 155
MF400	Page 100	Start Capacitors	Page 156
MF700	Page 101	Run Capacitors	Page 157
MF900	Page 102	CM <sup>3</sup> Purge Adjustment	Page 158
MFE400	Page 103	CM <sup>3</sup> - Blue Controller	Page 159
MH750	Page 104	CM <sup>3</sup> W L Sensor Diag	Page 160
ND550	Page 105	Warranty Summary	Page 162
ND650	Page 106	Date Code Chart	Page 163
ND750	Page 107	CM <sup>3</sup> Controller Revision (3 pages)	Page 164
NDE550 & NDE554	Page 108		
NDE650 & NDE654	Page 109		
NDE750 & NDE754	Page 110		
NM650	Page 111		
NM950	Page 112		
NM952	Page 113		
NM1250	Page 114		

## **AC25**

**Cuber with bin, 2 cube sizes, air or water cooled. In production from 1977 to 1997.**

Ice production	220 to 125 lb./24 hours
Air cooled water use, ice only*	43 gallons per 24 hours
Water use, water cooled condenser only*	369 gallons per 24 hours
BTUs per hour*	6300
Refrigerant type	R-12
Refrigerant charge	16.5 oz
Refrigerant pressures	Air cooled: 115 hi; 5 low, just before harvest
Average amps	12
Cubes per cycle	Small = 108    Medium = 56
Cycle time	17 to 25 minutes
Water solenoid valve flow rate	.25 g.p.m.

**\*90/70**

**During the harvest cycle, on air cooled models the fan and pump cycle with the discharge pressure. Water cooled discharge pressure is 135 PSIG.**

## **AC30**

**Cuber with bin, 2 cube sizes air and water cooled.  
In production from 1974 to 1997.**

Ice production	258 to 173 lb./24 hours
Air cooled water use, ice only*	84 gallons per 24 hours
Water use, water cooled condenser only*	418 gallons per 24 hours
BTUs per hour*	8100
Refrigerant type	R-12
Refrigerant charge	22 oz
Refrigerant pressures	Air cooled: discharge:125; 5 low, just before harvest
Average amps	14.2
Cube per cycle	Small = 198, Medium = 56
Water solenoid valve flow rate	.50 g.p.m.
Cycle time	17 to 25 minutes

**\*90/70**

**Water cooled discharge pressure is 135 PSIG.**

## **AC55**

**Cuber with bin, 1 cube size, air cooled only. In production between 1984 and 1988.**

Ice production	55 to 31 lb. per 24 hours
Water use*	19 gallons per 24 hours
BTUs per hour*	2500
Refrigerant type	R-12
Refrigerant charge	12 oz
Refrigerant pressures, freeze	125 hi; 2 low just before harvest
Average amps, freeze	4.6
Cubes per cycle	42
Water solenoid valve flow rate	.21 g.p.m.
Cycle time, 90/70	26 minutes

### **\*90/70**

**Similar to CS55; cube size control terminal number change: if a cube size control has a terminal # 6, then 1 became 6; 2 became 4; 4 became 2; 3 did not change.**

## **AC125**

**Cuber with bin, 1 cube size, air cooled only. In production from 1985 to 1994. Stainless steel cabinet in 1994.**

Ice production	118 to 82 lb. per 24 hours
Water use*	32 gallons per 24 hours
BTUs per hour*	4,600
Refrigerant type	R-12
Refrigerant charge	17 oz
Refrigerant pressures, freeze	125 hi; 5 low just before harvest
Average amps, freeze	8.3
Cube count	84
Water solenoid valve flow rate	.48 g.p.m.
Cycle time	18-28 ,minutes

**\*90/70**

**During harvest, when the pump is on, the fan is off.**

## **AF1**

**Flaker with bin, air cooled only. In production from 1974 to 1993, A through E models.**

Ice production	335 to 209 lb. per 24 hours
Water use*	41 gallons per 24 hours
BTUs per hour*	3700
Refrigerant type	R-12
Refrigerant charge	14 oz
Refrigerant pressures	150 - 125 hi; 12-13 low
Metering device	Cap tube
Average amps	7.8

**\*90/70**

**Minor changes between A and B models; compressor change between B and C models; wiring changes between C and D models; reservoir change between D and E models.**

## **AF300**

**New model in 1993. R-22 self contained undercounter flaker. Polyethylene cabinet. Air or water cooled. Replaced by AFE400 in 1995.**

Ice production	324 to 218 lb. per 24 hours
Air cooled water use*	33 gallons per 24 hours
Water cooled only: condenser water use*	438 gallons per 24 hours
BTUs per hour*	3700
Refrigerant Type	R-22
Refrigerant charge	Air cooled: 17 oz, Water cooled: 14 oz
Refrigerant pressures	220-260 hi; 24-25 low
Metering device	TXV
Average amps	9

**\*90/70**

**Reservoir change in 1994.**



## **AF325**

**Flaker with bin. Air cooled only. In production from 1978 to 1994. "B" model began 1988. Replaced by AFE325.**

Ice production	324 to 218 lb. per 24 hours
Water use*	41 gallons per 24 hours
BTUs per hour*	3700
Refrigerant Type	R-12
Refrigerant charge	14 oz
Refrigerant pressures	150 - 125 hi; 12-13 low
Metering device	Cap tube
Average amps	7.8

**\*90/70**

**No parts changes between A and B models.**

## **AFE325**

**R-134a self contained undercounter flaker.  
Production began October 1994**

Ice production	324 to 218 lb. per 24 hours
Water use*	33 gallons per 24 hours
BTUs per hour	3000
Refrigerant Type	R-134a
Refrigerant charge	11 oz
Refrigerant pressures	7 - 10 PSIG Suction; 130 - 165 PSIG Discharge
Metering device	Cap tube
Average amps	9

**\*90/70**

## **AFE400**

**New model in 1995. R-134a self contained undercounter flaker. Polyethylene cabinet. Air or water cooled.**

Ice production	400 to 250 lb. per 24 hours
Air cooled water use*	36 gallons per 24 hours
Water cooled only: condenser water use*	393 gallons per 24 hours
BTUs per hour*	3000
Refrigerant Type	R-134a
Refrigerant charge	Air cooled: 15 oz, Water cooled: 10 oz
Refrigerant pressures	125 - 160 hi; 12 - 13 low
Metering device	TXV, superheat 6 to 8°F.
Average amps	9

**\*90/70**

**B series: New water cooled condenser.**

## **AF430**

**Flaker with bin, air and water cooled. In production between 1978 and 1982.**

Ice production	441 to 325 lb. per 24 hours
Air cooled water use	50 gallons per 24 hours
Water use, water cooled condenser only	380 gallons per 24 hours
BTUs per hour	7300
Refrigerant Type	R-12
Refrigerant charge	18 oz for air cooled, 15 oz for water cooled.
Refrigerant pressures, (air cooled)	150 - 135 hi; 13 - 15 low
Average amps	10.8

**Note: The AF430 used the MF400 as an ice making chassis.**

## **AF730**

**Flaker with bin, air and water cooled. In production between 1978 and 1982.**

Ice production	792 to 460 lb. per 24 hours
Air cooled water use	98 gallons per 24 hours
Water use, water cooled condenser only	502 gallons per 24 hours
BTUs per hour	10,120
Refrigerant Type	R-12
Refrigerant charge	26 oz for air cooled, 23 oz for water cooled.
Refrigerant pressures	150 - 120 hi; 12 - 14 low
Average amps	14.8

**Note: The AF730 used the MF700 as an ice making chassis.**

## **AN760**

**Nugget ice maker with bin. Air and water cooled.  
Produced between 1983 and 1989.**

Ice production	636 to 415 lb. per 24 hours
Air cooled water use*	70 gallons per 24 hours
Water use, water cooled condenser only (90/70)	403 gallons per 24 hours
BTUs per hour*	7500
Refrigerant type	R-12
Refrigerant charge	26 oz for air cooled, 23 oz for water cooled.
Refrigerant pressures*	135 - 125 hi; 11-12 low
Average amps	16.4

**\*90/70**

**Ice making chassis similar to MH750.**

## CD200

**Motel Cube Dispenser. Production from 1988 to 1998. A, B and C models. Replaced by HD356.**

A model	No agitation timer
B model up to date code -04K	No agitation timer, but vend sequence changed so that user need not hold vend button in
B model after -04K	Agitation timer added. 12 or 24 hour of no vending would initiate a rotation of the vend rotor.
B model after 9/96	Timer changed to 2 hour
B model after 4/98*	Timer changed to 3 hour
B model after 6/98	Timer changed to 2 hour
C model	Timer changed to 6 hour

**\* Timer is part number 12-2431-01 plus a harness. Connect the timer's wire to the harness and the 3 hour wire to the 6 minute terminal.**

## **CD450**

**Cuber - Dispenser for motel/hotels. Air and water cooled. Produced between 1981 and 1989.**

Ice production	414 to 245 lb. per 24 hours
Air cooled water use*	77 gallons per 24 hours
Water use, water cooled condenser only*	480 gallons per 24 hours
BTUs per hour*	8500
Refrigerant Type	R-12
Refrigerant charge	27 oz
Refrigerant pressures*	125 hi; 5 low just before harvest
Average amps	14.9
Cube count	120
Water flow rate	2 flow controls @ .30 g.p.m. each
Cycle time	25 minutes

**\*90/70**



## **CM250**

**Modular cuber. Contour cubes, air or water cooled.  
In production 1985-94. Replaced by CME250.**

Ice production - Max	318 at 70A/50W (WC)
Ice production - Typical	230 lb at 90A/70W (AC)
Ice production - Min	187 at 100A/90W (AC)
Air cooled water use*	41 gallons per 24 hours
Water use, water cooled condenser only*	454 gallons per 24 hours
BTUs per hour*	6300
Refrigerant Type	R-502
Refrigerant charge	34 oz for air cooled, 30 oz for water cooled
Refrigerant pressures	350 to 200 hi; 22-30 low
Metering Device	Cap tube
Average amps	9 freeze, 11.8 harvest
Cube count per cycle	199
Batch Weight	2.5 - 3 lb
Water solenoid valve flow rate	.33 g.p.m.
Cycle time	14 to 18 minutes

**\* 90/70**

**CM250A-1 "E" model used different fan motor & bracket from prior models.**

## **CM450**

**Modular cuber. Contour cubes, air or water cooled. Single evaporator 230 volt. In production between 1983 and 1993.**

Ice production - Max	368 lb at 70A/50W (AC)
Ice production - Min	262 lb at 100A/90W (AC)
Air cooled water use*	37 gallons per 24 hours
Water use, water cooled condenser only*	610 gallons per 24 hours
BTUs per hour*	11500
Refrigerant Type	R-502
Refrigerant charge	28 oz for air cooled, 26 oz for water cooled
Refrigerant pressures	350 to 200 hi; 22-30 low
Metering device	Cap tube
Average amps	8.5 freeze, 12 harvest
Cube count	199
Batch Weight	2.5 - 3 lb
Water solenoid valve flow rate	.33 g.p.m.
Cycle time	13 to 15 minutes

\* 90/70

## CM500

**Modular Cuber. Contour cubes. Air, water or remote air cooled. In production 1985-94. Compressor change resulted in E model in 1992. Replaced by CME500.**

Ice production - max	505 lb at 70A/50W (WC)
ice production - typical	300 lb at 90A/70W (AC)
Ice production - min	242 lb at 100A/90W (AC)
Air cooled water use*	56 gallons per 24 hours
Water use, water cooled condenser only*	683 gallons per 24 hours
BTUs per hour*	9800
Refrigerant Type	R-502
Refrigerant charge	32 oz air cooled, 26 oz water cooled (E model water cooled is 28 oz), and 208 oz remote.
Refrigerant pressures	200 hi; 30 low end of freeze
Metering device	Two cap tubes
Average amps	14-17 (freeze) D model 9-10 (freeze) E model
Cubes per cycle	398 (5-6 lb)
Batch Weight	5 - 6 lb
Water solenoid valve flow rate	.75 g.p.m.
Cycle time	18 min @ 70/50
	25 min. @ 90/70

## **CM550**

**Modular Cuber, air cooled only. Similar to CM500 and CM650. Production ended 1992.**

Ice production - max	521 lb
Ice production - min	315 lb
Air cooled water use*	76 gallons per 24 hours
BTUs per hour*	10900
Refrigerant Type	R-502
Refrigerant charge	46 oz
Refrigerant pressures*	180 hi; 28 low just before harvest
Average amps*	15.5 (freeze) 17.5 (harvest)
Metering device	Two cap tubes
Cubes per cycle	398
Batch Weight	5 - 6 lb
Water solenoid valve flow rate	.75 g.p.m.
Cycle time*	17 minutes

\* 70/50

## **CM650**

**Modular Cuber. Contour cubes. Air, water or remote air cooled. In production 1984-94. Replaced by CME650.**

Ice production - Max	630 lb. at 70A/50W (AC)
Ice production - Typical	502 lb at 90A/70W (AC)
Ice production - Min	396 lb at 100A/90W (AC)
Air cooled water use*	87 gallons per 24 hours
Water use, water cooled condenser only*	1016 gallons/24 hours
BTUs per hour*	11700
Refrigerant Type	R-502
Refrigerant charge	47 oz for air cooled, 42 oz for water cooled, and 256 oz for remote.
Refrigerant pressures	End of freeze: 210 hi; 23 low. Harvest: 100 low.
Metering device	Two cap tubes
Average amps	7-9, single phase
Cube count	398
Batch Weight	3 - 6 lb
Water solenoid valve flow rate	.75 g.p.m.
Cycle time	14 to 19 minutes

**\*90/70**

## **CM850**

**Modular Cuber. Contour cubes. Air or water cooled.  
Produced between 1980 and 1983.**

Ice production	600 to 443 lb./24 hr.
Air cooled water use*	70 gallons per 24 hours
Water use, water cooled condenser only*	812 gallons per 24 hours
BTUs per hour*	12650
Refrigerant type	R-12
Refrigerant charge	58 oz
Refrigerant pressures	125 hi, 13 low, just before harvest
Metering device	3 cap tubes
Average amps	9
Cubes per cycle	861
Cycle time	19-23 minutes

**\* 90/70**

**Float in reservoir, do not confuse with CM855.**

## CM855

**Modular Cuber. Contour cubes. Air, water or remote air cooled. In production from 1987 thru early 1995.**

Ice production - max	800 at 70A/50W (AC)
Ice production - typical	623 at 90A/70W (AC)
Ice production - min	557 at 100A/90W (AC)
Air cooled water use*	124 gallons per 24 hours
Water use, water cooled condenser only*	1162 gallons per 24 hours
BTUs per hour*	12900
Refrigerant type	R-502
Refrigerant charge	Air cooled is 52, water cooled is 45 (A model) or 51 (B model). Remote is 256 oz
Refrigerant pressures*	240 hi; 28 low, just before harvest
Metering device	TXV, superheat 6 to 8°F.
Average amps	8
Cubes per cycle	597
Batch Weight	8 - 9 lb
Water solenoid valve flow rate	1 g.p.m.
Cycle time	15 - 23 minutes

\* 90/70

## CM1000

**Modular Cuber. Contour cubes. Air, water or remote air cooled. In production from 1986 thru early 1995. Air cooled only in 1991.**

Ice production - max	962 at 70A/50W (AC)
Ice production - typical	843 at 90A/70W (AC)
Ice production - min	657 at 100A/90W (AC)
Air cooled water use*	130 gallons per 24 hours
Water use, water cooled condenser only*	1390 gallons per 24 hours
BTUs per hour*	16330
Refrigerant type	R-502
Refrigerant charge	Air cooled is 64, water cooled is 45 (A model) or 51 (B model). Remote is 256 oz
Refrigerant pressures*	260 hi, 22 low just before harvest
Metering device	TXV, superheat 6 to 8°F.
Average amps	9 - 11
Cube count	597
Batch Weight	8 - 9 lb
Water solenoid valve flow rate	1 g.p.m.
Cycle time - 70/50	14 - 15 minutes
Cycle time - 90/70	16 - 17 minutes

\* 90/70



## CM1200

**Modular cuber. Contour cubes. Air or water cooled. Produced between 1980 and 1986. Many changes between A and C model.**

Ice production	941 - 708 lb./24 hr.
Air cooled water use*	160 gallons per 24 hours
Water use, water cooled condenser only	1239 gallons per 24 hours
BTUs per hour	21800
Refrigerant type	R-12
Refrigerant charge	A model = 108 oz C model = 100 oz
Refrigerant pressures*	135 hi, 14 low, just before harvest
Metering Device	5 cap tubes
Average amps	10
Cube count	A model = 1435 C model = 995
Water solenoid valve flow rate	C model, 1 g.p.m.
Cycle time	17 to 22 minutes

\* 90/70

## CM1400

**Modular Cuber. Contour cubes. Air, water or remote. In production 1985 -1991.**

Ice production	1392 at 70A/50W (AC)
Ice production - typical	1187 at 90A/70W (AC)
Ice production - min	1005 at 100A/90W (AC)
Air cooled water use*	163 gallons per 24 hours
Water use, water cooled condenser only*	1743 gallons per 24 hours
BTUs per hour*	24000
Refrigerant type	R-502
Refrigerant charge	Air cooled = 60 oz; water cooled = 52 oz, or 64 oz for units with a receiver; remote = 256 oz
Refrigerant pressures	265 hi, 25 low, just before harvest
Metering device	TXV, superheat 6 to 8°F.
Average amps	14-15
Cube count per cycle	995
Batch Weight	13.5 - 14.5 lb
Water solenoid valve flow rate	1 g.p.m.
Cycle time	14 - 18 minutes

\* 90/70

## **CME250**

**HP62 (R-404A) model. Production between 1994 and 1996. Air or water cooled. Replaced by CME256.**

Ice production - hi	302 at 70A/50W (AC)
Ice production - low	234 lb at 90A/70W (AC)
Air cooled water use*	47 gallons per 24 hours
Water use, water cooled condenser only*	431 gallons per 24 hours
BTUs per hour*	5100
Refrigerant type	R-404A
Refrigerant charge	27 oz for air cooled, 17 oz for water cooled
Refrigerant pressures (Water cooled freeze cycle set at 245 PSIG)	Freeze: 220 to 280 hi; 28-35 low. Harvest: 160-200 hi, 86-100 low.
Metering device	Internally equalized TXV, superheat 6 to 8°F.
Average amps	10-13 freeze, 11-14 harvest
Cube count per cycle	200
Batch Weight	2.5 - 3 lb
Water solenoid valve flow rate	.33 g.p.m.
Cycle time at 90/70	21 minutes
Cycle time at 70/50	16 minutes

\* 90/70

## **CME500**

**HP62 (R-404A) model. Production began in 1994. Air, water or remote. Uses non adjustable TXV. Harvest time at 2  $\frac{2}{3}$  minutes. Replaced by CME506 in 1996.**

Ice production - hi	459 lb at 70A/50W (AC)
Ice production - low	363 lb at 90A/70W (AC)
Air cooled water use*	90 gallons per 24 hours
Water use, water cooled condenser only*	642 gallons per 24 hours
BTUs per hour*	6275
Refrigerant type	R-404A
Refrigerant charge	32 oz for air cooled, 20 oz for water cooled
Refrigerant pressures (Water cooled freeze cycle set at 245 PSIG)	Freeze cycle: 275 to 290 hi; 35-40 low. Harvest cycle: 200 hi, 85-105 low. Minimum remote discharge pressure in freeze is 240 PSIG.
Metering device	TXV, superheat 6 to 8°F.
Average amps	10-12 freeze, 12-15 harvest
Cube count per cycle	400
Batch Weight	3 - 6 lb
Water solenoid flow rate	.75 g.p.m.
Cycle time	24 minutes @ 90/70
	19 minutes @ 70/50

\* 90/70

## CME650

HP62 (R-404A) model. Production began in 1994. Air water or remote. Uses non adjustable TXV. Harvest time at 2  $\frac{2}{3}$  minutes. Replaced by CME656.

Ice production - hi	626 lb at 70A/50W (AC)
Ice production - low	527 lb at 90A/70W (AC)
Air cooled water use*	93 gallons per 24 hours
Water use, water cooled condenser only*	811 gallons per 24 hours
BTUs per hour*	12500
Refrigerant type	R-404A
Refrigerant charge	Air cooled = 36 oz; water cooled = 27 oz; remote = 208 oz
Refrigerant pressures (Water cooled freeze cycle set at 245 PSIG)	Freeze: 300 to 350 hi; 25-30 low. Harvest: 160-200 hi, 80-90 low. Minimum remote discharge pressure in freeze is 240 PSIG.
Metering device	TXV, superheat 6 to 8°F.
Average amps	8 freeze, 9-11 harvest
Cube count per cycle	400
Batch Weight	3 - 6 lb
Water solenoid flow rate	.75 g.p.m.
Cycle time	19 minutes @ 90/70
	15 minutes @ 70/50

\* 90/70

## CME256

**New in 1996. Electronic Controls, R-404A refrigerant, plastic base. Single evaporator, primarily a 115 volt model.**

Ice production - hi	307 lb at 90A/70W (AC)
Ice production - low	240 lb at 70A/50W (AC)
Air cooled water use*	64.8 gallons / 24 hours
Water use, water cooled condenser only*	468 gallons per 24 hours
BTUs per hour	5500
Maximum Times (minutes)	50 freeze, 10 harvest
Refrigerant charge (R-404A)	24 oz for air cooled, 14 oz for water cooled
Suction pressure (PSIG)	25-27 - end of freeze
	95-105 - peak in harvest
Discharge pressure (PSIG)	240-250 - 5 min in freeze
	165-185 - minimum in harvest
Metering device	Internally equalized TXV, superheat 3 to 15°F.
Average comp. amps	7-9 freeze, 8 harvest
Batch Weight	3.25 - 3.5 lb
Cycle time	18 minutes @ 90/70 to 16 minutes @ 70/50

\* 90/70.

**Panel changes: C and E series. D series has PTCR. F series had wc condenser change.**

## CME306

**22" Wide Platform. Similar to CME256. Production began May 2000. Replaces SLE300.**

Ice production**	340 to 260 lb. /24 hours
Air cooled water use*	52 gallons per 24 hours
Water use, water cooled condenser only*	513
BTUs per hour	5500
Maximum Times (minutes)	45 freeze, 14 harvest
Refrigerant charge (R-404A)	23 oz for air cooled, 15 oz for water cooled
Suction pressure (PSIG)	25-27 - end of freeze
	95-105 - peak in harvest
Discharge pressure (PSIG)	203-266 - 5 min in freeze
	170-200 - minimum in harvest
Metering device	TXV, superheat 3 to 15°F.
Average amps	10 freeze, 11 harvest
Cube count per cycle	200
Batch Weight	3.25 - 3.5 lb
Water solenoid valve flow rate	1.25 g.p.m.
Cycle time	16 minutes @ 90/70 to 13 minutes @ 70/50

**\* 90/70 \*\* Air cooled, 70/50 & 90/70**

**B series: New water cooled condenser.**

**C series: New TXV**

# CME456

**22" Wide Platform. Similar to CME506. Uses two TXVs. C series has different TXVs from A & B.**

Ice production**	480 to 420 lb. /24 hours
Air cooled water use*	70 gallons per 24 hours
Water use, water cooled condenser only*	634 gallons per 24 hours
BTUs per hour	7000
Maximum Times (minutes)	45 freeze, 14 harvest
Suction pressure (PSIG)	32-36 - end of freeze
	88-100 - peak in harvest
Discharge pressure (PSIG)	236-293 - 5 min in freeze
	204-224 - minimum in harvest
Refrigerant charge (R-404A)	AC: 24 oz WC: 17 oz
Metering device TXV (2)	Superheat 3 to 15°F.
Average amps	13 freeze, 14 harvest
Batch Weight	6.5 - 7 lb
Water valve flow rate	1.25 g.p.m.
Water Cooled Cycle time	19 - 20 minutes

**\* 90/70 \*\* Air cooled, 70/50 & 90/70. B series: New water cooled condenser.**

### Air Cooled Cycle Time Detail

Water Temperature		Air Temperature				
		50	70	80	90	100
	40	18	19	20	22	23
	50	19	20	21	23	24
	70	20	21	22	24	26
	80	21	22	23	25	27
	90	22	23	24	26	28
	100	23	24	25	27	29



## CME506

**New in 1996. Electronic Controls, R-404A refrigerant, plastic base. Two evaporator, primarily a 115 volt model.**

Ice production	500 at 70/50 (AC)
Ice production	395 at 90A/70W (AC)
Air cooled water use*	94.3 gallons per 24 hours
Water use, water cooled condenser only*	714 gallons per 24 hours
BTUs per hour	7000
Maximum Times (minutes)	50 freeze, 14 harvest
Refrigerant charge (R-404A)	A-D series: AC 32 oz, WC 20 oz. E series AC 23 oz, WC 14 oz, F series AC 23 oz, WC 13 oz
Suction pressure (PSIG)	35-37 - end of freeze
	120-125 - peak in harvest
Discharge pressure (PSIG)	240-260 - 5 min in freeze
	165-175 - minimum in harvest
Metering device	TXV plus distributor, E series & higher have two TXVs. superheat 3 to 15°F.
Average comp. amps	10-11 freeze, 11-12 harvest
Batch Weight	6.5 - 7 lb
Cycle time	23 minutes @ 90/70
	19 minutes @ 70/50

\* 90/70

Panel changes: C and E series. E series also has 2 TXVs. D series has PTCR. F series had wc condenser change.

## CME656

**New in 1996. Electronic Controls, R-404A refrigerant, plastic base. Two evaporator, 230 volt model.**

Ice production**	705 to 585 lb./24 hours
Air cooled water use*	88 gallons per 24 hours
Water use, water cooled condenser only*	767 gallons per 24 hours
BTUs per hour	11,000
Maximum Times (minutes)	50 freeze, 14 harvest
Refrigerant charge	AC = 36; WC = 27; Remote = 232 w/ERC201; 280 w/ERC402
Air Cooled refrigerant pressures	Suction at the end of freeze: 26 PSIG; Suction peak in harvest: 84-88 PSIG  Discharge, 5 minutes into freeze: 215-290 (Water cooled freeze cycle set at 245 PSIG)
Metering device	TXV plus distributor, superheat 6 to 8°F.
Average comp. amps	7-8 freeze, 9-10 harvest
Batch Weight	6.5 - 7 lb
Cycle time	16 minutes @ 90/70 to 15 minutes @ 70/50

**\* 90/70 \*\* Air cooled, 70/50 & 90/70**

**Panel changes: C and E series. D series has PTCR. F series had wc condenser change.**

## **CME686**

**New in 2002. Remote low side cuber head. Part of 600 lb Eclipse System. use with CP686 and ERC680**

Ice production	620 to 560 lb / day
Water use	84 gallons per 24 hours (min if unit runs 24 hours)
BTUs per hour	8500
Max times	53 freeze, 13 harvest
Refrigerant charge	CP686, 232 oz. Charge listed on CP unit, not CME.
Refrigeration pressures	Suction at the end of freeze: 34 to 40 PSIG; Suction peak in harvest: 90 to 150 PSIG
	Discharge, at 70/70/50, 230 to 250 PSIG; at 120/110/100, 340 to 360 PSIG
Metering device	3 internally equalized TXVs , superheat 6 to 8°F.
Average comp. amps	Single phase: 5, three phase 3.5
Batch Weight	8 to 10 lb
Cycle time*	At 70/70/50, 19 to 23 minutes. At 90/90/70, 23 to 26 minutes. At 120/110/100, 26 to 38 minutes

## CME806

**New in 1998. Electronic Controls, R-404A refrigerant, plastic base. Two evaporator, 230 volt model. C model in 1999 (panel change).**

Ice production**	770 at 70/50 and 662 at 90/70
Air cooled water use*	92 gallons per 24 hours
Water use, water cooled condenser only*	1044 gallons per 24 hours
BTUs per hour	15,500
Max times	50 freeze, 14 harvest
Refrigerant charge	AC = 32; WC = 27=24; Remote = 232 w/ERC201; 280 w/ERC402
Air Cooled refrigerant pressures	Suction at the end of freeze: 26 PSIG; Suction peak in harvest: 84-88 PSIG
	Discharge, 5 minutes into freeze: 215-290 (Water cooled freeze cycle set at 245 PSIG)
Metering device	TXV plus distributor, superheat 6 to 8°F.
Average comp. amps	13
Batch Weight	6.5 - 7 lb
Cycle time*	13 - 15

**\* 90/70 \*\* Air cooled**

**Panel changes: C and E series. D series has PTCR. F series had wc condenser change.**

## CME810

**New in 2002. Remote low side cuber. Part of Eclipse system. Use with CP886 and ERC680 or CP1086 and ERC1086**

Ice production	800: 775 to 695, 1000: 880 to 850 lb / 24 hours
Water use (min)	800 lb: 104 gal., 1000 lb: 127 gal.
BTUs per hour	w/CP886 13,000. w/CP1086 19,000
Max times	40 freeze, 15 harvest
Refrigerant charge (R-404A)	w/CP886: 232 oz, w/CP1086: 272 oz. Charge listed on CP unit, not CME.
Refrigeration pressures	
70/70/50	Suction at end of freeze: w/CP886 26 - 32 PSIG. w/CP1086 24 to 30 PSIG Discharge: 220 to 240
90/90/70	Suction at end of freeze: w/CP886 30 - 36 PSIG. w/CP1086 26 to 32 PSIG Discharge: 230 to 260
120/110/100	Suction at end of freeze: w/CP886 36 - 42 PSIG. w/CP1086 32 to 36 PSIG Discharge: 350 to 375
Metering device	3 internally equalized TXVs, superheat 6 to 8°F.
Average comp. amps	Single phase, CP886 - 9, CP1086 -11 Three phase, CP886 - 6, CP1086 - 7
Batch Weight	8 to 10 lb
Cycle time, 800 lb model. 1000 lb model 1 - 2 min shorter	At 70/70/50, 17 to 19 minutes. At 90/90/70, 19 to 21 minutes. At 120/110/100, 20 to 23 minutes

## **CME855**

**42" wide R-404A Modular Cuber, air cooled only. Production began in 1995, replaced the CM855 air cooled replaced by CME806.**

Ice production*	611 lb/24 hr.
Remote air cooled water use*	123 gallons per 24 hours
BTUs per hour- Remote*	15500
Refrigerant type	R-404A
Refrigerant charge	36 oz
Refrigerant pressures	195 hi, 26 low, just before harvest
Metering device	TXV plus distributor, superheat 6 to 8°F.
Average amps	Compressor amps 9 - 11
Cube count per cycle	600
Water solenoid valve flow rate	.75 g.p.m.
Batch Weight	8 - 9 lb
Cycle time*	17 - 18 minutes

\* 90/70

## **CME865**

**30" wide modular cuber, water or remote air cooled. R-404A model. Production began in 1995 replaced by CME806.**

Ice production*	688 lb/24 hr.
Remote air cooled water use*	141 gallons per 24 hours
Water use, water cooled condenser only*	1162 gallons per 24 hours
BTUs per hour- Remote*	15500
Refrigerant type	R-404A
Refrigerant charge	WC = 36 oz; Remote = 336 oz
Refrigerant pressures (remote)	Suction = 28, Discharge = 210, just before harvest; Suction peak in harvest = 75- 100 PSIG. Water cooled discharge is a constant 245 PSIG
Metering device	TXV plus distributor, superheat 6 to 8°F.
Average amps	8.7 - 10.6
Water solenoid valve flow rate	.75 g.p.m.
Batch Weight	8 - 9 lb
Cycle time	14 - 17 minutes

\* 90/70

## **CME1000**

**42" wide modular cuber, air cooled only. R-404A model. Production began in 1995, replaced the CM1000, and was replaced by the CME1056A.**

Ice production*	826 lb./24 hr.
Air cooled water use*	170 gallons per 24 hours
BTUs per hour-Air Cooled*	18800
Refrigerant type	R-404A
Refrigerant charge	42 oz of R-404A
Refrigerant pressures	190 hi, 25 low, just before harvest
Metering device	TXV plus distributor, superheat 6 to 8°F.
Average amps	Compressor amps 10.7 - 13.3
Cube count per cycle	600
Water solenoid valve flow rate	.75 g.p.m.
Batch Weight	8 - 9 lb
Cycle time*	13 - 14 minutes

\* 90/70



## **CME1002**

**30" wide modular cuber, water or remote air cooled. R-404A unit. Production began in 1995. Replaced by the CME1056 in 1999.**

Ice production*	825 lb./24 hr.
Remote air cooled water use*	137 gallons per 24 hours
Water use, water cooled condenser only*	1180 gallons per 24 hours
BTUs per hour-Air Cooled*	18800
Refrigerant type	R-404A
Refrigerant charge	WC = 38 oz; Remote = 336 oz
Refrigerant pressures	350 - 210 hi, 24- 33 low, just before harvest. Water cooled discharge is a constant 245 PSIG.
Metering device	TXV plus distributor, superheat 6 to 8°F.
Average amps	9.9 - 13.6
Water solenoid valve flow rate	.75 g.p.m.
Batch Weight	8 - 9 lb
Cycle time	13 - 21 minutes

**\* 90/70**

**Hi pressure cut out changed to auto-reset in 1998**

## **CME1056**

**30" wide modular cuber, air, water or remote air cooled. R-404A unit. Production began in 1999. Replaced the CME1002.**

Ice production range	975 to 800 lb./24 hr.
Remote air cooled water use*	147 gallons per 24 hours
Water use, water cooled condenser only*	1365 gallons per 24 hours
BTUs per hour-Air Cooled	15.500
Max cycle times	31 freeze, 14 harvest
Refrigerant charge	AC = 44 oz, WC = 28 oz; Remote = 208 oz
Refrigerant pressures	255 - 275 hi, 25 - 30 low, just before harvest. Water cooled discharge is a constant 245 PSIG.
Metering device	TXV plus distributor, 5 to 15°F. Superheat
TXV bulb temp, end of freeze	-5°F to 0°F.
Average amps	10
Water solenoid valve flow rate	2.7 g.p.m.
Batch Weight	9 - 11 lb
Cycle time	14 to 16 minutes @70/50; 15 to 18 minutes @ 90/70

\* **90/70**

**F series: New water cooled condenser.**

## **CME1202**

**48" wide modular cuber, air cooled, water cooled or remote air cooled. R-404A unit. Production from 1995 to 1998. Replaced the CMS1202.**

Ice production*	1014 lb/24 hr.
Air cooled water use*	189 gallons per 24 hours
Water use, water cooled condenser only*	1501 gallons per 24 hours
BTUs per hour- Remote*	18800
Refrigerant type	R-404A
Refrigerant charge	AC = 64 oz, WC = 62 oz, Remote = 448 oz w/ERC401
Refrigerant pressures	210 - 315 hi, 30 - 35 low, just before harvest. Water cooled discharge is 245 PSIG.
Metering device	TXV plus distributor, superheat 8 to 10 <sup>o</sup> F.
Average amps	Single phase: 13 - 17; Three phase: 8 - 11
Water solenoid valve flow rate	1 g.p.m.
Batch Weight	13.5 - 14.5 lb
Cycle time	14- 19 minutes

**\* 90/70**

## **CME1356**

**48" wide modular cuber. Air cooled, water cooled or remote air cooled. R-404A unit. Production began in 1998.**

Ice production	1145 at 90/70 to 1400 lb. at 70/50
Air cooled water use*	223 gallons per 24 hours
Water use, water cooled condenser only*	1875 gallons per 24 hours of run time
BTUs per hour	21,500
Max cycle times	36 freeze, 14 harvest
Refrigerant charge	AC = 64, WC = 62, Remote = 288 oz w/ERC411
Refrigerant pressures	215 - 295 discharge, 27 - 33 suction, just before harvest. Water cooled discharge is 245 PSIG. Suction in harvest is 82 to 94 PSIG.
Metering device	TXV plus distributor, superheat 8 to 10°F.
Average amps: Freeze	Single phase: 15 - 17; Three phase: 9 - 10.
Average amps: Harvest	Single phase: 13; Three phase: 8 - 9
Batch Weight	16 lb
Cycle time	15 - 21 minutes

**\* 90/70 \*\* Preliminary Data**

**Changed to Single front panel in July of 1999.**

B Series (1999) has single front panel. C Series (2000) has plastic top panel. E series has louvered left side panel. F series: New water cooled condenser.

## CME1386

New in 2004. Remote low side cuber. Part of Eclipse system. Use with CP1316 and ERC1086

Ice production	1200 lb / 24 hours
Water use (min)	216 gal.
BTUs per hour	19,000
Max cycle times	50 freeze, 14 harvest
Refrigerant charge	288 ounces.
Refrigeration pressures	
70/70/50	Suction at end of freeze: 30 to 34 PSIG Discharge: 230 to 250
90/90/70	Suction at end of freeze: 32 to 36 PSIG Discharge: 250 to 270
120/110/100	Suction at end of freeze: 40 to 44 PSIG Discharge: 370 to 390
Metering device	1 externally equalized TXV, superheat 6 to 8°F.
Average comp. amps	Single phase, -15 Three phase, - 8
Batch Weight	16 lb
Cycle time	At 70/70/50, 12 to 13 minutes. At 90/90/70, 16 to 17 minutes. At 120/110/100, 26 to 28 minutes

## **CME1402**

**48" wide modular cuber. Air cooled, water cooled or remote air cooled. R-404A unit. Production from 1995 to 1998. Replaced the CMS1402.**

Ice production*	1240 lb./24 hr.
Air cooled water use*	231 gallons per 24 hours
Water use, water cooled condenser only*	1648 gallons per 24 hours
BTUs per hour	21100
Refrigerant type	R-404A
Refrigerant charge	AC = 64 oz, WC = 62 oz, Remote = 448 oz w/ERC401
Refrigerant pressures	210 - 315 discharge, 30 - 36 suction, just before harvest. Water cooled discharge is 245 PSIG. Suction in harvest is 77 to 100 PSIG.
Metering device	TXV plus distributor, superheat 8 to 10°F.
Average amps: Freeze	Single phase: 15 - 17; Three phase: 9 - 11.
Average amps: Harvest	Single phase: 15 - 22: Three phase: 9 - 14
Batch Weight	13.5 - 14.5 lb
Cycle time	13 - 18 minutes

\* 90/70

## **CME1656**

**Modular Cuber. Air Cooled, Water Cooled or Remote Air Cooled. Production began in 1998.**

Ice production	1650 at 70/50 to 1250 at 90/70
Air cooled water use*	225
Water use, water cooled condenser only*	2060
BTUs per hour	21,500
Max cycle times	50 freeze, 14 harvest
Refrigerant charge	AC = 64, WC = 62, Remote = 288 oz w/ERC411.
Refrigerant pressures	210 - 295 discharge, 21 - 36 suction, just before harvest. Water cooled discharge is 245 PSIG. Suction in harvest is 85 to 105 PSIG.
Metering device	TXV plus distributor, superheat 8 to 10°F.
Average amps: Freeze	Single phase: 15 - 17; Three phase: 11
Average amps: Harvest	Single phase: 15 -17; Three phase: 9
Batch Weight	19.2 lb
Cycle time	18 minutes at 70/50 & 22 minutes at 90/70

**\* 90/70**

**Changed to Single front panel in July of 1999.**

B Series (1999) has single front panel. C Series (2000) has plastic top panel. AC E series has louvered left side panel. F series: New water cooled condenser.

## **CME1686**

**New in 2004. Remote low side cuber. Part of Eclipse system. Use with CP1316 and ERC1086**

Ice production	1400 lb / 24 hours
Water use (min)	252 gal.
BTUs per hour	21,500
Max cycle times	50 freeze, 14 harvest
Refrigerant charge	288 ounces.
Refrigeration pressures	
70/70/50	Suction at end of freeze: 35 to 37 PSIG Discharge: 230 to 250
90/90/70	Suction at end of freeze: 35 to 37 PSIG Discharge: 250 to 270
120/110/100	Suction at end of freeze: 40 to 44 PSIG Discharge: 370 to 390
Metering device	1 externally equalized TXV, superheat 6 to 8°F.
Average comp. amps	Single phase, -15 Three phase, - 8
Batch Weight	19 - 20 lb
Cycle time	At 70/70/50, 15 to 16 minutes. At 90/90/70, 17 to 18 minutes. At 120/110/100, 28 to 29 minutes



## **CME1856**

**Production began in 2002. Water cooled only. Similar to CME1656W, but uses a Copeland Scroll compressor and larger condenser.**

Ice production	1825 to 1695 lb / 24 hours
Water use	273 gal/24 hours for ice, 2695 gal/24 hours for condenser
BTUs per hour	31,500 peak
Max cycle times	36 freeze, 14 harvest
Refrigerant charge	60 oz, R-404A
Refrigerant pressures	250 discharge, 23 suction, just before harvest. Suction in harvest is 80 PSIG.
Metering device	TXV plus distributor, superheat 8 to 10°F.
Average amps: Freeze	Single phase: 19; Three phase: 11
Average amps: Harvest	Single phase: 22; Three phase: 11
Batch Weight	20 lb
Cycle time	15 - 16 minutes

**\* 90/70**

**Softer compressor grommets used beginning -06S**

## **CME2006**

**Production began in 1998. Remote only. Similar to CME1656R, but uses a Copeland Scroll compressor.**

Ice production	1750 at 90/70 and 1930 at 70/50
Water use*	307 gallons per 24 hours
BTUs per hour	31,500
Max cycle times	36 freeze, 14 harvest
Refrigerant charge	Remote = 334 oz w/ERC611
Refrigerant pressures	225 - 270 discharge, 23 - 27 suction, just before harvest. Suction in harvest is 80 to 100 PSIG.
Metering device	TXV plus distributor, superheat 8 to 10°F.
Average amps: Freeze	Single phase: 19; Three phase: 11
Average amps: Harvest	Single phase: 22; Three phase: 11
Batch Weight	20 lb
Cycle time	15 - 16 minutes

**\* 90/70**

**B Series (1999) has single front panel. C Series (2000) has plastic top panel.**

**Softer compressor grommets used beginning -06S**

## CME2086

New in 2004. Remote low side cuber. Part of Eclipse system. Use with CP1316 and ERC1086

Ice production	1800 lb / 24 hours
Water use (min)	324 gal.
BTUs per hour	42,000
Max cycle times.	50 freeze, 14 harvest
Refrigerant charge	336 ounces.
Refrigeration pressures	
70/70/50	Suction at end of freeze: 25 to 29 PSIG Discharge: 230 to 250
90/90/70	Suction at end of freeze: 26 to 30 PSIG Discharge: 240 to 260
120/110/100	Suction at end of freeze: 30 to 34 PSIG Discharge: 340 to 360
Metering device	1 externally equalized TXV, superheat 6 to 8°F.
Average comp. amps	Single phase, 20 Three phase, 14
Batch Weight	19 - 20 lb
Cycle time	At 70/70/50, 11 to 12 minutes. At 90/90/70, 12 to 13 minutes. At 120/110/100, 17 to 18 minutes

## **CMS1002**

**Modular Cuber, Water or remote air cooled.  
Production began 5/91, ended 3/95.**

Ice production	932 to 646 lb/24 hr.
Remote air cooled water use*	120 gallons per 24 hours
Water use, water cooled condenser only*	1032 gallons per 24 hours
BTUs per hour-Remote*	16100
Refrigerant type	R-22
Refrigerant charge	Water cooled = 55 Remote = 256 oz.
Refrigerant pressures	240 hi, 20-22 low, just before harvest
Metering device	TXV plus distributor, superheat 6 to 8°F.
Average amps	13-14
Cube count per cycle	597
Water solenoid valve flow rate	.75 g.p.m.
Batch Weight	8 - 9 lb
Cycle time	15 - 19 minutes

\* 90/70

## **CMS1202**

**Modular Cuber, Air, water or remote air cooled.  
Production began 4/91, ended 3/95. B model with 2  
front panels in early 1992.**

Ice production	1280 to 825 lb./24 hr.
Air cooled water use*	152 gallons per 24 hours
Water use, water cooled condenser only*	1446 gallons per 24 hours
BTUs per hour-Air Cooled*	20100
Refrigerant type	R-22
Refrigerant charge	Air cooled = 60 oz; Water cooled = 64 Remote = 256 oz.
Refrigerant pressures	240 hi, 20-22 low, just before harvest
Metering device	TXV plus distributor, superheat 6 to 8°F.
Average amps	14-16
Cube count per cycle	995
Water solenoid valve flow rate	1 g.p.m.
Batch Weight	13.5 - 14.5 lb
Cycle time	16 - 20 minutes

\* 90/70

## **CMS1402**

**Modular Cuber, Air, water or remote air cooled.  
Production began 4/91, ended 3/95. B model with 2  
front panels in early 1992.**

Ice production	1450 to 1036 lb./24 hr.
Air cooled water use*	187 gallons per 24 hours
Water use, water cooled condenser only*	1648 gallons per 24 hours
BTUs per hour*	24000
Refrigerant type	R-22
Refrigerant charge	Air cooled = 60 oz; water cooled = 64 remote = 256 oz.
Refrigerant pressures	265 hi, 22 low, just before harvest
Metering device	TXV plus distributor, superheat 6 to 8°F.
Average amps	14-15
Cube count per cycle	995
Water solenoid valve flow rate	1 g.p.m.
Batch Weight	13.5 - 14.5 lb
Cycle time	14 - 18 minutes

\* 90/70

## **CSW1**

**Cuber with bin. Hot-wire grid unit. In production since 1983. C model (white) in 1992. Replaced by CSWE1 in 1995.**

Ice production	51 - 35 lb./24 hr.
Water use	n/a
BTUs per hour	1600
Refrigerant type	R-12
Refrigerant charge	7 oz
Refrigerant pressures end of the freeze cycle, at 90/70.	150 high, 7 low
Metering device	Cap tube
Power consumption	250 - 300 watts
Water solenoid valve flow rate	.25 g.p.m.
Cycle time	30-40 minutes

**Same unit as AC50.**

## **CSWE1**

**Cuber with bin. Hot-wire grid unit. R-134a. Production began 1995, ended 1999. Replaced by CSW45.**

Ice production	46 - 32 lb./24 hr.
Water use	45 gallons per 24 hours
BTUs per hour	1600
Refrigerant type	R-134a
Refrigerant charge	6.75 oz
Refrigerant pressures end of the freeze cycle, at 90/60.	85-100 high, 2-5 low
Metering device	Cap tube
Power consumption	250 - 300 watts
Water solenoid valve flow rate	.25 g.p.m.
Cycle time	18-22 at 70/60; 20-38 at 100/80; in minutes



## **CSW45**

**15" Wide Platform. Production began 1999. Thermistor and electronic circuit board control system. Replaced the CSWE1**

Ice production	40 - 36 lb./24 hr.
Water use	75 gallons per 24 hours
BTUs per hour	1600
Refrigerant type	R-134a
Refrigerant charge	6.5 oz
Refrigerant pressures end of the freeze cycle.	Low Side: 1-4 at 70/60; 2-6 at 100/80. High Side: 65-80 at 70/60; 85-105 at 100/80.
Metering device	Cap tube
Power consumption	250 - 300 watts
Water solenoid valve flow rate	.25 g.p.m.
Cycle time	18-22 minutes at 70/60 30-38 minutes at 100/80.

**If the evaporator thermistor is open or not connected to the control board the unit operates with a 20 minute freeze and a 3 minute harvest cycle.**

**B series in 2001 (compressor change)**

**C series in 2002 (evaporator & thermistor change)**

## CS55

Cuber with bin, one cube size. Air cooled. In production from 1989 thru 1994. Similar to AC55. Stainless steel cabinet in 1994. Discontinued in 1995.

Ice production	55 to 31 lb. per 24 hours
Water use	19 gallons per 24 hours
BTUs per hour	2100
Refrigerant type	R-12
Refrigerant charge	12 oz
Refrigerant pressures, freeze	125 hi; 2 low just before harvest
Metering device	Cap tube
Average amps, freeze	4.6
Cubes per cycle	42
Water solenoid valve flow rate	.21 g.p.m.
Cycle time, 90/70	26 minutes

## **CS60**

**New model in 1995. Replaced the CS55. Stainless steel, medium gourmet cube, R-22 refrigerant.**

Ice production	72 to 44 lb. per 24 hours
Water use	24 gallons per 24 hours
BTUs per hour	2400
Refrigerant type	R-22
Refrigerant charge	12 oz
Refrigerant pressures, freeze	End of freeze: 150 -160 PSIG Discharge; 10 - 11 PSIG Suction.
Refrigeration pressures, harvest	100 - 125 PSIG discharge, 90 PSIG max. suction
Metering device	Cap tube
Compressor amps, freeze	4 - 3.4
Cubes per cycle	24
Water solenoid valve flow rate	.21 g.p.m.
Batch weight	1 lb 1 oz
Cycle time, 90/70	23 minutes

## **CSE60**

**New model in 2002. Replaced the CS60. Stainless steel, medium gourmet cube, R-134a refrigerant.**

Ice production	72 to 44 lb. per 24 hours
Water use	24 gallons per 24 hours
BTUs per hour	2400
Refrigerant type	R-134a
Refrigerant charge	9.5 oz
Refrigerant pressures, freeze	End of freeze: 125 to 130 PSIG discharge 1 - 3 PSIG suction
Refrigeration pressures, harvest	83 - 125 PSIG discharge 120 PSIG max suction
Metering device	Cap tube
Compressor amps, freeze	4.3 to 3.6
Cubes per cycle	24
Batch weight	1 lb 1 oz
Water solenoid valve flow rate	.21 g.p.m.
Cycle time, 90/70	20 - 25 minutes

**New fan motor & blade in sn 615621 to 615640 and in s.n. 615844 to 615983.**

## **DC33**

**Cuber with bin, one cube size, air cooled only. Designed for home use. In production since 1980, replaced by DCE33 (R-134a) unit in 1995.**

Ice production	30 - 18 lb./24 hours
Water use	20 gallons per 24 hours
BTUs per hour	1400
Refrigerant type	R-12
Refrigerant charge	5 oz
Refrigerant pressures	5 low, just before harvest
Metering device	Cap tube
Average amps	4
Cubes per cycle	8
Water solenoid valve flow rate	.22 g.p.m.
Cycle time	25 minutes

**Similar to DC30**

**New drain pump in 1995.**

## **DCE33**

**Cuber with bin, one cube size, air cooled only. Designed for home use. In production since 1995.**

Ice production	30 - 18 lb./24 hours
Water use	20 gallons per 24 hours
BTUs per hour	1400
Refrigerant type	R-134a
Refrigerant charge	5 oz
Refrigerant pressures	5 low, just before harvest
Metering device	Cap tube
Average amps	4
Cubes per cycle	8
Water solenoid valve flow rate	.22 g.p.m.
Cycle time	25 minutes

## **FD4**

**Flaker - Dispenser. Air cooled only. Produced between 1972 and 1989.**

**FD470. Flaker - Dispenser. Air cooled only. Production began in 1989. B model with electric eyes in early 1992. Replaced by FDE470 in 1995.**

Ice production	470 to 274 lb./24 hours
Water use	49 gallons per 24 hours
BTUs per hour	7700
Refrigerant type	R-12
Refrigerant charge	18 oz
Refrigerant pressures*	150 hi, 15 low
Metering device	Cap tube
Average amps	12.8 (vending)

**\* 90/70**

**Minor changes between A and B models; portion control removed for C model; wiring changes between C and D model.**

**FD470 differs from the FD4 in the bin and rotor for the bin (and bin control with B model).**

## **FD5**

**Flaker - Dispenser. Air or water cooled. Produced between 1972 and 1985.**

Ice production	528 to 292 lb./24 hr.
Air cooled water use*	66 gallons per 24 hours
Water use, water cooled condenser only*	300 gallons per 24 hours
BTUs per hour*	5,800
Refrigerant type	R-12
Refrigerant charge	Air cooled, 24 oz Water cooled 20 oz.
Refrigerant pressures*	18
Metering device	Cap tube
Average amps*	10.4

**\* 90/70**

**Vend mechanism changed between A and B models; wiring changed between B and C models.**



## **FD6**

**Flaker - Dispenser. Air or water cooled. Produced between 1972 and 1981.**

Ice production	660 to 420 lb./24 hr.
Air cooled water use*	75 gallons per 24 hours
Water use, water cooled condenser only*	360 gallons per 24 hours
BTUs per hour*	6,900
Refrigerant type	R-12
Refrigerant charge	23 oz
Refrigerant pressures*	16
Metering device	Cap tube
Average amps	11.6

**\* 90/70**

**Vend mechanism changed between A and B models; wiring changed between B and C models.**

## **FD7**

**Flaker - Dispenser. Air or water cooled. Produced between 1972 and 1980.**

Ice production	720 - 420 lb./24 hr.
Air cooled water use*	80 gallons per 24 hours
Water use, water cooled condenser only*	330 gallons per 24 hours
BTUs per hour	8000
Refrigerant type	R-12
Refrigerant charge	23 oz
Refrigerant pressures*	Water cooled = 135 hi, 15 low, air cooled = 150 hi, 16 low
Metering device	Cap tube
Average amps	11.2

**\* 90/70**

**Compressor change between A and B models; wiring change between B and C models.**

## **FDE470**

**Flaker - Dispenser. Air cooled only. Production began in Oct. 1994. R-134a.**

Ice production	470 to 280 lb./24 hours
Water use	49 gallons per 24 hours
BTUs per hour	7700
Refrigerant type	R-134a
Refrigerant charge	14 oz
Refrigerant pressures*	135 - 175 hi, 13-14 low
Metering device	Cap tube
Average amps	12.8 (vending)

\* 90/70

## **FM800**

**Modular flaker. Air, water, or remote air cooled. All new design in 1989. Replaced by FME800 in 1994.**

Ice production	810 - 480
Air cooled water use*	77 gallons per 24 hours
Water use, water cooled condenser only*	920 gallons per 24 hours
BTUs per hour*	9500
Refrigerant type	R-502
Refrigerant charge	Air cooled = 34 oz; Water cooled = 28 oz; Remote air cooled = 256 oz.
Refrigerant pressures*	Air cooled: 315 hi, 34 low, Water cooled: 220 hi, 28 low.
Metering device	TXV, superheat 6 to 8°F.
Average amps*	16

\* 90/70

## FM1200

**Modular flaker. Air, water, or remote air cooled. All new design in 1989. Last production in late 1992.**

Ice production	1195 - 690 lb./24 hr.
Air cooled water use*	123 gallons per 24 hours
Water use, water cooled condenser only*	689 gallons per 24 hours
BTUs per hour*	10900
Refrigerant type	R-502
Refrigerant charge	Air cooled = 38 oz; Water cooled = 34 oz; Remote air cooled = 256 oz. All R502.
Refrigerant pressures*	Air cooled: 315 hi, 30 low, Water cooled: 220 hi, 28 low.
Metering device	TXV, superheat 6 to 8°F.
Average amps	7

**Note: FM2400 uses 2 FM1200 chassis in one cabinet.**

## FM1202

**Modular flaker. Air, water or remote air cooled. In production 1993 thru early 1994.**

Ice production, min.	787 lb./24 hr.
Ice production, max.	1206 lb./24 hr.
Air cooled water use*	113 gallons per 24 hours
Water use, water cooled condenser only*	679 gallons per 24 hours
BTUs per hour*	10900
Refrigerant type	R-22
Refrigerant charge	Air cooled = 32 oz; Water cooled = 28 oz; Remote air cooled = 256 oz.
Refrigerant Pressures - 70/50	Air cooled: 180 hi, 25 low, Water cooled: 220 hi, 25 low.
Refrigerant pressures - 90/70	Air cooled: 240 hi, 25 low, Water cooled: 220 hi, 25 low.
Metering device	TXV, superheat 6 to 8°F.
Compressor amps	4.8
Average amps	7

**Note: FM2402 uses 2 FM1202 chassis in one cabinet.**

## **FME800**

**HP62 (R-404A) model. Air, water or remote.  
Production 1994 to 2000.**

Ice production	760 - 480 lb./24 hr.
Air cooled water use*	83.4 gallons
Water use, water cooled condenser only*	535 gallons
BTUs per hour*	9500
Refrigerant type	R-404A
Refrigerant charge	Air cooled = 24 oz; Water cooled = 20 oz; Remote air cooled = 208 oz.
Refrigerant pressures*	Air cooled: 315 hi, 34 low, Water cooled: 245 hi, 34 low. Remote: 180 hi minimum, 30 low.
Metering device	TXV, superheat 6 to 8°F.
Average amps*	10

\* 90/70

## **FME804**

**AutoSentry model. Air, water or remote. Production began in March 2000.**

Ice production	760 - 480 lb./24 hr.
Air cooled water use*	83.4 gallons
Water use, water cooled condenser only*	535 gallons
BTUs per hour*	6200
Refrigerant type	R-404A
Refrigerant charge	Air cooled = 24 oz; Water cooled = 20 oz; Remote air cooled = 208 oz.
Refrigerant pressures*	Air cooled: 315 hi, 34 low, Water cooled: 245 hi, 34 low. Remote: 180 hi minimum, 30 low.
Metering device	TXV, superheat 6 to 8°F.
Average amps*	10

**\* 90/70**

**B series: New water cooled condenser.**



## **FME1200**

**HP62 (R-404A) model. Air, water or remote.  
Production from 1995 to 2000. 2 systems in  
FME2400.**

Ice production	Max. 1170 lb./hr. ; Min - 690 lb./24 hr.
Air cooled water use*	105 gallons
Water use, water cooled condenser only*	667 gallons
BTUs per hour*	10900
Refrigerant type	R-404A
Refrigerant charge	Air cooled = 30 oz; Water cooled = 24 oz; Remote air cooled = 208 oz.
Refrigerant pressures, air cooled and water cooled at 90/70	Air cooled: 275 hi, 35 low, Water cooled: 245 hi, 35 low.
Refrigerant pressures, remote	Remote: 205 hi minimum, 260 at 90/70, 30 - 35 low.
Metering device	TXV, superheat 6 - 8°F.
Average amps*	Compressor amps, 2.8 for 3 phase and 4.3 for single phase.

**\* 90/70**

**Note: FME1200RL production began 1997.**

## FME1204

**AutoSentry model. Air, water or remote. Production began in March 2000. 2 systems in FME2404.**

Ice production	Max. 1170 lb./hr. ; Min - 690 lb./24 hr.
Air cooled water use*	105 gallons
Water use, water cooled condenser only*	667 gallons
BTUs per hour*	7650
RL BTUH for cond unit sizing	6000 - 5750
Refrigerant type	R-404A
Refrigerant charge	Air cooled = 30 oz; Water cooled = 24 oz; Remote air cooled = 208 oz.
Refrigerant pressures, air cooled and water cooled at 90/70	Air cooled: 275 hi, 35 low, Water cooled: 245 hi, 35 low.
Refrigerant pressures, remote	Remote: 205 hi minimum, 260 at 90/70, 30 - 35 low.
Metering device	TXV, superheat 6 - 8°F.
Average amps*	Compressor amps, 2.8 for 3 phase and 4.3 for single phase.

\* 90/70

**B series: New water cooled condenser.**

## **FME1500**

**HP62 (R-404A) model. Air, water or remote.  
Production from July 1994 to March 2000.**

Ice production	1460 - 910 lb./24 hr.
Air cooled water use*	133 gallons
Water use, water cooled condenser only*	1126 gallons
BTUs per hour*	13200
Refrigerant type	R-404A
Refrigerant charge	Air cooled = 36 oz; Water cooled = 24 oz; Remote air cooled = 208 oz.
Refrigerant pressures*	Air cooled: 315 hi, 32 low, Water cooled: 245 hi, 32 low. Remote: 180 hi minimum, 28-38 low.
Metering device	TXV, superheat 6 to 8°F.

**\* 90/70**

**Note: FME1500RL production began 1997, uses 21" wide cabinet.**

## **FME1504**

**AutoSentry model. Air, water or remote. Production began in March 2000.**

Ice production	1460 - 910 lb./24 hr.
Air cooled water use*	133 gallons
Water use, water cooled condenser only*	1126 gallons
BTUs per hour*	10,000
RL BTUH for cond unit sizing	7250 - 7000
Refrigerant type	R-404A
Refrigerant charge	Air cooled = 36 oz; Water cooled = 24 oz; Remote air cooled = 208 oz.
Refrigerant pressures*	Air cooled: 315 hi, 32 low, Water cooled: 245 hi, 32 low. Remote: 180 hi minimum, 28-38 low.
Metering device	TXV, superheat 6 to 8°F.

\* 90/70

**B series: New water cooled condenser.**

## **FME2404**

**AutoSentry model. Air, water or remote. Production began in March 2000.**

Ice production	2455 to 1780 lb./24 hr.
Air cooled water use*	216 gallons
Water use, water cooled condenser only*	1333 gallons
BTUs per hour*	15,800
RL BTUH for cond unit sizing	12000 - 11800
Refrigerant type	R-404A
Refrigerant charge	Air cooled = 36 oz; Water cooled = 24 oz; Remote air cooled = 208 oz.
Refrigerant pressures*	Air cooled: 315 hi, 32 low, Water cooled: 245 hi, 32 low. Remote: 180 hi minimum, 28-38 low.
Metering device	TXV, superheat 6 to 8°F.

**\* 90/70**

**There are two refrigeration systems in the FME2404, similar to the NME1854.**

**B series: New water cooled condenser.**

## HC400

**Modular cuber. Air or water cooled. Produced between 1979 and 1987. Similar to MC30. 115 or 230 volt models.**

Ice production, medium cube; small cube 20% less	346 - 292 lb./24 hours
Air cooled water use*	70 gallons per 24 hours
Water use, water cooled condenser only	461 gallons per 24 hours
BTUs per hour*	9200
Refrigerant type	R-12
Refrigerant charge	Air cooled = 20 oz    Water cooled = 18 oz
Refrigerant pressures*	135 hi, 5 low, just before harvest
Metering device	Cap tube
Average amps	13 @ 115v
Cubes per cycle	Small = 198 Medium = 102
Water solenoid valve flow rate	.75 g.p.m.
Cycle time	19 minutes

\* 90/70

## HC700

**Modular cuber. Air or water cooled. Produced between 1979 and 1981. Similar to MC35. Two freezing chambers.**

Ice production medium cube (small cube makes 15-20% less)	600 - 440 lb. per 24 hr.
Air cooled water use*	100 gallons per 24 hours
Water use, water cooled condenser only*	730 gallons per 24 hours
BTUs per hour*	13200
Refrigerant type	R-12
Refrigerant charge	31 oz
Refrigerant pressures* (Air cooled, Water cooled = 135 hi)	155 hi, 6 low just before harvest
Metering device	2 cap tubes
Average amps*	9
Cubes per cycle	Small = 396 Medium = 204
Water solenoid valve flow rate	2 flow controls, .50 g.p.m. each
Cycle time	17 - 19 minutes

\* 90/70

## HC800

**Modular cuber. Air or water cooled. Produced between 1981 and 1987. Similar to MC40. Two freezing chambers.**

Ice production medium cube (small cube makes 15-20% less)	730 to 510 lb./24 hr.
Air cooled water use*	120 gallons per 24 hours
Water use, water cooled condenser only*	1,000 gallons per 24 hours
BTUs per hour*	13800
Refrigerant type	R-12
Refrigerant charge	Air cooled = 43 oz, Water cooled = 32 oz
Refrigerant pressures*	Air cooled: 165 high; 6 low just before harvest.
Metering device	2 cap tubes
Average amps*	10
Cubes per cycle	Small = 396 Medium = 204
Water solenoid valve flow rate	2 flow controls, .50 g.p.m. each
Cycle time	14 - 20 minutes

\* 90/70



## HC1200

**Modular cuber. Air or water cooled. Produced between 1977 and 1982. Two refrigeration systems.**

Ice production (small cube makes 15-20% less)	1300 to 970 lb./24 hr.
Air cooled water use*	200 gallons per 24 hours
Water use, water cooled condenser only*	2,000 gallons per 24 hours
BTUs per hour*	26500
Refrigerant type	R-12
Refrigerant charge	Each system: 39 oz air cooled; 31 oz, water cooled
Refrigerant pressures	150 hi, 10 low, just before harvest
Metering device	2 cap tubes per side
Average amps	25
Cubes per cycle (total of both systems)	Small = 792 Medium = 408
Water solenoid valve flow rate	2 flow controls each side, .50 g.p.m. each
Cycle time	16-20 minutes

\* 90/70

## **HD22 and HD30**

**New in 2004. Hotel ice dispensers. Replaced HD356 and HD156**

Agitation	3 seconds every 6 hours
Drive system	¼ HP gear drive
HD22 compatible with cubers:	CME306 or CME456
HD33 compatible with cubers	CME256 or CME506
Voltage	115

## **HQD550**

**Nugget ice maker - dispenser. Air or water cooled.  
Produced between 1986 and 1989.**

Ice production	522 to 304 lb. per 24 hours
Air cooled water use*	77 gallons per 24 hours
Water use, water cooled condenser only*	403 gallons per 24 hours
BTUs per hour*	7500
Refrigerant type	R-12
Refrigerant charge	Air cooled = 26 oz Water cooled = 23
Refrigerant pressures	150-135 hi; 18 low.
Metering device	Cap tube
Average amps*	15

\* 90/70

## **HQD650**

**Nugget ice maker - dispenser. Air or water cooled.  
Produced between 1981 and 1989.**

Ice production	600 to 390 lb. per 24 hours
Air cooled water use*	77 gallons per 24 hours
Water use, water cooled condenser only*	403 gallons per 24 hours
BTUs per hour*	7500
Refrigerant type	R-12
Refrigerant charge	Air cooled = 26 oz, Water cooled = 23
Refrigerant pressures*	150-135 hi; 10-12 low.
Metering device	Cap tube
Average amps*	15

\* 90/70

## **HQD750**

**Nugget ice maker - dispenser. Air or water cooled.  
Produced between 1981 and 1989.**

Ice production	636 to 415 lb. per 24 hours
Air cooled water use*	77 gallons per 24 hours
Water use, water cooled condenser only*	403 gallons per 24 hours
BTUs per hour*	7500
Refrigerant type	R-12
Refrigerant charge	Air cooled = 26 oz Water cooled = 23
Refrigerant pressures*	150-135 hi; 10-12 low.
Metering device	Cap tube
Average amps*	15

\* 90/70

## **MAR1400 and MAR2000**

**Industrial Flaker. Remote Low Side. Production began 2001.**

Ice production MAR1400	1260 to 1430
Ice production MAR2000	1700 to 1980
BTUs per hour* MAR1400	19,000
BTUs per hour* MAR2000	26,000
Refrigerant type	R-404A
Refrigerant pressures	23 PSIG (-11°F.)
Metering device	Automatic Expansion Valve

**\* For condensing unit**

## MC30

**Modular cuber, 2 cube sizes. Air or water cooled.  
Produced between 1975 and 1977. Similar to HC400.**

Ice production (small cube makes 15-20% less)	350 to 250 lb. per 24 hours.
Air cooled water use*	135 gallons per 24 hours
Water use, water cooled condenser only*	460 gallons per 24 hours
BTUs per hour*	9000
Refrigerant type	R-12
Refrigerant charge	Air cooled use 20 oz water cooled use 18 oz
Refrigerant pressures*	135 high, 6 low, just before harvest
Metering device	Cap tube
Average amps	13-15
Cubes per cycle	Small = 198 Medium = 102
Water solenoid valve flow rate	.75 g.p.m.
Cycle time	17 - 21 minutes

\* 90/70

## MC35

**Modular cuber, 2 cube sizes. Air or water cooled.  
Produced between 1974 and 1979. Similar to HC700.**

Ice production (small cube makes 15-20% less)	500 to 365 lb. per 24 hours
Air cooled water use*	90 gallons per 24 hours
Water use, water cooled condenser only*	730 gallons per 24 hours
BTUs per hour*	11800
Refrigerant type	R-12
Refrigerant charge	31 oz
Refrigerant pressures*	135 hi, 8 low just before harvest
Metering device	2 cap tubes
Average amps	9 (freeze)
Cubes per cycle	Small = 396 Medium = 204
Water solenoid valve flow rate	2 flow controls, .50 g.p.m. each
Cycle time	18 - 30 minutes

\* 90/70



## MC40

**Modular cuber, 2 cube sizes. Air or water cooled. Produced between 1975 and 1983. Similar to MC35, HC700, and HC800.**

Ice production	650 to 465 lb. per 24 hours
Air cooled water use*	80 gallons per 24 hours
Water use, water cooled condenser only*	1000 gallons per 24 hours
BTUs per hour*	12600
Refrigerant type	R-12
Refrigerant charge	Air cooled use 43 oz, Water cooled use 35 oz
Refrigerant pressures*	135 hi, 6 low just before harvest
Metering device	2 cap tubes
Average amps	10
Cubes per cycle	Small = 396 Medium = 204
Water solenoid valve flow rate	2 flow controls, .50 g.p.m. each
Cycle time	15 - 22 Minutes

\* 90/70

## **MCD200**

**Motel Cuber - Dispenser. Air or water cooled, 1 cube size. Produced between 1979 and 1986. Many changes A to C models**

Ice production	211 to 140 lb. per 24 hours
Air cooled water use*	40 gallons per 24 hours
Water use, water cooled condenser only*	390 gallons per 24 hours
BTUs per hour*	6300
Refrigerant type	R-12
Refrigerant charge	Air cooled is 26 oz; Water cooled is 25 oz.
Refrigerant pressures	115 hi; 5 low, just before harvest
Metering device	Cap tube
Average amps	12
Cubes per cycle	108
Water solenoid valve flow rate	.33 g.p.m.
Cycle time	17 - 25 minutes

\* 90/70

## **MCM860**

**Modular Cuber, Water or remote air cooled. 3 phase only. Production between 6/90 and early 1991.**

Ice production	735 to 572 lb./24 hr.
Air cooled water use*	133 gallons per 24 hours
Water use, water cooled condenser only*	N/A
BTUs per hour*	19,500
Refrigerant type	R-502
Refrigerant charge	Water cooled = 51 remote = 256 oz.
Refrigerant pressures	265 hi, 26 low, just before harvest
Metering device	TXV, superheat 6 to 8°F.
Average amps	5-6
Cube count per cycle	597
Water solenoid valve flow rate	.5 g.p.m.
Cycle time	16 - 24 minutes

\* 90/70

## **MCM1062**

**Modular Cuber, Water or remote air cooled. 3 phase only. Production began 6/91, ended 3/95.**

Ice production	932 to 646 lb./24 hr.
Air cooled water use*	120 gallons per 24 hours
Water use, water cooled condenser only*	1032 gallons per 24 hours
BTUs per hour*	21,900
Refrigerant type	R-22
Refrigerant charge	Water cooled = 55 remote = 256 oz.
Refrigerant pressures	265 hi, 22 low, just before harvest
Metering device	TXV, superheat 6 to 8°F.
Average amps	6-7
Cube count per cycle	597
Water solenoid valve flow rate	.75 g.p.m.
Cycle time	14 - 18 minutes

\* 90/70

## **MCM1462**

**Modular Cuber, Air, water or remote air cooled.  
Production began 1992, ended 3/95.**

Ice production	1450 to 1036 lb./24 hr.
Air cooled water use*	187 gallons per 24 hours
Water use, water cooled condenser only*	1648 gallons per 24 hours
BTUs per hour*	24000
Refrigerant type	R-22
Refrigerant charge	Air cooled = 60 oz; water cooled = 64 remote = 256 oz.
Refrigerant pressures	265 hi, 22 low, just before harvest
Metering device	TXV plus distributor, superheat 6 to 8°F.
Average amps	14-15
Cube count per cycle	995
Water solenoid valve flow rate	1 g.p.m.
Batch Weight	13.5 - 14.5 lb
Cycle time	14 - 18 minutes

\* 90/70

## **MDT2**

**Ice Maker Dispenser. Production began June 2002.  
Ice form is cubelet**

Ice production	273 to 198 lb./24 hours
Water use*	48 gallons per 24 hours
Refrigerant type	R-134a
Refrigerant charge	13 oz
Refrigerant pressures*	135 - 175 hi, 13-14 low
Metering device	Cap tube
Average amps	6

\* 90/70

## **MDT3F and MDT4F**

**Ice Maker Dispenser. Production began June 2001.  
Replaces TDE470.**

Ice production, MDT4	470 to 280 lb./24 hours
Ice production, MDT3	392 to 294 lb./24 hours
Water use, MDT4	49 gallons per 24 hours
BTUs per hour, MDT4	4000
Refrigerant type	R-134a
Refrigerant charge, MDT3	12 oz
Refrigerant charge, MDT4	14 oz
Refrigerant pressures*	135 - 175 hi, 13-14 low
Metering device	Cap tube
Average amps	12.8 (vending)

**\* 90/70**

**New bin bottom and ice chute May 2002.**

## **MDT5N25 and MTD5N40**

**Ice Maker Dispenser. Production began June 2001.  
Replacing TDE550 and TDE650.**

Ice production	605 - 380 lb.
Water use, ice only*	56 gallons
Water use, water cooled condenser only*	558 gallons
BTUs per hour*	5000
Refrigerant type	R-404A
Refrigerant charge	Air cooled = 24 ounce Water cooled = 18 oz
Refrigerant pressures	250 - 220 high; 38 low. Water cooled discharge pressure should be 245 PSIG.
Metering device	TXV
Average amps	10 - 13

**\*90/70**

**B series: New water cooled condenser.**



## **MDT6N90**

**Ice Maker Dispenser. Production began June 2001.  
Replacing NDE750.**

Ice production	720 - 435
Water use, ice only*	65
Water use, water cooled condenser only*	599
BTUs per hour*	7000
Refrigerant type	R-404A
Refrigerant charge	Air cooled = 32 ounce Water cooled = 22 oz
Refrigerant pressures	250 - 220 high; 38 low Water cooled discharge pressure at 245 PSIG.
Metering device	TXV, superheat 6 to 8°F.
Average amps	12 - 13

**\*90/70**

**B series: New water cooled condenser.**

## MF6

**Modular flaker. Air or water cooled. Produced between 1975 and 1989. Many changes between A and C models. The chart below is for A and B models, for C model, double the MF900.**

Ice production	2400 - 1690 lb./24 hr.
Air cooled water use*	250 gallons per 24 hours
Water use, water cooled condenser only*	1640 gallons per 24 hours
BTUs per hour	23,000
Refrigerant type	R-12
Refrigerant charge	Air cooled = 57 oz Water cooled = 41 oz
Refrigerant pressures* (Air cooled, water cooled hi side = 135)	150 - 160 hi, 12-15 low
Metering device	A and B models have 1 cap tube, C models have 2 cap tubes
Average amps (Air cooled)	13 (single phase) 9 (three phase)

\* 90/70

**“A” model has 7" diameter evaporator.**

**“B” model has 7" diameter evaporator, and internally protected auger drive motor.**

**“C” model has two 3" diameter evaporators.**

## **MF400**

**Modular flaker. Air or water cooled. In production since 1978. Changes between A and B models. "A" model similar to MF3C.**

Ice production	443 to 327 lb./24 hr.
Air cooled water use*	21 gallons per 24 hours
Water use, water cooled condenser only*	320 gallons per 24 hours
BTUs per hour*	6100
Refrigerant type	R-12
Refrigerant charge (Changed in 1982)	Air cooled = 18 oz, Water cooled = 15 oz.
Refrigerant pressures* Using 23 oz. air and 20 oz. water charge of R-12	Air cooled: 190 high, 16 low Water cooled: 135 high, 14 low
Metering device	Cap tube
Average amps	10

**\* 90/70**

**"B" model change is to evaporator, spout and plastic ice chute.**

**Ice chute changed to stainless steel 5/91.**

## **MF700**

**Modular flaker. Air or water cooled. Produced between 1978 and 1989. Similar to MF4C and AF730.**

Ice production	792 - 460 lb./24 hr.
Air cooled water use*	98 gallons per 24 hours
Water use, water cooled condenser only*	502 gallons per 24 hours
BTUs per hour*	10100
Refrigerant type	R-12
Refrigerant charge	26 oz for air cooled, 23 oz for water cooled.
Refrigerant pressures	150 - 120 hi; 12 - 14 low
Metering device	Cap tube
Average amps	14.8

**\*90/70**

**Major Changes: Spout from brass to Stainless Steel.**

**Drive motor from split phase to P.S.C.**

## **MF900**

**Modular flaker. Air, water or remote air cooled.  
Produced between 1978 and 1989. Similar to MF5C.**

Ice production	1151 to 725 lb./24 hr.
Air cooled water use*	120 gallons per 24 hours
Water use, water cooled condenser only*	750 gallons per 24 hours
BTUs per hour*	13800
Refrigerant type	R-12
Refrigerant charge	Air cooled use 31 oz Water cooled use 28 oz
Refrigerant pressures	135 high, 13 low
Metering device	Cap tube
Average amps	8

**\*90/70**

**Major Changes: Spout from brass to Stainless Steel.**

**Drive motor from 1/4 H.P. split phase to 1/3 H.P. P.S.C.**

## **MFE400**

**Modular Flaker. Replaces the MF400. Production began October 1994.**

Ice production	480 to 310 lb./24 hr.
Air cooled water use*	46 gallons per 24 hours
Water use, water cooled condenser only*	287 gallons per 24 hours
BTUs per hour	4000
Refrigerant type	R-134a
Refrigerant charge	15 oz
Refrigerant pressures	Air cooled: 137 - 170 high, 13-14 low Water cooled: 135-140 high
Metering device	Cap tube
Average amps	10

\* 90/70

**B series: New water cooled condenser.**

## MH750

**Modular nugget ice maker. Air, water or remote air cooled. Produced between 1981 and 1989. Many changes between A and C model.**

Ice production	636 to 415 lb. per 24 hours
Air cooled water use*	77 gallons per 24 hours
Water use, water cooled condenser only	403 gallons per 24 hours
BTUs per hour	7500
Refrigerant type	R-12
Refrigerant charge	Air cooled = 26 oz Water cooled = 23 Remote = 224
Refrigerant pressures	150-135 hi; 10-12 low.
Metering device	Air and Water use cap tube, Remote used AXV.
Average amps	15

**\*90/70**

**Changes: Breaker bearing, gearbox, added a relay to control box, evaporator.**

## **ND550**

**Nugget ice maker - Dispenser. Air or water cooled. Production began in 1989. B model with water station in 1992.**

Ice production	535 - 335 lb./24 hr.
Air cooled water use*	70 gallons per 24 hours
Water use, water cooled condenser only	800 gallons per 24 hours
BTUs per hour	8600
Refrigerant type	R-502
Refrigerant charge	Air cooled = 24 ounce Water cooled = 18 oz
Refrigerant pressures	250-230 hi; 30 low
Metering device	TXV, superheat 6 to 8°F.
Average amps	16

**\*90/70**

**Agitator, portion control and bin drive motor changes.**



## **ND650**

**Nugget ice maker - dispenser. Air or water cooled.  
Production began in 1989.**

Ice production	620 - 380 lb./24 hr.
Water use, ice only*	75 gallons per 24 hours
Water use, water cooled condenser only*	972 gallons per 24 hours
BTUs per hour*	9200
Refrigerant type	
Refrigerant charge	Air cooled = 24 ounce Water cooled = 18 oz, all R502.
Refrigerant pressures	250 - 220 high; 30 low
Metering device	TXV, superheat 6 to 8°F.
Average amps	16

**\*90/70**

**Agitator, portion control and bin drive motor changes.**

## **ND750**

**Nugget ice maker - Dispenser. Air or water cooled.  
Production began in 1989.**

Ice production	700 to 425 lb./24 hr.
Water use, ice only*	82 gallons per 24 hours
Water use, water cooled condenser only*	928 gallons per 24 hours
BTUs per hour*	9700
Refrigerant type	R-502
Refrigerant charge	Air cooled = 26 ounce Water cooled = 28 oz
Refrigerant pressures	250 - 220 high; 30 low
Metering device	TXV, superheat 6 to 8°F.
Average amps	16.5

**\*90/70**

## **NDE550 & NDE554**

**HP62 (R-404A) model. Air or water cooled.  
Production began in July 1994.**

Ice production	535 - 335
Water use, ice only*	49
Water use, water cooled condenser only*	441
BTUs per hour*	8600
Refrigerant type	R-404A
Refrigerant charge	Air cooled = 24 ounce Water cooled = 18 oz
Refrigerant pressures	250 - 220 high; 40 low Water cooled discharge pressure at 245 PSIG.
Metering device	TXV, superheat 6 to 8°F.
Average amps	10 - 13

**\*90/70**

## **NDE650 & NDE654**

**HP62 (R-404A) model. Air or water cooled.  
Production began in July 1994.**

Ice production	605 - 380 lb.
Water use, ice only*	56 gallons
Water use, water cooled condenser only*	558 gallons
BTUs per hour*	9200
Refrigerant type	R-404A
Refrigerant charge	Air cooled = 24 ounce Water cooled = 18 oz
Refrigerant pressures	250 - 220 high; 38 low. Water cooled discharge pressure should be 245 PSIG.
Metering device	TXV, superheat 6 to 8°F.
Average amps	10 - 13

**\*90/70**

## **NDE750 & NDE754**

**HP62 (R-404A) model. Air or water cooled.  
Production between July 1994 and March 2000;  
NDE754 similar, its production was between March  
2000 and June 2001.**

Ice production	720 - 435
Water use, ice only*	65
Water use, water cooled condenser only*	599
BTUs per hour*	9700
Refrigerant type	R-404A
Refrigerant charge	Air cooled = 32 ounce Water cooled = 22 oz
Refrigerant pressures	250 - 220 high; 38 low Water cooled discharge pressure at 245 PSIG.
Metering device	TXV, superheat 6 to 8°F.
Average amps	12 - 13

**\*90/70**

## NM650

**Modular nugget ice maker. Air, water or remote air cooled. Production began in 1989.**

Ice production	745 - 430 lb./24 hours
Air cooled water use*	72 gallons per 24 hr.
Water use, water cooled condenser only*	712 gallons per 24 hr.
BTUs per hour	9500
Refrigerant type	R-502
Refrigerant charge	Air cooled = 34 oz Water cooled = 28 oz Remote air cooled = 256 oz.
Refrigerant pressures* Air Cooled.	310 hi, 30 low
Refrigerant pressures* Water Cooled	220 hi, 28 low
Metering device	TXV, superheat 6 to 8°F.
Average amps (air cooled)	15.5

**\* 90/70**

**Changes: Black gearmotor and split phase auger drive.**

## NM950

**Modular nugget ice maker. Air, water or remote air cooled. Production between 1989 and 1992.**

Ice production	1100 - 625 lb./24 hr.
Air cooled water use*	126 gallons per 24 hr.
Water use, water cooled condenser only	700 gallons per 24 hr.
BTUs per hour	11300
Refrigerant type	R-502
Refrigerant charge	Air cooled = 38 oz; Water cooled = 34 oz; Remote air cooled = 256 oz.
Refrigerant pressures	Air cooled: 315 hi, 30 low, Water cooled: 220 hi, 28 low.
Metering device	TXV, superheat 6 to 8°F.
Average amps	7.2

\* 90/70

**Note: NM1850 has 2 NM950 ice making chassis in its cabinet.**

**Changes: Black gearmotor and split phase auger drive.**

## NM952

**Modular nugget ice maker. Air, water or remote air cooled. Production began in 1993, ended in 1995.**

Ice production	1113 - 712 lb./24 hr.
Air cooled water use*	101 gallons per 24 hr.
Water use, water cooled condenser only	679 gallons per 24 hr.
BTUs per hour	11300
Refrigerant type	R-22
Refrigerant charge	Air cooled = 32 oz; Water cooled = 28 oz; Remote air cooled = 256 oz.
Refrigerant pressures, 70/50	Air cooled: 180 hi, 25 low, Water cooled: 220 hi, 25 low.
Refrigerant pressures 90/70	Air cooled: 240 hi, 25 low, Water cooled: 220 hi, 25 low.
Metering device	TXV, superheat 6 to 8°F.
Average amps	7.2

\* 90/70

**NM1852 models use 2 NM952 ice making units in one cabinet.**



## **NM1250**

**Modular nugget ice maker. Air, water or remote air cooled. Production began in 1989 and ended in 1994.**

Ice production	1345 - 765 lb./24 hr.
Air cooled water use*	140 gallons per 24 hours
Water use, water cooled condenser only*	935 gallons per 24 hours
BTUs per hour*	13200
Refrigerant type	R-502
Refrigerant charge	Air cooled = 40 oz; Water cooled = 30 oz; Remote air cooled = 208 oz.
Refrigerant pressures	250-210 high, 30 low
Metering device	TXV, superheat 6 to 8°F.
Average amps	9.5

**\*90/70**

**Changes: Black gearmotor and split phase drive motor.**

## **NME650**

**HP62 (R-404A) model. Air, water or remote.  
Production from 1994 to 2000.**

Ice production	745 - 430 lb/24 hr.
Air cooled water use*	62 gallons
Water use, water cooled condenser only	535 gallons
BTUs per hour	9500
Refrigerant type	R-404A
Refrigerant charge	Air cooled = 24 oz; Water cooled = 20 oz; Remote air cooled = 208 oz.
Refrigerant pressures	Air cooled: 315 hi, 34 low, Water cooled: 245 hi, 34 low.
Metering device	TXV - 6 - 8°F. superheat
Compressor amps	8 -9
Gearmotor amps	3.1 - 3.5

**\* 90/70**

## **NME654**

**AutoSentry model. Air, water or remote. Production began March 2000.**

Ice production	745 - 430 lb/24 hr.
Air cooled water use*	62 gallons
Water use, water cooled condenser only	535 gallons
BTUs per hour	7000
RL BTUH for cond unit sizing	4400 - 4200
Refrigerant type	R-404A
Refrigerant charge	Air cooled = 24 oz; Water cooled = 20 oz; Remote air cooled = 208 oz.
Refrigerant pressures	Air cooled: 315 hi, 34 low, Water cooled: 245 hi, 34 low.
Metering device	TXV - 6 - 8°F. superheat
Compressor amps	8 -9
Gearmotor amps	3.1 - 3.5

**\* 90/70**

**B series: New water cooled condenser.**

## **NME950**

**HP62 (R-404A) model. Air, water or remote.  
Production from 1995 to 2000. There are 2 systems  
in a NME1850.**

Ice production	1080 - 625 lb/24 hr.
Air cooled water use*	94 gallons
Water use, water cooled condenser only	740 gallons
BTUs per hour	10500
Refrigerant type	R-404A
Refrigerant charge	Air cooled = 30 oz; Water cooled = 24 oz; Remote air cooled = 208 oz.
Refrigerant pressures	Air cooled: 255 hi, 35 low, Water cooled: 245 hi, 35 low.
Metering device	TXV, superheat 6 to 8°F.
Average amps	Compressor amps, 3 phase = 2.8; single phase = 4.3.

\* 90/70

**NME950RL production began in 1997.**

## NME954

**AutoSentry model. Air, water or remote. Production began in March 2000. There are 2 systems in a NME1854.**

Ice production	1080 - 625 lb/24 hr.
Air cooled water use*	94 gallons
Water use, water cooled condenser only	740 gallons
BTUs per hour	8500
RL BTUH for cond unit sizing	6000 - 5700
Refrigerant type	R-404A
Refrigerant charge	Air cooled = 30 oz; Water cooled = 24 oz; Remote air cooled = 208 oz.
Refrigerant pressures	Air cooled: 255 hi, 35 low, Water cooled: 245 hi, 35 low.
Metering device	TXV, superheat 6 to 8°F.
Average amps	Compressor amps, 3 phase = 2.8; single phase = 4.3.

\* 90/70

**B series: New water cooled condenser.**

## **NME1250**

**HP62 (R-404A) model. Air, water or remote.  
Production from October 1994 to March 2000.**

Ice production	1345 - 785 lb/24 hr.
Air cooled water use*	115
Water use, water cooled condenser only*	1025 gallons / 24 hrs
BTUs per hour*	13200
Refrigerant type	R-404A
Refrigerant charge	Air cooled = 36 oz; Water cooled = 24 oz; Remote air cooled = 208 oz.
Refrigerant pressures	250-210 high, 32 low
Metering device	TXV, superheat 6 to 8°F.

**\*90/70**

**Note: NME1250RL production began in 1997, uses 21" wide cabinet.**

## **NME1254**

**AutoSentry model. Air, water or remote. Production began in March 2000.**

Ice production	1345 - 785 lb/24 hr.
Air cooled water use*	115
Water use, water cooled condenser only*	1025 gallons / 24 hrs
BTUs per hour*	10000
RL BTUH for cond unit sizing	7250 - 7000
Refrigerant type	R-404A
Refrigerant charge	Air cooled = 36 oz; Water cooled = 24 oz; Remote air cooled = 208 oz.
Refrigerant pressures	250-210 high, 32 low
Metering device	TXV, superheat 6 to 8°F.

**\*90/70**

**B series: New water cooled condenser.**

## **NS650**

**Nugget ice maker with bin. Air or water cooled.  
Production began in 1989 and ended in 1994.**

Ice production	710 - 460 lb./24 hr.
Air cooled water use*	74 gallons per 24 hours
Water use, water cooled condenser only*	763 gallons per 24 hours
BTUs per hour*	9800
Refrigerant type	R-502
Refrigerant charge	Air cooled = 34 oz; Water cooled = 28 oz
Refrigerant pressures	250 - 220 high, 30 low
Metering device	TXV, superheat 6 to 8°F.
Average amps	14.3 - 16

**\*90/70**

**Changes: Black gearmotor and split phase drive motor.**



## **NSE650**

**Nugget ice maker with bin. Air or water cooled.  
Production from July 1994 to March 2000.**

Ice production	710 - 460 lb/24 hr.
Air cooled water use*	67 gallons
Water use, water cooled condenser only*	590 gallons
BTUs per hour*	6600
Refrigerant type	R-404A
Refrigerant charge	Air cooled = 25 oz; Water cooled = 20 oz
Refrigerant pressures	250 - 220 high, 33 low
Metering device	TXV, superheat 6 to 8°F.
Average amps	10

**\*90/70**

## **NSE654**

**AutoSentry Nugget ice maker with bin. Air or water cooled. Production began March 2000.**

Ice production	710 - 460 lb/24 hr.
Air cooled water use*	67 gallons
Water use, water cooled condenser only*	590 gallons
BTUs per hour	7000
Refrigerant type	R-404A
Refrigerant charge	Air cooled = 25 oz; Water cooled = 20 oz
Refrigerant pressures	250 - 220 high, 33 low
Metering device	TXV, superheat 6 to 8°F.
Average amps	10

**\*90/70**

**B series: New water cooled condenser.**

## SCE170

**Undercounter Cuber. Air or Water cooled.  
Production began in October 1994. Replaced the  
AC125.**

Ice production - high	165 lb at 70A/50W
Ice production - typical	110 lb at 90A/70W (AC)
Ice production - low	83 lb at 100A/90W (AC)
Air cooled water use*	60 gallons per 24 hr.
Water use, water cooled condenser only*	284 gallons per 24 hr.
BTUs per hour*	3000
Max harvest cycle time	7 minutes
Refrigerant charge (R-404A)	Air cooled = 17 oz; Water cooled = 9 oz
Refrigerant pressures	300 - 210 high, 25 low
Metering device	Internally equalized TXV, superheat 6 to 8°F.
Batch weight	1.6 to 1.8 lb
Cycle time	15 minutes at 70/50
	18 minutes at 90/70
Average amps	9

**\*90/70**

**Note: Control position changed July 1998. Hi pressure cut out changed from manual reset to auto reset in August 1998. B series began due to compressor change. C series: New water cooled condenser.**

## **SCE275**

**Undercounter Cuber. Air or Water cooled.  
Production began September 1997. Replaced AC25  
and AC30. CM<sup>3</sup> Technology.**

Ice production	305 to 180 lb/24 hr.
Air cooled water use*	64 gallons per 24 hr.
Water use, water cooled condenser only*	656 gallons per 24 hr.
BTUs per hour*	5500
Refrigerant type	R-404A
Refrigerant charge	Air cooled = 18 oz; Water cooled = 12 oz
Refrigerant pressures	300 - 225 high, 25 low
Metering device	Internally equalized TXV, superheat 6 to 8°F.
Batch weight	2.8 to 3.2 lb
Cycle time	17 at 70/50
	20 at 90/70
Average amps	6 - 7

**\* 90/70**

**Has two half-height evaporators in series. F series: New water cooled condenser.**

## **SLC300**

**22" cuber, air or water cooled. Fits SLB bins or SLD150 dispenser, also adapts to RS100 and IS100. Production began 1992, ended 1995.**

Ice production	290 lb./24 hr.
Air cooled water use*	30 gallons per 24 hours
Water use, water cooled condenser only*	339 gallons per 24 hours
BTUs per hour*	4500
Refrigerant type	R-502
Refrigerant charge	Air cooled = 15 oz; Water cooled = 16 oz
Refrigerant pressures	250 - 220 high, 20 low
Metering device	TXV
Batch weight	2.4 lb
Cycle time	13-16 minutes
Average amps	6-10

**\*90/70**

**SLC cubers use a float and siphon tube for water control.**

## **SLC400**

**22" cuber, air or water cooled. Fits SLB bins or SLD150 dispenser, also adapts to RS100 and IS100. Production began 1992, ended in 1995.**

Ice production	350 lb./24 hr.
Air cooled water use*	51 gallons per 24 hours
Water use, water cooled condenser only*	554 gallons per 24 hours
BTUs per hour*	6000
Refrigerant type	R-502
Refrigerant charge	Air cooled = 20 oz; Water cooled = 19 oz
Refrigerant pressures	250 - 220 high, 20 low
Metering device	TXV
Batch weight	3.8 lb
Cycle time	13-16 minutes
Average amps	7-11

**\*90/70**

## **SLE300**

**22" cuber, air or water cooled. Fits SLB bins or SLD150 dispenser, also adapts to RS100 and IS100. Production from 1995 to 2000.**

Ice production	290 - 220 lb./24 hr.
Air cooled water use*	35 gallons per 24 hours
Water use, water cooled condenser only*	307 gallons per 24 hours
BTUs per hour*	4500
Refrigerant type	R-404A
Refrigerant charge	15 oz
Refrigerant pressures	280 - 200 high, 20 - 25 low; Water Cooled = 270 PSIG
Metering device	TXV
Batch weight	2.4 lb
Cycle time	18-22 minutes

**\*90/70**

**Hot gas valve changed in March 1997, see PS-10-97.**

## **SLE400**

**22" cuber, air or water cooled, also remote air cooled. Fits SLB bins or SLD150 dispenser, also adapts to RS100 and IS100. Production from 1995 to 2000.**

Ice production	400 - 295 lb./24 hr.
Air cooled water use*	51 gallons per 24 hours
Water use, water cooled condenser only*	415 gallons per 24 hours
BTUs per hour*	6000
Refrigerant type	R-404A
Refrigerant charge	Air cooled = 19 oz; water cooled = 18 oz, remote = 136 oz.
Refrigerant pressures	220 - 370 high, 22 - 30 low; Water Cooled = 270 PSIG
Metering device	TXV
Batch weight	3.8 lb
Cycle time	16 - 17 minutes

**\*90/70**

**Remote is 208-230 volt.**

**Hot gas valve changed in March 1997, see PS-10-97.**



## **TDE470**

**New model in 1995, Touch Free version of the FDE470 flaker dispenser. Production discontinued June 2001.**

Ice production	470 to 280 lb./24 hours
Water use	49 gallons per 24 hours
BTUs per hour	7700
Refrigerant type	R-134a
Refrigerant charge	14 oz
Refrigerant pressures*	135 - 175 hi, 13-14 low
Metering device	Cap tube
Average amps	12.8 (vending)

**\* 90/70**

## **TDE550 or TDE650**

**Ice Maker - Dispenser. R-404A and Touch-Free dispensing. Production between in October 1994 and June 2001.**

Ice production	605 - 380 lb.
Water use, ice only*	56 gallons
Water use, water cooled condenser only*	558 gallons
BTUs per hour*	9200
Refrigerant type	R-404A
Refrigerant charge	Air cooled = 24 ounce Water cooled = 18 oz
Refrigerant pressures	250 - 220 high; 38 low. Water cooled discharge pressure should be 245 PSIG.
Metering device	TXV
Average amps	10 - 13

**\*90/70**

## **SLIM LINE**

### **Electrical Sequence**

**SLC or SLE cubers are controlled by three thermostats:**

- Ice thickness
- Harvest termination
- Bin level

**All must be in position and operate properly for the machine to function.**

**When the top row of cubes on the right side of the left evaporator fill out large enough to contact the ice thickness thermostat probe tube, the ice thickness thermostat switches the machine into the harvest cycle.**

**The machine stays in the harvest cycle until the suction line temperature warms up above 55°F. Then the harvest termination thermodisk switches the machine back into the freeze cycle.**

**If the bin thermostat opens it will shut the machine off immediately.**

**SLE Cubers differ in their control system. While they also operate from 3 thermostats, a complete cycle relay has been added to keep the machine on until the end of the next harvest cycle after the bin thermostat has sensed a bin full condition.**

## CUBER Operational Sequence

CM, HC, MC, and AC cubers have similar operational sequences. The length of the freeze cycle, and therefore the cube size, is controlled by a thermostat sensing suction line temperature. This thermostat is called the cube size control. When it closes on temperature fall, it connects power to a timer motor. The timer motor moves a cam which has a microswitch actuator riding on it.

When the timer's microswitch is pushed IN (by the high part of the cam) the micro-switch connects power to the relay in the circuit board. This is the freeze cycle.

Proper size and shape of a Scotsman Round Cube:

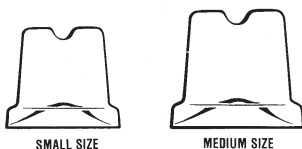

Note: Cubes not actual size

When the timer has rotated the cam far enough so that the low part of the cam releases the microswitch's actuator, power is cut from the coil of the relay and the unit goes into the harvest cycle. It stays in the harvest cycle until the timer pushes the microswitch actuator button in again. If the bin control is still closed, the machine will begin another cycle. If it is open, the ice machine will shut off.

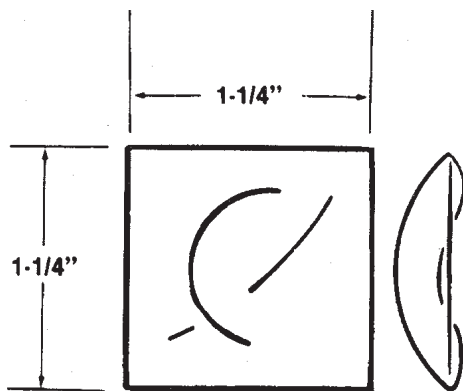

**Correct Size & Shape**

“CM” Cube Size

## CM<sup>3</sup> Operational Sequence

Electronic CM<sup>3</sup> Models, including CME256, CME306, CME456, CME506, CME656, CME686, CME806, CME810, CME1056, CME1356, CME1386, CME1656, CME1686, CME1856, CME2006, CME2086 and SCE275.

Common with all commercial cubers is a need to initiate a cube release cycle. The CM<sup>3</sup> takes in water in a batch and uses it to make ice; the measurement of how much of that water has been used during a freeze cycle is used to stop the freeze cycle and start the harvest cycle.

The harvest cycle continues until all ice has fallen. Ice falling is sensed with a electric eye set that, in some units, doubles as a bin control. The actual ice release time is used to set the next cycle's harvest time.

Cube size (larger than shown on prior page) is controlled by the float's stem. It is not adjustable.

Models	Float stem (stick) color	Float stem number on part	Cut in height*
CME256	WHITE	02-3383-01	2 1/4
CME306, CME456	DARK BLUE	02-3777-03	1 3/8
CME686	LIGHT GREEN	02-3777-02	1 5/8
CME810	LIGHT BLUE	02-3777-04	1 3/4
CME506, CME656 or CME806	GREY	02-3383-02	1 7/16
SCE275	BLACK	02-3383-03	1 1/4
CME1056	SILVER	02-3777-01	1 3/16
CME1356	TAN	02-3383-04	2 1/8
CME1386	Dark Blue	02-3383-07	1 3/4
CME1656	BROWN	02-3383-05	1 3/4
CME1686	Light Green	02-3383-08	1 5/8
CME1856, CME2006	RED	02-3383-06	1 5/8
CME2086	Light Blue	02-3383-09	1 5/8

\* Amount of stem, in inches, above sensor body when harvest is triggered.

## **CM<sup>3</sup> Operational Sequence - CME256, CME506, CME656, CME806 and SCE275**

From Off, push and release the Freeze button

1. If sump is full, water pump starts. If sump is not full, water valve opens to fill it.
2. Compressor starts when sump is full. Air cooled fan motor starts too.
3. Water pump stops early in freeze cycle for 30 seconds.
4. Sump refills after pump restarts.
5. In low ambient condition, fan motor may begin to cycle on and off.
6. Freeze continues until water level in sump drops to preset point. Exception: SCE275 must fill sump two more times.
7. Fan may shut off before the end of freeze.
8. Harvest begins. Hot gas valve opens, pump stops.
9. Pump restarts, inlet water valve opens to fill and overflow the reservoir.
10. Harvest continues for preset first cycle harvest time.
11. If bin is not full, cycle repeats (compressor stays on). If bin is full, unit shuts off at the end of harvest.

## **CM<sup>3</sup> Operational Sequence - CME306, CME456, CME1056, CME1356, CME1656, CME1856, CME2006**

From Off, push and release the Freeze button

1. Purge valve opens, pump starts, sump emptied.
2. Purge valve closes.
3. Inlet water valve opens, fills sump.
4. Compressor starts when sump is full. Air cooled fan motor starts too.
5. Water pump stops early in freeze cycle for 30 seconds.
6. In low ambient condition, fan motor may begin to cycle.
7. Freeze continues until water level in sump drops to preset point for the second time. Exception: on the CME306 the first drop in water level triggers harvest.
8. Fan may shut off before the end of freeze.
9. Harvest begins. Hot gas valve opens, purge valve opens, pump stops. Remote models open the harvest bypass valve for a few seconds.
10. Pump restarts, sump is drained.
11. Pump stops, inlet water valve opens to add water to the sump - but not fill it.
12. Harvest continues for preset first cycle harvest time.
13. If bin is not full, cycle repeats, beginning with step 3 (compressor stays on). If bin is full, unit shuts off at the end of harvest.

## SCE170 Operational Sequence

This cuber's freeze cycle is controlled by a cube size thermostat. This thermostat senses suction line temperature and closes on temperature fall.

When the cube size thermostat closes, the upper light on the control board is switched on and an internal timer in the control board finishes the cycle.

When harvest is initiated, the fan shuts off and the hot gas and purge valves open. The SCE170 stays in harvest until either the curtain opens or 7 minutes have passed.

When the curtain re-closes, the unit returns to a freeze cycle. If the curtain remains open, the machine shuts off.

"Dimple" Must NOT Be  
DEEPER than  $\frac{1}{16}$ "

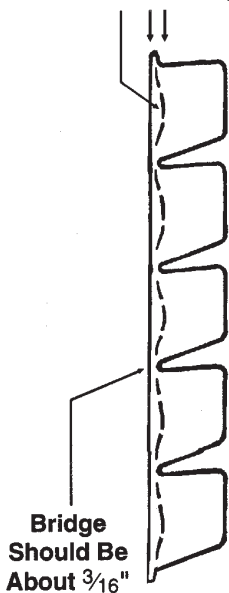

JUST RIGHT



## Superheat

In a mechanical refrigeration system, superheat is the amount the evaporator outlet's temperature is warmer than the temperature equivalent of the refrigerant's pressure in the evaporator. Too much superheat is a symptom of low charge or a TXV starving the evaporator, and likely overheating the compressor. Too little is a symptom of a TXV flooding through and overcooling the compressor.

Testing has shown that superheat is usually not a constant number. It changes both during the freeze cycle of a cuber and as the thermostatic expansion valve modulates or hunts. An accurate measurement of superheat requires several sample measurements of TXV bulb temperature and suction pressure.

The recommended frequency of measuring is every 15 seconds. Start 5 minutes into a freeze cycle.

Set up a table like this to record the information.

Freeze Cycle Time	15 sec	30 sec	45 sec	60 sec	Average
1. TXV bulb temp					n/a
2. Suction Pressure					n/a
3. Suction pressure converted to temperature					n/a
Superheat (1-3)					

Record data in rows 1 and 2. Convert row 2 to temperature and record it in row 3. Subtract row 3 from row 1 and enter the data in the superheat row. Calculate the average superheat.

This example is only for one minute's operation. Five minute's operation will give a more accurate reading.

**Note:** Thermometer attachment and insulation is critical in obtaining accurate readings.

## Electrical Suffix Code

CODE	VOLTAGE	CYCLES	PHASE
-1	115	60	1
-2	230	60	1
-3	208-230*	60	3
-4	115/230**	60	1
-6	230	50	1
-7	208	60	1
-9	115/208-230**	60	3
-10	115/208**	60	1
-31	115/208-230**	60	1
-32	208-230*	60	1

**\*Two voltages separated by a hyphen (-) means that the machine can operate between the two voltages.**

**\*\*Two voltages separated by a slash (/) means that both voltages are required to operate the machine. Usually requires a neutral wire.**

## Scotsman Model Identification:

General Example: CME506AS-1F

CME	506	A	S	-1	F
Type	Relative Size	Cond. Type	Finish	Elec.	Series

Ice Maker Dispenser Example: MTD5N25AS-1B

MD	T	5	N	25
Type	Disp Type	Rel Size	Ice Type	Bin Size

### Type:

- CME is a Modular Cuber; (the “E” here means either R-404A or R-134a refrigerant. CME506 uses R-404A).
- MD is an ice Maker Dispenser

### Relative Size:

- 506 ranks the unit by ice production: CME506 makes more ice than a CME256, but less than a CME656.
- Ice maker dispenser: a 3 has less ice production than a 4

### Dispenser Type

- T - Touch Free, L - Lever

### Cond Type:

- A means air cooled
- W means water cooled
- R means remote air cooled
- RL means remote low side

### Ice Type

- N = Nugget
- F = Flake
- C = Cubelet

### Finish:

- E means painted (enamel), no longer used
- S means stainless steel (all are S beginning in 2000)

### Bin Size:

- Rated/calculated dispenser capacity in pounds

### Electrical:

- -1 means 115 volt, see prior page for more info.

### Series:

- and F means 6th design series.

Other models are similar, “finish” is not used on molded cabinet models, such as SCE170. Older cubers listed an “S” or “M” after the relative size number for Small or Medium cube.

# Remote Systems

## Headmaster

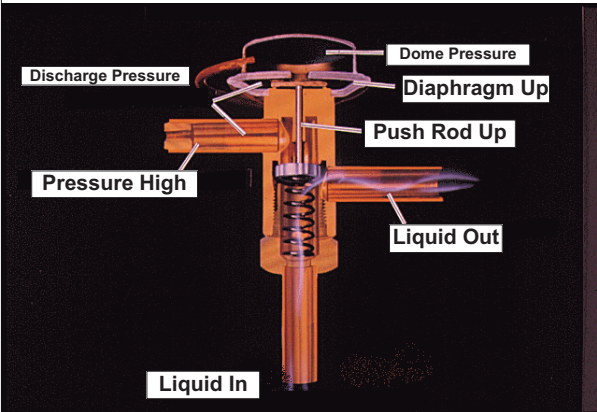

Normal operation. System discharge pressure is higher than the sealed dome's pressure and the diaphragm is forced up, allowing the valve seat to open the liquid line.

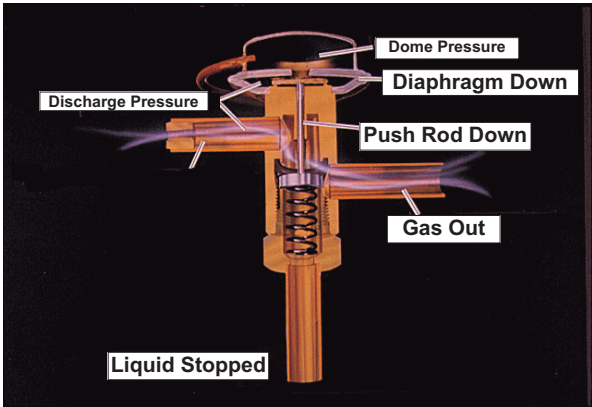

Low temperature operation. System discharge pressure is lower than the sealed dome pressure. The diaphragm then forces down the push rod which closes the liquid

## CM<sup>3</sup> Cuber Controller

The Controller on the CM<sup>3</sup> cuber is capable of providing the service technician with a guide toward possible problems thru the use of indicator lights. The diagnostic codes indicate machine problems, not controller faults.

<b>If the machine is Off and the</b>	<b>This Could Be the Cause</b>
Water Diagnostic Light blinks <u>one time and repeats</u>	Water Pump not pumping
Water Diagnostic Light blinks <u>2 times and repeats</u>	Water does not fill reservoir
Water Diagnostic Light is on <u>without blinking</u>	Water valve leaking thru (a lot)
Refrigeration Diagnostic Light blinks <u>one time and repeats</u>	Maximum length harvest cycle use, ice sensed.
Refrigeration Diagnostic Light Blinks two times and repeats	Maximum length harvest cycle use, no ice sensed.
Refrigeration Diagnostic Light blinks <u>3 times and repeats</u>	Discharge temperature too high
	Fan motor failed (in high ambients)
Refrigeration Diagnostic Light is on <u>without blinking</u>	Maximum length freeze cycle
Bin Full Light is ON	Bin is full, ice sensors blocked.
<b>If the machine is On and</b>	<b>This Could Be the Cause</b>
Both Error lights are on <u>continuously</u> , the machine is still making ice.	Discharge or Water temperature sensor failure
the refrigeration diagnostic light is on <u>continuously</u> , the machine is still making ice	Water temperature did not fall properly in the freeze cycle

# Hermetic Compressor Diagnostics

There are three basic conditions that a DEFECTIVE compressor might have.

1. Is totally silent - no pumping.
2. Makes a humming noise, but does not pump.
3. Runs, pumps but has other operational problems.

## Symptom

### *Possible Cause*

#### Check

## Totally Silent

*Control system not supplying power to the compressor*

Check power to the compressor. If none, check fuse, breaker, ice machine control system, and contactor.

*Motor Overload is open because the compressor motor overheated.*

Check temperature of the compressor dome. and check for an open circuit in the compressor. If hot, see "overheats"

*Motor overload is open, possibly because starting components have failed.*

If there is power, is there power to the start winding? If not, check the start capacitor and start relay.

*Overload has failed in the open position*

Check temperature of compressor dome and check for open circuit in the compressor. If hot, see "overheats".

*Compressor motor has open winding*

Check the windings of the compressor for an open circuit.

# Hermetic Compressor Diagnostics

## Hums, but does not pump

*Starting components have failed*

Check the start capacitor and start relay

*Locked rotor*

Check the starting components and compressor windings

*Motor may be running, but the valves do not seal or the pistons do not move*

Check amp draw and system pressures

*Wired wrong*

Check wiring of capacitor(s) and relay

*Low voltage at compressor*

Check voltage at compressor before and during attempted start

## Runs and pumps but has other operational problems

*Noise*

Internal parts are worn

Internal mounting springs/supports have failed

Compare to new system

*High Amps*

Bearings are worn

Check amp draw, high amps may indicate worn bearings

Winding partially shorted

Check resistance of motor

Run capacitor inoperative

Check run capacitor

# Hermetic Compressor Diagnostics

## Runs and pumps but has other operational problems

### *Low Capacity*

#### Valve Leak

Check amp draw, low amps may indicate leaking compressor valves **or** low charge

Other causes for long freeze cycles include: hot gas valve leaking thru, dirty condenser, plugged filters, inlet water valve leaking thru, TXV with too much superheat.

### *Overheats*

Lack of refrigerant/too much superheat

Check system, check TXV bulb mounting

Worn internal parts

Check amp draw, high amp draw may indicate worn parts

Start system problem

Check starting components, voltage and wiring

Winding partially shorted

Check resistance of motor

Discharging gas into dome of compressor

Check system pressures, if discharge is over 450 PSIG, internal relief valve may have opened. Check system. Check high pressure cut out.

### *Too quiet, too cold*

Not enough superheat, overcharged

Check system, check TXV bulb mounting



# Hot Gas Valves

## Design

Hot gas valves are selected by flow rate, coil voltage and tubing size for each refrigeration system. Flow rates that are too small will extend the harvest cycle, while flow rates that are too large may cause excessive refrigerant flow to the compressor. When replacing a complete valve do NOT use anything other than the OEM valve specified for the model in question. Rebuild kits are available for those valves without seat damage.

## Diagnosis

Most hot gas valves are pilot type valves: Activation lifts a plunger that relieves pressure above the main valve disk allowing the main valve disk to lift up, allowing full flow of gas.

Valves can fail in three ways:

1. Do not open.
2. Leak through when closed (freeze cycle).
3. Do not open fully.

**Do not open:** When a valve does not open in the harvest cycle the power to the valve coil should be the first thing to check. If the proper voltage is present, check the coil for continuity.

**Leaks through when closed:** This can be caused by contamination on the seat of the valve. The degree of leak through can vary greatly. A good valve will have some temperature differential between its inlet and outlet during freeze and frost will gradually build up on the tubing leading from the evaporator inlet to the gas valve.

**A leaking valve will cause the body of the valve to stay hot during the freeze cycle.**

**Does not open fully:** This can be caused by a stuck disk in the valve. The coil pulls up the plunger and the valve opens, but ice release is slow. Another symptom of this is very low suction pressure during harvest and lack of heat at the evaporator inlet.

# Kits

**Harvest Extender Kit: Fits CMS1202, CME1202, CMS1402 and CME1402, Part number: A37281-020**

## Water Valve Repair Kit (no coil or frame)

- White body valves: 12-2636-20
- Blue body valves: 12-2912-01
- Water regulating valves: 11-0559-01 (3/8" only)

## Hot Gas Valve Kits (Alco only)

Model	Valve Complete	Coil Part Number	Rebuild Kit Part Number
CME250	12-2417-21	12-2719-21	12-2733-30
CME500	12-2417-22		
SCE170	11-0475-21		12-2733-20
CME1402, CME1202,	11-0495-21	12-2719-22	12-2733-30
CME1202R, CME1402R	11-0494-21		
CME650	12-2417-23		
CME865, CME855	11-0493-21		
CME1002, CME1000	11-0491-21		
CME256, SCE275, CME306	12-2471-21		
CME456, CME506, CME686	12-2471-22		
CME656	12-2471-23		
CME806, CME1056	12-2471-24		
CME1356, CME1656, CME1386	11-0507-21		
CME1686, CME2006	11-0507-22		
CME810, CME2086	11-0507-23		

## Ice Storage Bin Doors

Parts identification usually requires an accurate model number. However, it is sometimes difficult to locate the model and serial number of an ice storage bin. This table is intended to identify the model of the bin by the size of the bin door. It applies to Scotsman brand bins only.

Length	Width	Bin Model
21	11 ¼	SLB150/260
21	15	SLB375
22 ¼	16 ¼	B90 or BX87
29 ¼	15 ¼	B350
29 ¾	19 ½	HTB555
30 ¼	11 1/4	HTB250/350/500
30 ¼	15 ½	BH550
32 ½	19 ¾	B80 (1 door) or B120 (2 doors)
42	15 ½	BH800
42 ½	11 ¼	B40 or B60
44	16	BH1370
44 ¼	15 ½	BH1351/1352/1360
47 1/2	14 ¾	BH900
47 1/2	15	BH900C
49 ½	15	BH1000
51	15	BH1000C
52	13	BH750
52	15 ½	BH1000A

# Inlet Water Valves

Scotsman uses several different inlet water valves.

All have a screen on the inlet.

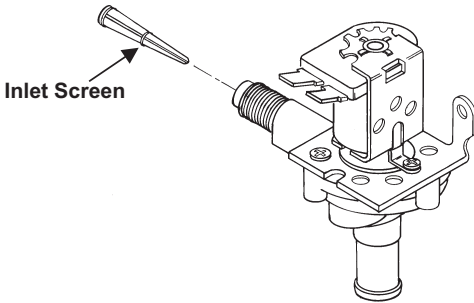

If the water flow into the cuber is below what is listed for the model in question, the water valve's screen may need to be cleaned. On the valve pictured above, the inlet fitting will have to be removed to get to the screen. A sheet metal screw turned partially into the screen may be used to pull the screen out.

Inlet water valves should not be operated without the screen.

*Inlet Water Valve  
(Blue CME Type)*

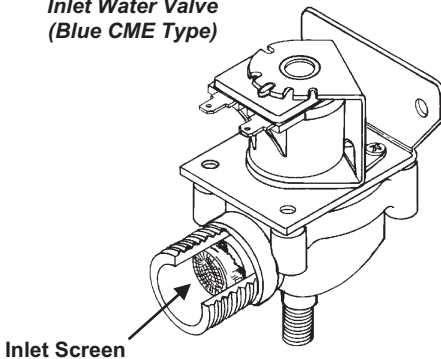

# Cuber Capacity Check

## 1. Check cube size - is it correct?

- CM, CMS, CME, SCE275 type: Harvests in vertical strips
- AC, MC, HC, CS55, CS60 type: Full cubes with a dimple in the bottom.
- SCE170 type: Harvests as a sheet - 3/16" bridge, 1/16" dimple.

## 2. Check ice formation pattern - is it even?

- Must make ice over all freezing surfaces - nearly evenly.

## 3. Measure water temperature to ice machine.

## 4. Measure air temperature

- Air cooled check air temp into the coil
- Water cooled check ambient air

## 5. Operate the machine for 2 cycles and then measure the total cycle time (freeze + harvest). Compare to the cycle time in the manual or this book for the air and water temperatures the ice machine is operating in.

- 90/70 = 90°F. air temp and 70°F. water temp.
- 70/50 = 70°F. air temp and 50°F. water temp.
  - Temperatures above will cause longer cycles
  - Temperatures below will cause shorter cycles
  - Temperatures in between will result in cycle times between 90/70 and 70/50 times.

## 6. If total cycle time is within a minute or two of what is listed in the machines's service manual for the temperatures the unit is in, the capacity is normal.

**Note: Harvest times set for winter operation (for those units with adjustable harvest times) will extend the total cycle beyond normal.**

# Refrigerant Temperature-Pressure Chart

TEMP...	R-12	R22	R502	R-404A <sup>^</sup>	HP81 <sup>^</sup>
-14.	2.8	13.8	19.5	21.1	19.6
-12.	3.7	15.1	21.0	22.6	21.1
-10.	4.5	16.5	22.6	24.2	22.7
-8.	5.4	17.9	24.2	25.9	24.4
-6.	6.3	19.3	25.8	27.6	26.1
-4.	7.2	20.8	27.5	29.3	27.8
-2.	8.2	22.4	29.3	31.1	29.7
<b>0.</b>	<b>9.2</b>	<b>24.0</b>	<b>31.1</b>	<b>33.0</b>	<b>31.5</b>
1.	9.7	24.8	32.0		
2.	10.2	25.6	32.9	34.9	33.5
4.	11.2	27.3	34.9	36.9	35.5
6.	12.3	29.1	36.9	39.0	37.5
8.	13.5	30.9	38.9	41.1	39.6
10.	14.6	32.8	41.0	43.3	41.8
11.	15.2	33.7	42.1		
12.	15.8	34.7	43.2	45.5	44.1
14.	17.1	36.7	45.4	47.8	46.4
15.	17.7	37.7	46.5		
16.	18.4	38.7	47.7	50.2	48.8
18.	19.7	40.9	50.0	52.7	51.2
19.	20.4	41.9	51.2		
20.	21.0	43.0	52.5	55.2	53.8
22.	22.4	45.3	54.9	57.8	56.4
23.	23.2	46.4	56.2		
24.	23.9	47.6	57.5	60.4	59.1
26.	25.4	49.9	60.1	63.2	61.8
27.	26.1	51.2	61.5		
28.	26.9	52.4	62.8	66.0	64.6
30.	28.5	54.9	65.6	68.9	67.5
31.	29.3	56.2	67.0		
<b>32.</b>	<b>30.1</b>	<b>57.5</b>	<b>68.4</b>	<b>71.8</b>	<b>70.5</b>
33.	30.9	58.8	69.9		
34.	31.7	60.1	71.3	74.9	73.6
36.	33.4	62.8	74.3	78.0	76.7
38.	35.2	65.6	77.4	81.3	80.0
40.	37.0	68.5	80.5	84.6	83.3
42.	38.8	71.5	83.8	88.0	86.7
44.	40.7	74.5	87.0	91.4	90.2
46.	42.7	77.6	90.4	95.0	93.8
48.	44.7	80.8	93.9	98.7	97.4
50.	46.7	84.0	97.4	102.4	101.2
60.	57.7	101.6	116.4	125.1	127.4
70.	70.2	121.4	137.6	148.2	150.6
80.	84.2	143.6	161.2	174.0	176.5
90.	99.8	168.4	187.4	202.9	205.2
100.	117.2	195.9	216.2	235.1	237.1
110.	136.4	226.4	247.9	270.8	272.2
120.	157.7	259.9	282.7	310.3	310.9
130.	181.0	296.8	320.8	353.9	353.2
140.	206.6	337.3	362.6	401.9	399.5
150.	234.6	381.5	408.4	454.5	449.9

<sup>^</sup><50°F = Sat. Vapor >50°F. = Sat. Liquid.

# CM<sup>3</sup> Thermistor Values

Temp (F°)	Resistance (ohms)	Temp (F°)	Resistance (ohms)	Temp (F°)	Resistance (ohms)
0	85325	44	23394	88	7685
1	82661	45	22767	89	7507
2	80090	46	22159	90	7333
3	77607	47	21569	91	7164
4	75210	48	20997	92	6999
5	72896	49	20442	93	6839
6	70660	50	19903	94	6683
7	68501	51	19381	95	6530
8	66415	52	18873	96	6382
9	64400	53	18381	97	6238
10	62453	54	17903	98	6097
11	60571	55	17439	99	5960
12	58752	56	16988	100	5826
13	56995	57	16551	101	5696
14	55296	58	16126	102	5569
15	53653	59	15714	103	5446
16	52065	60	15313	104	5325
17	50529	61	14924	105	5208
18	49043	62	14546	106	5093
19	47607	63	14179	107	4981
20	46217	64	13823	108	4872
21	44872	65	13476	109	4766
22	43571	66	13139	110	4663
23	42313	67	12812	111	4562
24	41094	68	12494	112	4463
25	39915	69	12185	113	4367
26	38774	70	11884	114	4273
27	37669	71	11592	115	4182
28	36600	72	11308	116	4093
29	35564	73	11031	117	4006
30	34561	74	10763	118	3921
31	33590	75	10502	119	3838
32	32649	76	10247	120	3757
33	31738	77	10000	121	3678
34	30855	78	9760	122	3601
35	30000	79	9526	123	3526
36	29171	80	9299	124	3452
37	28368	81	9077	125	3381
38	27589	82	8862	126	3311
39	26835	83	8652	127	3243
40	26104	84	8448	128	3176
41	25395	85	8250	129	3111
42	24707	86	8056	130	3047
43	24041	87	7868	131	2985

## CM<sup>3</sup> Thermistor Values

Temp (F°)	Resistance (ohms)	Temp (F°)	Resistance (ohms)	Temp (F°)	Resistance (ohms)
132	2924	175	1279	218	616
133	2865	176	1256	219	606
134	2807	177	1234	220	597
135	2751	178	1212	221	587
136	2696	179	1190	222	578
137	2642	180	1169	223	569
138	2589	181	1149	224	560
139	2537	182	1129	225	551
140	2487	183	1109	226	543
141	2438	184	1090	227	534
142	2390	185	1071	228	526
143	2343	186	1052	229	518
144	2297	187	1034	230	510
145	2252	188	1016	231	502
146	2208	189	998	232	495
147	2165	190	981	233	487
148	2123	191	965	234	480
149	2082	192	948	235	472
150	2042	193	932	236	465
151	2003	194	916	237	458
152	1965	195	901	238	451
153	1927	196	885	239	444
154	1890	197	871	240	438
155	1855	198	856	241	431
156	1819	199	842	242	425
157	1785	200	828	243	419
158	1752	201	814	244	412
159	1719	202	800	245	406
160	1687	203	787	246	400
161	1655	204	774	247	394
162	1624	205	761	246	389
163	1594	206	749	249	383
164	1565	207	737	250	377
165	1536	208	724		
166	1508	209	713		
167	1480	210	701		
168	1453	211	690		
169	1427	212	679		
170	1401	213	668		
171	1375	214	657		
172	1350	215	646		
173	1326	216	636		
174	1302	217	626		



## Sonar

Sonar is used as an ice level control on several Scotsman Cubers:

### Models using 4 position control:

- MCM860
- MCM1062
- MCM1462

### Models using 2 position control

- CMS1002
- CMS1202
- CMS1402
- CME865
- CME1002
- CME1202
- CME1402

Sonar will shut the ice machine off when the ice level builds up to the point where it is within the selected distance from the transducer, located in the base of the ice machine.

Selection is controlled by a switch, either a 4 position rotary switch or a 2 position rocker switch.

On the board is a 5 pin connection point for the switch. The pins are numbered 1 thru 5. 5 is common. A connection between a pin (1-4) and 5 determines the shut off point.

Pin Connections	Shut-Off Distance	Setting
1 (W) to 5 (BK)	9 ¾" to 12"	Full
2 (R) to 5 (BK)	15" to 16"	¾
3 (BU) to 5 (BK)	22" to 23"	½ (or Partial)
4 (Y) to 5 (BK)	30" to 31"	¼

**12-2402-01 is the harness for the two position switch.**

**The 4 position switch includes its harness.**

## Compressor Potential Relays

The part number prefix for a Scotsman compressor start relay is 18-1903, the ending numbers identify the individual part's configuration.

Part Number	Pick-Up Volts	Drop Out Volts	Continuous Voltage Rating	Hz
18-1903-04	150-160	20-55	130	60
18-1903-18	340-360	55-125	336	60
18-1903-21	320-340	60-140	395	60
18-1903-22	300-320	60-133	336	50
18-1903-26	320-340	75-160	420	60
18-1903-28	260-280	75-150	420	60
18-1903-29	240-260	60-140	395	60
18-1903-30	280-300	60-140	336	50
18-1903-31	170-180	45-90	256	60
18-1903-33	190-200	55-115	332	60
18-1903-34	300-320	75-160	420	60
18-1903-35	190-200	60-124	336	50
18-1903-40	170-180	40-90	336	60
18-1903-44	150-160	45-90	256	60
18-1903-46	190-200	60-130	395	60
18-1903-47	300-320	60-140	395	60
18-1903-50	210-230	75-150	420	60
18-1903-52	170-180	55-115	332	60
18-1903-53	160-170	35-77	228	50
18-1903-54	240-260	60-140	395	60
18-1903-55	160-170	40-90	332	60
18-1903-56	240-260	60-121	337	50
18-1903-57	190-200	55-115	332	60

## Start Capacitors

The part number prefix for a Scotsman start capacitor is 18-1901, the ending numbers identify the individual part's configuration.

Part Number	MFD	VAC
18-1901-03	124-149	220
18-1901-04	324-389	110
18-1901-09	161-193	220
18-1901-12	540-648	110
18-1901-15	145-174	220
18-1901-20	108-130	330
18-1901-23	130-156	330
18-1901-27	189-227	330
18-1901-33	189-227	220
18-1901-40	88-109	250
18-1901-41	378-455	135
18-1901-42	270-324	160
18-1901-43	61-72	250
18-1901-45	88-106	330
18-1901-47	282-340	110
18-1901-48	145-174	250
18-1901-49	243-292	110
18-1901-50	145-174	250
18-1901-51	108-130	250
18-1901-52	130-156	250
18-1901-53	88-106	220
18-1901-54	108-130	220
18-1901-55	72-88	250
18-1901-56	72-88	330
18-1901-57	64-77	330
18-1901-58	270-324	330

## Run Capacitors

The part number prefix for a Scotsman run capacitor is 18-1902, the ending numbers identify the individual part's configuration.

Part Number	MFD	VAC
18-1902-17	10	370
18-1902-27	40	440
18-1902-28	30	440
18-1902-29	20	370
18-1902-30	15	440
18-1902-45	25	370
18-1902-51	35	370
18-1902-52	15	370
18-1902-53	30	370
18-1902-55	35	370
18-1902-56	40	370
18-1902-57	45	370
18-1902-58	50	440
18-1902-59	60	370

# CM<sup>3</sup> Purge Adjustment

Adjust by using the push buttons on the Controller.

1. If the machine is on, push and hold the OFF button for more than 3 seconds, then release it.
2. Push and hold the OFF button for more than 3 seconds (just until all LEDs flash on) then release it. Do not hold it in it too long.
3. Examine the green LEDs. They should have all flashed once, then certain ones will have turned on to indicate which purge level the machine is set at.

There are 5 levels of purge available:

- **Maximum** is when All 5 lights are ON. Use for extreme water conditions. Note: This setting may extend the Harvest cycle and reduce capacity.
- **Heavy** is when these 4 lights are ON: Freeze, Harvest, Clean, Off. Use for moderate to severe water conditions. This setting may extend the Harvest cycle and reduce capacity.
- **Standard** (factory setting) is when these 3 lights are ON: Harvest, Clean, Off. Use for typical water conditions.
- **Moderate** is when these 2 lights are ON: Clean, Off. This is for good water conditions.
- **Minimum** is when this 1 light is ON: Off. For excellent water conditions.

Adjust by pushing and releasing the Freeze button. Each push and release increases the purge one level up to the maximum, one more changes it to the minimum.

4. The machine will automatically restart after 60 seconds of no switch inputs, or restart the machine by pushing in and holding the Off button for more than 3 seconds, then releasing it. The unit will then be Off. The machine may now be placed in a freeze cycle by pushing and releasing the Freeze button.

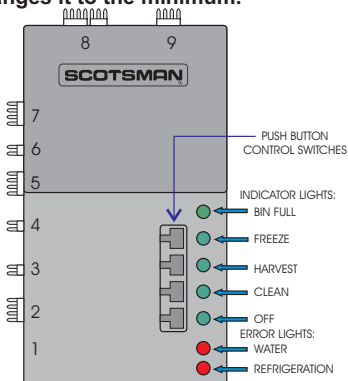

## **CM<sup>3</sup> - Blue Controller**

### **Diagnostic Code Recall**

**When the controller encounters a condition in the operation of the ice machine that may be an indicator of a problem, such as a very long freeze time, it displays a problem code with the Diagnostic Indicator Lights. However, if the user resets the controller to get back in operation, the code is no longer displayed, and with the black controllers, it could not be recalled.**

**That has changed with the blue controller. The last two error codes, if any exist, can be recalled.**

**To recall the last error codes:**

**1. Switch the unit Off by holding the Off button in for longer than 3 seconds.**

**2. Hold the Off button down again until the Purge Setting indicators (Green Lights) are on.**

**3. Push and release the Harvest button.**

- **The last error code (if any) will be displayed and the purge setting code will disappear.**

**4. Push the Harvest button again and the second-to-last error code AND the Bin Full light will be displayed. Only two error codes are available for display.**

- **If no error code exists, no code will be displayed and there will be NO LIGHTS showing.**
- **Pushing Harvest again will toggle back to the last error code and the bin full light will go out.**
- **Pushing it again will toggle back to the second-to-last error code and also switch on the Bin Full light.**

**5. To return from the display of the last error, do nothing for 60 seconds or push and hold the Off button until the off light glows.**

**After returning from the display of the last error (Off light is on), the machine may be returned to the ice making process by pushing and releasing the Freeze button.**

## CM<sup>3</sup> Water Level Sensor Diagnostics

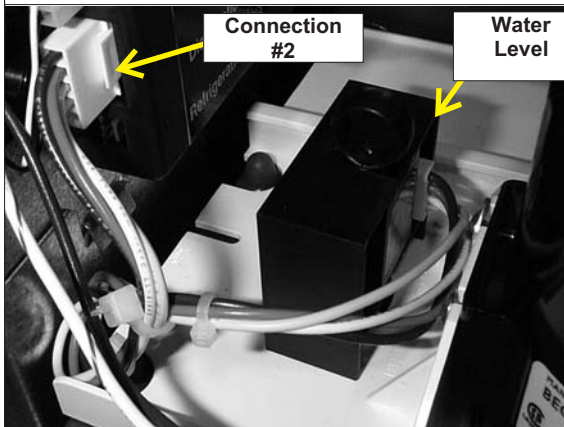

1. Confirm that at least one light on the board is glowing. If not, check the power and/or transformer. Push and hold the Off button until the machine stops.

2. Unplug water sensor harness from controller (connection #2).

3. Set the voltmeter to DC and use a scale low enough to measure less than 40 Volts.

4. Measure the voltage between the top and the bottom pins on the controller at connection #2 (the bottom is ground or negative).

- Normal (unplugged): Black controllers - 24 to 30 VDC.  
Blue controllers - .5 to 2 VDC

If the reading is low, check the power supply to the controller or the controller itself. If it is roughly 24 - 30 V proceed to the next step.

5. Reconnect the harness. Be SURE it is on properly and has a good connection. To confirm, unplug the harness from the water sensor and redo step #4 at the end of the harness. Then plug the harness back onto the sensor.

## Harness Connected Voltage (DC)

**6. At the controller, measure the voltage between the top and bottom pins on connection #2. This should be between 2 and 3.5 VDC. If it outside this range there is a problem in the sensor and it should be changed out. If it is within this range, proceed to the next step.**

- Blue to Yellow (plugged in): Black controllers - 2 to 3.5 VDC. Blue controllers - .4 to 2 VDC.

**7. Place negative voltmeter probe on the bottom terminal (yellow wire). Place the other on the one just above it (terminate freeze sender - white wire). Move the float stem/stick up and down and note the voltage changes. It should change from between about 5 VDC as the light is blocked (higher) to a lower reading when un-blocked. If it does not change, the sensor may be dirty or has failed. Remove the dust cover from the sensor to clean it.**

**Note: The sensor must be properly assembled. The terminals of the sensor must be in the lower right corner. If they are in the upper left remove the sensor's dust cover and reverse the board.**

	Yellow (bottom) Black controllers	Blue controllers
White - Blocked	4 to 5 VDC	about 5 VDC
White - Unblocked	<1 VDC	less than when blocked

**8. With the voltmeter probe still on the bottom terminal (of #2), place the other one on the second pin from the top ( red wire). Move the float stick up and down, note the changes in voltage. It should react the same as in step 7.**

	Yellow (bottom) Black controllers	Yellow (Blue controllers
Red - Blocked	4 to 5 VDC	about 5 VDC
Red - Unblocked	<1 VDC	Less than when blocked

**9. If all voltages check out, there is nothing wrong with the sensor or the voltage it receives from the controller.**



## **Warranty Summary**

**Scotsman's commercial warranty varies by product type, country, and model prefix or model number.**

- All cubers (CS60, CSE60, CME, SCE) BH and SLB bins, CD200, HD and SLD dispensers have 3 years labor, 3 years parts, plus CME, SCE, SLE, and SLC evaporators are covered for 5 years parts and labor and their condensers and compressors have 5 years parts.
- BH1100, BH1300, BH1600, BH1366, BH1666 and HTB bins have 5 years parts and labor.
- ID, RS and IS dispensers have 1 year labor and 2 years parts.
- CSW45 has 1 year parts and labor.
- AutoSentry Flakers, NME654, NME954, NME1254, NME1854, FME804, FME1204, FME1504, FME2404 have three years parts, three years labor and 5 years on the compressor (parts).
- MAR industrial flakers have three years parts and labor plus 10 years parts on the evaporator drum and refrigerant seal kit

**All other products have two years parts, two years labor and 5 years on the compressor (parts).**

**See warranty statements for specific information.**

## Date Code Chart

Scotsman's production date code is located in the serial number. The code is month & year. From 1972 to May 2004 this date code system was used.

### Month Code:

January = 07

July = 01

February = 08

August = 02

March = 09

September = 03

April = 10

October = 04

May = 11

November = 05

June = 12

December = 06

### Year Code:

1972 = N

1984 = U

1996 = A

1973 = A

1985 = G

1997 = N

1974 = P

1986 = V

1998 = B

1975 = B

1987 = H

1999 = P

1976 = Q

1988 = W

2000 = C

1977 = C

1989 = J

2001 = R

1978 = R

1990 = X

2002 = D

1979 = D

1991 = K

2003 = S

1980 = S

1992 = Y

2004 = E

1981 = E

1993 = L

2005 = T

1982 = T

1994 = Z

2006 = F

1983 = F

1995 = M

2007 = U

For example, if a serial number is 999999-07Y, the 07Y is the date code (January 1992).

Machines manufactured after May 2004 use a different code:

2 digit Year, 2 digit Month, mfg/site ID, six numbers



Example: **04061320998877**

**0406 = Manufactured June, 2004**

## **CM<sup>3</sup> Controller Revision (3 pages)**

Rev 9 controllers (use began 2/05) provide a new diagnostic procedure that checks two functions of the controller:

1. In sequence, all the controller's relays are switched on for a certain time to confirm that power is going to the component and that the component is operating.
2. At the end of that test the water level sensor is checked. The green light display on the controller changes as the float stem is manually moved up and down in the sensor.

### **Component Test Sequence:**

1. **Water inlet valve test.** Verifies that the water inlet solenoid valve opens and water fills the sump. Some water may overflow into the bin.
2. **Water Pump test.** With water in the sump from the prior test, the pump starts and circulates water.
3. **Purge valve test.** Purge valve opens to discharge water. No effect on overflow models.
4. **Compressor test.** Compressor starts, hot gas valve open for short time.
5. **Harvest bypass valve test.** Compressor on, check valve remote systems verify that the harvest by-pass valve opens.
6. **All off test.** Verifies that the relays open.
7. **Hot gas valve test.** Verifies that the hot gas valve opens.
8. **Fan motor test.** The fan motor is switched on to verify its operation.

### **To start the diagnostic process**

1. Push and hold the off button until the unit shuts off.
2. Push and hold the off button again until the Purge indicator lights (green lights) switch on.
3. Push and hold the clean button until the bin full light starts to blink, that starts the diagnostic. The test will begin and end automatically.

## Component Test

If all the components operate as listed below, the controller passed the test. If a component does not operate when it should, check its electrical connection.

Check for open circuit or physical damage. If OK, refer to the product's wiring diagram and repeat the test with a voltmeter at the controller end of the harness.

Check with one voltmeter lead on the proper terminal and the other to ground. If no voltage is present during the suspect component's turn in the second test, the controller needs to be replaced. If there is voltage at the controller end but none at the component, the harness needs to be replaced.

Test	Seconds On	Air or Water Cooled Testing
1	30	Water inlet valve
2	10	Water Pump
3	10	Pump, Hot gas valve (and purge valve when used)
4	5	Hot gas valve, compressor
5	15	Compressor
6	5	None
7	10	Hot gas valve
8	5 or 10	Fan motor (10 secs)

### Notes:

- Remote model's fan motors cycle with compressors
- Check Valve Remote models are the CME456R, CME1056R, CME1356R, CME1656R and the CME2006R. Same results as shown, except for tests 5 and 8 (add harvest bypass valve - delete non-remote fan motor)
- Pump Down Remote models are the CME506R, CME656R and the CME806R. Same results as shown, except for tests 3 (no purge valve), 4 (add liquid line valve), 5 and 8 (add liquid line valve - delete fan motor)
- Eclipse models are the CME686, CME810, CME1386, CME1686 and the CME2086. Only tests 1, 2, and 4 are the same as shown. Substitute all refrigeration solenoid valves for hot gas valve in other tests.
- Water cooled and Eclipse models in test 8 have nothing operating.

## Water Level Sensor Test

<b>Column One:</b> Float Position	<b>Column Two:</b> Green Lights On	<b>Column Three:</b> Jumper Test
Over filled or dry sump (float all the way up or down), all of the slot is visible	Freeze, Harvest, Clean and Off	Unplugging sensor harness from #2 on controller.
Full sump	Harvest, Clean and Off	Jump pins one (bottom) and two
Mid position	Clean and Off	Jump pins one (bottom) and three, and pins one and two
Sump needs refill or end of freeze	Off	Jump pins one and three

### Water Level Sensor Test Results:

- If the lights change as listed in column two, the system has passed the test.
- If the test failed, perform the jumper test in column three. If that test results in the lights on as listed in column two, the controller is OK but the sensor or harness needs to be replaced. The harness can be checked the same way by unplugging the connection at the sensor and testing again.
- If the lights do not glow as indicated after the jumper test, the controller has failed and needs to be replaced.

# AutoSentry Control Board

## Indicator Light Reference

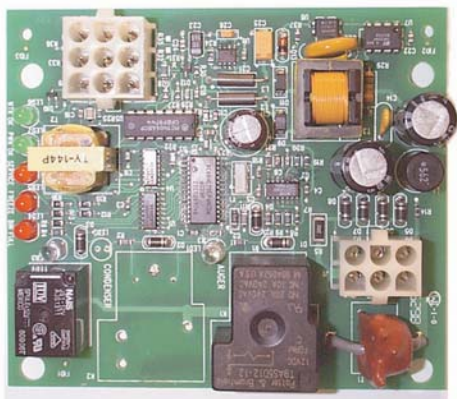

	Glowing	Blinking	Off
Water OK	Normal - Water sensor has continuity to chassis	When shutting off due to no water	No water or open circuit between sensor and ground
Power OK	Normal - Power to control board		No power to unit or pressure switch open
Service	Auger drive motor overloaded, needs manual reset	In restart mode	Normal
Freeze	Normal ice making mode	During two minute delay restart	Standby mode
Bin Full	Normal bin full mode	During shut down	Normal ice making mode

