



Preferred Service®

# Service Manual

This manual is to be used by qualified appliance technicians only. Viking does not assume any responsibility for property damage or personal injury for improper service procedures done by an unqualified person.

## Over the Range (OTR) Microwave

This Base Manual covers general and specific information including, but not limited to the following models:

**DMOR200SS**  
**RDMOR200SS**

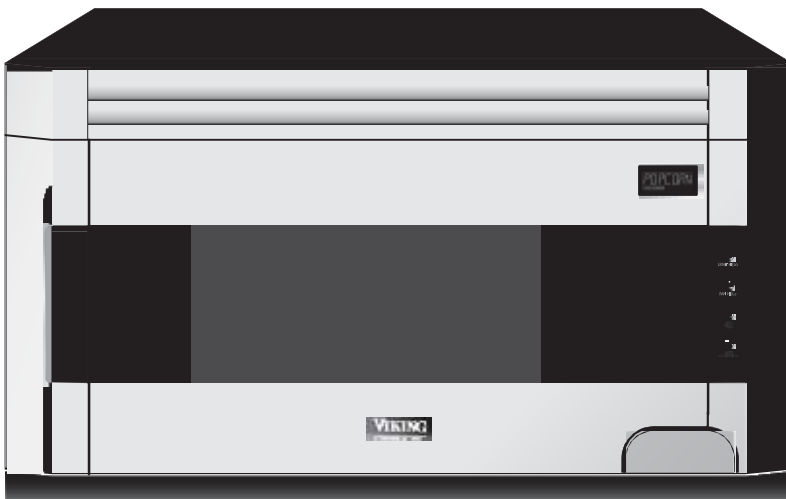

SMC-0021  
APR 2012

# Table of Contents



## Contents

Safety Information .....	3	RELAY TEST .....	30
Before Servicing .....	5	DEFROST CENTER TEST .....	31
When the testing is completed .....	5	FOIL PATTERN ON THE PRINTED WIRING BOARD TEST .....	31
After repairing .....	5	FOIL PATTERN ON THE PRINTED WIRING BOARD TEST (cont'd) .....	32
MICROWAVE MEASUREMENT PROCEDURE .....	6	NOISE FILTER TEST .....	32
A. Requirements: .....	6	NOISE FILTER TEST (cont'd) .....	33
B. Preparation for testing: .....	6	AH SENSOR TEST .....	33
C. Leakage test: .....	7	AH SENSOR TEST .....	34
GROUNDING INSTRUCTIONS .....	8	Checking Control Unit .....	35
Product Specifications .....	8	(1) Structure of Absolute Humidity Sensor .....	36
Electrical Requirements .....	9	(2) Operational Principle of Absolute Humidity Sensor .....	36
Oven Diagram .....	9	ABSOLUTE HUMIDITY SENSOR CIRCUIT .....	36
Display .....	10	(3) Detector Circuit of Absolute Humidity Sensor Circuit .....	36
OFF CONDITION .....	11	REMOVAL OF OVEN FROM WALL (Two persons recommended to remove the oven) .....	39
DESCRIPTION OF OPERATING SEQUENCE .....	11	HOOD EXHAUST LOUVER REMOVAL .....	39
COOKING CONDITION .....	12	OUTER CASE REMOVAL .....	39
POWER LEVEL P-0 TO P-90 COOKING .....	14	POWER TRANSFORMER REMOVAL .....	40
VENTILATION METHODS HOT AIR EXHAUST .....	15	HOOD FAN MOTOR REMOVAL .....	40
1. VERTICAL VENTING .....	15	MAGNETRON REMOVAL .....	40
2. HORIZONTAL VENTING .....	15	HOOD FAN THERMAL CUT-OUT REMOVAL .....	41
3. RE-CIRCULATION (INSIDE VENTING) .....	15	MAGNETRON REMOVAL (cont'd) .....	41
DOOR OPEN MECHANISM .....	16	HIGH VOLTAGE RECTIFIER AND HIGH VOLTAGE CAPACITOR REMOVAL .....	41
DOOR SENSING SWITCH, SECONDARY INTERLOCK SWITCH AND THIRD DOOR SWITCH .....	16	THERMAL CUT-OUT (CAVITY) REMOVAL .....	41
DESCRIPTION AND FUNCTION OF COMPONENTS .....	16	TEMPERATURE FUSE (MAGNETRON) REMOVAL .....	42
MONITOR SWITCH .....	16	COOLING FAN MOTOR REMOVAL .....	42
Functions: .....	16	INSTALLATION .....	43
TEMPERATURE FUSE (MG) .....	17	COOLING FAN MOTOR REMOVAL (cont'd) .....	43
THERMAL CUT-OUT (HOOD) .....	17	TURNTABLE MOTOR AND FOOD LAMP SOCKETS REMOVAL .....	44
THERMAL CUT-OUT (CAVITY) .....	17	OVEN LAMP AND LAMP SOCKET REMOVAL .....	44
TURNTABLE MOTOR .....	17	CONTROL PANEL ASSEMBLY, CONTROL UNIT AND KEY UNIT REMOVAL .....	45
COOLING FAN MOTOR .....	17	POSITIVE LOCK® CONNECTOR (NO-CASE TYPE) REMOVAL .....	45
HOOD FAN MOTOR .....	17	DOOR SENSING SWITCH, SECONDARY INTERLOCK SWITCH, THIRD DOOR AND MONITOR SWITCH REMOVAL .....	46
HOOD LAMP .....	18	Re-install .....	46
TROUBLESHOOTING GUIDE .....	19	DOOR SENSING SWITCH, SECONDARY INTERLOCK SWITCH, THIRD DOOR SWITCH AND MONITOR SWITCH ADJUSTMENT .....	47
MAGNETRON ASSEMBLY TEST .....	21	DOOR ASSEMBLY REMOVAL .....	48
POWER TRANSFORMER TEST .....	22	DOOR REPLACEMENT .....	48
HIGH VOLTAGE RECTIFIER TEST .....	22	After any servicing, make sure of the following :	48
HIGH VOLTAGE CAPACITOR TEST .....	23	DOOR DISASSEMBLY .....	49
CAVITY THERMAL CUT-OUT TEST .....	23	NOISE FILTER REMOVAL .....	50
MAGNETRON TEMPERATURE FUSE TEST .....	23	Pictorial Diagram .....	51
SECONDARY INTERLOCK SWITCH AND THIRD DOOR SWITCH TEST .....	24		
PRIMARY INTERLOCK SYSTEM TEST .....	24		
PRIMARY INTERLOCK SYSTEM TEST (cont'd) .....	25		
MONITOR SWITCH TEST .....	25		
BLOWN MONITOR FUSE TEST .....	26		
HOOD THERMAL CUT-OUT TEST .....	26		
HOOD FAN MOTOR TEST .....	27		
TOUCH CONTROL PANEL ASSEMBLY TEST .....	27		
TOUCH CONTROL PANEL ASSEMBLY TEST (cont'd) .....	28		
TOUCH CONTROL PANEL ASSEMBLY TEST (cont'd) .....	29		
KEY UNIT TEST .....	29		

## SAVE THESE INSTRUCTIONS

**REVIEW ALL SERVICE INFORMATION IN THE APPROPRIATE SERVICE MANUAL AND TECHNICAL SHEETS BEFORE BEGINNING REPAIRS.**

Pride and workmanship go into every product to provide our customers with quality products. It is possible, however, that during its lifetime, a product may require service. Products should be serviced only by a qualified service technician that is familiar with the safety procedures required in the repair and who is equipped with the proper tools, parts, testing instruments, and the appropriate service manual.

### Safety Information

We have provided many important safety messages in this manual and on the appliance. Always read and obey all safety messages. This is the safety alert symbol.



This symbol alerts you to hazards that can kill or hurt you and others. All safety messages will be preceded by the safety alert symbol and the word “DANGER”, “WARNING”, or “CAUTION”. These words mean:

DANGER

**IMMEDIATE HAZARDS WHICH WILL RESULT IN SEVERE PERSONAL INJURY OR DEATH.**

WARNING

Hazards or unsafe practices which COULD result in severe personal injury or death.

CAUTION

Hazards or unsafe practices which COULD result in minor personal injury or product or property damage.

All safety messages will identify the hazard, tell you how to reduce the chance of injury, and tell you what can happen if the instructions are not followed.

WARNING

To avoid risk of serious injury or death, repairs should not be attempted by unauthorized personnel.

CAUTION

VIKING will not be responsible for any injury or property damage from improper service procedures. If performing service on your own product, you must assume responsibility for any personal injury or property damage which may result.

Technical support for authorized servicers:

1-800-914-4799

Address your written correspondence to:

Viking Preferred Service  
1803 HWY 82 West  
Greenwood, MS 38930

## **WARNING**

In the interest of user-safety the oven should be restored to its original condition and only parts identical those specified should be used.

**WARNING TO SERVICE PERSONNEL:**  
Microwave ovens contain circuitry capable of producing very high voltage and current. Contact with the following parts may result in a severe, possibly fatal, electrical shock. (High Voltage Capacitor, High Voltage Power Transformer, Magnetron, High Voltage Rectifier Assembly, High Voltage Harness etc..)

## **DANGER**

PRECAUTIONS TO BE OBSERVED BEFORE AND DURING SERVICING TO AVOID POSSIBLE EXPOSURE TO EXCESSIVE MICROWAVE ENERGY

- (a) Do not operate or allow the oven to be operated with the door open.
- (b) Make the following safety checks on all ovens to be serviced before activating the magnetron or other microwave source, and make repairs as necessary: (1) interlock operation, (2) proper door closing, (3) seal and sealing surfaces (arcing, wear, and other damage), (4) damage to or loosening of hinges and latches, (5) evidence of dropping or abuse.
- (c) Before turning on microwave power for any service test or inspection within the microwave generating compartments, check the magnetron, wave guide or transmission line, and cavity for proper alignment, integrity, and connections.
- (d) Any defective or misadjusted components in the interlock, monitor, door seal, and microwave generation and transmission systems shall be repaired, replaced, or adjusted by procedures

described in this manual before the oven is released to the owner.

- (e) A microwave leakage check to verify compliance with the Federal Performance Standard should be performed on each oven prior to release to the owner.

### BEFORE SERVICING

Before servicing an operative unit, perform a microwave emission check as per the Microwave Measurement Procedure outlined in this service manual.

If microwave emissions level is in excess of the specified limit, contact Viking Service immediately @ 1- 888-845-4641.

If the unit operates with the door open, service person should (1) tell the user not to operate the oven and (2) contact VIKING, plus the Department Of Health, Canada and/or the Food and Drug Administration's Center for Devices and Radiological Health immediately.

Service personnel should inform VIKING of any certified unit found with emissions in excess of 4mW/ cm<sup>2</sup>. The owner of the unit should be instructed not to use the unit until the oven has been brought into compliance.

## DANGER

### WARNING TO SERVICE PERSONNEL

Microwave ovens contain circuitry capable of producing very high voltage and current, contact with following parts may result in a severe, possibly fatal, electrical shock.

(Example)

High Voltage Capacitor, High Voltage Power Transformer, Magnetron, High Voltage Rectifier Assembly, High Voltage Harness etc..

Read the Service Manual carefully and follow all instructions.

### Before Servicing

1. Disconnect the power supply cord, and then remove outer case.
2. Open the door and block it open.
3. Discharge high voltage capacitor.



## WARNING

RISK OF ELECTRIC SHOCK..

DISCHARGE THE HIGH-VOLTAGE CAPACITOR BEFORE SERVICING.

The high-voltage capacitor remains charged about 60 seconds after the oven has been switched off. Wait for 60 seconds and then short-circuit the connection of the high-voltage capacitor (that is the connecting lead of the high-voltage rectifier) against the chassis with the use of an insulated screwdriver.

Whenever troubleshooting is performed the power supply must be disconnected. It may, in some cases, be necessary to connect the power supply after the outer case has been removed, in this event,

1. Disconnect the power supply cord, and then remove outer case.
2. Open the door and block it open.
3. Discharge high voltage capacitor.
4. Disconnect the leads to the primary of the power transformer.

5. Ensure that these leads remain isolated from other components and oven chassis by using insulation tape.
6. After that procedure, reconnect the power supply cord.

## DANGER

Don't Touch ! Danger High Voltage

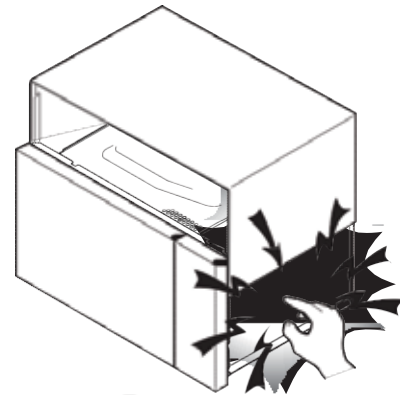

### When the testing is completed

1. Disconnect the power supply cord, and then remove outer case.
2. Open the door and block it open.
3. Discharge high voltage capacitor.
4. Reconnect the leads to the primary of the power transformer.
5. Reinstall the outer case (cabinet)
6. Reconnect the power supply cord after the outer case is installed.
7. Run the oven and check all functions.

### After repairing

1. Reconnect all leads removed from components during testing.
2. Reinstall the outer case (cabinet).
3. Reconnect the power supply cord after the outer case is installed.
4. Run the oven and check all functions.

Microwave ovens should not be run empty. To test for the presence of microwave energy within a cavity, place a cup of cold water on the oven turntable, close the door and set the power to HIGH and set the microwave timer for two (2) minutes. When the two minutes has elapsed (timer at zero) carefully check that the water is now hot. If the water remains cold carry out Before Servicing procedure and re-examine the connections to the component being tested.

When all service work is completed and the oven is fully assembled, the microwave power output should be checked and microwave leakage test should be carried out.

## MICROWAVE MEASUREMENT PROCEDURE

### A. Requirements:

1. Microwave leakage limit (Power density limit): The power density of microwave radiation emitted by a microwave oven should not exceed  $1\text{mW}/\text{cm}^2$  at any point 5cm or more from the external surface of the oven, measured prior to acquisition by a purchaser, and thereafter (through the useful life of the oven),  $5\text{mW}/\text{cm}^2$  at any point 5cm or more from the external surface of the oven.
2. Safety interlock switches: Primary interlock relay switch shall prevent microwave radiation emission in excess of the requirement as above mentioned. Secondary interlock relay and door sensing switch shall prevent microwave radiation emission in excess of  $5\text{mW}/\text{cm}^2$  at any point 5cm or more from the external surface of the oven.

### B. Preparation for testing:

Before beginning the actual measurement of leakage, proceed as follows:

1. Make sure that the actual instrument is operating normally as specified in its instruction booklet.

Important:

USA Survey instruments that comply with the requirement for instrumentation as prescribed by the Federal Performance Standard for microwave ovens, 21 CFR 1030.10(c)(3)(i), must be used for testing.

Canadian Survey instruments that comply with the requirement for instrumentation as prescribed by CSA and NHW performance standard for microwave ovens must be used for testing recommended instruments are , NARDA 8100 and NARDA 8200.

2. Place the load of  $275\pm 15\text{ml}$  (9.8 oz) of tap water initially at  $20\pm 5\text{C}$  (68OF) in the center of the oven cavity. The water container shall be a low form of 600 ml (20 oz) beaker with an inside diameter of approx. 8.5 cm (3-1/2 in.) and made of an electrically non conductive material such as glass or plastic. The placing of this standard load in the oven is important not only to protect the oven, but also to insure that any leakage is measured accurately.
3. Set the cooking control on Full Power Cooking Mode.
4. Close the drawer and select a cook cycle of several minutes. If the water begins to boil before the survey is completed, replace it with 275 ml of cool water.

**C. Leakage test:**

Closed-drawer leakage test (microwave measurement):

1. Grasp the probe of the survey instrument and hold it perpendicular to the gap between the drawer and the body of the oven.
2. Move the probe slowly, not faster than 1 in./sec. (2.5 cm/sec.) along the gap, watching for the maximum indication on the meter.
3. Check for leakage at the drawer screen, sheet metal seams and other accessible positions where the continuity of the metal has been breached (eg., around the switches, indicator, and vents). While testing for leakage around the drawer, pull the drawer away from the front of the oven as far as is permitted by the closed latch assembly.
4. Measure carefully at the point of highest leakage and make sure that the highest leakage is no greater than 4mW/cm<sup>2</sup>, and that the primary interlock switch/secondary interlock relay does turn the oven OFF before any door movement.

NOTE: After servicing, record data on service invoice and microwave leakage report.



## Product Specifications

ITEM	DESCRIPTION
Power Requirements	120 Volts / 13 Amperes 60 Hertz Single phase, 3 wire grounded
Power Output	950 watts (IEC TEST PROCEDURE) Operating frequency of 2450MHz
Case Dimensions	Width 29-15/16" Height 16- 1/4" Depth 15- 9/16"
Cooking Cavity Dimensions 1.5 Cubic Feet	Width 17-1/2" Height 9-7/8" Depth 14-15/16"
Hood lamp	2 bulbs, 20W x 2, Incandescent light bulbs
Hood fan	Approx. 300 C.F.M.
Control Complement	Touch Control System Clock ( 1:00 - 12:59 ) Timer (0 - 99 min. 99 seconds) Microwave Power for Variable Cooking Repetition Rate; P-HI ..... Full power throughout the cooking time P-90 ..... approx. 90% of Full Power P-80 ..... approx. 80% of Full Power P-70 ..... approx. 70% of Full Power P-60 ..... approx. 60% of Full Power P-50 ..... approx. 50% of Full Power P-40 ..... approx. 40% of Full Power P-30 ..... approx. 30% of Full Power P-20 ..... approx. 20% of Full Power P-10 ..... approx. 10% of Full Power P-0 ..... No power throughout the cooking time  KEEP WARM PLUS pad, POPCORN pad, HOT WATER pad REHEAT pad, DEFROST pads, Number selection pads, REHEAT pads, POWER LEVEL pad, TIMER / CLOCK pad, FRESH VEGETABLES pad, LIGHT HI / LO button, FAN HI / LO button, SENSOR COOK pads, STOP/CLEAR button, START/ ADD-A-MINUTE button, HELP pad.
Oven Cavity Light	20W x 1 Incandescent light bulb
Safety Standard	CUL Listed            FCC Authorized DHHS Rules, CFR, Title 21, Chapter 1, Sub chapter J and Canadian Standards Association. Health CANADA.
Weight	Approx. 55 lbs.

### GROUNDING INSTRUCTIONS

This oven is equipped with a three prong grounding plug. It must be plugged into a wall receptacle that is properly installed and grounded in accordance with the National Electrical Code and local codes and ordinances. In the event of an electrical short circuit, grounding reduces the risk of electric shock by providing an escape wire for the electric current.

**WARNING:**            *Improper use of the grounding plug can result in a risk of electric shock.*



## Electrical Requirements

The oven is equipped with a 3-prong grounding plug. **DO NOT UNDER ANY CIRCUMSTANCES CUT OR REMOVE THE GROUNDING PIN FROM THE PLUG.**

The power supply cord and plug must be connected to a separate 120 Volt AC, 60 Hz, 15 Amp. or more dedicated line, using a grounded receptacle. The receptacle should be located inside the cabinet directly above the Microwave Oven/Hood system mounting location.

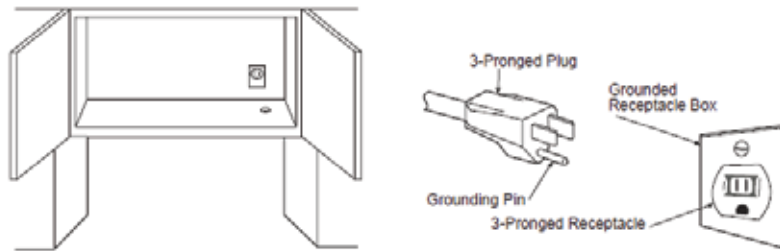

## Oven Diagram

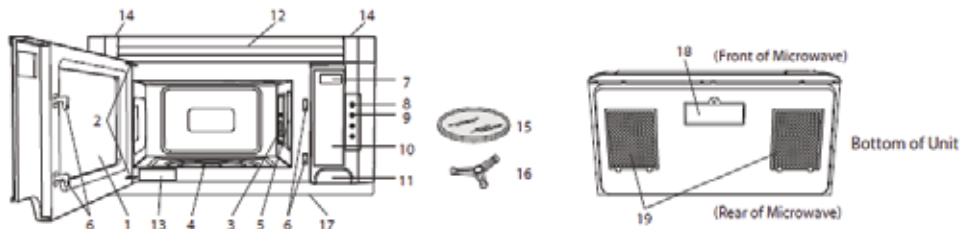

- |  |  |
|--|--|
| <p>1 Oven door with see-through window</p> <p>2 Door hinges</p> <p>3 Waveguide cover<br/>DO NOT REMOVE.</p> <p>4 Turntable motor shaft</p> <p>5 Oven light - on during operation and when the door is open.</p> <p>6 Safety door latches - door must be securely closed for the oven to operate.</p> <p>7 Cook and time display</p> <p>8 LIGHT Hi/Lo pad - controls interior light<br/>Press the LIGHT Hi/Lo pad once for Hi. Press again for Lo. Press a third time to turn the light off.</p> <p>9 FAN Hi/Lo pad - controls fan<br/>Press the FAN Hi/Lo pad once for Hi. Press again for Lo. Press a third time to turn the fan off.</p> <p>10 Control panel</p> <p>11 One touch DOOR OPEN<br/>Push to open door</p> | <p>12 Louver</p> <p>13 Nameplate</p> <p>14 Louver screws - remove screws to replace charcoal filter.</p> <p>15 Removable turntable - rotates clockwise or counterclockwise<br/>Only remove for cleaning</p> <p>16 Removable turntable support<br/>1. Carefully place the turntable support in the motor shaft in the center of the oven floor.<br/>2. Place the turntable on the turntable support securely.</p> <p>17 Heat deflector</p> <p>18 Light cover</p> <p>19 Grease filters</p> |
|--|--|

## **WARNING**

To avoid risk of electrical shock, personal injury, or death, disconnect electrical power source to unit, unless test procedures require power to be connected. Discharge capacitor through a resistor before attempting to service. Ensure all ground wires are connected before certifying unit as repaired and/or operational.

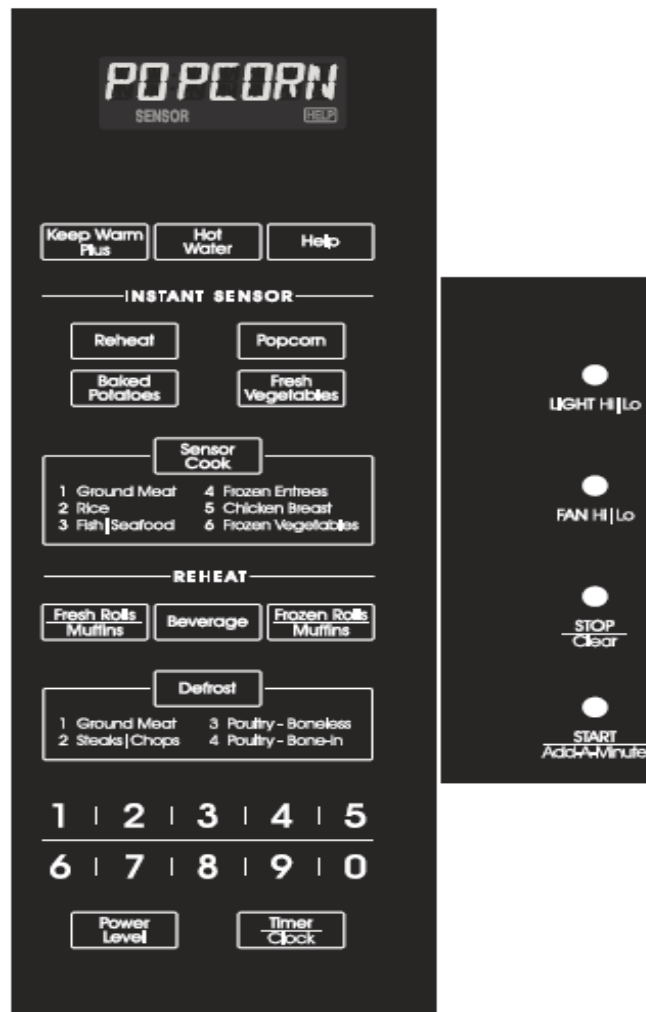

NOTE: Some one-touch cooking features such as "ADD-A-MINUTE" are disabled after three minutes when the oven is not used. These features are automatically enabled when the door is opened and closed or STOP/CLEAR button is pressed.

**⚠ WARNING**

To avoid risk of electrical shock, personal injury, or death, disconnect electrical power source to unit, unless test procedures require power to be connected. Discharge capacitor through a resistor before attempting to service. Ensure all ground wires are connected before certifying unit as repaired and/or operational.

**DESCRIPTION OF OPERATING SEQUENCE**

The following is a description of component functions during oven operation.

**OFF CONDITION**

Closing the door activates the door sensing switch and primary interlock switch. (In this condition, the monitor switch contacts are opened.) When oven is plugged in, 120 volts A.C. is supplied to the control unit. (Figure O-1).

1. The display will show flashing "Welcome Press Clear and Press Clock". To set any program or set the clock, you must first touch the STOP/CLEAR button. The display will clear, and " : " will appear .

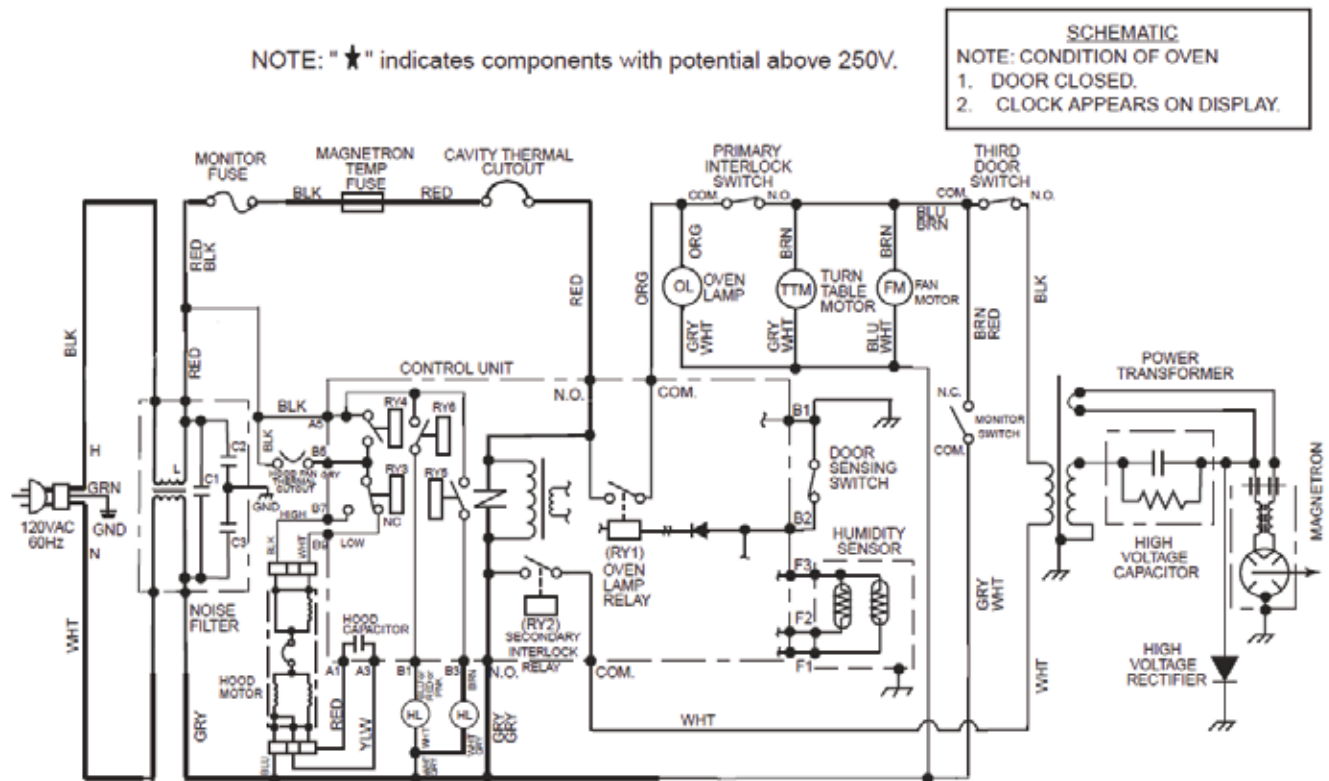

Figure O-1. Oven Schematic-Off Condition

## ⚠ WARNING

To avoid risk of electrical shock, personal injury, or death, disconnect electrical power source to unit, unless test procedures require power to be connected. Discharge capacitor through a resistor before attempting to service. Ensure all ground wires are connected before certifying unit as repaired and/or operational.

### COOKING CONDITION

Program desired cooking time touching the NUMBER pads. When the START button is touched, the following operations occur:

1. The contacts of relays are closed and components connected to the relays are turned on as follows. (For details, refer to Figure O-2)

RELAY	CONNECTED COMPONENTS
RY1	Oven lamp / Fan motor / Turntable motor
RY2	Power transformer
RY3, RY4	Hood fan motor
RY5, RY6	Hood lamp

2. 120 volts A.C. is supplied to the primary winding of the power transformer and is converted to about 3.3 volts A.C. output on the filament winding, and approximately 2000 volts A.C. on the high voltage winding.
3. The filament winding voltage heats the magnetron filament and the H.V. winding voltage is sent to a voltage doubler circuit.

NOTE: ★ indicates components with potential above 250V.

**SCHEMATIC**  
NOTE: CONDITION OF OVEN  
1. DOOR CLOSED.  
2. COOKING TIME PROGRAMMED.  
3. VARIABLE COOKING CONTROL "HIGH".

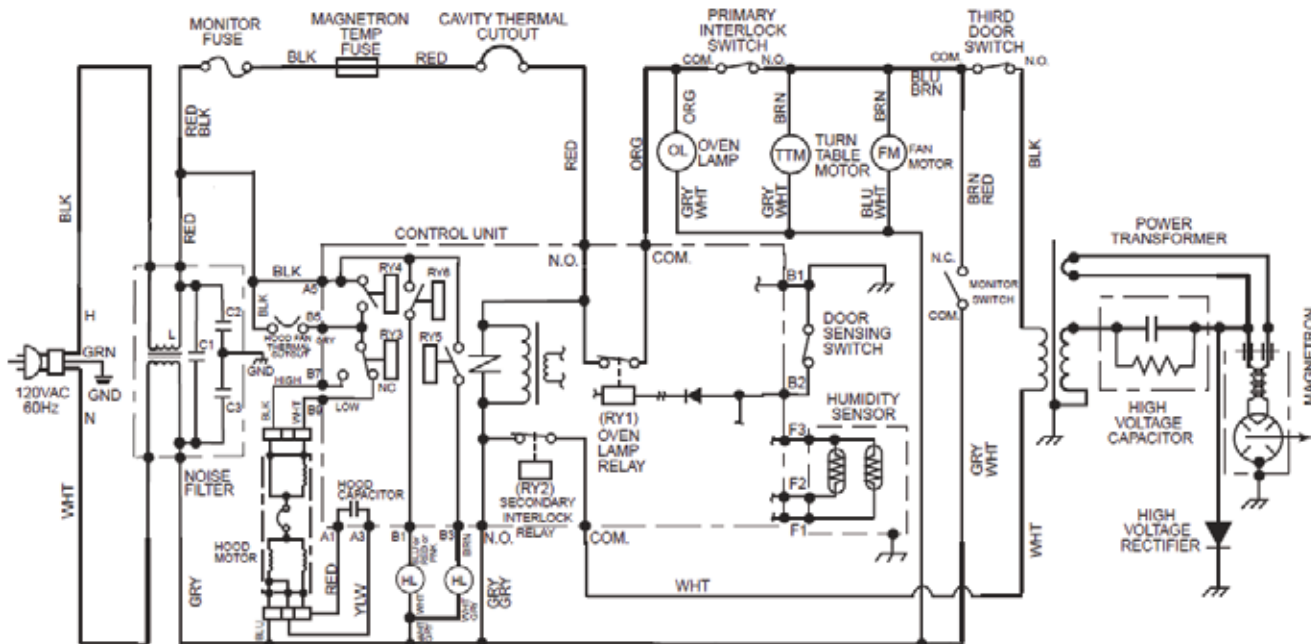

Figure O-2. Oven Schematic-Cooking Condition

**WARNING**

To avoid risk of electrical shock, personal injury, or death, disconnect electrical power source to unit, unless test procedures require power to be connected. Discharge capacitor through a resistor before attempting to service. Ensure all ground wires are connected before certifying unit as repaired and/or operational.

4. The microwave energy produced by the magnetron is channelled through the wave guide into the cavity feed- box, and then into the cavity where the food is placed to be cooked.
  5. Upon completion of the cooking time, the power transformer, oven lamp, etc. are turned off, and the generation of microwave energy is stopped. The oven will revert to the OFF condition.
  6. When the door is opened during a cook cycle, monitor switch, door sensing switch, secondary interlock switch, third door switch and primary interlock relay are activated with the following results. The circuits to the stirrer motor, the cooling fan motor, the turntable motor, and the high voltage components are de- energized, and the digital read-out displays the time still remaining in the cook cycle when the door was opened.
  7. The monitor switch is electrically monitoring the operation of the secondary interlock switch, third door switch and door sensing switch is mechanically associated with the door so that it will function in the following sequence.
    - (1) When the door opens from a closed position, the primary interlock relay, door sensing switch, third door switch and secondary interlock switch open their contacts, and then the monitor switch contacts close.
    - (2) When the door is closed from the open position, the monitor switch contacts first open, and then the contacts of the secondary interlock switch, third door switch close.
- If the secondary interlock switch and third door switch fail with their contacts closed when the door is opened, the closing of the monitor switch contacts will form a short circuit through the monitor fuse, secondary interlock switch and third door switch, causing the monitor fuse to blow.

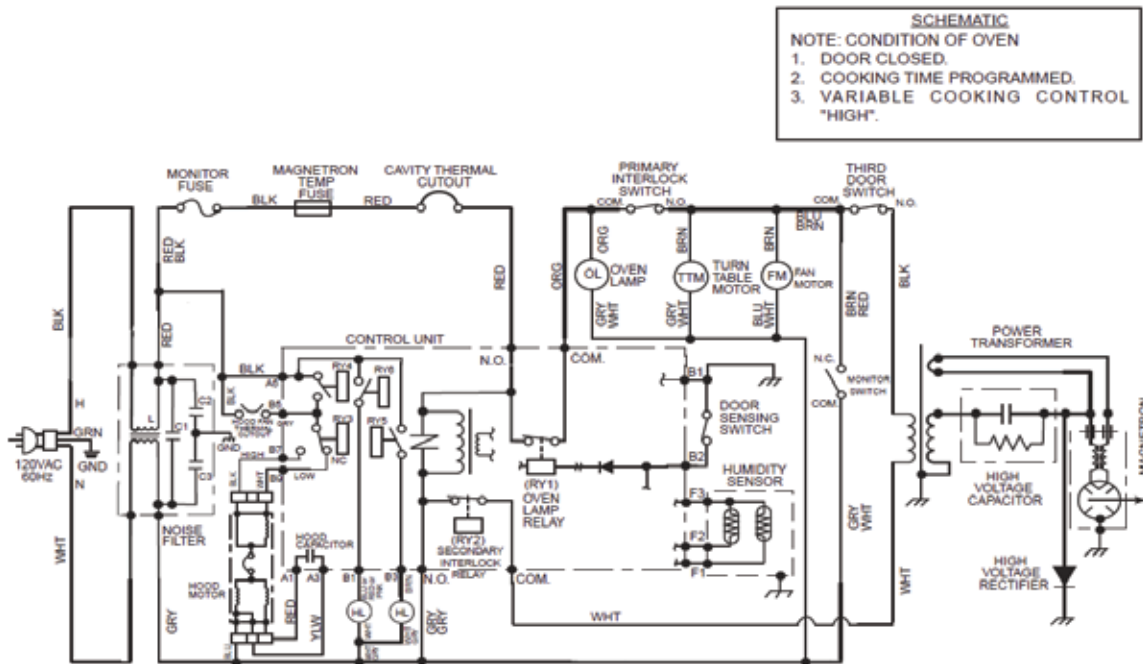

Figure O-2. Oven Schematic-Cooking Condition



## WARNING

To avoid risk of electrical shock, personal injury, or death, disconnect electrical power source to unit, unless test procedures require power to be connected. Discharge capacitor through a resistor before attempting to service. Ensure all ground wires are connected before certifying unit as repaired and/or operational.

### POWER LEVEL P-0 TO P-90 COOKING

When Variable Cooking Power is programmed, the 120 volts A.C. is supplied to the power transformer intermittently through the contacts of relay (RY2) which is operated by the control unit within an interval second time base. Microwave power operation is as follows:

VARI-MODE	ON TIME	OFF TIME
Power 10(P-HI) (100% power)	32 sec.	0 sec.
Power 9(P-90) (approx. 90% power)	30 sec.	2 sec.
Power 8(P-80) (approx. 80% power)	26 sec.	6 sec.
Power 7(P-70) (approx. 70% power)	24 sec.	8 sec.
Power 6(P-60) (approx. 60% power)	22 sec.	10 sec.
Power 5(P-50) (approx. 50% power)	18 sec.	14 sec.
Power 4(P-40) (approx. 40% power)	16 sec.	16 sec.
Power 3(P-30) (approx. 30% power)	12 sec.	20 sec.
Power 2(P-20) (approx. 20% power)	8 sec.	24 sec.
Power 1(P-10) (approx. 10% power)	6 sec.	26 sec.
Power 0(P-0) (0% power)	0 sec.	32 sec.

Note: The ON/OFF time ratio does not correspond with the percentage of microwave power, because approx. 3 seconds are needed for heating of the magnetron filamen

## ! WARNING

To avoid risk of electrical shock, personal injury, or death, disconnect electrical power source to unit, unless test procedures require power to be connected. Discharge capacitor through a resistor before attempting to service. Ensure all ground wires are connected before certifying unit as repaired and/or operational.

### VENTILATION METHODS HOT AIR EXHAUST

#### 1. VERTICAL VENTING

For this venting method, hot air rising from the conventional range below is drawn in by the hood fan motor through the grease filters at the right and left sides of the base cover, up through the right and left sides of the oven cavity, then discharged vertically at rear center top of the oven, into the customer's vent system.

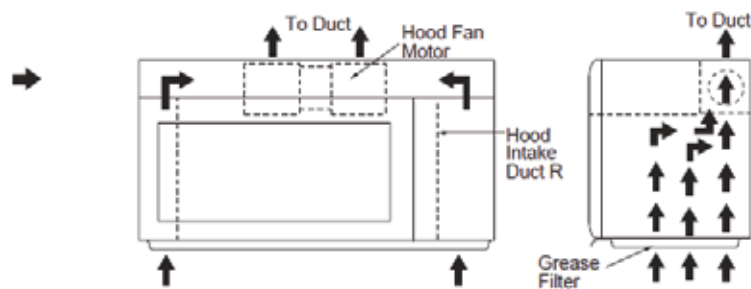

#### 2. HORIZONTAL VENTING

The air handling is the same as VERTICAL VENTING except that the final air discharge is directed horizontally out from the top rear of the oven into the customer's vent system.

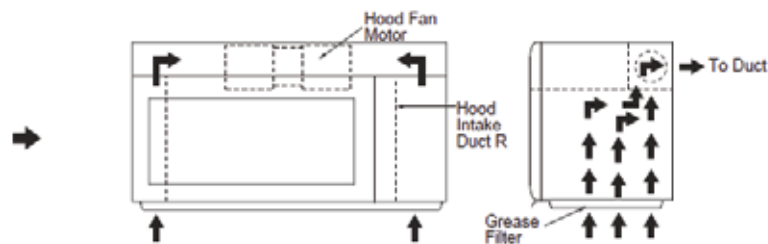

#### 3. RE-CIRCULATION (INSIDE VENTING)

The air handling is the same as VERTICAL VENTING except that the final air discharge is directed horizontally through the upper front of the oven into the kitchen. IN this case, the accessory charcoal filter RK-240 must be provided to filter the air before it leaves the oven.

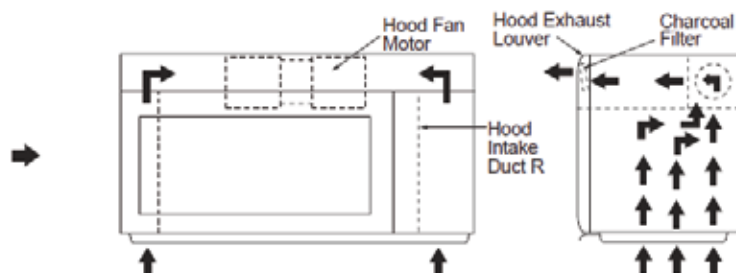



## ⚠ WARNING

To avoid risk of electrical shock, personal injury, or death, disconnect electrical power source to unit, unless test procedures require power to be connected. Discharge capacitor through a resistor before attempting to service. Ensure all ground wires are connected before certifying unit as repaired and/or operational.

### DESCRIPTION AND FUNCTION OF COMPONENTS

#### DOOR OPEN MECHANISM

The door is opened by pulling the door handle, refer to the Figure D-1.

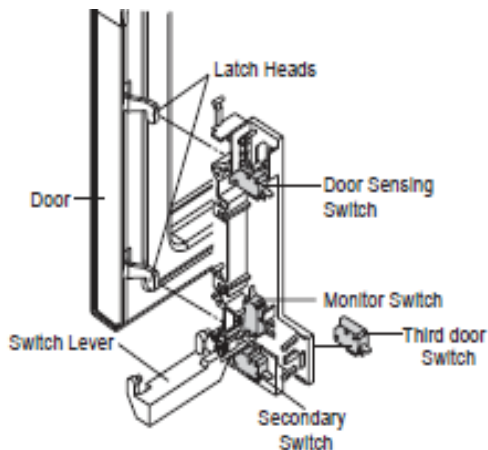

Figure D-1. Door Open Mechanism

#### DOOR SENSING SWITCH, SECONDARY INTER- LOCK SWITCHES AND THIRD DOOR SWITCH

The secondary interlock switch is mounted in the lower position of the latch hook, the door sensing switch in the primary interlock system is mounted in the upper position of the latch hook and the third door switch is mounted on upper position of the latch hook. They are activated by the latch heads on the door. When the door is opened, the switches interrupt the circuit to all components. A cook cycle cannot take place until the door is firmly closed thereby activating both interlock switches. The primary interlock system consists of the door sensing switch and primary interlock relay located on the control circuit board.

#### MONITOR SWITCH

The monitor switch is activated (the contacts opened) by the latch head on the door while the door is closed. The switch is intended to render the oven inoperative by means of blowing the monitor fuse when the contacts of the primary interlock relay (RY2) and secondary interlock switch and third door switch fail to open when the door is opened.

#### Functions:

1. When the door is opened, the monitor switch contact close (to the ON condition) due to their being normally closed. At this time the primary interlock relay (RY2), secondary interlock switch and third door switch are in the OFF condition (contacts open) due to their being normally open contact switches. And the contacts of relay (RY1) are in the ON condition (contacts close).
2. As the door goes to a closed position, the monitor switch contacts are first opened and then the door sensing switch and the secondary interlock switch and third door switch contacts close. (On opening the door, each of these switches operate inversely.)
3. If the door is opened, and the primary interlock relay (RY2) and secondary interlock switch and third door contacts fail to open, the monitor fuse blows simultaneously with closing of the monitor switch contacts.

**WARNING**

To avoid risk of electrical shock, personal injury, or death, disconnect electrical power source to unit, unless test procedures require power to be connected. Discharge capacitor through a resistor before attempting to service. Ensure all ground wires are connected before certifying unit as repaired and/or operational.

**CAUTION**

BEFORE REPLACING A BLOWN MONITOR FUSE TEST THE DOOR SENSING SWITCH, PRIMARY INTERLOCK RELAY (RY2), SEC- ONDARY INTERLOCK SWITCH, THIRD DOOR SWITCH AND MONITOR SWITCH FOR PROPER OPERATION. (REFER TO CHAPTER "TEST PROCEDURE").

***NOTE: MONITOR FUSE, MONITOR SWITCH AND SECONDARY INTERLOCK SWITCH ARE REPLACED AS AN ASSEMBLY***

**TEMPERATURE FUSE (MG)**

The temperature fuse located near the waveguide is designed to prevent damage to the magnetron if an over heated condition develops in the tube due to cooling fan failure, obstructed air guide, dirty or blocked air intake, etc. Under normal operation, the temperature fuse remains closed. However, the temperature fuse will open at 302OF (150OC) causing the oven to shut down.

**THERMAL CUT-OUT (HOOD )**

This thermal cut-out located on the right base plate. It is designed to automatically turn on the hood fan motor whenever the hot air rising from the conventional range below causes the temperature at the thermal cut-out to rise to 140OF (60OC) or higher, thus removing this hot air from around microwave oven. When the temperature around the thermal cut-out drops to 113OF (45OC) or lower, the thermal cut-out shuts off the hood fan motor.

**THERMAL CUT-OUT (CAVITY )**

This thermal cut-out is located on the top of the oven cavity. It is designed to prevent damage to the oven unit if the food in the oven catches fire due to overheating produced by improper setting of cooking time or failure of control unit. Under normal operation, the thermal cut-out remains closed. However, the thermal cut-out will open at 293OF (145OC) causing the oven to shut down.

**TURNTABLE MOTOR**

The turntable motor rotates the turntable located on the bottom of the oven cavity, so that the foods on the turntable cook evenly during cooking. Turntable will turn in either direction. The turntable motor can be turned off by touching TURNTABLE ON/OFF pad.

**COOLING FAN MOTOR**

The cooling fan motor drives a blade which draws external cool air. This cool air is directed through the air vanes surrounding the magnetron and cools the magnetron. This air is channelled through the oven cavity to remove steam and vapors given off from the heating foods. It is then exhausted through the exhausting air vents at the oven cavity.

**HOOD FAN MOTOR**

The hood fan motor is a two-speed, single-phase, double pole induction type, requiring a hood fan capacitor. It is located outside the upper rear part of the oven cavity, is to remove, from around the oven, hot air rising from the conventional electric or gas range over which it is installed. This air is



## WARNING

To avoid risk of electrical shock, personal injury, or death, disconnect electrical power source to unit, unless test procedures require power to be connected. Discharge capacitor through a resistor before attempting to service. Ensure all ground wires are connected before certifying unit as repaired and/or operational.

then expelled either vertically or horizontally through the customer supplied duct system, or discharged back into the kitchen.

### HOOD LAMP

The hood lamps are mounted at the hood lamp angle on the base cover. The hood lamps can be turned off and on by touching the LIGHT HI/ LO button. And also the brightness can be varied to high or low by touching the LIGHT HI/ LO button.

**WARNING**

To avoid risk of electrical shock, personal injury, or death, disconnect electrical power source to unit, unless test procedures require power to be connected. Discharge capacitor through a resistor before attempting to service. Ensure all ground wires are connected before certifying unit as repaired and/or operational.

**TROUBLESHOOTING GUIDE**

***Never touch any part in the circuit with your hand or an uninsulated tool while the power supply is connected.***

When troubleshooting the microwave oven, it is helpful to follow the Sequence of Operation in performing the checks. Many of the possible causes of trouble will require that a specific test be performed. These tests are given a procedure letter which will be found in the "Test Procedure" section.

**IMPORTANT:** If the oven becomes inoperative because of a blown monitor fuse, check the monitor switch, relay (RY1) primary interlock relay (RY2), door sensing switch, secondary interlock switch and third door switch before replacing the monitor fuse. If monitor fuse is replaced, the monitor switch and secondary interlock switch must also be replaced. Use part FFS-BA018/KiT as an assembly.

**IMPORTANT:** Whenever troubleshooting is performed with the power supply cord disconnected. It may in, some cases, be necessary to connect the power supply cord after the outer case has been removed, in this event,

1. Disconnect the power supply cord, and then remove outer case.
2. Open the door and block it open.
3. Discharge high voltage capacitor.
4. Disconnect the leads to the primary of the power transformer.
5. Ensure that the leads remain isolated from other components and oven chassis by using insulation tape.
6. After that procedure, reconnect the power supply cord.

**When the testing is completed**

1. Disconnect the power supply cord, and then remove outer case.
2. Open the door and block it open.
3. Discharge high voltage capacitor.
4. Reconnect the leads to the primary of the power transformer.
5. Reinstall the outer case (cabinet).
6. Reconnect the power supply cord after the outer case is installed.
7. Run the oven and check all functions.



**WARNING**

To avoid risk of electrical shock, personal injury, or death, disconnect electrical power source to unit, unless test procedures require power to be connected. Discharge capacitor through a resistor before attempting to service. Ensure all ground wires are connected before certifying unit as repaired and/or operational.

PROCEDURE  
LETTER

COMPONENT TEST

A

**MAGNETRON ASSEMBLY TEST**

1. Disconnect the power supply cord, and then remove outer case.
2. Open the door and block it open.
3. Discharge high voltage capacitor.
4. To test for an open filament, isolate the magnetron from the high voltage circuit. A continuity check across the magnetron filament leads should indicate less than 1 ohm.
5. To test for a shorted magnetron, connect the ohmmeter leads between the magnetron filament leads and chassis ground. This test should indicate an infinite resistance. If there is little or no resistance the magnetron is grounded and must be replaced.
6. Reconnect all leads removed from components during testing.
7. Reinstall the outer case (cabinet).
8. Reconnect the power supply cord after the outer case is installed.
9. Run the oven and check all functions.

**MICROWAVE OUTPUT POWER****DANGER**

***HIGH VOLTAGES ARE PRESENT DURING THE COOK CYCLE, SO EXTREME CAUTION SHOULD BE OBSERVED.***

The following test procedure should be carried out with the microwave oven in a fully assembled condition (outer case fitted).

Power output of the magnetron can be measured by performing a water temperature rise test. This test should only be used if above tests do not indicate a faulty magnetron and there is no defect in the following components or wiring: silicon rectifier, high voltage capacitor and power transformer. This test will require a 16 ounce (453cc) measuring cup and an accurate mercury thermometer or thermocouple type temperature tester. For accurate results, the following procedure must be followed carefully:

1. Fill the measuring cup with 16 oz. (453cc) of tap water and measure the temperature of the water with a thermometer or thermocouple temperature tester. Stir the thermometer or thermocouple through the water until the temperature stabilizes. Record the temperature of the water.
2. Place the cup of water in the oven. Operate oven at POWER 10(HIGH) selecting more than 60 seconds cook time. Allow the water to heat for 60 seconds, measuring with a stop watch, second hand of a watch or the digital read-out countdown.
3. Remove the cup from the oven and again measure the temperature, making sure to stir the thermometer or thermocouple through the water until the maximum temperature is recorded.
4. Subtract the cold water temperature from the hot water temperature. The normal result should be 29.2 to 54.2°F (16.2 to 30.1°C) rise in temperature. If the water temperatures are accurately measured and tested for the required time period the test results will





## WARNING

To avoid risk of electrical shock, personal injury, or death, disconnect electrical power source to unit, unless test procedures require power to be connected. Discharge capacitor through a resistor before attempting to service. Ensure all ground wires are connected before certifying unit as repaired and/or operational.

PROCEDURE  
LETTER

COMPONENT TEST

- A indicate if the magnetron tube has low power output (low rise in water temperature) which would extend cooking time or high power output (high rise in water temperature) which would reduce cooking time. Because cooking time can be adjusted to compensate for power output, the magnetron tube assembly should be replaced only if the water temperature rise test indicates a power output well beyond the normal limits. The test is only accurate if the power supply line voltage is 120 volts and the oven cavity is clean.

B **POWER TRANSFORMER TEST**

1. Disconnect the power supply cord, and then remove outer case.
2. Open the door and block it open.
3. Discharge high voltage capacitor.
4. Disconnect the primary input terminals and measure the resistance of the transformer with an ohmmeter. Check for continuity of the coils with an ohmmeter. On the R x 1 scale, the resistance of the primary coil should be less than 1 ohm and the resistance of the high voltage coil should be approximately 160 ohms (+ or - 5%); the resistance of the filament coil should be less than 1 ohm.
5. Reconnect all leads removed from components during testing.
6. Reinstall the outer case (cabinet).
7. Reconnect the power supply cord after the outer case is installed.
8. Run the oven and check all functions.



## DANGER

**(HIGH VOLTAGES ARE PRESENT AT THE HIGH VOLTAGE TERMINAL, SO DO NOT ATTEMPT TO MEASURE THE FILAMENT AND HIGH VOLTAGE.)**

C **HIGH VOLTAGE RECTIFIER TEST**

1. Disconnect the power supply cord, and then remove outer case.
2. Open the door and block it open.
3. Discharge high voltage capacitor.
4. Isolate the rectifier from the circuit. Using the highest ohm scale of the meter, read the resistance across the terminals and observe, reverse the leads to the rectifier terminals and observe meter reading. If a short is indicated in both directions, or if an infinite resistance is read in both directions, the rectifier is probably defective and should be replaced.
5. Reconnect all leads removed from components during testing.
6. Reinstall the outer case (cabinet).
7. Reconnect the power supply cord after the outer case is installed.
8. Run the oven and check all functions.

**NOTE: Be sure to use an ohmmeter that will supply a forward bias voltage of more than 6.3 volts.**



**WARNING**

To avoid risk of electrical shock, personal injury, or death, disconnect electrical power source to unit, unless test procedures require power to be connected. Discharge capacitor through a resistor before attempting to service. Ensure all ground wires are connected before certifying unit as repaired and/or operational.

---

**PROCEDURE  
LETTER**
**COMPONENT TEST**

---

**D HIGH VOLTAGE CAPACITOR TEST**

1. Disconnect the power supply cord, and then remove outer case.
2. Open the door and block it open.
3. Discharge high voltage capacitor.
4. If the capacitor is open, no high voltage will be available to the magnetron. Disconnect input leads and check for short or open between the terminals using an ohmmeter. Checking with a high ohm scale, if the high voltage capacitor is normal, the meter will indicate continuity for a short time and should indicate an open circuit once the capacitor is charged. If the above is not the case, check the capacitor with an ohmmeter to see if it is shorted between either of the terminals and case. If it is shorted, replace the capacitor.
5. Reconnect all leads removed from components during testing.
6. Reinstall the outer case (cabinet).
7. Reconnect the power supply cord after the outer case is installed.
8. Run the oven and check all functions.

**E CAVITY THERMAL CUT-OUT TEST**

1. Disconnect the power supply cord, and then remove outer case.
2. Open the door and block it open.
3. Discharge high voltage capacitor.
4. A continuity check across the thermal cut-out terminals should indicate a closed circuit unless the temperature of the thermal cut-out reaches approximately 293°F(145°C). An open thermal cut-out indicates overheating of the oven, exchange the oven thermal cut-out and check inside of oven cavity and for improper setting of cooking time or operation of control unit. Check for restricted air flow through the vent holes of the oven cavity, especially the cooling fan and air guide.
5. Reconnect all leads removed from components during testing.
6. Reinstall the outer case (cabinet).
7. Reconnect the power supply cord after the outer case is installed.
8. Run the oven and check all functions.

**MAGNETRON TEMPERATURE FUSE TEST**

1. Disconnect the power supply cord, and then remove outer case.
2. Open the door and block it open.
3. Discharge high voltage capacitor.
4. A continuity check across the temperature fuse terminals should indicate a closed circuit. If the temperature of the magnetron reaches approximately 302°F(150°C), the temperature fuse opens. An open temperature fuse indicates overheating of the magnetron. Check for restricted air flow to the magnetron, especially the cooling fan air guide.



## WARNING

To avoid risk of electrical shock, personal injury, or death, disconnect electrical power source to unit, unless test procedures require power to be connected. Discharge capacitor through a resistor before attempting to service. Ensure all ground wires are connected before certifying unit as repaired and/or operational.

PROCEDURE  
LETTER

COMPONENT TEST

---

E                    **MAGNETRON TEMPERATURE FUSE TEST (cont'd)**

5. Reconnect all leads removed from components during testing.
6. Reinstall the outer case (cabinet).
7. Reconnect the power supply cord after the outer case is installed.
8. Run the oven and check all functions.

---

F                    **SECONDARY INTERLOCK SWITCH AND THIRD DOOR SWITCH TEST**

1. Disconnect the power supply cord, and then remove outer case.
2. Open the door and block it open.
3. Discharge high voltage capacitor.
4. Isolate the switch and connect the ohmmeter to the common (COM.) and normally open (NO) terminal of the switch. The meter should indicate an open circuit with the door open and a closed circuit with the door closed. If improper operation is indicated, replace the secondary interlock switch and third door switch.
5. Reconnect all leads removed from components during testing.
6. Reinstall the outer case (cabinet).
7. Reconnect the power supply cord after the outer case is installed.
8. Run the oven and check all functions.

---

G                    **PRIMARY INTERLOCK SYSTEM TEST**

DOOR SENSING SWITCH

1. Disconnect the power supply cord, and then remove outer case.
2. Open the door and block it open.
3. Discharge high voltage capacitor.
4. Isolate the switch and connect the ohmmeter to the common (COM.) and normally open (NO) terminal of the switch. The meter should indicate an open circuit with the door open and a closed circuit with the door closed. If improper operation is indicated, replace the door sensing switch.
5. Reconnect all leads removed from components during testing.
6. Reinstall the outer case (cabinet).
7. Reconnect the power supply cord after the outer case is installed.
8. Run the oven and check all functions.

***NOTE: If the door sensing switch contacts fail in the open position and the door is closed, the cooling fan motor, stirrer motor and oven light will be activated by RY1.***

## ! WARNING

To avoid risk of electrical shock, personal injury, or death, disconnect electrical power source to unit, unless test procedures require power to be connected. Discharge capacitor through a resistor before attempting to service. Ensure all ground wires are connected before certifying unit as repaired and/or operational.

PROCEDURE  
LETTER

COMPONENT TEST

### G PRIMARY INTERLOCK SYSTEM TEST (cont'd)

#### PRIMARY INTERLOCK RELAY (RY2)

1. Disconnect the power supply cord, and then remove outer case.
2. Open the door and block it open.
3. Discharge high voltage capacitor.
4. Disconnect two (2) wire leads from the male tab terminals of the Primary Interlock Relay. Check the state of the relay contacts using a ohmmeter. The relay contacts should be open. If the relay contacts are closed, replace the circuit board entirely or the relay itself.
5. Reconnect all leads removed from components during testing.
6. Reinstall the outer case (cabinet).
7. Reconnect the power supply cord after the outer case is installed.
8. Run the oven and check all functions.

### H MONITOR SWITCH TEST

1. Disconnect the power supply cord, and then remove outer case.
2. Open the door and block it open.
3. Discharge high voltage capacitor.
4. Before performing this test, make sure that the secondary interlock switch and the primary interlock relay are operating properly, according to the above Switch Test Procedure. Disconnect the wire lead from the monitor switch (COM) terminal. Check the monitor switch operation by using the ohmmeter as follows. When the door is open, the meter should indicate a closed circuit. When the monitor switch actuator is pushed by a screw driver through the lower latch hole on the front plate of the oven cavity with the door opened (in this condition the plunger of the monitor switch is pushed in), the meter should indicate an open circuit. If improper operation is indicated, the switch may be defective. After testing the monitor switch, reconnect the wire lead to the monitor switch (COM) terminal and check the continuity of the monitor circuit.
5. Reconnect all leads removed from components during testing.
6. Reinstall the outer case (cabinet).
7. Reconnect the power supply cord after the outer case is installed.
8. Run the oven and check all functions.

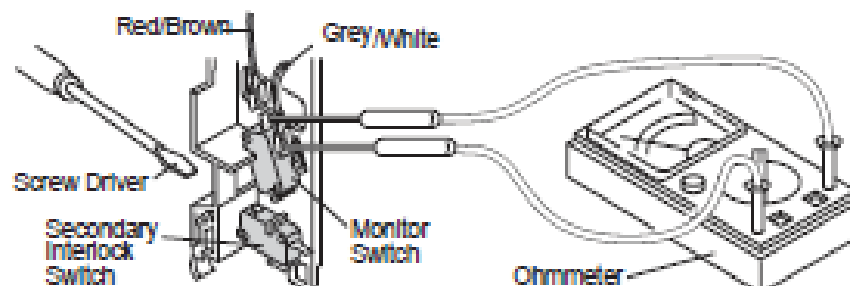

## **WARNING**

To avoid risk of electrical shock, personal injury, or death, disconnect electrical power source to unit, unless test procedures require power to be connected. Discharge capacitor through a resistor before attempting to service. Ensure all ground wires are connected before certifying unit as repaired and/or operational.

PROCEDURE  
LETTER

COMPONENT TEST

I

### **BLOWN MONITOR FUSE TEST**

1. Disconnect the power supply cord, and then remove outer case.
2. Open the door and block it open.
3. Discharge high voltage capacitor.
4. If the monitor fuse is blown when the door is opened, check the secondary interlock relay, primary interlock switch and monitor switch according to the "TEST PROCEDURE" for those switches before replacing the blown monitor fuse.

## **CAUTION**

***BEFORE REPLACING A BLOWN MONITOR FUSE, TEST THE PRIMARY INTERLOCK RELAY, SECONDARY INTERLOCK SWITCH, THIRD DOOR SWITCH, DOOR SENSING SWITCH AND MONITOR SWITCH FOR PROPER OPERATION.***

If the monitor fuse is blown by improper switch operation, the monitor fuse and monitor switch must be replaced with "monitor fuse and monitor switch assembly" part number FFS-BA016/KiT, even if the monitor switch operates normally. The monitor fuse and monitor switch assembly is comprised of a 20 ampere fuse and switch.

5. Reconnect all leads removed from components during testing.
6. Re-install the outer case (cabinet).
7. Reconnect the power supply cord after the outer case is installed.
8. Run the oven and check all functions.

J

### **HOOD THERMAL CUT-OUT TEST**

1. Disconnect the power supply cord, and then remove outer case.
2. Open the door and block it open.
3. Discharge high voltage capacitor.
4. A continuity check across the thermal cut-out terminals should indicate an open circuit unless the temperature of the thermal cut-out reaches approximately 140½F(60½C) or more. At that temperature, the contacts will close. The thermal cut-out opens automatically at approximately 113½F(45½C).
5. Reconnect all leads removed from components during testing.
6. Reinstall the outer case (cabinet).
7. Reconnect the power supply cord after the outer case is installed.
8. Run the oven and check all functions.

## ! WARNING

To avoid risk of electrical shock, personal injury, or death, disconnect electrical power source to unit, unless test procedures require power to be connected. Discharge capacitor through a resistor before attempting to service. Ensure all ground wires are connected before certifying unit as repaired and/or operational.

PROCEDURE  
LETTER

COMPONENT TEST

### K HOOD FAN MOTOR TEST

1. Disconnect the power supply cord, and then remove outer case.
2. Open the door and block it open.
3. Discharge high voltage capacitor.
4. If the motor does not turn, touch the FAN HI / LO button once (set hood fan motor power "HIGH") and check voltage between pins "1" and "2" (Blue and Black wires) of the 6 pin connector. If 120 Volts appear and the hood capacitor is good, replace the hood fan assembly. If 120 Volts does not appear, check the motor circuit. The resistance values of motor terminals are as follows:

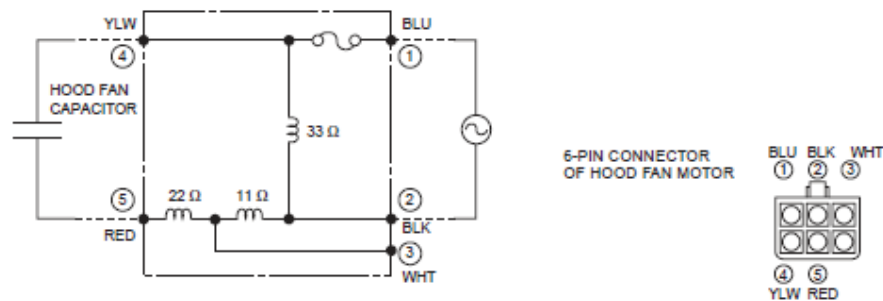

### L TOUCH CONTROL PANEL ASSEMBLY TEST

The touch control panel consists of circuits including semiconductors such as LSI, ICs, etc. Therefore, unlike conventional microwave ovens, proper maintenance cannot be performed with only a voltmeter and ohmmeter. In this service manual, the touch control panel assembly is divided into two units, Control Unit and Key Unit, and also the Control Unit is divided into two units, LSI Unit and Power Unit, and troubleshooting by unit replacement is described according to the symptoms indicated.

#### Before testing,

- 1) Disconnect the power supply cord, and then remove outer case. Refer to procedure of " HOOD EXHAUST LOUVER REMOVAL ", " REMOVAL OF OVEN FROM WALL " and " OUTER CASE REMOVAL ".
- 2) Open the door and block it open.
- 3) To discharge high voltage capacitor, wait for 60 seconds.
- 4) Remove two (2) screws holding the hood intake duct R to the oven cavity top plate and the base plate R. And remove the hood intake duct R.
- 5) Disconnect the leads to the primary of the power transformer.
- 6) Ensure that these leads remain isolated from other components and oven chassis by using insulation tape.



## WARNING

To avoid risk of electrical shock, personal injury, or death, disconnect electrical power source to unit, unless test procedures require power to be connected. Discharge capacitor through a resistor before attempting to service. Ensure all ground wires are connected before certifying unit as repaired and/or operational.

PROCEDURE  
LETTER

COMPONENT TEST

### L TOUCH CONTROL PANEL ASSEMBLY TEST (cont'd)

#### 1. Key Unit.

NOTE ;

- 1) Check key unit ribbon connection before replacement.
- 2) Reconnect all leads removed from components during testing.
- 3) Re-install the hood intake duct R with two (2) screws.
- 4) Re-install the outer case (cabinet).
- 5) Reconnect the power supply cord after the outer case is installed.
- 6) Run the oven and check all functions.

The following symptoms indicate a defective key unit.

- a) When touching the pads, a certain pad produces no signal at all.
- b) When touching a number pad, two figures or more are displayed.
- c) When touching the pads, sometimes a pad produces no signal.

If the key unit is defective.

- 1) Disconnect the power supply cord, and then remove outer case.
- 2) Open the door and block it open.
- 3) To discharge high voltage capacitor, wait for 60 seconds.
- 4) Replace the key unit.
- 5) Reconnect all leads removed from components during testing.
- 6) Re-install the outer case (cabinet).
- 7) Reconnect the power supply cord after the outer case is installed.
- 8) Run the oven and check all functions.

#### 2. Control Unit.

The following symptoms indicate a defective control unit. Before replacing the control unit, perform the Key unit test (Procedure M) to determine if control unit is faulty.

##### 2-1 In connection with pads.

- a) When touching the pads, a certain group of pads do not produce a signal.
- b) When touching the pads, no pads produce a signal.

##### 2-2 In connection with indicators

- a) At a certain digit, all or some segments do not light up.
- b) At a certain digit, brightness is low.
- c) Only one indicator does not light.
- d) The corresponding segments of all digits do not light up; or they continue to light up.
- e) Wrong figure appears.
- f) A certain group of indicators do not light up.
- g) The figure of all digits flicker.

##### 2-3 Other possible problems caused by defective control unit.

- a) Buzzer does not sound or continues to sound.
- b) Clock does not operate properly.
- c) Cooking is not possible.

## ⚠ WARNING

To avoid risk of electrical shock, personal injury, or death, disconnect electrical power source to unit, unless test procedures require power to be connected. Discharge capacitor through a resistor before attempting to service. Ensure all ground wires are connected before certifying unit as repaired and/or operational.

PROCEDURE  
LETTER

COMPONENT TEST

### L TOUCH CONTROL PANEL ASSEMBLY TEST (cont'd)

When testing is completed,

- 1) Disconnect the power supply cord.
- 2) Open the door and block it open.
- 3) To discharge high voltage capacitor, wait for 60 seconds.
- 4) Reconnect all leads removed from components during testing.
- 5) Re-install the hood intake duct R.
- 6) Re-install the outer case (cabinet).
- 7) Reconnect the power supply cord after the outer case is installed.
- 8) Run the oven and check all functions.

### M KEY UNIT TEST

1. Disconnect the power supply cord.
2. Open the door and block it open.
3. To discharge high voltage capacitor, wait for 60 seconds.
4. Remove the control panel assembly.
5. If the display fails to clear when the STOP/CLEAR pad is depressed, first verify the flat ribbon cable is making good contact, verify that the door sensing switch (stop switch) operates properly; that is the contacts are closed when the door is closed and open when the door is open. If the door sensing switch (stop switch) is good, disconnect the flat ribbon cable that connects the key unit to the control unit and make sure the door sensing switch is closed (either close the door or short the door sensing switch connector). Use the Key unit matrix indicated on the control panel schematic and place a jumper wire between the pins that correspond to the STOP/CLEAR pad making momentary contact. If the control unit responds by clearing with a beep the key unit is faulty and must be replaced. If the control unit does not respond, it is faulty and must be replaced. If a specific pad does not respond, the above method may be used (after clearing the control unit) to determine if the control unit or key pad is at fault.
6. Reconnect all leads removed from components during testing.
7. Re-install the control panel assembly.
8. Reconnect the power supply cord.
9. Run the oven and check all functions.

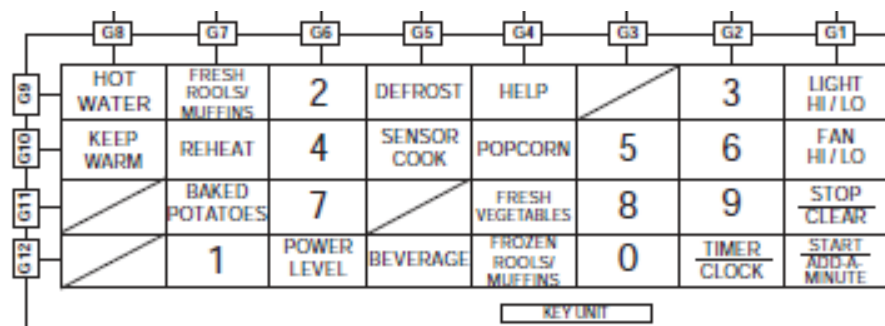



## **WARNING**

To avoid risk of electrical shock, personal injury, or death, disconnect electrical power source to unit, unless test procedures require power to be connected. Discharge capacitor through a resistor before attempting to service. Ensure all ground wires are connected before certifying unit as repaired and/or operational.

PROCEDURE  
LETTER

COMPONENT TEST

N

### RELAY TEST

1. Disconnect the power supply cord, and then remove outer case. Refer to procedure of " HOOD EXHAUST LOUVER REMOVAL ", " REMOVAL OF OVEN FROM WALL " and " OUTER CASE REMOVAL ".
2. Open the door and block it open.
3. To discharge high voltage capacitor, wait for 60 seconds.
4. Remove the hood intake duct R.
5. Disconnect the leads to the primary of the power transformer.
6. Ensure that these leads remain isolated from other components and oven chassis by using insulation tape.
7. After that procedure, re-connect the power supply cord.
8. Check voltage between normal open terminal of the relay RY2 and the normal open terminal of the relay RY1 on the control unit with an A.C. voltmeter.  
The meter should indicate 120 volts, if not check oven circuit. RY1, RY2, RY3, RY4, RY5 and RY6 Relay Test

These relays are operated by D.C. voltage

Check voltage at the relay coil with a D.C. voltmeter during the microwave cooking operation.

DC. Voltage indicated

Defective relay.

DC. Voltage not indicated

Check diode which is connected to the relay coil. If diode is good, control unit is defective.

RELAY SYMBOL	OPERATIONAL VOLTAGE	CONNECTED COMPONENTS
RY1	Approx. 25.6V D.C.	Oven lamp / Fan motor / Turntable motor
RY2(COOK)	Approx. 25.0V D.C.	Power transformer
RY3	Approx. 25.6V D.C.	Hood motor
RY4	Approx. 25.6V D.C.	Hood motor
RY5	Approx. 25.6V D.C.	Hood lamp
RY6	Approx. 25.6V D.C.	Hood lamp

9. Disconnect the power supply cord.
10. Open the door and block it open.
11. To discharge high voltage capacitor, wait for 60 seconds.
12. Reconnect all leads removed from components during testing.
13. Re-install the hood intake duct R.
14. Re-install the outer case (cabinet).
15. Reconnect the power supply cord after the outer case is installed.
16. Run the oven and check all functions.

## ! WARNING

To avoid risk of electrical shock, personal injury, or death, disconnect electrical power source to unit, unless test procedures require power to be connected. Discharge capacitor through a resistor before attempting to service. Ensure all ground wires are connected before certifying unit as repaired and/or operational.

PROCEDURE  
LETTER

COMPONENT TEST

### O DEFROST CENTER TEST

- (1) Open the door.
- (2) Place one cup of water in the center of the turntable tray in the oven cavity.
- (3) Touch Defrost, then #2 for " STEAKS/CHOPS "
- (4) Close the door.
- (5) Touch the " START " button.
- (6) The oven is in Defrost center cooking condition.
- (7) The oven will operate as follows.

Menu	1ST STAGE		2ND STAGE	
	LEVEL	TIME	LEVEL	TIME
Steaks/Chops 0.5lbs	60%	57sec.	40%	17sec.

- (8) If improper operation is indicated, the control unit is probably defective and should be checked.

### P FOIL PATTERN ON THE PRINTED WIRING BOARD TEST

To protect the electronic circuits, this model is provided with a fine foil pattern added to the primary on the PWB, this foil pattern acts as a fuse.

1. Foil pattern check and repairs.
  - 1) Disconnect the power supply cord.
  - 2) Open the door and block it open.
  - 3) To discharge high voltage capacitor, wait for 60 seconds.
  - 4) Remove the control unit, referring to the procedure of " CONTROL PANEL ASSEMBLY, CONTROL UNIT AND KEY UNIT REMOVAL ".
  - 5) Follow the troubleshooting guide given below for repair.

STEPS	OCCURRENCE	CAUSE OR CORRECTION
1	Only pattern at "a" is broken.	*Insert jumper wire J1 and solder.
2	Pattern at "a" and "b" are broken.	*Insert the coil RCILF2003YAZZ between "c" and "d".

- 6) Make a visual inspection of the varistor. Check for burned damage and examine the transformer with a tester for the presence of layer short-circuit (check the primary coil resistance which is approximately  $780\Omega \pm 10\%$ ). If any abnormal condition is detected, replace the defective parts.

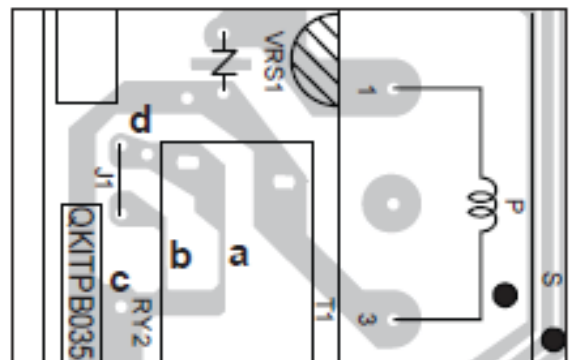

- 7) Reconnect all leads removed from components during testing.
- 8) Re-install the control unit to the control panel and re-install the control panel to the oven.



## WARNING

To avoid risk of electrical shock, personal injury, or death, disconnect electrical power source to unit, unless test procedures require power to be connected. Discharge capacitor through a resistor before attempting to service. Ensure all ground wires are connected before certifying unit as repaired and/or operational.

PROCEDURE  
LETTER

COMPONENT TEST

P

### FOIL PATTERN ON THE PRINTED WIRING BOARD TEST (cont'd)

- 9) Reconnect the power supply cord.
- 10) Run the oven and check all functions.
2. Follow the troubleshooting guide given below, if indicator does not light up after above check and repairs are finished.
  - 1) Disconnect the power supply cord, and then remove outer case. Refer to procedure of " HOOD EXHAUST LOUVER REMOVAL ", " REMOVAL OF OVEN FROM WALL " and " OUTER CASE REMOVAL ".
  - 2) Open the door and block it open.
  - 3) To discharge high voltage capacitor, wait for 60 seconds.
  - 4) Remove the hood intake duct R.
  - 5) Disconnect the leads to the primary of the power transformer.
  - 6) Ensure that these leads remain isolated from other components and oven chassis by using insulation tape.
  - 7) After that procedure, re-connect the power supply cord.
  - 8) Follow the troubleshooting guide given below for repair.

P

STEPS	OCCURRENCE	CAUSE OR CORRECTION
1	The rated AC voltage is not present between the normal open terminal of the relay RY2 and the normal open terminal of the relay RY1.	Check supply voltage and oven power cord.
2	The rated AC voltage is present at primary side of low voltage transformer.	Low voltage transformer or secondary circuit defective. Check and repair.

- 9) Disconnect the power supply cord.
- 10) Open the door and block it open.
- 11) To discharge high voltage capacitor, wait for 60 seconds.
- 12) Reconnect all leads removed from components during testing.
- 13) Re-install the hood intake duct R.
- 14) Re-install the outer case (cabinet).
- 15) Reconnect the power supply cord after the outer case is installed.
- 16) Run the oven and check all functions.

Q

### NOISE FILTER TEST

1. Disconnect the power supply cord, and then remove outer case.
2. Open the door and block it open.
3. Discharge high voltage capacitor.
4. Disconnect the leads to the primary of the power transformer.
5. Using an ohm-meter, check between the terminals as described in the following table:

**! WARNING**

To avoid risk of electrical shock, personal injury, or death, disconnect electrical power source to unit, unless test procedures require power to be connected. Discharge capacitor through a resistor before attempting to service. Ensure all ground wires are connected before certifying unit as repaired and/or operational.

PROCEDURE  
LETTER

COMPONENT TEST

**Q NOISE FILTER TEST (cont'd)**

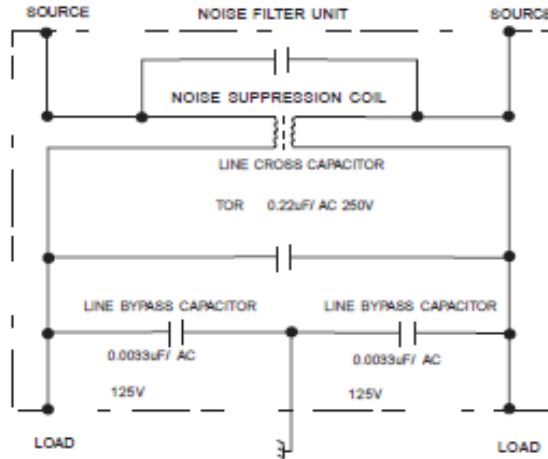

MEASURING POINT	INDICATION OF OHM-METER
Between source and source	Open Circuit
Between load and source	Short Circuit
Between load and source	Short Circuit

If incorrect readings are obtained, replace the noise filter.

6. Reconnect all leads removed from components during testing.
7. Re-install the outer case (cabinet).
8. Reconnect the power supply cord after the outer case is installed.
9. Run the oven and check all functions.

**! WARNING**

The oven should be fully assembled before following procedure.

**R AH SENSOR TEST**

**Checking the initial sensor cooking condition**

- (1) The oven should be plugged in at least two minutes before sensor cooking.
- (2) Room temperature should not exceed 95°F (35°C).
- (3) The unit should not be installed in any area where heat and steam are generated. The unit should not be installed, for example, next to a conventional surface unit. Refer to the INSTALLATION INSTRUCTIONS of the operation manual.
- (4) Exhaust vents are provided on the back of the unit for proper cooling and air flow in the cavity. To permit adequate ventilation, be sure to install so as not to block these vents. There should be some space for air circulation.
- (5) Be sure the exterior of the cooking container and the interior of the oven are dry. Wipe off any moisture with a dry cloth or paper towel.
- (6) The Sensor works with food at normal storage temperature. For example, chicken pieces would be at refrigerator temperature and canned soup at room temperature.
- (7) Avoid using aerosol sprays or cleaning solvents near the oven while using Sensor settings. The sensor will detect the vapor given off by the spray and turn off before food is properly cooked.

## **WARNING**

To avoid risk of electrical shock, personal injury, or death, disconnect electrical power source to unit, unless test procedures require power to be connected. Discharge capacitor through a resistor before attempting to service. Ensure all ground wires are connected before certifying unit as repaired and/or operational.

PROCEDURE  
LETTER

COMPONENT TEST

R      **AH SENSOR TEST**

(8) If the sensor has not detected the vapor of the food, ERROR will appear and the oven will shut off.

## **WARNING**

The oven should be fully assembled before following procedure.

### **Water load cooking test**

Make sure the oven has been plugged in at least two minutes before checking sensor cook operation. The cabinet should be installed and screws tightened.

(1) Fill approximately 200 milliliters (7.2 oz) of tap water in a 1000 milliliter measuring cup.

(2) Place the container on the center of tray in the oven cavity.

(3) Close the door.

(4) Touch the TIMER/CLOCK once, the POWER LEVEL pad twice, closer the door, touch the START pad once, open the door touch the number pad 4 once, closer door then touch START . Now, the oven is in the sensor cooking condition, and “ AH20 “ , “ SENSOR “ and “ COOK “ will appear in the display.

(5) The oven will operate for the first 32 seconds, without generating microwave energy.

NOTE: ERROR will appear if the door is opened or STOP/CLEAR pad is touched during first stage of sensor cooking.

(6) After approximately 32 seconds, microwave energy is produced.

If ERROR is displayed or the oven does not turn off, replace the AH sensor or check the control unit, refer to explanation below. If the oven stops after 5 minutes and ERROR is displayed, the AH sensor is normal. Check other parts except the AH sensor.

### **TESTING METHOD FOR AH SENSOR AND/OR CONTROL UNIT**

To determine if the sensor is defective, the simplest method is to replace it with a new replacement sensor.

(1) Disconnect the power supply cord, and then remove outer case.

(2) Open the door and block it open.

(3) Discharge high voltage capacitor. (4) Remove the AH sensor.

(5) Install the new AH sensor.

(6) Reconnect all leads removed from components during testing.

(7) Re-install the outer case (cabinet).

(8) Reconnect the power supply cord after the outer case is installed.

(9) Reconnect the oven to the power supply and check the sensor cook operation as follows:

9-1. Fill approximately 200 milliliters (7.2 oz) of tap water in a 1000 milliliter measuring cup.

9-2. Place the container on the center of tray in the oven cavity.

9-3. Close the door.

9-4. Touch the TIMER/CLOCK pad once, the POWER LEVEL pad twice, the START pad once, the number pad 1 once and the number pad 4 once.

9-5. The control panel is in automatic Sensor operation.

9-6. The oven turns off automatically, and the time for detecting moisture will be displayed.

If new sensor dose not operate properly, the problem is with the control unit, and refer to explanation below.

## ! WARNING

To avoid risk of electrical shock, personal injury, or death, disconnect electrical power source to unit, unless test procedures require power to be connected. Discharge capacitor through a resistor before attempting to service. Ensure all ground wires are connected before certifying unit as repaired and/or operational.

PROCEDURE  
LETTER

COMPONENT TEST

### R Checking Control Unit

- (1) Disconnect the power supply cord, and then remove outer case.
- (2) Open the door and block it open.
- (3) Discharge high voltage capacitor.
- (4) Disconnect the sensor connector that is mounted to control panel.
- (5) Then connect the dummy resistor circuit (see fig.) to the sensor connector of control panel.
- (6) Disconnect the leads to the primary of the power transformer.
- (7) Ensure that these leads remain isolated from other components and oven chassis by using insulation tape.
- (8) After that procedure, re-connect the power supply cord.
- (9) Check the sensor cook operation proceed as follows:
  - 9-1. Touch the TIMER/CLOCK pad once, the POWER LEVEL pad twice, the START pad once and the number pad 1 once and the number pad 4 once.
  - 9-2. The control panel is in the sensor cooking operation.
  - 9-3. After approximately 65 seconds, push plunger of select switch for more than 3 seconds. This condition is same as judgement by AH sensor.
  - 9-4. After approximately 3 seconds, the display shows  $\hat{X} X . X X \hat{}$  which is the time for detecting moisture.
 

If the above is not the case, the control unit is probably defective. If the above is proper, the AH sensor is probably defective.
- (10) Disconnect the power supply cord, and then remove outer case.
- (11) Open the door and block it open.
- (12) Discharge high voltage capacitor.
- (13) Disconnect the dummy resistor circuit from the sensor connector of control panel.
- (14) Carry out necessary repair.
- (15) Reconnect all leads removed from components during testing and repairing.
- (16) Re-install the outer case (cabinet).
- (17) Reconnect the power supply cord after the outer case is installed. Run the oven and check all functions.
- (18) Carry out Water load cooking test again and ensure that the oven works properly.

R1, R2 : 22W  $\pm$  1% 1/2W  
 R3 : 4.3kW  $\pm$  5% 1/4W  
 R4 : 1MW  $\pm$  5% 1/4W

Sensor Dummy Resistor Circuit

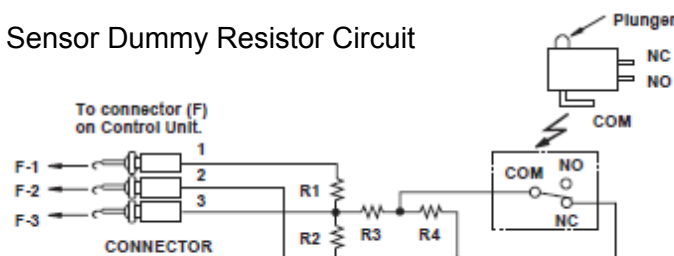



## ABSOLUTE HUMIDITY SENSOR CIRCUIT

### (1) Structure of Absolute Humidity Sensor

The absolute humidity sensor includes two thermistors as shown in the illustration. One thermistor is housed in the closed vessel filled with dry air while another in the open vessel. Each sensor is provided with the protective cover made of metal mesh to be protected from the external airflow.

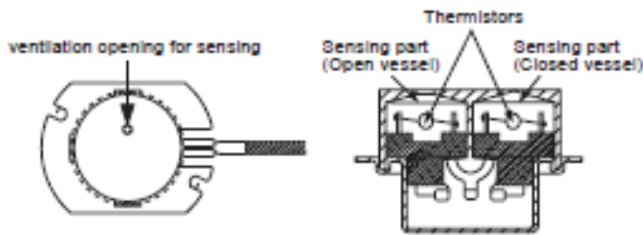

### (2) Operational Principle of Absolute Humidity Sensor

The figure below shows the basic structure of an absolute humidity sensor. A bridge circuit is formed by two thermistors and two resistors (R1 and R2). The output of the bridge circuit is to be amplified by the operational amplifier.

Each thermistor is supplied with a current to keep it heated at about 150°C (302°F), the resultant heat is dissipated in the air and if the two thermistors are placed in different humidity conditions they show different degrees of heat conductivity leading to a potential difference between them causing an output voltage from the bridge circuit, the intensity of which is increased as the absolute humidity of the air increases. Since the output is very minute, it is amplified by the operational amplifier.

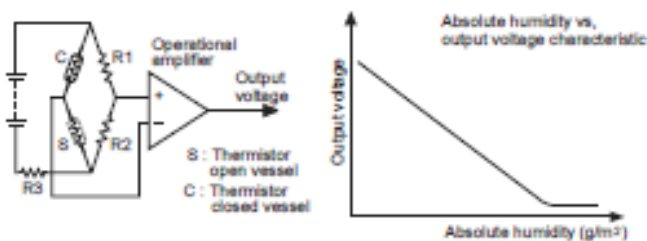

### (3) Detector Circuit of Absolute Humidity Sensor Circuit

This detector circuit is used to detect the output voltage of the absolute humidity circuit to allow the LSI to control sensor cooking of the unit. When the unit is set in the sensor cooking mode, 16 seconds clearing cycle occurs than the detector circuit starts to function and the LSI observes the initial voltage available at its AN1 terminal.

With this voltage given, the switches SW1 to SW5 in the LSI are turned on in such a way as to change the resistance values in parallel with R98 ~ R102 of IC2. Changing the resistance values results in that there is the same potential at both F-3 terminal of the absolute humidity sensor and AN0 terminal of the LSI. The voltage of AN1 terminal will indicate about -2.5V. This initial balancing is set up about 16 seconds after the unit is put in the Sensor Cooking mode. As the sensor cooking proceeds, the food is heated to generate moisture by which the resistance balance the bridge circuit is deviated to increase the voltage available at AN1 terminal of the LSI. Then the LSI observes that voltage at AN1 terminal and compares it with its initial value, and when the comparison rate reaches the preset value (fixed for each menu to be cooked), the LSI causes the unit to stop sensor cooking; thereafter, the unit goes in the next operation automatically.

When the LSI starts to detect the initial voltage at AN1 terminal 16 seconds after the unit has been put in the Sensor Cooking mode, if it is not possible to balance, of the bridge circuit due to disconnection of the absolute humidity sensor, ERROR will appear on the display and the cooking is stopped.



## Absolute humidity sensor circuit

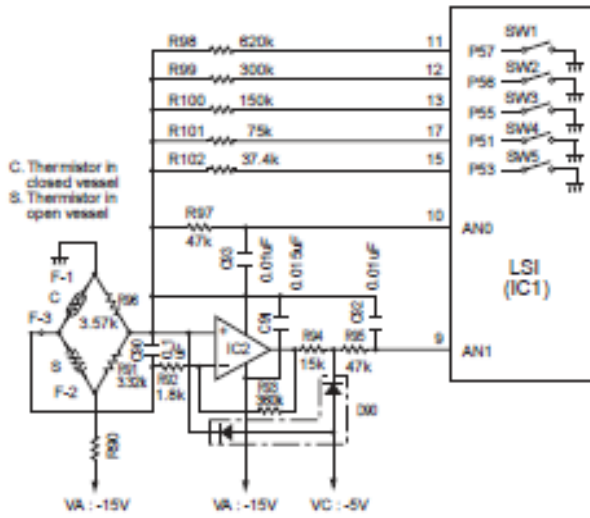

## DANGER

- Microwave ovens contain circuitry capable of producing very high voltage and current, contact with following parts may result in severe, possibly fatal, electric shock.
- (Example) High Voltage Capacitor, Power Transformer, Magnetron, High Voltage Rectifier Assembly, High Voltage Harness etc.
- Avoid possible exposure to microwave energy. Please follow the instructions below before operating the oven.

1. Disconnect the power supply cord.
2. Make sure that a definite "click" can be heard when the microwave oven door is unlatched. (Hold the door in a closed position with one hand, then push the door open button with the other, this causes the latch leads system. to rise, it is then possible to hear a "click" as the door generating switches operate.)
3. Visually check the door and cavity face plate for damage (dents, cracks, signs of arcing etc.).
1. Door does not close firmly.
2. Door hinge, support or latch hook is damaged.
3. The door gasket or seal is damaged.
4. The door is bent or warped.
5. There are defective parts in the door interlock
6. There are defective parts in the microwave and transmission assembly.
7. There is visible damage to the oven.

Carry out any remedial work that is necessary before operating the oven.

Do not operate the oven if any of the following conditions exist;

Do not operate the oven:

1. Without the RF gasket (Magnetron).
2. If the wave guide or oven cavity are not intact.
3. If the door is not closed.
4. If the outer case (cabinet) is not fitted.

## DANGER

To prevent an electric shock, take the following precautions.

1. Before wiring,
  - 1) Disconnect the power supply cord.
  - 2) Open the door block it open.
  - 3) Discharge the high voltage capacitor and wait for 60 seconds.
2. Don't let the wire leads touch to the following parts;
  - 1) High voltage parts:  
Magnetron, High voltage transformer, High voltage capacitor and High voltage rectifier assembly.
  - 2) Hot parts:  
Oven lamp, Magnetron, High voltage transformer and Oven cavity.
- 3) Sharp edge:  
Bottom plate, Oven cavity, Wave guide flange, Chassis support and other metallic plate.
- 4) Movable parts (to prevent a fault)  
Fan blade, Fan motor, Switch, Open lever, Open button.
3. Do not catch the wire leads in the outer case cabinet.
4. Insert the positive lock connector until its pin is locked and make sure that the wire leads do not come off even if the wire leads are pulled.
5. To prevent an error function, connect the wire leads correctly, referring to the Pictorial Diagram.

### **THE FOLLOWING ADJUSTMENTS OR COMPONENT REPLACEMENT CAN BE PERFORMED WITHOUT REMOVING THE OVEN FROM THE WALL**

1. Hood lamps, sockets, grease filter and charcoal filter.
2. Base cover and hood lamp glass assembly.
3. Turntable motor.
4. Hood exhaust louver.
5. Control panel assembly or components.

### HOOD EXHAUST LOUVER REMOVAL

1. Disconnect the power supply cord.
2. Open the door and block it open.
3. To discharge the high voltage capacitor, wait for 60 seconds.
4. Remove the two (2) screws holding the hood exhaust louver to the oven cavity front face plate.
5. Pull the hood exhaust louver from the oven cavity.
6. Now, the hood exhaust louver is free.

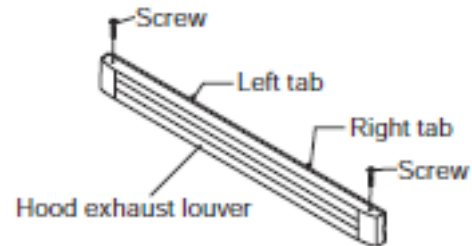

### REMOVAL OF OVEN FROM WALL (Two persons recommended to remove the oven)

1. Disconnect the power supply cord, and uncoil the power supply cord.
2. To discharge the high voltage capacitor, wait for 60 seconds.
3. Remove the turntable tray and support from the oven cavity.
4. If the exhaust damper assembly is installed, remove the one (1) screw holding the exhaust damper assembly to the rear stay, and remove the exhaust damper assembly by sliding it backward.
5. Remove the two (2) screws holding the oven
6. (outer case cabinet) to the top cabinet.
6. While supporting the front of the oven, pull down the two (2) mounting levers and release the oven from the unit mounting plate.
7. Pull the power cord out of the wall cabinet and remove the oven.
8. The oven is now free and can be placed on the work surface selected for servicing the oven.
9. Installation is the reverse of this procedure.

### OUTER CASE REMOVAL

Remove the oven from the wall, referring to "REMOVAL OF OVEN FROM WALL" and proceed as follows;

1. Disconnect the power supply cord.
2. Open the door and block it open.
3. To discharge the high voltage capacitor, wait for 60 seconds.
4. Remove four (4) screws holding the rear stay to the hood fan motor or the oven, and remove it.
5. Remove the six (6) screws from the rear of the outer case cabinet and one (1) screw at front.
6. Slide the outer case cabinet back about 1 inch (3 cm) to free it from retaining clips on the cavity face plate.
7. Disconnect the three (3) pin connector of the power supply cord from the wiring harness and remove the power supply cord together with the
8. outer case.
8. Nip the cord bushing with bushing pliers and release it from the outer case cabinet.
9. Remove the cord bushing and the power supply cord from the outer case cabinet.
10. Now, the power supply cord is free.



#### CAUTION

- DISCONNECT OVEN FROM POWER SUPPLY BEFORE REMOVING OUTER CASE.
- DISCHARGE THE HIGH VOLTAGE CAPACITOR BEFORE TOUCHING ANY OVEN COMPONENTS OR WIRING.

## POWER TRANSFORMER REMOVAL

1. Disconnect the power supply cord, remove the oven from wall, and remove outer case. (Refer to procedure of "REMOVAL OF OVEN FROM WALL" AND "OUTER CASE REMOVAL".) And proceed as follows.
2. Open the door and block it open.
3. To discharge the high voltage capacitor, wait for 60 seconds.
4. Remove three (3) screws holding the hood intake duct R to the oven cavity top plate, the oven cavity front flange and the fan duct. And remove the hood intake duct R.
5. Disconnect main wire harness from transformer.
6. Disconnect high voltage wire A from the transformer.
7. Disconnect filament leads of transformer from the magnetron and capacitor.
8. Remove two (2) screws holding the transformer to base plate R.

### Re-install

1. Install by sliding the transformer on the base plate R with its primary terminals toward the outer case.
2. Secure the transformer with two (2) screws to base plate R.
3. Re-connect wire leads (primary and high voltage) to the transformer and filament leads of transformer to magnetron and high voltage capacitor. Refer to "PICTORIAL DIAGRAM".
4. Re-install the hood intake duct R to the oven cavity top plate, the oven cavity front flange and the fan duct with three (3) screws.
5. Re-install the outer case and check that oven is operating properly.



### CAUTION

MAKE SURE THE WIRE LEADS  
NEVER TOUCH THE FAN BLADE.

## HOOD FAN MOTOR REMOVAL

1. Disconnect the power supply cord and remove the oven from wall and remove outer case. (Refer to procedure of "Removal of Oven from Wall" and "Outer case Removal")
2. Open the door and block it open.
3. To discharge the high voltage capacitor, wait for 60 seconds.
4. Disconnect the 6-pin connector of the hood fan motor from the main wire harness located at the right edge of the oven cavity top plate and release the snap band from the hood duct.
5. Remove the hood fan motor from the oven cavity top plate by lifting it up.
6. Now, the hood fan motor is free.

## MAGNETRON REMOVAL

1. Disconnect the power supply cord, remove the oven from wall and remove outer case (Refer to procedure of "Removal of Oven from Wall" and "Outer case Removal".)
2. Open the door and block it open.
3. To discharge the high voltage capacitor, wait for 60 seconds.
4. Remove the three (3) screws holding the hood intake duct R to the oven cavity top plate, the oven cavity front flange and the fan duct. And remove the hood intake duct R.
5. Disconnect the high voltage wire lead of the high voltage rectifier assembly from the magnetron.
6. Disconnect the filament lead of the transformer from the magnetron.
7. Remove the one (1) screw holding the hood duct R to the oven cavity top plate. And remove the hood duct R from the oven cavity top plate R.
8. Remove the magnetron duct from the oven cavity, by releasing the tab of the magnetron duct from the oven cavity top plate.
9. Carefully remove four (4) mounting screws holding the magnetron to waveguide. When removing the screws hold the magnetron to prevent it from falling.

**MAGNETRON REMOVAL (cont'd)**

10. Remove the magnetron from the unit with care so the magnetron tube should not be hit by any metal object around the tube.

 **WARNING**

WHEN REPLACING THE MAGNETRON, BE SURE THE R.F. GASKET IS IN PLACE AND MOUNTING SCREWS ARE TIGHTENED SECURELY.

**HIGH VOLTAGE RECTIFIER AND HIGH VOLTAGE CAPACITOR REMOVAL**

1. Disconnect the power supply cord, remove the oven from wall and remove outer case (Refer to procedure of "Removal of Oven from Wall" and "Outer case Removal".)
2. Open the door and block it open.
3. To discharge the high voltage capacitor, wait for 60 seconds.
4. Remove the three (3) screws holding the hood intake duct R to the oven cavity top plate, the oven cavity front flange and the fan duct. And remove the hood intake duct R.
5. Disconnect the high voltage wire lead with high voltage rectifier from the magnetron.
6. Disconnect filament lead of the transformer from high voltage capacitor.
7. Disconnect high voltage wire A from capacitor.
8. Remove the fan duct assembly from the oven cavity, referring to the procedure of "COOLING FAN MOTOR REMOVAL"
9. Remove one (1) screw holding capacitor holder and high voltage rectifier to the fan duct.
10. Disconnect the high voltage rectifier assembly from the high voltage capacitor.
11. Now, the high voltage rectifier assembly is free.
12. Remove capacitor from the holder.
13. Now, the high voltage capacitor is free.

**WARNING**

WHEN REPLACING THE HIGH VOLTAGE RECTIFIER ASSEMBLY, THE GROUND SIDE TERMINAL MUST BE SECURED FIRMLY WITH A GROUNDING SCREW.

**HOOD FAN THERMAL CUT-OUT REMOVAL**

1. Disconnect the power supply cord and remove the oven from wall and remove outer case. (Refer to procedure of "Removal of Oven from Wall" and "Outer case Removal")
2. Open the door and block it open.
3. To discharge the high voltage capacitor, wait for 60 seconds.
4. Remove the three (3) screws holding the hood intake duct R to the oven cavity top plate, the oven cavity front flange and the fan duct. And remove the hood intake duct R.
5. Disconnect the wire leads from the hood fan thermal cut-out.
6. Remove one (1) screw holding the thermal cut-out to the flange of base plate R (turntable motor side).
7. Remove the hood fan thermal cut-out from the base plate R.
8. Now, the hood fan thermal cut-out is free.

**THERMAL CUT-OUT (CAVITY) REMOVAL**

1. Disconnect the power supply cord and remove the oven from wall and remove outer case. (Refer to procedure of "Removal of Oven from Wall" and "Outer case Removal")
2. Open the door and block it open.
3. To discharge the high voltage capacitor, wait for 60 seconds.
4. Disconnect the wire leads from the thermal cut-out (cavity).
5. Remove the thermal cut-out (cavity) from the holder at the oven cavity bottom plate.
6. Now, the thermal cut-out (cavity) is free.

## TEMPERATURE FUSE (MAGNETRON) REMOVAL

1. Disconnect the power supply cord and remove the oven from wall and remove outer case. (Refer to procedure of "Removal of Oven from Wall" and "Outer case Removal")
2. Open the door and block it open.
3. To discharge the high voltage capacitor, wait for 60 seconds.
4. Remove the fan duct assembly from the oven cavity, referring to the procedure of

" COOLING FAN MOTOR REMOVAL".

5. Disconnect the wire leads from the temperature fuse (Magnetron).
6. Remove the one (1) screw holding the temperature fuse (Magnetron) to the fan duct.
7. Now, the temperature fuse (Magnetron) is free.

## COOLING FAN MOTOR REMOVAL

1. Disconnect the power supply cord, remove the oven from wall and remove outer case (Refer to procedure of "Removal of Oven from Wall" and "Outer case Removal".)
2. Open the door and block it open.
3. To discharge the high voltage capacitor, wait for 60 seconds.
4. Remove the three (3) screws holding the hood intake duct R to the oven cavity top plate, the oven cavity front flange and the fan duct. And remove the hood intake duct R.
5. Remove the one (1) screw holding the hood duct R to the oven cavity top plate. And remove the hood duct R.
6. Disconnect the wire leads from the fan motor.
7. Disconnect the high voltage wire lead with the high voltage rectifier from the magnetron.
8. Disconnect the filament lead of the transformer from the high voltage capacitor.
9. Disconnect the high voltage wire A from the capacitor.
10. Release the wire leads from the hole of the fan duct.
11. Remove two (2) screws holding the fan duct to oven cavity top plate and the base plate R.
12. Remove the fan duct assembly from the oven cavity.
13. Remove the fan blade from the fan motor shaft according the following procedure.
14. Hold the edge of the rotor of the fan motor by using a pair of groove joint pliers.

**CAUTION**

- Make sure that any pieces do not enter the gap between the rotor and the stator of the fan motor because the rotor is easily shaven by pliers and metal pieces may be produced.
- Do not touch the pliers to the coil of the fan motor because the coil may be cut or damaged.
- Do not disfigure the bracket by touching with the pliers.

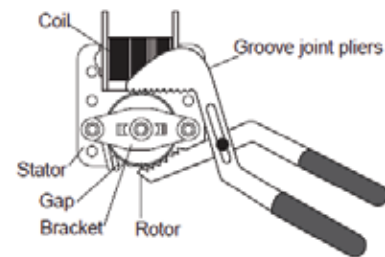

Rear View

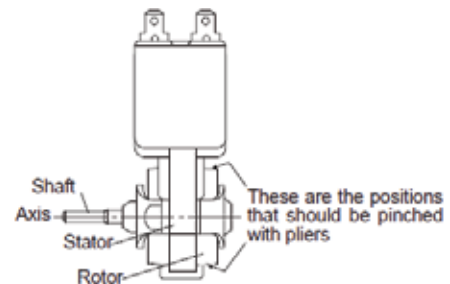

Side View

## COOLING FAN MOTOR REMOVAL (cont'd)

15. Remove the fan blade from the shaft of the fan motor by pulling and rotating the fan blade with your hand.
16. Now, the fan blade will be free.

 **CAUTION**

**Do not reuse the removed fan blade because the hole (for shaft) may be larger than normal.**

17. Remove the two (2) screws holding the fan motor to the fan duct.
18. Now, the fan motor is free.

**INSTALLATION**

1. Install the fan blade to the fan motor shaft according to the following procedure.
2. Hold the center of the bracket which supports the shaft of the fan motor on the flat table.
3. Install the fan blade to the shaft of fan motor by pushing the fan blade with a small, light weight, ball peen hammer or rubber mallet.
4. Install the fan motor to the hood duct with the two (2) screws.

 **CAUTION**

- Do not hit the fan blade with excessive force when installing because the bracket may be disfigured.
- Make sure that the fan blade rotates smooth after installation.
- Make sure that the axis of the shaft is not slanted.

5. Install the fan duct to the oven cavity top plate and base plate R with the two (2) screws.
6. Reconnect the wire leads to the fan motor, magnetron and high voltage capacitor, referring to the pictorial diagram.

7. Re-install the wire leads to the hole of the fan duct.
8. Re-install the hood intake duct R to the oven cavity top plate, the oven cavity front flange and the fan duct with the three (3) screws.
9. Refer to procedure of "OUTER CASE REMOVAL". And reverse their procedure. And re-install the outer case.

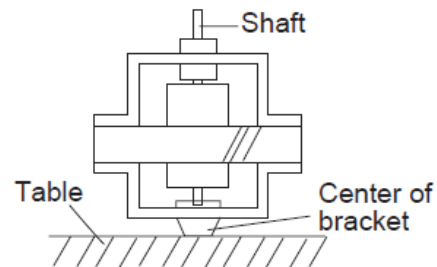



## TURNTABLE MOTOR AND FOOD LAMP SOCKETS REMOVAL

1. Disconnect the power supply cord.
2. Open the door and block it open.
3. To discharge the high voltage capacitor, wait for 60 seconds.
4. Remove the one (1) screw holding the base cover to the oven cavity back plate.
5. Remove the three (3) screws holding the base cover to the oven cavity front face plate.
6. Open the base cover.
7. Release the two hood lamp sockets from the base cover.
8. Remove the base cover from the oven cavity by pulling down and moving to the left slightly.

### TURNTABLE MOTOR

9. Disconnect the wire leads from the turntable motor.
10. Remove one (1) screw holding turntable motor to the oven cavity.
11. Now the turntable motor is free.

### HOOD LAMP SOCKET

12. Screw the hood lamp off from the lamp socket.
13. Disconnect the wire leads from the lamp socket by pushing the terminal hole of the lamp socket with the small flat type screw driver.
14. Now, the lamp socket is free.

## OVEN LAMP AND LAMP SOCKET REMOVAL

1. Disconnect the power supply cord, remove the oven from the wall and remove the outer case. (Refer to procedure of "REMOVAL OF OVEN FROM WALL" and "OUTER CASE REMOVAL".). And proceed as follows.
2. Open the door and block it open.
3. To discharge the high voltage capacitor, wait for 60 seconds.
4. Remove the three (3) screws holding the hood intake duct R to the oven cavity top plate, the oven cavity front flange and the fan duct. And remove the hood intake duct R.
5. Turn the lamp socket and release it from the magnetron duct.
6. Screw the oven lamp off from the lamp socket.
7. Now, the oven lamp is free.

8. Pull the wire leads from the oven lamp socket by pushing the terminal hole of the oven lamp socket with the small flat type screw driver.
9. Now, the oven lamp socket is free.

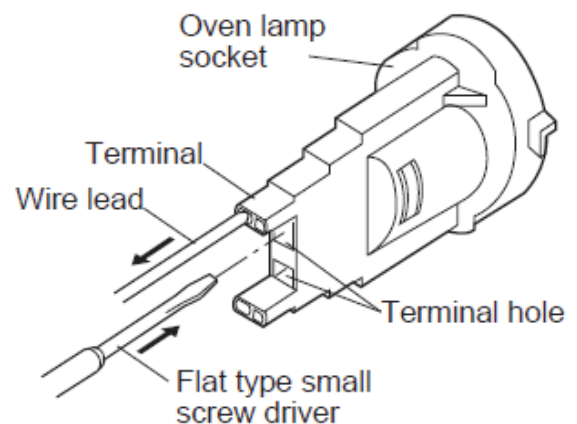

### POSITIVE LOCK® CONNECTOR (NO-CASE TYPE) REMOVAL

1. Disconnect the power supply cord and remove the oven from wall and remove outer case. (Refer to procedure Terminal of "Removal of Oven from Wall" and "Outer case Removal")
2. Open the door and block it open.
3. To discharge the high voltage capacitor, wait for 60 seconds.
4. Push the lever of positive lock® connector.
5. Pull down on the positive lock® connector.

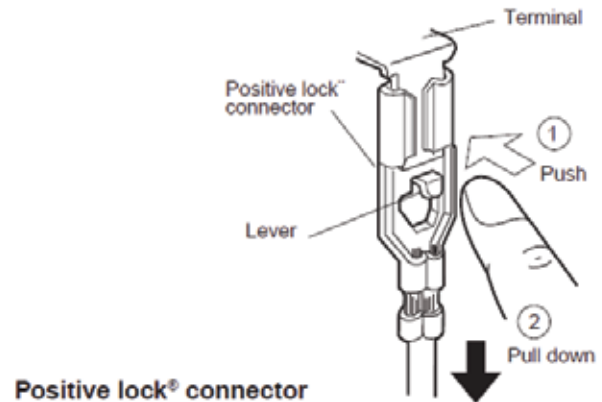

### CAUTION

WHEN CONNECTING THE POSITIVE LOCK® CONNECTORS TO THE TERMINALS, INSTALL THE POSITIVE LOCK® SO THAT THE LEVER FACES YOU.

### CONTROL PANEL ASSEMBLY, CONTROL UNIT AND KEY UNIT REMOVAL

1. Disconnect the power supply cord.
2. Open the door and block it open.
3. To discharge the high voltage capacitor, wait for 60 seconds.
4. Remove three (3) screws holding the hood exhaust louver to oven cavity front face plate.
5. Remove the hood exhaust louver from the oven by pushing the right and left tabs of the hood exhaust louver. (Refer to procedure of "HOOD EXHAUST LOUVER REMOVAL")
6. Remove one (1) screw holding the control panel to the oven cavity front face plate.
7. Release the control panel from the oven cavity front face plate by lifting it up.
8. Disconnect the wire leads from the relays RY1 and RY2.
9. Disconnect the connectors CN-A, CN-B and CN-E from the control unit.
10. Remove the control panel assembly from the oven.
11. Now, the control panel assembly is free.
12. Disconnect the connector CN-G from the control unit.
13. Remove the two (2) screws holding the LCD holder to the key fixing plate.
14. Remove two (2) screws holding the power unit to the key fixing plate.
15. Release the two (2) tabs holding the power unit to the key fixing plate.
16. Release the three (3) tabs holding the LCD to the LCD holder.
17. Release the two (2) tabs holding the LSI unit to the LCD holder.
18. Remove the LCD holder and the LED sheet.
19. Now, the control unit is free.
20. Remove the one (1) screw holding the key fixing plate to the control panel.
21. Release the six (6) tabs holding the key fixing plate to the control panel.

22. Remove the key fixing plate from the control panel.
23. Remove the key unit from the key fixing plate.
24. Now, the key unit is free

## NOTES FOR KEY UNIT REPLACEMENT

1. Do not reuse the torn key unit because the performance of the adhesive becomes weak.
2. Before attaching a new key unit, wipe off remaining adhesive on the key fixing plate surfaces completely with a soft cloth soaked in alcohol.
3. When attaching the key unit to the key fixing plate, adjust the upper edge and right edge of the key unit to the correct position of key fixing plate. See key unit location.
4. Stick the key unit firmly to the key fixing plate by rubbing with soft cloth not to scratch.

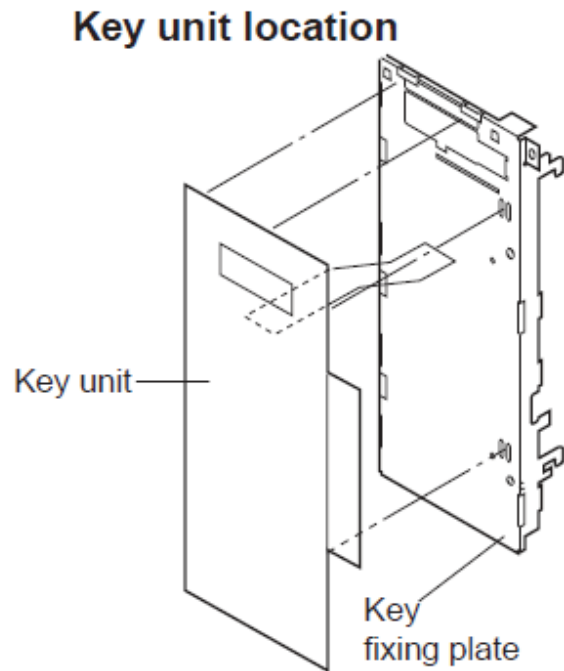

## DOOR SENSING SWITCH, SECONDARY INTERLOCK SWITCH, THIRD DOOR AND MONITOR-SWITCH REMOVAL

1. Disconnect the power supply cord and remove the oven from wall and remove outer case. (Refer to procedure of "Removal of Oven from Wall" and "Outer case Removal")
2. Open the door and block it open.
3. Discharge high voltage capacitor.
4. Remove the control panel assembly, referring to the procedure of "CONTROL PANEL ASSEMBLY, CONTROL UNIT AND KEY UNIT REMOVAL".
5. Remove the two (2) screws holding the latch hook to the oven cavity front flange.
6. Remove the latch hook from the oven cavity front flange.
7. Disconnect the wire leads of each switch.
8. Remove each switch from the latch hook by pushing the one (1) stopper tub holding each switch.

9. Now, each switch is free.

### Re-install

1. Re-install each switch in its place. The secondary interlock switch is in the lower position, door sensing switch is in the upper position, the third door switch is in the upper vertical position and the monitor switch is in the middle position.
2. Re-connect wire leads to each switch. Refer to pictorial diagram.
3. Secure the latch hook (with two (2) mounting screws) to oven cavity front flange.
4. Make sure that the monitor switch is operating properly and check continuity of the monitor circuit. Refer to chapter "Test Procedure" and "Adjustment procedure".

### DOOR SENSING SWITCH, SECONDARY INTERLOCK SWITCH, THIRD DOOR SWITCH AND MONITOR SWITCH ADJUSTMENT

1. Disconnect the power supply cord and remove the oven from wall and remove outer case. (Refer to procedure of "Removal of Oven from Wall" and "Outer case Removal")
2. Open the door and block it open.
3. Discharge high voltage capacitor.
4. Remove the control panel assembly, referring to the procedure of "CONTROL PANEL ASSEMBLY, CONTROL UNIT AND KEY UNIT REMOVAL".

***If the door sensing switch, secondary interlock switch and monitor switch do not operate properly due to a misadjustment, the following adjustment should be made.***

5. Loosen the two (2) screws holding latch hook to the oven cavity front flange.
6. With door closed, adjust latch hook by moving it back and forth, and up and down. In and out play of the door allowed by the upper and lower position of the latch hook should be less than 0.5mm. The vertical position of the latch hook should be adjusted so that the door sensing switch, secondary interlock switch and third door are activated with the door closed. The horizontal position of the latch hook should be adjusted so that the monitor switch is activated with the door closed.
7. Secure the screws with washers firmly.
8. Check all of the switches operation. If any switch has not activated with the door closed, loosen screw and adjust the latch hook position.

#### **After adjustment, check the following.**

1. In and out play of door remains less than 0.5mm when in the latched position. First check upper position of latch hook, pushing and pulling upper portion of door toward the oven face. Then check lower portion of the latch hook, pushing and pulling lower portion of the door toward the oven face. Both results (play in the door) should be less than 0.5mm.
2. The door sensing switch, third door switch and secondary interlock switch interrupt the circuit before the door can be opened.
3. Monitor switch contacts close when door is opened.
4. The contact of door sensing switch and secondary interlock switch open within 1.2mm gap between right side of cavity face plate and door when door is open.
5. Re-install outer case and check for microwave leakage around door with an approved microwave survey meter. (Refer to Microwave Measurement Procedure.)

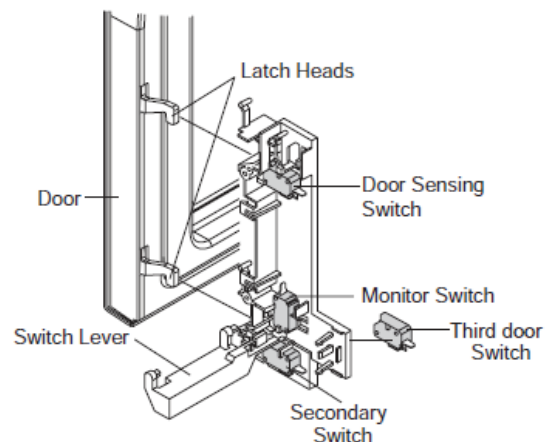

**Figure C-1. Latch Switch Adjustments**

## DOOR REPLACEMENT

### DOOR ASSEMBLY REMOVAL

1. Disconnect the power supply cord.
2. Open the door and block it open.
3. To discharge the high voltage capacitor, wait for 60 seconds.
4. Remove the two (2) screws holding the hood exhaust louver to the oven cavity front face plate.
5. Remove the hood exhaust louver from the oven cavity by pushing the right and left tabs of the hood exhaust louver. (Refer to the procedure of "HOOD EXHAUST LOUVER REMOVAL".)
6. Insert a putty knife (thickness of about 0.5mm) into the gap A between the door stopper and the choke cover as shown in Figure C-3 to free engaging parts.
7. Lift up the door stopper.
8. Now, the door stopper is free from the door assembly.
9. Lift up the door assembly to release the upper and lower door hinge pins from the upper and lower oven hinges.
10. Now, the door assembly is free.

**Note:** When the individual parts are replaced, refer to "Door Disassembly".

### DOOR ASSEMBLY RE-INSTALL

1. On re-installing door, insert the lower oven hinge to lower door hinge pin.
2. Insert the upper oven hinge to the upper door hinge pin.
3. Shut the door (close the contacts of interlock switches).
4. Make sure upper and lower oven hinges are inserted into the upper and lower door hinge pins.
5. Make sure the door is parallel with oven face lines (left and upper side lines) and door latch heads pass through latch holes correctly.
6. Re-install the door stopper to the door assembly.

7. Re-install the hood exhaust louver to the oven cavity front face plate with the two (2) screws.

**Note:** After any service to the door;

(A) *Make sure that door sensing switch and primary interlock switch are operating properly. (Refer to chapter "Test Procedures".)*

(B) *An approved microwave survey meter should be used to assure compliance with proper microwave radiation emission limitation standards.*

**After any servicing, make sure of the following :**

1. Door latch heads smoothly catch latch hook through latch holes and that latch head goes through center of latch hole.
2. Deviation of door alignment from horizontal line of cavity face plate is to be less than 1.0mm.
3. Door is positioned with its face pressed toward cavity face plate.
4. Re-install outer case and check for microwave leakage around door with an approved microwave survey meter. (Refer to Microwave Measurement Procedure.)

**Note:** *The door on a microwave oven is designed to act as an electronic seal preventing the leakage of microwave energy from oven cavity during cook cycle. This function does not require that door be air-tight, moisture (condensation)-tight or light-tight. Therefore, occasional appearance of moisture, light or sensing of gentle warm air movement around oven door is not abnormal and do not of themselves indicate a leakage of microwave energy from oven cavity.*



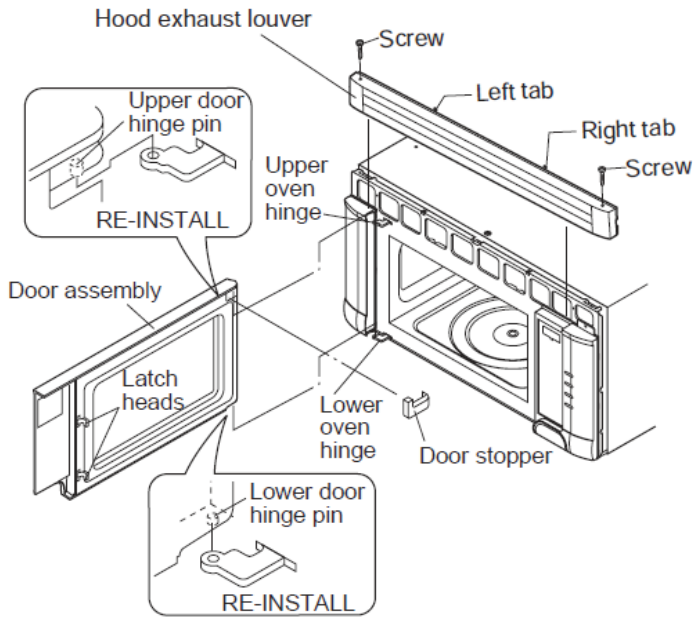

**Figure C-2. Door Replacement and adjustment**

## DOOR DISASSEMBLY

1. Disconnect the power supply cord.
2. Open the door and block it open.
3. To discharge the high voltage capacitor, wait for 60 seconds.
4. Remove the three (2) screws holding the hood exhaust louver to the oven cavity front face plate.
5. Remove the hood exhaust louver from the oven cavity. (Refer to the procedure of "HOOD EXHAUST LOUVER REMOVAL".)
6. Remove door assembly, referring to "DOOR REPLACEMENT INSTRUCTIONS"

**Replacement of door components are as follows:**

7. Place door assembly on a soft cloth with latches facing up.

*Note: As the engaging part of choke cover and door frame are provided at 15 places, do not force any particular part.*

## CHOKE COVER

8. Insert a putty knife (thickness of about 0.5mm) into the gap A between the choke cover and door stopper and between the

choke cover and the door frame as shown Figure C-3 to free engaging parts.

9. Pry the choke cover by inserting a putty knife in order shown in Figure C-3.
10. Now choke cover is free from door panel and door frame.

*NOTE: When carrying out any repair to the door, do not bend or warp the slit choke (tabs on the door panel assembly) to prevent microwave leakage.*

## DOOR FRAME ASSEMBLY

11. Remove two (2) screws holding the door panel to the door frame assembly.
12. Release the door panel from the door frame assembly. NOTE: It is easier to release the engaging parts of the upper or lower door hinge pin side at first.
13. Now, door frame assembly is free.

## LATCH SPRING, LATCH HEAD AND DOOR PANEL

14. Release the latch spring from the tab of the latch head and tab of the door frame.
15. Release the latch head from the door frame.
16. Now, the latch spring and latch head are free.

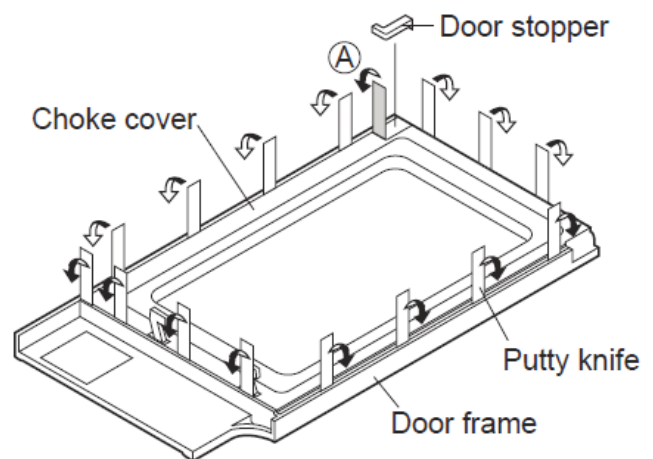

**Figure C-3. Door Disassembly**

## NOISE FILTER REMOVAL

1. Disconnect the power supply cord and then remove the outer case.
2. Open the door and block it.
3. Discharge the high voltage capacitor.
4. Disconnect the wire leads from the terminals of the noise filter.
5. Remove one screw mounted into the noise filter and fan duct.
6. The noise filter is now free.



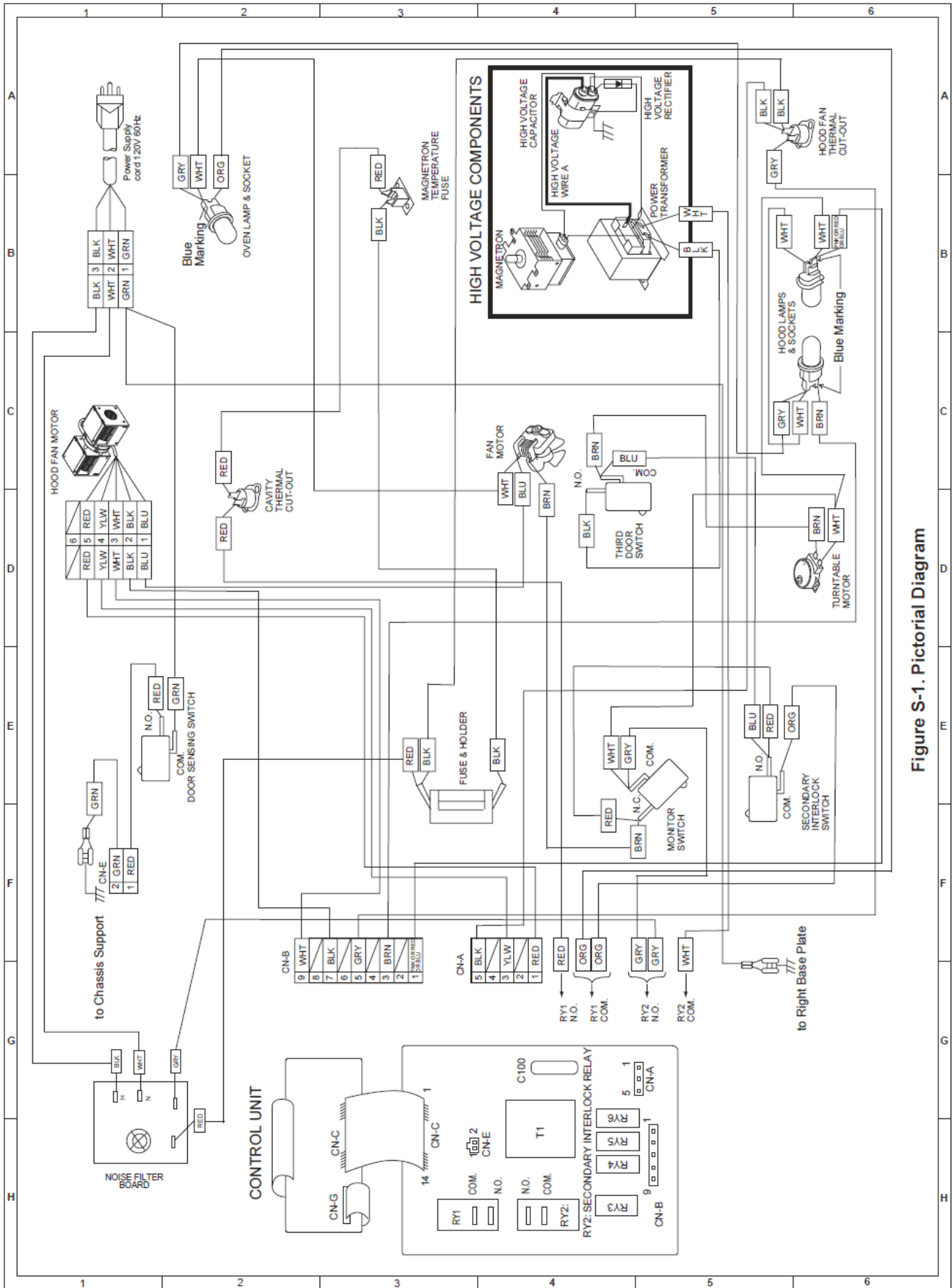

Figure S-1. Pictorial Diagram