



Fast Track Troubleshooting

Models:
DV520AEP DV520AGP
DV520AEW DV520AGW

IMPORTANT SAFETY NOTICE – “For Technicians Only” This service data sheet is intended for use by persons having electrical, electronic, and mechanical experience and knowledge at a level generally considered acceptable in the appliance repair trade. Any attempt to repair a major appliance may result in personal injury and property damage. The manufacturer or seller cannot be responsible, nor assume any liability for injury or damage of any kind arising from the use of this data sheet.

NOTICE: 8/1/11 Parts changes see bulletins for serial breaks: motor, motor relay, wiring harness, & main PCB
All Dryers Parts Change 6/2010: Motor Pulley, page 5;
Blower Housing, page 4

Publication # tsDV520 Revision Date 08/3/2011

Error Display	Trigger	Action Taken
ERROR! Temperature Sensor Problem	The Thermistor resistance is very low or high.	Check for : - Clogged lint screen - Restricted vent system. - Check Thermistor resistance.
ERROR! Door is open.	Running the dryer With door open	Check for : - Close the door, and run the dryer - Loose or open wire terminals in Door sense circuit.
ERROR! Door Open Sensing Problem	Invalid state for More than 256 Milliseconds	Check for : - Loose or open wire terminals in Door sense circuit.
ERROR! A Button is either stuck or is being pressed continuously.	Invalid state of Key circuit short for 75secs	Check for : - Display PCB key circuit short or not
ERROR! Time Limit Exceeded	Invalid Dry time in excess Dry time	Check for : - Sensor bar Open - Using Adjust time Up excessively
ERROR! Overheated	Invalid heating Temp in running the dryer	Check for : - Restricted vent system. - Check Thermistor resistance.
ERROR! Electronic Control Problem	Invalid state of Eeprom communication	Check for : - PCB on Eeprom circuit
ERROR! Power Interruption	Invalid power source Frequency	Check for : -Not using regular power source frequency - Invalid power frequency sense circuit

SUPPORT INFORMATION

Training — Plus One
<http://my.plus1solutions.net/clientPortals/samsung/>
 Help — GSPN <http://service.samsungportal.com/>
 Samsung Product Support TV
<http://support-us.samsung.com/spstv/howto.jsp>
 Customer information videos and chat programs
 Programs for Fridges, Laundry, Ranges & D/W

Electrical Dryers 240 VAC, 60 Hz, 30 Amps, 3-wire or 4-wire installations

Gas Dryers 120 VAC, 60 Hz, 15 Amps, 3-wire installations

Location consideration In the USA

- All Dryers Must be vented to the outside.
- Only rigid or flexible metal duct should be used for venting.

GAS DRYER WIRING DIAGRAM

SUB DISPLAY

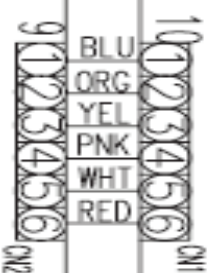

MAIN PCB CONTROL

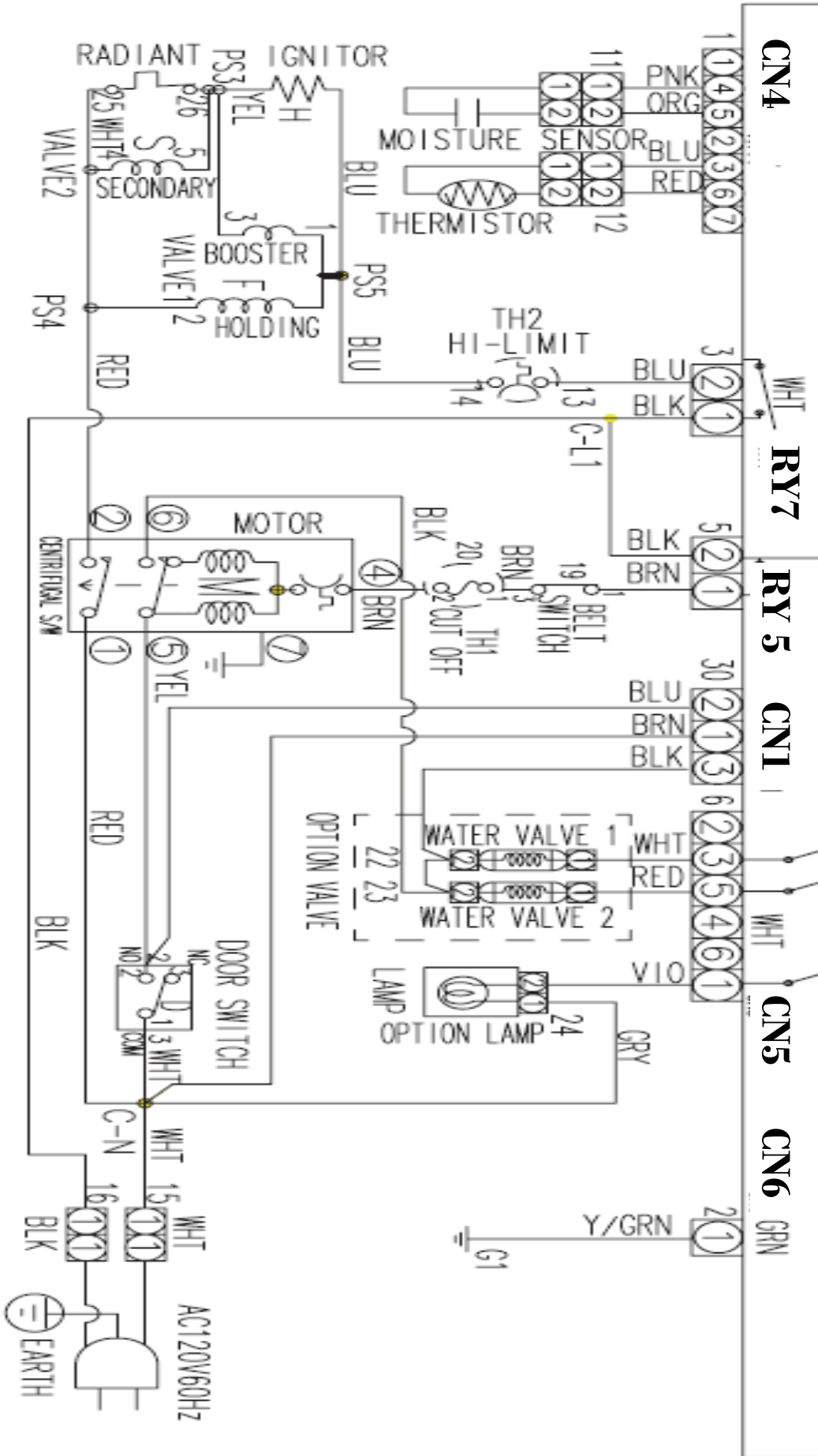

ELECTRIC DRYER WIRING DIAGRAM

SUB DISPLAY

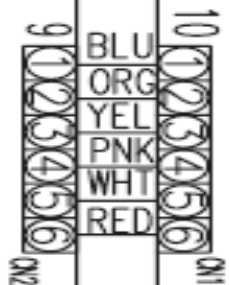

MAIN PCB

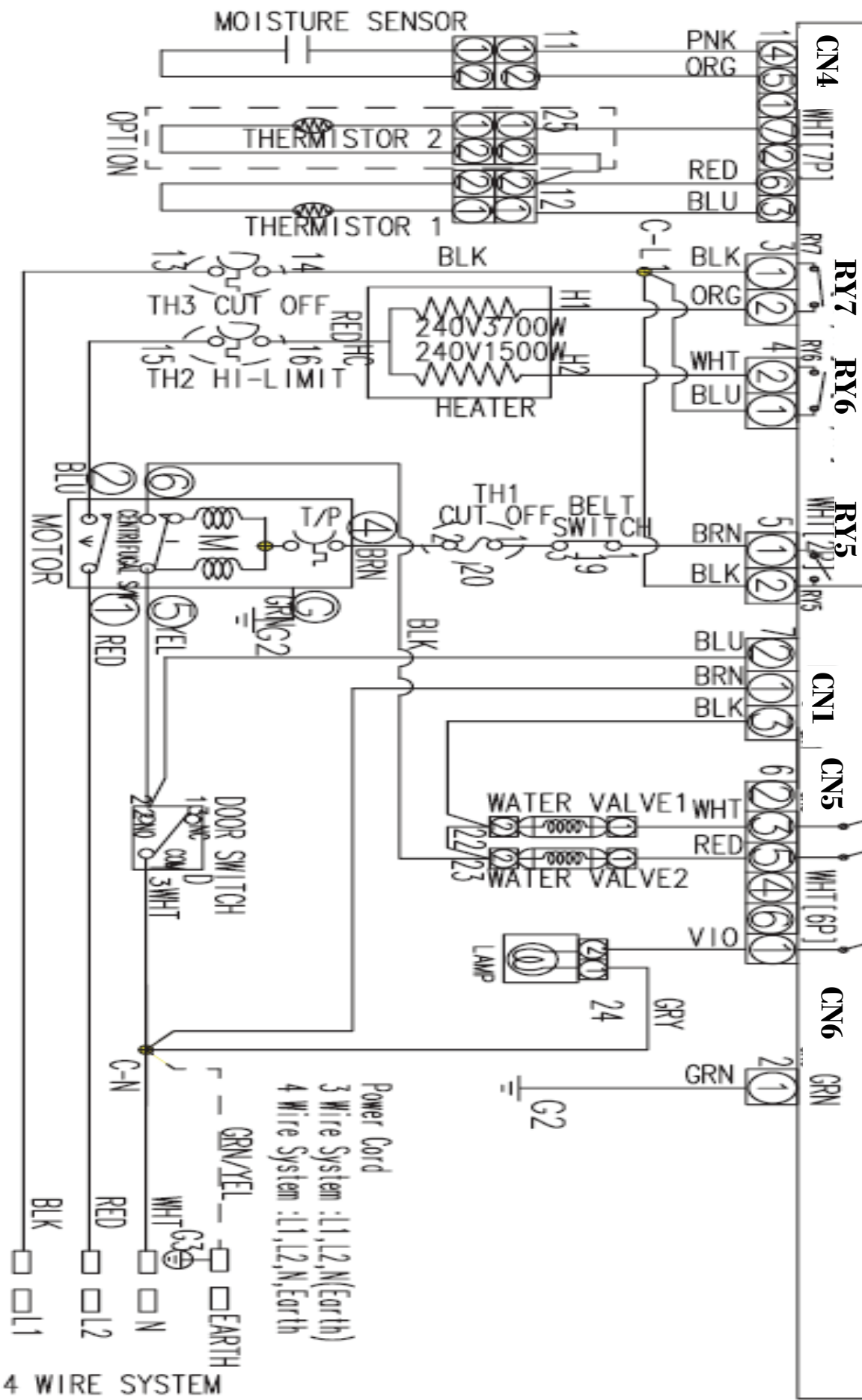

Power Cord
 3 Wire System : L1, L2, N (Earth)
 4 Wire System : L1, L2, N, Earth

4 WIRE SYSTEM

CN1
 1 120vac N (Brn)
 2 AC Pwr Off Detection (Blu)
 3 Door Detection (Blk)

CN5
 1 Lamp (Vio)
 3 Water Valve (Wht)
 5 Water Valve (Red)

CN2 Sub PCB Display
 5-4 5VDC (Wht-Pnk)
 6-4 12VDC (Red-Pnk)

CN4
 3-6 Thermistor 1 (Blu-Red)
 4-5 Moisture Sensor (Pnk-Org)



Relay 5
 1 Motor Belt Sw (Brn)
 2 120vac L1 (Blk)

Relay 7 (Gas Valve)
 1 120vac L1 (Blk)
 2 TH2 Hi Limit (Blu)

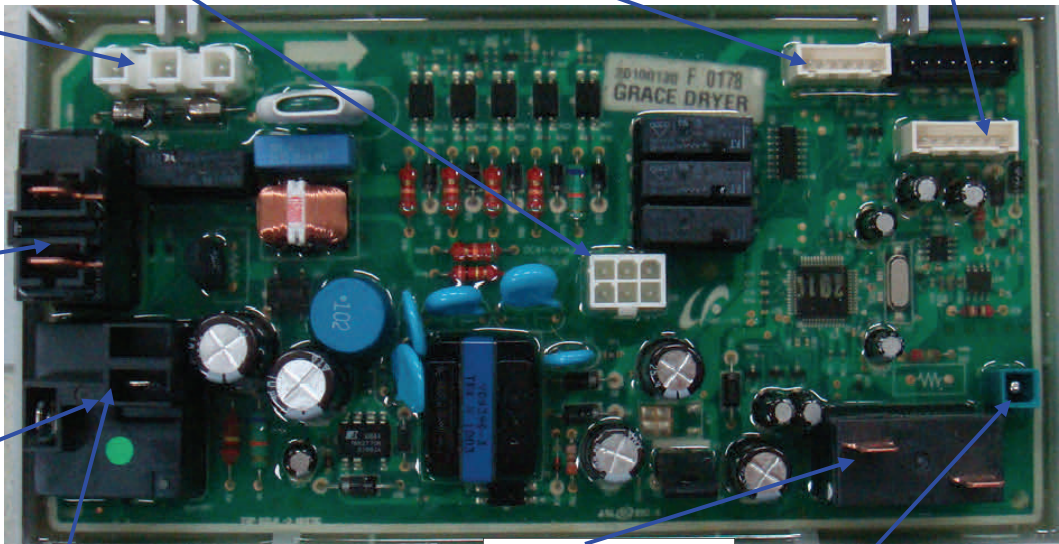

Relay 7 (Electric)
 1 120vac L1 (Blk)
 2 Heater 1 (Blu)

Relay 6 (Electric)
 1 120vac L1 (Blk)
 2 Heater 2 (Wht)

CN6
 1 Earth Ground (Grn)

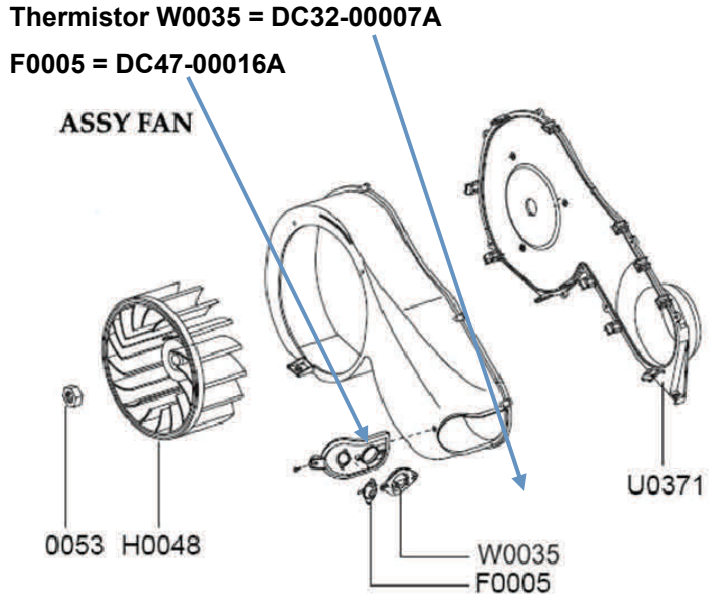
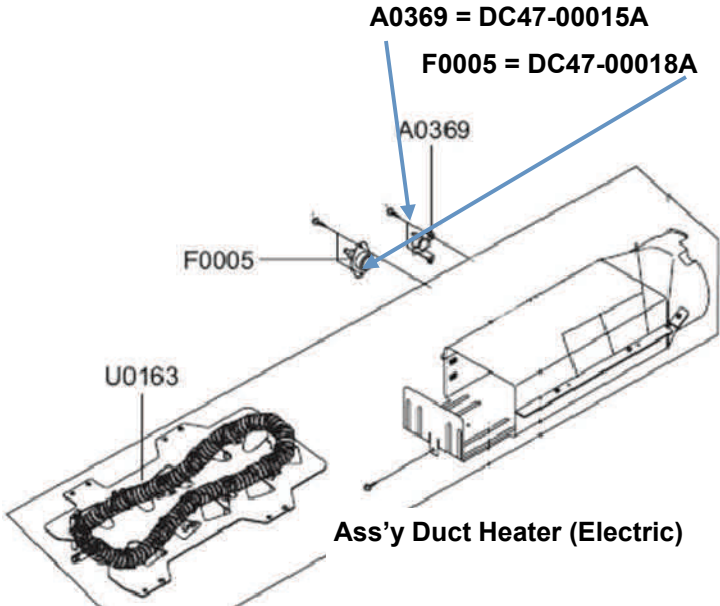
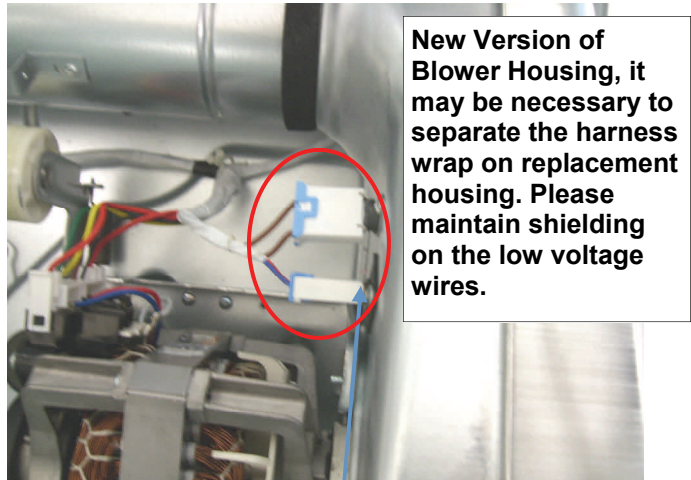
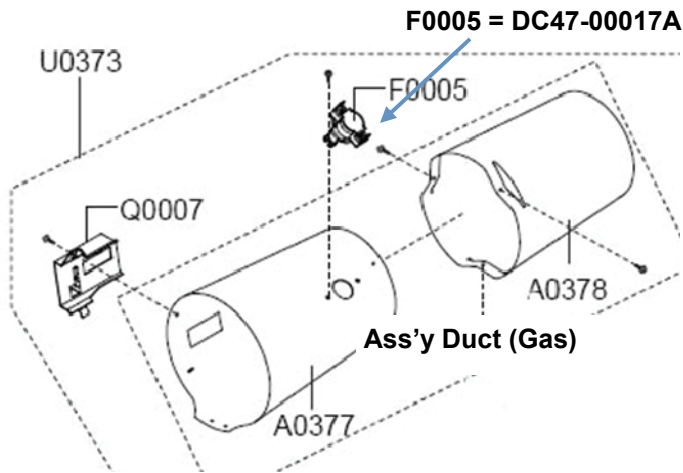

Gas Valve Testing

Unplug connectors and test valve terminals

(its numbering is from the front terminal.)

Check across terminals #1 and #3 (Booster Coil).	550 Ω
Check across terminals #1 and #2 (Holding Coil).	1350 Ω
Check across terminals #2 and #3 (Both coils in series).	1900 Ω
Check across terminals #4 and #5 (Secondary Coil).	1300 Ω

SUBJECT: Dryer belt slides off the pulley when manually rotated counter-clockwise (ccw)

SYMPTOM: The dryer drum will not turn. On occasions, the customer will rotate the drum counter clockwise (CCW) to check for any remaining clothes left in the dryer drum. By rotating the drum CCW, the idler arm may shift causing the belt to slide off the pulley.

SOLUTION: To prevent the dryer belt from sliding off the pulley, the pulley has been redesigned. The Outside Diameter has been changed from 22mm to 27mm.

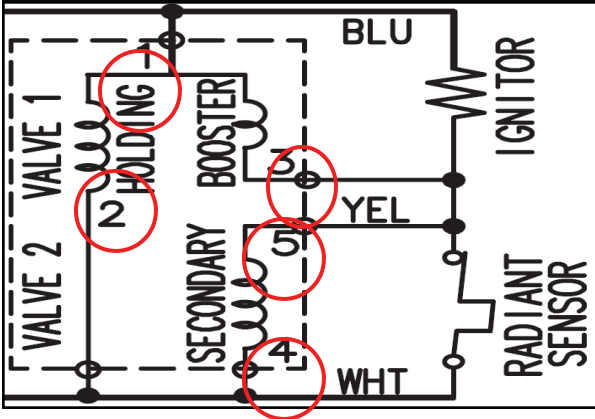

New
DC81-00220A

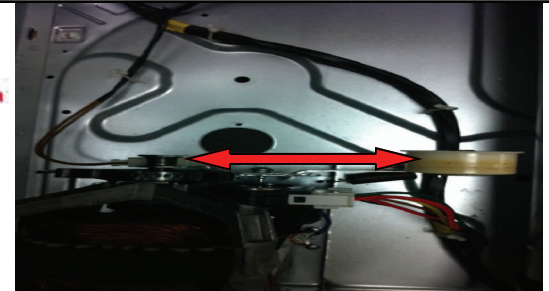

Make sure the motor pulley & the idler pulley are in a straight line

Cycle Count Test Mode

How to Enter: Press Temp + Mixed Load Bell Keys for 3 sec during Power On State.

Press Mixed Load Bell for 3 seconds (until beep)

Note: Test mode subject to change without notice

Sensor Bar Touch Data Mode

How to Enter:

Power on dryer, open door and press in door switch.

Start dryer tumbling. Press Temp + Mixed Load Bell for 3 sec.

Touch both sensor bars with wet cloth, sensor hit numbers show in display.

Note: Test mode subject to change without notice

Software Version Test Mode

How to Enter:

Press Temp + Mixed Load Bell Keys for 3 sec during Power On State.

Press Temp key for 3 seconds (until beep)

Note: Test mode subject to change without notice

Data Display Mode

How to Enter:

- With Power On, (unit can be running) press AdjustUp Key + AdjustDown Key for 7 seconds until it sends out a beeping sound .

- If not pressed any keys for 5 minutes, it will be set back from Data Display Mode

- If pressing AdjustUp Key in this mode ,Display Mode ID will be increased.

- If pressing AdjustDown Key in this mode ,Display Mode ID will be decreased.

Definition of Software Version Mode:

- Display Mode 0 : Temperature data in C

- Display Mode 1 : Average Touch Sensor data for 1 minute

- Display Mode 2 : Average Temperature data for minute

Dryer continues to run after cycle completed

Wrinkle Prevent option provides approximately 90 minutes (20 continuous and 70 intermittent) of tumbling in unheated air at the end of the cycle to reduce wrinkling. Press the Wrinkle Prevent button to activate or deactivate this feature. The indicator light above the pad will illuminate when Wrinkle Prevent is selected. Chasing lights appear in the display when the Wrinkle Prevent option is selected. The load is dry, and can be removed at any time during the Wrinkle Prevent cycle.

ELECTRIC AND GAS DRYER

Weather Hood Type

Recommended

Use only for short-run installation



4" (10.16 cm)

2.5" (6.35 cm)

No. of 90° elbows	Recommended		Use only for short-run installation	
	Rigid	Metallic Flexible*	Rigid	Metallic Flexible*
0	24.4 m (80 ft.)	12.4 m (41 ft.)	22.6 m (74 ft.)	10.1 m (33 ft.)
1	20.7 m (68 ft.)	11.2 m (37 ft.)	18.9 m (62 ft.)	8.8 m (29 ft.)
2	17.4 m (57 ft.)	10.1 m (33 ft.)	15.5 m (51 ft.)	7.6 m (25 ft.)
3	14.3 m (47 ft.)	9.0 m (29 ft.)	12.5 m (41 ft.)	6.5 m (21 ft.)

* Do not use non-metallic flexible duct.

Testing Electric Heater circuit.

Disconnect White wire from RY6, turn power on, start dryer read voltage between RY6 Blue wire and CN6 Green wire.

Disconnect Orange wire from RY7, turn power on, start dryer read voltage between RY6 Blue wire and CN6 Green wire.

Reading of 120VAC means a proper operating heater circuit. 0VAC means open in circuit.

One heater reading 0vac means that heater is open.

To test thermostat use ohm meter on lowest scale, any resistance replace component

See page 4 for Main PCB layout for testing.

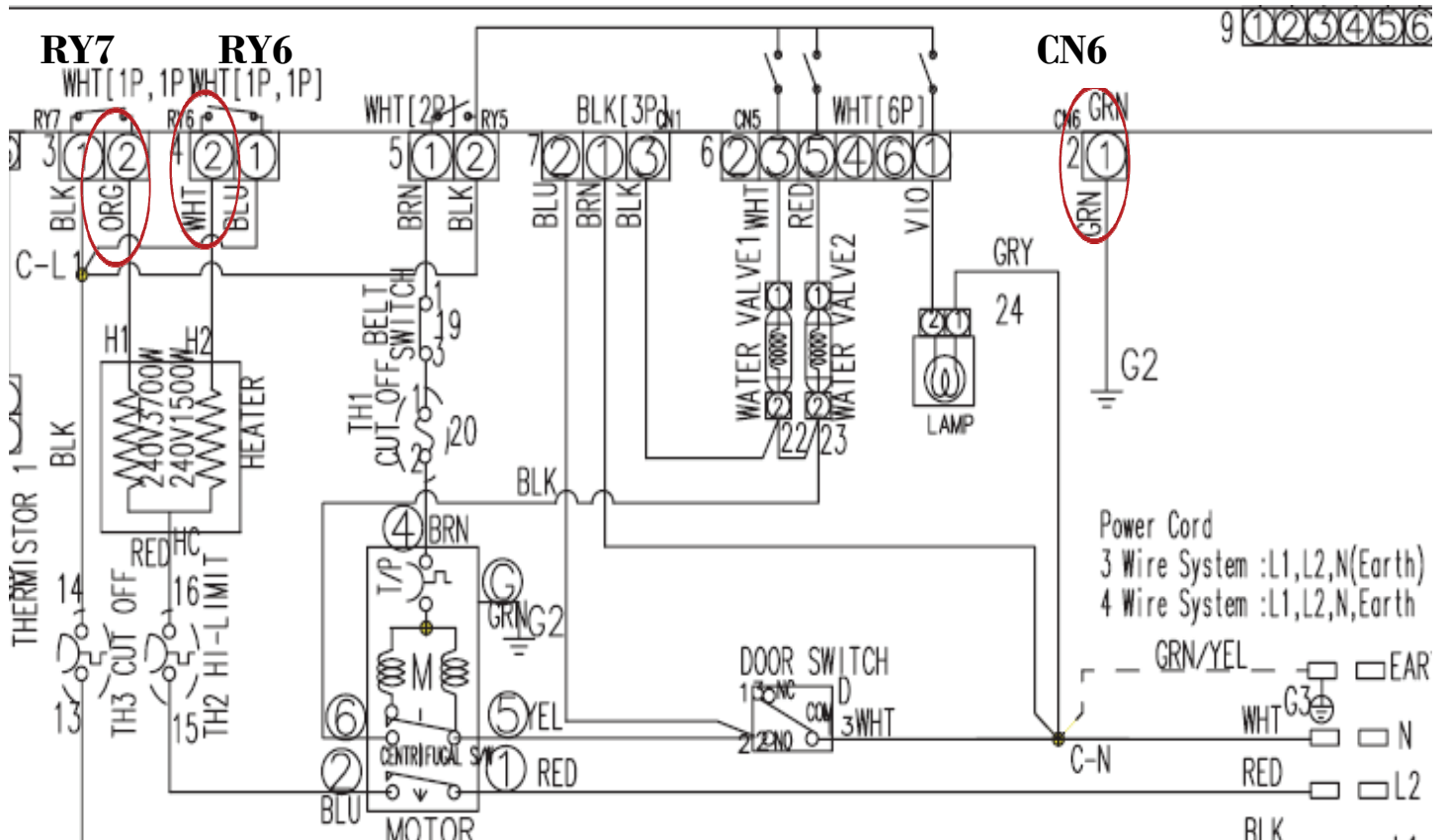

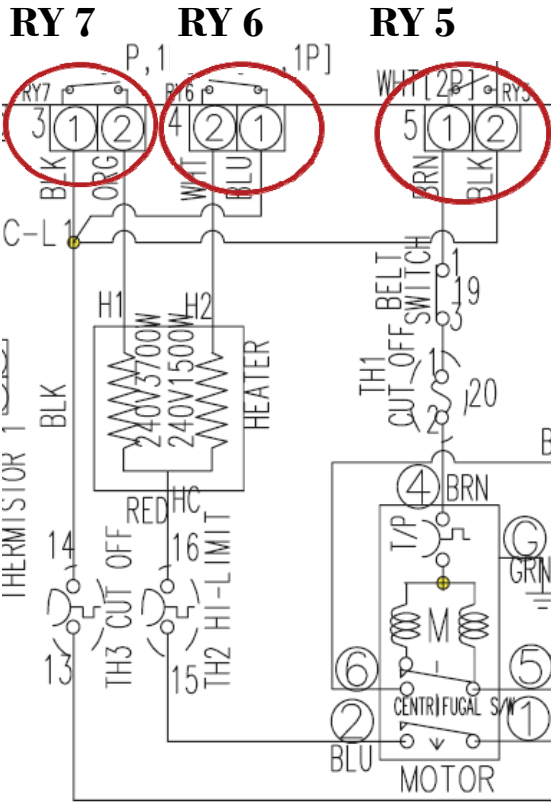

Testing Main PCB power output to Heating & Motor circuit.

With motor running in the heating mode, read AC voltage across RY7, RY6 and RY5.

Any voltage reading means Main PCB is defective.

See page 4 for Main PCB layout for testing.

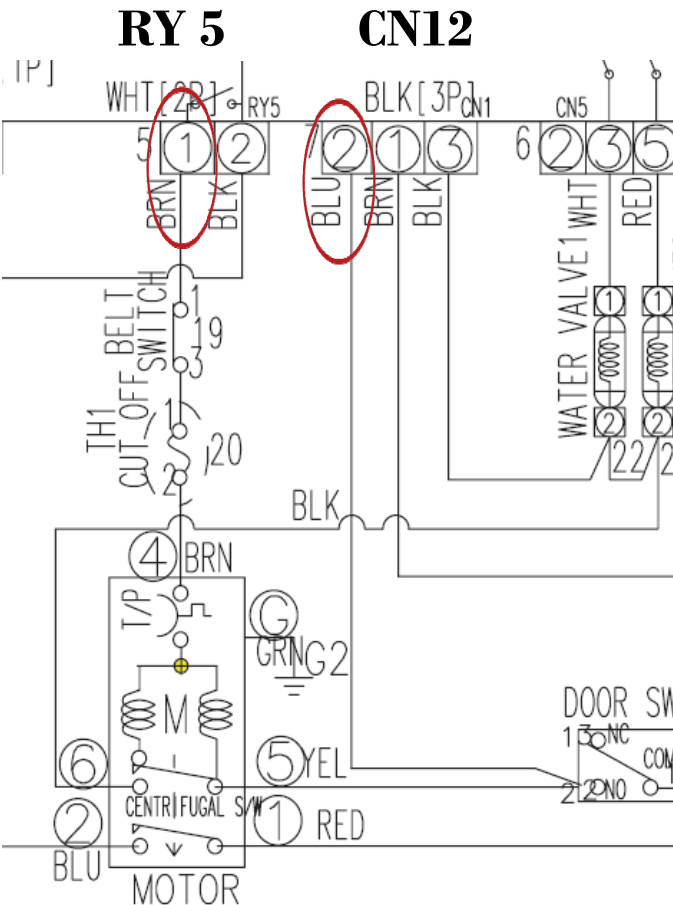

Testing Motor circuit.

With power off read resistance between RY5 Brown and CN1 Blue.

Resistance reading of good motor circuit is about 1.9Ω. To test thermostat and switch use ohm meter on lowest scale, any resistance replace component.

See page 4 for Main PCB layout for testing.

Do not use dryer to dry clothes which have traces of any flammable substance, such as vegetable oil, cooking oil, machine oil, flammable chemicals, thinner, etc., or anything containing wax or chemicals, such as mops and cleaning cloths. Flammable substances may cause fabric to catch fire by itself.