



Fast Track Troubleshooting



Models: DV203***
DV206* DV209*****
DV218* DV219*****
DV306* DV316*****
DV317* DV326*****
DV328* DV337*****
DV3C6***

IMPORTANT SAFETY NOTICE – “For Technicians Only” This service data sheet is intended for use by persons having electrical, electronic, and mechanical experience and knowledge at a level generally considered acceptable in the appliance repair trade. Any attempt to repair a major appliance may result in personal injury and property damage. The manufacturer or seller cannot be responsible, nor assume any liability for injury or damage of any kind arising from the use of this data sheet.

NOTICE: All Dryers
Parts Change 6/2010: Motor Pulley,
page 6; Blower Housing, page 4

Publication # tsDV203 Revision Date 06/27/2011

Samsung 'Dryer' Diagnostic Code Quick Guide

Display	Description	Trigger	Action Taken
	Dryer Thermistor Short Sensed	The Thermistor resistance is very low.	Check for: Clogged lint screen, Restricted vent system, Thermistor resistance.
	Dryer Thermistor Open Sensed	The Thermistor resistance is very high.	Check for: Clogged lint screen, Restricted vent system, Thermistor resistance.
do dE	Door Open	Running the dryer with door open	Check for: Loose or open wire terminals in Door Sense circuit.
FE	Power source frequency Error	Invalid power source Frequency	Check for: Non Utility power supply
dF	Door Circuit Failure	Invalid state for more than 256 milliseconds	Check for: Loose or open wire terminals in Door Sense circuit.
hE or HE	Heater Error	Invalid heating Temp in running the dryer	Check for: Restricted vent system, Thermistor resistance.
bE	Button Error	PCB key closed for 75 sec.	Check Display PCB for stuck button

SUPPORT INFORMATION

Training — Plus One

<http://my.plus1solutions.net/clientPortals/samsung/>

Help — GSPN <http://service.samsungportal.com/>

Samsung Product Support TV

<http://support-us.samsung.com/spstv/howto.jsp>

Customer information videos and chat programs

Programs for Fridges, Laundry, Ranges & D/W

Electrical Dryers 240 VAC, 60 Hz, 30 Amps, 3-wire or 4-wire installations

Gas Dryers 120 VAC, 60 Hz, 15 Amps, 3-wire installations

Location consideration In the USA:

- All Dryers Must be vented to the outside.
- Only rigid or flexible metal duct should be used for venting.

GAS DRYER WIRING DIAGRAM

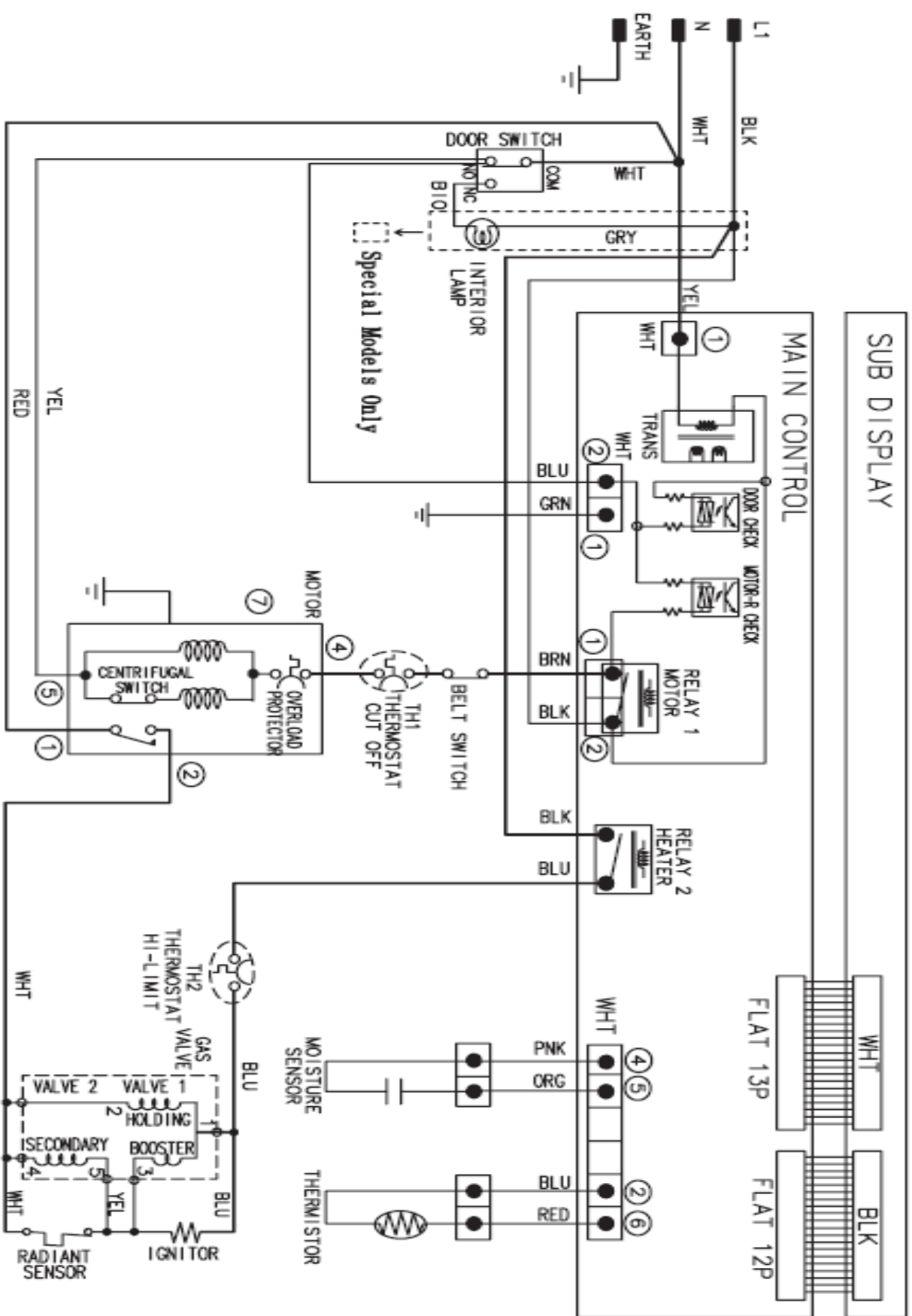

DC68-02319A

ELECTRIC DRYER WIRING DIAGRAM

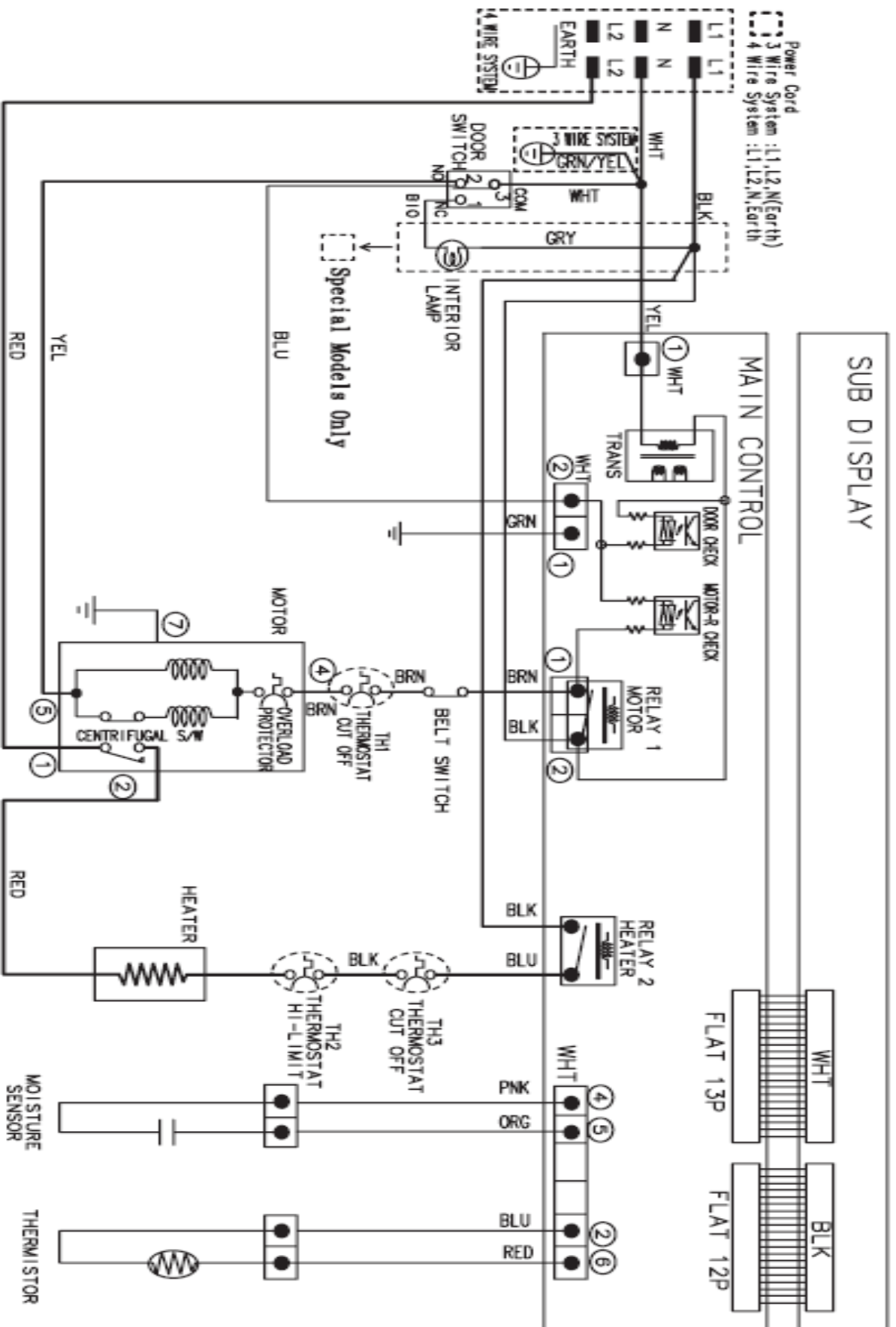

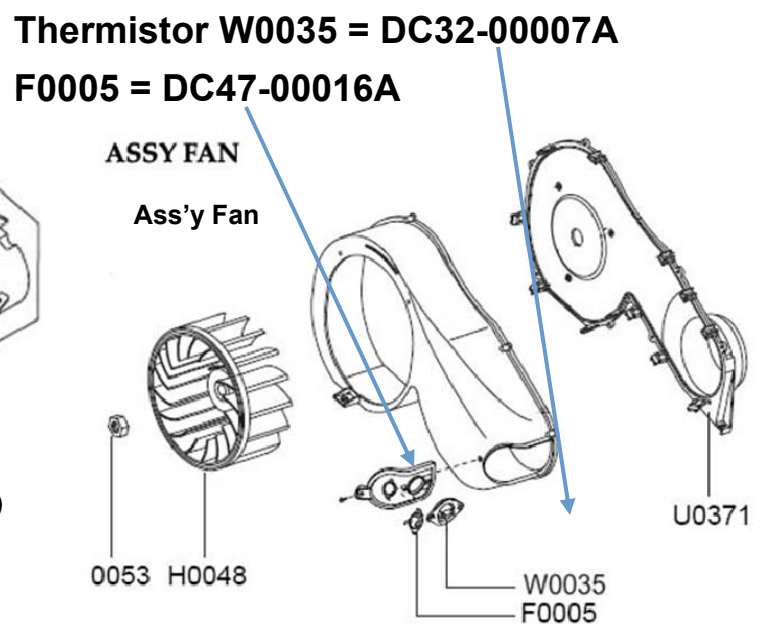
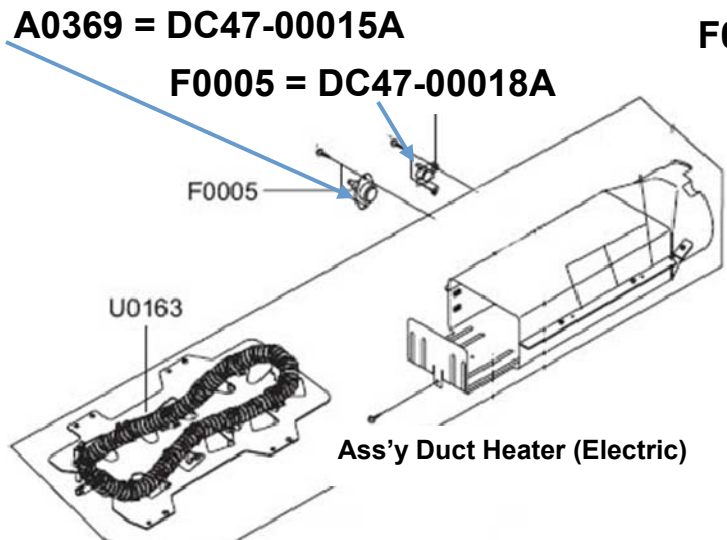
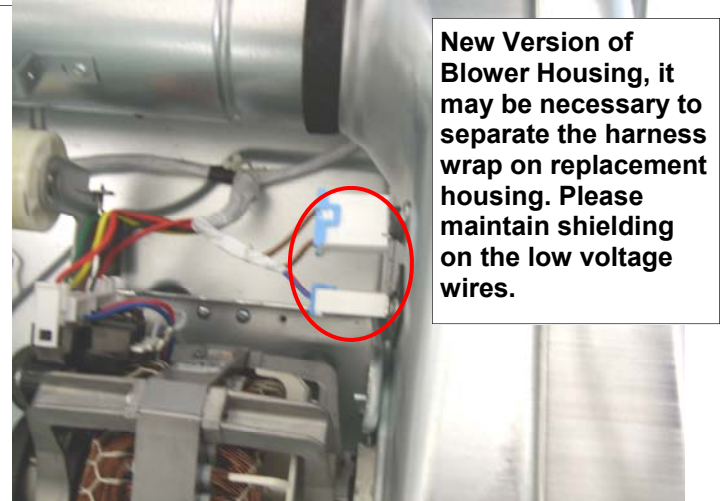
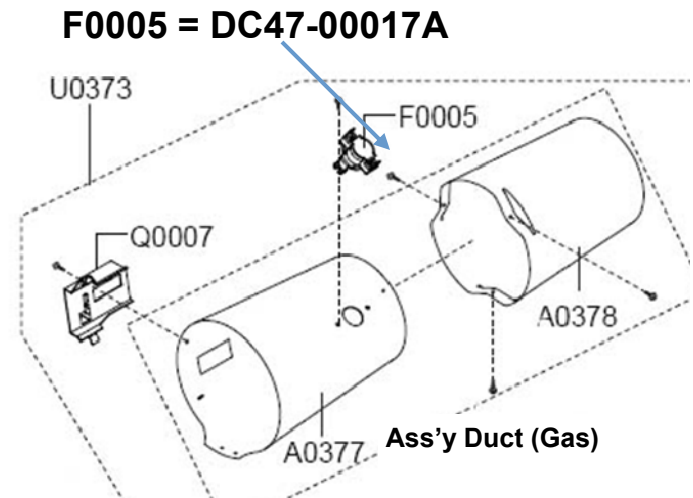
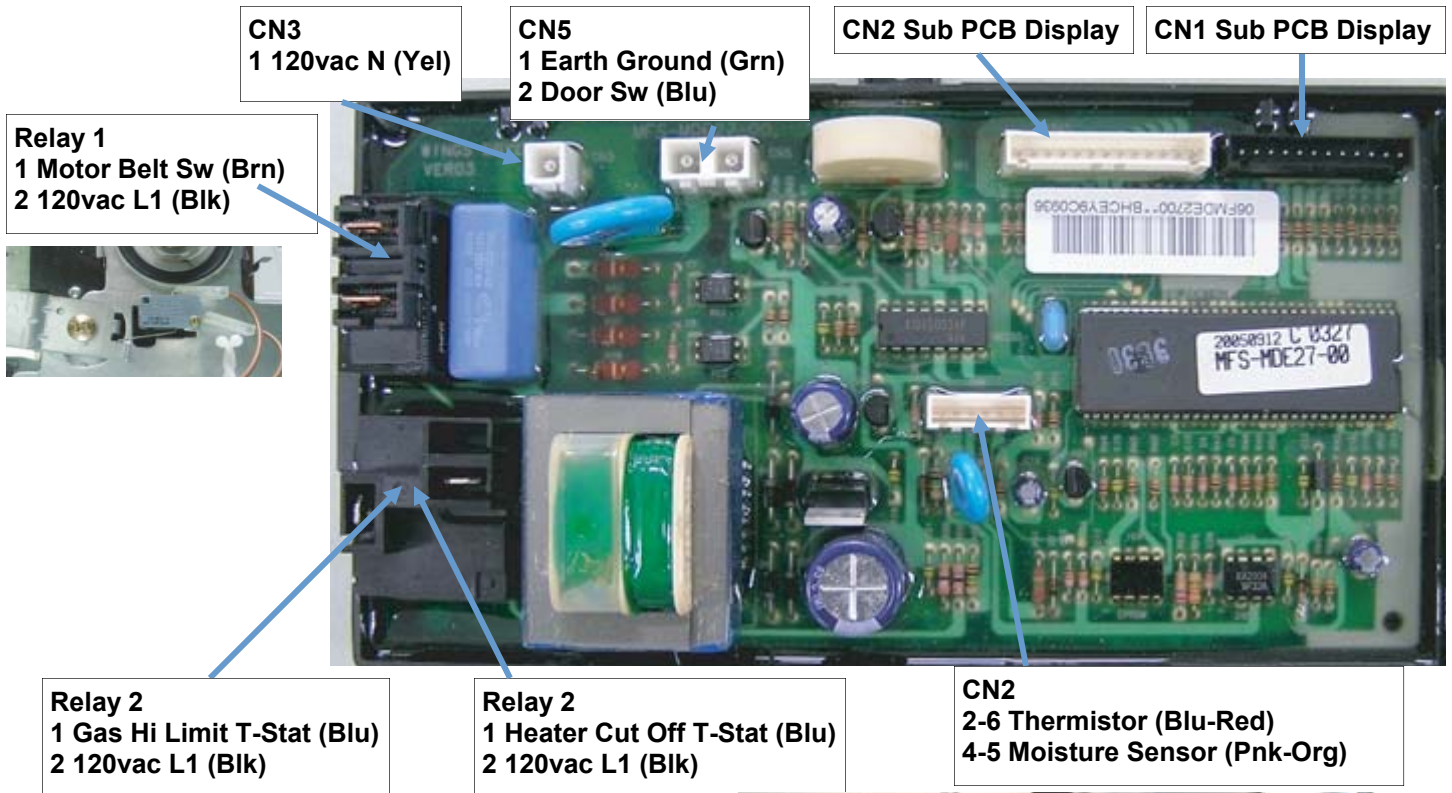

Gas Valve Testing

Unplug connectors and test valve terminals

(its numbering is from the front terminal.)

Check across terminals #1 and #3 (Booster Coil).	550 Ω
Check across terminals #1 and #2 (Holding Coil).	1350 Ω
Check across terminals #2 and #3 (Both coils in series).	1900 Ω
Check across terminals #4 and #5 (Secondary Coil).	1300 Ω

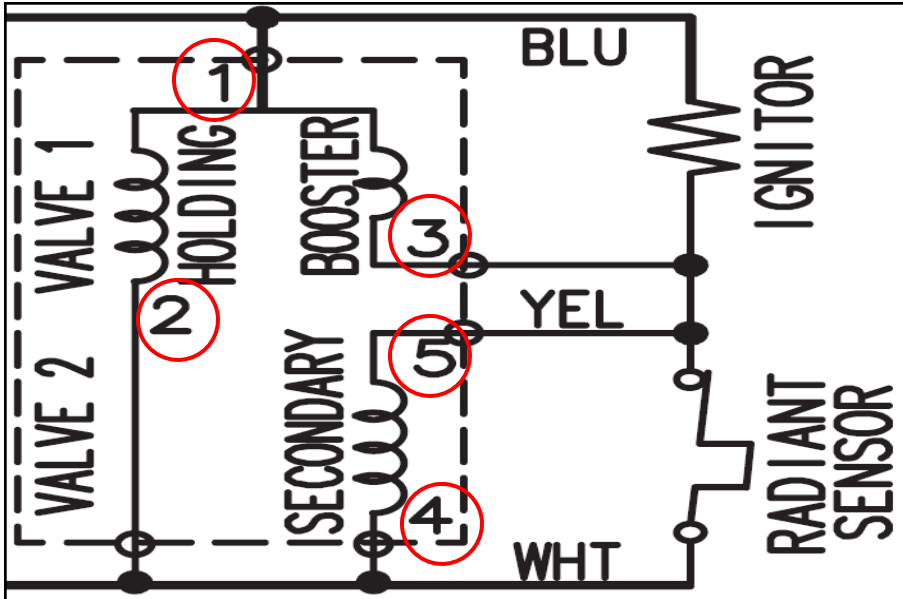

Thermistor

Temp F°	Ω
50	20KΩ
60	15.8KΩ
77	10KΩ
85	8KΩ
95	6.5KΩ
115	4.3KΩ
140	2.5KΩ
160	1.7KΩ
175	1.3KΩ
200	850Ω

Cycle Count Test Mode

How to Enter:

Press Signal + Wrinkle Prevent Keys for 3 sec during Power On State.

Press Signal key for 3 seconds (until beep)

Note: Test mode subject to change without notice

Sensor Bar Touch Data Mode

How to Enter:

Start Dryer tumbling, Press Temp + Signal for 3 seconds during the drying process.

Open door, touch both sensor bars with wet cloth, sensor hit numbers show in display.

Note: Test mode subject to change without notice

Temperature Test Diagnostic Mode

How to Enter:

Press Signal + Wrinkle Prevent Keys for 3 sec during Power On State.

Press Time + Wrinkle Prevent Keys and 7-segment will display the temperature in Celsius.

Compare vent temp to drum temp to see air flow.

Software Version Test Mode

How to Enter:

Press Signal + Wrinkle Prevent Keys for 3 sec during Power On State.

Press Temp key for 3 seconds (until beep)

Note: Test mode subject to change without notice

Special Test Mode:

- While in Power Off, pressing the Dryness Level + Power keys simultaneously will put the dryer into the System Check mode
- "t2" will display.
- System Check Mode Progress
- t2 mode Function Performed Start/Pause Motor(CW) Relay On → Heater Relay On → Heater Relay Off → Motor (CW) Relay Off (Circulation)

Caution! Do not give it too much testing time. It will over-burden the Main PCB.

Dryer continues to run after cycle completed

Wrinkle Prevent option provides approximately 90 minutes (20 continuous and 70 intermittent) of tumbling in unheated air at the end of the cycle to reduce wrinkling. Press the Wrinkle Prevent button to activate or deactivate this feature. The indicator light above the pad will illuminate when Wrinkle Prevent is selected. Chasing lights appear in the display when the Wrinkle Prevent option is selected. The load is dry, and can be removed at any time during the Wrinkle Prevent cycle.

SUBJECT: Dryer belt slides off the pulley when manually rotated counter-clockwise (ccw)

SYMPTOM: The dryer drum will not turn. On occasions, the customer will rotate the drum counter clockwise (CCW) to check for any remaining clothes left in the dryer drum. By rotating the drum CCW, the idler arm may shift causing the belt to slide off the pulley.

SOLUTION: To prevent the dryer belt from sliding off the pulley, the pulley has been redesigned.

The Outside Diameter has been changed from 22mm to 27mm.

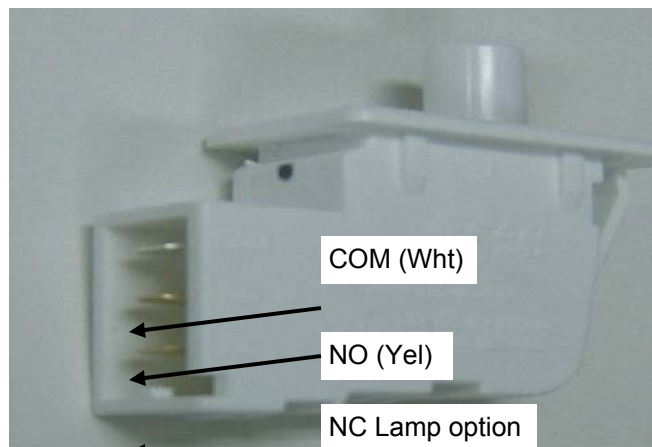

TOUCH UP PAINT, BLUE ONYX	DH81-11980A
TOUCH UP PAINT, IMPERIAL SILVER	DH81-11981A
TOUCH UP PAINT, NEAT WHITE	DH81-11982A
TOUCH UP PAINT, STRATUS GRAY	DH81-11983A
TOUCH UP PAINT, TANGO RED	DH81-11984A

In Addition to changing the new motor pulley you must also make sure the motor pulley & the idler pulley are in a straight line, if needed please bend them

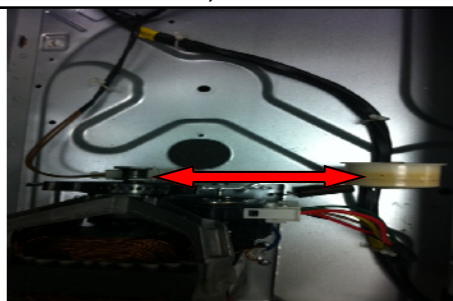

ELECTRIC AND GAS DRYER				
Weather Hood Type				
Recommended			Use only for short-run installation	
	 4" (10.16 cm)		 2.5" (6.35 cm)	
No. of 90° elbows	Rigid	Metallic Flexible*	Rigid	Metallic Flexible*
0	24.4 m (80 ft.)	12.4 m (41 ft.)	22.6 m (74 ft.)	10.1 m (33 ft.)
1	20.7 m (68 ft.)	11.2 m (37 ft.)	18.9 m (62 ft.)	8.8 m (29 ft.)
2	17.4 m (57 ft.)	10.1 m (33 ft.)	15.5 m (51 ft.)	7.6 m (25 ft.)
3	14.3 m (47 ft.)	9.0 m (29 ft.)	12.5 m (41 ft.)	6.5 m (21 ft.)

* Do not use non-metallic flexible duct.

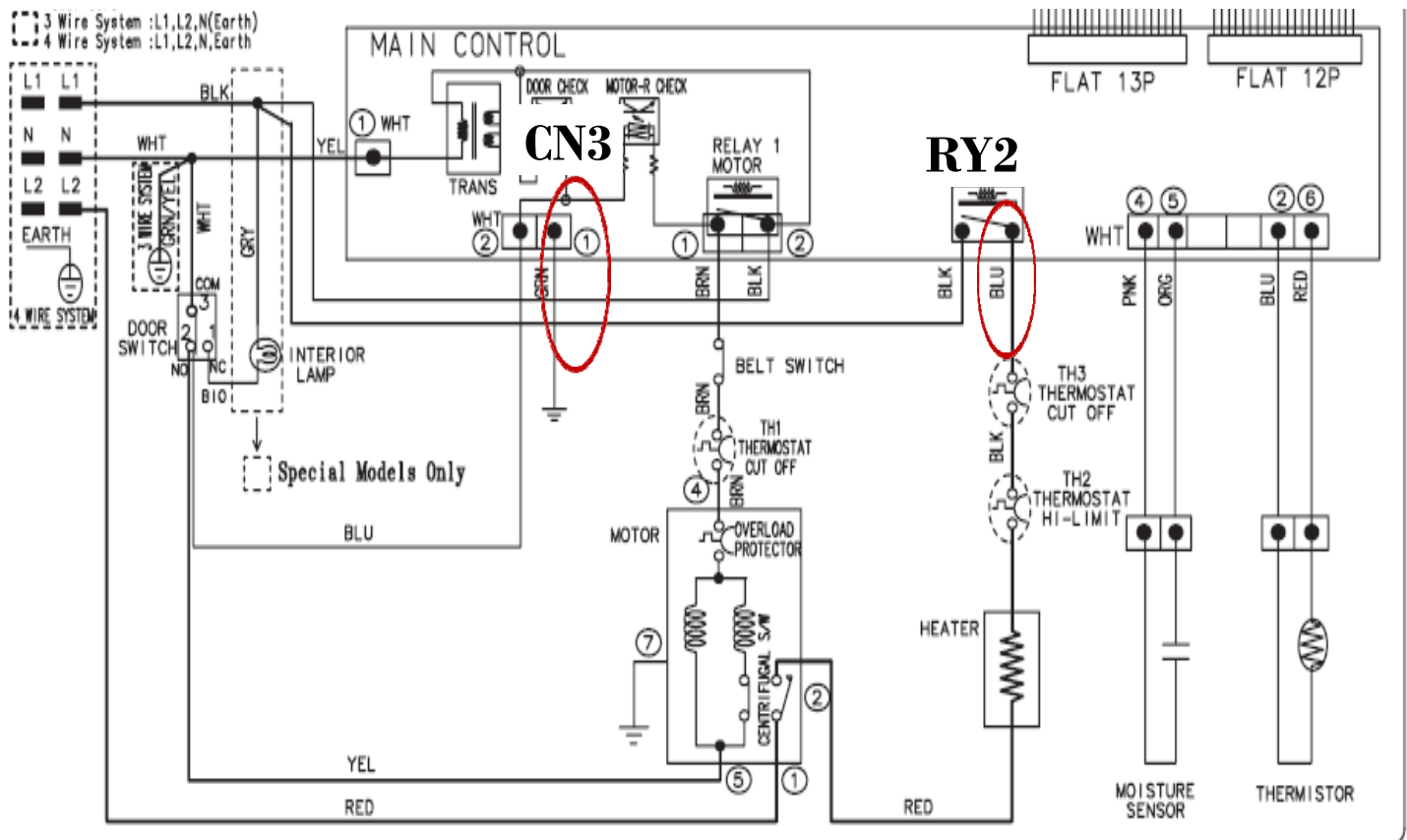

Testing Electric Heater circuit.

Disconnect Blue wire from RY2, turn power on, start dryer read voltage between RY2 Blue wire and CN3 Green wire.

Reading of 120VAC means a proper operating heater circuit. 0VAC means open in circuit.

To test thermostats use ohm meter on lowest scale, any resistance replace component

See page 4 for Main PCB layout for testing.

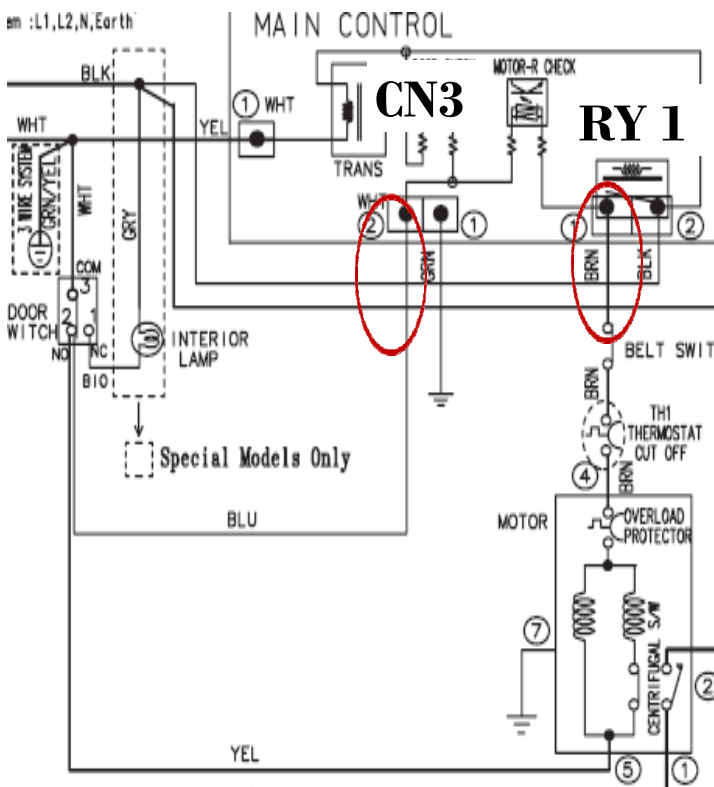

Testing Motor circuit.

With power off read resistance between RY1 Brown and CN3 Blue.

Resistance reading of good motor circuit is about 1.9Ω. To test thermostat and switch use ohm meter on lowest scale, any resistance replace component.

See page 4 for Main PCB layout for testing.

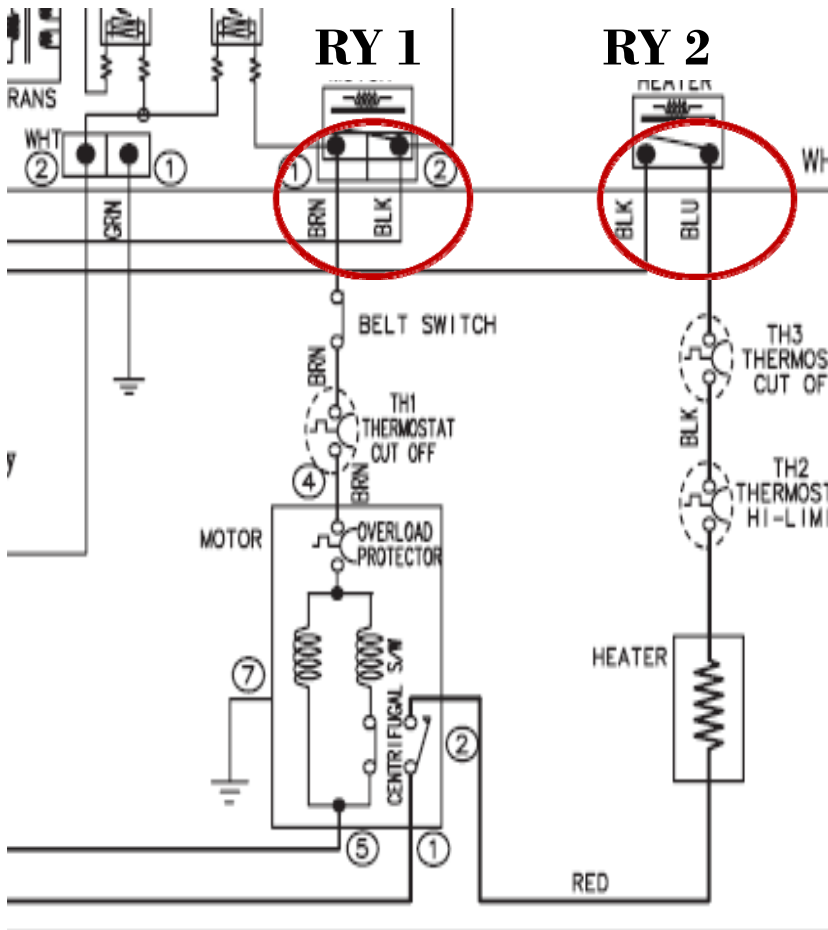

Testing Main PCB power output to Heating & Motor circuit.

With motor running in the heating mode, read AC voltage across RY1 and RY2.

Any voltage reading means Main PCB is defective.

See page 4 for Main PCB layout for testing.