



**CONSUMER SERVICES TECHNICAL
EDUCATION GROUP PRESENTS**

KM-27

MICROWAVE OVEN HOOD COMBINATION



**JOB AID
Part No. 8178053**

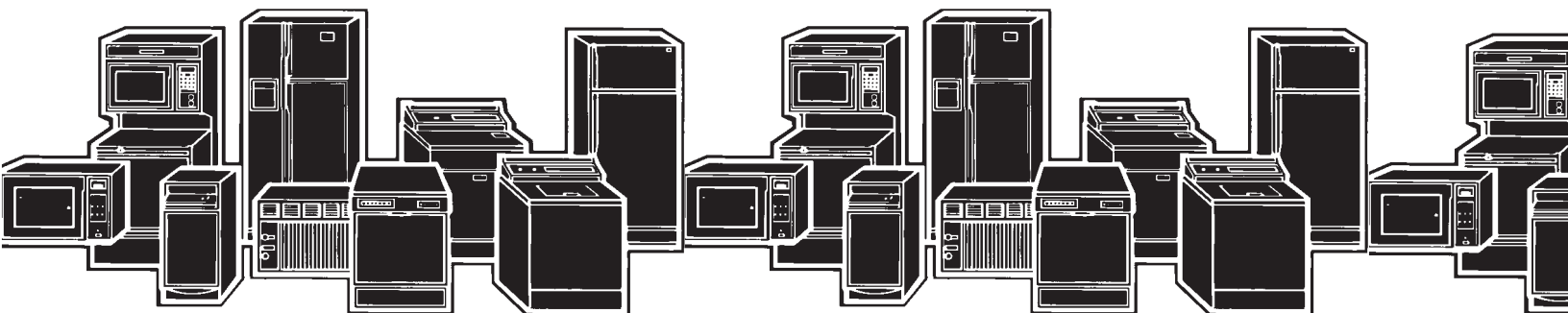

FORWARD

This Job Aid, "Whirlpool Microwave Oven Hood Combination," (Part No.8178053), provides the technician with information on the operation and service of the Whirlpool Microwave Oven Hood Combination. It is to be used as a training Job Aid and Service Manual. For specific information on the model being serviced, refer to the "Use and Care Guide," or "Tech Sheet" provided with the microwave oven.

The Wiring Diagrams and Strip Circuits used in this Job Aid are typical and should be used for training purposes only. Always use the Wiring Diagram supplied with the product when servicing the unit.

GOALS AND OBJECTIVES

The goal of this Job Aid is to provide detailed information that will enable the service technician to properly diagnose malfunctions and repair the Microwave Oven Hood Combination.

The objectives of this Job Aid are to:

- Understand and follow proper safety precautions.
- Successfully troubleshoot and diagnose malfunctions.
- Successfully perform necessary repairs.
- Successfully return the microwave oven to proper operational status.

WHIRLPOOL CORPORATION assumes no responsibility for any repairs made on our products by anyone other than Authorized Factory Service Technicians.

TABLE OF CONTENTS

	Page
GENERAL	1-1
Important Safety Information	1-1
Warning To Service Technicians	1-2
Precautions To Be Observed Before And During Servicing To Avoid Possible Exposure To Excessive Microwave Energy	1-3
R.F. Leakage Test	1-4
Whirlpool Model & Serial Number Designations	1-5
Model & Serial Number Label And Tech Sheet Locations	1-6
Specifications	1-7
Whirlpool Microwave Oven Warranty	1-11
THEORY OF OPERATION	2-1
The Vent Motor Mounting Positions	2-1
The Oven Thermostat & Vent Motor Capacitor	2-2
The Vent & Turntable Motors	2-3
COMPONENT ACCESS	3-1
Component Locations	3-1
Removing The Turntable Motor & Cooktop Lamp Assembly	3-2
Removing The Control Panel & Control Board	3-4
Removing The Door Switches	3-6
Removing The Oven Lamp Assembly	3-7
Removing The Oven Thermostat, Line Fuse, & Power Cord	3-8
Removing The Vent Motor Capacitor, The High Voltage Capacitor, & Rectifier	3-10
Removing The High Voltage Transformer	3-11
Removing The Magnetron	3-12
Removing The Vent Motor	3-13
Removing The Oven Door, The Switch Actuators, And The Outer Glass	3-14
COMPONENT TESTING	4-1
Touch Panel Continuity	4-1
The Turntable & Vent Motors	4-2
The Vent Motor Capacitor, Line Fuse, Oven Thermostat, & Door Switch	4-3
The High Voltage Capacitor & Rectifier	4-4
The High Voltage Transformer	4-5
The Magnetron	4-6
WIRING DIAGRAM & STRIP CIRCUITS	5-1
Wiring Diagram	5-1
Strip Circuits	5-2

— NOTES —

GENERAL

IMPORTANT SAFETY INFORMATION

Your safety and the safety of others is very important.

Important safety messages have been provided in this Job Aid. Always read and obey all safety messages.



This is the safety alert symbol. This symbol alerts you to hazards that can kill or hurt you and others.

All safety messages will be preceded by the safety alert symbol and the word **“WARNING.”**

All safety messages will identify the hazard, tell you how to reduce the chance of injury, and tell you what can happen if the instructions are not followed.

WARNING

ELECTRICAL SHOCK HAZARD

Disconnect power before servicing.
Replace all panels before operating.
Failure to do so could result in death or electrical shock.

IMPORTANT SAFETY INSTRUCTIONS

Before touching any oven component or wiring, always unplug the oven from its power source and discharge the capacitor by using a 20,000 ohm discharge resistor or use an insulated plastic handle screwdriver to short across the capacitor terminals.

Check that the unit is grounded before troubleshooting. Be careful of the high voltage circuits. Discharge any static charge from your body by touching ground before handling any part of the circuitry on the control board. Electrostatic discharge may damage the control circuit.

Do not touch oven components or wiring during operation. Attach meter leads with alligator clips when making operational tests.

For continued protection against radiation emission, replace only with these types of switches: Primary (Interlock) Switch: SZM-V16-FA-63 or VP-533A-OF; Secondary (Interlock) Switch: SZM-V01-FA-32; Interlock (Monitor) Switch: SZM-VI6-FA-62 or VP-532A-OF; Oven Lamp Switch: SZM-V6-FA-31 or VP-331 A-OD.

It is neither necessary nor advisable to attempt measurement of high voltage.

Attaching the adaptor ground terminal to the wall receptacle cover screw does not ground the appliance unless the cover screw is metal and not insulated and the wall receptacle is grounded through the house wiring.

ELECTROSTATIC DISCHARGE (ESD) SENSITIVE ELECTRONICS

ESD problems are present everywhere. ESD may damage or weaken the electronic control assembly. The new control assembly may appear to work well after repair is finished, but failure may occur at a later date due to ESD stress.

- Use an antistatic wrist strap. Connect the wrist strap to a green ground connection point or unpainted metal in the appliance; or touch your finger repeatedly to a green ground connection point or unpainted metal in the appliance.
- Before removing the part from its package, touch the antistatic bag to a green ground connection point or unpainted metal in the appliance.
- Avoid touching electronic parts or terminal contacts. Handle the electronic control assembly by the edges only.
- When repackaging the failed electronic control assembly in an antistatic bag, observe the above instructions.

WARNING TO SERVICE TECHNICIANS

To avoid possible exposure to microwave radiation or energy, visually check the oven for damage to the door and door seal before operating any oven. Use a microwave survey meter to check the amount of leakage before servicing. In the event the R.F. leakage exceeds 4 mw/cm² at 5 cm, appropriate repair must be made before continuing to service the unit. Check interlock function by operating the door latch. The oven cook cycle should cut off before the door can be opened.

The door and latching assembly contains the radio frequency energy within the oven. The door is protected by three safety interlock switches. Do not attempt to defeat them.

Under no circumstances should you try to operate the oven with the door open.

- Proper operation of microwave ovens requires that the magnetron be properly assembled to the waveguide and cavity. Never operate the magnetron unless it is properly installed.
- Be sure the "RF" seal is not damaged and is assembled around the magnetron dome properly when installing the magnetron.
- Routine service safety procedures should be exercised at all times.
- Untrained personnel should not attempt service without a thorough review of test procedures and safety information contained in this Job Aid.

Whirlpool microwave ovens have a monitoring system designed to assure proper operation of the safety interlock systems.

The interlock monitor switch will immediately cause the oven fuse to blow if the door is opened and the primary door interlock switch and/or the secondary interlock switch contacts fail in a closed position.

CAUTION: Replace a blown fuse with a 20 ampere class H fuse only.

Test the upper and lower door interlock switches, cook relay and interlock monitor switch (middle switch) for proper operation as described in the component test procedures, before replacing the blown oven fuse.

Do not attempt to repair sticking contacts of any interlock switch, safety switch, or Cook (Latch) relay. The components must be replaced.

Any indication of sticking contacts during component tests requires replacement of that component to assure reliability of the safety interlock system.

If the fuse is blown, the Monitor, Primary, and Secondary interlock switches must be replaced. Be sure they are properly connected.

PRECAUTIONS TO BE OBSERVED BEFORE AND DURING SERVICING TO AVOID POSSIBLE EXPOSURE TO EXCESSIVE MICROWAVE ENERGY

- A. Do not operate or allow the oven to be operated with the door open.
- B. Make the following safety checks on all ovens to be serviced before activating the magnetron or other microwave source, and make repairs as necessary:
 - 1) Interlock Operation
 - 2) Proper Door Closing
 - 3) Seal and Sealing Surfaces (Arcing, Wear, and Other Damage)
 - 4) Damage to or Loosening of Hinges and Latches
 - 5) Evidence of Dropping or Abuse
- C. Before turning on the microwave power for any service test or inspection within the microwave generating components, check the magnetron, wave guide or transmission line, and cavity for proper alignment, integrity, and connections.
- D. Any defective or misadjusted components in the interlock, monitor, door seal, and microwave generation and transmission systems shall be repaired, replaced, or adjusted, using procedures described in this Job Aid, before the oven is released to the owner.
- E. A microwave leakage check to verify compliance with Federal Performance Standard should be performed on each oven prior to release to the owner.
- F. Do not attempt to operate the oven if the door glass is broken.

R.F. LEAKAGE TEST

EQUIPMENT

- Electromagnetic energy leakage monitor (NARDA 81 00B, HOLADAY H 1501).
- 275 ±15 ML glass beaker.

TEST

On every service call, checks for microwave energy emission must be made according to the following manner.

1. Remove the cooking rack from the oven cavity, if the microwave oven is so equipped.
2. Place a 275 ±15 ML (9.3 oz.) glass of water in the center of the oven bottom.
3. Select "HIGH" cook power, turn the microwave oven on, and test for R.F. leakage at the following locations:
 - a) Around the cabinet at the front.
 - b) Around the door.
 - c) Across the console panel.
 - d) Horizontally across the door.
 - e) Vertically across the door.
 - f) Diagonally across the door.
 - g) Across the air vents.
 - h) Across the rear air vent.
 - i) All lockseams.
 - j) Weld at bottom.
 - k) Bottom plate.
 - l) Oven feet.
4. The scan speed is one inch per second.

When checking for R.F. leakage, use an approved R.F. measuring device to assure less than 4 mw/cm² emission at 5 cm distance with a maximum scan rate of 2.54 cm/second, in compliance with U.S. Government Department of Health, Education and Welfare 21CFR1030, performance Standard for Microwave Ovens.

A properly operating door and seal assembly will normally register small emissions, but they must be no greater than 4 mw/cm² to allow for measurement uncertainty.

NOTE: Enter leakage readings in space BEFORE and AFTER on the service document.

All microwave ovens exceeding the emission level of 4 mw/cm² must be reported to Dept. of Service for microwave ovens immediately and the owner should be told not to use the microwave oven until it has been repaired completely.

If a microwave oven is found to operate with the door open, report to Dept. of Service, the manufacturer and CDRH* immediately. Also tell the owner not to use the oven.

The interlock monitor switch acts as the final safety switch protecting the customer from microwave radiation. If the interlock monitor switch operated to blow the fuse when the interlocks failed, you must replace all interlock switches with new ones, because the contacts of those interlock switches may be melted and welded together.

If safety interlock/monitor switch replacement, or adjustment, is required, you must reconnect the circuit, and perform a continuity check on the monitor circuit.

All repairs must be performed in such a manner that microwave energy emissions are minimal.

Address for CDRH is:

**Office of Compliance (HFZ-342) Center for
Devices and Radiological Health
2098 Gaither Road
Rockville, MD 20850**

* CDRH: Center for Devices and Radiological Health, Food and Drug Administration.

WHIRLPOOL MODEL & SERIAL NUMBER DESIGNATIONS

MODEL NUMBER

MODEL NUMBER		M	H	6	14	0	X	K	Q	0
INTERNATIONAL SALES IND. OR MARKETING CHANNEL IF PRESENT										
PRODUCT GROUP G = WHIRLPOOL GOLD M = MICROWAVE										
PRODUCT IDENTIFICATION B = BROWNER C = CONVECTION G = GRILL / CRISPER H = OTR HOOD COMBO K = KITS M = GOLD CONVECTION S = STIRRER FAN T = TURNTABLE										
MODEL VARIATIONS 0 - 9										
CUBIC FEET 04 = .4 CU. FT. 10 = 1.0 CU. FT. 06 = .6 CU. FT. 12 = 1.2 CU. FT. 07 = .7 CU. FT. 14 = 1.4 CU. FT. 08 = .8 CU. FT. 15 = 1.5 CU. FT. 09 = .9 CU. FT. 16 = 1.6 CU. FT.										
FEATURE LEVEL 0 = 30" KIT (IF KIT) 2 = 22" KIT (IF KIT) 4 = 24" KIT (IF KIT) 5 = SENSORED MODEL 7 = 27" KIT (IF KIT)										
FEATURE CODE C = CSA APPROVED S = CARRY IN WARRANTY (EFFECTIVE 02/96) X = IN HOME WARRANTY (EFFECTIVE 02/96)										
YEAR OF INTRODUCTION J = 2000, K = 2001, L = 2002										
COLOR CODE B = BLACK, Q = WHITE, T = BISCUIT										
ENGINEERING CHANGE (0, 1, 2, ETC.)										

SERIAL NUMBER

SERIAL NUMBER	FG	L	25	54321
MANUFACTURING SITE FG = FINDLAY, OH				
YEAR OF PRODUCTION K = 2000, L = 2001				
WEEK OF PRODUCTION 25TH WEEK				
PRODUCT SEQUENCE NUMBER				

MODEL & SERIAL NUMBER LABEL AND TECH SHEET LOCATIONS

The Model/Serial Number label and Tech Sheet locations are shown below.



**Model & Serial
Number Location**

**Tech Sheet Location
(Behind Grille)**



SPECIFICATIONS

WHIRLPOOL

MODEL	MH6140XKQ/B	MH6141XKQ/B
Size-Configuration	1.4 cu ft	1.4 cu ft
Feature Level/Series	Basic Non Sensor	Basic Non Sensor
DIMENSIONS / SPECIFICATIONS		
Outside Dimensions	29-15/16" W x 16-7/16" H x 15-3/8" D	29-15/16" W x 16-7/16" H x 15-3/8" D
Interior Cavity Dimensions	19-7/8" W x 8-15/16" H x 14-3/16" D	19-7/8" W x 8-15/16" H x 14-3/16" D
CONTROL SYSTEM		
Timer	Electronic	Electronic
Limits	99 Min. 99 Sec.	99 Min. 99 Sec.
Scale	Linear (Digital)	Linear (Digital)
Display	7 Digit Display Scroll VFD	7 Digit Display Scroll VFD
OTHER FEATURES		
Stoppable Turntable	No	No
Child Lock	Yes - Start / Enter Button	Yes - Start / Enter Button
Variable Power (Cook Power)	Yes	Yes
Type	Electronic	Electronic
Range	10% - 100%	10% - 100%
Scale	Digital	Digital
Levels	Ten	Ten
Auto On	Yes - 56 degrees C	Yes - 56 degrees C
Cooktop Light	Yes - One (1)	Yes - One (1)
On	Yes	Yes
Night	Yes	Yes
Manual Off	Yes	Yes
Auto Off	No	No
Wattage	30 Watts	30 Watts
Light Cover	Glass	Glass
Start Indication	"Touch Start" Scroll display	"Touch Start" Scroll display
Probe Temp Indication	N/A	N/A
Weight Indication	"Lbs"	"Lbs"
Clock Set	"ENTER TIME OF DAY"	"ENTER TIME OF DAY"
Independent Minute Timer	"ENTER TIME IN MIN AND SEC"	"ENTER TIME IN MIN AND SEC"
INTERIOR		
Size	19-7/8" W x 8-15/16" H x 14 -5/32" D	19-7/8" W x 8-15/16" H x 14 -5/32" D
Capacity	1.4 Cubic Feet	1.4 Cubic Feet
Finish	Epoxy Powder Coat	Epoxy Powder Coat
Cooking Power	950 Watts (1EC-705 Rating)	950 Watts (1EC-705 Rating)
Ventilation	Forced Air	Forced Air
Shelf	Spillguard Sealed-In	Spillguard Sealed-In
Bi-Level Rack	No	No
Interior Light	Yes-Automatic turns on when oven door is open or oven is operating 30 watts (2000 hr. life)	Yes-Automatic turns on when oven door is open or oven is operating 30 watts (2000 hr. life)
Turntable Diameter	12-3/4"	12-3/4"
Stoppable Turntable	No	No
EXTERIOR		
Window	Water Clear Glass	Water Clear Glass
Window Size	18-1/4" W x 7-1/2" H	18-1/4" W x 7-1/2" H
Door / Window Graphics	Whirlpool Logo on Door; upper left corner	Whirlpool Logo on Door; upper left corner
Outer Door	Stamped Steel with tempered cover	Stamped Steel with tempered cover
Handle/Latch	Pull to open	Pull to open
Seals	Three Stage (Capacitive, Reflective & Absorbive)	Three Stage (Capacitive, Reflective & Absorbive)

MODEL	MH6140XKQ/B	MH6141XKQ/B
EXTERIOR FEATURES		
Outside Dimensions	29-15/16" W x 16-7/16" H x 15-3/8" D	29-15/16" W x 16-7/16" H x 15-3/8" D
Control and Door Frames	One Piece Molded	One Piece Molded
Cooktop Light w/Touch Control	One Lamp - 30 Watt Easy Access	One Lamp - 30 Watt Easy Access
Power Cord Length	3.28 Ft.	3.28 Ft.
MISCELLANEOUS		
MICROWAVE SYSTEM		
Distribution	Regular Side Feeding	Regular Side Feeding
Magnetron	Standard	Standard
SAFETY FEATURES		
Interlock	Three Door/Latch Operated Switches (1 Power Interrupt, 1 Monitor, 1 Low Voltage	Three Door/Latch Operated Switches (1 Power Interrupt, 1 Monitor, 1 Low Voltage
Thermal Protectors	One (1) - Oven Cavity	One (1) - Oven Cavity
VENTILATION SYSTEM		
Type	Convertible	Convertible
Duct Outlet Size	10 " W x 3-1/4 "H	10 " W x 3-1/4 "H
Recirculation CFM	148 (Hi with Charcoal Filter)	148 (Hi with Charcoal Filter)
Horizontal CFM (Hi-Low)	223CFM / 112 CFM	223CFM / 112 CFM
Vertical CFM (Hi-Low)	220 CFM / 110 CFM	220 CFM / 110 CFM
Touch Control (2-speed)	Two Speed (Hi / Low)	Yes - High / Low
Auto ON - High Speed	Yes - 56°C	Yes - 56°C
Noise Level	43 dBA (Microwave Only)	43dBA (Microwave Only)
Damper	Yes	Yes
Grease Filter	Yes - (2)	Yes (2)
Charcoal Filter	Yes - (1)	Yes - (1)
Blower Type	Twin Squirrel Cage	Twin Squirrel Cage
Shipped	Recirculating Mode	Recirculating Mode
OTHER SPECIFICATIONS		
Electrical	120V, Single Phase, 60 Hz, 1500 Watts, For Use With 20 Amp Circuit	120V, Single Phase, 60 Hz, 1500 Watts, For Use With 20 Amp Circuit
Domestic Use Only	Yes	Yes
Agency Approvals	FCC, DHHS, U.L. Listed	FCC, DHHS, U.L. Listed
Approx. Shipping Weight	58 lbs.	58 lbs.
Approx. Net Weight	52 lbs.	52 lbs.
Carton Dimensions	33-7/16" W x 19-5/16" H x 19-17/32" D	33-7/16" W x 19-5/16" H x 19-17/32" D
LITERATURE		
Use & Care Guide	8183890 / 3828W5A1876 (English)	8183890 / 3828W5A1876 (English)
Job Aid	8178053	8178053
Cooking Guide	8183893 / 3850W3D032B (English)	8183893 / 3850W3D032B (English)
Installation Instructions	8183895 / 3828W5U0125 (English)	8183895 / 3828W5U0125 (English)
Upper Cabinet Template	8183896 / 4922W5A025A (English)	8183896 / 4922W5A025A (English)
Wall Template	No	No
Warranty	In Use & Care Guide	In Use & Care Guide
Carton Tag	Std. - On Carton Corner	Std. - On Carton Corner
Tech Sheet	8183894 / 3840W3T001G (English)	8183894 / 3840W3T001G (English)
ACCESSORIES		
Filler Kit	4158311	4158311
Charcoal Filter	8183916 / 2B72706D	8183916 / 2B72706D
Grease Filter	4358853 / 2B72705B	4358853 / 2B72705B
Exhaust Damper Assembly	Yes (1 Set)	Yes (1 Set)
Trim Kit	No	No
Hardware for Installation	Yes (1 Set)	Yes (1 Set)

ROPER

MODEL	MHE14XKQ/B
Size-Configuration	1.4 cu ft
Feature Level/Series	Basic Non Sensor
DIMENSIONS / SPECIFICATIONS	
Outside Dimensions	29-15/16" W x 16-7/16" H x 15-3/8" D
Interior Cavity Dimensions	19-7/8" W x 8-15/16" H x 14-3/16" D
CONTROL SYSTEM	
Timer	No
Type	N/A
Limits	N/A
Scale	N/A
Display	7 Digit Display Scroll VFD
OTHER FEATURES	
Stoppable Turntable	No
Clock	Yes
Child Lock	Yes - Start / Enter Button
Variable Power (Cook Power)	Yes
Type	Electronic
Range	10% - 100% (increments of 10%)
Scale	Digital
Levels	Ten (10)
Operation	Direct Entry
Ventilation	Forced Air
Exhaust Fan	Yes
High	Yes (220 CFM) - Vertical
Low	Yes (110 CFM) - Vertical
Manual Off	Yes
Auto Off	No
Auto On	Yes - 56 degrees C
Cooktop Light	Yes - One (1)
On	Yes (30 Watts)
Night	Yes (17 Watts)
Manual Off	Yes
INTERIOR	
Size	19-7/8" W x 8-15/16" H x 14 -3/16" D
Capacity	1.4 Cubic Feet
Finish	Epoxy Powder Coat
Cooking Power	950 Watts (1EC-705 Rating)
Ventilation	Forced Air
Shelf	No
Bi-Level Rack	No
Interior Light	Yes-Automatic turns on when oven door is open or oven is operating 30 watt (2000 hr. life)
Turntable Diameter	12-3/4"
Stoppable Turntable	No
Turntable Roller	Yes
EXTERIOR	
Window Size	17" W x 6-7/8" H

MODEL	MHE14XKQ/B
EXTERIOR FEATURES	
Outside Dimensions	29-15/16" W x 16 7/16" H x 15-3/8" D
Wrapper Material	For Black Model: Black Textured VCM For White Model: PCM NON-Textured Steel
Cooktop Light w/Touch Control	One Lamp - 30 Watt Easy Access
Power Cord Length	3.28 Ft.
MISCELLANEOUS	
MICROWAVE SYSTEM	
Distribution	Side Feed
Magnetron	Standard
SAFETY FEATURES	
Interlock	Three Door/Latch Operated Switches (1 Power Interrupt, 1 Monitor, 1 Low Voltage)
Thermal Protectors	One (1) for Oven Cavity
VENTILATION SYSTEM	
Type	Convertible
Duct Outlet Size	10 " W x 3-1/4 " H
Recirculation CFM	148 (Hi with Charcoal Filter)
Horizontal CFM (Hi-Low)	223CFM / 112 CFM
Vertical CFM (Hi-Low)	220 CFM / 110 CFM
Touch Control (2-speed)	Two Speed (Hi / Low)
Auto ON - Low Speed	Yes - 56°C
Noise Level	53.5 dBA (Ventilation Mode)
Damper	Yes
Grease Filter	Yes - (2)
Charcoal Filter	Yes - (1)
Blower Type	Twin squirrel cage
Shipped	Recirculating Mode
OTHER SPECIFICATIONS	
Electrical	120V, Single Phase, 60 Hz, 1500 Watts, For Use With 20 Amp Circuit
Domestic Use Only	Yes
Agency Approvals	FCC, DHHS, U.L. Listed
Approx. Shipping Weight	58 lbs.
Approx. Net Weight	52 lbs.
LITERATURE	
Use & Care Guide	Whpl # 8183914 / 3828W5A1906 (English)
Cooking Guide	Whpl # 8183915 / 3850W3D032D (English)
Installation Instructions	8183895 / 3828W5U0125 (English)
Upper Cabinet Template	8183896 / 4922W5A025A (English)
Wall Template	No
Warranty	In Use & Care Guide
Carton Tag	Std. - On Carton Corner
Model Serial Plate Location	Upper Front Frame
Cooking Guide Location	Upper Front Frame
Tech Sheet	8183894 / 3840W3T001G (English)
Job Aid	8178053
ACCESSORIES	
Filler Kit	4158311
Charcoal Filter	8183916 / 2B72706D
Grease Filter	4358853 / 2B72705B
Exhaust Damper Assembly	Yes (1 Set)
Trim Kit	No
Hardware for Installation	Yes (1 Set)

WHIRLPOOL MICROWAVE OVEN WARRANTY

LENGTH OF WARRANTY:	WHIRLPOOL WILL PAY FOR:	WHIRLPOOL WILL NOT PAY FOR:
<p>ONE-YEAR FULL WARRANTY From Date of Purchase.</p>	<p>FSP[®] Replacement parts and repair labor costs to correct defects in materials or workmanship. Service must be provided by a Whirlpool-designated servicing company.</p>	<p>A. Service calls to:</p> <ol style="list-style-type: none"> 1. Correct the installation of the microwave oven. 2. Instruct you how to use the microwave oven. 3. Replace house fuses or correct house wiring. 4. Replace owner-accessible light bulbs. <p>B. Repairs when microwave oven is used in other than normal single-family household use.</p>
<p>LIMITED FOUR-YEAR WARRANTY Second through fifth year from Date of Purchase.</p>	<p>FSP[®] Replacement magnetron tube on microwave ovens if defective in materials or workmanship.</p>	<p>C. In-home service. Your microwave oven must be taken to a Whirlpool-designated service company, except when your microwave oven is installed over an approved oven using an approved built-in kit.</p> <p>D. Damage to the microwave oven resulting from accident, alteration, misuse, abuse, fire, flood, acts of God, or use of products not approved by Whirlpool Corporation.</p> <p>E. Any labor costs during the limited warranty.</p> <p>F. Repairs to parts or systems resulting from unauthorized modifications made to the appliance.</p> <p>G. Replacement parts or repair labor costs for units operated outside the United States.</p>

WHIRLPOOL CORPORATION SHALL NOT BE LIABLE FOR INCIDENTAL OR CONSEQUENTIAL DAMAGES. Some states do not allow the exclusion or limitation of incidental or consequential damages, so this exclusion or limitation may not apply to you. This warranty gives you specific legal rights, and you may also have other rights which vary from state to state.

Outside the United States, this warranty does not apply. Contact your authorized Whirlpool dealer to determine if another warranty applies.

If you need service, see the "Requesting Assistance or Service" in the Use & Care Guide, or by calling our Customer Interaction Center telephone number, **1-800-253-1301**, from anywhere in the U.S.A.

— NOTES —

THEORY OF OPERATION

THE VENT MOTOR MOUNTING POSITIONS

RECIRCULATING AIR

AIRFLOW TOWARDS FRONT OF UNIT

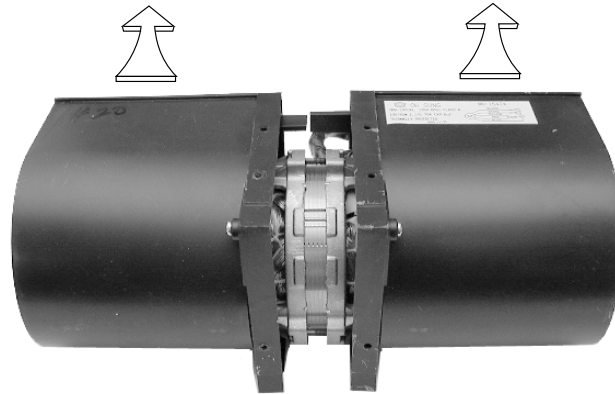

REAR VENTED AIR

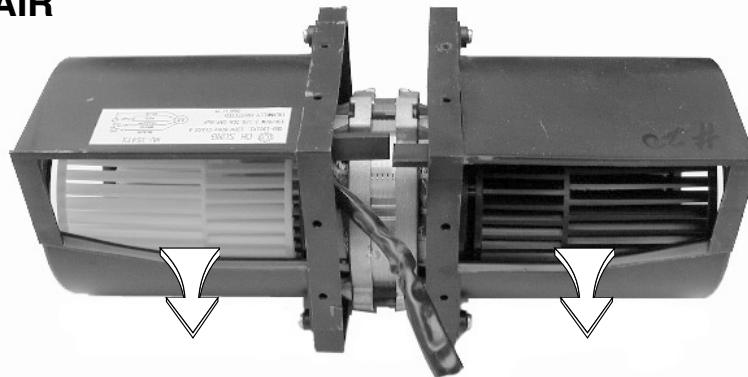

AIRFLOW TOWARDS REAR OF UNIT

TOP VENTED AIR

AIRFLOW TOWARDS TOP OF UNIT

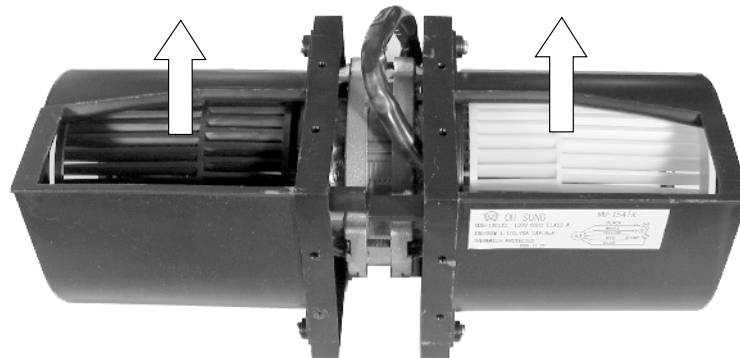

NOTE: All microwave ovens are shipped with the vent motor in the “Top Vented Air” position.

THE OVEN THERMOSTAT & VENT MOTOR CAPACITOR

OVEN THERMOSTAT



The oven thermostat is located in the high voltage section of the oven and is accessed by removing the control panel. The thermostat is normally-closed and will open at a set temperature to disable the oven. The "trip" temperature is 194°F (90°C). The thermostat is resettable.

VENT MOTOR CAPACITOR

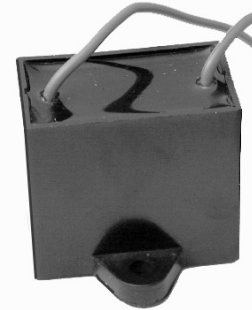

The vent motor capacitor is located in the high voltage area of the oven and is accessed by removing the control panel. It is in use any time the vent motor is in operation. The capacitor helps to maintain a constant voltage to the vent motor so that it runs smoother and more efficiently.

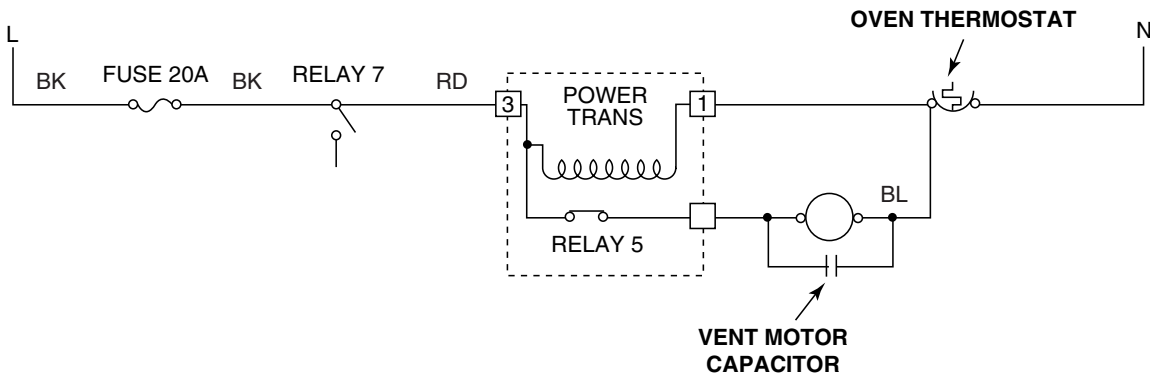

THE VENT & TURNTABLE MOTORS

THE VENT MOTOR

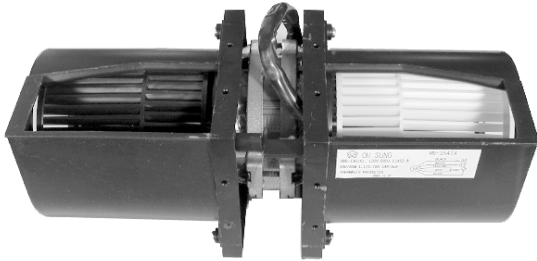

The vent motor removes smoke and odors from the kitchen cooking area through outside venting or by recirculation.

THE TURNTABLE MOTOR



The turntable motor is a synchronous motor that turns the food so that microwave energy entering it is evenly distributed during cooking.

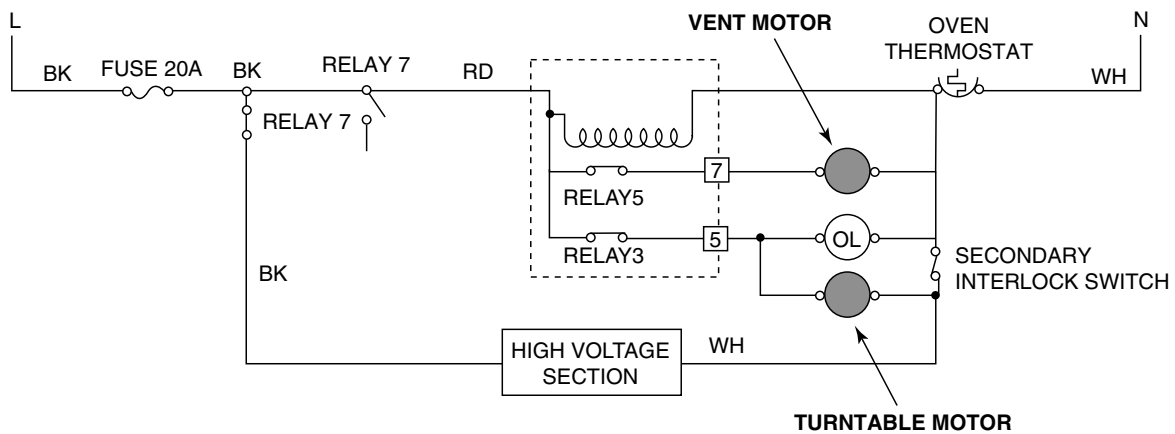

— NOTES —

COMPONENT ACCESS

This section instructs you on how to service each component inside the Model MH6140XK Microwave Oven Hood Combination. The components and their locations are shown below.

COMPONENT LOCATIONS

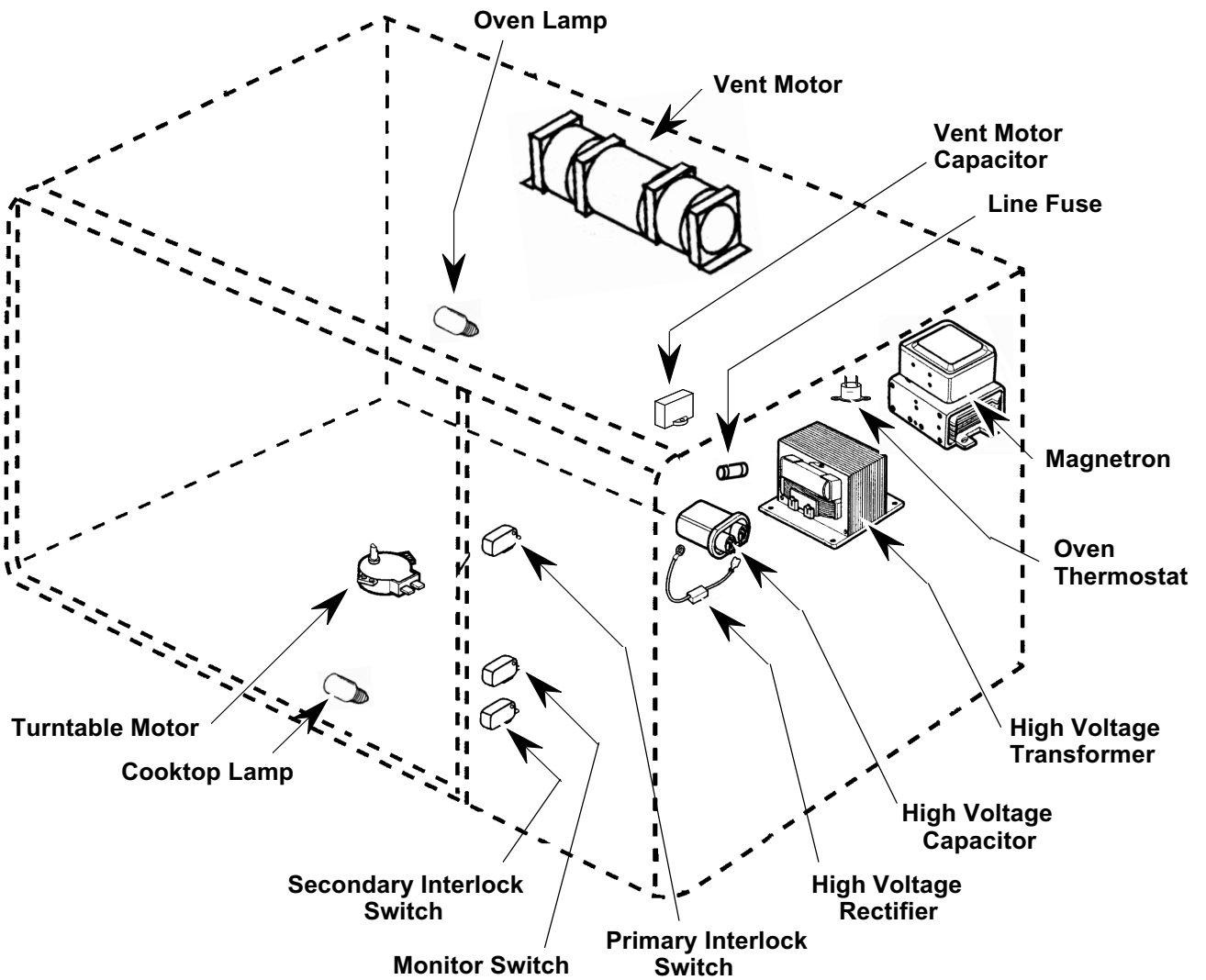

REMOVING THE TURNTABLE MOTOR & COOKTOP LAMP ASSEMBLY

! WARNING

ELECTRICAL SHOCK HAZARD

Disconnect power before servicing.
Replace all panels before operating.
Failure to do so could result in death or electrical shock.

CAUTION: When you work on the microwave oven, be careful when handling the sheet metal parts. Sharp edges may be present, and you can cut yourself if you are not careful.

1. Disconnect the electrical power to the microwave oven.
2. Remove the seven screws from the bottom cover and partially lower the top edge of the cover so you can access the component wiring below it.



Screw (1 of 7)

3. Lower the bottom cover as far as possible.

4. To remove the turntable motor:

- a) Remove the glass turntable, roller assembly, and spindle from inside the oven cavity.

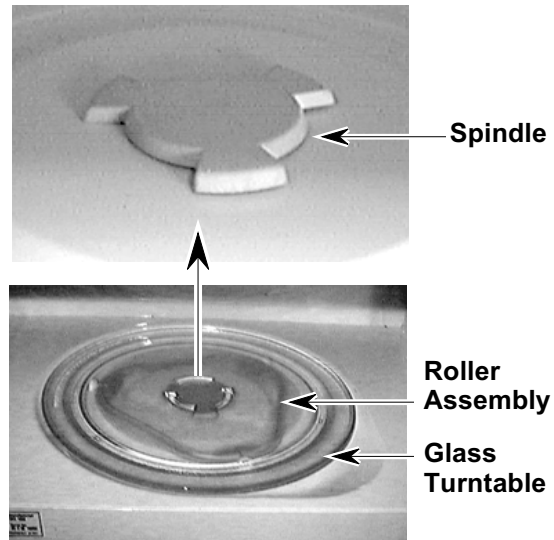

- b) Disconnect the turntable motor connector.

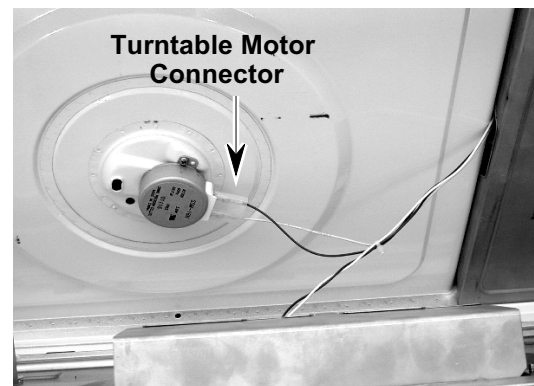

- c) Remove the two screws from the turntable motor and remove the motor.



5. **To remove the cooktop lamp assembly:**

- a) Turn the cooktop lamp socket counter-clockwise and align the socket tabs with the cover slots, then remove the lamp assembly.
b) Remove the bulb from the socket.

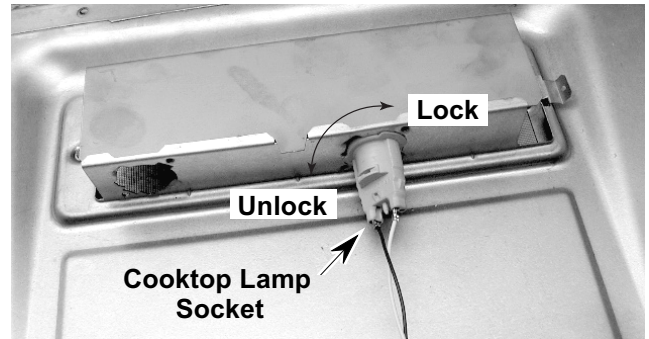

NOTE: When you reinstall the bottom cover, place the edge below the five tabs, as shown below.

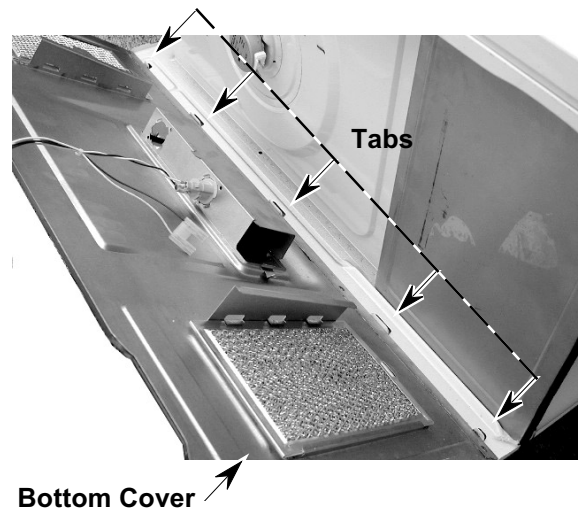

REMOVING THE CONTROL PANEL & CONTROL BOARD

! WARNING

ELECTRICAL SHOCK HAZARD

Disconnect power before servicing.
Replace all panels before operating.
Failure to do so could result in death or electrical shock.

CAUTION: When you work on the microwave oven, be careful when handling the sheet metal parts. Sharp edges may be present, and you can cut yourself if you are not careful.

1. Disconnect the electrical power to the microwave oven.
2. Remove the two outer screws from the top of the cabinet.
3. Pull the top of the air grille forward, lift the bottom tabs from the slots, and remove the grille from the microwave oven.



4. Open the microwave oven door.

5. Remove the screw from the top of the control panel and pull the top forward.



6. Disconnect the 2- and 11-pin connectors from the control board and remove the control panel assembly.

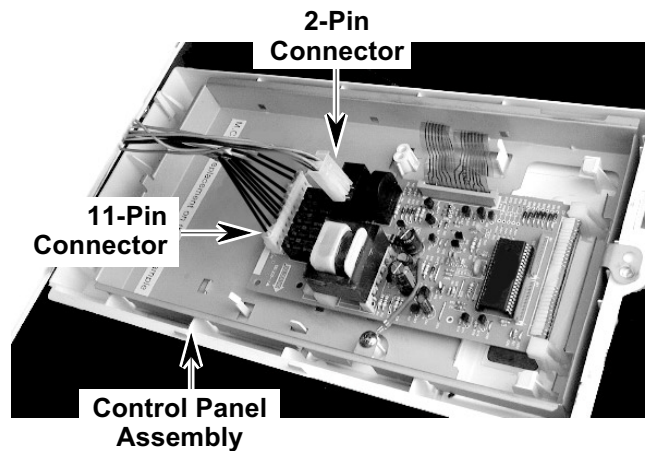

7. Place your fingertips under the ends of the ribbon cable connector locking rail and lift the rail, then pull the end of the ribbon cable out of the connector.

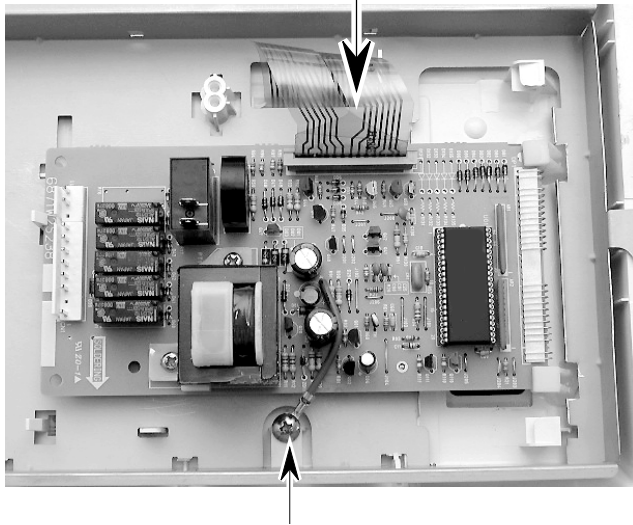
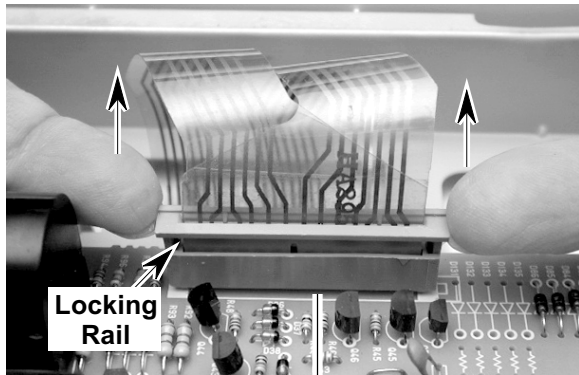

8. Remove the green ground wire screw from the control panel.

9. Remove the two screws from the transformer bracket.

Transformer Bracket Screws

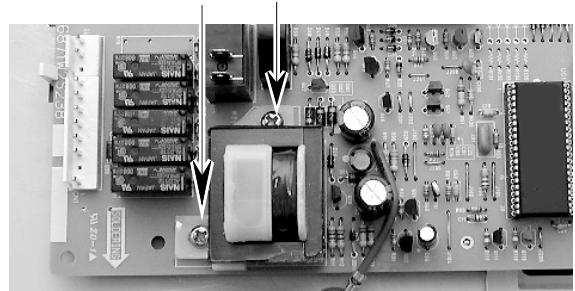

10. Press the locking tab and unlock it from the end of the control board, then pull the other end of the board out of the holder slots, and remove the board.

REMOVING THE DOOR SWITCHES

! WARNING

ELECTRICAL SHOCK HAZARD

Disconnect power before servicing.
Replace all panels before operating.
Failure to do so could result in death or electrical shock.

CAUTION: When you work on the microwave oven, be careful when handling the sheet metal parts. Sharp edges may be present, and you can cut yourself if you are not careful.

1. Disconnect the electrical power to the microwave oven.
2. Remove the control panel from the microwave oven (see page 3-4 for the procedure).

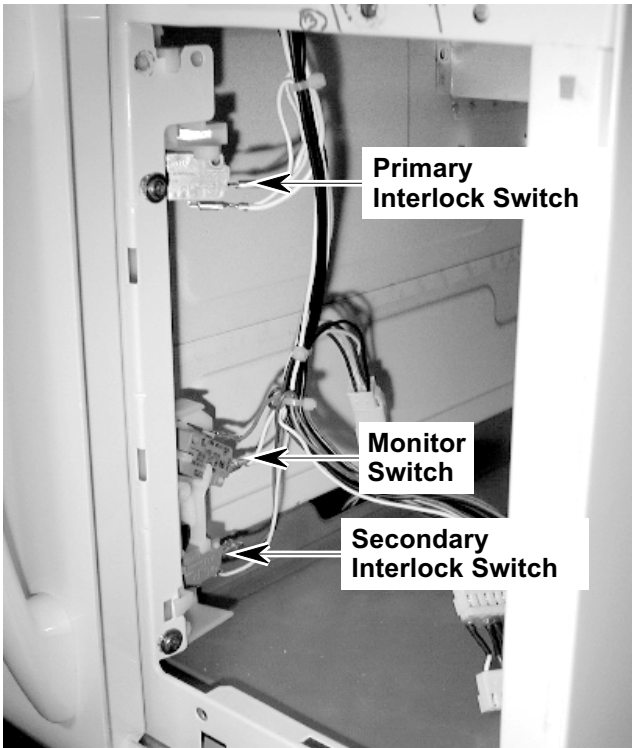

3. To remove the primary interlock switch:
 - a) Disconnect the wire connectors from the terminals.

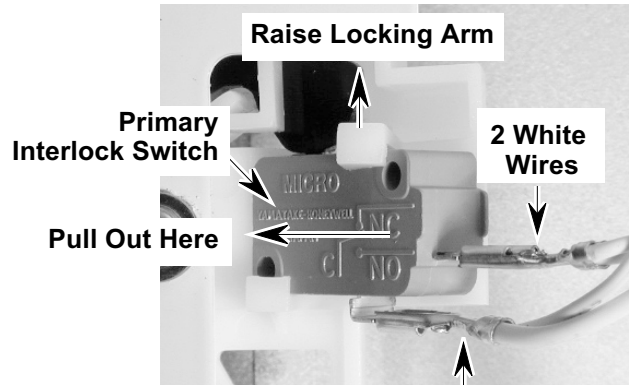

2 White Wires
(1 Large & 1 Small)

- b) Carefully raise the locking arm, pull out, and remove the switch from the bracket.
4. To remove the monitor switch or secondary interlock switch:
 - a) Disconnect the wire connectors from the terminals.

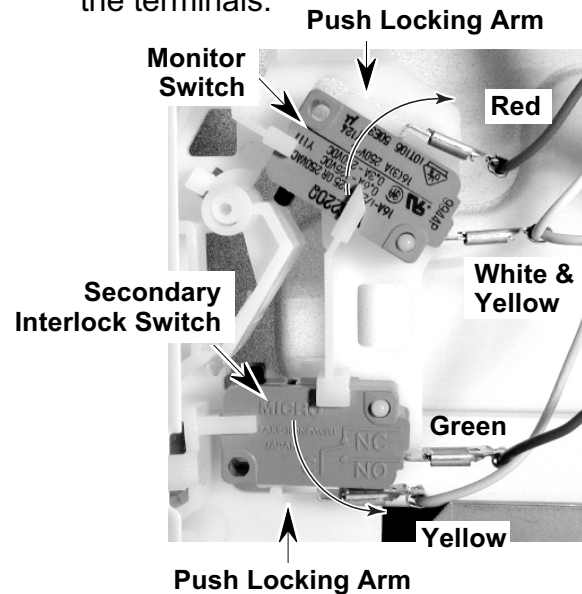

- b) Carefully push in on the locking arm (be careful not to break it off) while you twist the switch on the pivot pin, and remove the switch from the bracket. NOTE: If a locking arm breaks, you will have to replace the entire bracket, so be careful when bending the arms.

REMOVING THE OVEN LAMP ASSEMBLY

! WARNING

ELECTRICAL SHOCK HAZARD

Disconnect power before servicing.
Replace all panels before operating.
Failure to do so could result in death or electrical shock.

CAUTION: When you work on the microwave oven, be careful when handling the sheet metal parts. Sharp edges may be present, and you can cut yourself if you are not careful.

1. Disconnect the electrical power to the microwave oven.
2. Remove the two outer screws from the top of the cabinet.
3. Pull the top of the air grille forward, lift the bottom tabs from the slots, and remove the grille from the microwave oven.



4. Lift the oven lamp mounting bracket by its tab and remove the lamp assembly from the mounting location. NOTE: Be careful not to break the fragile wire socket connectors.

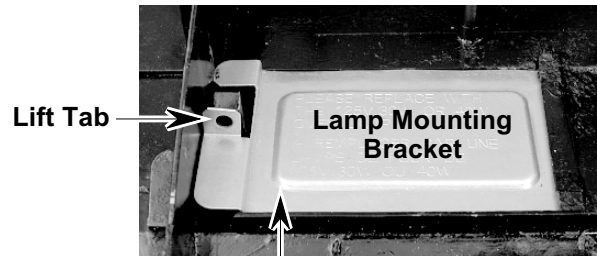

5. Facing the rear of the socket, turn it counterclockwise and align the socket locking tabs with the bracket slots, and remove the socket.

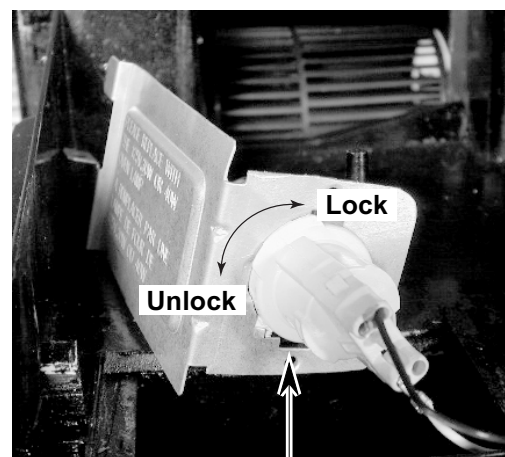

Lamp Socket Slot

6. Remove the bulb from the socket.

REMOVING THE OVEN THERMOSTAT, LINE FUSE, & POWER CORD

! WARNING

ELECTRICAL SHOCK HAZARD

Disconnect power before servicing.
Replace all panels before operating.
Failure to do so could result in death or electrical shock.

CAUTION: When you work on the microwave oven, be careful when handling the sheet metal parts. Sharp edges may be present, and you can cut yourself if you are not careful.

1. Disconnect the electrical power to the microwave oven.
2. Remove the control panel from the microwave oven (see page 3-4 for the procedure).
3. Remove the high voltage access panel from over the control panel opening.

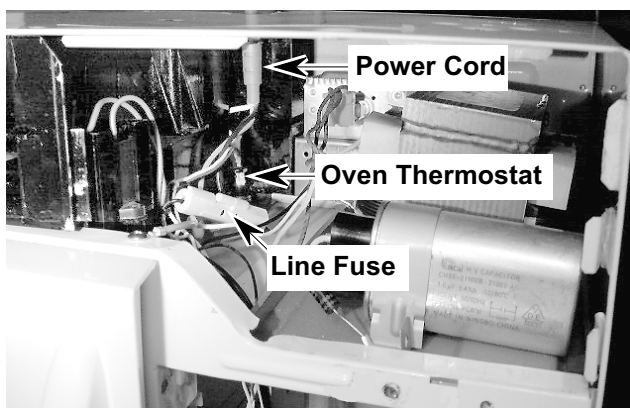
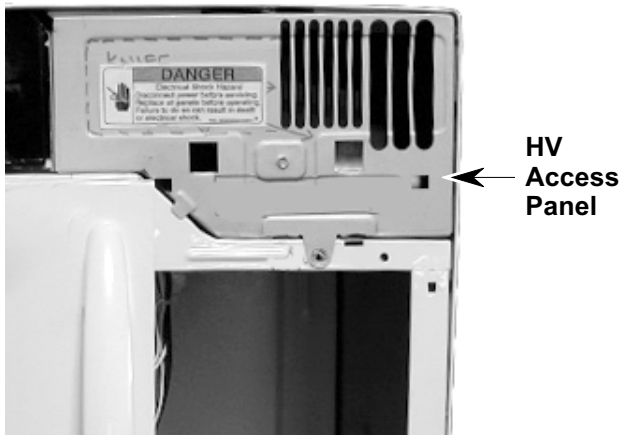

4. To remove the oven thermostat:

- a) Remove the wires from the terminals.
- b) Position the terminals so they align with the air cover slot and slide the thermostat out of the slot.

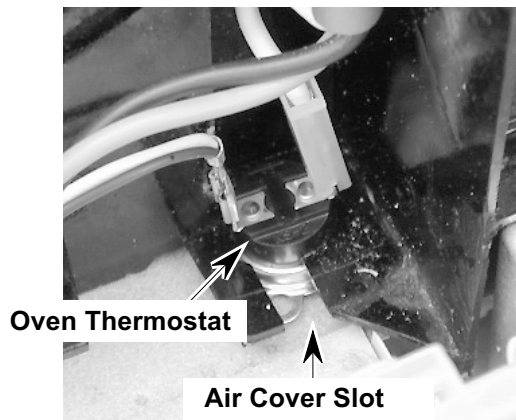

5. To remove the line fuse:

- a) Open the fuseholder.

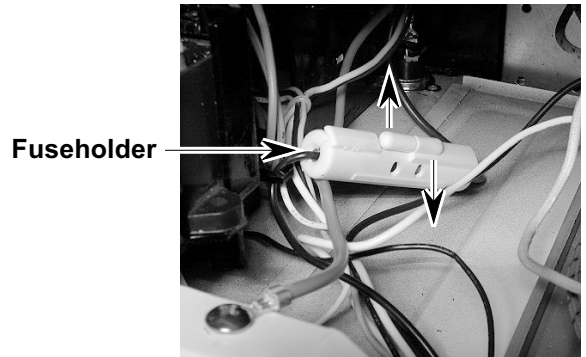

- b) Pull the clips off the ends of the 20A line fuse and remove the fuse from the fuseholder.

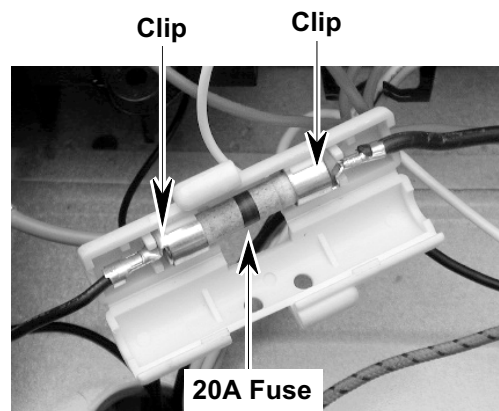

6. **To remove the power cord:**
- a) Remove the black wire with clip from the line fuse.
 - b) Remove the green ground wire screw.

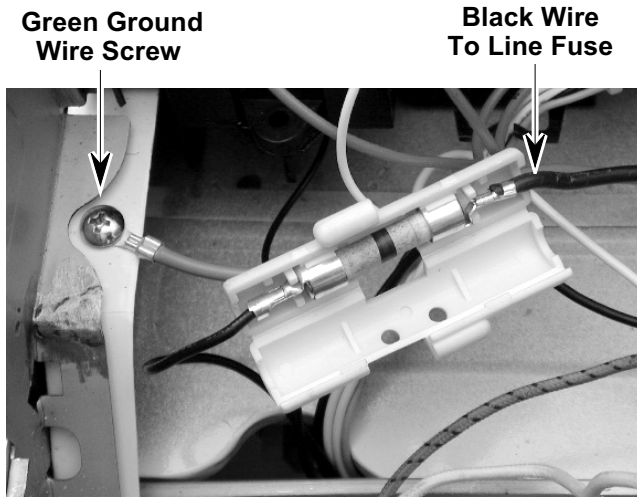

- c) Remove the white wire connector from the oven thermostat terminal.

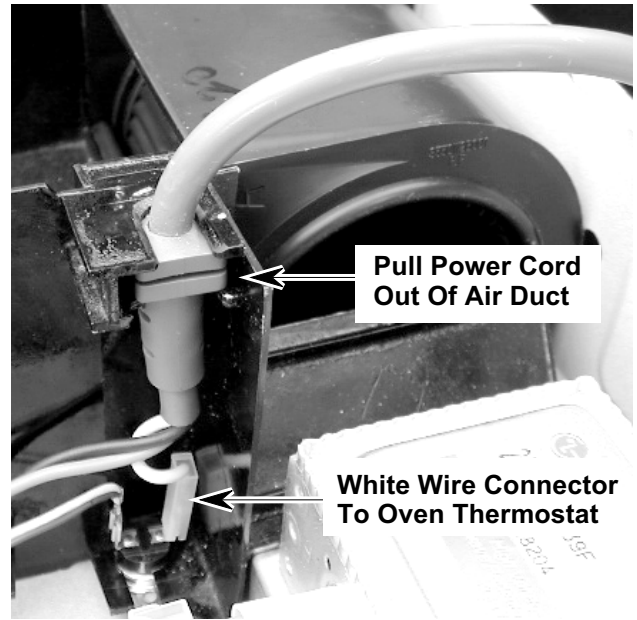

- d) Slide the power cord out of the air duct holder slots.

REMOVING THE VENT MOTOR CAPACITOR, THE HIGH VOLTAGE CAPACITOR & RECTIFIER

! WARNING

ELECTRICAL SHOCK HAZARD

Disconnect power before servicing.
Replace all panels before operating.
Failure to do so could result in death or electrical shock.

CAUTION: When you work on the microwave oven, be careful when handling the sheet metal parts. Sharp edges may be present, and you can cut yourself if you are not careful.

1. Disconnect the electrical power to the microwave oven.
2. Remove the control panel from the microwave oven (see page 3-4 for the procedure).
3. Remove the high voltage access panel from over the control panel opening (see page 3-8, step 3).
4. **CAUTION: Discharge the high voltage capacitor with a 20,000 Ω resistor to chassis ground.**

Vent Motor Capacitor

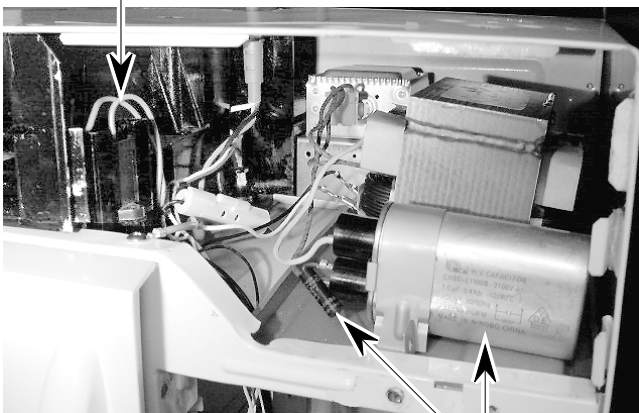

HV Capacitor &
HV Rectifier

5. To remove the vent motor capacitor:
 - a) Cut the wires near the body of the capacitor.
 - b) Unsnap the capacitor from the holder and lift it out of the holder.

Vent Motor Capacitor

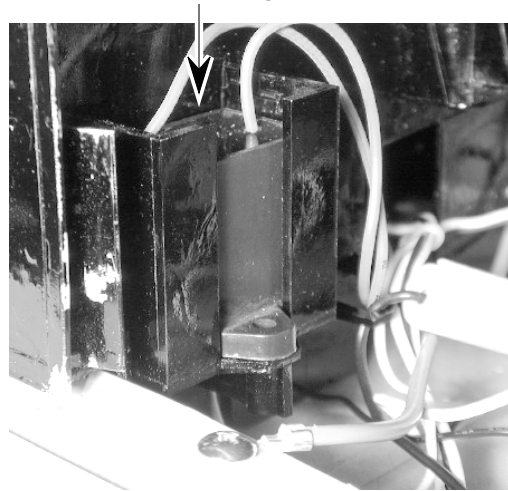

6. Splice the wires on the new capacitor to the old capacitor wires.
7. To remove the high voltage capacitor and high voltage rectifier:
 - a) Disconnect the wires and rectifier lead from the terminals of the high voltage capacitor.
 - b) Remove the mounting screw from the clamp and remove the rectifier and capacitor.

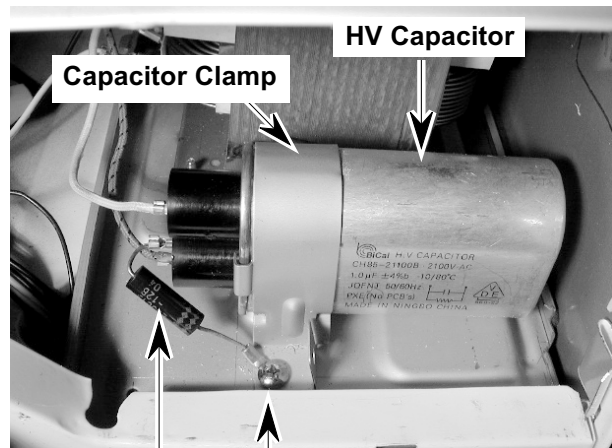

HV Rectifier Mounting Screw

REMOVING THE HIGH VOLTAGE TRANSFORMER

! WARNING

ELECTRICAL SHOCK HAZARD

Disconnect power before servicing.
Replace all panels before operating.
Failure to do so could result in death or electrical shock.

CAUTION: When you work on the microwave oven, be careful when handling the sheet metal parts. Sharp edges may be present, and you can cut yourself if you are not careful.

1. Disconnect the electrical power to the microwave oven.
2. Remove the control panel from the microwave oven (see page 3-4 for the procedure).
3. Remove the high voltage access panel from over the control panel opening (see page 3-8, step 3).
4. **CAUTION: Discharge the high voltage capacitor with a 20,000 Ω resistor to chassis ground.**
5. Remove the high voltage capacitor and high voltage rectifier (see page 3-10 for the procedure).

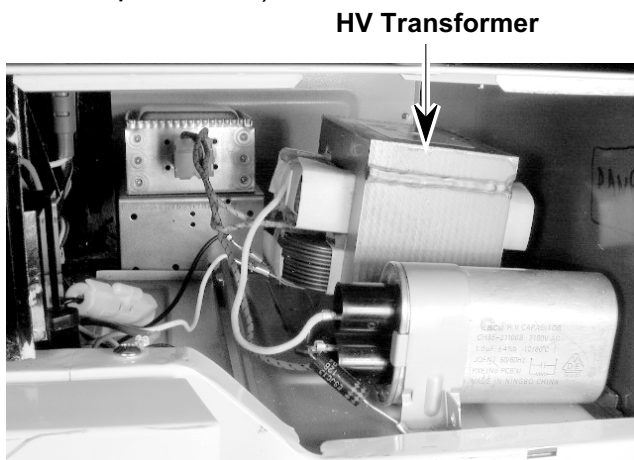

6. Disconnect the white and black wires from the two terminals on the high voltage transformer.
7. Disconnect the 3-wire connector from the magnetron.

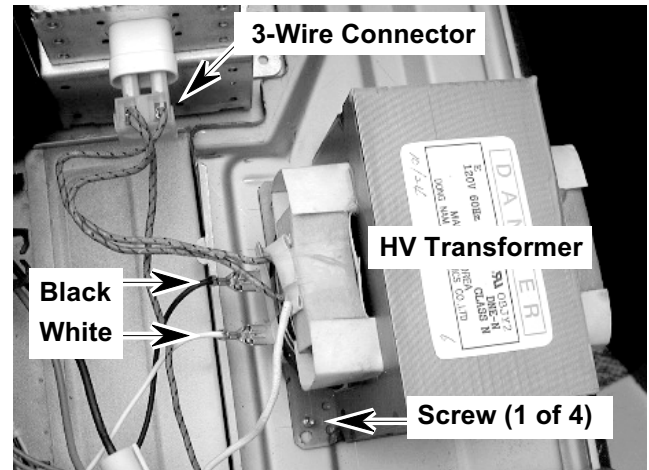

8. Remove the four screws from the high voltage transformer (below the mounting plate) and remove the transformer.

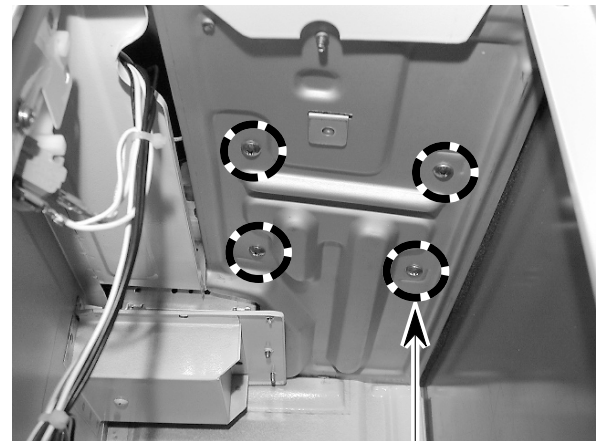

REMOVING THE MAGNETRON

! WARNING

ELECTRICAL SHOCK HAZARD

Disconnect power before servicing.
Replace all panels before operating.
Failure to do so could result in death or electrical shock.

CAUTION: When you work on the microwave oven, be careful when handling the sheet metal parts. Sharp edges may be present, and you can cut yourself if you are not careful.

1. Disconnect the electrical power to the microwave oven.
2. Remove the control panel from the microwave oven (see page 3-4 for the procedure).
3. Remove the high voltage access panel from over the control panel opening (see page 3-8, step 3).
4. **CAUTION:** Discharge the high voltage capacitor with a 20,000 Ω resistor to chassis ground.

5. Remove the high voltage capacitor and high voltage rectifier (see page 3-10 for the procedure), and the high voltage transformer (see page 3-11 for the procedure).

Magnetron

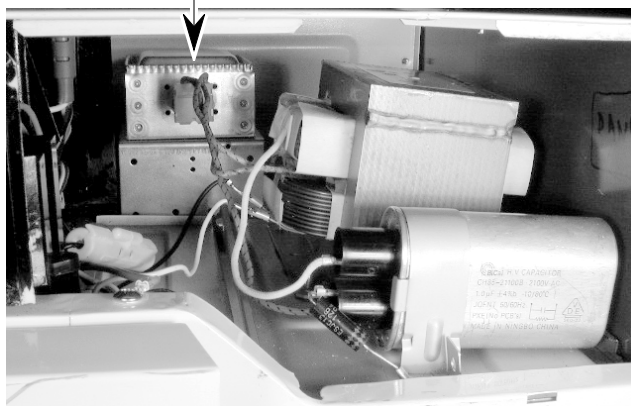

6. Remove the screw from the end of the mounting bracket, lift the end of the bracket, and remove the magnetron from the unit.

Magnetron

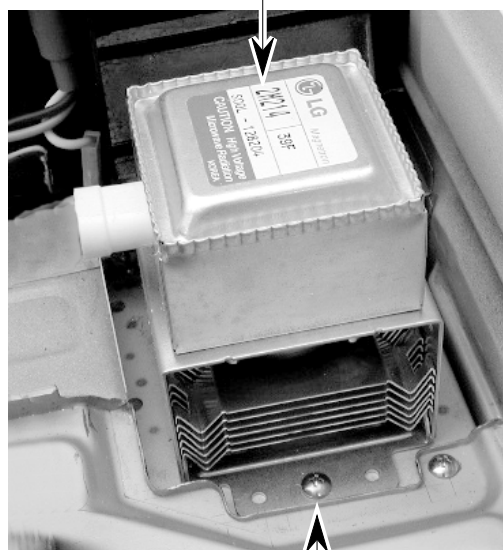

Screw

REMOVING THE VENT MOTOR

! WARNING

ELECTRICAL SHOCK HAZARD

Disconnect power before servicing.
Replace all panels before operating.
Failure to do so could result in death or electrical shock.

CAUTION: When you work on the microwave oven, be careful when handling the sheet metal parts. Sharp edges may be present, and you can cut yourself if you are not careful.

1. Disconnect the electrical power to the microwave oven.
2. Remove the glass turntable and roller assembly from inside the oven cavity.

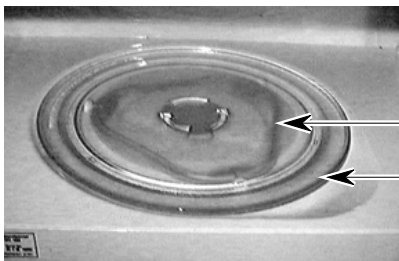

Roller
Assembly
Glass
Turntable

3. Remove the microwave oven from its mounting location.
4. Remove the three screws from the air vent cover on the top of the cabinet and remove the cover.

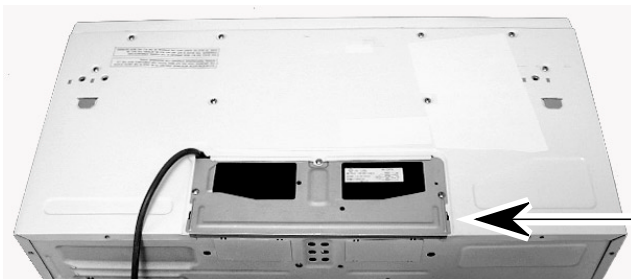

5. Remove the vent motor mounting screw from the rear panel.



Vent Motor Screw

6. Lift the vent motor out of the opening at the rear of the oven and disconnect the power connector from the main harness connector.

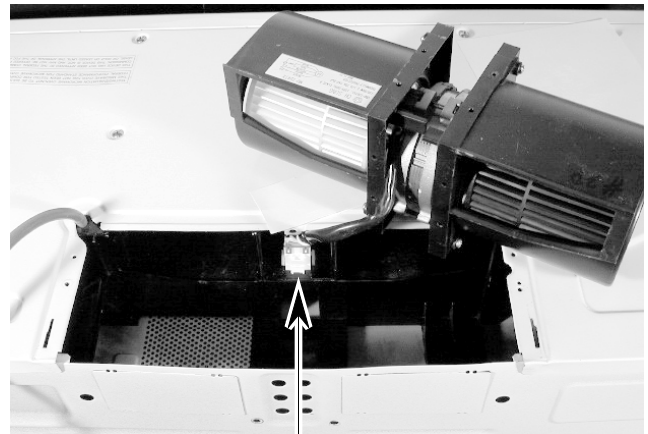

Vent Motor Power Connector

Air Vent Cover
3 Screws



REMOVING THE OVEN DOOR, THE SWITCH ACTUATORS, AND THE OUTER GLASS

! WARNING

ELECTRICAL SHOCK HAZARD

Disconnect power before servicing.
Replace all panels before operating.
Failure to do so could result in death or electrical shock.

CAUTION: When you work on the microwave oven, be careful when handling the sheet metal parts. Sharp edges may be present, and you can cut yourself if you are not careful.

1. Disconnect the electrical power to the microwave oven.
2. Open the microwave oven door and remove the choke cover. To do this:
 - a) Use a small screwdriver and pry out on the indicated corner of the choke cover until the bottom locking tab pops out.

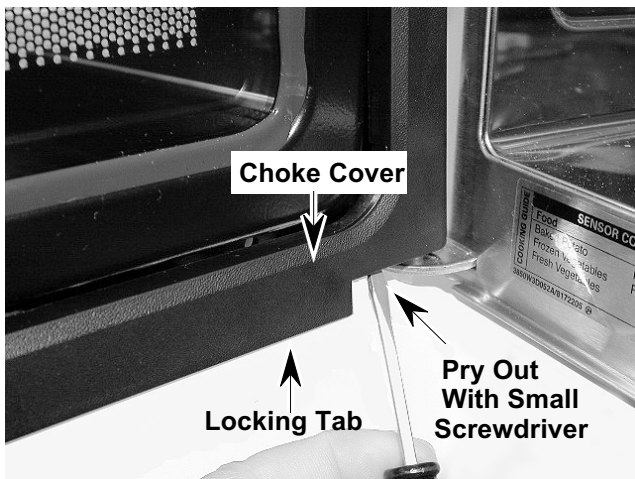

- b) Use a putty knife and pry out along the inner edge of the choke cover.
- c) Pull out on the cover to release all of the locking tabs, and remove the cover from the door.

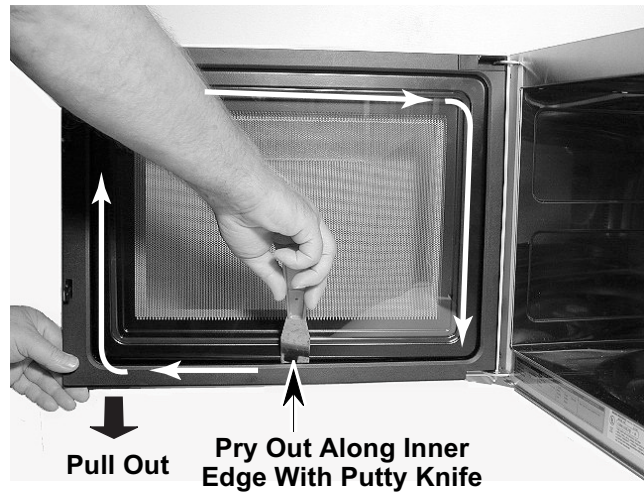

3. To remove the oven door:

- a) Lift the door and remove the bottom hinge pin from its bracket hole, then lower the door and remove the top hinge pin from its bracket hole.



- b) Place the door on a padded surface with the handle and outer glass facing down.

4. To remove the switch actuators:

- a) Remove the two inner door frame screws.

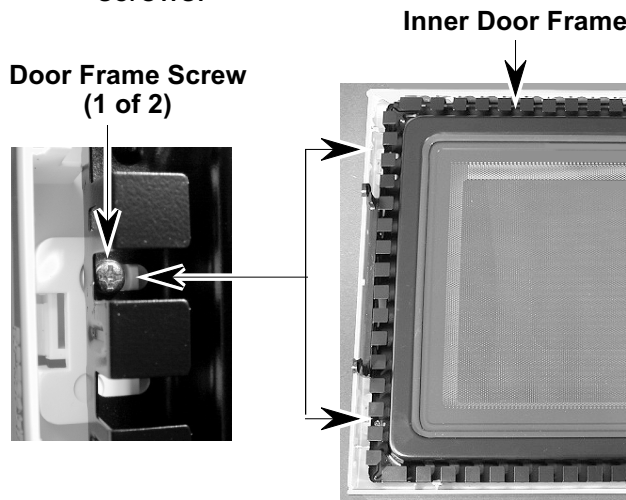

- b) Start at the lower right corner of the door and unclip the locking tabs along the bottom and right sides of the inner door frame while you lift the frame.
- c) When the inner door frame is free of the tabs, slide the frame out of the 3 top holders and remove it.

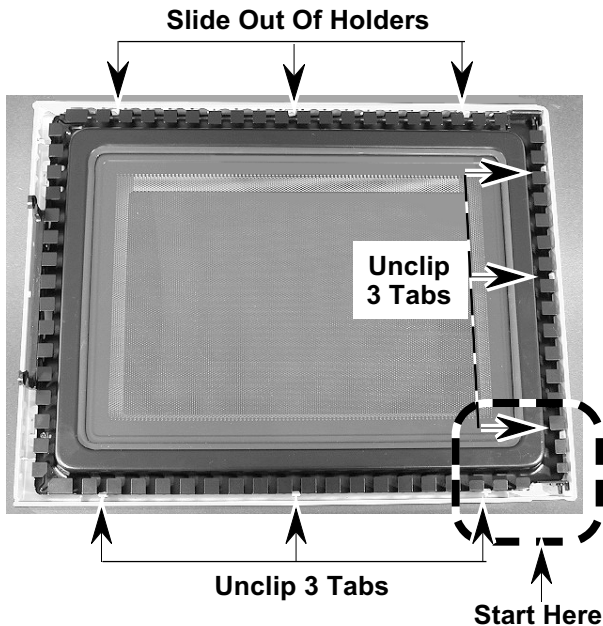

- d) Unhook the ends of the spring from the actuators.

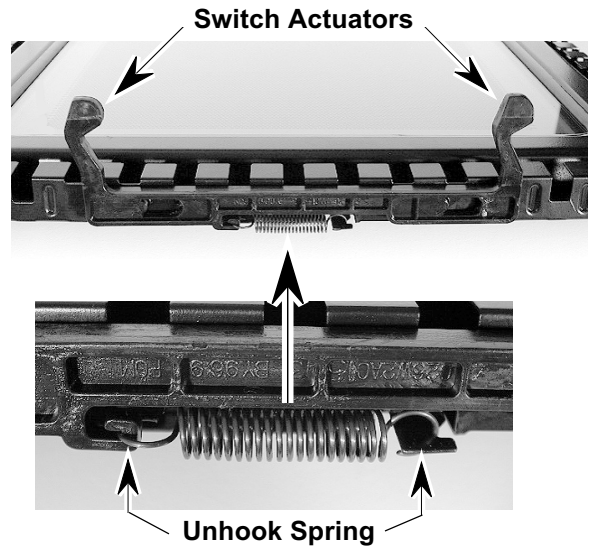

- e) Unhook the actuators from the slots in the inner door frame.

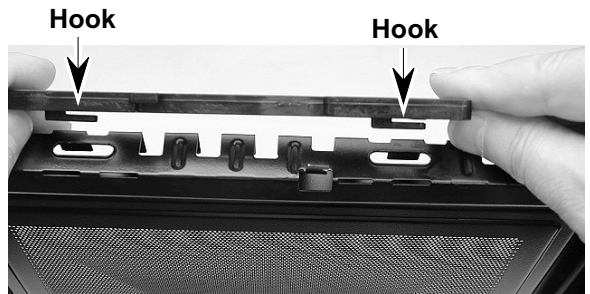

Continued on the next page.

5. **To remove the outer glass:**

- a) Use a screwdriver and push the 10 locking tabs (see the arrows below) back so they are not over the glass.

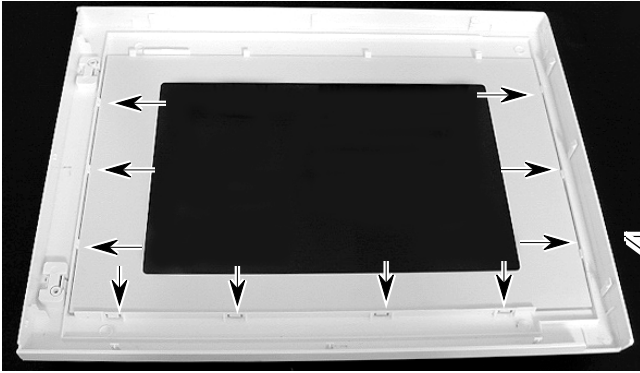

Outer Glass →

Tab Over Outer Glass

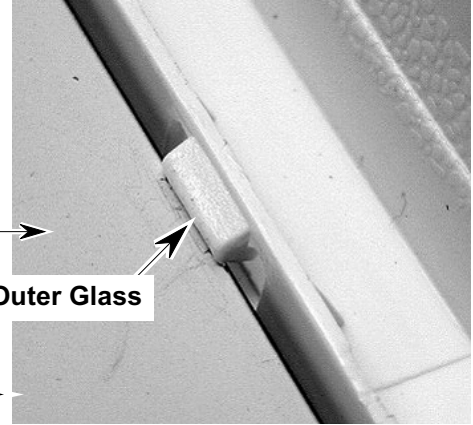

- b) Lift the glass and remove it from the door frame.

Tab Pushed Back

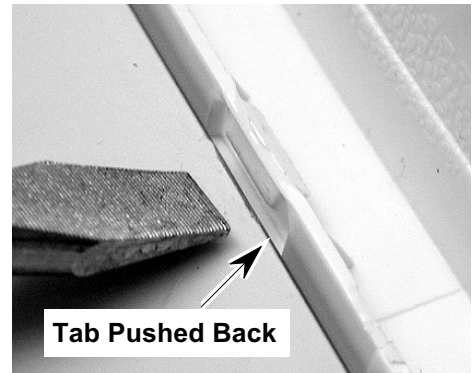

COMPONENT TESTING

Before testing any of the components, perform the following checks:

- Disconnect the power supply cord from the outlet before removing the outer cabinet from the unit.
- Discharge the high voltage capacitor and remove the wires from the primary winding of the high voltage transformer before conducting any of the high voltage component tests.
- Perform a microwave energy test after completing any repairs to the microwave.
- Make sure that all wires are properly connected before operating the microwave oven.
- Grasp the wires by their connectors when removing them from the microwave component terminals.

TOUCH PANEL CONTINUITY

WARNING

ELECTRICAL SHOCK HAZARD

Disconnect power before servicing.
Replace all panels before operating.
Failure to do so could result in death or electrical shock.

To test the touch panel, perform the following steps:

1. Disconnect the electrical power to the microwave oven.
2. Disconnect the ribbon cable from the control board connector.

3. Set the ohmmeter to the R x 100 scale.
4. Use a pair of alligator clips and clip them to the ribbon contact numbers shown along the top and side of the indicated keyboard matrix, shown below.

For example:

- a) Install alligator clips over contacts 5 and 8 of the ribbon cable.
- b) Touch the alligator clips with the test leads.
- c) Press the Cook Time keypad. The meter should indicate a resistance of less than 1000 Ω.

IMPORTANT: Make sure that the alligator clips make positive contact with the contact areas on the ribbon cable.

Flex Circuit Connector

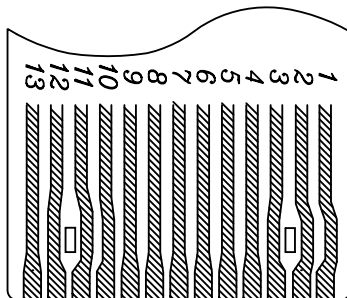

MH6140XK/6141XK

	1	2	3	4	5	6	7
8	VENT FAN HIGH/LOW/OFF	N.C.	COOK	POPCORN	COOK TIME	5	0
9	LIGHT ON/NIGHT/OFF	N.C.	REHEAT	BAKED POTATO	DEFROST	6	1
10	N.C.	CLOCK	ADD MINUTE	BEVERAGE	TIMER SET	7	2
11	N.C.	N.C.	N.C.	PIZZA	COOK POWER	8	3
12	N.C.	OFF CANCEL	START ENTER	TIMER OFF	HOLD WARM	9	4
13	N.C.	N.C.	FROZEN ENTREE	N.C.	N.C.	N.C.	N.C.

MHE14XK

	1	2	3	4	5	6	7
8	VENT FAN HIGH/LOW/OFF	N.C.	N.C.	POPCORN	COOK TIME	5	0
9	LIGHT ON/NIGHT/OFF	N.C.	REHEAT	N.C.	DEFROST	6	1
10	N.C.	CLOCK	N.C.	N.C.	N.C.	7	2
11	N.C.	N.C.	N.C.	N.C.	COOK POWER	8	3
12	N.C.	OFF CANCEL	START ENTER	N.C.	N.C.	9	4
13	N.C.	N.C.	N.C.	N.C.	N.C.	N.C.	N.C.

THE TURNTABLE & VENT MOTORS

! WARNING

ELECTRICAL SHOCK HAZARD

Disconnect power before servicing.
Replace all panels before operating.
Failure to do so could result in death or electrical shock.

TURNTABLE MOTOR

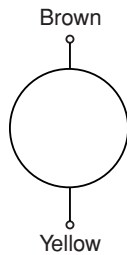

Refer to page 3-2 for the procedure for servicing the turntable motor.

1. Disconnect the electrical power to the microwave oven.
2. Disconnect the wires from the turntable motor terminals.
3. Set the ohmmeter to the R x 1K scale.
4. Touch the ohmmeter leads to the motor terminals. The meter should indicate between 2500 and 3500 Ω .

! WARNING

ELECTRICAL SHOCK HAZARD

Disconnect power before servicing.
Replace all panels before operating.
Failure to do so could result in death or electrical shock.

VENT MOTOR

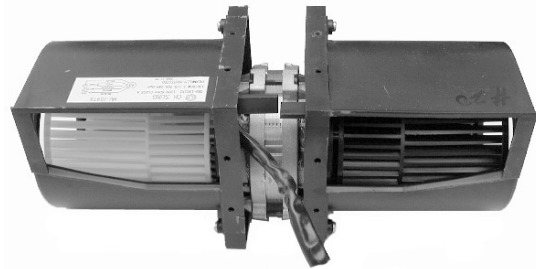

Refer to page 3-13 for the procedure for servicing the vent motor.

1. Disconnect the electrical power to the microwave oven.
2. Disconnect the vent motor wires from the control board.
3. Set the ohmmeter to the R x 1 scale.
4. Touch the ohmmeter leads to the indicated vent motor power plug wire connectors. The meter should indicate the following readings:
Black to white (Low) = 115 to 125 Ω .
Blue to black (High) = 60 to 75 Ω .

THE VENT MOTOR CAPACITOR, LINE FUSE, OVEN THERMOSTAT, & DOOR SWITCH

⚠️ WARNING

ELECTRICAL SHOCK HAZARD

Disconnect power before servicing.
Replace all panels before operating.
Failure to do so could result in death or electrical shock.

Refer to page 3-10 for the procedure for servicing the vent motor capacitor, page 3-8 for the line fuse and oven thermostat, and page 3-6 for the door switches.

1. Disconnect the electrical power to the microwave oven.
2. Set the ohmmeter to the R x 1 scale.
3. **To test the vent motor capacitor:**
 - a) Disconnect the vent motor power connector from the main harness connector.
 - b) Touch the ohmmeter leads to the main harness connector with the yellow (pin 6) and white (pin 3) wires. The meter should indicate several ohms and gradually return to infinity.

Vent Motor Capacitor

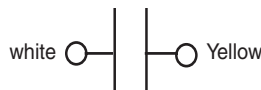
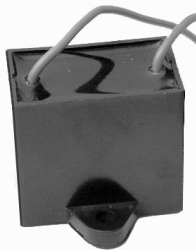

4. **To test the 20A line fuse,** touch the ohmmeter leads to the ends of the fuse. The meter should indicate continuity.

Line Fuse



5. **To test the oven thermostat:**
 - a) Disconnect the wires from the terminals.
 - b) Touch the ohmmeter leads to the terminals.
 - c) When the thermostat is open, (opens @ 194°F / 90°C), the meter will indicate infinity across the terminals.
 - d) When the thermostat is closed, the meter will indicate continuity.

Oven Thermostat

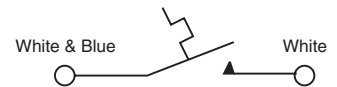

6. **To test the door switches:**
 - a) Disconnect the wires from the terminals.
 - b) Touch the ohmmeter leads to the terminals of the **primary** or **secondary** interlock switches (normally-open). The meter should indicate an open circuit (infinite).
 - c) Touch the ohmmeter leads to the terminals of the **monitor** switch (normally-closed). The meter should indicate a closed circuit (0 Ω).

NOTE: Pressing the actuator button should result in opposite readings (normally-open should read closed, and normally-closed should read open).

Door Switch

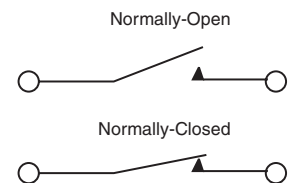

THE HIGH VOLTAGE CAPACITOR & RECTIFIER (DIODE)

! WARNING

ELECTRICAL SHOCK HAZARD

Disconnect power before servicing.
Replace all panels before operating.
Failure to do so could result in death or electrical shock.

Refer to page 3-10 for the procedure for servicing the high voltage capacitor and rectifier.

1. Disconnect the electrical power to the microwave oven.
2. Disconnect the rectifier and wire leads from the high voltage capacitor.
3. **To test the high voltage capacitor:**
 - a) Set the ohmmeter to the R x 1K scale.
 - b) Touch the ohmmeter leads to the capacitor terminals. The meter should indicate several ohms, and gradually return to infinity.
 - c) Touch one ohmmeter lead to the capacitor case. Touch the other lead to each of the terminals. The meter should indicate infinity at both terminals.

High Voltage Capacitor

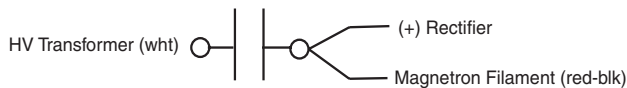
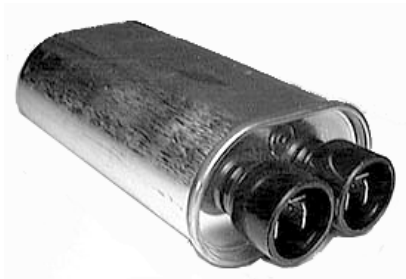

4. To test the high voltage rectifier:

- a) Set the ohmmeter to the R x 1K scale.
- b) Touch the positive ohmmeter lead to the anode lead of the rectifier and the negative ohmmeter lead to the cathode lead. The meter should indicate infinity.
- c) Reverse the ohmmeter leads on the rectifier and the meter should indicate infinity.

NOTE: If the meter reads below 100 Ω in either direction, the rectifier is defective and should be replaced.

High Voltage Rectifier

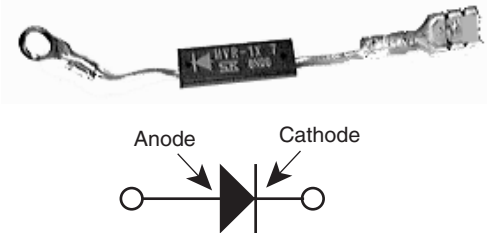

THE HIGH VOLTAGE TRANSFORMER

! WARNING

ELECTRICAL SHOCK HAZARD

Disconnect power before servicing.
Replace all panels before operating.
Failure to do so could result in death or electrical shock.

Refer to page 3-11 for the procedure for servicing the high voltage transformer.

1. Disconnect the electrical power to the microwave oven.
2. Disconnect the high voltage transformer wires from the magnetron and high voltage capacitor terminals.
3. Set the ohmmeter to the R x 1 scale.
4. Touch the ohmmeter leads to the two primary terminals. The meter should indicate less than 1 Ω .
5. Touch one ohmmeter lead to the white secondary wire terminal and the other lead to the transformer chassis ground lug. The meter should indicate between 65 and 120 Ω .
6. Touch the ohmmeter leads to the two red-black filament terminals. The meter should indicate 0 Ω .
7. Set the ohmmeter to the R x 1K scale.
8. Touch one ohmmeter lead to the transformer chassis ground lug. Touch the other lead to each of the filament terminals. The meter should indicate infinity at both terminals.

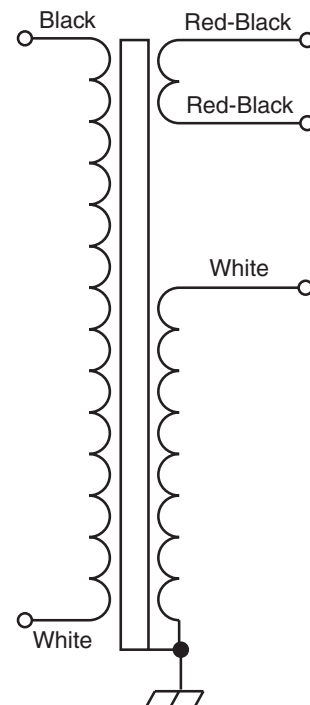
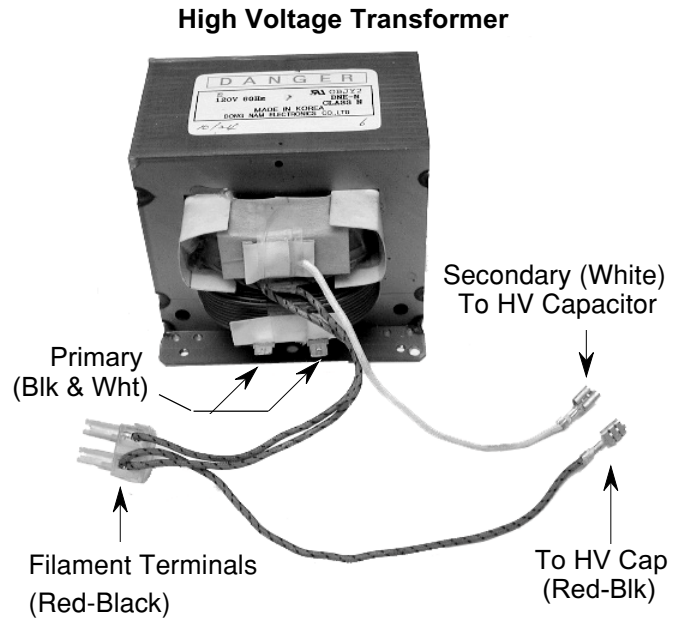

THE MAGNETRON

! WARNING

ELECTRICAL SHOCK HAZARD

Disconnect power before servicing.
Replace all panels before operating.
Failure to do so could result in death or electrical shock.

Refer to page 3-12 for the procedure for servicing the magnetron.

1. Disconnect the electrical power to the microwave oven.
2. Disconnect the wire connectors from the filament terminals.
3. Set the ohmmeter to the R x 1 scale.
4. Touch the ohmmeter leads to the filament terminals. The meter should indicate less than 1 Ω .
5. Set the ohmmeter to the R x 1K scale.
6. Touch one ohmmeter lead to the magnetron case. Touch the other lead to each of the filament terminals. The meter should indicate infinity at both terminals.

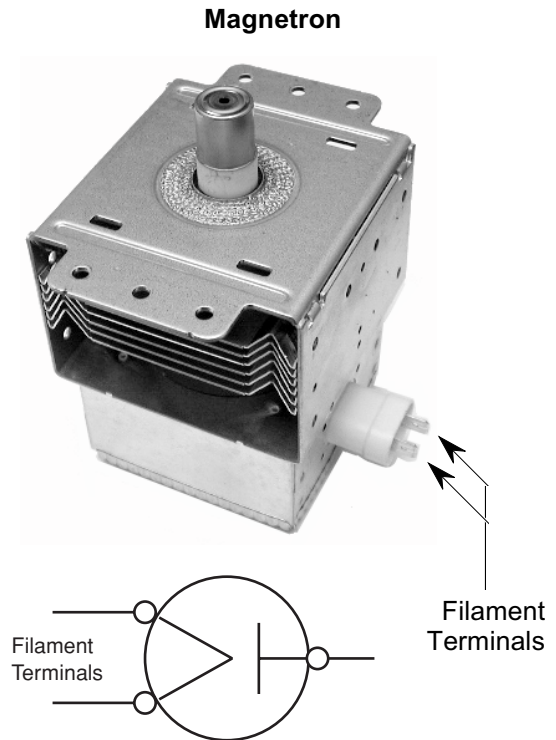

WIRING DIAGRAM & STRIP CIRCUITS

WIRING DIAGRAM

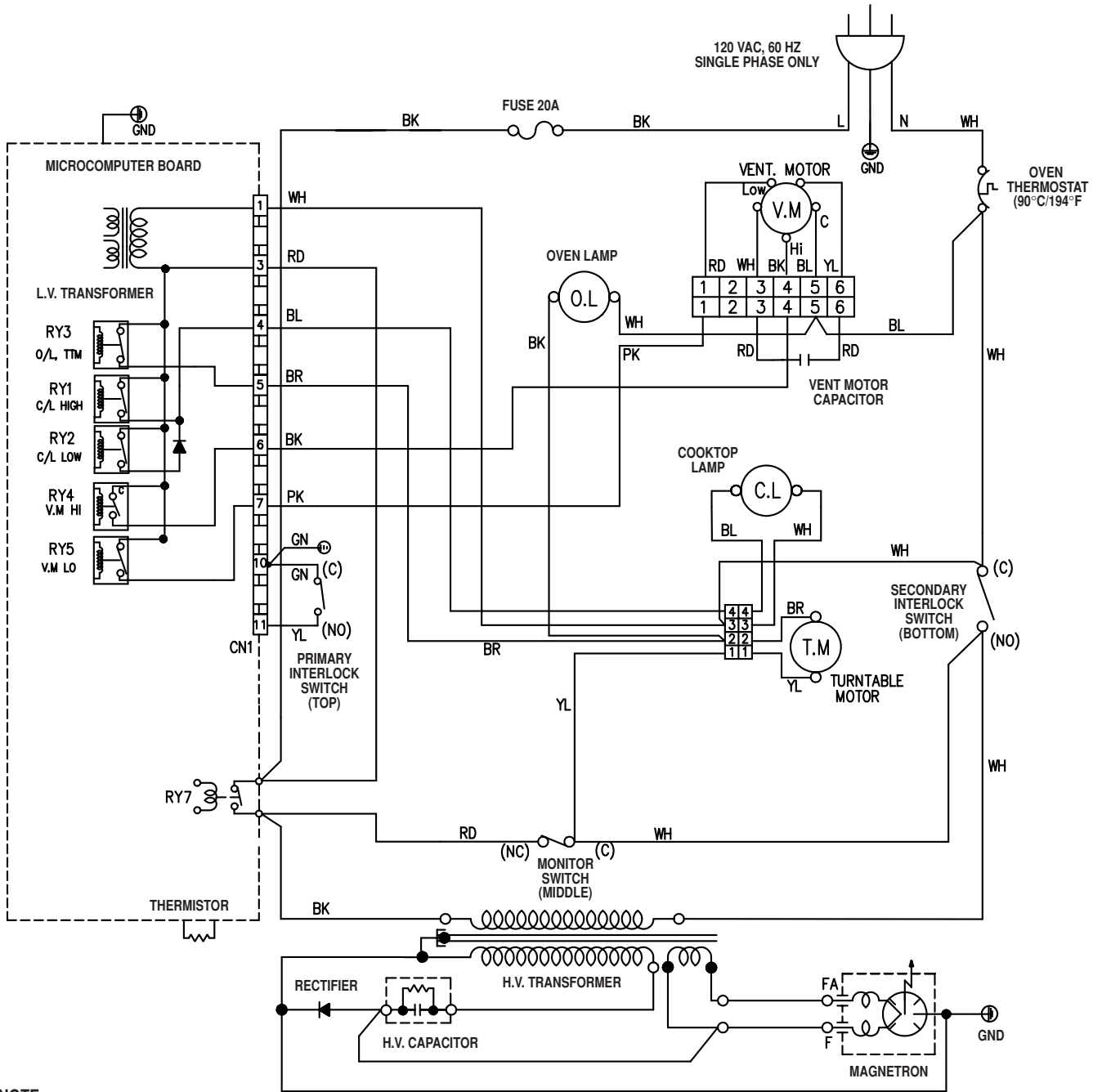

NOTE:

1. DOOR OPENED & COOK OFF MODE.

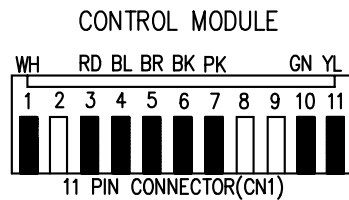

WIRE COLORS

SYMBOL	COLOR
WH	WHITE
BK	BLACK
RD	RED
YL	YELLOW
PK	PINK
BL	BLUE
BR	BROWN
GN	GREEN
GY	GREY

STRIP CIRCUITS

UNIT IS PLUGGED IN - CLOCK IS WORKING

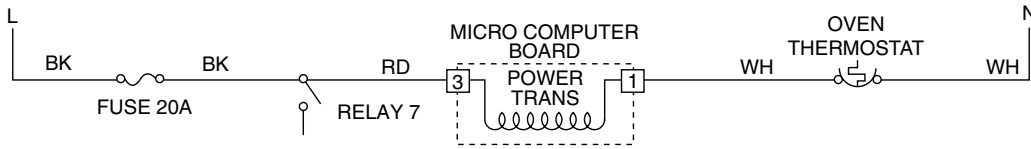

DOOR IS OPEN - OVEN LAMP IS ON

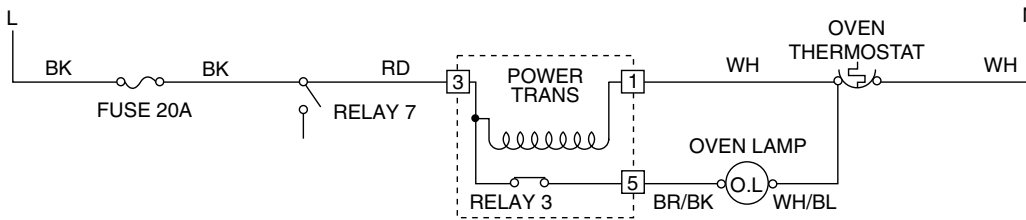

VENT MOTOR IS ON "LOW"

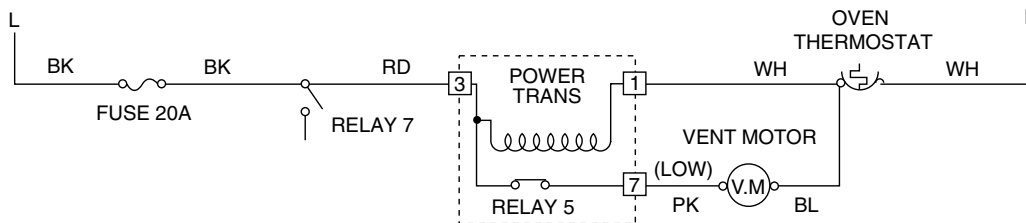

VENT MOTOR IS ON "HIGH"

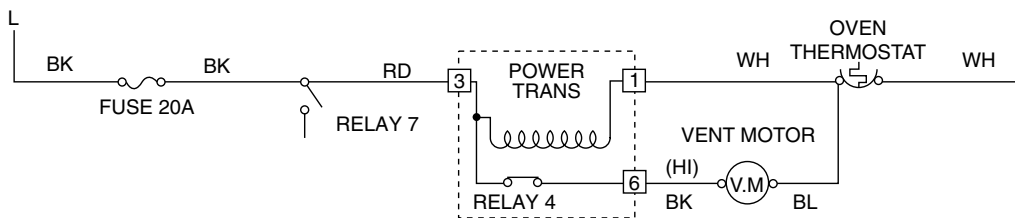

VENT MOTOR IS ON "HIGH" AUTOMATICALLY

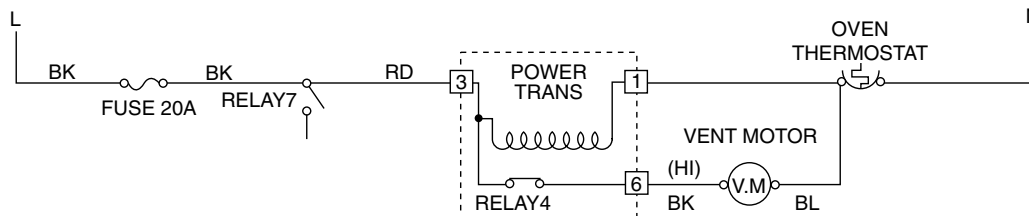

TURNTABLE MOTOR IS ON

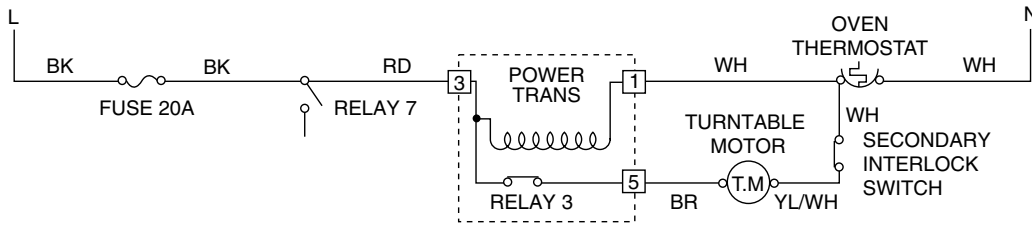

COOKTOP LAMPS ARE ON "HIGH" OR "LOW"

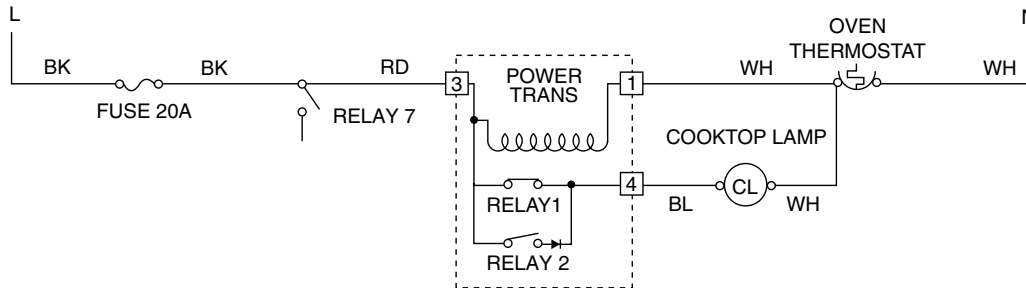

MICROWAVE COOKING IS ON

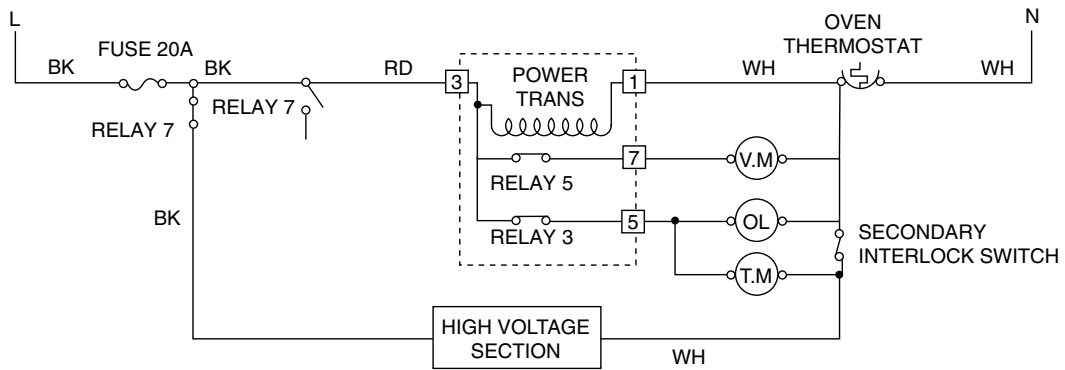

— NOTES —

PRODUCT SPECIFICATIONS AND WARRANTY INFORMATION SOURCES

IN THE UNITED STATES:

FOR PRODUCT SPECIFICATIONS AND WARRANTY INFORMATION CALL:

FOR WHIRLPOOL PRODUCTS: 1-800-253-1301
FOR KITCHENAID PRODUCTS: 1-800-422-1230
FOR ROPER PRODUCTS: 1-800-447-6737

FOR TECHNICAL ASSISTANCE WHILE AT THE CUSTOMER'S HOME CALL:

THE TECHNICAL ASSISTANCE LINE: 1-800-253-2870

**HAVE YOUR STORE NUMBER READY TO IDENTIFY YOU AS AN
AUTHORIZED SERVICER**

FOR LITERATURE ORDERS:

PHONE: 1-800-851-4605

IN CANADA:

FOR PRODUCT SPECIFICATIONS AND WARRANTY INFORMATION CALL:

1-800-461-5681

FOR TECHNICAL ASSISTANCE WHILE AT THE CUSTOMER'S HOME CALL:

THE TECHNICAL ASSISTANCE LINE: 1-800-488-4791

**HAVE YOUR STORE NUMBER READY TO IDENTIFY YOU AS AN
AUTHORIZED SERVICER**

