

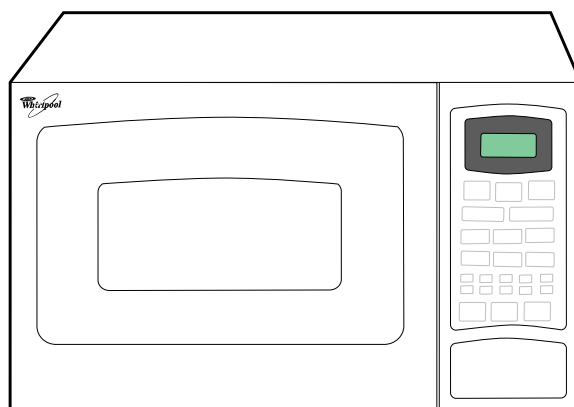

Service Professional Seminar



MICROWAVE OVENS

WARNING

Electrical Shock Hazard

Disconnect the microwave oven line cord plug from the wall receptacle before you service any of the components inside the unit. Failure to do this could result in violent electrical shock.

VOLTAGE CHECKS

When making voltage checks, be sure to observe the following precautions:

1. The floor must be dry. Water and dampness increase the chances of electrical shock.
2. Set the voltmeter correctly for the voltage being measured.
3. Touch only the insulated parts of the meter probes.
4. Touch the component terminals, or wires, with the meter probe tips only.
5. Touch the meter probe tips only on the terminals being checked. Touching other components could damage good parts.

PARTS QUALITY

An important step in the appliance repair procedure is the selection of FSP® (FACTORY SPECIFICATION PARTS) as replacements. Use of “fits-all,” or “look alike” parts could result in early parts failure, safety hazard, or substandard performance of a WHIRLPOOL appliance. It could also result in an unnecessary repeat of your repair efforts.

To be sure that the part(s) you purchase meet the exacting quality standards used to build every new WHIRLPOOL appliance, be sure to ask for genuine FSP replacement parts, as specified for your model. “FSP” is a registered trademark of WHIRLPOOL CORPORATION.

You can buy your genuine FSP replacement parts from any authorized WHIRLPOOL Parts Distributor.

WHIRLPOOL CORPORATION assumes no responsibility for any repair made on our products by anyone other than qualified TECH-CARE® Service Technicians.

Table Of Contents

Section 1
Theory Of Microwave Cooking Page 1

Section 2
Major Component Locations Page 7

Section 3
Component Access & Testing Page 10
 Safety Information Page 10

Section 4
Theory Of Operation Page 28

Section 5
Diagnostics Page 34

INTRODUCTION

This program is designed to teach the servicer basic skills in handling common service procedures for microwave ovens. This program does not cover the diagnosis and repair of all problems and components.

PROGRAM OBJECTIVE

Upon completion of this program, the participants will be able to identify the location of major microwave oven components, as well as diagnose problems, and remove and repair the components causing the problem.

INSTRUCTIONS

This program has the following sections:

- Theory Of Microwave Cooking
- Major Component Locations
- Component Access & Testing
- Theory Of Operation
- Diagnostics

Complete the “Major Component Locations” section, and have the instructor review the “Performance Check” before continuing. If you have any questions, ask your instructor.

TOOLS YOU WILL NEED

Needle-Nose Pliers

8mm Metric Socket

Phillips Screwdriver

Adjustable Wrench

Special Tools:

- Volt-Ohmmeter

– Section 1 –

THEORY OF MICROWAVE COOKING

Cooking with microwaves has transformed modern food preparation technology. With the introduction of the microwave oven in the mid 1970s, food preparation has become more efficient and convenient. It generally takes less time to cook food by microwaves than by conventional methods, and microwave ovens consume much less energy.

MICROWAVE COOKING

Microwave cooking is accomplished by penetrating food with high frequency electromagnetic waves, called **microwaves**. Microwaves have the unique characteristic of:

- Reflecting off metals.
- Passing through most glass, paper and plastics.
- Being absorbed by foods containing fats and liquids.

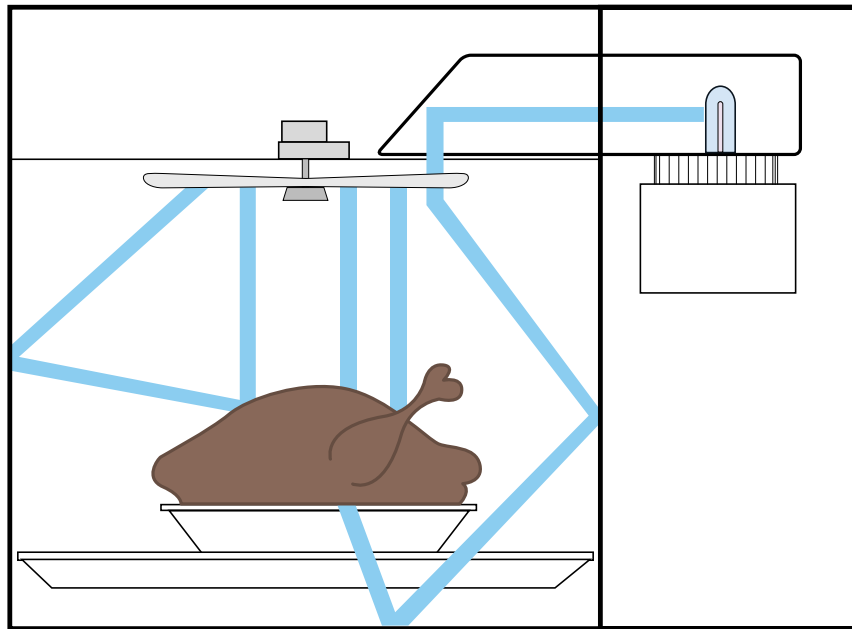

In conventional ovens, first an element is heated. Then the surrounding air is heated, followed by the walls, the racks and the pan. Finally the surface of the food is heated, and this heat is conducted from the surface to the interior to cook the food.

Microwave cooking differs from conventional cooking in that heat is produced instantly in food as it absorbs microwave energy. Cooking heat is produced in the food rather than externally.

In microwave cooking, the greater penetration of the microwaves will instantly affect molecules in and below the surface of the food. These molecules are stimulated by the microwaves much the same as magnets are affected by an electromagnetic field. The molecules oscillate with the microwaves as they penetrate the food.

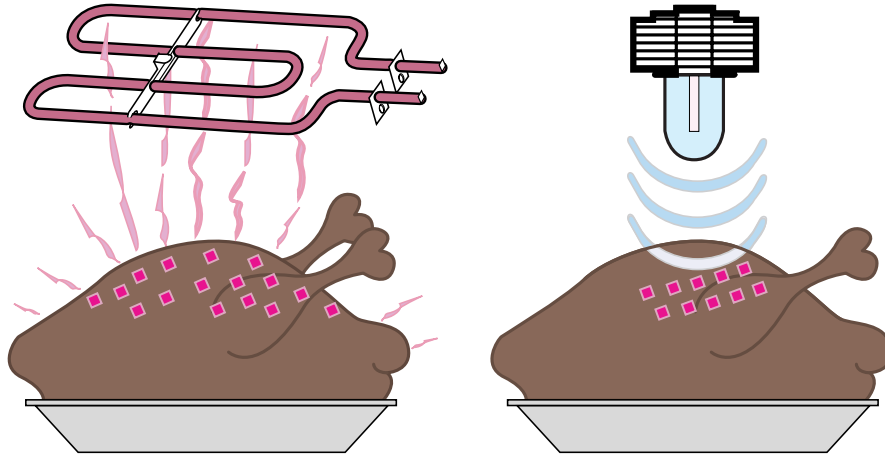

Microwaves oscillate, or change polarity from positive to negative, at 4900 million times-per-second. Since water and fat molecules within food contain positive and negative charges, exposing the food molecules to a microwave field causes the molecules to align themselves with the microwave energy. Each time the microwave energy changes polarity, the molecules again try to align themselves with the field. Thus, by oscillating the molecules 4900 million times-per-second, (2450 Megahertz), tremendous friction is created producing the intense heat necessary for rapid cooking.

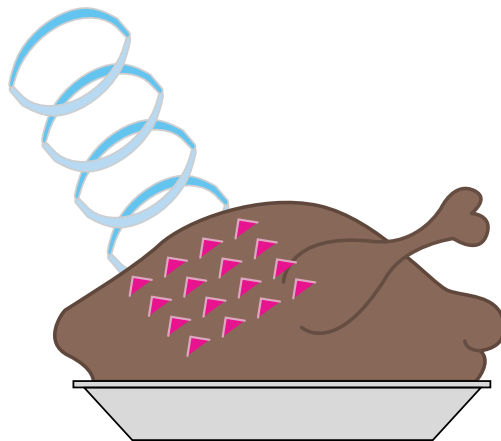

All of the heat is produced inside the first 3/4" to 2" of the foods surface.

If the food is thicker than 2", the heat will continue to conduct itself through the food to complete the cooking process. Some microwave cooking instructions say that the food should "stand" for a period of time after being removed from the oven so the internally-produced heat has time to be conducted throughout the food.

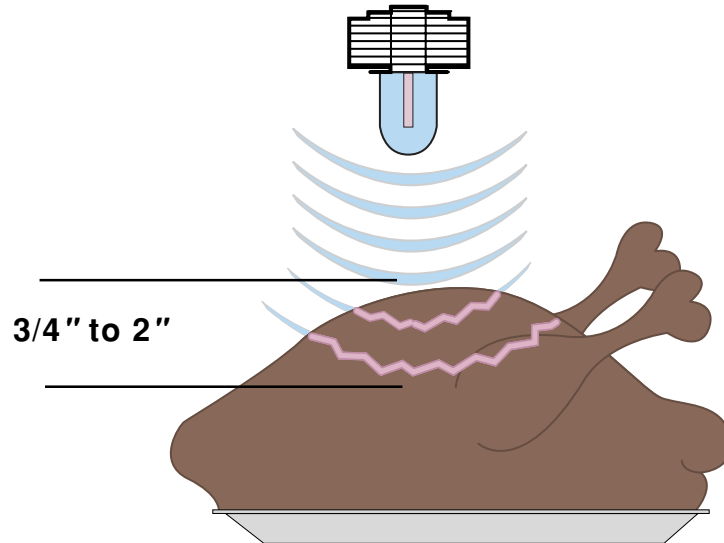

ELECTROMAGNETIC ENERGY AND MICROWAVES

Microwaves are ***ultra-high-frequency electromagnetic waves***, not heat waves. An electromagnetic wave is energy that travels at the speed of light in organized and measurable waves, or cycles, and creates electromagnetic fields.

Depending on the frequency of the wave, the energy that is produced can be used in a number of applications. Radio and television signals are electromagnetic waves. Visible light, as well as infrared and ultra-violet light are also electromagnetic waves. In addition to cooking, microwaves are also used to transmit data, voice, radio, and television across long distances on land or to and from satellites orbiting the earth.

Electromagnetic waves are classified in an ***electromagnetic spectrum*** according to ***wavelength*** and ***frequency***. In the United States the use of the electromagnetic spectrum is regulated by the Federal Communications Commission. The following chart shows the classification of electromagnetic waves.

CLASSIFICATION OF ELECTROMAGNETIC WAVES			
BAND		FREQUENCY	WAVELENGTH
VLF (Very Low Frequency)		10 kHz	100 - 10 Km
LF (Low Frequency)		100 kHz	1 Km
MF (Medium Frequency)		1 MHz	100 m
HF (High Frequency)	Local Police Radio	10 MHz	10 m
VHF (Very High Frequency)	Television	100 MHz	1 m
UHF (Ultra High Frequency)	<i>MICROWAVE OVENS</i>	1000 MHz	10 cm
SHF (Super High Frequency)	Garage Door Openers	10 ⁴ MHz	1 cm
EHF (Extremely High Frequency)		10 ⁵ MHz	1 mm
Infrared		10 ⁶ MHz	10 ⁻³ mm
Visible/Ultra-Violet Light		10 ⁹ MHz	10 ⁻⁶ mm
X-Ray/Gamma Ray		10 ¹² MHz	10 ⁻⁹ mm

Browning of meats and other foods is not as noticeable as with conventional cooking, although roasts, turkeys and other bulkier meats requiring a longer cooking time brown just as in conventional cooking.

Now that we know how food cooks in a microwave oven, what is a microwave? What does a microwave look like? If we could see a microwave, it is about 4.8 inches long, and about the thickness of a pencil.

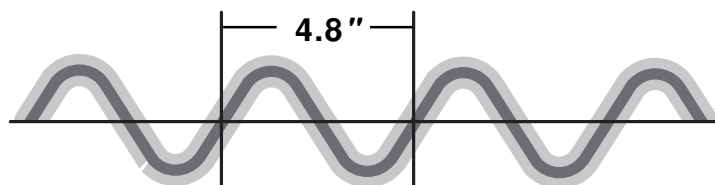

By the formula C (Speed of Light) / F (Frequency) = W (Wavelength) we can determine the wavelength of cooking microwaves at approximately 12 cm or 4.8 inches.

$$\frac{300,000 \text{ Km/sec. (Speed of Light)}}{2,450 \text{ MHz (Frequency)}} = 12.2 \text{ cm (Wavelength)}$$

The ultra high frequency of 2,450 MHz has been assigned to microwave ovens. MHz or Mega Hertz means a million cycles per second.

One characteristic of microwaves is important to note here. The only effect microwaves have on fat and water is to cause the molecules to move rapidly. Microwaves do not cause any changes to the molecule's structure, or its genetic contents.

Forms of wave energy with frequencies up through visible light, are called **nonionizing energy**. Nonionizing energy does not change cellular, or genetic structure, and does not accumulate in tissue after repeated exposure. Microwaves are within this group of electromagnetic waves, and are said to be "nonionizing."

By contrast, energy waves with extremely high frequencies and short wavelengths, are considered **ionizing energy**. Exposure to ionizing energy, such as X-rays, gamma, or cosmic rays, can be damaging to living tissue, because these types of wave energy can change cellular and genetic structure. Ionizing energy also builds-up, or accumulates, after repeated exposure.

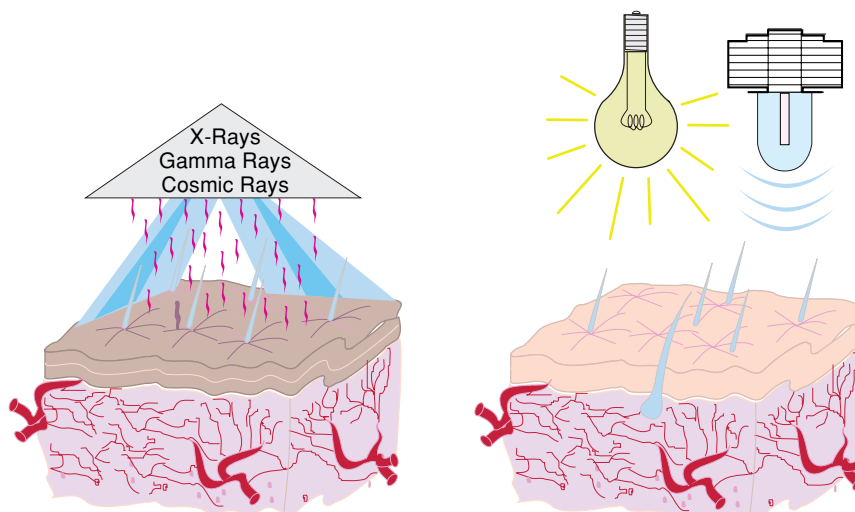

The effects of wave energy are dependent on the wavelength and relative strength, or amplitude, of the wave. Electromagnetic waves that are relatively strong at the source lose their strength in inverse proportion to the square of the distance from the source. Television transmissions in the thousands of watts at the source are only detectable by extremely sensitive electronic circuits, and they have no effect on people. In a similar manner, the energy level measured just 16 inches away from a microwave oven, would drop to just 1/256 of the energy level measured inside (at the source).

Because of the relatively high frequency and high energy level of microwaves, and the short distance between the source of the microwaves and the food confined in a properly operating microwave oven, the energy waves remain strong enough to cause the water and fat molecules in food to oscillate, or move, to align themselves with the positive and negative cycles of the microwaves. This vibration causes friction between the molecules, which in turn, causes heat to build up.

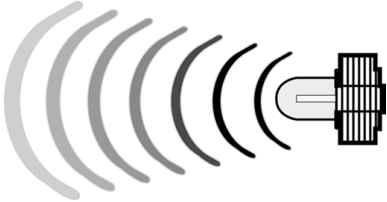

16	8	4	2	Inches
$\frac{E}{256}$	$\frac{E}{16}$	$\frac{E}{4}$	$\frac{E}{1}$	

– Section 2 –

MAJOR COMPONENT LOCATIONS

OBJECTIVE

To teach the technician how to identify the location of each major component in a microwave oven. These components are:

- Touch Panel
- Electronic Oven Control
- Technician Safety Switch
- Line Fuse & Thermal Fuses
- Door Switches
- Fan Motor
- High Voltage Power Transformer
- HV Capacitor & Rectifier (Diode)
- Magnetron
- Oven Door
- Turntable Motor

The illustration below shows the location of the major components in the microwave oven. Study the illustration until you feel that you can mark the location of these components on a drawing. When you are ready, proceed to the “Performance Check” on the next page.

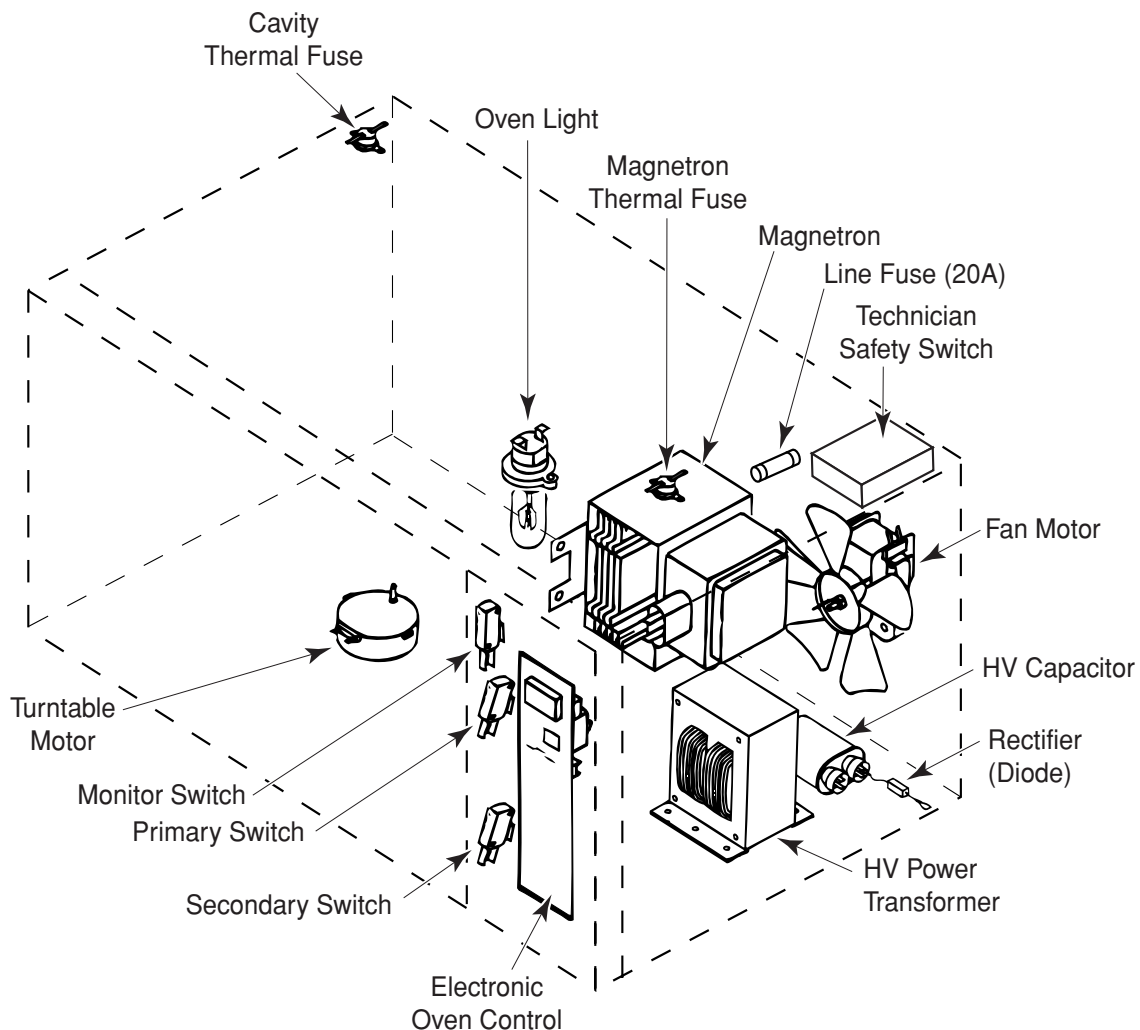

Performance Check

Locate the individual components in the illustration on the next page, and place the letter of each component name next to the arrow. Do not refer back to the example on page 7.

When you are finished, take the book to the instructor, and have the results recorded. After you are signed-off by the instructor, proceed to the next section.

You have four (4) minutes to complete this exercise.

- A. Electronic Oven Control
- B. Technician Safety Switch
- C. Line Fuse
- D. Cavity Thermal Fuse
- E. Magnetron Thermal Fuse
- F. Primary Switch
- G. Monitor Switch
- H. Secondary Switch

- J. Fan Motor
- K. Rectifier (Diode)
- L. HV Power Transformer
- M. HV Capacitor
- N. Magnetron
- P. Turntable Motor
- Q. Oven Light

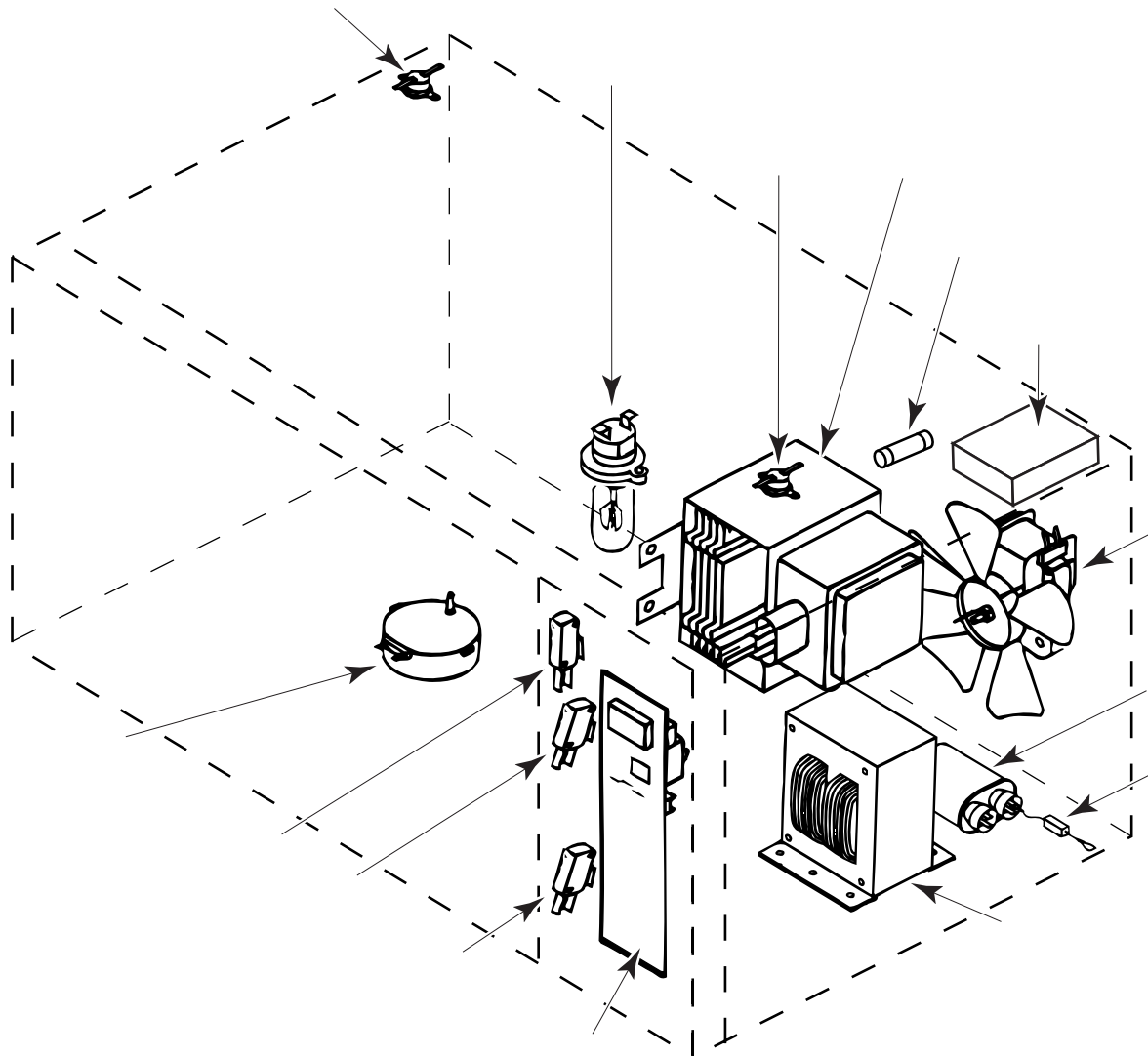

– Section 3 –

COMPONENT ACCESS & TESTING

SAFETY INFORMATION

KEEP YOUR WORK AREA SAFE

Four thousand volts of electricity is created within the high voltage system in the microwave oven. It is extremely important that you protect yourself, your equipment, and the product when you are servicing a microwave oven.

Whenever you remove the oven cabinet you must:

- Discharge the high voltage capacitor with a 20,000 ohm, (20 k Ω) (red-black-orange), 2-Watt resistor with insulated leads, by touching the lead ends to the terminals, as shown.

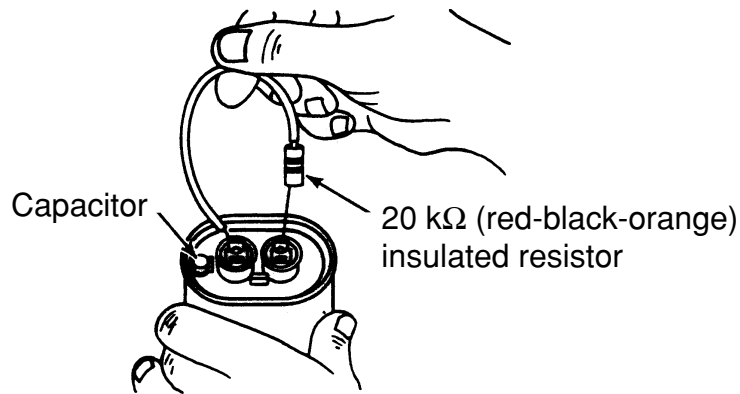

- Whenever possible, isolate the high voltage section of the oven by removing the black and red wires from the power transformer.

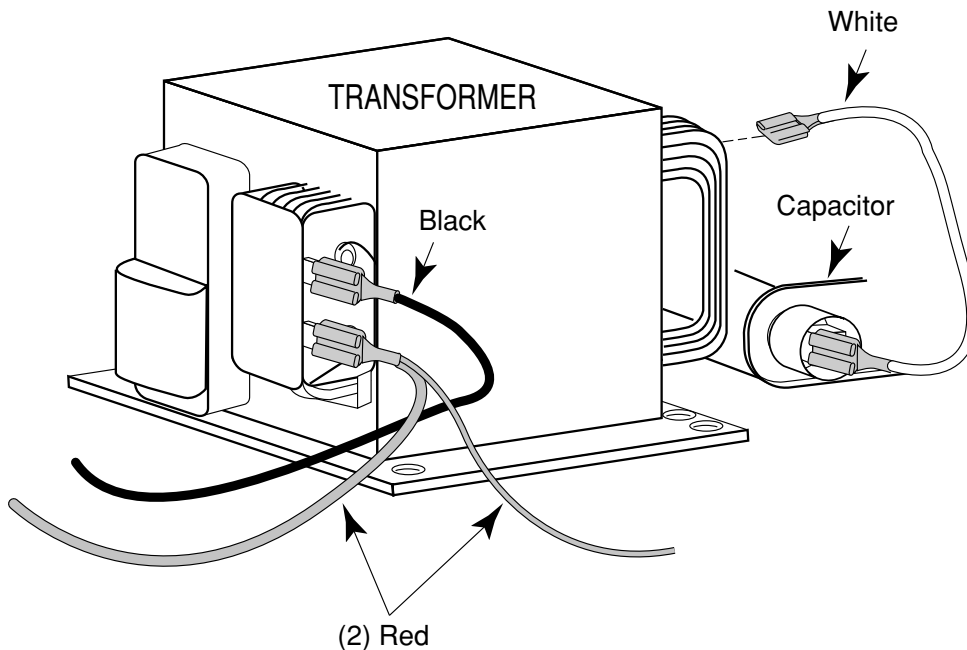

THE OPERATING CONTROL SYSTEM

REMOVING THE CABINET

1. Unplug the oven.

CAUTION: When you work on the microwave oven, be careful when handling the sheet metal parts. Sharp edges may be present and you can cut yourself if you are not careful.

2. Remove the six screws from the back of the oven.
3. Pull the cabinet back to disengage the location tabs from the slots.

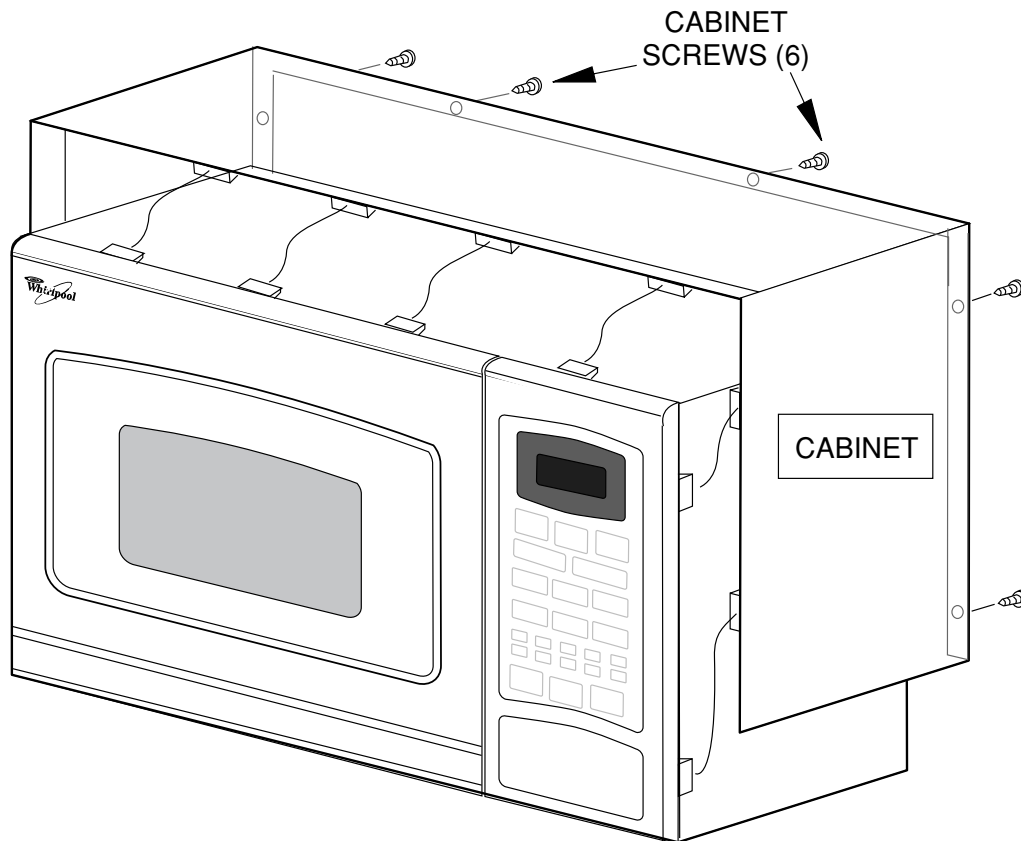

IMPORTANT NOTE: These units are manufactured with technician safety switches. This switch will disconnect the AC line voltage from the unit whenever the cabinet is removed. When servicing the unit with the cabinet removed, the safety switch must be bypassed.

TESTING THE ELECTRONIC OVEN CONTROL

1. Unplug the oven.
2. Remove the cabinet.
3. Discharge the HV capacitor with a 20,000 Ω , 2-Watt resistor.
4. Set the voltmeter to measure 120 volts AC.
5. Override the technician safety switch.
6. Disconnect the high voltage system by removing the black and red wires from the high voltage transformer.
7. Connect the voltmeter leads to the ends of the black and red wires that you just disconnected.
8. Plug the microwave oven into a 120 volt AC outlet.
9. Set the control panel as follows:
 - Cook Time for **1:00**.
 - Cook Power for 50% (keypad #5).
 - Press Start.
10. The voltmeter should indicate 120 volts AC, as indicated in the following chart.

POWER LEVEL	ON (SEC)	OFF (SEC)	POWER LEVEL	ON (SEC)	OFF (SEC)
1	4.0	19.0	6	15.2	7.8
2	6.2	16.8	7	17.3	5.7
3	8.5	14.5	8	19.5	3.5
4	10.8	12.2	9	21.2	1.8
5	13.0	10.0	10	23.0	0.0

REMOVING THE ELECTRONIC OVEN CONTROL

(Touch Panel & Microcomputer Board)

1. Unplug the oven.
2. Discharge the HV capacitor with a 20,000 Ω , 2-Watt resistor.
3. Remove the screw, lockwasher, and nut from the green ground wire eyelet (see the illustration at the top of the next page).
4. Unplug the wires and connectors from the electronic oven control board.
5. Remove the three mounting screws from the back of the control panel.

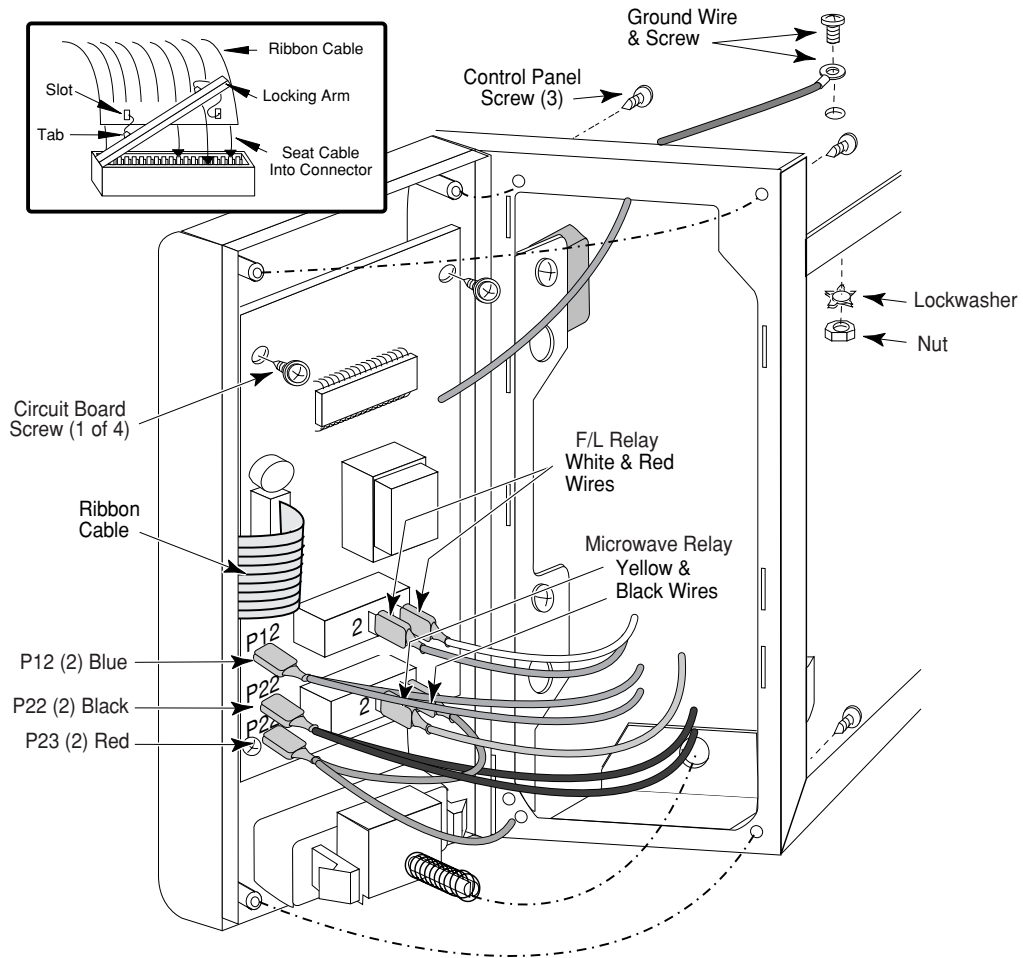

TESTING THE TOUCH PANEL

1. Remove the ribbon cable from its connector.
2. Measure the resistance between the terminal pins of the keypad (shown below) that you wish to check.

TOUCH PANEL CONTINUITY CHART								
1	—	—	START/ ENTER	ADD MINUTE	OFF/ CANCEL	POPCORN	DEFROST	REHEAT
2	—	—	6	8	0	VEGETABLES	9	7
3	—	—	1	3	5	4	BREAKFAST	2
4	—	—	COOK TIME	COOK POWER	CLOCK SET	FROZEN ENTREE	BEVERAGE	BAKED POTATOES
	12	11	10	9	8	7	6	5

Performance Check

1. Remove the shipping material from the microwave oven and install the turntable.
2. Use the Use and Care Guide and perform the following steps:
 - Set the Time-Of-Day.
 - Set the oven to Cook at 50% power for 2-minutes.
3. Have the instructor sign off your work.
4. Remove the microwave oven cabinet.
5. Discharge the HV capacitor with a 20,000 Ω , 2-Watt resistor.
6. Test the electronic oven control.
7. Remove the electronic oven control.
8. Test the touch panel.

THE PROTECTIVE CONTROL SYSTEM

The Protective Control System is designed to contain microwave energy within the oven and protect the consumer and the appliance. The system contains the following components:

- Technician Safety Switch
- Line and Thermal Fuses
- Oven Door Switches
- Fan Motor
- Turntable Motor
- Oven Door

REMOVING THE TECHNICIAN SAFETY SWITCH

1. Unplug the oven.
2. Remove the cabinet.
3. Discharge the HV capacitor with a 20,000 Ω , 2-Watt resistor.
4. Remove the flat-head screw from the rear panel.

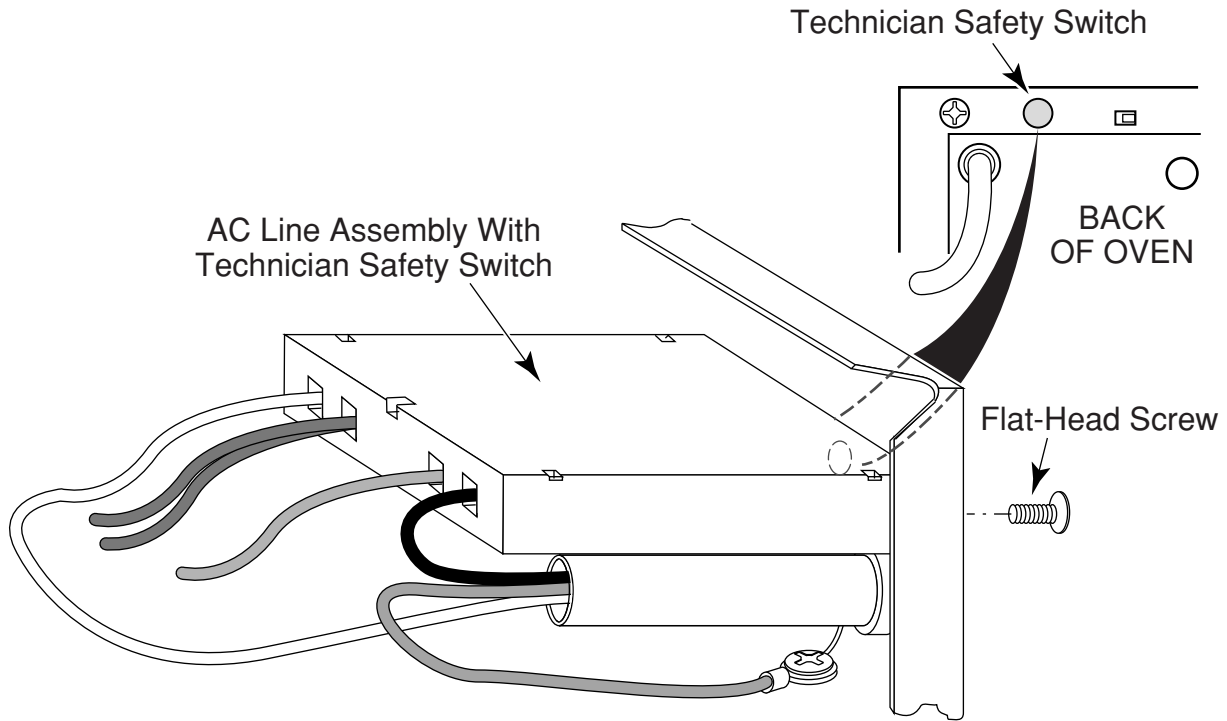

REMOVING THE LINE FUSE & THERMAL FUSES

1. Unplug the oven.
2. Remove the cabinet.
3. Discharge the HV capacitor with a 20,000 Ω , 2-Watt resistor.

Removing The Line Fuse (20A)

4. Locate the line fuse and remove it from the fuseholder.

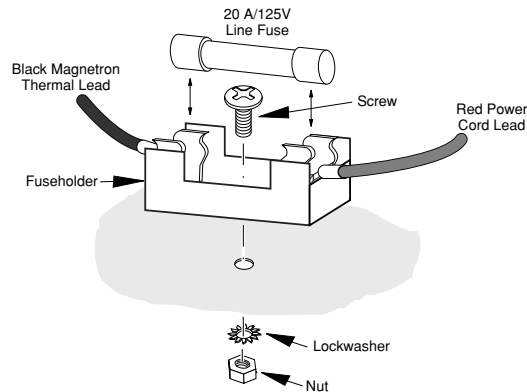

Removing A Thermal Fuse

5. Disconnect the wires from the thermal fuse terminals.
6. Remove the two mounting screws from the thermal fuse.

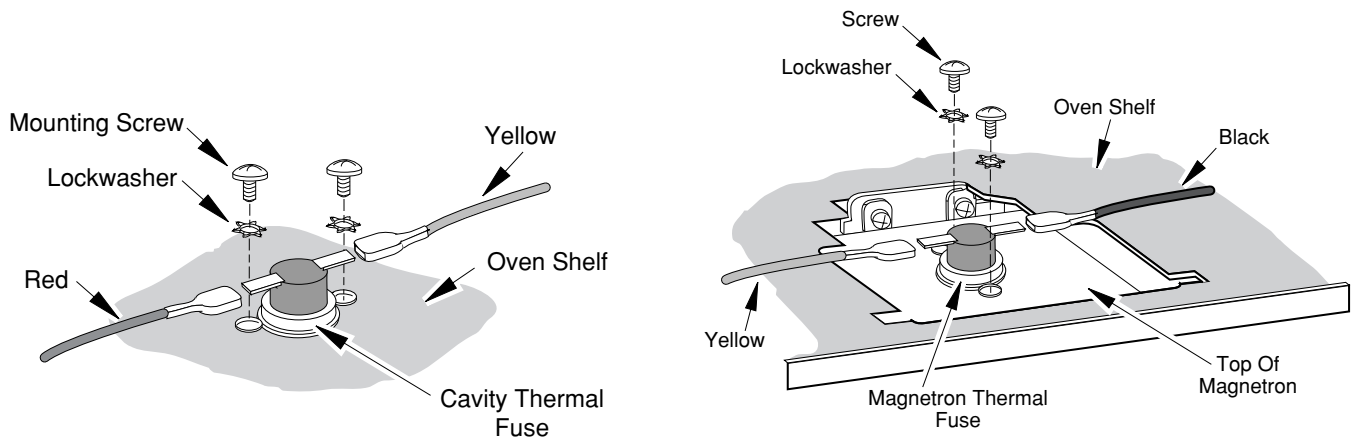

CAVITY THERMAL FUSE

Opens @ 176 °F — Resets A 92 °F

MAGNETRON THERMAL FUSE

Opens @ 293 °F — Resets A 127 °F

TESTING A FUSE

1. To test a fuse, set the ohmmeter to the R x 1 scale and check for continuity.

REMOVING THE OVEN DOOR SWITCHES

1. Unplug the oven.
2. Remove the cabinet.
3. Discharge the HV capacitor with a 20,000 Ω , 2-Watt resistor.
4. Remove the wiring from the switch you wish to test.
5. Remove the two screws from the switch mounting bracket.
6. Unsnap the switch from the mounting bracket.

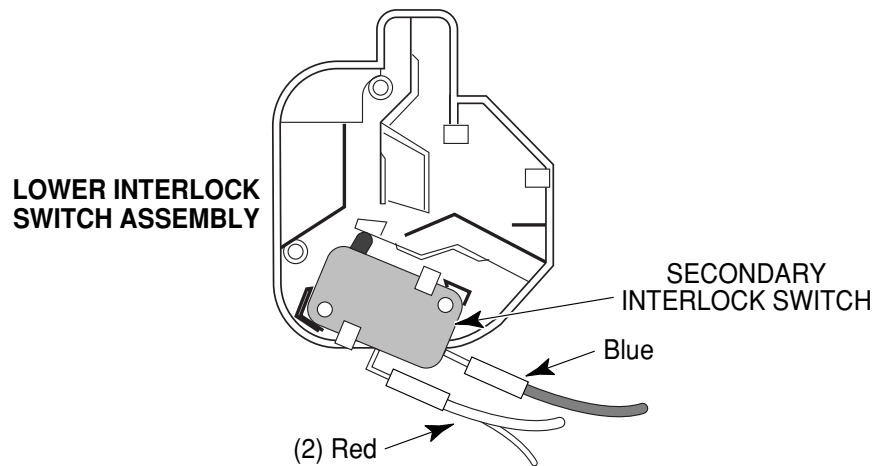
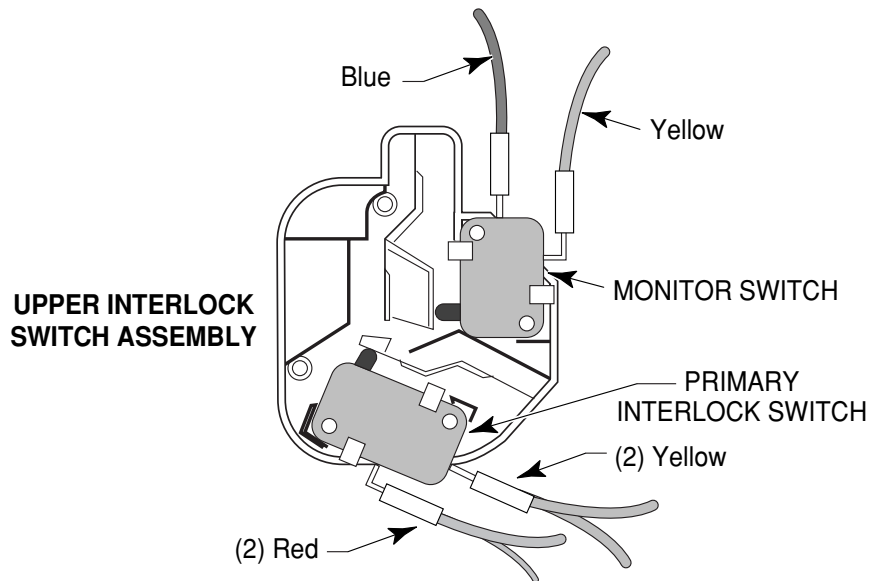

TESTING THE OVEN DOOR SWITCHES

NOTE: The Primary and Secondary switches are normally-open switches. The Monitor switch is a normally-closed switch. Test the switches accordingly.

REMOVING THE FAN MOTOR

1. Unplug the oven.
2. Remove the cabinet.
3. Discharge the high voltage capacitor using a 20,000 Ω , 2-Watt resistor.
4. Remove the wires from the fan motor terminals.
5. Remove the screws from the fan motor mounting plate and remove the fan motor assembly.
6. Remove the e-ring from the fan motor's D-shaft and pull the blade off the shaft. Be careful not to bend the fan blades or the motor mounting bracket.

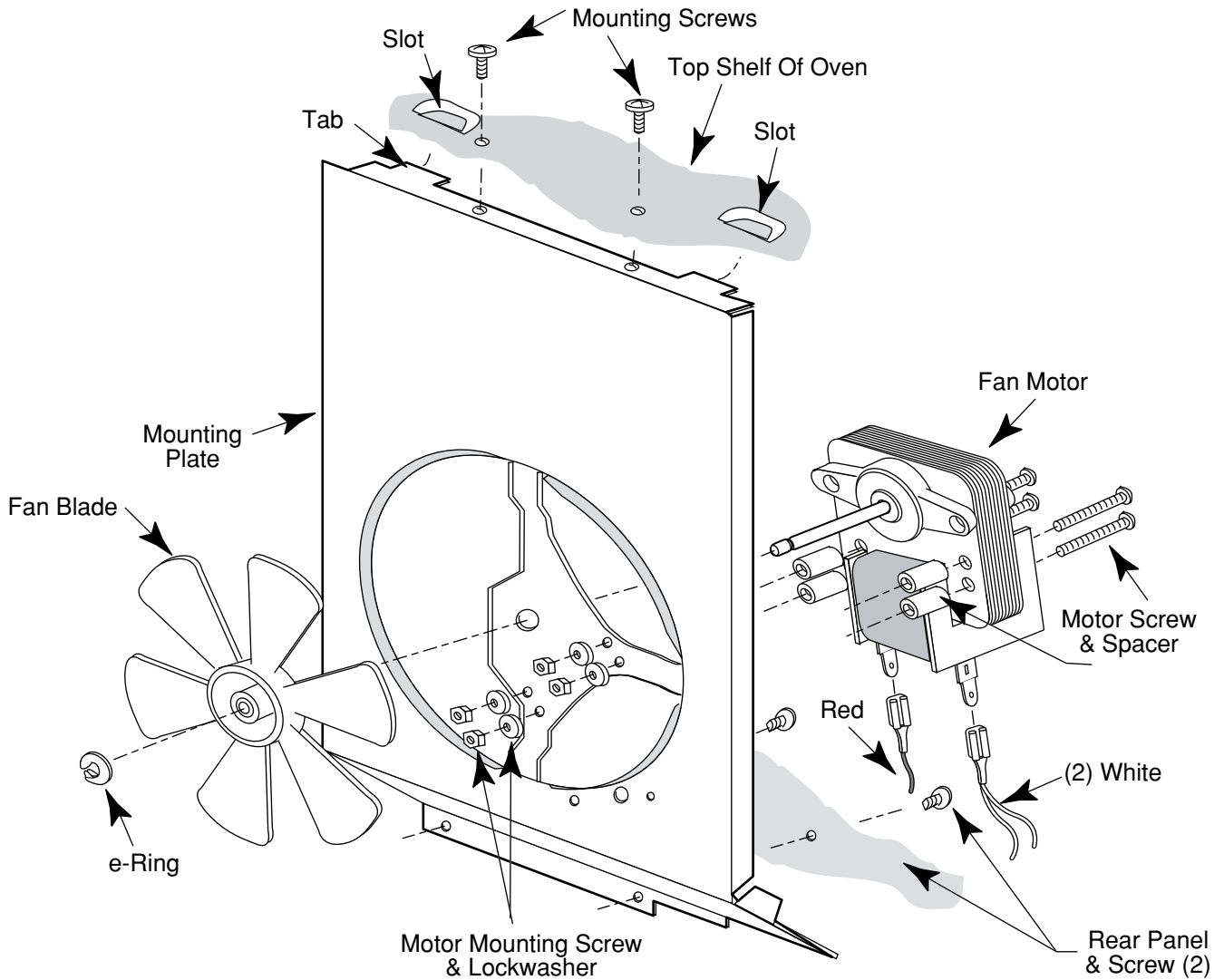

TESTING THE FAN MOTOR

1. Set the ohmmeter to the R x 1 scale and measure across the fan motor terminals. The meter should indicate 35 to 45 Ω .

REMOVING THE TURNTABLE MOTOR

1. Unplug the oven.
2. From the bottom of the oven, remove the turntable motor cover.
3. Remove the wires from the turntable motor terminals.
4. Remove the two mounting screws from the motor.

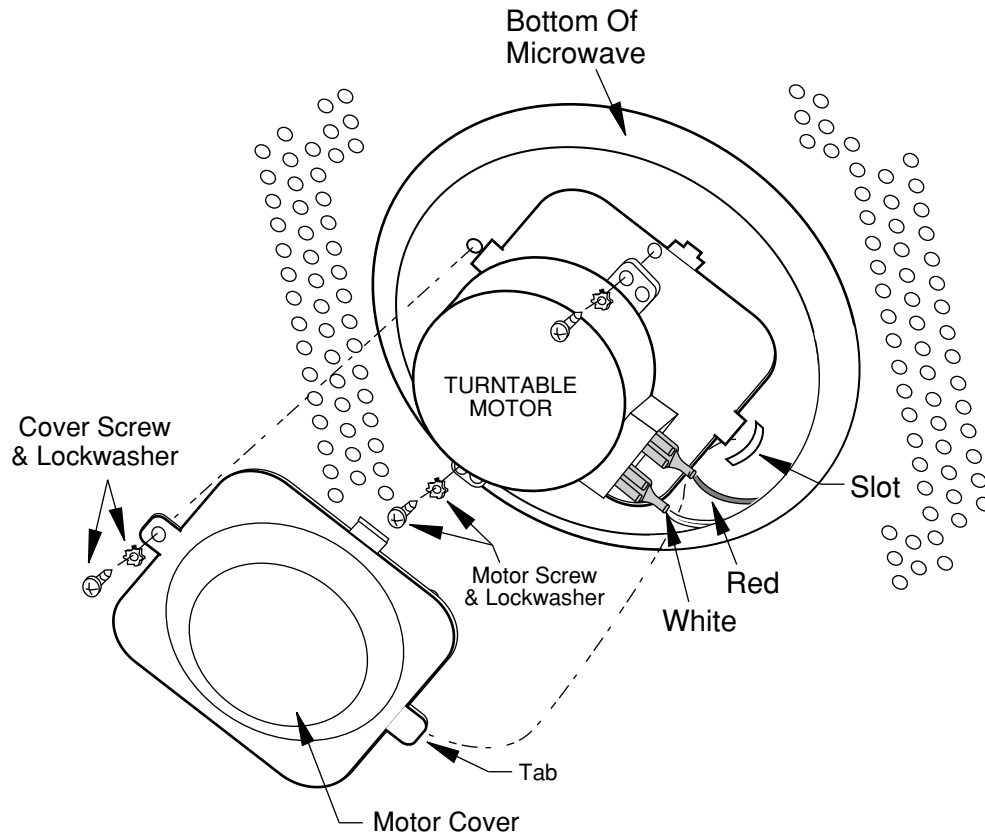

TESTING THE TURNTABLE MOTOR

1. Set the ohmmeter to the R x 1000 scale.
2. Measure the resistance across the motor terminals. The meter should indicate 1500 Ω .

REMOVING THE OVEN DOOR

1. Unplug the oven.
2. Remove the cabinet.
3. Discharge the high voltage capacitor using a 20,000 Ω , 2-Watt resistor.
4. Remove the mounting screws from the lower oven door mounting bracket and slide the door off the top bracket.

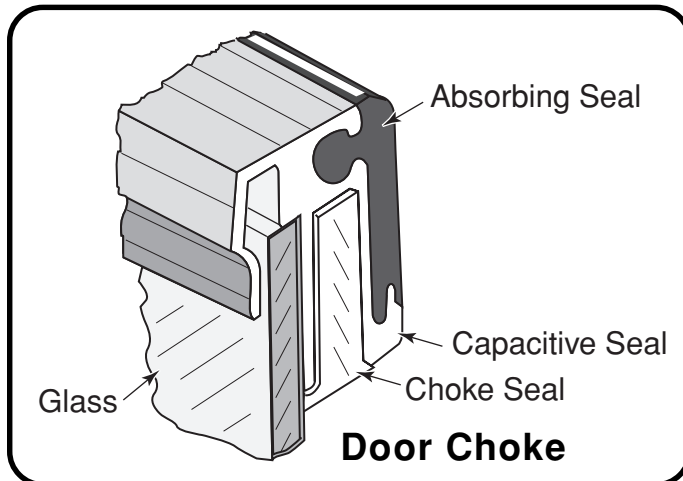

IMPORTANT: TOP HINGE IS PART OF DOOR AND IS NOT REMOVABLE

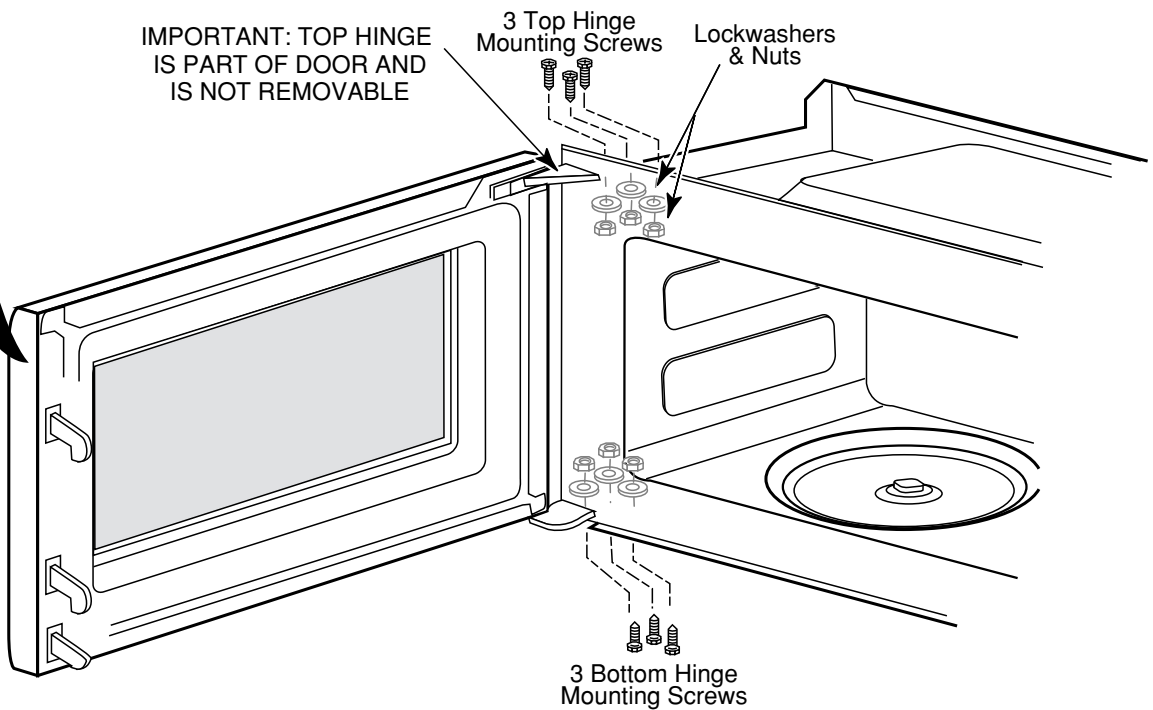

Performance Check

1. Remove and test the line and thermal fuses.
2. Remove and test the oven door switches.
3. Remove and test the fan motor.
4. Remove and test the turntable motor.

THE HIGH VOLTAGE SYSTEM

The High Voltage System includes the creation and transmission of microwave energy into the oven cavity. The system consists of:

- The High Voltage Power Transformer
- The High Voltage Capacitor & Rectifier (Diode)
- The Magnetron

REMOVING THE HIGH VOLTAGE POWER TRANSFORMER

1. Unplug the oven.
2. Remove the cabinet.
3. Discharge the high voltage capacitor using a 20,000 Ω , 2-Watt resistor.
4. Remove the wires from the high voltage power transformer terminals.
5. From under the cabinet, remove the two screws from the transformer mounting plate and slide the plate out of the mounting slots.

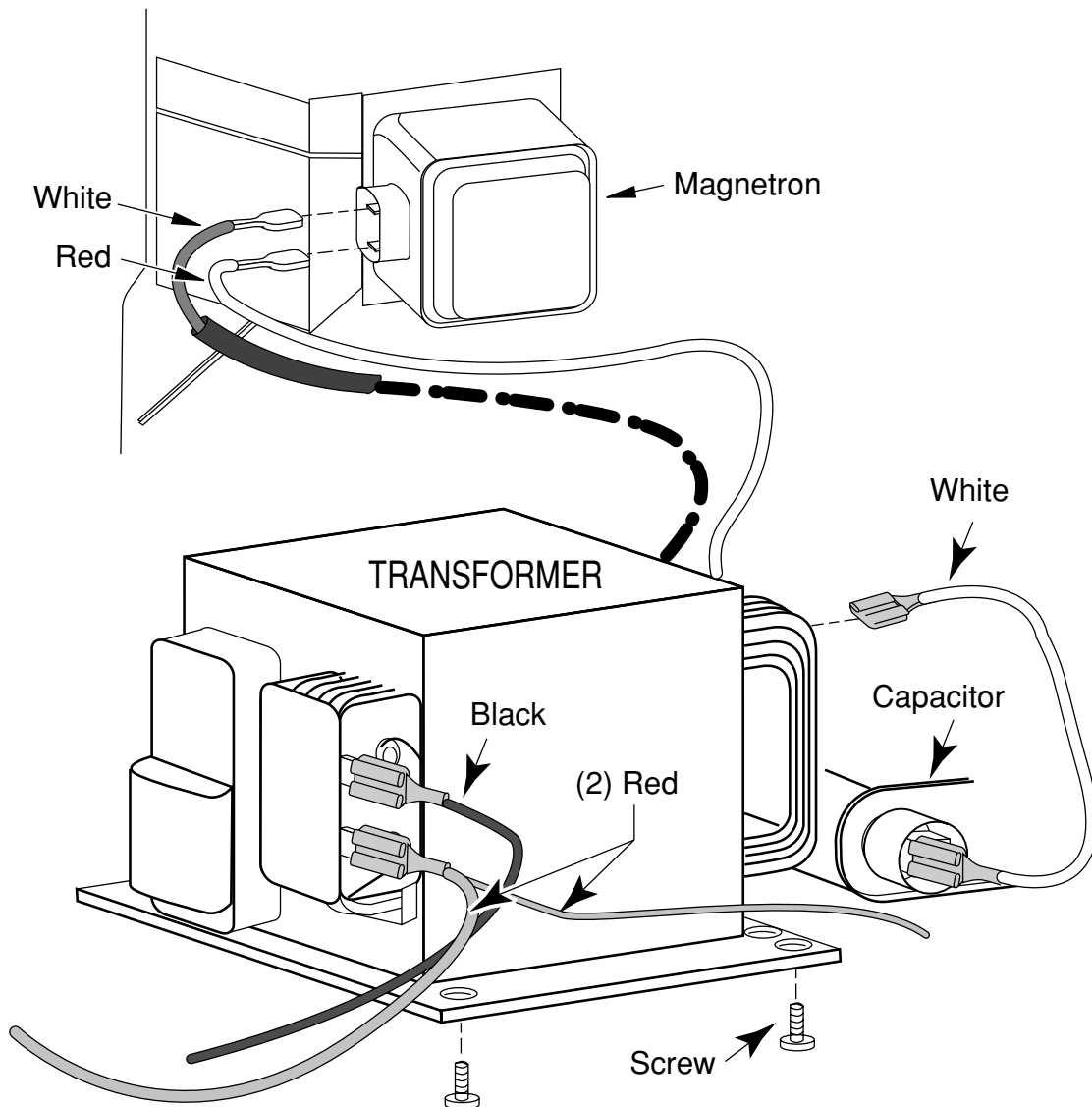

TESTING THE HIGH VOLTAGE POWER TRANSFORMER

1. Set the ohmmeter to the R x 1 scale. You should obtain the following readings:
 - Primary Winding = Less than 1 Ω .
 - Secondary Winding = 100 Ω .
 - Filament Winding = Less than 1 Ω .

REMOVING THE HIGH VOLTAGE CAPACITOR & RECTIFIER (DIODE)

1. Unplug the oven.
2. Remove the cabinet.
3. Discharge the high voltage capacitor using a 20,000 Ω , 2-Watt resistor.
4. Remove the wires from the high voltage capacitor terminals.
5. Remove the rectifier mounting screw, lockwasher, and nut.
6. Remove the capacitor mounting bracket screw.

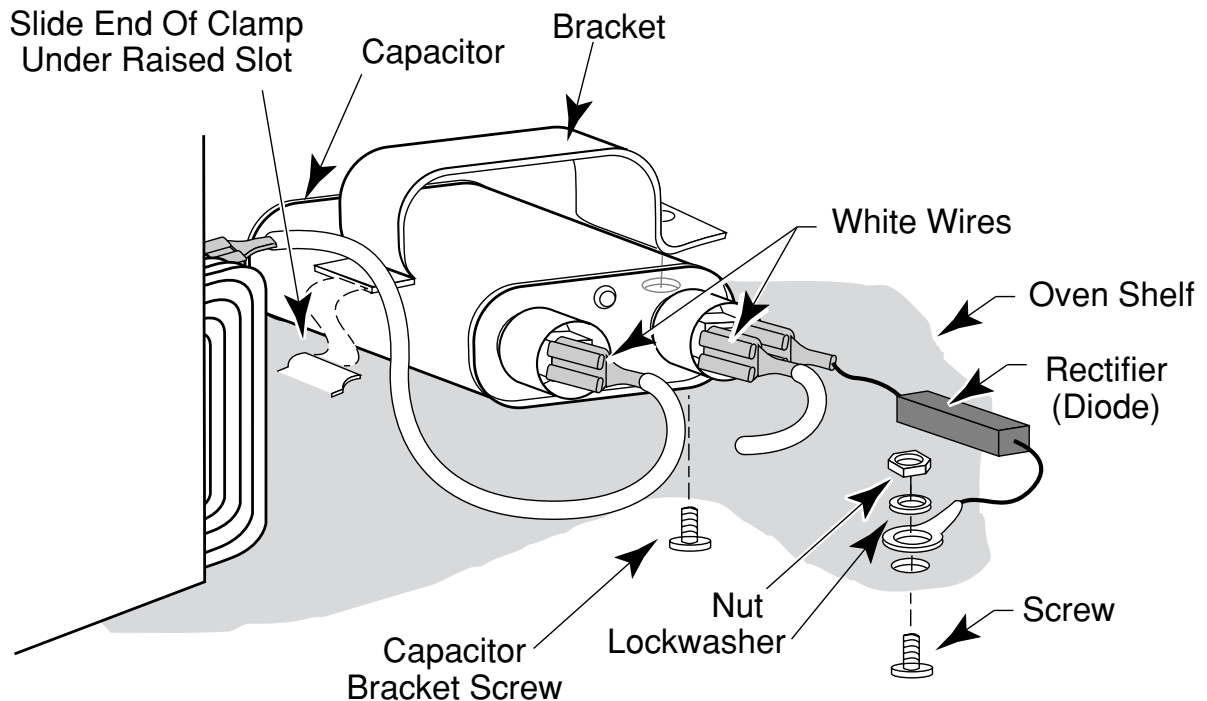

TESTING THE HIGH VOLTAGE CAPACITOR & RECTIFIER (DIODE)

1. **To measure the capacitor**, set the ohmmeter to the R x 1000 scale. From terminal-to-terminal, the meter should momentarily indicate several thousand ohms, and then gradually return to infinity.
2. **To measure the rectifier (diode)**, set the ohmmeter to the R x 10K scale, and touch the meter leads to the rectifier leads. In one direction, the meter should indicate infinity, and the other direction, it should indicate continuity.

REMOVING THE MAGNETRON

1. Unplug the oven.
2. Remove the cabinet.
3. Discharge the high voltage capacitor using a 20,000 Ω , 2-Watt resistor.
4. Remove the wires from the magnetron terminals.
5. Remove the four mounting screws, lockwashers, and nuts.

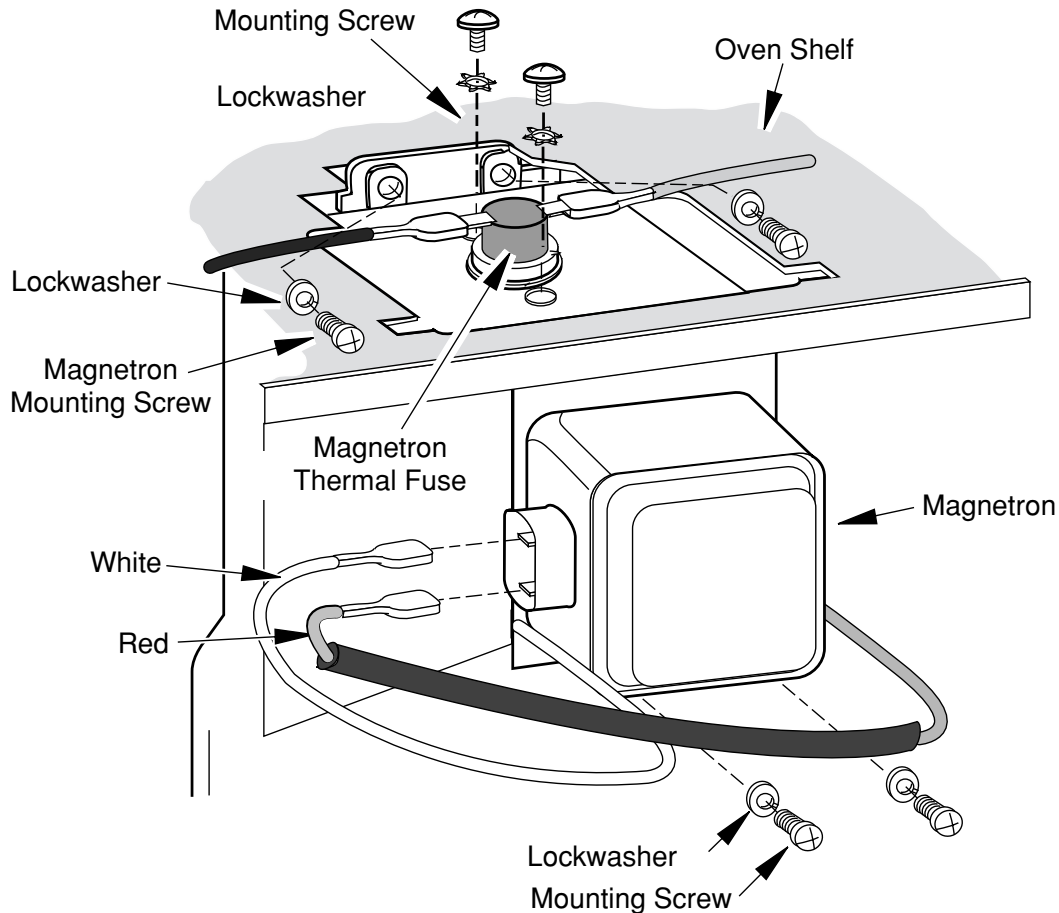

TESTING THE MAGNETRON

1. Set the ohmmeter to the R x 1 scale.
2. Measure the resistance across the terminals. The meter should indicate less than 1 Ω .
3. Set the ohmmeter to the R x 1000 scale.
4. Measure the resistance between the terminals and the chassis. The meter should indicate infinite resistance.

Performance Check

1. Remove and test the high voltage power transformer.
2. Remove and test the high voltage capacitor and rectifier (diode).
3. Remove and test the magnetron.

– Section 4 –

THEORY OF OPERATION

THE HIGH-VOLTAGE SYSTEM

THE POWER SUPPLY

The microwave oven power supply consists of a:

- **Power Transformer** that provides low AC voltage for the filament of the magnetron and high AC voltage for the cathode.
- **Capacitor** that stores both the negative and positive charges of the high voltage.
- **Rectifier** (diode) that controls the direction of current flow in the high voltage circuit.
- **Magnetron** that produces microwave energy.
- **Waveguide** that provides a path for microwave distribution.

The Power Transformer

The Power Transformer required to produce high energy microwaves must provide both low AC voltage and high DC voltage to the magnetron.

3.8 volts AC is produced by a secondary winding in the power transformer, and supplies the filament, or cathode, of the magnetron. The heat generated by this voltage “excites” the negatively-charged electrons on the cathode, where they move freely within the magnetron’s vacuum.

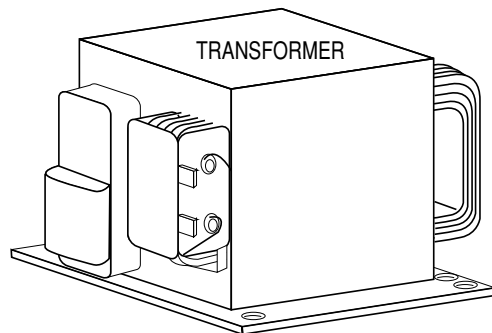

At this point, if no further energy is applied to the cathode, the freed electrons will not move, since the filament switches between the positive and negative charges of the AC current.

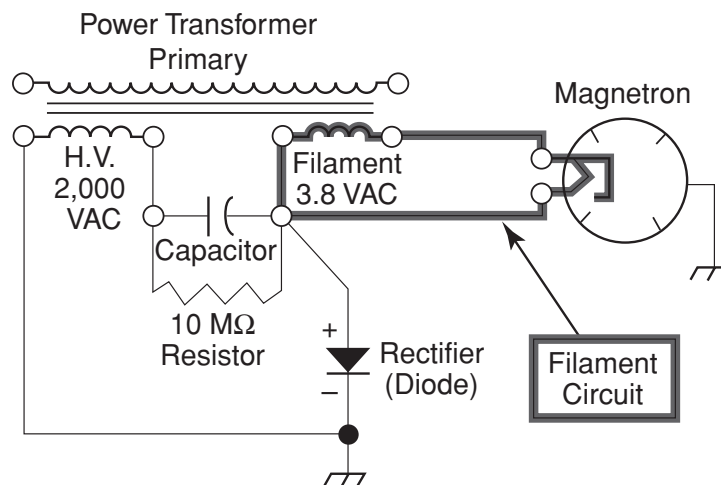

A voltage doubling circuit, which consists of the capacitor and rectifier, is used to create enough energy to overcome the natural resistance within the magnetron, and force the freed electrons to be used for conduction.

Approximately 2,000 volts AC is produced in a second winding on the secondary side of the power transformer. In the positive (+) half of the AC power cycle, the electrons will flow through a high voltage rectifier, or diode, to the capacitor.

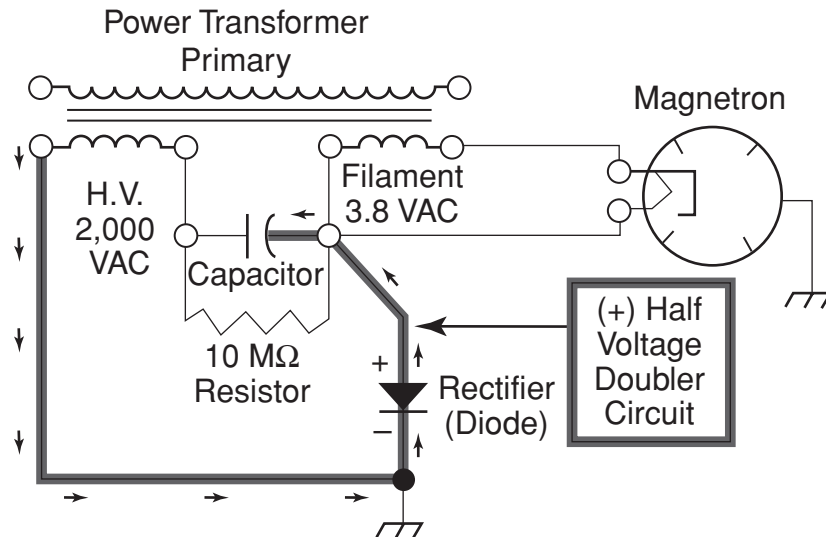

During the negative (-) half of the AC power cycle, the electrons will flow directly into the capacitor.

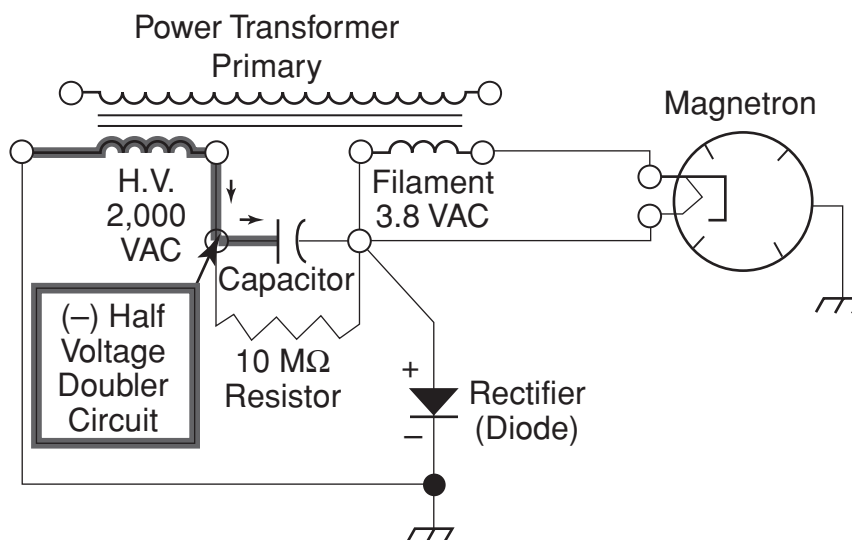

The Capacitor

A Capacitor is an electronic device that stores an electrical charge. A capacitor will hold this charge for a very long time unless it is provided with a path through which it can discharge the stored energy.

When the first 2,000 volts are charged on the capacitor from the positive half of the AC power cycle, there is no path for it to discharge the energy, since the resistance from the magnetron is high, and the diode will not allow electrons to flow backward through it.

When an additional 2,000 volts are charged on the capacitor from the negative half of the AC power cycle, the capacitor stores that charge as well. The capacitor is now charged with approximately 4,000 volts, and the energy level is high enough to overcome the high resistance of the magnetron. The capacitor will then discharge nearly all of its stored energy into the circuit.

The discharged energy of approximately 3,500 volts is nearly double the original voltage provided by the high voltage winding of the power transformer. The 500 volt difference is due to line loss caused by resistance in the wires between the capacitor and the magnetron, and the residual energy remaining in the capacitor.

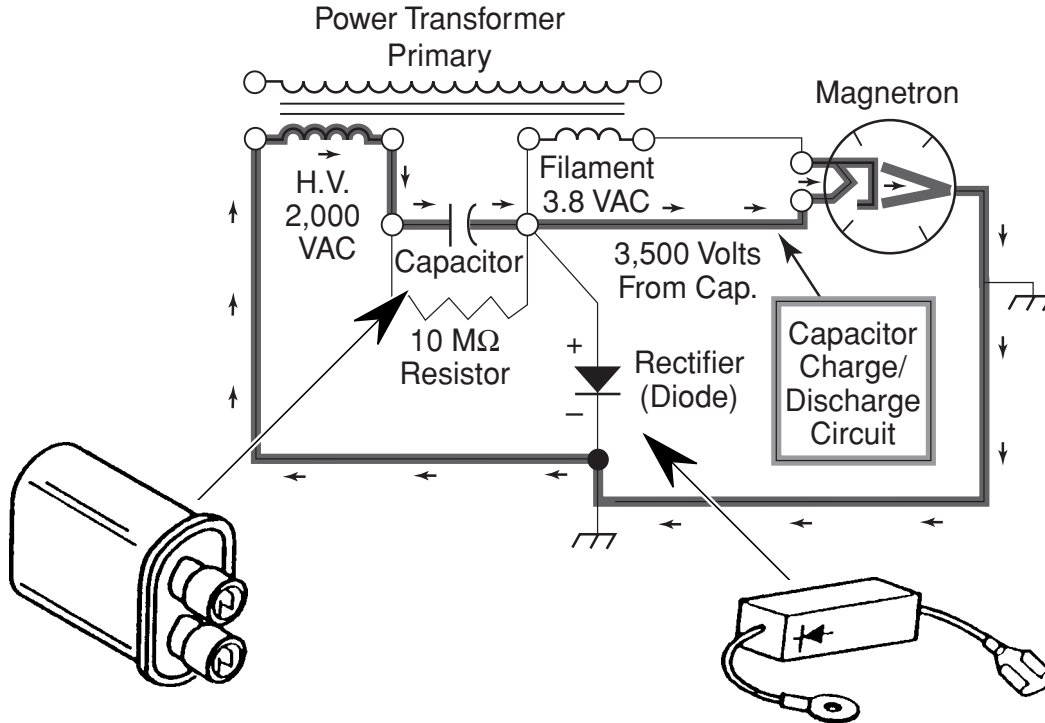

The Rectifier (Diode)

The Rectifier (Diode) is a solid state electronic device that allows current to flow in only one direction. The ability to restrict the flow of electrons makes it possible for the capacitor to hold its charge. If the diode could not stop the flow of electrons, the capacitor would discharge during the negative half of the AC power cycle, and would never be able to hold a full 4,000 volt charge to activate the magnetron.

The Magnetron

The Magnetron is a vacuum tube consisting of a cylindrical cathode at the center of a cylindrical anode. A permanent magnet provides a magnetic field to control the direction of the electrons. An antenna transmits the microwave energy away from the magnetron.

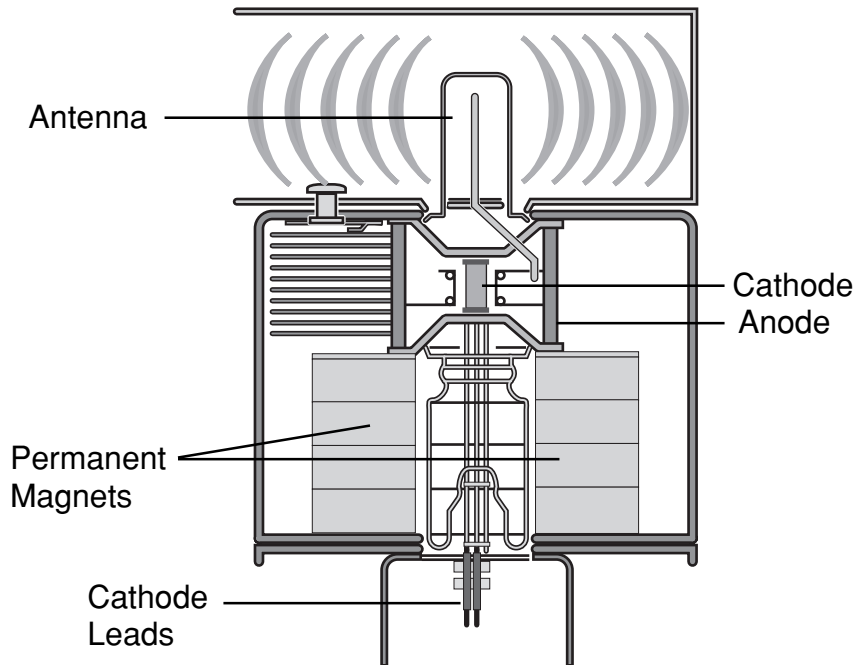

When a small amount of AC voltage is applied to the cathode, heat is generated. This heat excites the electrons on the cathode, where they begin to move freely from the outer surface in the vacuum space, between the cathode and the anode. However, there is not enough force or voltage to move the electrons directly toward the anode.

When the 3,500 volts discharged from the capacitor is applied to the cathode, enough force exists to cause the negatively charged electrons to rush toward the positively charged anode.

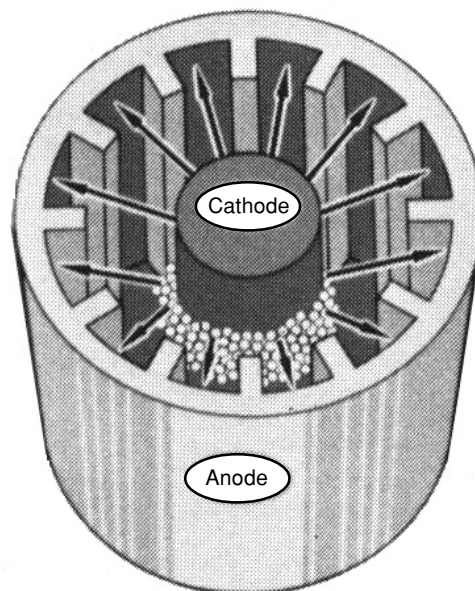

If nothing interferes with the electrons, they will naturally move in a straight line through the space between the cathode and anode. The magnetic field, created by the permanent magnet surrounding the anode, causes the electrons to group together, something like the spokes of a wheel, and rotate within the space. As this rotation occurs, the electrons collide with vanes that are attached to the inside surface of the anode.

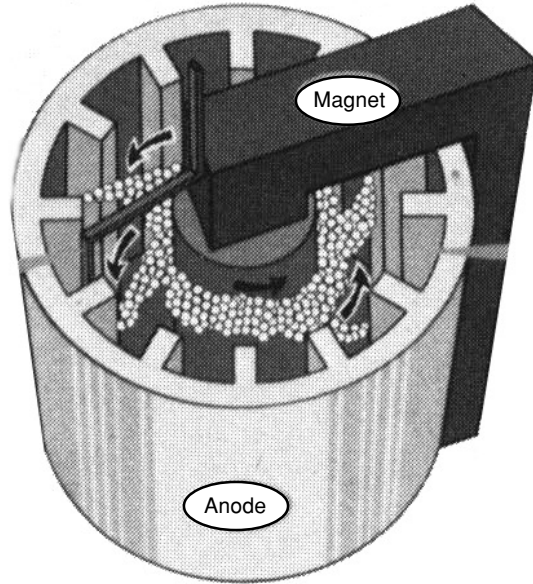

This collision, or interaction, between the electrons and the vanes of the anode, cause the anode to vibrate, or resonate, at a very high frequency. The diameter of the anode and the number of vanes determine the frequency of the vibrations. In the case of magnetrons designed for microwave cooking, the tuned resonance is 2,450 MHz.

A small antenna is located within one of the spaces between the vanes, which also vibrates at the resonant frequency, and transmits the microwave energy into the waveguide.

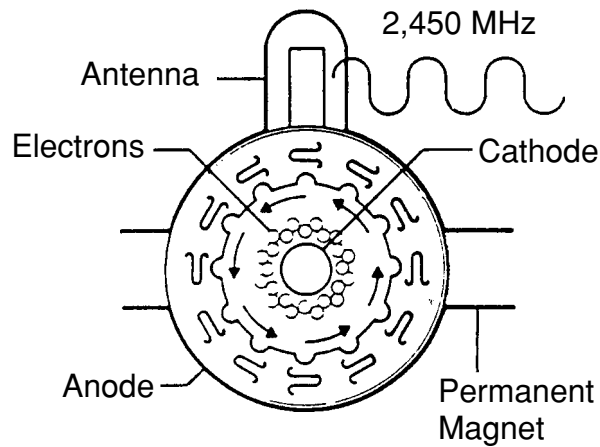

The Waveguide

The waveguide is made of reflective metal. It surrounds the magnetron's antenna at one end, and is open to the oven cavity at the other. Microwaves travel from the magnetron's antenna through the waveguide and into the oven from the top or side.

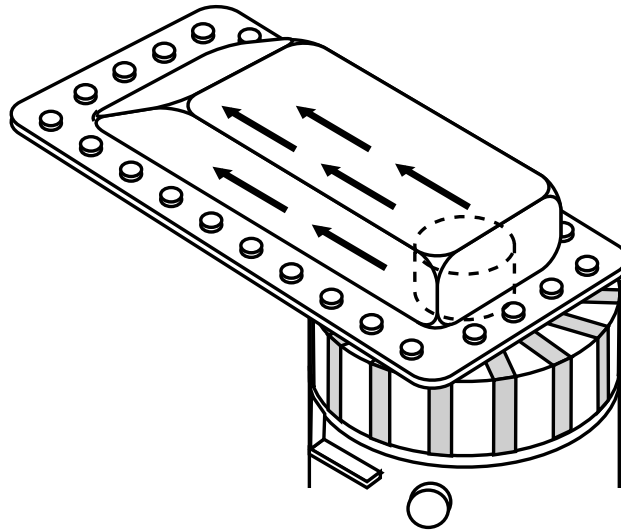

MICROWAVE DISTRIBUTION

Two systems are employed to distribute the energy waves within the oven cavity to assure even cooking. The first is a stirrer fan, located at the end of the wave guide, that spreads the microwaves around, allowing them to bounce off of the sides, top, and bottom of the oven so it will penetrate the food from all sides. The second system is a turntable which rotates the food to insure that the microwaves contact the food evenly. In addition, random bouncing of the waves in the oven increases full contact with the food.

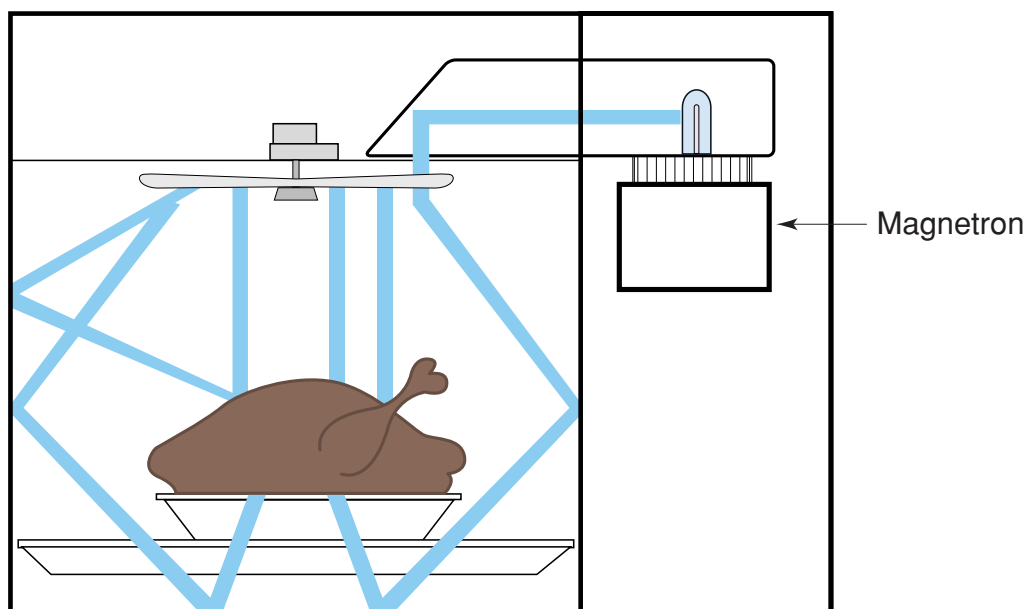

– Section 5 – DIAGNOSTICS

CAUTION

Before touching any oven component or wiring, always unplug the oven from its power source and discharge the capacitor by using a 20,000 ohm discharge resistor, or use an insulated plastic handle screwdriver to short across the capacitor terminals.

CAUTION

Check that the unit is grounded before troubleshooting. Be careful of the high voltage circuits. Discharge any static charge from your body by touching ground before handling any part of the circuitry on the control board. Electrostatic discharge may damage the control circuit.

It is extremely important for the technician to have a thorough understanding of the normal operation and function of the three major systems in a microwave oven in order to determine whether or not a malfunction exists, and how to properly diagnose it.

TOOLS & MEASURING INSTRUMENTS

Standard tools and test instruments are listed below.

- Wire cutters
- Long nose pliers
- Phillips screwdriver
- Adjustable wrench
- Two 1-liter beakers, or equivalent
- Volt-Ohmmeter (AC & DC)
- Electromagnetic radiation monitor
- 32 oz. glass beaker, or equivalent
- Glass thermometer (212°F or 100°C)

R.F. LEAKAGE TEST

From the customer's point of view, it is important to be able to provide them with assurance that their microwave oven is safe and operating within Federally established parameters for minimum microwave leakage.

Since such leakage is not readily apparent while the unit is operating, microwave leak tests should be performed both before and after any service is provided.

Microwave oven leakage tests require that the following items be used:

- An Electromagnetic Energy Leakage Monitor (NARDA 8100B, HOLADAY H1501)
- 8 oz. glass beaker for water

It may also be helpful to have a copy of the relevant Federal Regulations. These can be found in the Code of Federal Regulation, Health and Human Services, 21CFR1030, Performance Standards for Microwave Ovens.

LEAKAGE TEST PROCEDURES

Checks for microwave energy emissions must be made on every service call in. Leakage readings must be taken both before and after service has been performed and entered on the service record.

To test the microwave oven for R.F. leakage, perform the following steps.

1. Remove the cooking rack (if present) from the oven cavity.
2. Place a (8 oz.) glass of water at the center of the oven cavity.
3. Select "HIGH" cook power and turn the microwave oven on.
4. With an electromagnetic energy leakage monitor, test for R.F. leakage using the pattern shown below. Scan at a rate of one-inch-per-second, and measure at a distance of two inches from the surface at the following locations:
 - Check around the front of the CABINET.
 - Check around the DOOR.
 - Check around the CONSOLE PANEL.
 - Check horizontally across the DOOR.
 - Check vertically across the DOOR.
 - Check diagonally across the DOOR.
 - Check across the AIR VENTS on the bottom of the unit.
 - Check across the AIR VENT at the back of the unit.

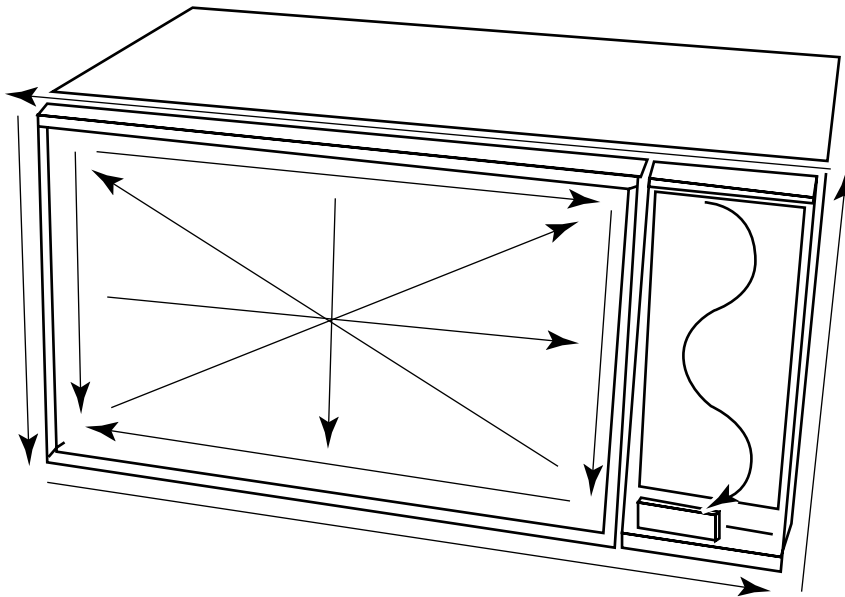

A properly operating door and seal assembly will normally register small emissions. These should not exceed the Federally established minimum standard of $4\text{mw}/\text{cm}^2$ R. F. emission at two inches distance with a maximum scan rate of one-inch-per-second.

All microwave ovens exceeding the emission level of $4\text{mw}/\text{cm}^2$ must be reported to the Service Department for microwave ovens immediately. The owner should be told NOT TO USE the microwave oven until it has been fully repaired.

COOKING CONDITIONS

CONDITION	POSSIBLE CAUSE	TEST PROCEDURE/ CORRECTION
1. Oven light does not turn on in cook cycle. Oven light turns on when door is opened.	1. Defective low voltage transformer of microcomputer board.	1. See strip circuits.
2. Oven light turns on but turntable motor does not operate.	2a. Defective wiring. 2b. Defective turntable motor. 2c. Open wiring of turntable motor.	2a. See strip circuits. 2b. Test turntable motor. 2c. Check connector & wiring.
3. Turntable drags or makes noise.	3. Excessive weight on tray or improperly balanced.	3. Distribute food evenly, cook smaller portions and/or use lighter weight cookware.
4. No input can be programmed. Some inputs cannot be programmed. Display shows a number of figures different from the one touched. Random programming when pressing other than touchpad. Display fixes some figures and can not accept any input.	4a. Defective membrane key of microcomputer board. 4b. Loose connection.	4a. Test membrane key of microcomputer board. 4b. Seat all connectors securely.
5. Setting time does not count down subsequent to touching START.	5a. Defective membrane key of microcomputer board. 5b. Loose connection.	5a. Test membrane key of microcomputer board. 5b. Seat all connectors securely.

MICROWAVE OPERATING CONDITIONS

CONDITION	POSSIBLE CAUSE	TEST PROCEDURE/ CORRECTION
1. Oven does not go into a cook cycle when START is touched.	1a. Primary and/or secondary interlock switches are defective or out of adjustment. 1b. Defective relay 1 of microcomputer board. 1c. Defective membrane key of microcomputer board.	1a. Test primary and secondary switches. 1b. Test relay 1 of microcomputer board. 1c. Test membrane key of microcomputer board.
2. Output power is too low.	2a. Defective fan motor. 2b. Low AC input power. 2c. Food temperature is too low. 2d. Defective relay 1 of microcomputer board.	2a. Test fan motor. 2b. Use at adequate line voltage. 2c. Cook for a longer time period. 2d. Test relay 1 of microcomputer board.
3. Output is too high when setting lower power levels.	3a. Defective relay 1 of microcomputer board. 3b. High AC input voltage.	3a. Test relay 1 of microcomputer board. 3b. Use at appropriate voltage.
4. Sparks occurring.	4a. Using metallic ware and allowing it to touch the oven wall. 4b. Ceramic ware trimmed in gold or silver powder is used.	4a. Do not use metallic ware for cooking, except where noted in the cookbook. 4b. Do not use any type of cookware with metallic trim.
5. Uneven cooking.	5a. Inconsistent intensity of microwave due to their characteristics. 5b. Food does not turn during cooking cycle. 5c. Turntable motor does not operate.	5a. Wrap the thinner food with aluminum foil. Use plastic wrap or a lid. Stir once or twice while cooking soup, cocoa or milk, etc. 5b. Food or cookware extending over edges of turntable preventing turning. Rearrange food. 5c. Test turntable motor.

Microwave Operating Conditions (Cont'd)

CONDITION	POSSIBLE CAUSE	TEST PROCEDURE/ CORRECTION
6. No microwave oscillation.	6a. Defective relay 1 on microcomputer board. 6b. Defective high-voltage transformer. 6c. Defective high voltage capacitor. 6d. Defective high voltage diode. 6e. Defective magnetron. 6f. Low AC voltage. 6g. Open or loose wiring to high voltage component or magnetron.	6a. Test relay 1 on microcomputer board. 6b. Test high voltage transformer. 6c. Test high voltage capacitor. 6d. Test diode. 6e. Test magnetron 6f. Use adequate line voltage. 6g. Check and repair wiring.
7. Oven operates properly in High Power but does not cook properly using another cooking power.	7a. Defective relay 1 of microcomputer board. 7b. Defective membrane key of microcomputer board.	7a. Test relay 1 of microcomputer board. 7b. Test membrane key of microcomputer board.

NOTES:

- A. Make sure that all wire leads are correctly positioned.
- B. When removing wire leads from component terminals, be sure to grasp the connector and not the wire.
- C. When replacing the magnetron, be sure to install the magnetron R.F. gasket in the correct position and then check to make sure that the gasket is in good condition.

Schematic

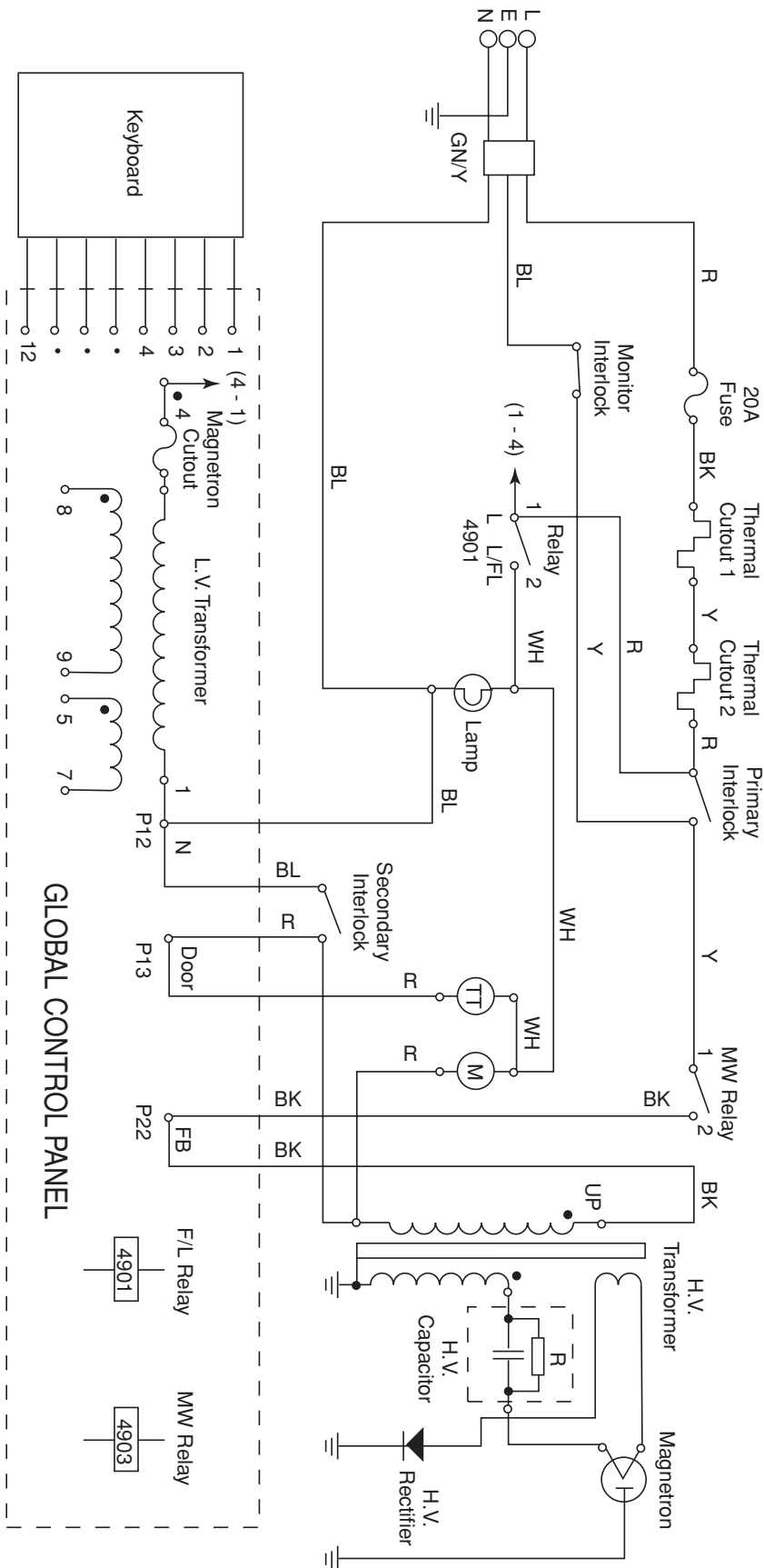

- CONDITIONS:**
1. Oven OFF.
 2. Oven Door Closed.
 3. Oven Light OFF.

Door Closed With Oven Operating

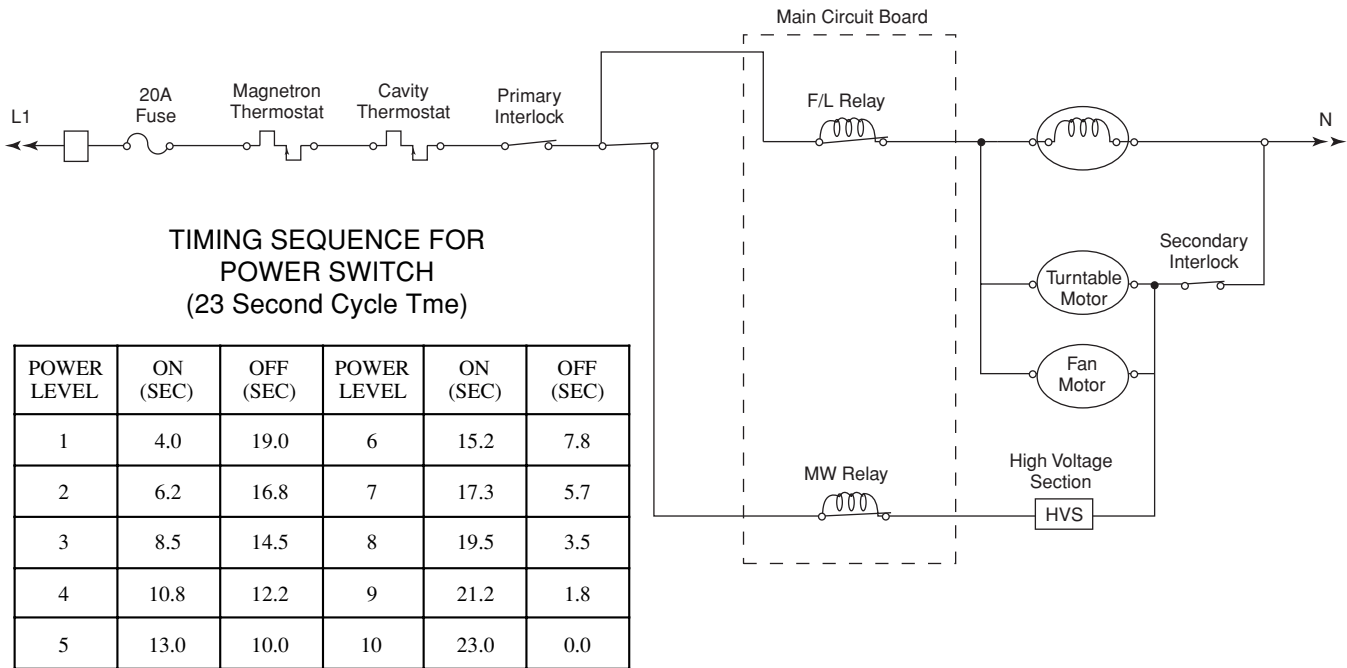

OVEN WILL NOT COOK

