

CONSUMER SERVICES TECHNICAL
EDUCATION GROUP PRESENTS

KM-24

OTR MICROWAVE/ CONVECTION OVEN

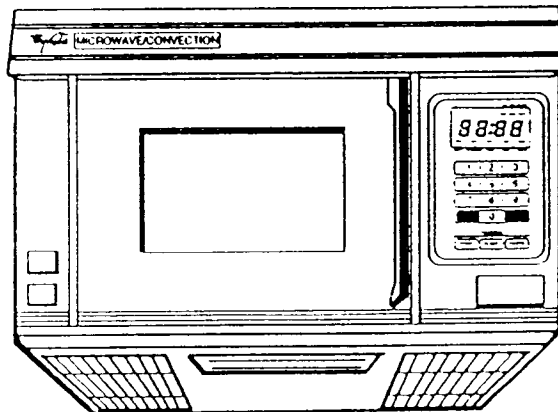

JOB AID
Part No. 4321693

ator-Freezers, Ice Makers, Dishwashers, Built-In Ovens and Surface Units, Ranges, Microwave Ovens, Trash Compactors, Room Air Conditioners, Dehumidifiers, Automatic Washers, Clot

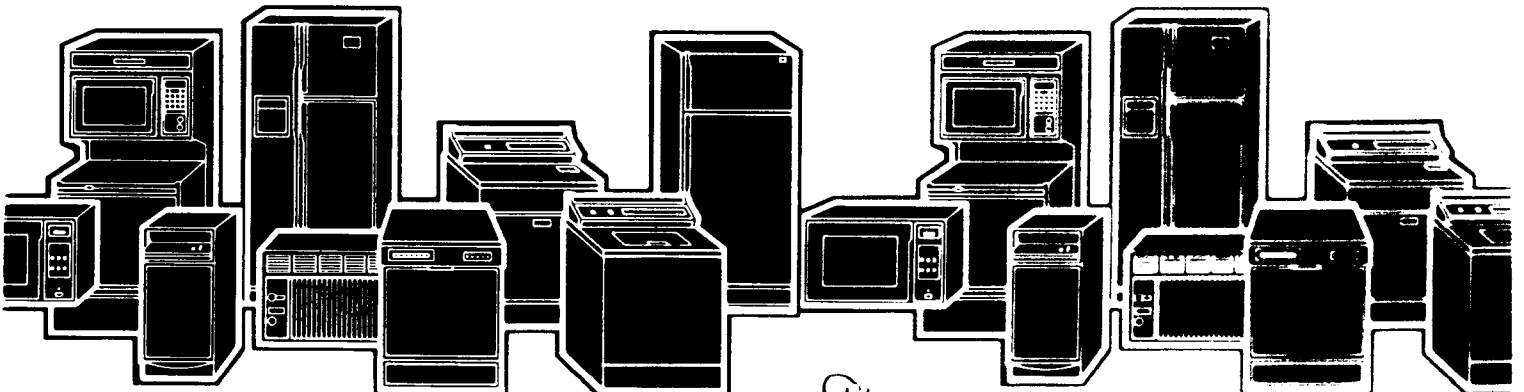

9/94

FORWARD

This Job Aid will introduce the technician to the Whirlpool OTR Convection/Microwave Oven. This Job Aid is a reference guide for the experienced technician. It is not designed as a replacement to basic training. This Job Aid does not replace the Service Manual or the Use and Care Guide. It is designed to be used in conjunction with these manuals.

OBJECTIVE

The objective of this Job Aid is to have the experienced appliance technician become familiar with the operation and service of the Whirlpool OTR Convection/Microwave Oven. It is designed as reference material and is not a replacement for basic training.

WHIRLPOOL CORPORATION assumes no responsibility for any repair made on our products by anyone other than Authorized Factory Service Technicians.

Copyright 1994 Whirlpool Corporation

Table of Contents

Important Safety Instructions	Page iv
Models Affected	Page 1
Mounting Bracket.....	Page 2
Blower Motor Mounting Positions	Page 3
The Gas Sensor.....	Page 4
The Convection Thermistor.....	Page 5
The Thermal Protectors.....	Page 6
The Blower Motor Capacitor	Page 8
The Convection Heating Element	Page 9
Motors	Page 10
Changing The Synchronous Motor	Page 11
Error Codes	Page 12
Hidden Features	Page 13
Things To Know	Page 16
Wiring Diagram	Page 17
Strip Circuits	Page 18
Skills Check.....	Page 22

IMPORTANT SAFETY INSTRUCTIONS

CAUTION

WARNING TO SERVICE TECHNICIANS

To avoid possible exposure to microwave radiation or energy, visually check the oven for damage to the door and door seal before operating any oven. Use a microwave survey meter to check the amount of leakage before servicing. In the event the R.F. leakage exceeds 4 mW/cm at 5 cm, appropriate repair must be made before continuing to service the unit. Check interlock function by operating the door latch. The oven cook cycle should cut off before the door can be opened.

The door and latching assembly contains the radio frequency energy within the oven. The door is protected by three safety interlock switches. Do not attempt to defeat them.

UNDER NO CIRCUMSTANCES SHOULD YOU TRY TO OPERATE THE OVEN WITH THE DOOR OPEN.

- Proper operation of microwave ovens requires that the magnetron be properly assembled to the waveguide and cavity. Never operate the magnetron unless it is properly installed.
- Be sure the "RF" seal is not damaged and is assembled around the magnetron dome properly when installing the magnetron.
- Routine service safety procedures should be exercised at all times.
- Untrained personnel should not attempt service without a thorough review of test procedures and safety information contained in this manual.

PRECAUTIONS TO BE OBSERVED BEFORE AND DURING SERVICING TO AVOID POSSIBLE EXPOSURE TO EXCESSIVE MICROWAVE ENERGY

- a. Do not operate or allow the oven to be operated with the door open.
- b. Make the following safety checks on all ovens to be serviced before activating the magnetron or other microwave source and make repairs as necessary.
 1. Interlock Operation
 2. Proper Door Closing
 3. Seal and Sealing Surfaces (Arcing, Wear and Other Damage)
 4. Damage to or Loosening of Hinges and Latches
 5. Evidence of Dropping or Abuse
- c. Before turning on the microwave power for any service test or inspection within the microwave generating components, check the magnetron, wave guide or transmission line and cavity for proper alignment.
- d. Any defective or misadjusted components in the interlock, monitor, door seal and microwave generation and transmission system shall be repaired or adjusted by procedures described in the Basic Service Manuals for the specific microwave oven being serviced before the oven is released to the owner.
- e. A microwave leakage check to verify compliance with Federal Performance Standards should be performed on each oven prior to release to the owner.
- f. Do not attempt to operate the oven if the door glass is broken.

Whirlpool microwave ovens have a monitoring system designed to assure proper operation of the safety interlock systems.

The interlock monitor switch will immediately cause the oven fuse to blow if the door is opened and the primary door interlock switch and/or the secondary interlock switch contacts fail in a closed position.

CAUTION: REPLACE BLOWN FUSE WITH 15 AMPERE CLASS H FUSE ONLY.

Test the upper and lower door interlock switches, cook relay and interlock monitor switch (middle switch) for proper operation as described in the component test procedures, before replacing the blown oven fuse.

DO NOT ATTEMPT TO REPAIR STICKING CONTACTS OF ANY INTERLOCK SWITCH, SAFETY SWITCH OR COOK (LATCH) RELAY. REPLACE THE SWITCHES AND RELAY.

Any indication of sticking contacts during component tests requires replacement of that component to assure reliability of the safety interlock system.

IF THE FUSE IS BLOWN, THE MONITOR, PRIMARY AND SECONDARY INTERLOCK SWITCHES MUST BE REPLACED. BE SURE THEY ARE PROPERLY CONNECTED.

Precautions to Avoid Possible Exposure to Excessive Microwave Energy

DO NOT attempt to operate the oven with the door open since open-door operation can result in harmful exposure to microwave energy. It is important not to defeat or tamper with the safety interlocks.

DO NOT place any object between the oven front face and the door or allow soil or cleaner residue to accumulate on sealing surfaces.

DO NOT operate the oven if it is damaged. It is particularly important that the oven door close properly and that there is no damage to the:

1. Door (bent).
2. Hinges and Latches (broken or loosened).
3. Door Seals and Sealing Surfaces.

DO NOT operate the microwave oven if the door window is broken.

The microwave oven should be checked for microwave leakage by qualified service personnel after a repair is made.

The oven should not be adjusted or repaired by anyone except properly qualified service personnel.

DO NOT operate the microwave oven with the outer cabinet removed.

CAUTION

- High voltages are present during the cook cycle. Extreme caution should be observed at all times.
- Abrasive cleansers, steel-wool pads, gritty wash cloths, etc. can damage the control panel and the interior and exterior oven surfaces. Use a sponge with mild detergent or paper towels with spray glass cleaner. Apply spray glass cleaner to paper towel. Do not spray directly on oven.
- Before touching any oven component or wiring, always unplug the oven from its power source and discharge the capacitor by using a 20,000 ohm discharge resistor or use an insulated plastic handle screwdriver to short across the capacitor terminals.
- Check that the unit is grounded before troubleshooting. Be careful of the high voltage circuits. Discharge any static charge from your body by touching ground before handling any part of the circuitry on the control board. Electrostatic discharge may damage the control circuit.
- Do not touch oven components or wiring during operation. Attach meter leads with alligator clips when making operational tests.
- For continued protection against radiation emission, replace only with these types of switches:
Primary (Interlock) Switch: SZM-V16-FA-63 or VP-533A-OF; Secondary (Interlock) Switch: SZM-V01-FA-32; Interlock (Monitor) Switch: SZM-V16-FA-62 or VP-532A-OF; Oven Lamp Switch: SZM-V6-FA-31 or VP-331A-OD.
- It is neither necessary nor advisable to attempt measurement of high voltage.
- Attaching the adaptor ground terminal to the wall receptacle cover screw does not ground the appliance unless the cover screw is metal and not insulated and the wall receptacle is grounded through the house wiring.

WARNING

- Disconnect the oven from electrical supply before servicing. Failure to do so could result in electrical shock or death.
- Improper use of the grounding plug can result in a risk of electrical shock. Do not, under any circumstance, cut or remove the third ground prong from the power cord plug.

Fire, Electrical Shock, Excessive Exposure to Microwave Energy, Personal Injury & Product Damage Hazard

- Do not block the rear air intake openings or exhaust vents. Allow a few inches of space at the back of the oven where intake openings and exhaust vents are located. Blocking the air intake openings and exhaust vents can cause damage to the oven and poor cooking results. Make sure the microwave oven legs are in place to ensure proper airflow.
- Do not install the oven next to or over a heat source (a cooktop or range).
- Do not install oven in any area where excessive heat and steam are generated. This could cause fire, electrical shock, excessive exposure to microwave energy, other personal injury or damage to the outside of the cabinet.

MODELS AFFECTED

(1994 & 1995 PRODUCTION)

Brand:	Whirlpool	Roper	KitchenAid	Estate
Features:				
Base Model	MH6110XBB/Q	MHE11RDB/Q		TMWH110DB/Q
Probe	MH7110XBB/Q			
Sensor	MH7115XBB/Q		KHMS105B (BL/WH/AL)	
Convection	MH9115XBB/Q		KHMC107B (BL/WH/AL)	

MOUNTING BRACKET

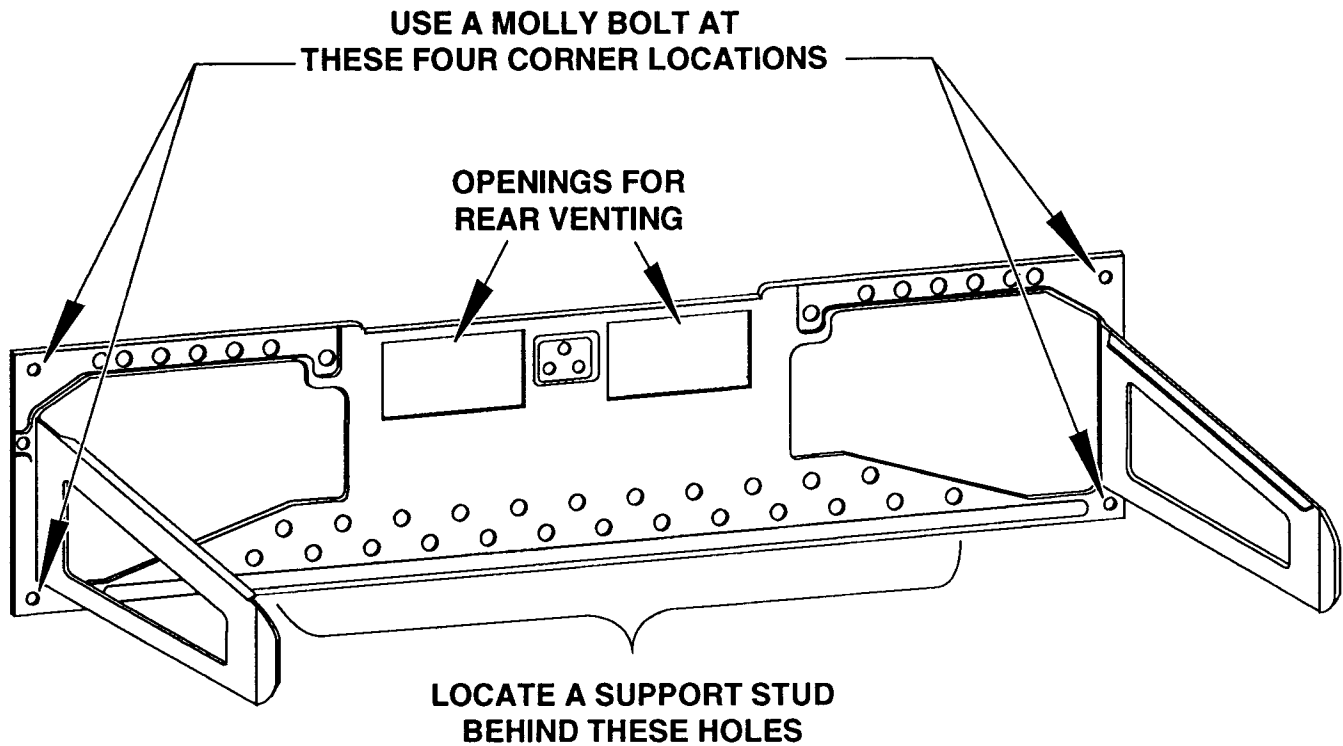

The mounting bracket for the OTR Microwave/Convection Oven should be installed as shown in the "Installation Instructions." These instructions include installing:

- Molly bolts in each of the four corners of the bracket.
- A 1-1/2" lag bolt in a wall stud using one of the holes along the top or bottom of the bracket.
- Spacers to mount on the back wall (as shown below).

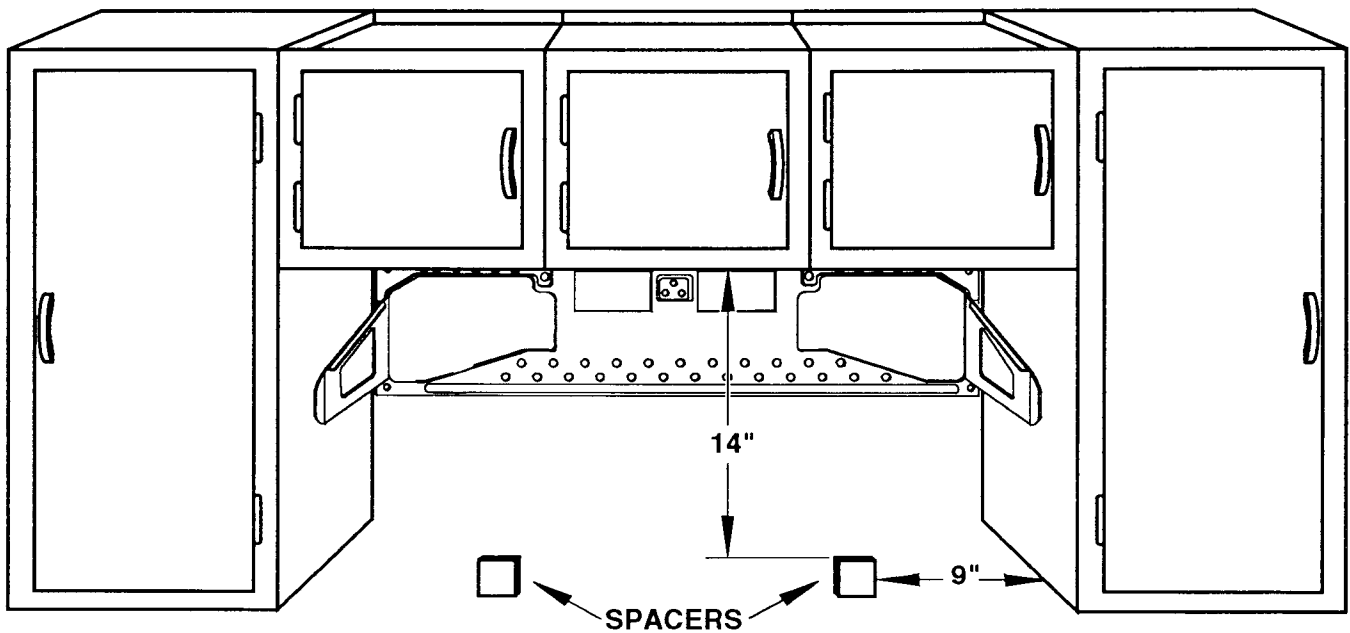

BLOWER MOTOR MOUNTING POSITIONS

Recirculating

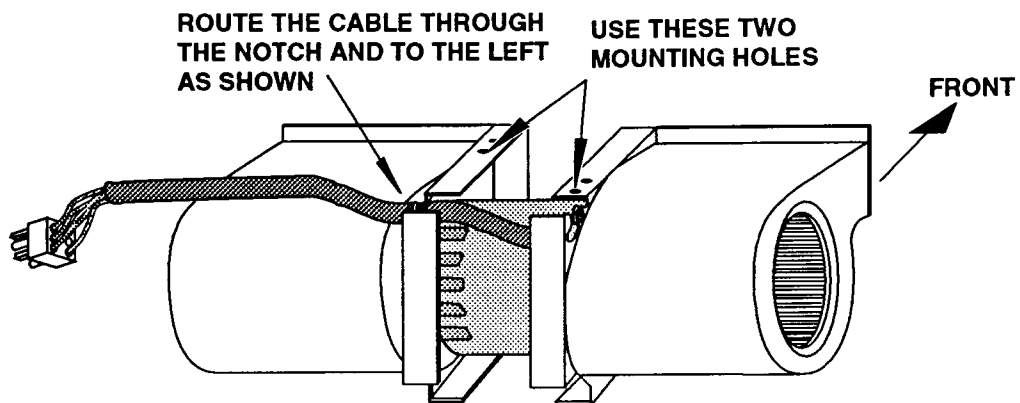

Rear Venting

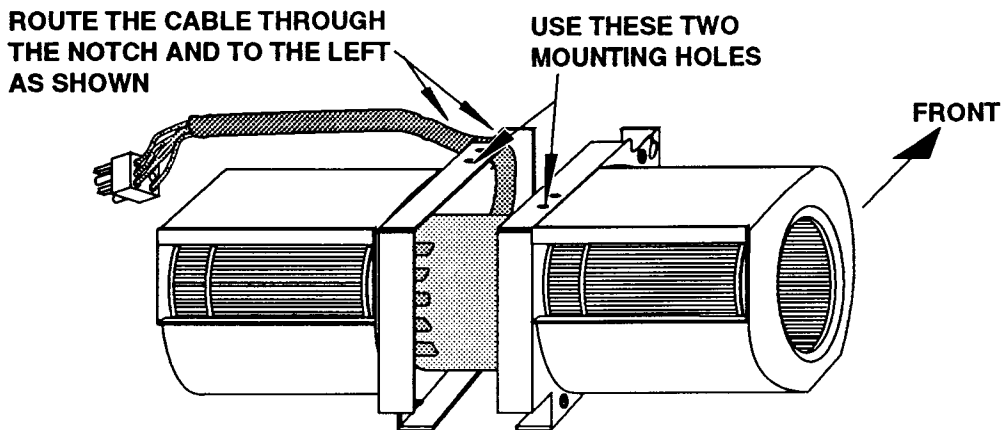

Top Venting

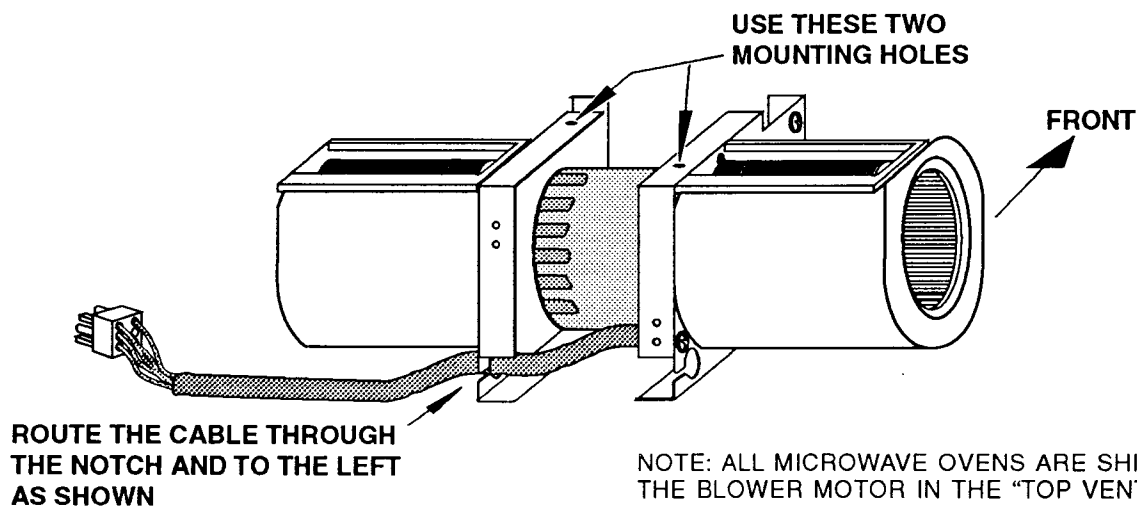

THE GAS SENSOR

The gas sensor is used during the "Sensor Cook" operation of the oven. It is located above the oven and is mounted on the left side of the sensor cover. The sensor consists of two circuits housed on a small microcomputer board that is supplied with a current to keep it heated. The sensor heat

conductivity will vary, depending upon the humidity of the oven. Changing humidity conditions, due to the cooking process within the oven cavity, causes a difference in potential between these two circuits. This difference is monitored by the microcomputer during cooking, allowing the microcomputer to determine the proper cook time.

NOTE: Always verify that the sensor cover is not obstructed (proper air flow is passing over the sensor), and that the fan motor is working properly, before replacing the gas sensor.

TESTING

1. Set the ohmmeter to the $R \times 1$ scale.
2. Remove the 3-pin connector from the control circuit board and measure the resistance between the:
 - a) Red & white wire terminals. You should measure 20Ω @ 68°F .
 - b) White & yellow wire terminals. You should measure infinity.

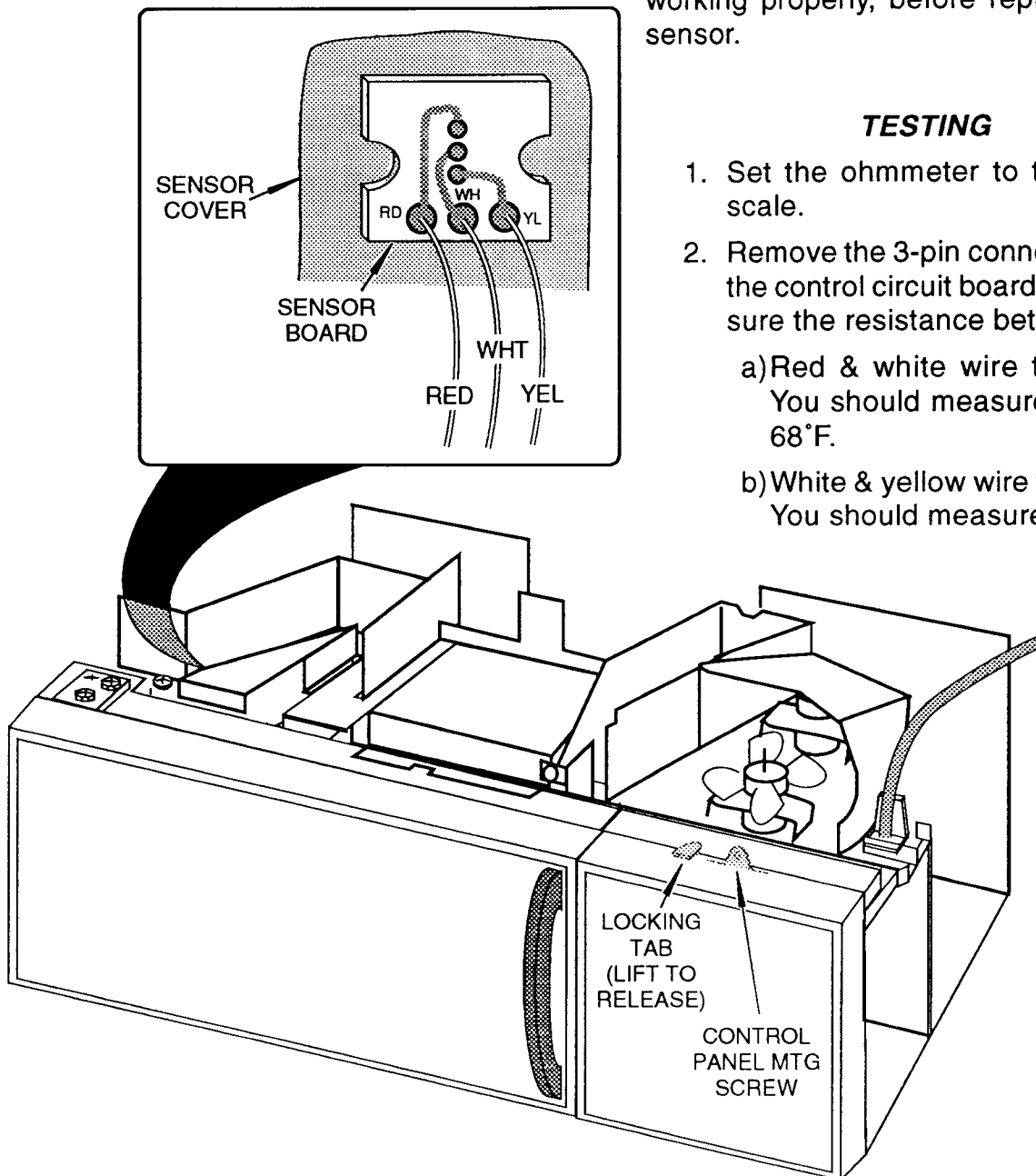

THE CONVECTION THERMISTOR

The convection thermistor is located under the circulation pulley cover and is used during the convection operation of the oven. When the temperature increases, the resistance of the thermistor decreases. The thermistor resistance is monitored by the microcomputer. As the oven temperature rises and

falls, the thermistor signal going back to the microcomputer causes the heater relay to open and close, and cycles the heating element on and off.

NOTE: Verify that the heating element is working correctly before replacing a thermistor.

TESTING

1. Set the ohmmeter to the $R \times 10K$ scale.
2. Remove the 6-pin connector from the control circuit board and measure across terminals 5 & 6.

You should measure $155 \text{ k}\Omega$ to $350 \text{ k}\Omega$ @ 68°F .

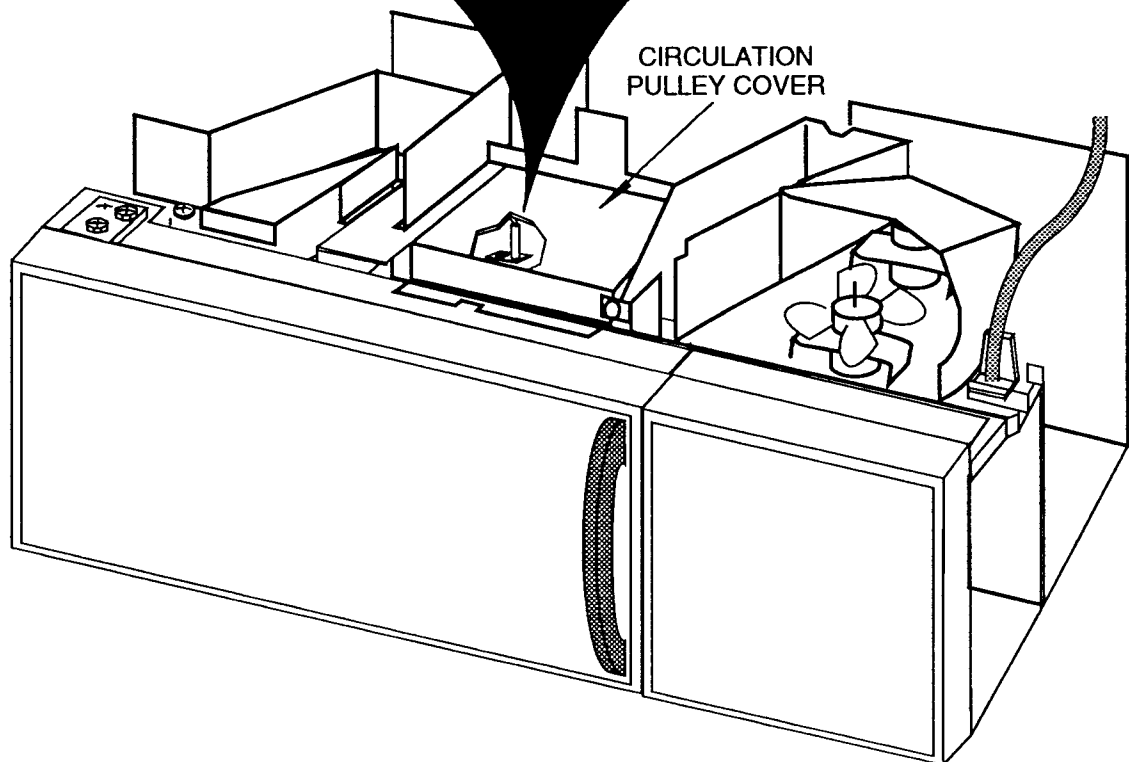
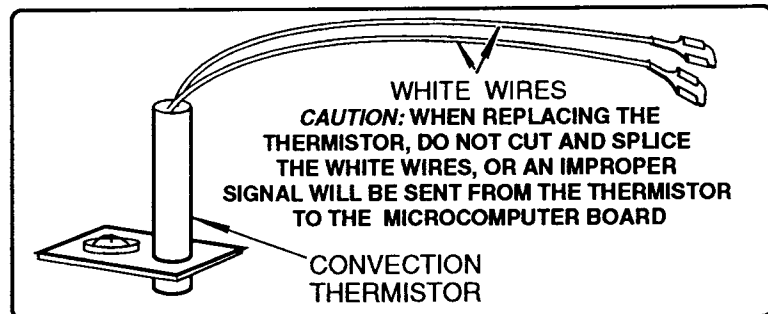

THE THERMAL PROTECTORS

There are three thermal protectors in the OTR Microwave/Convection Oven. They are: the magnetron thermal protector, the cavity thermal protector, and the base thermal protector. The magnetron and cavity thermal protectors are located inside the high-voltage section of the oven. These two thermal protectors are normally-closed, and will open at a set temperature to disable the oven. Both of these protectors are resettable.

The base thermal protector is located directly behind the control panel. It is a normally-open protector that, when closed, activates the blower motor at a low speed (see the wiring diagram on the next page).

POSSIBLE CUSTOMER COMPLAINT:

The unit turns on by itself.

Magnetron Thermal Protector	Opens @ 302°F/150°C	Resets @ 140°F/60°C
Cavity Thermal Protector	Opens @ 293°F/145°C	Resets @ 140°F/60°C
Base Thermal Protector	Closes @ 133°F/56°C	Resets @ 104°F/40°C

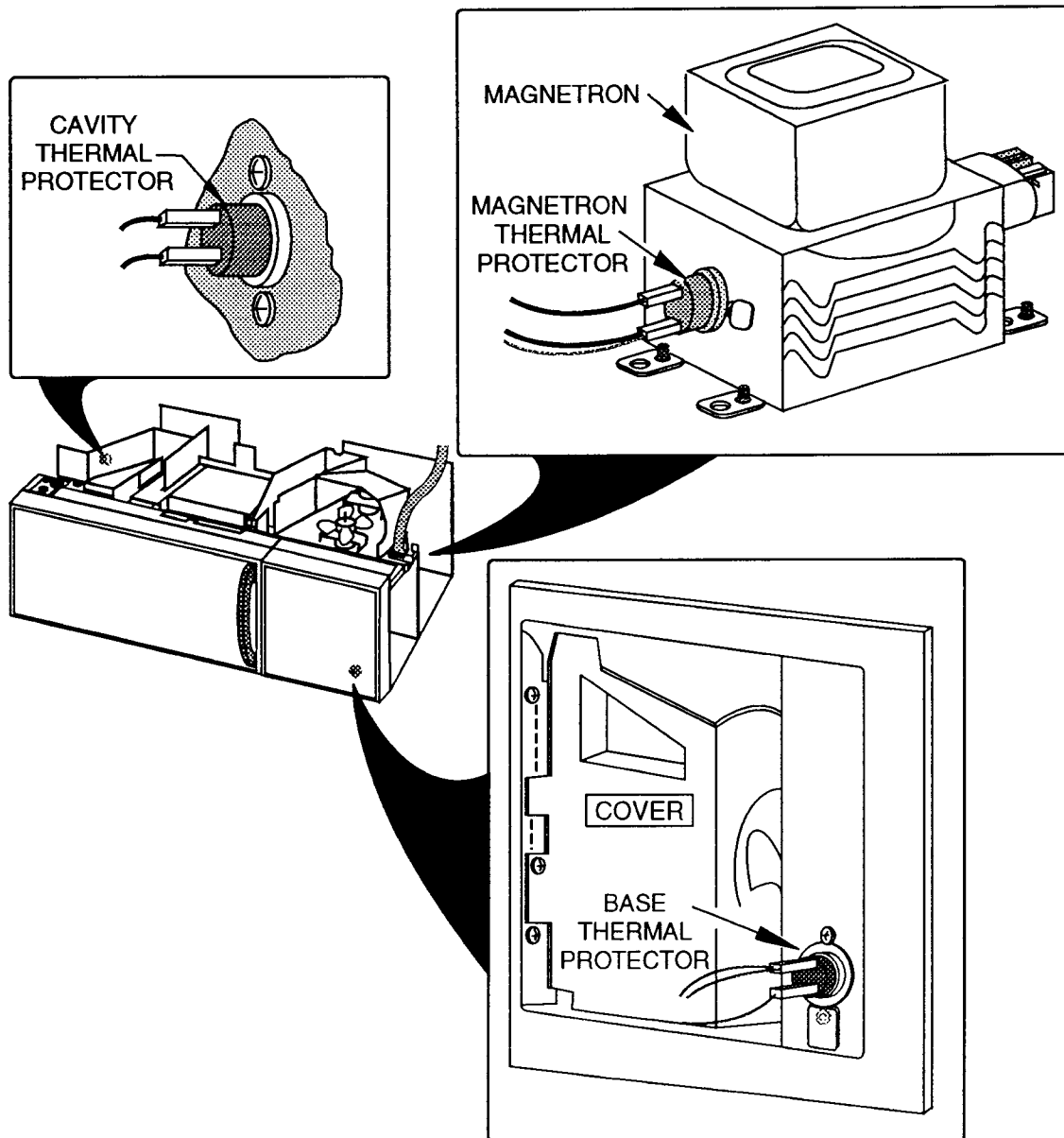

THE BLOWER MOTOR CAPACITOR

The blower motor capacitor is located directly behind the control panel*. It is in use any time the blower (vent) motor is operating. The

capacitor helps to maintain a constant voltage to the blower motor so that it runs more efficiently.

* Non-convection models may have this capacitor mounted in another location.

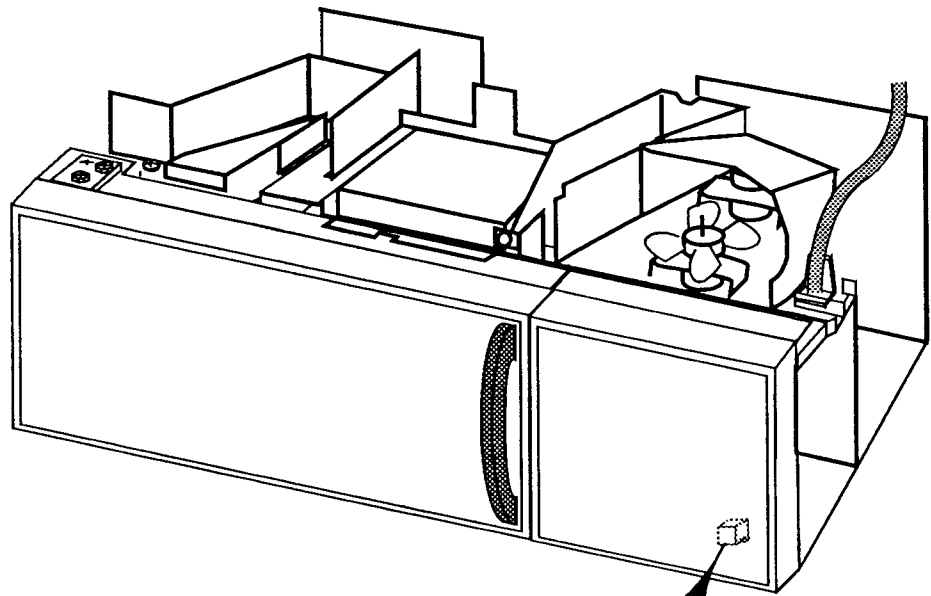

TESTING

1. Set the ohmmeter to the $R \times 10K$ scale.
2. Measure across the capacitor terminals.

The ohmmeter should indicate several ohms, then gradually return to infinity.

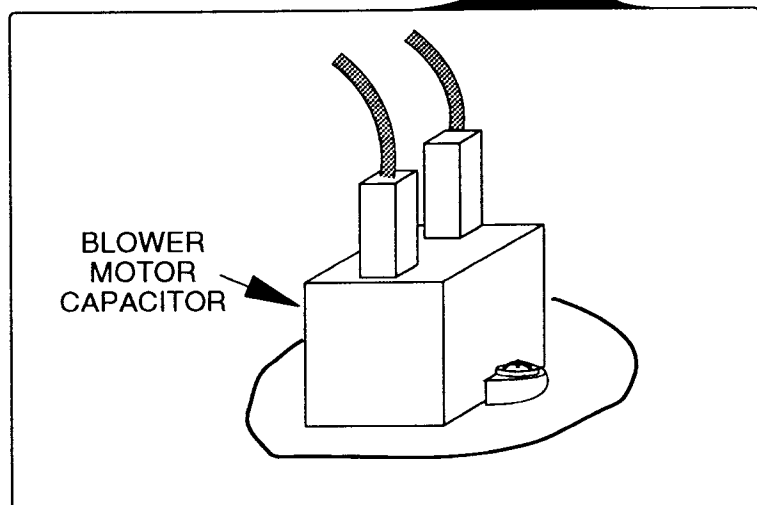

THE CONVECTION HEATING ELEMENT

The 1400-watt convection heating element is located under the circulation pulley cover and the top plate. The heating element heats the air that is distributed into the oven cavity by the convection fan. It operates on 120 VAC and is controlled by the convection ther-

mistor, and the heater relay on the micro-computer board. During a convection, or combination cooking cycle, the heater cycles on and off to maintain the programmed cavity temperature. The heating element surrounds the convection fan blade and is not visible through the oven cavity.

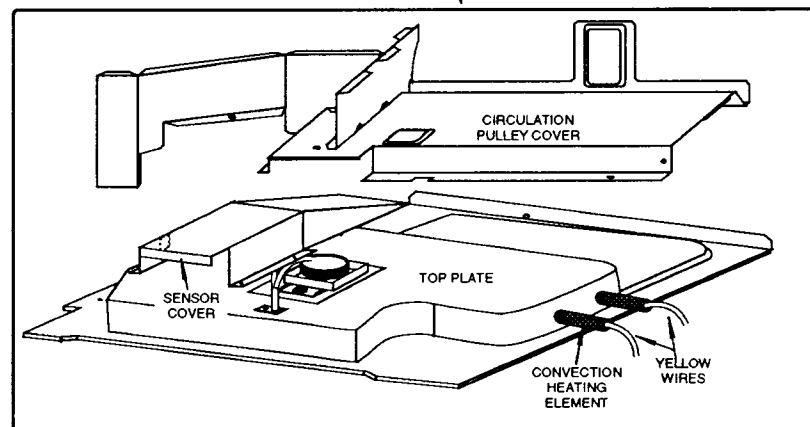
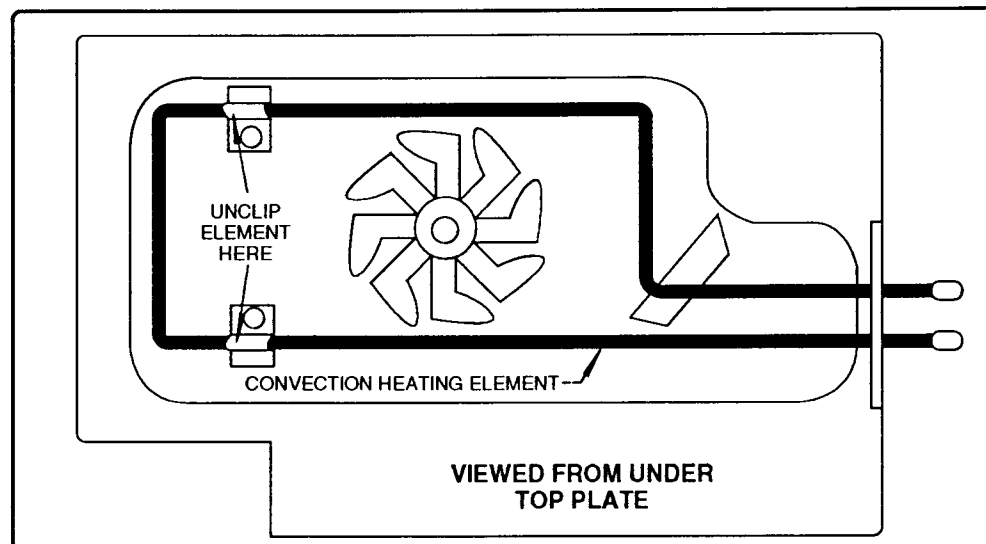

TESTING

1. Set the ohmmeter to the $R \times 1$ scale.
2. Measure across the heating element terminals.

You should measure between 40Ω and 90Ω @ 68°F .

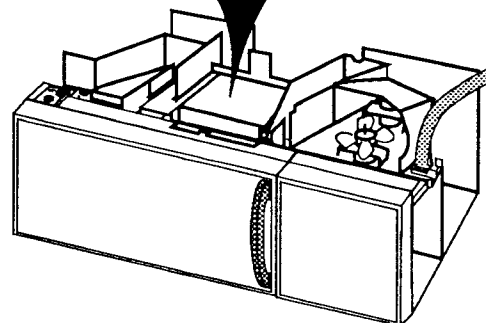

MOTORS

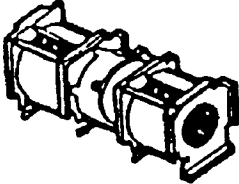
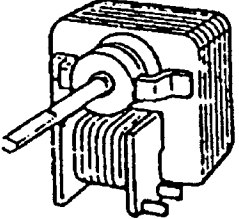
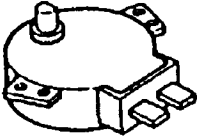
	<p>Blower Motor—Removes smoke and odors from the kitchen cooking area through outside venting or recirculation.</p>
	<p>Circulation Motor—Circulates heated air inside the oven during convection cooking.</p> <p>Tower Motor—Circulates air through the electrical section of the oven during microwave and convection cooking to cool it.</p> <p>Fan Motor—Cools the magnetron and circulates air through the oven during microwave cooking.</p>
	<p>Synchronous Motor—Distributes microwave energy into the oven during microwave cooking.</p>

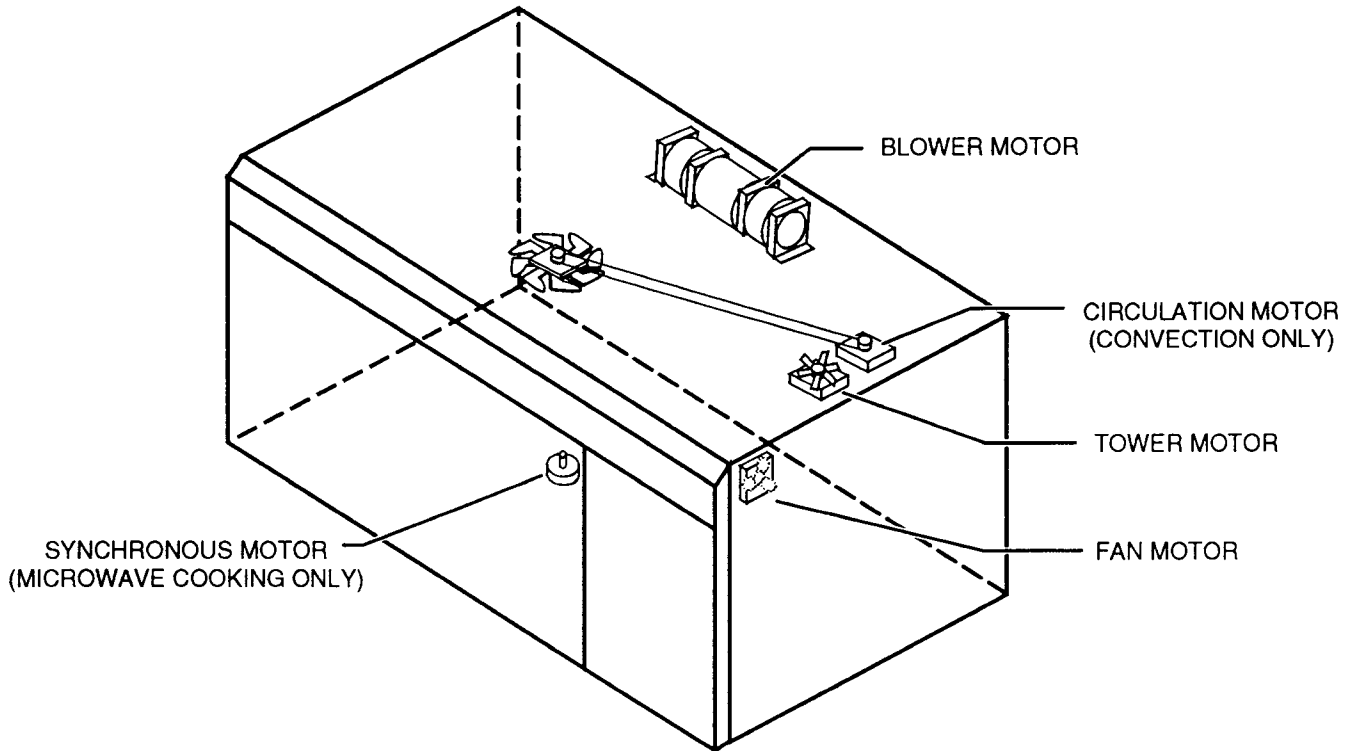

CHANGING THE SYNCHRONOUS MOTOR

To remove the synchronous motor:

1. Remove the baseplate from the oven.
2. Open the oven door and pry up the bottom panel of the oven cavity (inset #1).
3. Lift the distribution plate off the motor shaft.
4. Remove the synchronous motor from the bottom of the oven (inset #2).

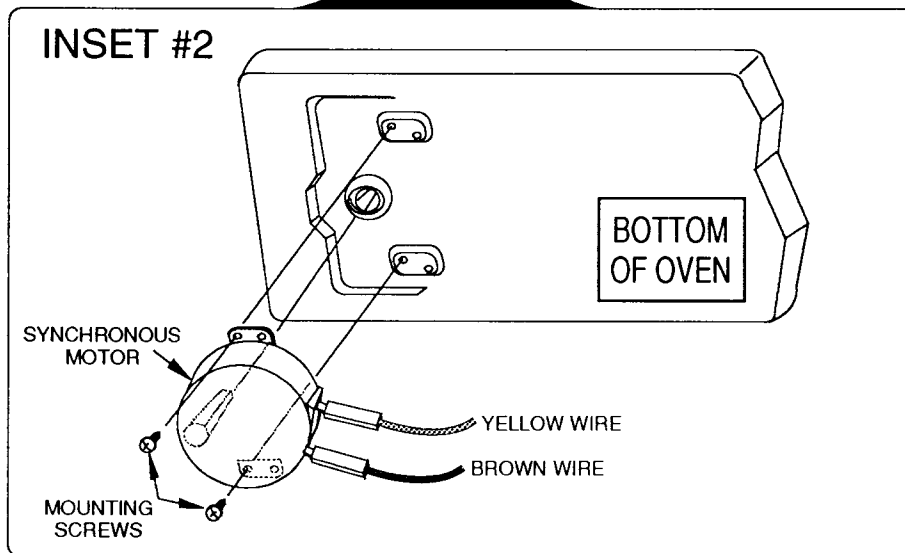
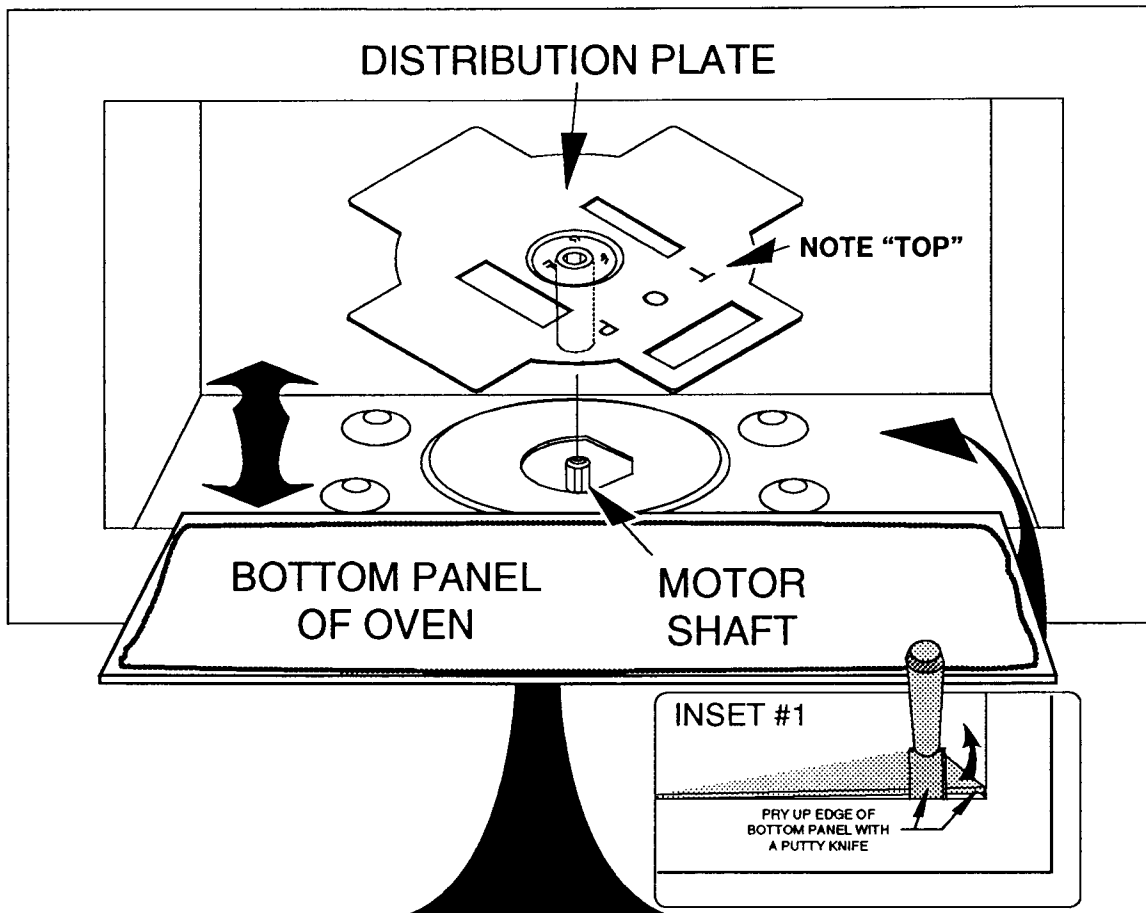

ERROR CODES

Missing Probe or Invalid Probe.



If the temperature probe is not plugged in for an operation that requires its use, or if it is plugged in and the selected operation does not allow its use, a “probe” error will be displayed when the **START/enter** keypad is pressed.

Heating Or Control System Component Failure.



Whenever any of the critical components in the heating or control system encounter a failure mode, the OTR Microwave/Convection Oven will shut down operation. All keypads, except **OFF/CANCEL**, will cause an invalid data entry signal if pressed before the problem is corrected or cleared. If a cooking operation is attempted before the problem is corrected, the failure code will be redisplayed and the operation will once more be shut down. **This implies, for example, that after a temperature probe failure occurs, and the error code is cleared, all other operations not utilizing the temperature probe, will still function.**

The “-F2-” & “-F4-” display code may be cleared so that the clock is visible and the minute timer may be used. Both of these operations will continue uninterrupted in the background, if a failure occurs while either is active. The failure code is cleared by pressing the **OFF/CANCEL** keypad.

The following error codes will be displayed when the associated failure mode has occurred:

- F1- *Gas Sensor* — Error will occur if no change in resistance is detected by the microcomputer board over time.
- F2- *Keyboard* — Error will occur if a keypad is pressed, or shorted for 15-seconds.
- F3- *Thermistor* — Error will occur if the oven cavity temperature fails to change.
- F4- *Temperature Probe* — Error will occur if the internal temperature of the food does not change.

888:88 Will be displayed after power has been interrupted.

An audible signal should sound when a failure code appears on the display. The error code will remain in the display until the **OFF/CANCEL** keypad is pressed.

HIDDEN FEATURES

DISABLING/ENABLING THE AUDIBLE SIGNALS

1. Touch and hold numeric keypad #1 for four seconds. When the time has elapsed, you will hear two beeps, which signals that the “programming tone,” and the “end-of-cycle reminder” signals are disabled.

OR

2. Touch and hold numeric keypad #2. When the time has elapsed, you will hear two beeps, which indicates that all of the signals, except the “end-of-timer,” are disabled.
3. To turn the audible signals back on, repeat the step that disabled it.

NOTE: Two tones will sound when the audible signals are turned on or off.

THE DEMONSTRATION FEATURE

NOTE: You can only use the demonstration feature after the OTR Microwave/Convection Oven is first plugged in. Once a command pad has been touched, the feature cannot be used, unless the unit is unplugged and plugged back in again.

To set the oven so that it will demonstrate its functions without turning the oven on:

1. Open the oven door.
2. Touch and hold the **AUTO START** keypad. You will hear three tones, followed a few moments later by two more tones.
3. Release the **AUTO START** keypad.
4. Close the oven door, and the demonstration feature will begin. To stop the demonstration feature, touch the **OFF/CANCEL** keypad, otherwise, it will continue to run.

THE SAFETY LOCK FEATURE

POSSIBLE CUSTOMER COMPLAINT:

The safety lock feature disables the front panel controls to prevent small children from using the microwave oven. However, the fan and the cooktop light will still be operational.

To deactivate the front panel controls:

1. Touch and hold numeric keypad #3. You will hear three tones, followed a few moments later by two more tones. You will then see a lock  on the display.
2. Release the keypad, and the front panel controls will be deactivated.

NOTE: The exhaust fan and night light functions will still operate.

To reactivate the front panel controls:

1. Touch and hold numeric keypad #3 until you hear two tones and see the lock on the display disappear.
2. Release the numeric keypad, and the front panel controls will be reactivated.

TIMED FAN

The “timed fan” feature provides a method for controlling the hood fan speed. It also allows the fan to be time-limited with the use of the **TIMER** keypad. To set the fan operating time, the fan must first be running. After pressing the **HIGH** or **LOW** keypad, press the **TIMER** keypad twice within 3-seconds.

The first press will light the *ENTER* and *TIMER* display, and *TIME* will be displayed.

The second press will cause *TIME* to be cleared from the display, and *FAN* to be displayed in its place. The display will remain the same.

Pressing the **TIMER SET** keypad will toggle between the *FAN* and *TIMER* displays.

When a numeric keypad is pressed, the display will be cleared, and the number entered will be shown in the display to the far right.

TIMED LIGHT

The “timed light” feature provides a method for controlling the vent hood light. It also allows the light to be time-limited with the use of the **TIMER** keypad. To set the light operating time, the light must first be turned on. After pressing the **NIGHT LITE** or **LITE** keypad, press the **TIMER** keypad twice within 3-seconds.

The first press will light the *ENTER* and *TIMER* display, and *TIME* will be displayed.

The second press will cause *TIME* to be cleared from the display, and *LIGHT* to be displayed in its place. The display will remain the same.

Pressing the **TIMER SET** keypad will toggle between the *LIGHT* and *TIMER* displays.

When a numeric keypad is pressed, the display will be cleared, and the number entered will be shown in the display to the far right.

TOUCH PANEL TEST

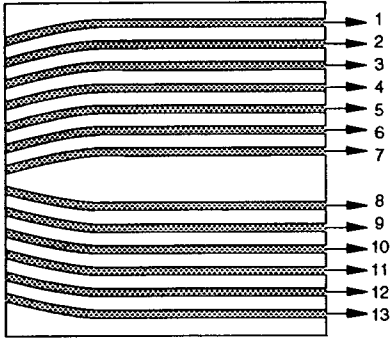
COMPONENT	TEST PROCEDURE	RESULT
<p>Touch the keyboard (see below).</p> <p style="text-align: center;">FPC CONNECTOR (TOP)</p> 	<p>Measure the resistance between the terminal pins of the keypad (shown below) that you wish to check.</p> <p>For example: To measure the "PROBE TEMP" keypad, refer to the illustration, and:</p> <ol style="list-style-type: none"> 1. Find the first terminal number along the top bar (pin 4). 2. Find the second terminal number in the side bar (pin 8). 3. Set the ohmmeter to the $R \times 1$ scale. <p>a) With the keypad not depressed, touch the ohmmeter leads between pins 4 and 8 on the ends of the FPC connector.</p> <p>b) Press the PROBE TEMP keypad.</p>	<p>Normal Readings: KEYPAD NOT PRESSED - Indicates more than 1 MΩ resistance.</p> <p>Normal Readings: KEYPAD PRESSED - Indicates less than 400 Ω resistance.</p> <p>Abnormal Readings: KEYPAD NOT PRESSED - Indicates continuity (zero resistance).</p> <p>Abnormal Readings: KEYPAD PRESSED - Indicates infinite resistance.</p>

CONVENTIONAL MICROWAVE TOUCH PANEL MATRIX

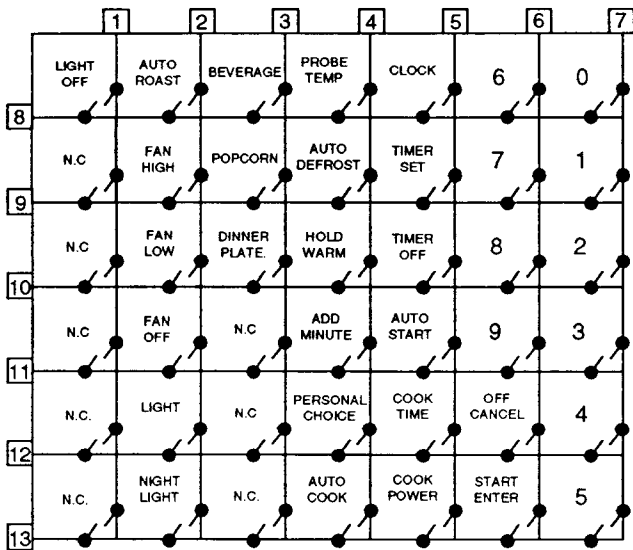

CONVECTION MICROWAVE TOUCH PANEL MATRIX

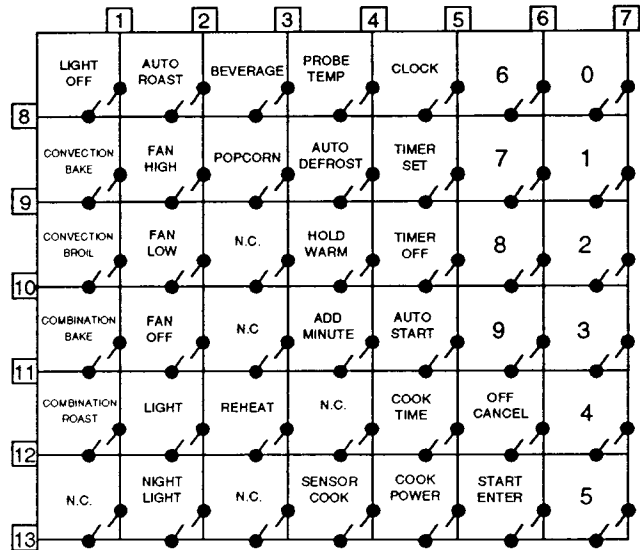

THINGS TO KNOW

COMBINATION BAKE

The combination bake temperature range is 150°F to 450°F. The combination bake time will be limited to a maximum of 199-minutes, 99-seconds.

Access To The Preheat Feature

After the cook time is entered, the **COMBINATION BAKE** keypad must be pressed again within 2-seconds if a preheat is desired.

Preheat

When the **START/enter** keypad is pressed, the *PREHEAT* and *TEMP* display will light, and *LO F* will be displayed until the oven temperature reaches 100°F. After this point is reached, the display will actively show the oven temperature in 5° increments until the “preheat set” temperature is reached.

At that time, the “end of preheat” signal will sound, and the oven temperature will be maintained for 30-minutes, or until the food is placed in the oven and the **START/enter** keypad is pressed.

If the **START/enter** keypad is not pressed within 30-minutes of the “end of preheat” signal, the feature will be terminated.

The “combination bake” cycle will utilize **10% microwave power**, but will not be added until the preheat temperature is reached, if programmed.

REMOVING THE CONTROL PANEL

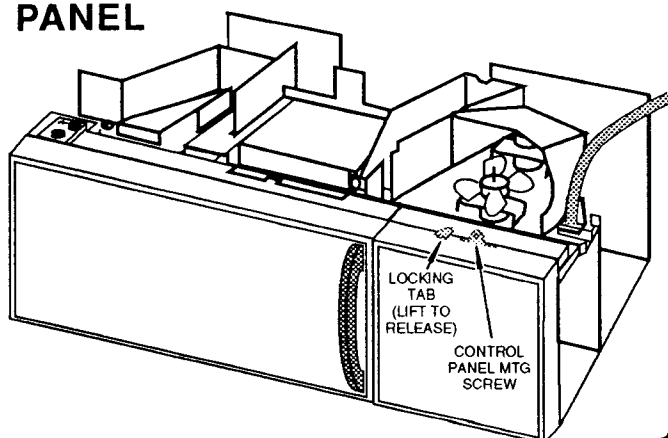

COMBINATION ROAST

The combination roast temperature range is 150°F to 450°F. The combination roast time will be limited to a maximum of 199-minutes and 99-seconds.

Access To The Preheat Feature

After the cook time is entered, the **COMBINATION ROAST** keypad must be pressed again within 2-seconds if a preheat is desired.

Preheat

When the **START/enter** keypad is pressed, the *PREHEAT* and *TEMP* display will light, and *LO F* will be displayed until the oven temperature reaches 150°F. After this point is reached, the display will actively show the oven temperature in 5° increments until the “preheat set” temperature is reached.

At that time, the “end of preheat” signal will sound, and the oven temperature will be maintained for 30-minutes, or until the food is placed in the oven and the **START/enter** keypad is pressed.

If the **START/enter** keypad is not pressed within 30-minutes of the “end of preheat” signal, the feature will be terminated.

The “combination roast” cycle will utilize **20% microwave power**, but will not be added until the preheat temperature is reached, if programmed.

THE TEMPERATURE PROBE

The temperature probe will be inoperative during the “broil” operation, but may be programmed for all other “convection” and “combination” features.

SERVICE MANUALS

OTR Microwave/Convection Oven—
LIT4321659.

OTR Microwave Oven (Conventional)—
LIT4321620.

STRIP CIRCUITS

1. UNIT IS PLUGGED IN — CLOCK IS WORKING

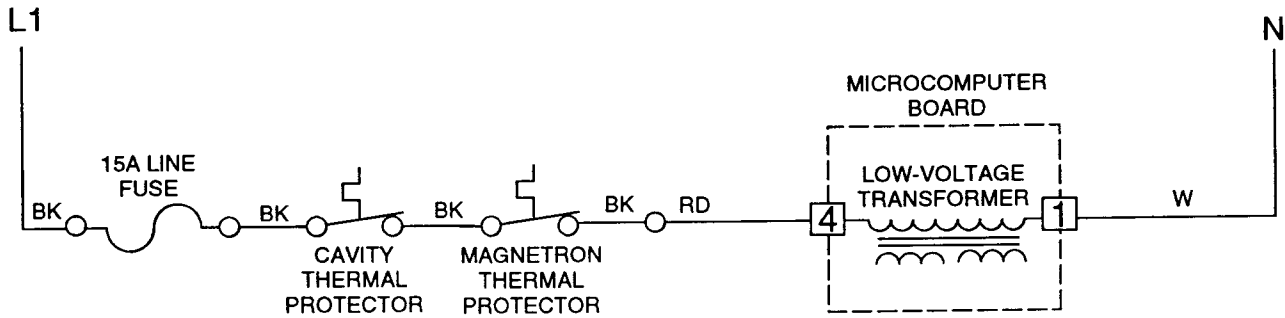

2. DOOR IS OPEN — OVEN LIGHT IS ON

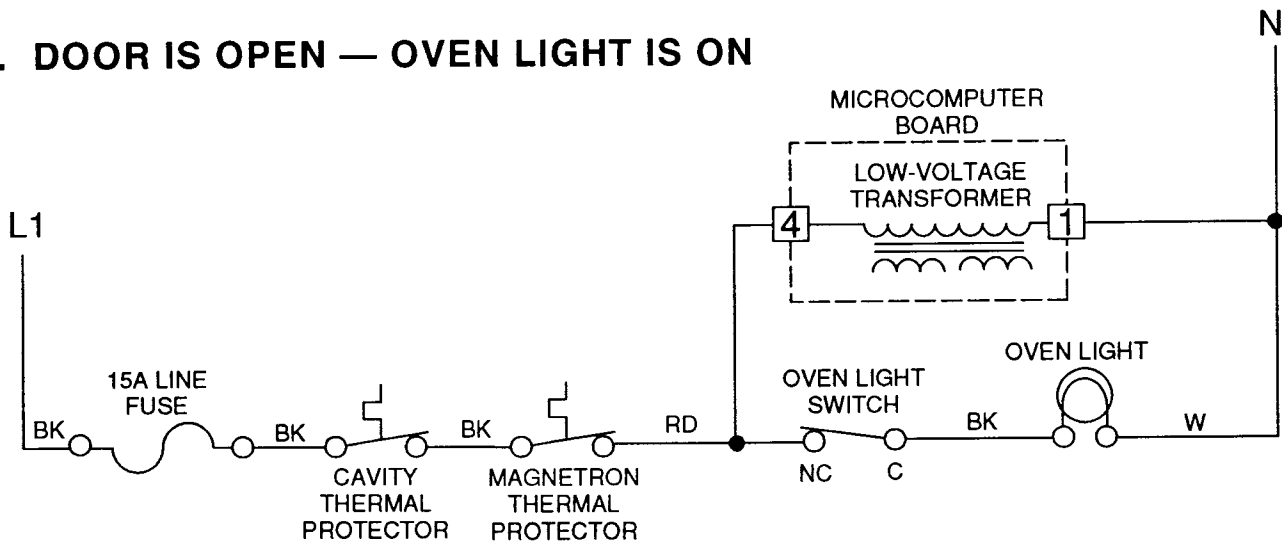

3. BLOWER MOTOR IS ON "LOW"

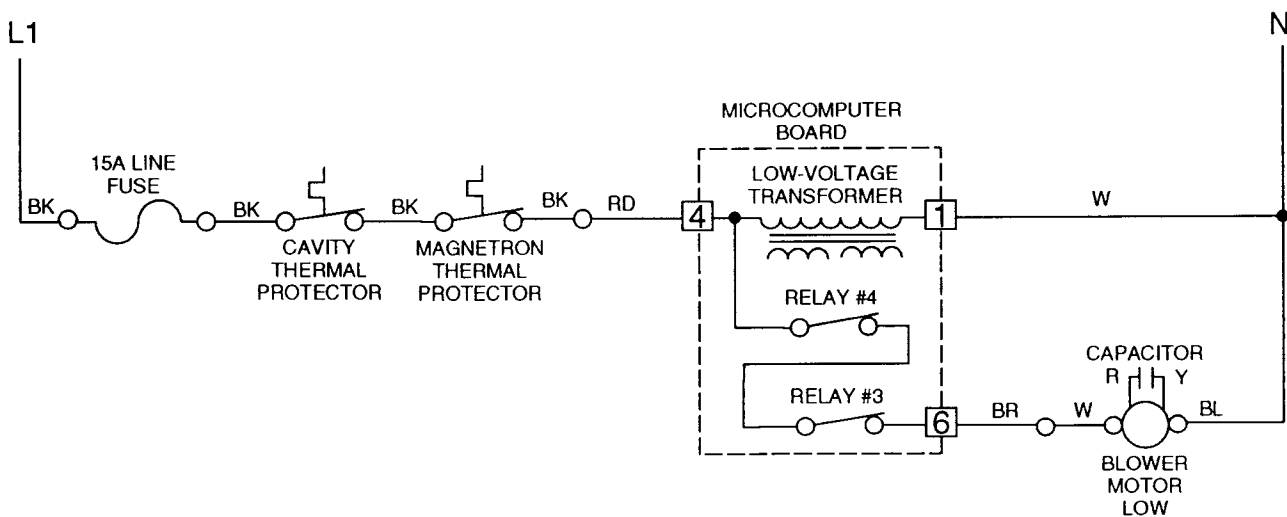

4. BLOWER MOTOR IS ON "HIGH"

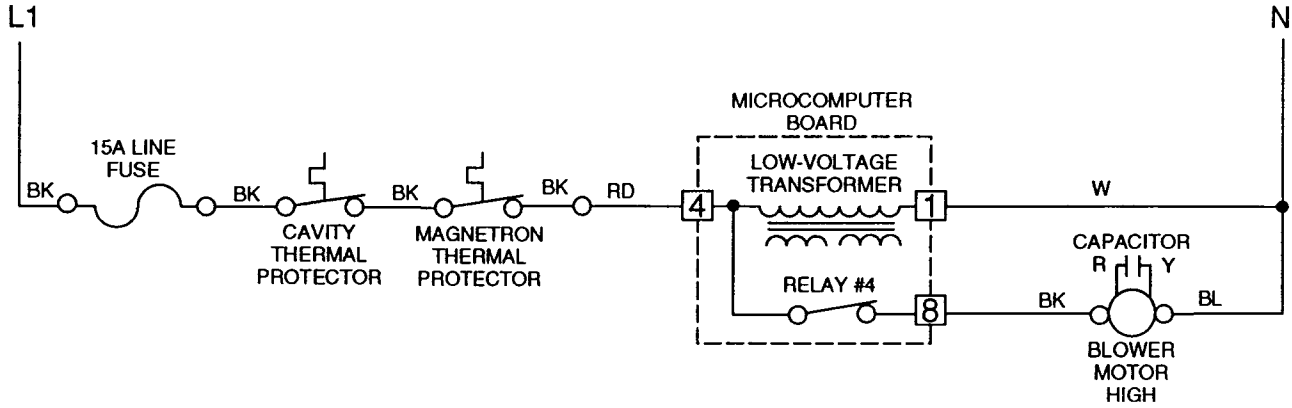

5. COOKTOP LIGHT IS ON "HIGH"

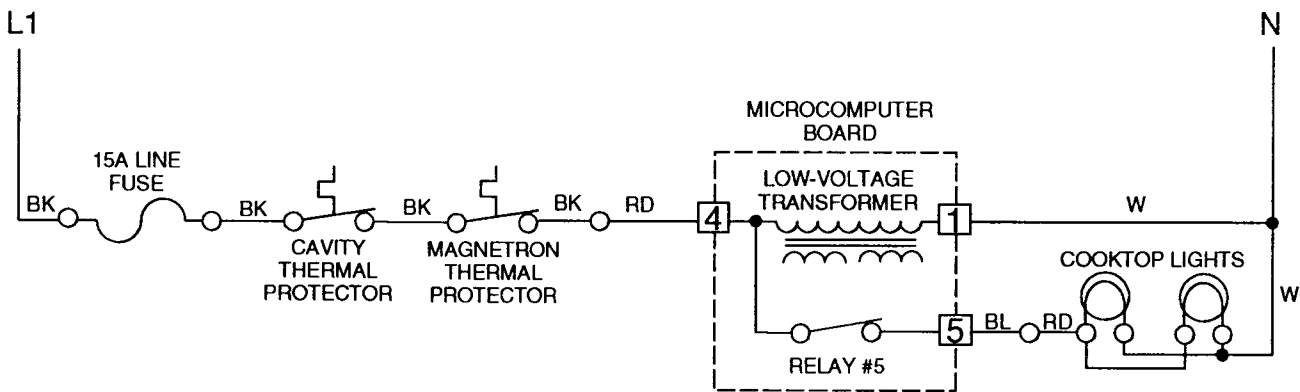

6. COOKTOP LIGHT IS ON "LOW"

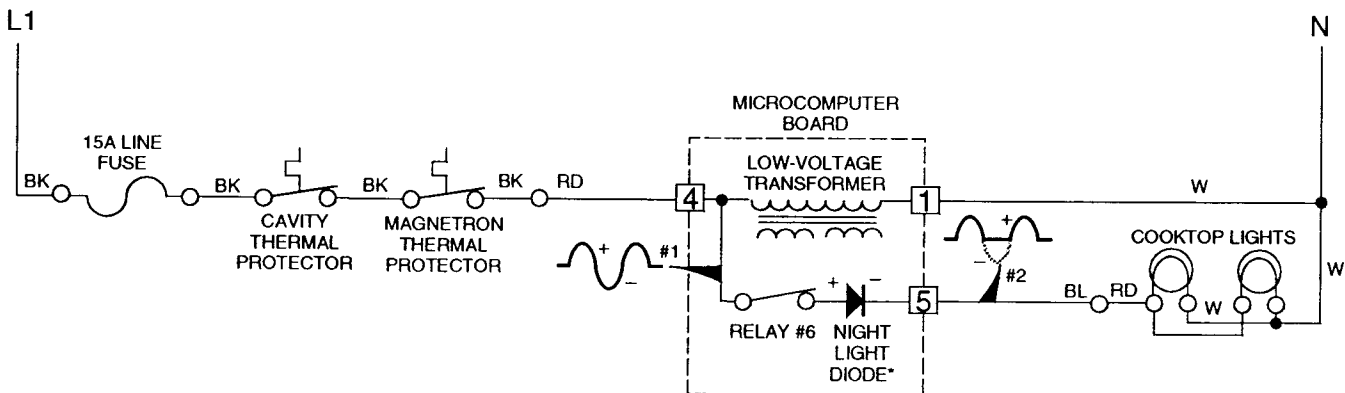

* WHEN RELAY 6 CLOSES, THE AC SIGNAL (SEE WAVEFORM #1) PASSES THROUGH IT TO THE NIGHT LIGHT DIODE. THE DIODE ACTION ALLOWS ONLY THE POSITIVE (+) HALF OF THE SIGNAL TO PASS THROUGH IT (SEE WAVEFORM #2) TO THE COOKTOP LIGHTS, AND REDUCES THE BRIGHTNESS DURING "NIGHT LIGHT" OPERATION.

7. OVEN IS OFF — COOKTOP TEMPERATURE IS ABOVE 133°F BLOWER MOTOR IS ON “LOW”

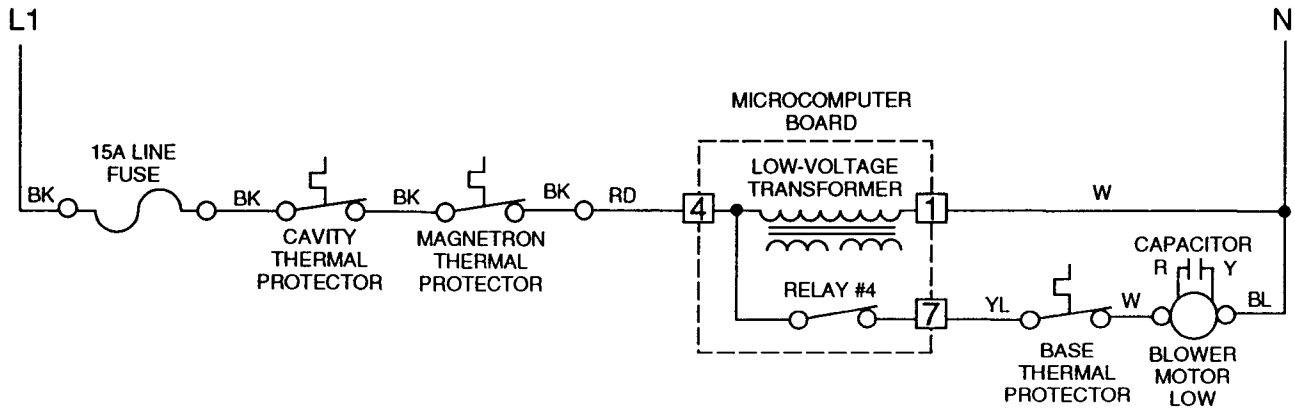

8. MICROWAVE COOKING IS ON

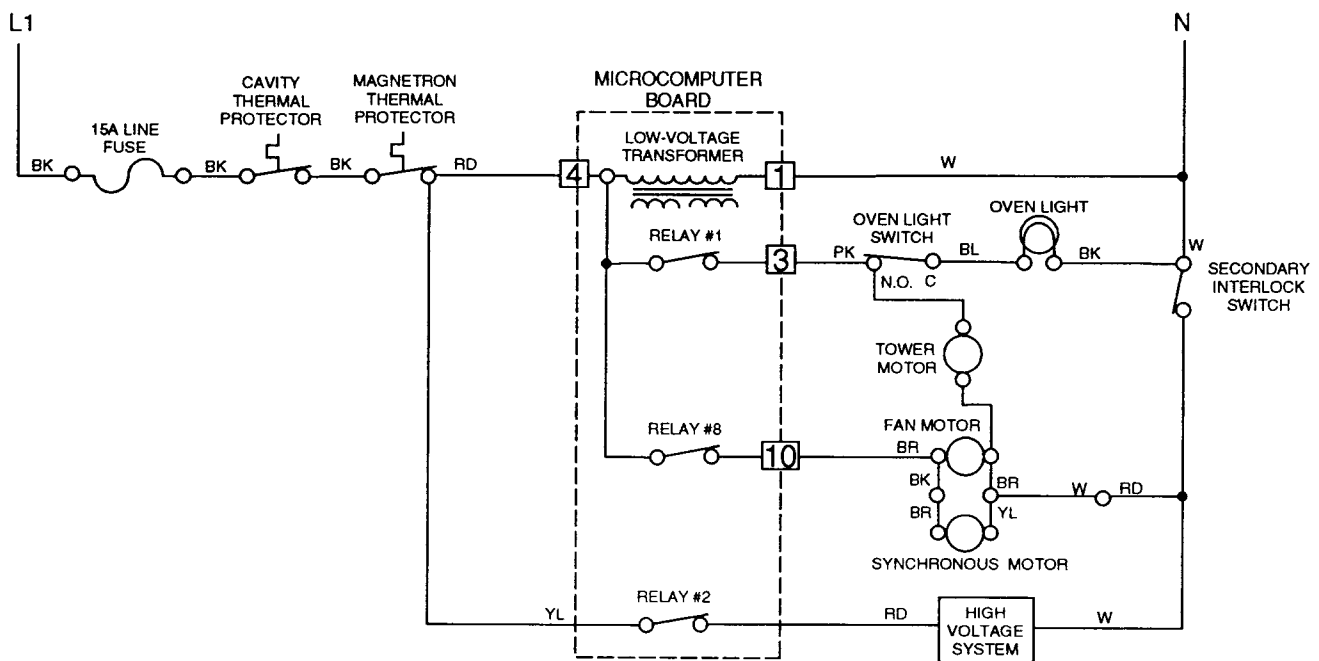

9. CONVECTION COOKING IS ON

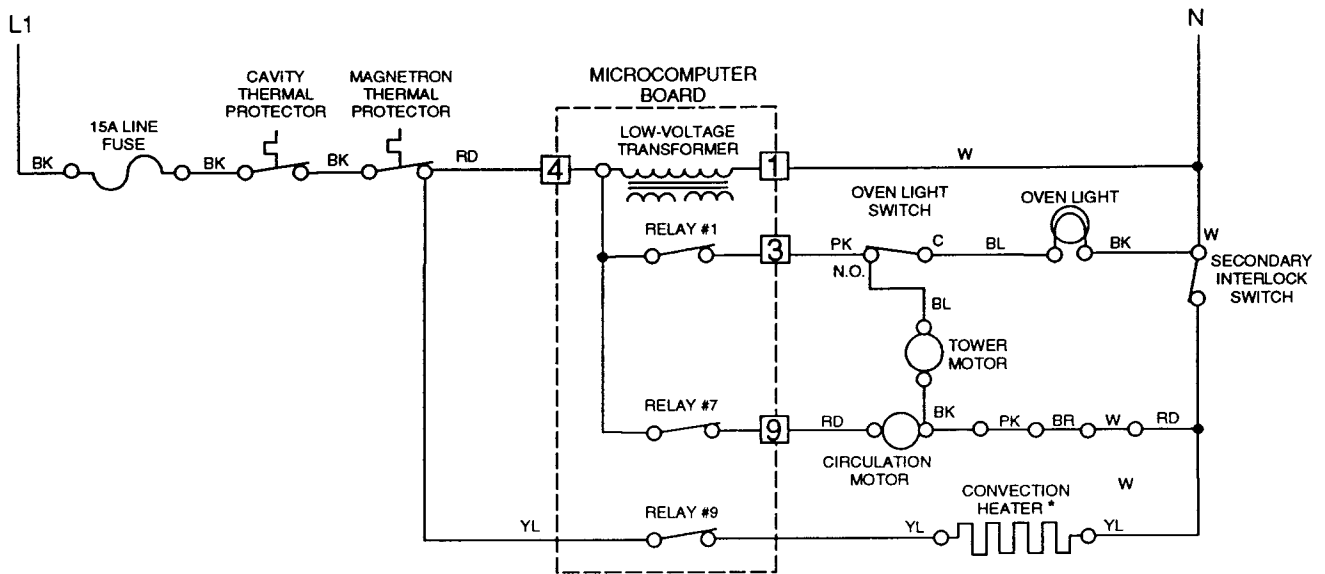

* Heater cycling is controlled by the convection thermistor.

SKILLS CHECK

1. In the "convection" mode, the bake temperature range is between 150°F and 450°F. How does the OTR microwave/convection oven maintain the selected temperature?

2. List all of the motors used in the OTR microwave/convection oven, and give a brief description of their functions.

3. Which motor(s) is(are) used during the microwave "cook" function of the OTR microwave/convection oven?

4. The cooktop light operates on either HIGH or LOW. How do the lighting circuits provide the two light intensities?

5. At what temperature does the blower motor turn on automatically? _____

At what temperature does the blower motor turn off automatically? _____

6. How does the microwave energy enter the oven cavity, and how is it distributed?

7. How much microwave power is used during COMBINATION BAKE? _____

How much microwave power is used during COMBINATION ROAST? _____

8. When using the "safety lock" feature, all keypads are disabled except the:

9. What relay on the microcomputer board is used to energize the circulation motor?

10. What error code will be displayed if the gas sensor is not working properly?

SKILLS CHECK ANSWERS

1. The thermistor cycles the convection heating element on and off to regulate the temperature.
2. **Blower Motor**—Removes smoke and odors from the kitchen cooking area through outside venting or recirculation of the air.
Circulation Motor—Circulates heated air inside the oven during convection cooking.
Tower Motor—Circulates air through the electrical section of the oven during microwave and convection cooking to cool it.
Fan Motor—Cools the magnetron and circulates air through the oven during microwave cooking.
Synchronous Motor—Distributes microwave energy into the oven during microwave cooking.
3. Tower, fan, & synchronous motors.
4. A diode in the night-light circuit cuts the AC voltage, reducing the light intensity.
5. On at 133°F & Off at 104°F.
6. Microwave energy enters the bottom of the oven cavity and is distributed by a rotating distribution plate.
7. 10% for Bake & 20% for Roast.
8. Exhaust fan (high & low) & Cooktop light (Night Lite & Lite) pad #3.
9. Relay #7.
10. F1.

