

# VIKING

## SERVICE MANUAL

S32M340RDM6SS

### OVER THE RANGE MICROWAVE OVEN



**MODEL**  
**RDMOR206SS**

In the interest of user-safety, the oven should be restored to its original condition and only parts identical to those specified should be used.

**WARNING TO SERVICE PERSONNEL:** Microwave ovens contain circuitry capable of producing very high voltage and current, contact with following parts may result in a severe, possibly fatal, electrical shock. (High Voltage Capacitor, High Voltage Power Transformer, Magnetron, High Voltage Rectifier Assembly, High Voltage Harness etc..)

#### TABLE OF CONTENTS

	Page
PRECAUTIONS TO BE OBSERVED BEFORE AND DURING SERVICING TO AVOID POSSIBLE EXPOSURE TO EXCESSIVE MICROWAVE ENERGY .....	INSIDE FRONT COVER
BEFORE SERVICING .....	INSIDE FRONT COVER
MICROWAVE MEASUREMENT PROCEDURE.....	4
WARNING TO SERVICE PERSONNEL.....	6
FOREWORD AND WARNING .....	7
PRODUCT SPECIFICATIONS .....	8
GENERAL INFORMATION.....	8
OPERATION.....	11
TROUBLESHOOTING GUIDE .....	19
TEST PROCEDURE .....	22
COMPONENT REPLACEMENT AND ADJUSTMENT PROCEDURE.....	34
PICTORIAL DIAGRAM .....	43

# VIKING

Range Corporation  
111 Front St., Greenwood, MS 38930  
Tel: (888) 845-4641

This document has been published to be used for after sales service only. The contents are subject to change without notice.

SMC-0027

## **PRECAUTIONS TO BE OBSERVED BEFORE AND DURING SERVICING TO AVOID POSSIBLE EXPOSURE TO EXCESSIVE MICROWAVE ENERGY**

- (a) Do not operate or allow the oven to be operated with the door open.
- (b) Make the following safety checks on all ovens to be serviced before activating the magnetron or other microwave source, and make repairs as necessary: (1) interlock operation, (2) proper door closing, (3) seal and sealing surfaces (arcing, wear, and other damage), (4) damage to or loosening of hinges and latches, (5) evidence of dropping or abuse.
- (c) Before turning on microwave power for any service test or inspection within the microwave generating compartments, check the magnetron, wave guide or transmission line, and cavity for proper alignment, integrity, and connections.
- (d) Any defective or misadjusted components in the interlock, monitor, door seal, and microwave generation and transmission systems shall be repaired, replaced, or adjusted by procedures described in this manual before the oven is released to the owner.
- (e) A microwave leakage check to verify compliance with the Federal Performance Standard should be performed on each oven prior to release to the owner.

## **BEFORE SERVICING**

Before servicing an operative unit, perform a microwave emission check as per the Microwave Measurement Procedure outlined in this service manual.

If microwave emissions level is in excess of the specified limit, contact Viking Service immediately @ 1-888-845-4641.

If the unit operates with the door open, service person should (1) tell the user not to operate the oven and (2) contact VIKING, plus the Department Of Health, Canada and/or the Food and Drug Administration's Center for Devices and Radiological Health immediately.

Service personnel should inform VIKING of any certified unit found with emissions in excess of 4mW/cm<sup>2</sup>. The owner of the unit should be instructed not to use the unit until the oven has been brought into compliance.

## **DANGER CAUTION HIGH VOLTAGE**

Do not energize a microwave oven with the outer case cabinet removed, because a microwave oven generates High Voltage in the circuit.

If you intend to operate the oven employing the high frequency switching power converter circuit, you should take special precautions to avoid an electrical shock hazard.

The high voltage transformer, high voltage capacitor and high voltage diode have energized high voltage potential approx. 8 KV.

The aluminium heat sink is connected to the switching power transistor Collector pole, and has an energized high voltage potential approx. 650V peak.

**DO NOT ACCESS THE HIGH VOLTAGE TRANSFORMER, HIGH VOLTAGE CAPACITOR, HIGH VOLTAGE DIODE AND HEAT SINK WHEN THE POWER SUPPLY IS CONNECTED TO AN ELECTRICAL OUTLET.**

# Notes

## MICROWAVE MEASUREMENT PROCEDURE (USA)

### A. Requirements:

- 1) Microwave leakage limit (Power density limit): The power density of microwave radiation emitted by a microwave oven should not exceed  $1\text{mW}/\text{cm}^2$  at any point 5cm or more from the external surface of the oven, measured prior to acquisition by a purchaser, and thereafter (through the useful life of the oven),  $5\text{mW}/\text{cm}^2$  at any point 5cm or more from the external surface of the oven.
- 2) Safety interlock switches Primary interlock relay and door sensing switch shall prevent microwave radiation emission in excess of the requirement as above mentioned, secondary interlock switch shall prevent microwave radiation emission in excess of  $5\text{mW}/\text{cm}^2$  at any point 5cm or more from the external surface of the oven.

### B. Preparation for testing:

#### Before beginning the actual measurement of leakage, proceed as follows:

- 1) Make sure that the actual instrument is operating normally as specified in its instruction booklet.

#### Important:

Survey instruments that comply with the requirement for instrumentation as prescribed by the performance standard for microwave ovens, 21 CFR 1030.10(c)(3)(i), must be used for testing.

- 2) Place the oven tray in the oven cavity.
- 3) Place the load of  $275\pm 15$  ml (9.8 oz) of tap water initially at  $20\pm 5\frac{1}{2}\text{C}$  ( $68\frac{1}{2}\text{F}$ ) in the center of the oven cavity. The water container shall be a low form of 600 ml (20 oz) beaker with an inside diameter of approx. 8.5 cm (3-1/2 in.) and made of an electrically nonconductive material such as glass or plastic. The placing of this standard load in the oven is important not only to protect the oven, but also to insure that any leakage is measured accurately.
- 4) Set the cooking control on Full Power Cooking Mode
- 5) Close the door and select a cook cycle of several minutes. If the water begins to boil before the survey is completed, replace it with 275 ml of cool water.

### C. Leakage test:

#### Closed-door leakage test (microwave measurement)

- 1) Grasp the probe of the survey instrument and hold it perpendicular to the gap between the door and the body of the oven.
- 2) Move the probe slowly, not faster than 1 in./sec. (2.5 cm/sec.) along the gap, watching for the maximum indication on the meter.
- 3) Check for leakage at the door screen, sheet metal seams and other accessible positions where the continuity of the metal has been breached (eg., around the switches, indicator, and vents). While testing for leakage around the door pull the door away from the front of the oven as far as is permitted by the closed latch assembly.
- 4) Measure carefully at the point of highest leakage and make sure that the highest leakage is no greater than  $4\text{mW}/\text{cm}^2$ , and that the secondary interlock switch does turn the oven OFF before any door movement.

NOTE: After servicing, record data on service invoice and microwave leakage report.

## MICROWAVE MEASUREMENT PROCEDURE (CANADA)

After adjustment of the door switches are completed individually or collectively, switch test and microwave leakage test must be performed with survey instrument and test result must be confirmed to meet the requirement of the performance standard

for microwave ovens as undermentioned.

### A. Requirements:

Every microwave oven shall function in such a manner that when the oven is fully assembled and operating with its service controls and user controls adjusted to yield the maximum output, the leakage radiation, at all points at least 5 cm. from the external surface of the oven, does not exceed:

- 1) 1.0mW/cm<sup>2</sup> with the test load of 275 ± 15 ml of water at an initial temperature 20 ±5°C.
- 2) 5.0mW/cm<sup>2</sup> when the outer enclosure is removed with a test load of 275 ± 15 ml of water at an initial temperature 20±5°C.
- 3) 5.0mW/cm<sup>2</sup> without a test load.

### B. Preparation for testing:

**Before beginning the actual measurement of leakage, proceed as follows:**

- 1) Make sure that the actual instrument is operating normally as specified in its instruction booklet.

Important:

Survey instruments that comply with the requirement for instrumentation as prescribed by CSA and NHW performance standard for microwave ovens must be used for testing recommended instruments are , NARDA 8100 and NARDA 8200.

- 2) Place the oven tray in the oven cavity.
- 3) Place the load of 275±15 ml of tap water initially at 20±5°C in the center of the oven cavity.  
The water container shall be a low form of 600 ml beaker with an inside diameter of approx. 8.5 cm (3-1/2 in.) and made of an electrically nonconductive material such as glass or plastic.  
The placing of this standard load in the oven is important not only to protect the oven, but also to insure that any leakage is measured accurately.
- 4) Set the cooking control on Full Power Cooking Mode, Close the door and select a cook cycle of several minutes. If the water begins to boil before the survey is completed, replace it with 275 ml of cool water.

### C. Leakage test with enclosure installed :

- 1) Grasp the probe of the survey instrument and hold it perpendicular to the gap between the door and the body of the oven.
- 2) Move the probe slowly, not faster than 2.5 cm/sec. along the gap, watching for the maximum indication on the meter.
- 3) Check for leakage at the door screen, sheet metal seams and other accessible positions where the continuity of the metal has been breached (eg., around the switches, indicator, and vents).  
While testing for leakage around the door pull the door away from the front of the oven as far as is permitted by the closed latch assembly.
- 4) Measure carefully at the point of highest leakage and make sure that the highest leakage is no greater than 4mW/cm<sup>2</sup>, and that the secondary interlock switch does turn the oven OFF before any door movement.

### C. Leakage test without enclosure:

- 1) Remove the enclosure (cabinet).
- 2) Grasp the probe of the survey instrument and hold it perpendicular to all mechanical and electric parts of the oven that is accessible to the user of the oven including, but not limited to, the waveguide, cavity seams, magnetron gap between the door and the body of the oven.
- 3) Move the probe slowly, not faster than 2.5 cm/sec. along the gap, watching for the maximum indication on the meter.
- 4) Measure carefully at the point of highest leakage and make sure that the highest leakage is under 5mW/cm<sup>2</sup>.

**CAUTION:** Special attention should be given to avoid electrical shock because HIGH VOLTAGE is generated during this test

### No Load test

- 1) Operate the oven without a load and measure the leakage by the same method as the above test procedure " Leakage test with enclosure installed"
2. Make sure that the highest leakage should not exceed 5mW/cm<sup>2</sup>.

NOTE: After servicing, record data on service invoice and microwave leakage report.

## WARNING TO SERVICE PERSONNEL

Microwave ovens contain circuitry capable of producing very high voltage and current, contact with following parts may result in a severe, possibly fatal, electrical shock.

(Example)

High Voltage Capacitor, High Voltage Power Transformer, Magnetron, High Voltage Rectifier Assembly, High Voltage Harness etc..

Read the Service Manual carefully and follow all instructions.

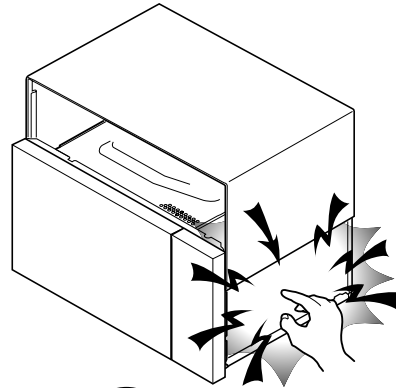

**Don't Touch !  
Danger High Voltage**

### Before Servicing

1. Disconnect the power supply cord  and then remove outer case.
2. Open the door and block it open.
3. Discharge high voltage capacitor.

#### **WARNING: RISK OF ELECTRIC SHOCK. DISCHARGE THE HIGH-VOLTAGE CAPACITOR BEFORE SERVICING.**

The high-voltage capacitor remains charged about 60 seconds after the oven has been switched off. Wait for 60 seconds and then short-circuit the connection of the high-voltage capacitor (that is the connecting lead of the high-voltage rectifier) against the chassis with the use of an insulated screwdriver.

Whenever troubleshooting is performed the power supply must be disconnected. It may in, some cases, be necessary to connect the power supply after the outer case has been removed, in this event,

1. Disconnect the power supply cord, and then remove outer case.
2. Open the door and block it open.
3. Discharge high voltage capacitor.
4. Disconnect the leads to the primary of the power transformer.
5. Ensure that these leads remain isolated from other components and oven chassis by using insulation tape.
6. After that procedure, reconnect the power supply cord.

#### **When the testing is completed,**

1. Disconnect the power supply cord, and then remove outer case.

2. Open the door and block it open.
3. Discharge high voltage capacitor.
4. Reconnect the leads to the primary of the power transformer.
5. Reinstall the outer case (cabinet).
6. Reconnect the power supply cord after the outer case is installed.
7. Run the oven and check all functions.

### After repairing

1. Reconnect all leads removed from components during testing.
2. Reinstall the outer case (cabinet).
3. Reconnect the power supply cord after the outer case is installed.
4. Run the oven and check all functions.

Microwave ovens should not be run empty. To test for the presence of microwave energy within a cavity, place a cup of cold water on the oven turntable, close the door and set the power to HIGH and set the microwave timer for two (2) minutes. When the two minutes has elapsed (timer at zero) carefully check that the water is now hot. If the water remains cold carry out **Before Servicing** procedure and re-examine the connections to the component being tested.

When all service work is completed and the oven is fully assembled, the microwave power output should be checked and microwave leakage test should be carried out.

# SERVICE MANUAL

## VIKING RANGE CORPORATION

### MICROWAVE OVEN

RDMOR206SS

### FOREWORD

This Manual has been prepared to provide Viking Service Personnel with Operation and Service Information for the VIKING MICROWAVE OVEN.

It is recommended that service personnel carefully study the entire text of this manual and the base model's manual so that they will be qualified to render satisfactory customer service.

Check the interlock switches and the door seal carefully. Special attention should be given to avoid electrical shock and microwave radiation hazard.

#### WARNING

Never operate the oven until the following points are ensured:

- (A) The door is tightly closed.
- (B) The door brackets and hinges are not defective.
- (C) The door packing is not damaged.
- (D) The door is not deformed or warped.
- (E) There is no other visible damage with the oven.

Servicing and repair work must be carried out only by trained service personnel.

#### DANGER

**Certain initial parts are intentionally not grounded and present a risk of electrical shock only during servicing. Service personnel - Do not contact the following parts while the appliance is energized;**

**High Voltage Capacitor, Power Transformer, Magnetron, High Voltage Rectifier Assembly, High Voltage Harness;  
If provided, Vent Hood, Fan assembly, Cooling Fan Motor.**

All the parts marked "\*" on parts list are used at voltages more than 250V.

Removal of the outer wrap gives access to voltage above 250V.

PRODUCT DESCRIPTION

GENERAL INFORMATION

OPERATION

TROUBLESHOOTING GUIDE AND  
TEST PROCEDURE

COMPONENT REPLACEMENT  
AND ADJUSTMENT PROCEDURE

WIRING DIAGRAM

**VIKING RANGE CORPORATION**

111 Front St., Greenwood, MS 38930

Tel: (888) 845-4641

## SPECIFICATION

ITEM	DESCRIPTION
Power Requirements	120 Volts / 13.2 Amperes (Microwave), 13.2 Amperes (Convection) - [UL Rating] 116 Volts / 13.2 Amperes (Microwave), 13.2 Amperes (Convection) - [CSA Rating] 60 Hertz Single phase, 3 wire grounded
Power Output	850 watts (IEC-705 TEST PROCEDURE) Operating frequency of 2450MHz
Convection Power Output	1400 watts
Case Dimensions	Width 29-15/16" Height 16-11/32" Depth 15- 9/32"
Cooking Cavity Dimensions	Width 17-1/8" Height 8-1/16" Depth 13-13/16"
1.1 Cubic Feet	
Hood lamps (2)	1 bulb @ 20W & 1 bulb @ 40W
Hood fan	Horizontal discharge 230 C.F.M. , Vertical discharge 240 C.F.M. Low Speed 235 cfms, High Speed 300 cfms
Control Complement	Touch Control System Clock ( 1:00 - 12:59 ) Timer (0 - 99 min. 99 seconds) Microwave Power for Variable Cooking Repetition Rate; P-HI ..... Full power throughout the cooking time P-90..... approx. 90% of Full Power P-80..... approx. 80% of Full Power P-70..... approx. 70% of Full Power P-60..... approx. 60% of Full Power P-50..... approx. 50% of Full Power P-40..... approx. 40% of Full Power P-30 ..... approx. 30% of Full Power P-20..... approx. 20% of Full Power P-10..... approx. 10% of Full Power P-0..... No power throughout the cooking time  Help pad, Sensor Cook pad, Auto Broil pad, Auto Roast pad Auto Bake pad, Sensor Reheat pad, More Time pad, Popcorn pad Timed Defrost pad, Convection pad, Preheat pad, Combination Bake pad Combination Roast pad, Broil pad, Slow Cook pad, Timer pad Number and temperature selection pads, Clock pad, Hold Warm pad Turntable On / Off pad, Power Level pad, Stop/Clear pad, Start / Touch On pad, Fan Hi/Lo/Off, Light.
Oven Cavity Light	Yes 20W x 1 Incandescent light bulb
Safety Standard	UL Listed FCC Authorized DHHS Rules, CFR, Title 21, Chapter 1, Subchapter J Canadian Standards Association. Health CANADA, Industry CANADA.
Weight	Approx. 71 lbs.

## GENERAL INFORMATION

### GROUNDING INSTRUCTIONS

This oven is equipped with a three prong grounding plug. It must be plugged into a wall receptacle that is properly installed and grounded in accordance with the National Electrical Code and local codes and ordinances.

In the event of an electrical short circuit, grounding reduces the risk of electric shock by providing an escape wire for the electric current.

**WARNING: Improper use of the grounding plug can result in a risk of electric shock.**



## Electrical Requirements

The oven is equipped with a 3-prong grounding plug. **DO NOT UNDER ANY CIRCUMSTANCES CUT OR REMOVE THE GROUNDING PIN FROM THE PLUG.**

The power supply cord and plug must be connected to a separate 120 Volt AC, 60 Hz, 15 Amp. or more branch circuit, using a grounded receptacle. The receptacle should be located inside the cabinet directly above the Microwave Oven/Hood system mounting location.

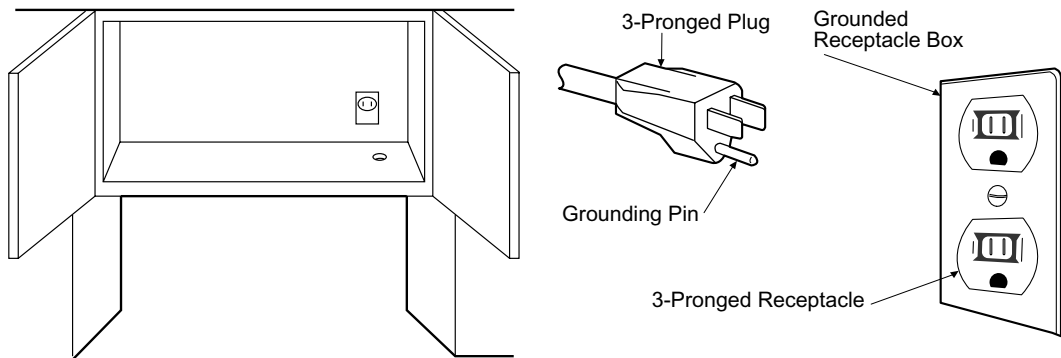

## OVEN DIAGRAM

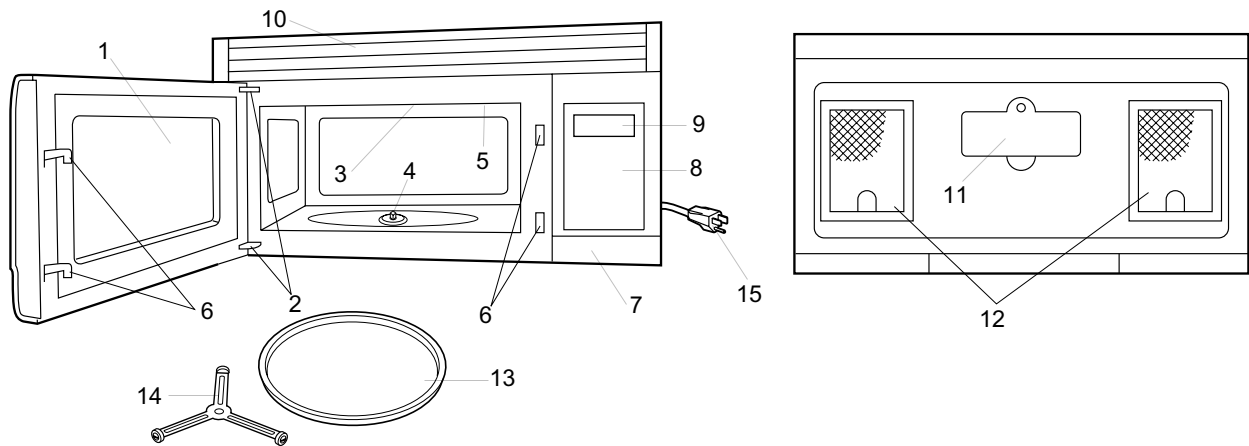

1. Oven door with see-through window.
2. Door hinges.
3. Sirror cover.
4. Turntable motor shaft.
5. Oven lamp.  
It will light when oven is operating or door is open.
6. Door latches.  
The oven will not operate unless the door is securely closed.
7. One touch door open button.  
Push to open door.
8. Auto-Touch control panel.
9. Time display: Digital display, 99 minutes 99 seconds.
10. Ventilation openings.
11. Light Cover.
12. Grease filters.
13. Removable turntable.  
The turntable will rotate clockwise or counterclockwise.  
Only remove for cleaning.
14. Removable turntable support.
15. Plug

## CONTROL PANEL

**NOTE:**

Some one-touch cooking features as "Add-a-Minute " are disabled after one minute when the oven is not used. These features are automatically enabled when the door is opened and closed or the STOP/CLEAR pad s are pressed.

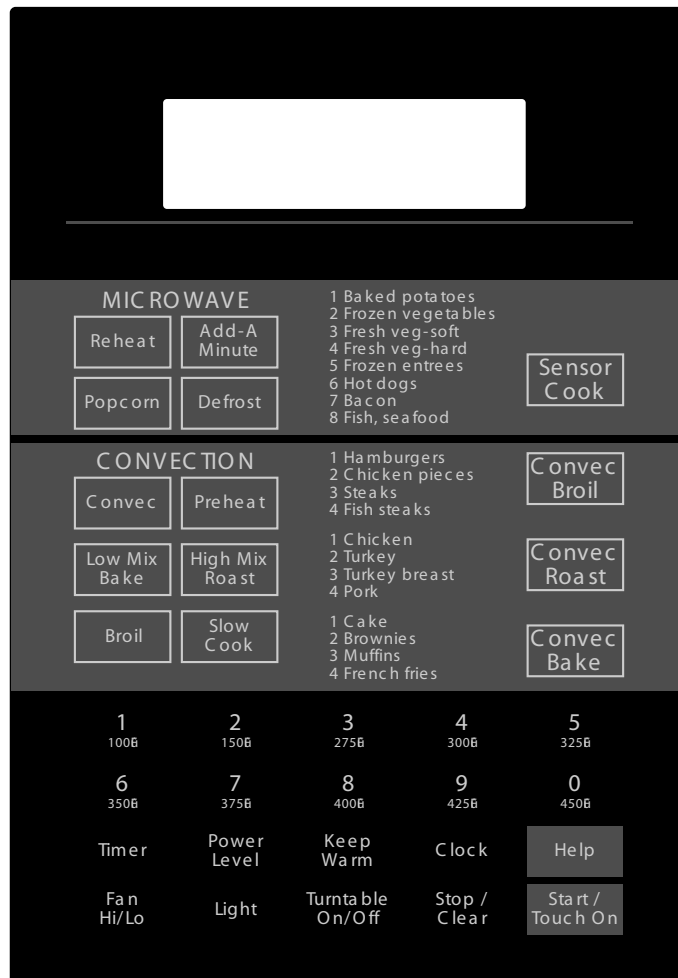

## OPERATION

### DESCRIPTION OF OPERATING SEQUENCE

The following is a description of component functions during oven operation.

#### OFF CONDITION

Closing the door activates the door sensing switch and secondary interlock switch. (In this condition, the monitor switch contacts are opened.)

When oven is plugged in, 120 volts A.C. is supplied to the control unit. (Figure O-1).

1. The display will show "Welcome".

To set any program or set the clock, you must first touch the STOP/CLEAR pad. The display will clear, and " : " will appear.

#### COOKING CONDITION

Program desired cooking time touching the NUMBER pads. When the START pad is touched, the following operations occur:

1. The contacts of relays are closed and components connected to the relays are turned on as shown on **page 29**.
2. 120 volts A.C. is supplied to the primary winding of the power transformer and is converted to about 3.3 volts A.C. output on the filament winding, and approximately 2000 volts A.C. on the high voltage winding.
3. The filament winding voltage heats the magnetron filament and the H.V. winding voltage is sent to a voltage doubler circuit.
4. The microwave energy produced by the magnetron is channelled through the waveguide into the cavity feed-box, and then into the cavity where the food is placed to be cooked.
5. Upon completion of the cooking time, the power transformer, oven lamp, etc. are turned off, and the generation of microwave energy is stopped. The oven will revert to the OFF condition.
6. When the door is opened during a cook cycle, monitor switch, door sensing switch, secondary switch and third door switch and primary interlock relay are activated with the following results. The circuits to the stirrer motor, the cooling fan motor, the turntable motor, and the high voltage components are de-energized, and the digital read-out displays the time still remaining in the cook cycle when the door was opened.
7. The monitor switch is electrically monitoring the operation of the secondary and third door door switch and primary interlock relay and is mechanically associated with the door so that it will function in the following sequence.
  - (1) When the door opens from a closed position, the primary interlock relay, door sensing switch, secondary and third door switch open their contacts, and then the monitor switch contacts close.
  - (2) When the door is closed from the open position, the monitor switch contacts first open, and then the contacts of the secondary and third door switch close.

If the primary switch, secondary switch and secondary interlock relay fail with their contacts closed when the door is

opened, the closing of the monitor switch contacts will form a short circuit through the monitor fuse, secondary switch, third door switch and primary interlock relay, causing the monitor fuse to blow.

#### POWER LEVEL P-0 TO P-90 COOKING

When Variable Cooking Power is programmed, the 120 volts A.C. is supplied to the power transformer intermittently through the contacts of relay (RY2) which is operated by the control unit within an interval second time base. Microwave power operation is as follows:

VARI-MODE	ON TIME	OFF TIME
Power 10(P-HI) (100% power)	32 sec.	0 sec.
Power 9(P-90) (approx. 90% power)	30 sec.	2 sec.
Power 8(P-80) (approx. 80% power)	26 sec.	6 sec.
Power 7(P-70) (approx. 70% power)	24 sec.	8 sec.
Power 6(P-60) (approx. 60% power)	22 sec.	10 sec.
Power 5(P-50) (approx. 50% power)	18 sec.	14 sec.
Power 4(P-40) (approx. 40% power)	16 sec.	16 sec.
Power 3(P-30) (approx. 30% power)	12 sec.	20 sec.
Power 2(P-20) (approx. 20% power)	8 sec.	24 sec.
Power 1(P-10) (approx. 10% power)	6 sec.	26 sec.
Power 0(P-0) (0% power)	0 sec.	32 sec.

Note: The ON/OFF time ratio does not correspond with the percentage of microwave power, because approx. 2 seconds are needed for heating of the magnetron filament.

#### CONVECTION COOKING CONDITION

##### PREHEATING CONDITION

Program desired convection temperature by touching the PREHEAT pad and the temperature pad.

When the START pad is touched, the following operations occur:

1. The coil of shut-off relays (RY1, RY4, RY5 and RY7) are energized, the oven lamp, turntable motor, cooling fan motor and convection motor are turned on.
2. The coil of relay (RY6) is energized by the control unit. The damper is moved to the closed position, opening the damper switch contacts. The opening of the damper switch contacts sends a signal to the LSI on the control unit de-energizing the relay (RY6) and opening the circuit to the damper motor.
3. The coil of heater relay (RY3) is energized by the control unit and the main supply voltage is applied to the heating element.
4. When the oven temperature reaches the selected preheat temperature, the following operations occur:
  - 4-1 The heater relay is de-energized by the control unit temperature circuit and thermistor, opening the circuit to the heating element.
  - 4-2. The oven will continue to function for 30 minutes, turning the heater on and off, as needed to maintain the selected preheat temperature. The oven will shutdown completely after 30 minutes

### CONVECTION COOKING CONDITION

When the preheat temperature is reached, a beep signal will sound indicating that the holding temperature has been reached in the oven cavity. Open the door and place the food to be cooked in the oven.

Program convection temperature and desired cooking time by touching the CONVECT pad, Temperature pad and NUMBER pad.

When the START pad is touched, the following operations occur:

1. The numbers on the digital read-out start to count down to zero.
2. The oven lamp, turntable motor, cooling fan motor and convection motor are energized.
3. Heater relay (RY3) is energized (if the cavity temperature is lower than the selected temperature) and the main supply voltage is applied to the heating element to return to the selected cooking temperature.
4. Upon completion of the cooking time, the audible signal will sound, and oven lamp, turntable motor, cooling fan motor and convection motor are de-energized. At the end of the convection cycle, if the oven temperature is above 275° F, the circuit to RY5 will be maintained (by the thermistor circuit) to continue operation of the cooling fan motor until the temperature drops below 245 °F, at which time the relay will be de-energized, turning off the fan motor. Relay RY7 will however, open as soon as the convection cycle has ended, turning off the convection motor.
5. At the end of the convection cook cycle, shut-off relay (RY6) is energized turning on the damper motor. The damper is returned to the open position, closing the damper switch contacts which send a signal to the control unit, de-energizing shut-off relay (RY6).

### AUTOMATIC MIX COOKING CONDITION

Touch the Combination Bake or Combination Roast pad. The LOW MIX/BAKE pad is preprogrammed for 325 °F with 10% microwave power, while the HIGH MIX/ROAST pad is preprogrammed for 325° F with 30% microwave power. Program desired cooking time. When the START pad is touched, the following operations occur:

1. The numbers on the digital read-out start to count down

to zero.

2. The shut-off relays (RY1, RY4, RY5 and RY7) are energized, turning on the oven lamp, turntable motor, cooling fan motor and convection motor.
3. The shut-off relay (RY6) is energized. The damper plate is closed from the open position.
4. The heater relay (RY3) is energized, applying the main supply voltage to the heating element.
5. Now, the oven is in the convection cooking condition.
6. When the oven temperature reaches the selected temperature, the following operations occur:
  - 6-1. The power supply voltage is alternated to the heating element and power transformer.
  - 6-2. The heating element operates through the heater relay (RY3) contacts and the power transformer operates through the primary interlock relay (RY2) contacts.
  - 6-3. These are operated by the control unit to supply alternately within a 32 second time base, convection heat and microwave energy.

The relationship between the convection and microwave power operations are as follows.

Note: The ON and OFF time ratio does not correspond with the percentage of microwave power, because approx. 2 seconds are needed for heating of the magnetron filament.

Note: During alternate Microwave/Convection operation, the convection heater is energized only if the cavity temperature drops below the set temperature.

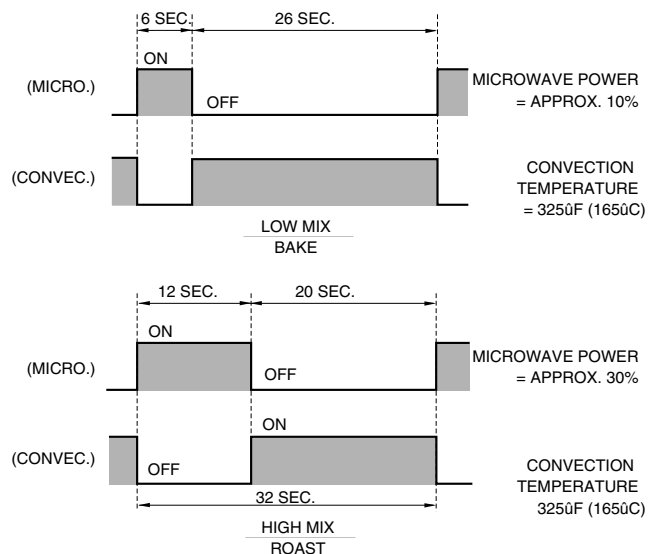

### SENSOR COOKING CONDITION

Using the SENSOR COOK, REHEAT or POPCORN function, the foods are cooked or defrosted without figuring time, power level or quantity. When the oven senses enough steam from the food, it relays the information to its microprocessor which will calculate the remaining cooking time and power level needed for best results.

When the food is cooked, water vapor is developed. The sensor "senses" the vapor and its resistance increases gradually. When the resistance reaches the value set according to the menu, supplementary cooking is started.

The time of supplementary cooking is determined by ex-

periment with each food category and inputted into the LSI. An example of how sensor works:



1. Potatoes at room temperature. Vapor is emitted very slowly.

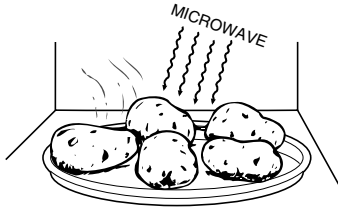

2. Heat potatoes. Moisture and humidity is emitted rapidly. You can smell the aroma as it cooks.

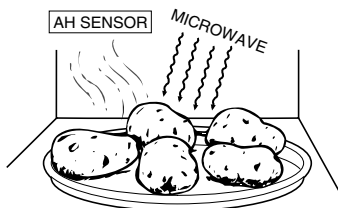

3. Sensor detects moisture and humidity and calculates cooking time and variable power.

#### Cooking Sequence.

1. Touch SENSOR COOK, REHEAT or POPCORN pad. When Sensor Cook is touched, to choose menu the number pad should be touched.

NOTE: The oven should not be operated on SENSOR COOK, REHEAT or POPCORN immediately after plugging in the unit. Wait five minutes before cooking on SENSOR COOK, REHEAT or POPCORN.

2. The coil of shut-off relays (RY1, RY4 and RY5) are energized, the oven lamp, turntable motor and cooling fan motor are turned on, but the power transformer is not turned on.
3. After about 32 seconds, the cook relay (RY2) is energized. The power transformer is turned on, microwave energy is produced and first stage is started. The 32 seconds is the cooling time required to remove any vapor from the oven cavity and sensor.

NOTE: During this first stage, do not open the door or touch STOP/CLEAR pad.

4. When the sensor detects the vapor emitted from the food, the display switches over to the remaining cooking time and the timer counts down to zero. At this time, the door may be opened to stir food, turn it or season, etc.
5. When the timer reaches zero, an audible signal sounds. The shut-off relay and cook relay are de-energized and the power transformer, oven lamp, etc. are turned off.
6. Opening the door or touching the STOP/CLEAR pad, the time of day will reappear on the display and the oven will revert to an OFF condition.

#### CONVEC BROIL, CONVEC ROAST, CONVEC BAKE

CONVEC BROIL, CONVEC ROAST and CONVEC BAKE will automatically compute the oven temperature, microwave power and cooking time for broiling, roasting and baking. Set

the desired program by touching one of the CONVEC BROIL, CONVEC ROAST or CONVEC BAKE pad, and number pad. Enter the weight by touching the Number pads. When the START pad is touched, the following operations occur:

1. The COOK indicator will light and the CONV or MIX indicator will light.
2. The cooking time will appear on the display and start counting down to zero. The cooking time is adjusted automatically according to the weight of the food.
3. The shut-off relays (RY1, RY4, RY5 and RY7) are energized, turning on the oven lamp, turntable motor, cooling fan motor and convection motor. The power supply voltage is applied to the heating element.
4. Now, the oven is in the convection cooking mode or Automatic Mix Cooking condition.
5. When the oven temperature has reached the programmed convection temperature, the oven goes into the programmed cooking mode.
6. At the end of the cooking cycle, the damper is returned to the open position and the oven will go to the off condition. The cooling fan will remain on until the oven has cooled.

#### TIMED DEFROST COOKING

The DEFROST key is a special function key to defrost meats and poultry faster and better. DEFROST automatically defrosts roast beef, etc.. When the DEFROST is selected and the food weight is entered by using the DEFROST pad, the oven will cook according to the special cooking sequence.

#### FIRE SENSING FEATURE (MICROWAVE MODE)

This model incorporates a sensing feature which will stop the oven's operation if there is a fire in the oven cavity during microwave cooking.

This is accomplished by the LSI repeatedly measuring the voltage across the temperature measurement circuit (thermistor) during its 32-seconds time base comparing the obtained voltage measurements. If the most recent voltage measured is 100mV greater than the previous voltage measured, the LSI judges it as a fire in the oven cavity and switches off the relays to the power transformer and fan motor. The LSI also stops counting down and closes the damper plate so that no fresh air will enter the oven cavity. Please refer to the following section for a more detailed description.

#### Operation

The following operation will start 4 minutes after the start pad is touched. Please refer to the timing diagrams below.

1. The thermistor operates within a 32-seconds time base and it is energized for three (3) seconds and off for 29 seconds. Two (2) seconds after the thermistor is energized, the voltage across the temperature measurement circuit is sampled by the LSI and twenty one (21) seconds after the thermistor is cut off the LSI turns on the convection motor for six (6) seconds.
2. The above procedure is repeated. If the difference between the first voltage measured (in step 1) and the voltage measured when the procedure is repeated (step 2) is greater than 100mV the LSI makes the judgment that there is a fire in the oven cavity and will switch off the relays to the power transformer and fan motor. The LSI also stops counting down and closes the damper door so that no fresh air will enter the oven cavity.
3. Once the fire sensor feature has shut the unit down, the programmed cooking cycle may be resumed by pressing

the "START" pad or the unit may be reset by pressing the "CLEAR" pad.

**IMPORTANT:**

**During sensor cooking operation, the fire sensing operation sequence will not begin until the AH sensor has detected vapors and initiated a sensor cooking cycle. This is because the operation of the convection fan would interfere with the AH sensor's vapor detection.**

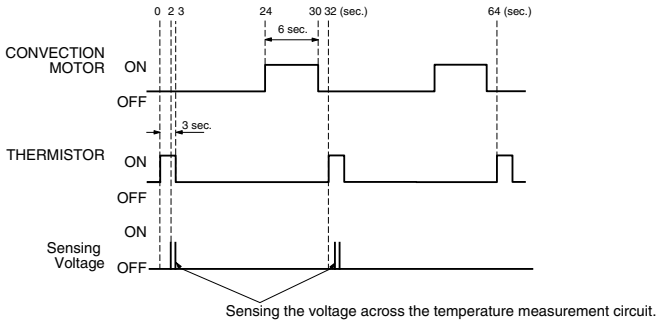

**3. RE-CIRCULATION (INSIDE VENTING)**

The air handling is same as VERTICAL VENTING except that the final air discharge is directed horizontally through the upper front of the oven into the kitchen. IN this case, the accessory charcoal filter lit RK-220 must be provided to filter the air before it leaves the oven.

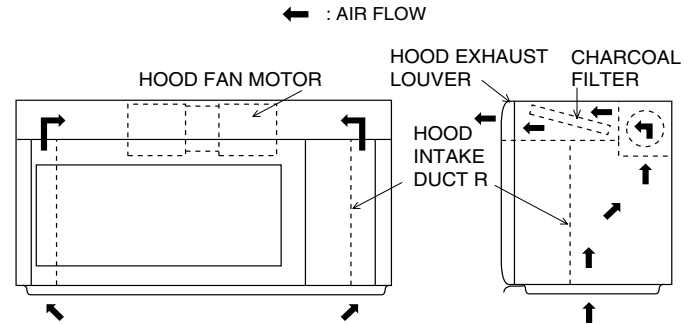

**VENTILATION METHODS HOT AIR EXHAUST**

**1. VERTICAL VENTING**

For this venting method, hot air rising from the conventional range below is drawn in by the hood fan motor through the grease filters at the right and left sides of the base cover, up through the right and left side intake ducts, then discharged vertically at rear center top of the oven, into the customer's vent system.

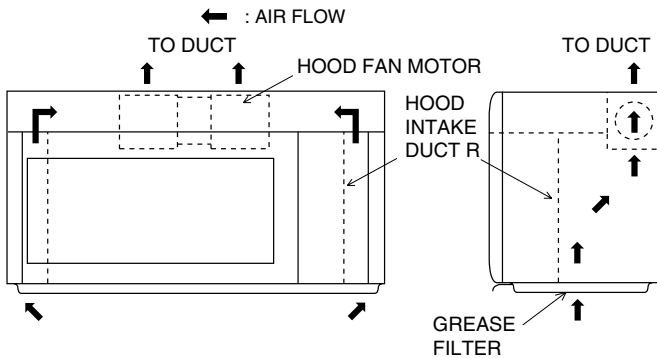

**2. HORIZONTAL VENTING**

The air handling is same as VERTICAL VENTING except that the final air discharge is directed horizontally out from the top rear of the oven into the customer's vent system.

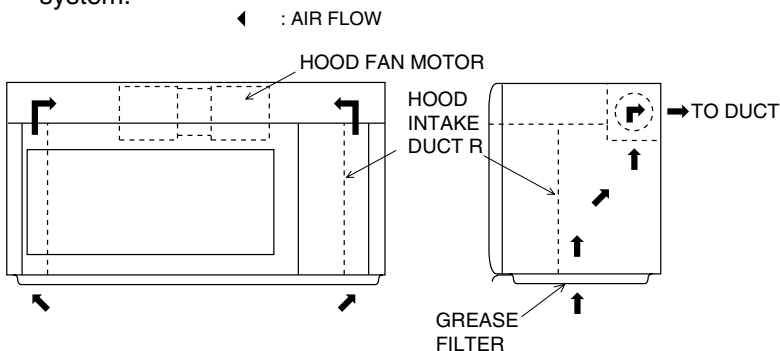

**SCHMATIC**

NOTE: CONDITION OF OVEN

1. DOOR CLOSED.
2. CLOCK APPEARS ON DISPLAY.

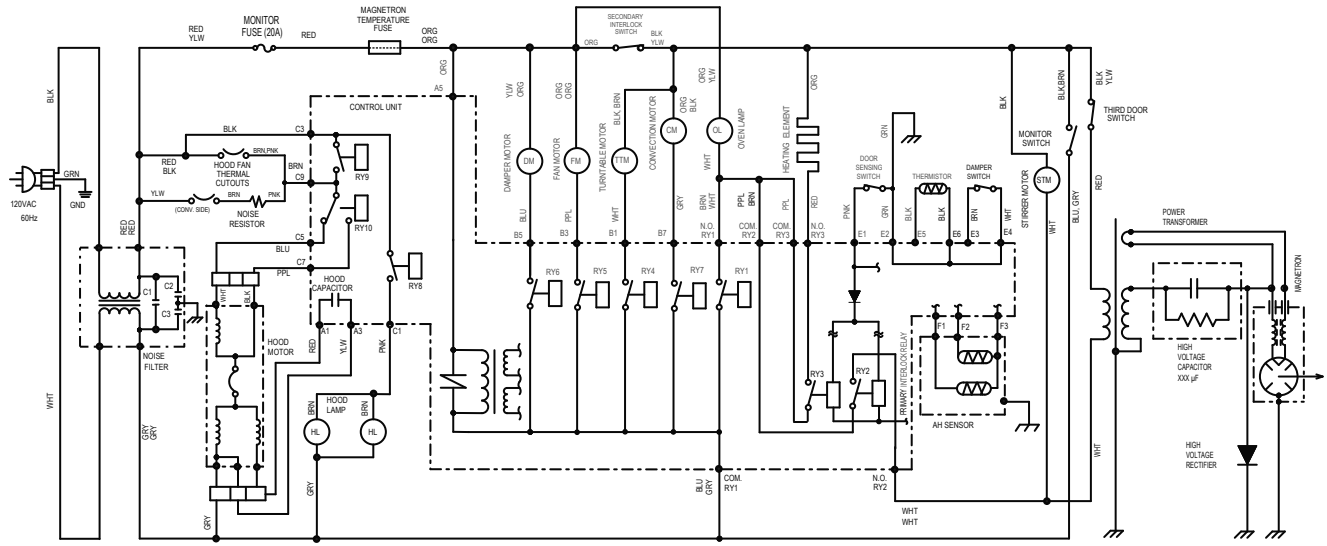

- NOTES:
1. Circuits / Wire colors subject to change without notice
  2. Terminal with projection or opposite blue mark on lamp socket must be connected to neutral wire.
  3. Only certain models use the absolute humidity sensor.
  4. Power transformer top (finish lead) terminal must be connected to the hot wire (RED)

**Figure O-1. Oven Schematic - Off Condition**

**SCHMATIC**

NOTE: CONDITION OF OVEN

1. DOOR CLOSED.
2. COOKING TIME PROGRAMMED.
3. START PAD TOUCHED.

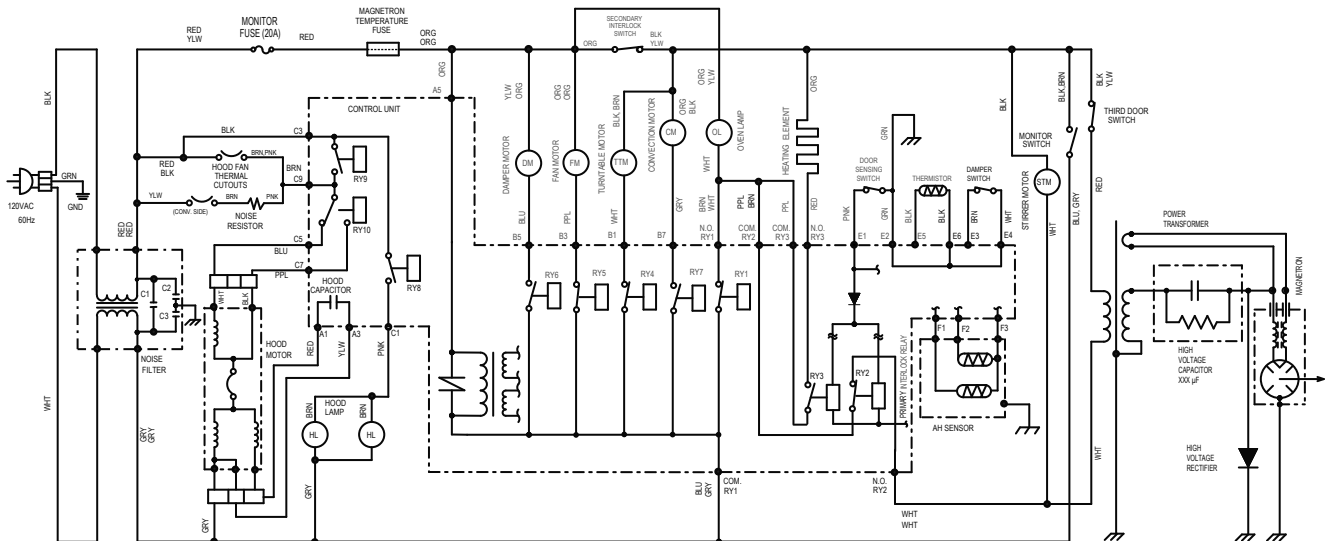

- NOTES:
1. Circuits / Wire colors subject to change without notice
  2. Terminal with projection or opposite blue mark on lamp socket must be connected to neutral wire.
  3. Only certain models use the absolute humidity sensor.
  4. Power transformer top (finish lead) terminal must be connected to the hot wire (RED)

**Figure O-2. Oven Schematic - Microwave Cooking Condition**

**SCHEMATIC**

NOTE: CONDITION OF OVEN

1. DOOR CLOSED.
2. CONVECTION PAD TOUCHED.
3. DESIRED TEMP. TOUCHED.
4. START PAD TOUCHED.

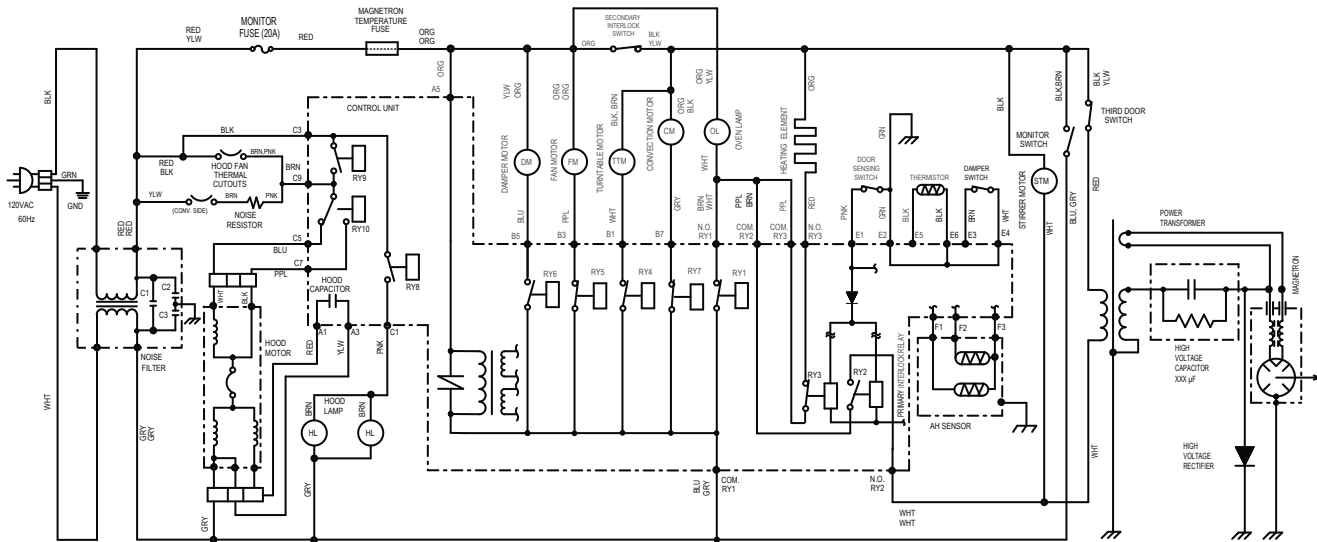

- NOTES:
1. Circuits / Wire colors subject to change without notice
  2. Terminal with projection or opposite blue mark on lamp socket must be connected to neutral wire.
  3. Only certain models use the absolute humidity sensor.
  4. Power transformer top (finish lead) terminal must be connected to the hot wire (RED)

**Figure O-3. Oven Schematic - Convection Cooking Condition (CONVEC, PREHEAT, BROIL, SLOW COOK)**

**SCHEMATIC**

NOTE: CONDITION OF OVEN

1. DOOR CLOSED.
2. MIX COOKING PAD TOUCHED.
3. DESIRED TEMP. TOUCHED.
4. COOKING TIME PROGRAMMED.
5. START PAD TOUCHED.

NOTE: RY2 and RY3 will alternately close during cook cycle

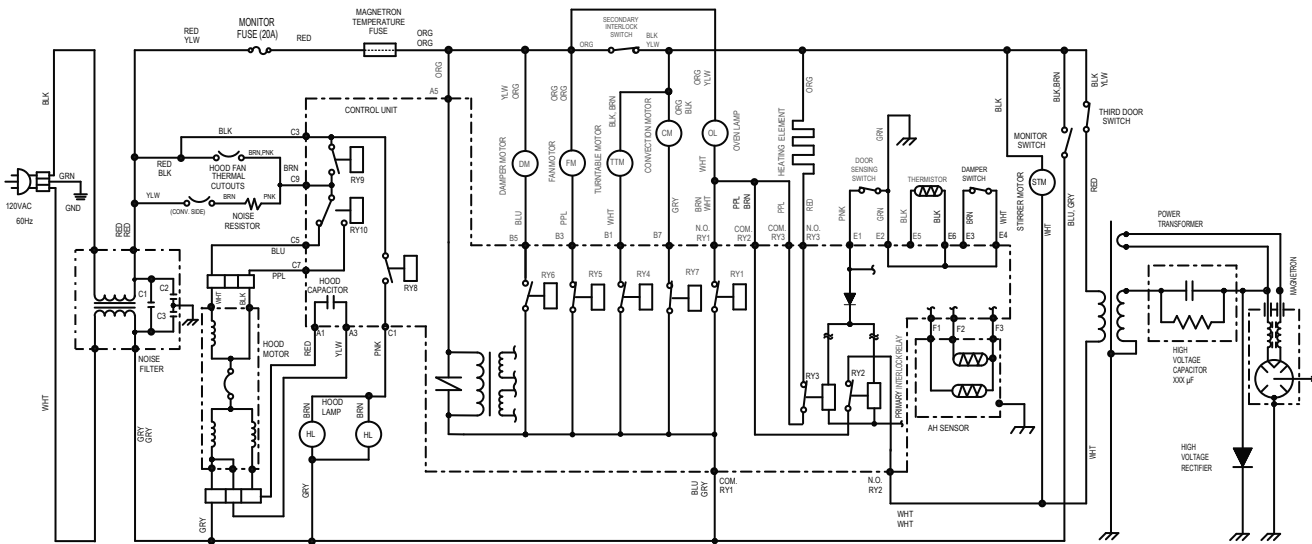

- NOTES:
1. Circuits / Wire colors subject to change without notice
  2. Terminal with projection or opposite blue mark on lamp socket must be connected to neutral wire.
  3. Only certain models use the absolute humidity sensor.
  4. Power transformer top (finish lead) terminal must be connected to the hot wire (RED)

**Figure O-4. Oven Schematic - Automatic Mix cooking Condition**



## DESCRIPTION AND FUNCTION OF COMPONENTS

### DOOR OPEN MECHANISM

The door is opened by pushing the open button on the control panel, refer to the Figure D-1.

When the open button is pushed, the open button pushes up the open lever, and then the open lever pushes up the latch head. The latch heads are moved upward and released from latch hook. Now the door will open.

Figure D-1. Door Open Mechanism

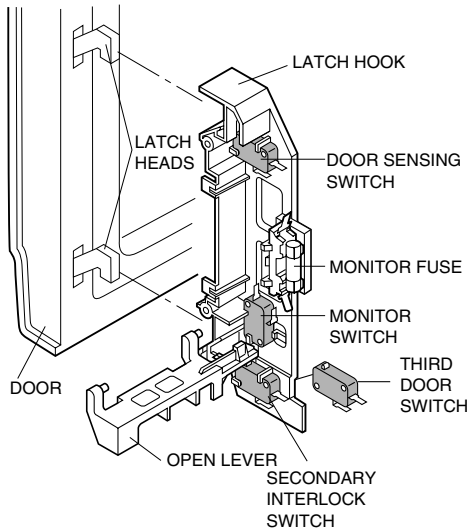

### SECONDARY SWITCH, THIRD DOOR SWITCH & DOOR SENSING SWITCH

The secondary switch and third switch mounted parallel to each other horizontally in the upper positions of the latch hook, the door sensing switch is mounted horizontally in the upper position of the latch hook. They are activated by the latch head on the door. When the door is opened, the switches interrupt the power to all high voltage components, except the oven lamp. A cook cycle cannot take place until the door is firmly closed thereby activating all interlock switches. The secondary interlock system consists of the door sensing switch and the primary interlock relay located on the control circuit board.

### MONITOR SWITCH

The monitor switch is activated (the contacts opened) by the latch head on the door while the door is closed. The switch is intended to render the oven inoperative, by means of blowing the monitor fuse, when the contacts of the primary switch and secondary switch fail to open when the door is opened.

#### Functions:

1. When the door is opened, the monitor switch contact close (to the ON condition) due to their being normally closed. At this time the secondary interlock relay, primary switch and secondary switch are in the OFF condition (contacts open) due to their being normally open contact switches.
2. As the door goes to a closed position, the monitor switch contacts are first opened and then the door sensing switch, primary switch and secondary switch contacts close. (On opening the door, each of these switches

operate inversely.)

3. If the door is opened, and the secondary interlock relay, primary switch and secondary switch contacts fail to open, the monitor fuse blows simultaneously with closing of the monitor switch contacts.

**CAUTION:** BEFORE REPLACING A BLOWN MONITOR FUSE, TEST THE SECONDARY INTERLOCK RELAY, SECONDARY SWITCH, DOOR SENSING SWITCH, MONITOR SWITCH AND PRIMARY SWITCH FOR PROPER OPERATION. (REFER TO CHAPTER "TEST PROCEDURE").

**NOTE:** MONITOR FUSE, PRIMARY SWITCH AND MONITOR SWITCH ARE REPLACED AS AN ASSEMBLY.

### TEMPERATURE FUSE (MG)

The temperature fuse located near the waveguide is designed to prevent damage to the magnetron if an over heated condition develops in the tube due to cooling fan failure, obstructed air guide, dirty or blocked air intake, etc. Under normal operation, the temperature fuse remains closed. However, the temperature fuse will open at 302°F (150°C) causing the oven to shut down.

### THERMAL CUT-OUT (HOOD)

This thermal cut-out located on the base plate right. It is designed to automatically turn on the hood fan motor whenever the hot air rising from the conventional range below causes the temperature at the thermal cut-out to rise to 140°F (60°C) or higher, thus removing this hot air from around microwave oven. When the temperature around the thermal cut-out drops to 113°F (45°C) or lower, the thermal cut-out shuts off the food fan motor.

### TURNTABLE MOTOR

The turntable motor rotates the turntable located on the bottom of the oven cavity, so that the foods on the turntable cook evenly during cooking. Turntable will turn in either direction. The turntable motor can be turned off by touching TURNTABLE ON/OFF pad.

### COOLING FAN MOTOR

The cooling fan motor drives a blade which draws external cool air. This cool air is directed through the air vanes surrounding the magnetron and cools the magnetron. This air is channelled through the oven cavity to remove steam and vapors given off from the heating foods. It is then exhausted through the exhausting air vents at the oven cavity.

### HOOD FAN MOTOR

The hood fan motor is a two-speed, single-phase, double pole induction type, requiring a hood fan capacitor. It is located outside the upper rear part of the oven cavity, is to remove, from around the oven, hot air rising from the conventional electric or gas range over which it is installed. This air is then expelled either vertically or horizontally through the customer supplied duct system, or discharged back into the kitchen.

## STIRRER MOTOR

The stirrer motor drives the stirrer fan to stir the microwave radiation from the waveguide.

## HOOD LAMP

The hood lamps are mounted at the hood lamp angle on the base cover. When the hood lamp button is pushed, the hood lamp relay (RY8) contacts close turning both hood lamps on.

## HEATING ELEMENT

The heating element is located at the left side of the oven cavity. It is intended to heat air driven by the convection fan. The heated air is kept in the oven and force-circulated and reheated by the heating element.

## CONVECTION COOKING SYSTEM

This oven is designed with a hot air heating system where food is not directly heated by the heating element, but is heated by forced circulation of the hot air produced by the heating element.

The air heated by the heating element is circulated through the convection passage provided on the outer casing of the oven cavity by means of the convection fan which is driven by the convection motor. It then enters the inside of the oven through the vent holes provided on the left side of the oven. Next, the hot air heats the food on the turntable and leaves the oven cavity through the vent in the center of the oven cavity left side wall.

Without leaving the oven, this hot air is reheated by the heating element, passes through the convection passage and enters the inside of the oven cavity again, in a continuing cycle.

In this way, the hot air circulates inside the oven cavity to raise its temperature and, at the same time, comes into contact with the food being cooked.

When the temperature inside the oven cavity reaches the selected temperature, the heating element is de-energized. When the temperature inside the oven cavity drops below the selected temperature, the heating element is energized again. In this way, the inside of the oven cavity is maintained at approximately the selected temperature.

When the convection time reaches 0, the heating element is de-energized and the convection fan stops operating and the oven shuts off.

## DAMPER OPEN-CLOSE MECHANISM

Usually, the damper is in the open position except during convection cooking. Damper position is set automatically by damper motor, damper switch and motor cam. These components are operated by a signal that judges if microwave cooking or convection cooking operation is selected by the control unit.

### Microwave Cooking:

Damper is in the open position, because a portion of cooling air is channeled through the cavity to remove steam and vapors given off from the heating foods.

It is then exhausted at the top of the oven cavity into a condensation compartment.

### Convection Cooking:

Damper is in the closed position, so that no hot air will be allowed to leak out the oven cavity.

## Damper Operation

1. When power supply cord is plugged in:
  - 1-1. When power supply cord is plugged in, a signal is sensed in the control unit, and operates shut-off relay (RY6).
  - 1-2. Contacts of shut-off relay (RY6) close, the damper motor is energized, opening the damper plate.
  - 1-3. When the damper is moved to the open position by the damper cam the damper switch is closed (ON position).
  - 1-4. The signal from damper switch is re-sensed in the control unit and shut-off relay (RY6) is turned off.
  - 1-5. The 120 volts A.C. to the damper motor is removed and the motor turns off.
2. When oven is microwave cooking:
 

Damper is in the open position.
3. When oven is convection cooking:
  - 3-1. Damper motor is energized by touching the convection, temperature, number and START pads.
  - 3-2. When damper is in the closed position (damper switch is OFF), its signal is sensed by the control unit, and shut-off relay (RY6) is de-energized.
  - 3-3. The damper is held in the closed position during the convection cooking operation.
  - 3-4. At the end of the convection cooking, shut-off relay (RY6) is energized, and the damper is returned to the open position.

**NOTE:** If the damper plate is not in the proper position, closed during convection or open during microwave, the control unit will stop oven operation after 1 minute.

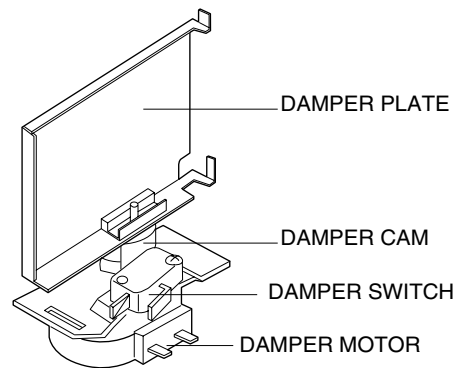

**Figure D-2. Damper Mechanism**

## TROUBLESHOOTING GUIDE

**Never touch any part in the circuit with your hand or an uninsulated tool while the power supply is connected.**

When troubleshooting the microwave oven, it is helpful to follow the Sequence of Operation in performing the checks. Many of the possible causes of trouble will require that a specific test be performed. These tests are given a procedure letter which will be found in the "Test Procedure "section.

**IMPORTANT:** If the oven becomes inoperative because of a blown monitor fuse, check the secondary switch, door sensing switch, secondary interlock relay(RY2), primary switch and monitor switch, before replacing the monitor fuse. If the monitor fuse is replaced, the monitor switch and primary switch must also be replaced. Use part FFS-BA018/KIT as an assembly.

**IMPORTANT:** Whenever troubleshooting is performed with the power supply cord disconnected. It may in, some cases, be necessary to connect the power supply cord after the outer case has been removed, in this event,

1. Disconnect the power supply cord, and then remove outer case.
2. Open the door and block it open.
3. Discharge high voltage capacitor.
4. Disconnect the leads to the primary of the power transformer.
5. Ensure that the leads remain isolated from other components and oven chassis by using insulation tape.
6. After that procedure, reconnect the power supply cord.

### **When the testing is completed**

1. Disconnect the power supply cord, and then remove outer case.
2. Open the door and block it open.
3. Discharge high voltage capacitor.
4. Reconnect the leads to the primary of the power transformer.
5. Reinstall the outer case (cabinet).
6. Reconnect the power supply cord after the outer case is installed.
7. Run the oven and check all functions.

# TROUBLESHOOTING GUIDE

When troubleshooting the microwave oven, it is helpful to follow the Sequence of Operation in performing the checks. Many of the possible causes of trouble will require that a specific test be performed. These tests are given a procedure letter which will be found in the "Test Procedure" section.

CK = Check / RE = Replace

	TEST PROCEDURE	A	B	C	D	E	F	G	H	I	J	K	L
CONDITION	PROBLEM	MAGNETRON	POWER TRANSFORMER	H.V. RECTIFIER	HIGH VOLTAGE CAPACITOR	PRIMARY OR DOOR SENSING SWITCH	PRIMARY INTERLOCK SYSTEM	MONITOR SWITCH	DAMPER SWITCH	MONITOR FUSE	TEMPERATURE FUSE (MG)	HOOD THERMAL CUT-OUT	THERMISTOR
OFF CONDITION	Home fuse blows when power cord is plugged into wall receptacle.												
	Monitor fuse blows when power cord is plugged into wall receptacle.												
	Display does not illuminate when power cord is first plugged into wall receptacle.									○	○		
	Display does not operate properly when STOP/CLEAR key is touched. (The time of day should appear on the display with beep sound during normal condition.)						○						
	Oven lamp does not light with door is opened.						○						
	Hood fan motor operates when power cord is first plugged into wall receptacle.						○						
	Temperature of oven base seems more than 140°F (60°C) because of operation of the range below. But hood fan motor does not turn on automatically. (Normally, food fan motor should be operating at low speed.)											○	○
IDLE CONDITION	Hood lights do not turn on with pushed Light button.												
	Hood fan motor does not rotate at all with pushed Vent button.												
	Speed of the hood fan motor does not change when the Vent button is touched for this function.												
COOKING CONDITION (COMMON)	Oven lamp does not light in cook cycle. (But it does light when door is opened.)												
	Fan motor does not operate. (Oven lamp and turntable motor operate.)												
	Turntable motor does not operate (Oven lamp lights and fan motor operate.)								○				
	Cooking cycle runs 1 minute then shuts down.												
MICROWAVE COOKING CONDITION	Oven does not go into cook cycle when START pad is touched					○	○						
	Oven seems to be operating but little or no heat is produced in oven load. (Food incompletely cooked or not cooked at all at end of cook cycle.)	○	○	○	○								
	Oven goes into a cook cycle but extremely uneven heating is produced in oven load (food).												
	Variable cooking does not operate properly except Cooking Power 10 (P-HI) mode.												
	Function of TIMED DEFROST does not operate properly.												
CONVECTION COOKING CONDITION	Stirrer motor does not operate. (Other parts operate.)												
	CONV indicator lights, but oven does not go into cook cycle when START pad is touched.					○							
	CONV indicator lights, but heating element does not heat.					○							○
	Temperature in the oven cavity is lower or higher than preset.												○
	Convection motor does not operate.												○
SENSOR COOKING CONDITION	Convection cycle runs 4 minutes and 15 seconds then shuts down.												○
	The oven stops and "ERROR" is displayed or does not end during Sensor Cooking condition. (Oven does not shut off after a cup of water is boiling by Sensor Cooking.)												
	Oven stops at 32 seconds after starting.												



---

**TEST PROCEDURES**

---

**PROCEDURE  
LETTER**
**COMPONENT TEST**

---

**A      POWER TRANSFORMER TEST**

1. Disconnect the power supply cord, and then remove outer case.
2. Open the door and block it open.
3. Discharge high voltage capacitor.
4. To test for an open filament, isolate the magnetron from the high voltage circuit. A continuity check across the magnetron filament leads should indicate less than 1 ohm.
5. To test for a shorted magnetron, connect the ohmmeter leads between the magnetron filament leads and chassis ground. This test should indicate an infinite resistance. If there is little or no resistance the magnetron is grounded and must be replaced.
6. Reconnect all leads removed from components during testing.
7. Reinstall the outer case (cabinet).
8. Reconnect the power supply cord after the outer case is installed.
9. Run the oven and check all functions.

**MICROWAVE OUTPUT POWER**

The following test procedure should be carried out with the microwave oven in a fully assembled condition (outer case fitted).

**HIGH VOLTAGES ARE PRESENT DURING THE COOK CYCLE, SO EXTREME CAUTION SHOULD BE OBSERVED.**

Power output of the magnetron can be measured by performing a water temperature rise test. This test should only be used if above tests do not indicate a faulty magnetron and there is no defect in the following components or wiring: silicon rectifier, high voltage capacitor and power transformer. This test will require a 16 ounce (453cc) measuring cup and an accurate mercury thermometer or thermocouple type temperature tester. For accurate results, the following procedure must be followed carefully:

1. Fill the measuring cup with 16 oz. (453cc) of tap water and measure the temperature of the water with a thermometer or thermocouple temperature tester. Stir the thermometer or thermocouple through the water until the temperature stabilizes. Record the temperature of the water.
2. Place the cup of water in the oven. Operate oven at POWER 10(HIGH) selecting more than 60 seconds cook time. Allow the water to heat for 60 seconds, measuring with a stop watch, second hand of a watch or the digital read-out countdown.
3. Remove the cup from the oven and again measure the temperature, making sure to stir the thermometer or thermocouple through the water until the maximum temperature is recorded.
4. Subtract the cold water temperature from the hot water temperature. The normal result should be 21 to 39°F(11.7 to 21.7°C) rise in temperature. If the water temperatures are accurately measured and tested for the required time period the test results will indicate if the magnetron tube has low power output (low rise in water temperature) which would extend cooking time or high power output (high rise in water temperature) which would reduce cooking time. Because cooking time can be adjusted to compensate for power output, the magnetron tube assembly should be replaced only if the water temperature rise test indicates a power output well beyond the normal limits. The test is only accurate if the power supply line voltage is 120 volts and the oven cavity is clean.

**B      HIGH VOLTAGE RECTIFIER TEST**

1. Disconnect the power supply cord, and then remove outer case.
2. Open the door and block it open.
3. Discharge high voltage capacitor.
4. Disconnect the primary input terminals and measure the resistance of the transformer with an ohmmeter. Check for continuity of the coils with an ohmmeter. On the R x 1 scale, the resistance of the primary coil should be less than 1 ohm and the resistance of the high voltage coil should be approximately 123 ohms; the resistance of the filament coil should be less than 1 ohm.
5. Reconnect all leads removed from components during testing.
6. Reinstall the outer case (cabinet).
7. Reconnect the power supply cord after the outer case is installed.
8. Run the oven and check all functions.

(HIGH VOLTAGES ARE PRESENT AT THE HIGH VOLTAGE TERMINAL, SO DO NOT ATTEMPT TO MEASURE THE FILAMENT AND HIGH VOLTAGE.)

---

**TEST PROCEDURES**

---

**PROCEDURE  
LETTER**
**COMPONENT TEST**

---

**C      MAGNETRON ASSEMBLY TEST**

1. Disconnect the power supply cord, and then remove outer case.
2. Open the door and block it open.
3. Discharge high voltage capacitor.
4. Isolate the rectifier from the circuit. Using the highest ohm scale of the meter, read the resistance across the terminals and observe, reverse the leads to the rectifier terminals and observe meter reading. If a short is indicated in both directions, or if an infinite resistance is read in both directions, the rectifier is probably defective and should be replaced.
5. Reconnect all leads removed from components during testing.
6. Reinstall the outer case (cabinet).
7. Reconnect the power supply cord after the outer case is installed.
8. Run the oven and check all functions.

**NOTE: Be sure to use an ohmmeter that will supply a forward bias voltage of more than 6.3 volts.**

---

**D      HIGH VOLTAGE CAPACITOR TEST**

1. Disconnect the power supply cord, and then remove outer case.
  2. Open the door and block it open.
  3. Discharge high voltage capacitor.
  4. If the capacitor is open, no high voltage will be available to the magnetron. Disconnect input leads and check for short or open between the terminals using an ohmmeter. Checking with a high ohm scale, if the high voltage capacitor is normal, the meter will indicate continuity for a short time and should indicate an open circuit once the capacitor is charged. If the above is not the case, check the capacitor with an ohmmeter to see if it is shorted between either of the terminals and case. If it is shorted, replace the capacitor.
  5. Reconnect all leads removed from components during testing.
  6. Reinstall the outer case (cabinet).
  7. Reconnect the power supply cord after the outer case is installed.
  8. Run the oven and check all functions.
- 

**E      SECONDARY INTERLOCK SWITCH AND THIRD DOOR SWITCH TEST**

1. Disconnect the power supply cord, and then remove outer case.
2. Open the door and block it open.
3. Discharge high voltage capacitor.
4. Isolate the switch and connect the ohmmeter to the common (COM.) and normally open (NO) terminal of the switch. The meter should indicate an open circuit with the door open and a closed circuit with the door closed. If improper operation is indicated, replace the secondary interlock switch.
5. Reconnect all leads removed from components during testing.
6. Reinstall the outer case (cabinet).
7. Reconnect the power supply cord after the outer case is installed.
8. Run the oven and check all functions.

**SECONDARY INTERLOCK SYSTEM TEST**
**DOOR SENSING SWITCH**

1. Disconnect the power supply cord, and then remove outer case.
2. Open the door and block it open.
3. Discharge high voltage capacitor.
4. Isolate the switch and connect the ohmmeter to the common (COM.) and normally open (NO) terminal of the switch. The meter should indicate an open circuit with the door open and a closed circuit with the door closed. If improper operation is indicated, replace the door sensing switch.
5. Reconnect all leads removed from components during testing.
6. Reinstall the outer case (cabinet).
7. Reconnect the power supply cord after the outer case is installed.
8. Run the oven and check all functions.

**NOTE: If the door sensing switch contacts fail in the open position and the door is closed, the cooling fan, turntable and oven light will be activated by RY1.**

## TEST PROCEDURES

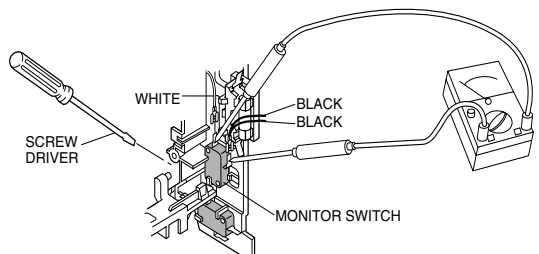
PROCEDURE LETTER	COMPONENT TEST
<b>F</b>	<p><b><u>PRIMARY INTERLOCK RELAY (RY2)</u></b></p> <ol style="list-style-type: none"> <li>1. Disconnect the power supply cord, and then remove outer case.</li> <li>2. Open the door and block it open.</li> <li>3. Discharge high voltage capacitor.</li> <li>4. Disconnect two (2) wire leads from the male tab terminals of the Primary Interlock Relay. Check the state of the relay contacts using a ohmmeter. The relay contacts should be open. If the relay contacts are closed, replace the circuit board entirely or the relay itself.</li> <li>5. Reconnect all leads removed from components during testing.</li> <li>6. Reinstall the outer case (cabinet).</li> <li>7. Reconnect the power supply cord after the outer case is installed.</li> <li>8. Run the oven and check all functions.</li> </ol>
<b>G</b>	<p><b><u>MONITOR SWITCH TEST</u></b></p> <ol style="list-style-type: none"> <li>1. Disconnect the power supply cord, and then remove outer case.</li> <li>2. Open the door and block it open.</li> <li>3. Discharge high voltage capacitor.</li> <li>4. Before performing this test, make sure that the primary interlock switch and the secondary interlock relay are operating properly, according to the above Switch Test Procedure. Disconnect the wire lead from the monitor switch (NC) terminal. Check the monitor switch operation by using the ohmmeter as follows. When the door is open, the meter should indicate a closed circuit. When the monitor switch actuator is pushed by a screw driver through the lower latch hole on the front plate of the oven cavity with the door opened (in this condition the plunger of the monitor switch is pushed in), the meter should indicate an open circuit. If improper operation is indicated, the switch may be defective. After testing the monitor switch, reconnect the wire lead to the monitor switch (NC) terminal and check the continuity of the monitor circuit.</li> <li>5. Reconnect all leads removed from components during testing.</li> <li>6. Reinstall the outer case (cabinet).</li> <li>7. Reconnect the power supply cord after the outer case is installed.</li> <li>8. Run the oven and check all functions.</li> </ol> <div style="text-align: right; margin-top: 20px;">  </div>
<b>H</b>	<p><b><u>DAMPER SWITCH TEST</u></b></p> <ol style="list-style-type: none"> <li>1. Disconnect the power supply cord, and then remove outer case.</li> <li>2. Open the door and block it open.</li> <li>3. Discharge high voltage capacitor</li> <li>4. Disconnect the wire leads from the switch terminals and connect ohmmeter leads to the common (COM.) and normally open (N.O.) terminals of the switch.</li> <li>5. When switch actuator is pushed by the damper cam, the meter should be indicated a closed circuit.</li> <li>6. When power cord is plugged into the wall receptacle, the damper motor operates and damper cam will start to rotate. When the switch actuator is released, the meter should be indicated an open circuit. If improper operation is indicated, replace the damper switch.</li> <li>7. Reconnect all leads removed from components during testing.</li> <li>8. Reinstall the outer case (cabinet).</li> <li>9. Reconnect the power supply cord after the outer case is installed.</li> <li>10. Run the oven and check all functions.</li> </ol>



---

**TEST PROCEDURES**

---

**PROCEDURE  
LETTER**
**COMPONENT TEST**

---

**I      BLOWN MONITOR FUSE**

1. Disconnect the power supply cord, and then remove outer case.
2. Open the door and block it open.
3. Discharge high voltage capacitor.
4. If the monitor fuse is blown when the door is opened, check the primary interlock relay, secondary interlock switch and monitor switch according to the "TEST PROCEDURE" for those switches before replacing the blown monitor fuse.

**CAUTION: BEFORE REPLACING A BLOWN MONITOR FUSE, TEST THE PRIMARY INTERLOCK RELAY, SECONDARY INTERLOCK SWITCH, DOOR SENSING SWITCH AND MONITOR SWITCH FOR PROPER OPERATION.**

If the monitor fuse is blown by improper switch operation, the monitor fuse and monitor switch must be replaced with "monitor fuse and monitor switch assembly" part number FFS-BA018/Kit, even if the monitor switch operates normally. The monitor fuse and monitor switch assembly is comprised of a 20 ampere fuse and switch.

5. Reconnect all leads removed from components during testing.
  6. Re-install the outer case (cabinet).
  7. Reconnect the power supply cord after the outer case is installed.
  8. Run the oven and check all functions.
- 

**J      TEMPERATURE FUSE TEST**
**MAGNETRON TEMPERATURE FUSE**

1. Disconnect the power supply cord, and then remove outer case.
2. Open the door and block it open.
3. Discharge high voltage capacitor.
4. A continuity check across the temperature fuse terminals should indicate a closed circuit. If the temperature of the magnetron reaches approximately 302°F(150°C), the temperature fuse opens. An open temperature fuse indicates overheating of the magnetron. Check for restricted air flow to the magnetron, especially the cooling fan air guide.
5. Reconnect all leads removed from components during testing.
6. Re-install the outer case (cabinet).
7. Reconnect the power supply cord after the outer case is installed.
8. Run the oven and check all functions.

**CAUTION: IF THE TEMPERATURE FUSE INDICATES AN OPEN CIRCUIT AT ROOM TEMPERATURE, REPLACE THE TEMPERATURE FUSE.**

---

**K      HOOD THERMAL CUT-OUT TEST**

1. Disconnect the power supply cord, and then remove outer case.
  2. Open the door and block it open.
  3. Discharge high voltage capacitor.
  4. A continuity check across the thermal cut-out terminals should indicate an open circuit unless the temperature of the thermal cut-out reaches approximately 140°F(60°C) or more. At that temperature, the contacts will close. The thermal cut-out opens automatically at approximately 113°F(45°C).
  5. Reconnect all leads removed from components during testing.
  6. Re-install the outer case (cabinet).
  7. Reconnect the power supply cord after the outer case is installed.
  8. Run the oven and check all functions.
- 

**L      THERMISTOR TEST**

Disconnect connector-E from the control unit. Measure the resistance of the thermistor with an ohmmeter. Connect the ohmmeter leads to Pin No's E-3 and E-4.

Room Temperature	Resistance
68F°(20°C) - 86°F(30°C)	Approx. 360 k ohm - 152 k ohm

If the meter does not indicate above resistance, replace the thermistor

## TEST PROCEDURES

PROCEDURE  
LETTER

## COMPONENT TEST

**M HOOD FAN MOTOR TEST**

1. Disconnect the power supply cord, and then remove outer case.
2. Open the door and block it open.
3. Discharge high voltage capacitor.
4. If the motor does not turn, touch the Vent button once (set hood fan motor power "HIGH") and check voltage between pins "1" and "2" (Blue and Black wires) of the 6 pin connector. If 120 Volts appear and the hood capacitor is good, replace the hood fan assembly. If 120 Volts does not appear, check the motor circuit. The resistance values of motor terminals are as follows:

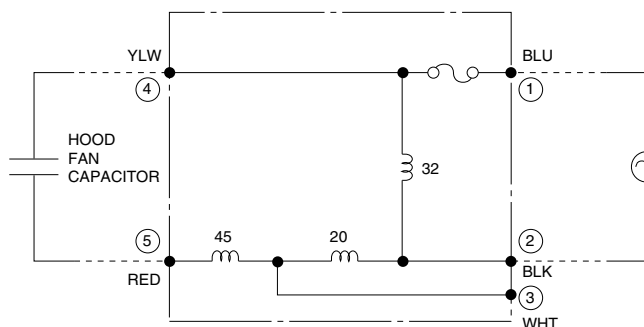
Resistance between:

BLU (1)	AND	YLW (4)	= 0 ohm (Shorted)
BLK (2)	AND	YLW (4)	= 32 ohm
BLU (1)	AND	BLK (2)	= 32 ohm
BLK (2)	AND	WHT (3)	= 20 ohm
WHT (3)	AND	RED (5)	= 45 ohm

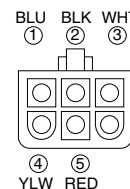
6-PIN CONNECTOR  
OF HOOD FAN MOTOR

5. Reconnect all leads removed from components during testing.
6. Re-install the outer case (cabinet).
7. Reconnect the power supply cord after the outer case is installed.
8. Run the oven and check all functions.

**N DAMPER MOTOR TEST**

1. Disconnect the power supply cord, and then remove outer case.
2. Open the door and block it open.
3. Discharge high voltage capacitor.
4. When the power cord is plugged into the wall receptacle and 120 volts A.C. is supplied to the damper motor, the motor operates until the damper is opened and the damper switch closes. Then the damper motor stops operation.
5. If the damper motor does not operate, check for A.C. voltage with a voltmeter at the motor.
6. Disconnect the power cord from the wall receptacle.
7. Disconnect the wire leads of motor and connect the meter leads to the wire leads of main wire harness.
8. Re-connect the power cord into the wall receptacle.  
If 120 volts A.C. is indicated at the wire leads, replace the motor and if 120 volts A.C. is not indicated, check the wire harness and control unit.
9. Run the oven and check all functions.

**O HEATING ELEMENT TEST**

1. Disconnect the power supply cord, and then remove outer case.
2. Open the door and block it open.
3. Discharge high voltage capacitor.
4. Make sure the heating element is fully cooled and test as follows;
  - a. Disconnect wire leads and measure the resistance with an ohmmeter. On the R x 1 scale, the resistance between the heating element terminals should be approximately 10Ω.
  - b. Disconnect wire leads and measure the insulation resistance with 500V - 100M ohm insulation resistance meter. The insulation resistance between heating element terminal and cavity should be more than 0.5MΩ.
5. Reconnect all leads removed from components during testing.
6. Re-install the outer case (cabinet).
7. Reconnect the power supply cord after the outer case is installed.
8. Run the oven and check all functions.

---

**TEST PROCEDURES**

---

**PROCEDURE  
LETTER****COMPONENT TEST****P****CHECKING TEMPERATURE IN THE CONVECTION MODE**

1. Disconnect the power supply cord, and then remove outer case.
2. Open the door and block it open.
3. Discharge high voltage capacitor.
4. It is difficult to measure the exact temperature in the convection oven. An accurate thermocouple type temperature tester must be used. A low priced bi-metal type thermometer is not reliable or accurate. The temperature should be checked with outer case cabinet installed, approx. 5 minutes after preheat temperature is reached (audible signal sounds four times). The temperature experienced may be approx. 30°F more or less than indicated on the display, however, in most cases the food cooking results will be satisfactory. Difference in power supply voltage will also affect the oven temperature.
5. Reconnect all leads removed from components during testing.
6. Re-install the outer case (cabinet).
7. Reconnect the power supply cord after the outer case is installed.
8. Run the oven and check all functions.

**Q****TOUCH CONTROL PANEL ASSEMBLY TEST**

The touch control panel consists of circuits including semiconductors such as LSI, ICs, etc. Therefore, unlike conventional microwave ovens, proper maintenance cannot be performed with only a voltmeter and ohmmeter.

In this service manual, the touch control panel assembly is divided into two units, Control Unit, Key Unit, Power Unit, and troubleshooting by unit replacement is described according to the symptoms indicated.

**Before testing,**

- 1) Disconnect the power supply cord, and then remove outer case. Refer to procedure of "HOOD EXHAUST LOUVER REMOVAL", "REMOVAL OF OVEN FROM WALL" and "OUTER CASE REMOVAL".
- 2) Open the door and block it open.
- 3) Discharge high voltage capacitor.
- 4) Disconnect the leads to the primary of the power transformer.
- 5) Ensure that these leads remain isolated from other components and oven chassis by using insulation tape.
- 6) After that procedure, re-connect the power supply cord.

## 1. Key Unit.

**NOTE ;**

- 1) Disconnect the power supply cord, and then remove outer case.
- 2) Open the door and block it open.
- 3) Discharge high voltage capacitor.
- 4) Check key unit ribbon connection before replacement.
- 5) Reconnect all leads removed from components during testing.
- 6) Re-install the outer case (cabinet).
- 7) Reconnect the power supply cord after the outer case is installed.
- 8) Run the oven and check all functions.

The following symptoms indicate a defective key unit.

- a) When touching the pads, a certain pad produces no signal at all.
- b) When touching a number pad, two figures or more are displayed.
- c) When touching the pads, sometimes a pad produces no signal.

If the key unit is defective.

- 1) Disconnect the power supply cord, and then remove outer case.
- 2) Open the door and block it open.
- 3) Discharge high voltage capacitor.
- 4) Replace the key unit.
- 5) Reconnect all leads removed from components during testing.
- 6) Re-install the outer case (cabinet).
- 7) Reconnect the power supply cord after the outer case is installed.
- 8) Run the oven and check all functions.

## TEST PROCEDURES

### PROCEDURE LETTER

### COMPONENT TEST

#### Q TOUCH CONTROL PANEL ASSEMBLY TEST

##### 2. Control Unit.

The following symptoms indicate a defective control unit. Before replacing the control unit, perform the Key unit test (Procedure R) to determine if control unit is faulty.

##### 2-1 In connection with pads.

- a) When touching the pads, a certain group of pads do not produce a signal.
- b) When touching the pads, no pads produce a signal.

##### 2-2 In connection with indicators

- a) At a certain digit, all or some segments do not light up.
- b) At a certain digit, brightness is low.
- c) Only one indicator does not light.
- d) The corresponding segments of all digits do not light up; or they continue to light up.
- e) Wrong figure appears.
- f) A certain group of indicators do not light up.
- g) The figure of all digits flicker.

##### 2-3 Other possible problems caused by defective control unit.

- a) Buzzer does not sound or continues to sound.
- b) Clock does not operate properly.
- c) Cooking is not possible.

When testing is completed,

- 1) Disconnect the power supply cord, and then remove outer case.
- 2) Open the door and block it open.
- 3) Discharge high voltage capacitor.
- 4) Reconnect all leads removed from components during testing.
- 5) Re-install the outer case (cabinet).
- 6) Reconnect the power supply cord after the outer case is installed.
- 7) Run the oven and check all functions.

#### R KEY UNIT TEST

1. Disconnect the power supply cord, and then remove outer case.
2. Open the door and block it open.
3. Discharge high voltage capacitor.
4. If the display fails to clear when the STOP/CLEAR pad is depressed, first verify the flat ribbon is making good contact, verify that the door sensing switch (stop switch) operates properly; that is the contacts are closed when the door is closed and open when the door is open. If the door sensing (stop switch) is good, disconnect the flat ribbon that connects the key unit to the control unit and make sure the door sensing switch is closed (either close the door or short the stop switch connector). Use the key unit matrix indicated on the control panel schematic and place a jumper wire between the pins that correspond to the STOP/CLEAR pad making momentary contact. If the control unit responds by clearing with a beep, the key unit is faulty and must be replaced. If the control unit does not respond, it is faulty and must be replaced. If a specific pad does not respond, the above method may be used ( after clearing the control unit) to determine if the control unit or key pad is at fault.
5. Reconnect all leads removed from components during testing.
6. Re-install the outer case (cabinet).
7. Reconnect the power supply cord after the outer case is installed.
8. Run the oven and check all functions.

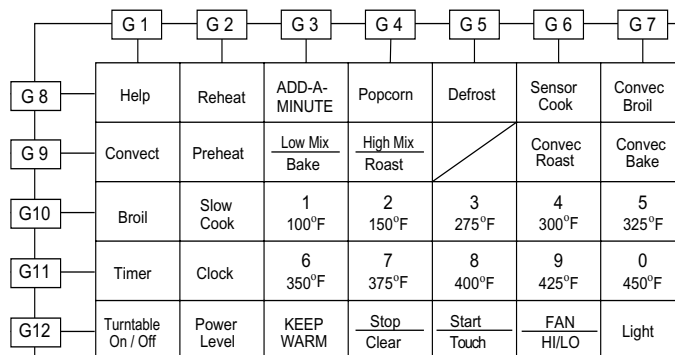

---

**TEST PROCEDURES**

---

**PROCEDURE  
LETTER****COMPONENT TEST****S****RELAY TEST**

1. Disconnect the power supply cord, and then remove outer case.
2. Open the door and block it open.
3. Discharge high voltage capacitor.
4. Disconnect the leads to the primary of the power transformer.
5. Ensure that these leads remain isolated from other components and oven chassis by using insulation tape.
6. After that procedure, re-connect the power supply cord.
7. Remove the outer case and check voltage between Pin No. 5 of the 3-pin connector (A) and the common terminal of the relay RY1 on the control unit with an A.C. voltmeter. The meter should indicate 120 volts, if not check oven circuit.

**Relay Test**

These relays are operated by D.C. voltage.

Check voltage at the relay coil with a D.C. voltmeter during the microwave cooking operation.

DC. voltage indicated.....Defective relay.

DC. voltage not indicated.....Check diode which is connected to the relay coil. If diode is good, control unit is defective.

RELAY SYMBOL	OPERATIONAL VOLTAGE	CONNECTED COMPONENTS
RY1	Approx. 24.0V D.C.	Oven lamp
RY2	Approx. 24.0V D.C.	Power transformer / Stirrer motor
RY3	Approx. 24.0V D.C.	Heating element
RY4	Approx. 24.0V D.C.	Turntable motor
RY5	Approx. 24.0V D.C.	Fan motor
RY6	Approx. 24.0V D.C.	Damper motor
RY7	Approx. 24.0V D.C.	Convection motor
RY8	Approx. 24.0V D.C.	Hood lamp
RY9	Approx. 24.0V D.C.	Hood motor
RY10	Approx. 24.0V D.C.	Hood motor (HIGH / LOW selection)

8. Disconnect the power supply cord, and then remove outer case.
9. Open the door and block it open.
10. Discharge high voltage capacitor.
11. Reconnect all leads removed from components during testing.
12. Re-install the outer case (cabinet).
13. Reconnect the power supply cord after the outer case is installed.
14. Run the oven and check all functions.

**T****TIMED DEFROST TEST**

1. Place one cup of water in the center of the turntable tray in the oven cavity.
2. Close the door, touch the " DEFROST " pad four times.
3. Touch the number 5 pad.
4. Touch " START " pad.
5. The oven will operate as follows.

MENU	WEIGHT (LBS)	1ST STAGE		2ND STAGE		3RD STAGE	
		LEVEL	TIME	LEVEL	TIME	LEVEL	TIME
CHICKEN PIECES	0.5	70%	28sec.	50%	5sec.	30%	1min.28sec.

6. If improper operation is indicated, the control unit is probably defective and should be checked.

## TEST PROCEDURES

### PROCEDURE LETTER

### COMPONENT TEST

U

#### **PROCEDURES TO BE TAKEN WHEN THE FOIL PATTERN ON THE PRINTED WIRING BOARD PWB IS OPEN**

To protect the electronic circuits, this model is provided with a fine foil pattern added to the primary on the PWB, this foil pattern acts as a fuse.

1. Disconnect the power supply cord, and then remove outer case.
2. Open the door and block it open.
3. Discharge high voltage capacitor.
4. If the foil pattern is open, follow the troubleshooting guide given below for repair.

Problem: POWER ON, indicator does not light up.

STEPS	OCCURRENCE	CAUSE OR CORRECTION
1	The rated voltage is not applied between Pin No. 5 of the 3-Pin connector (A) and the terminal of the relay RY1.	Check supply voltage and oven main unit.
2	The rated voltage is applied to primary side power transformer.	Power transformer or secondary circuit defective. Check and repair.
3	Only pattern at "a" is broken.	*Insert jumper wire (J1) and solder.
4	Pattern at "a" and "b" are broken.	*Insert the coil RCILF2003YAZZ between "c" and "d".

NOTE:\* At the time of making these repairs, make a visual inspection of the varistor. Check for burned damage and examine the transformer with an ohm-meter for the presence of a layer short-circuit (check Primary coil resistance which is approximately 195 ohm)

NOTE:\* At the time of making these repairs, make a visual inspection of the varistor. Check for burned damage and examine the transformer with an ohm-meter for the presence of a layer short-circuit (check Primary coil resistance which is approximately 195 ohm  $\pm$  15%). If any abnormal condition is detected, replace the defective parts.

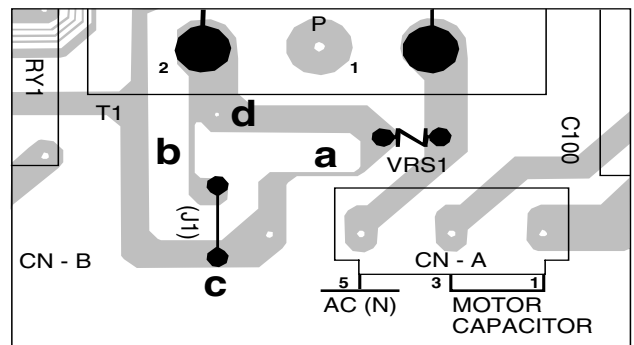

V

#### **AH SENSOR TEST**

##### **Checking the initial sensor cooking condition**

**Warning:** The oven should be fully assembled before following procedure.

- (1) The oven should be plugged in at least five minutes before sensor cooking.
- (2) Room temperature should not exceed 95°F (35°C).
- (3) The unit should not be installed in any area where heat and steam are generated. The unit should not be installed, for example, next to a conventional surface unit. Refer to the "INSTALLATION Instructions".
- (4) Exhaust vents are provided on the back of the unit for proper cooling and air flow in the cavity. To permit adequate ventilation, be sure to install so as not to block these vents. There should be some space for air circulation.
- (5) Be sure the exterior of the cooking container and the interior of the oven are dry. Wipe off any moisture with a dry cloth or paper towel.
- (6) The Sensor works with food at normal storage temperature. For example, chicken pieces would be at refrigerator temperature and canned soup at room temperature.
- (7) Avoid using aerosol sprays or cleaning solvents near the oven while using Sensor settings. The sensor will detect the vapor given off by the spray and turn off before food is properly cooked.
- (8) If the sensor has not detected the vapor of the food, ERROR will appear and the oven will shut off.

## TEST PROCEDURES

### PROCEDURE LETTER

### COMPONENT TEST

#### Water load cooking test

Make sure the oven has been plugged in at least five minutes before checking sensor cook operation. The cabinet should be installed and screws tightened.

- (1) Fill approximately 200 milliliters (7.2 oz) of tap water in a 1000 milliliter measuring cup.
- (2) Place the container on the center of tray in the oven cavity.
- (3) Close the door.
- (4) Touch SENSOR COOK pad. And touch the number pad 1. And touch the start pad. The oven will operate for the first 32 seconds, without generating microwave energy.

NOTE: ERROR will appear if the door is opened or STOP/CLEAR pad is touched during first stage of sensor cooking.

- (5) After approximately 32 seconds, microwave energy is produced, oven should turn off after water is boiling (bubbling).

If the oven does not turn off, replace the AH sensor or check the control unit, refer to explanation below.

#### TESTING METHOD FOR AH SENSOR AND/OR CONTROL UNIT

To determine if the sensor is defective, the simplest method is to replace it with a new replacement sensor.

- (1) Disconnect oven from power supply and remove outer case.
- (2) Open the door and block it open.
- (3) Discharge the high voltage capacitor.
- (4) Remove the AH sensor.
- (5) Install the new AH sensor.
- (6) Reconnect all leads removed from the components during replacing.
- (7) Re-install the outer case.
- (8) Reconnect the oven to the power supply and check the sensor cook operation proceed as follows:
  - 9-1. Fill approximately 200 milliliters (7.2 oz) of tap water in a 1000 milliliter measuring cup.
  - 9-2. Place the container on the center of tray in the oven cavity.
  - 9-3. Close the door.
  - 9-4. Touch SENSOR COOK pad. And touch the number pad 1. And touch the start pad.
  - 9-5. The oven will turn off automatically after the water is boiling (bubbling).

If new sensor does not operate properly, the problem is with the control unit.

#### CHECKING CONTROL UNIT

- (1) Disconnect oven from power supply and remove outer case.
- (2) Open the door and block it open.
- (3) Discharge the high voltage capacitor.
- (4) Disconnect the wire leads from the cook relay.
- (5) Disconnect the sensor connector that is mounted to lower portion of control panel.
- (6) Then connect the dummy resistor circuit (see fig.) to the sensor connector of control panel.
- (7) Reconnect the oven to the power supply and check the sensor cook operation proceed as follows:
  - 7-1. Touch SENSOR COOK pad. And touch the number pad 1. And touch the start pad.
  - 7-2. The control panel is in the sensor cooking operation.
  - 7-3. After approximately 32 seconds, push plunger of select switch. This condition is same as judgement by AH sensor.
  - 7-4. After approximately 3 seconds, cooking operation turns off, an audible signal will sound, and the display will then revert to the time of day.

If the above is not the case, the control unit is probably defective.

If the above is proper, the AH sensor is probably defective.

R1,R2 : 22 ohm  $\pm$  1% 1/2W  
 R3 : 10k ohm  $\pm$  5% 1/4W  
 R4 : 1M ohm  $\pm$  5% 1/4W

#### Sensor Dummy Resistor Circuit

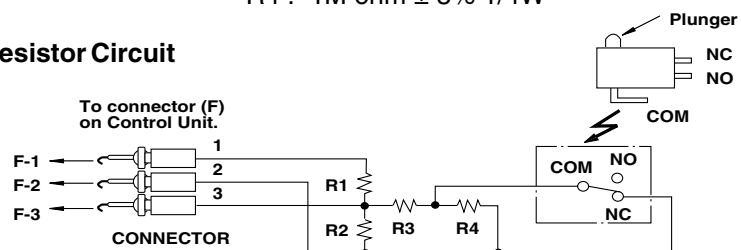

## TEST PROCEDURES

**PROCEDURE  
LETTER**

**COMPONENT TEST**

**W      NOISE FILTER TEST**

1. Disconnect the power supply cord, and then remove outer case.
2. Open the door and block it open.
3. Discharge high voltage capacitor.
4. Disconnect the leads to the primary of the power transformer.
5. Using an ohm-meter, check between the terminals as described in the following table:

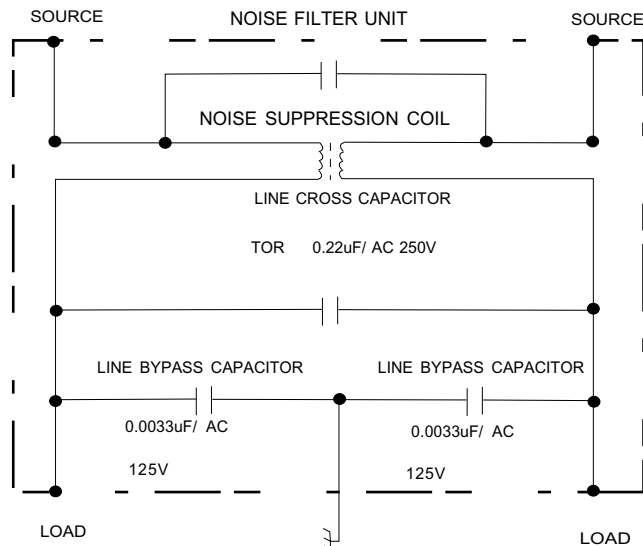

MEASURING POINT	INDICATION OF OHM-METER
Between N and H	Open Circuit
Between terminal N and GRY	Short Circuit
Between terminal H and RED	Short Circuit

If incorrect readings are obtained, replace the noise filter.

6. Reconnect all leads removed from components during testing.
7. Re-install the outer case (cabinet).
8. Reconnect the power supply cord after the outer case is installed.
9. Run the oven and check all functions.



## ABSOLUTE HUMIDITY SENSOR CIRCUIT

### (1) Structure of Absolute Humidity Sensor

The absolute humidity sensor includes two thermistors as shown in the illustration. One thermistor is housed in the closed glass tube filled with dry air while another in the open glass tube. Each sensor is provided with the protective cover made of metal with holes to be protected from the external airflow.

ventilation opening for sensing

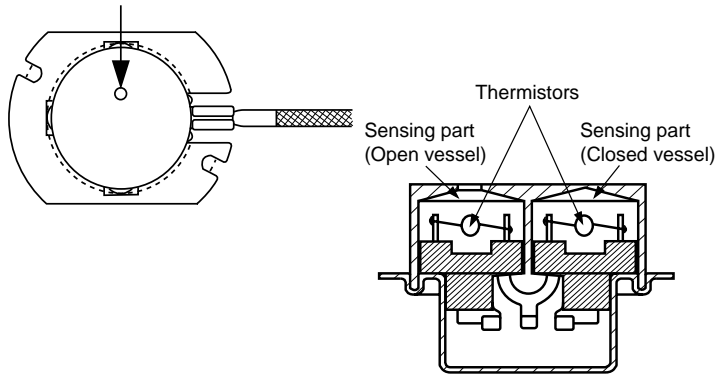

### (2) Operational Principle of Absolute Humidity Sensor

The figure below shows the basic structure of an absolute humidity sensor. A bridge circuit is formed by two thermistors and two resistors (R1 and R2).

The output of the bridge circuit is to be amplified by the operational amplifier.

Each thermistor is supplied with a current to keep it heated at about 150°C (302°F), the resultant heat is dissipated in the air and if the two thermistors are placed in different humidity conditions they show different degrees of heat conductivity leading to a potential difference between them causing an output voltage from the bridge circuit, the intensity of which is increased as the absolute humidity of the air increases. Since the output is very minute, it is amplified by the operational amplifier.

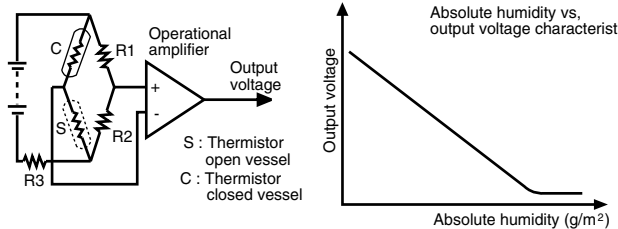

### (3) Detector Circuit of Absolute Humidity Sensor Circuit

This detector circuit is used to detect the output voltage of the absolute humidity circuit to allow the LSI to control sensor cooking of the unit. When the unit is set in the sensor cooking mode, a 16 seconds clearing cycle occurs.

Then the detector circuit starts to function and the LSI observes the initial voltage available at its AN6 terminal. With this voltage given, the switches SW1 to SW5 in the LSI are turned on in such a way as to change the resistance values in parallel with R50-1. Changing the resistance values results in that there is the same potential at both F-3 terminal of the absolute humidity sensor and AN7 terminal of the LSI. The voltage of AN6 terminal will indicate about -2.5V. This initial balancing is set up about 16 seconds after the unit is put in the Sensor Cooking mode. As the sensor cooking proceeds, the food is heated to generate moisture by which the resistance balance of the bridge circuit is deviated to increase the voltage available at AN6 terminal of the LSI.

Then the LSI observes that voltage at AN6 terminal and compares it with its initial value, and when the comparison rate reaches the preset value (fixed for each menu to be cooked), the LSI causes the unit to stop sensor cooking; thereafter, the unit goes in the next operation automatically.

After 16 seconds of operation in the sensor cook mode, the LSI detects the initial voltage at AN6. If the absolute humidity sensor is open or shorted, the circuit can not be balanced for initial voltage comparisons. This will result in the word "error" on the display and the cooking operation is stopped.

#### 1) Absolute humidity sensor circuit.

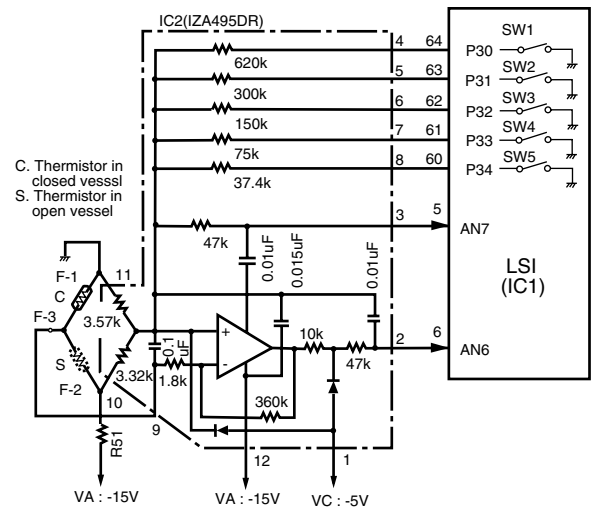

## COMPONENT REPLACEMENT AND ADJUSTMENT PROCEDURE

### WARNING AGAINST HIGH VOLTAGE

Microwave ovens contain circuitry capable of producing very high voltage and current, contact with following parts may result in severe, possibly fatal, electric shock.

(Example)

High Voltage Capacitor, Power Transformer, Magnetron, High Voltage Rectifier Assembly, High Voltage Harness etc..

**WARNING:** Avoid possible exposure to microwave energy. Please follow the instructions below before operating the oven.

1. Disconnect the power supply cord.
2. Visually check the door and cavity face plate for damage (dents, cracks, signs of arcing etc.).
6. There are defective parts in the microwave generating and transmission assembly.
7. There is visible damage to the oven.

Carry out any remedial work that is necessary before operating the oven.

Do not operate the oven if any of the following conditions exist;

1. Door does not close firmly.
2. Door hinge, support or latch hook is damaged.
3. The door gasket or seal is damaged.
4. The door is bent or warped.
5. There are defective parts in the door interlock system.

Do not operate the oven:

1. Without the RF gasket (Magnetron).
2. If the wave guide or oven cavity are not intact.
3. If the door is not closed.
4. If the outer case (cabinet) is not fitted.

### WARNING FOR WIRING

To prevent an electric shock, take the following precautions.

1. Before wiring,
  - 1) Disconnect the power supply cord.
  - 2) Open the door block it open.
  - 3) Discharge the high voltage capacitor and wait for 60 seconds.
2. Don't let the wire leads touch to the following parts;
  - 1) High voltage parts:  
Magnetron, High voltage transformer, High voltage capacitor and High voltage rectifier assembly.
  - 2) Hot parts:  
Oven lamp, Magnetron, High voltage transformer and Oven cavity.
  - 3) Sharp edge:

- Bottom plate, Oven cavity, Waveguide flange, Chassis support and other metallic plate.
- 4) Movable parts (to prevent a fault)  
Fan blade, Fan motor, Switch, Switch lever, Open button.
3. Do not catch the wire leads in the outer case cabinet.
4. Insert the positive lock connector until its pin is locked and make sure that the wire leads do not come off even if the wire leads are pulled.
5. To prevent an error function, connect the wire leads correctly, referring to the Pictorial Diagram.

Please refer to 'OVEN PARTS, CABINET PARTS, CONTROL PANEL PARTS, DOOR PARTS', when carrying out any of the following removal procedures:

### THE FOLLOWING ADJUSTMENTS OR COMPONENT REPLACEMENT CAN BE PERFORMED WITHOUT REMOVING THE OVEN FROM THE WALL

1. Hood lamps, sockets and grease filter.
2. Oven lamp, base cover and hood lamp glass assembly.
3. Turntable motor.
4. Hood exhaust louver.
5. Control panel assembly or components
6. Stirrer cover and stirrer fan.

#### HOOD EXHAUST LOUVER REMOVAL

1. Disconnect the power supply cord.
2. Open the door and block it open.
3. While holding the hood exhaust louver to the oven cavity, remove the two hood louver screws on each side.
4. The hood exhaust louver is now free and can be removed by disengaging the clips.

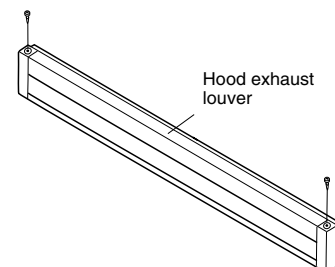

## REMOVAL OF OVEN FROM WALL (Two persons recommended to remove the oven)

1. Disconnect the power supply cord, and uncoil the power supply cord.
2. Remove the turntable tray and support from the oven cavity.
3. Remove the two (2) screws holding the oven (outer case cabinet) to the top cabinet.
4. Remove the two (2) grease filters from the base cover.
5. While supporting the front of the oven, unfasten the two (2) unit mounting screws holding the oven to the unit mounting plate.
6. Lower the front of the oven and pull the power cord out of the wall cabinet.
7. Lift the oven up off the hooks at the bottom of the mounting plate.
8. The oven is now free and can be placed on the work surface selected for servicing the oven.
9. Installation is the reverse of this procedure.

## OUTER CASE REMOVAL

Remove the oven from the wall and proceed as follows;

1. Disconnect the power supply cord.
  2. Open the door block it open.
  3. Remove one (1) screw holding the hood exhaust louver to the oven, and pull it forward to remove by pushing the right and left tabs of the hood exhaust louver. (Refer to procedure of "HOOD EXHAUST LOUVER REMOVAL".)
  4. Remove four (4) screws holding the rear stay to the hood fan motor or the oven, and remove it.
  5. Remove the four (4) screws from the rear of the outer case cabinet.
  6. Slide the outer case cabinet back about 1 inch (3 cm) to free it from retaining clips on the cavity face plate.
  7. Disconnect the three (3) pin connector of the power supply cord from the wiring harness and remove the power supply cord together with the outer case.
  8. Discharge high voltage capacitor.
- CAUTION:** 1. DISCONNECT OVEN FROM POWER SUPPLY BEFORE REMOVING OUTER CASE.  
2. DISCHARGE THE HIGH VOLTAGE CAPACITOR BEFORE TOUCHING ANY OVEN COMPONENTS OR WIRING.

## UNIT MOUNTING SCREW AND HOOD INTAKE DUCT R REMOVAL

1. Disconnect the power supply cord and remove the oven from the wall and remove the outer case of the oven.
2. Open the door block it open.
3. Bend the tab of the oven cavity back plate.
4. Lift the unit mounting screw off the tab.
5. Slide down it from the base plate right. Now , the unit mounting screw is free.
6. Remove the three (3) screws holding the hood intake duct R to the base plate right, fan duct and the oven cavity.
7. Slide the hood intake duct R out of the right side of the oven.
8. Now the hood intake duct R is free
9. Discharge the high voltage capacitor.

## POWER TRANSFORMER REMOVAL

1. Disconnect the power supply cord and remove the oven from wall, remove outer case, remove the unit mounting screw and hood intake duct R. (Refer to procedure of "Removal of Oven from Wall", "Outer Case Removal" and "Unit Mounting Screw and Hood Intake Duct R Removal".)
  2. Open the door block it open.
  3. Discharge high voltage capacitor.
  4. Disconnect filament leads of transformer from the magnetron and capacitor.
  5. Disconnect high voltage leads of capacitor from the transformer.
  6. Disconnect wire leads from transformer.
  7. Remove two (2) screws holding the transformer to base plate right.
- Re-install**
1. Rest the transformer on the base plate right with its primary terminals toward the control panel.
  2. Secure the transformer with two (2) screws to base plate right.
  3. Re-connect wire leads (primary and high voltage) to the transformer and filament leads of transformer to magnetron and high voltage capacitor. Refer to "PICTORIAL DIAGRAM".
  4. Re-install the hood intake duct R, and the outer case and
  5. check that oven is operating properly.
- CAUTION:** MAKE SURE THE WIRE LEADS NEVER TOUCH THE FAN BLADE.

## HOOD FAN MOTOR, HOOD EXHAUST DUCT AND OVEN LAMP SOCKET AND AH SENSOR REMOVAL

1. Disconnect the power supply and remove the oven from wall and remove outer case. (Refer to procedure of "Removal of Oven from Wall" and "Outer case Removal")
2. Open the door and block it open
3. Disconnect the 6-pin connector of the hood fan motor from the main wire harness located at the right edge of the hood exhaust duct.
4. Disconnect the connector CN-F from the control unit.
5. Remove three (3) screws holding the hood exhaust duct to the oven cavity.
6. Remove two (2) screws holding the hood exhaust duct to the exhaust duct.
7. Release the 6-pin connector and the 3-pin connector of the main harness A from the hood exhaust duct.
8. Release the one (1) snap band of the main harness A from the left edge of the hood exhaust duct.
9. Release the snap band of the wire cord of the hood fan motor from the hood exhaust duct.

10. Now, the hood fan motor is free.
11. Remove the hood exhaust duct from the oven cavity by lifting it up
12. Screw the oven lamp off from the lamp socket.
13. Remove the lamp socket from the lamp angle of the top duct by releasing the two (2) tabs of the oven lamp socket.
14. Pull the wire leads from the oven lamp socket by pushing the terminal hole of the oven lamp socket with the small flat type screw driver.
15. Now, the oven lamp socket is free.
16. Release the one (1) snap band of the AH sensor assembly from the oven cavity.
17. Release the one (1) tab of the top duct from the AH

- sensor assembly.
18. Remove two (2) screws holding the AH sensor assembly to the exhaust duct.
19. Now, the AH sensor assembly and the exhaust duct are free.

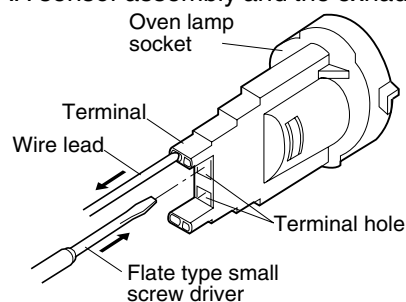

## MAGNETRON REMOVAL

1. Disconnect the power supply cord, remove the oven from wall, remove outer case, remove the unit mounting screw and hood intake duct R. (Refer to procedure of "Removal of Oven from Wall", "Outer case Removal" and "Unit Mounting Screw and Hood Intake Duct R Removal".)
2. Open the door block it open.
3. Discharge high voltage capacitor.
4. Remove the hood fan motor and the hood exhaust duct from the oven cavity, referring to the procedure of "HOOD FAN MOTOR, HOOD EXHAUST DUCT, OVEN LAMP SOCKET AND AH SENSOR REMOVAL".
5. Disconnect the high voltage wire leads of the high voltage rectifier assembly from the magnetron.
6. Disconnect the filament lead of the transformer from the magnetron.

7. Carefully remove the four (4) mounting screws holding the magnetron to waveguide. When removing the screws hold the magnetron to prevent it from falling.
8. Remove the magnetron from the unit with care so the magnetron tube should not hit by any metal object around the tube.

**CAUTION: WHEN REPLACING THE MAGNETRON, BE SURE THE R.F. GASKET IS IN PLACE AND MOUNTING SCREWS ARE TIGHTENED SECURELY.**

## HIGH VOLTAGE RECTIFIER AND HIGH VOLTAGE CAPACITOR REMOVAL

1. Disconnect the power supply cord, remove the oven from wall, remove outer case, remove the unit mounting screw and hood intake duct R. (Refer to procedure of "Removal of Oven from Wall", "Outer case Removal" and "Unit Mounting Screw and Hood Intake Duct R Removal".)
2. Open the door block it open.
3. Discharge high voltage capacitor.
4. Disconnect the high voltage wire leads with high voltage rectifier from the magnetron.
5. Disconnect filament lead of the transformer from high voltage capacitor.
6. Disconnect high voltage wire lead of capacitor from the transformer.

7. Remove one (1) screw holding capacitor holder to the back plate.
8. Remove one (1) screw holding high voltage rectifier from the capacitor holder.
9. Disconnect the high voltage rectifier assembly from the high voltage capacitor.
10. Now, the high voltage rectifier assembly is free.
11. Remove capacitor from the holder.
12. Now, the high voltage capacitor is free.

**CAUTION: WHEN REPLACING THE HIGH VOLTAGE RECTIFIER ASSEMBLY, THE GROUND SIDE TERMINAL MUST BE SECURED FIRMLY WITH A GROUNDING SCREW.**

## HOOD FAN THERMAL CUT-OUT REMOVAL

1. Disconnect the power cord, remove the oven from wall and remove outer case. (Refer to procedure of "Removal of Oven from Wall" and "Outer case Removal")
2. Open the door and block it open.
3. Discharge high voltage capacitor.

4. Disconnect the wire leads from the hood fan thermal cut-out.
5. Remove the hood fan thermal cut-out from the base plate right.
6. Now, the hood fan thermal cut-out is free.

## TEMPERATURE FUSE (MAGNETRON) REMOVAL

1. Disconnect the power supply cord, remove the oven from wall and remove outer case. (Refer to procedure of "Removal of Oven from Wall" and "Outer case Removal")
2. Open the door and block it open.
3. Discharge the high voltage capacitor.
4. Remove the hood fan motor and the hood exhaust duct from the oven cavity, referring to the procedure of "

5. Disconnect the wire leads from the temperature fuse (Magnetron).
6. Remove the one (1) screw holding the temperature fuse (Magnetron) to the oven cavity.
7. Now, the temperature fuse (Magnetron) is free.

## COOLING FAN MOTOR REMOVAL

1. Disconnect the power supply cord, remove the oven from wall and remove outer case, remove the unit mounting screw and hood intake duct R. (Refer to procedure of "Removal of Oven from Wall", "Outer case Removal" and "Unit Mounting Screw and Hood Intake Duct R Removal".)
2. Open door and block it open.
3. Discharge high voltage capacitor.
4. Remove the hood fan motor and the hood exhaust duct from the oven cavity, referring to the procedure of "HOOD FAN MOTOR, HOOD EXHAUST DUCT, OVEN LAMP SOCKET AND AH SENSOR REMOVAL".
5. Discharge high voltage capacitor.
6. Release the two (2) snaps of the magnetron duct from the oven cavity. And remove the two (2) tabs of the magnetron duct from the fan duct.
7. Release snap bands of the main harness A installed to the fan duct and nearest the fan duct.
8. Disconnect the wire leads from the fan motor.
9. Remove one (1) screw holding the fan duct assembly to oven cavity.
10. Release the fan duct assembly from the oven cavity.
11. Remove the fan blade from the fan motor shaft according the following procedure.
  - 1) Hold the edge of the rotor of the fan motor by using a pair of groove joint pliers.

### CAUTION:

- \* **Make sure that any pieces do not enter the gap between the rotor and the stator of the fan motor because the rotor is easily shaved by pliers and metal pieces may be produced.**
  - \* **Do not touch the pliers to the coil of the fan motor because the coil may be cut or injured.**
  - \* **Do not disfigure the bracket by touching with the pliers.**
- 2) Remove the fan blade from the shaft of the fan motor by pulling and rotating the fan blade with your hand.
  - 3) Now, the fan blade will be free.

### CAUTION:

- \* **Do not reuse the removed fan blade because the hole (for shaft) may be larger than normal.**
- Remove the two (2) screws holding the fan motor to the fan duct.
12. Now, the fan motor is free.

## INSTALLATION

1. Install the fan motor to the fan duct with the two (2) screws.
2. Install the fan blade to the fan motor shaft according the following procedure.
  - 1) Hold the center of the bracket which supports the shaft of the fan motor on the flat table.
  - 2) Apply the screw lock tight into the hole (for shaft) of the fan blade.
  - 3) Install the fan blade to the shaft of fan motor by pushing the fan blade with a small, light weight, ball peen hammer or rubber mallet.

### CAUTION:

- \* **Do not hit the fan blade strongly when installed because the bracket may be disfigured.**
- \* **Make sure that the fan blade rotates smooth after installation.**
- \* **Make sure that the axis of the shaft is not slanted.**

3. Install the fan duct assembly to the oven cavity with the one (1) screw.
4. Install the magnetron duct to the fan duct and oven cavity.
5. Connect the wire leads to the fan motor, referring to the pictorial diagram.
6. Reinstall the released snap bands of the main harness A to the fan duct and nearest the fan duct.
7. Refer to procedure of "HOOD FAN MOTOR, HOOD EXHAUST DUCT, OVEN LAMP SOCKET AND AH SENSOR REMOVAL" and "Unit Mounting Screw and Hood Intake Duct R Removal" and "Outer case Removal". And reverse their procedure.

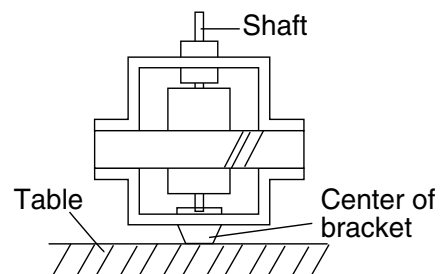
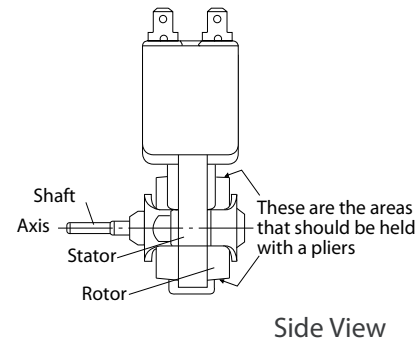
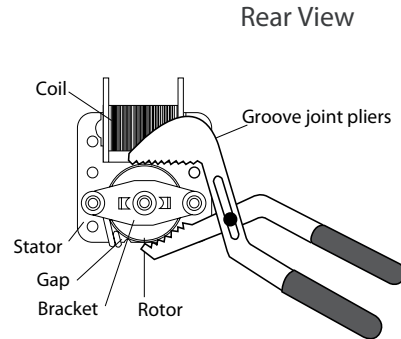

## TURNTABLE MOTOR AND COUPLING REMOVAL

1. Disconnect the power supply cord.
2. Open the door and block it open.
3. Remove the three (3) screws holding the base cover to the oven cavity
4. Remove the base cover from the oven cavity by pulling down and moving to the left slightly.
5. Disconnect the wire leads from the turntable motor.
6. Remove two (2) screws holding turntable motor to the oven cavity.
7. Now the turntable motor is free.
8. Pull the coupling out of the turntable motor packing which is installed on the oven cavity floor.
9. Now the coupling is free.

## STIRRER MOTOR REMOVAL

1. Disconnect the power supply cord and remove the oven from wall and remove outer case. (Refer to procedure of "Removal of Oven from Wall" and Outer case Removal")
2. Open the door and block it open.
3. Discharge high voltage capacitor.
4. Remove the hood fan motor and the hood exhaust duct from the oven cavity, referring to the procedure of "HOOD FAN MOTOR, HOOD EXHAUST DUCT, OVEN LAMP SOCKET AND AH SENSOR REMOVAL".
5. Disconnect the wire leads from the stirrer motor.
6. Remove the two (2) screws holding the stirrer motor to the waveguide of the oven cavity.
7. Remove the stirrer motor from the waveguide.
8. Now, the stirrer motor is free.
9. When install the stirrer motor, the shaft of stirrer motor must be inserted to the stirrer fan shaft. Refer to the procedure of "STIRRER COVER AND STIRRER FAN INSTALLATION".

## STIRRER COVER AND STIRRER FAN INSTALLATION

1. Insert the shaft of stirrer fan to the shaft of stirrer motor.
2. Hold the stirrer fan not to come out from the shaft of stirrer motor.
3. Insert the cutout of stirrer cover to the tabs on the ceiling.
4. Put the stirrer fan on the stirrer cover to match the stirrer fan shaft to the center of the stirrer support.
5. Hold the stirrer cover to the oven cavity with the two (2) screws.

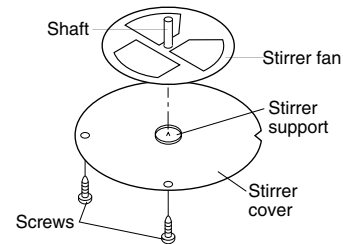

## NOISE FILTER REMOVAL

1. Disconnect the power supply cord and then remove outer case.
2. Open the door and block it open.
3. Discharge high voltage capacitor.
4. Disconnect the wire leads from the terminals of the noise filter .
5. Remove one (1) screw mounted into the noise filter bracket.

## OVEN LAMP REMOVAL

1. Disconnect the power supply cord.
2. Remove one (1) screw holding the hood exhaust louver to oven cavity front flange.
3. Remove the hood exhaust louver from the oven by disengaging the clips on the hood exhaust louver. (Refer to procedure of "HOOD EXHAUST LOUVER REMOVAL")
4. Lift the oven lamp cover up.
5. Now, the oven lamp and the socket are found.
6. Screw the oven lamp off from the lamp socket.
7. Now, the oven lamp is free.

NOTE: HOT (YELLOW) WIRE MUST BE CONNECTED TO THE TERMINAL WITH BLUE MARKING ON LAMP SOCKET.

## CONTROL PANEL ASSEMBLY, CONTROL UNIT AND KEY UNIT REMOVAL

1. Disconnect the power supply cord.
2. Open the door and block it open.
3. Remove one (2) screws holding the hood exhaust louver to oven cavity front flange.
4. Remove the hood exhaust louver from the oven by disengaging the clips on the hood exhaust louver. (Refer to procedure of "HOOD EXHAUST LOUVER REMOVAL")
5. Open the oven door.
6. Remove one (1) screw holding the control panel to the oven cavity front face plate.
7. Release the control panel from the oven cavity front face plate by lifting it up.
8. Disconnect the wire leads from the relays RY1, RY2 and RY3.
9. Disconnect the connectors CN-A, CN-B CN-C, CN-E and CN-F from the control unit.
10. Remove the control panel assembly from the oven.
11. Now, the control panel assembly is free.
12. Remove four (4) screws holding the control unit to the control panel.
13. Release the two (2) tabs holding the control unit to the control panel.
14. Now, the control unit is free.

15. Remove the one (1) screw holding the key fixing plate to the control panel.
16. Release the four (4) tabs holding the key fixing plate to the control panel.
17. Remove the key fixing plate from the control panel.
18. Tear the key unit from the key fixing plate.
19. Now, the key unit is free

#### NOTES FOR KEY UNIT REPLACEMENT

1. Do not reuse the torn key unit because the performance of the adhesive becomes weak.
2. Before attaching a new key unit, wipe off remaining adhesive on the key fixing plate surfaces completely with a soft cloth soaked in alcohol.
3. When attaching the key unit to the key fixing plate, adjust the upper edge and right edge of the key unit to the correct position of key fixing plate.
4. Stick the key unit firmly to the key fixing plate by rubbing with soft cloth not to scratch.

#### NOTES FOR NEW CONTROL UNIT REPLACEMENT

1. Before installation of the new CPU into the control panel, grasp the middle section between thumb and finger, bend the display board forward until b breaks as shown in step 1.
2. To remove the middle section push both sides of the middle section towards d until c breaks as shown in step 2.

#### NOTE: Discard the middle section.

3. After removing the middle section, bend the display board 90°, positioning the jumper wires into the notches of the display board as shown in step 3.

4. Insert the bottom edge of the display board under the tab of control panel as shown in step 4.
5. Place the top edge of the display board on the clip (F). And press the display board downward as shown in step 4. (Holes in middle of display board should be positioned into locator pins.)
6. After installing display board, press the CPU downward 90° until CPU is locked into place by the clips.
7. Hold the CPU with the four (4) screws.
8. After installing CPU, make sure jumper wires are not bent, touching or broken.

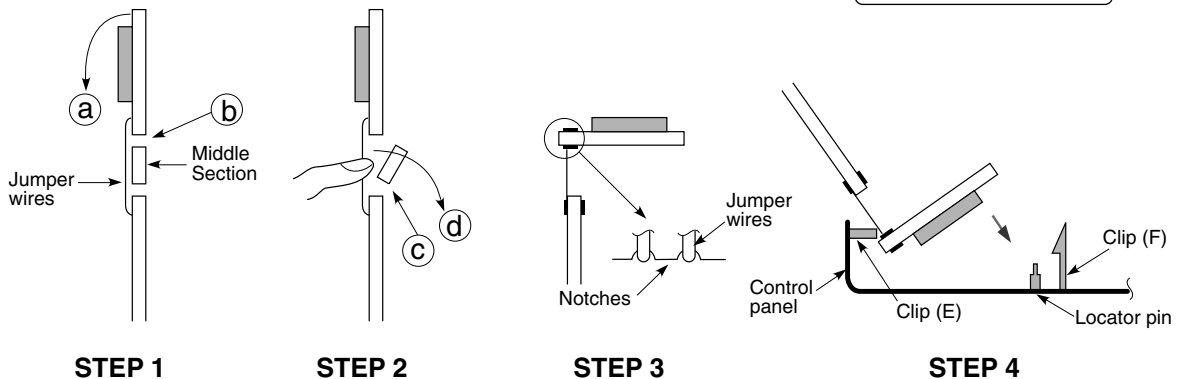
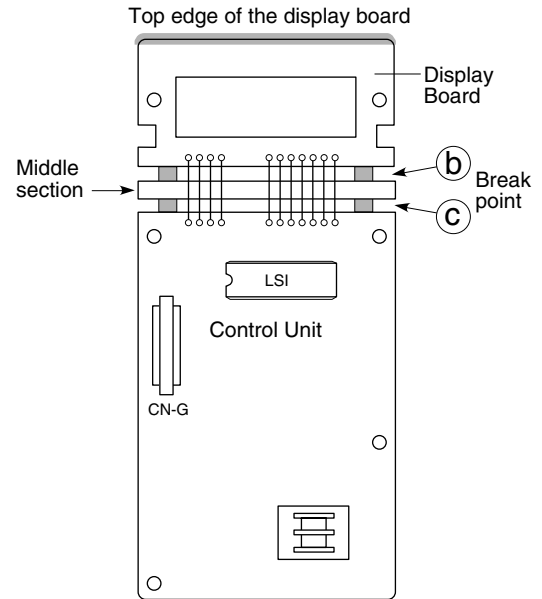

### POSITIVE LOCK® CONNECTOR (NO-CASE TYPE) REMOVAL

1. Disconnect the power supply cord and remove the oven from wall and remove outer case. (Refer to procedure of "Removal of Oven from Wall" and Outer case Removal")
2. Open the door and block it open.
3. Discharge high voltage capacitor.
4. Pull down on the positive lock® connector.
5. Push the lever of positive lock®

**CAUTION:** WHEN CONNECTING THE POSITIVE LOCK® CONNECTORS TO THE TERMINALS, INSTALL THE POSITIVE LOCK® SO THAT THE LEVER FACES YOU.

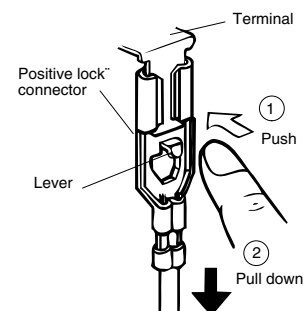

**Positive lock® connector**

## CONVECTION DUCT ASSEMBLY REMOVAL

1. Disconnect power supply cord, remove the oven from wall and remove outer case. (Refer to procedure of "Removal of Oven from Wall" and Outer case Removal")
2. Open the door and block it open.
3. Discharge high voltage capacitor.
4. Lift the left mounting screw off the tab and slide it down from the base plate left.
5. Remove the one (1) screw holding the exhaust duct to the top duct.
6. Remove the exhaust duct from the oven cavity.
7. Remove the heat protect top sheet from the top duct.
8. Remove the two (2) screws holding the hood intake duct L to the heater cover L and the oven cavity front flange.
9. Disconnect the wire leads from the convection motor and heater element.
10. Disconnect the connector of the main wire harness A from the connector of the thermistor.

### THERMISTOR REMOVAL

11. Remove one (1) screw holding the thermistor to the convection duct.
12. Now, the thermistor is now free.

### CONVECTION HEATER REMOVAL

13. Remove six (6) oven side screws holding the convection duct to the oven cavity.
14. Remove two (2) screws holding the convection duct to the oven cavity top side.
15. Remove two (2) screws holding the two heater mounting holders to the convection duct.
16. Remove two (2) screws holding the convection heater to the convection duct.
17. Now, the convection heater is now free.

**NOTE:** After installed the heating element completely,

### DAMPER MOTOR AND DAMPER SWITCH REMOVAL

1. Disconnect the power supply, remove the oven from wall, remove outer case, remove the unit mounting screw and hood intake duct R. (Refer to procedure of "Removal of Oven from Wall", "Outer case Removal" and "Unit Mounting Screw and Hood Intake Duct R Removal".)
2. Open the door and block it open.
3. Discharge the high voltage capacitor.

### DOOR SENSING SWITCH, SECONDARY INTERLOCK SWITCH, THIRD DOOR SWITCH AND MONITOR SWITCH REMOVAL

1. Disconnect the power supply cord and remove the oven from wall and remove outer case. (Refer to procedure of "Removal of Oven from Wall" and "Outer case Removal")
2. Open the door and block it open.
3. Discharge high voltage capacitor.
4. Remove the hood fan motor and the hood exhaust duct from the oven cavity, referring to the procedure of "HOOD FAN MOTOR, HOOD EXHAUST DUCT, OVEN LAMP SOCKET AND AH SENSOR REMOVAL".
5. Remove the control panel assembly, referring to the procedure of "CONTROL PANEL ASSEMBLY, CONTROL UNIT AND KEY UNIT REMOVAL".
6. Bend the tab of the oven cavity face plate which prevent the open lever from coming out.

**bent top of the heating element holder to inside using by long nose pliers as shown following illustration.**

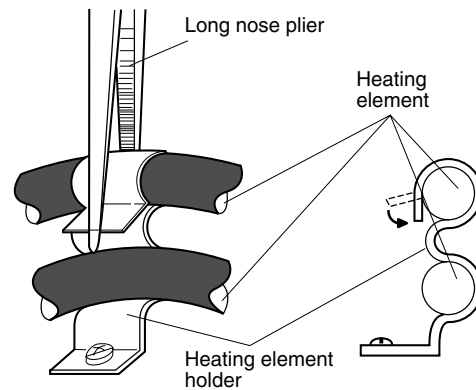

### CONVECTION FAN AND MOTOR REMOVAL

18. Remove one (1) nut (turn to clockwise), spring washer and washer holding the convection fan to the convection motor shaft.
19. Now, the convection fan is now free.
20. Remove two (2) washers and pipe holding the convection motor fan to convection motor shaft.
21. Remove two (2) screws holding the convection motor mounting plate to convection duct.
22. Remove the convection motor assembly, convection motor fan and one (1) washer from the convection duct.
23. Remove the convection motor fan and one (1) washer holding the fan to convection motor shaft.
24. Remove the E-ring from the convection motor shaft.
25. Remove two (2) screws holding the convection motor to convection motor mounting plate.
26. Now, the convection motor is free.

4. Disconnect wire leads from damper motor and damper switch.
5. Remove one (1) screw holding damper motor to damper motor angle and bend the tab holding damper switch to damper motor angle.
6. Damper motor and switch are free.

7. Remove the open lever from to the oven cavity.
8. Remove the two (2) screws holding the latch hook to the oven cavity front flange.
9. Remove the latch hook from the oven cavity front flange.
10. Disconnect the wire reads of each switch.
11. Remove each switch from the latch hook with pushing the one (1) stopper tub holding each switch.
12. Now, each switch is free.

### Re-install

1. Re-install open lever and each switch in its place. The secondary and third door switch in the lower position, door sensing switch is in the upper position and the monitor switch is in the middle position.
2. Re-connect wire leads to each switch. Refer to pictorial



3. Secure the latch hook (with two (2) mounting screws) to oven cavity front flange.
4. Make sure that the monitor switch is operating properly and check continuity of the monitor circuit. Refer to chapter "Test Procedure" and "Adjustment procedure".

## DOOR SENSING SWITCH, SECONDARY, THIRD DOOR SWITCH AND MONITOR SWITCH ADJUSTMENT

If the door sensing switch, secondary, primary switch and monitor switch do not operate properly due to a misadjustment, the following adjustment should be made.

1. Disconnect the power supply cord and remove the oven from wall and remove outer case. (Refer to procedure of "Removal of Oven from Wall" and "Outer case Removal")
2. Open the door and block it open.
3. Discharge high voltage capacitor.
4. Loosen the two (2) screws holding latch hook to the oven cavity front flange.
5. With door closed, adjust latch hook by moving it back and forth, and up and down. In and out play of the door allowed by the upper and lower position of the latch hook should be less than 0.5mm. The vertical position of the latch hook should be adjusted so that the door sensing switch, secondary and third door switch are activated with the door closed. The horizontal position of the latch hook should be adjusted so that the monitor switch is activated with the door closed.
6. Secure the screws with washers firmly.
7. Check the all switches operation. If the any switch has not activated with the door closed, loosen screw and adjust the latch hook position.

### After adjustment, check the following.

1. In and out play of door remains less than 0.5mm when in the latched position. First check upper position of latch hook, pushing and pulling upper portion of door toward the oven face. Then check lower portion of the latch hook, pushing and pulling lower portion of the door toward the oven face. Both results (play in the door) should be less than 0.5mm.

2. The door sensing switch, secondary and third door switch interrupt the circuit before the door can be opened.
3. Monitor switch contacts close when door is opened.
4. Re-install outer case and check for microwave leakage around door with an approved microwave survey meter. (Refer to Microwave Measurement Procedure.)

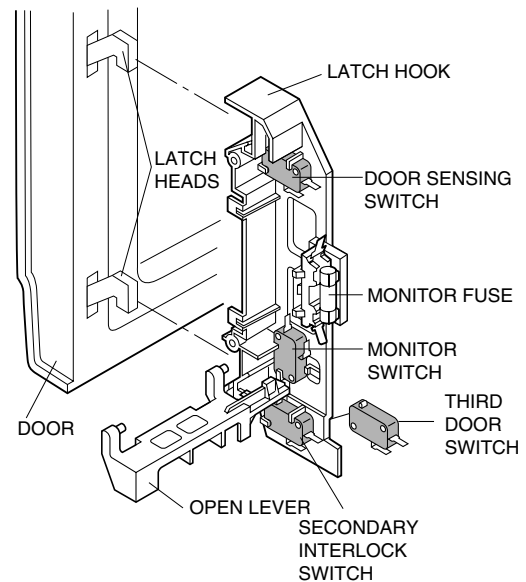

## DOOR REPLACEMENT

### DOOR ASSEMBLY REMOVAL

1. Unplug the oven from power outlet and remove the oven from wall and remove outer case. (Refer to procedure of "Removal of Oven from Wall" and "Outer case Removal")
2. Remove one (1) screw holding the hood exhaust louver to the oven cavity with outer case cabinet, as shown in Figure C-2.
3. Remove the hood exhaust louver from the oven cavity by pushing right and left tabs of the hood exhaust louver, as shown in Figure C-2.
4. Remove the sash left from the oven cavity from face plate by lifting it up.
5. Push the door open button and open the door slightly.
6. Insert a putty knife (thickness of about 0.5mm) into the gap A between the door stopper and the choke cover as shown in Figure C-3 to free engaging parts.
7. Lift up the door stopper.

8. Now, the door stopper is free from the door assembly.
9. Lift up the door assembly to release the upper and lower door hinge pins from the upper and lower oven hinges.
10. Now, the door assembly is free.

**Note:** When the individual parts are replaced, refer to "Door Disassembly".

### DOOR ASSEMBLY RE-INSTALL

1. On re-installing door, insert the lower oven hinge to lower door hinge pin.
2. Insert the upper oven hinge to the upper door hinge pin.
3. Shut the door (close the contacts of interlock switches).
4. Make sure upper and lower oven hinges are inserted into the upper and lower door hinge pins.
5. Make sure the door is parallel with oven face lines (left and upper side lines) and door latch heads pass through latch holes correctly.

6. Re-install the door stopper to the door assembly.
7. Re-install the sash left to the oven cavity front face plate.
8. Re-install the hood exhaust louver to the oven cavity front face plate.

**Note:** After any service to the door;

- (A) Make sure that door sensing switch and secondary interlock switch are operating properly. (Refer to chapter "Test Procedures".)
- (B) An approved microwave survey meter should be used to assure compliance with proper microwave radiation emission limitation standards.

**After any servicing, make sure of the following :**

1. Door latch heads smoothly catch latch hook through latch holes and that latch head goes through center of latch hole.
2. Deviation of door alignment from horizontal line of cavity face plate is to be less than 1.0mm.
3. Door is positioned with its face pressed toward cavity face plate.
4. Re-install outer case and check for microwave leakage around door with an approved microwave survey meter. (Refer to Microwave Measurement Procedure.)

**Note:** The door on a microwave oven is designed to act as an electronic seal preventing the leakage of

microwave energy from oven cavity during cook cycle. This function does not require that door be air-tight, moisture (condensation)-tight or light-tight. Therefore, occasional appearance of moisture, light or sensing of gentle warm air movement around oven door is not abnormal and do not of themselves, indicate a leakage of microwave energy from oven cavity.

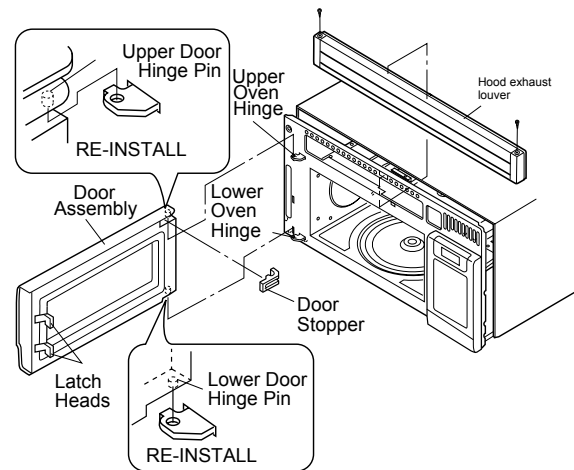

**Figure C-2. Door Replacement and adjustment**

## DOOR DISASSEMBLY

1. Disconnect the power supply cord and remove the oven from wall and remove outer case. (Refer to procedure of "Removal of Oven from Wall" and "Outer case Removal")
2. Open the door and block it open.
3. Discharge high voltage capacitor.
4. Remove the hood exhaust louver from the oven by disengaging the clips on the hood exhaust louver. (Refer to procedure of "HOOD EXHAUST LOUVER REMOVAL")
5. Remove door assembly, refer to "Door Replacement". Replacement of door components are as follows:
6. Place door assembly on a soft cloth with latches facing up.

**Note:** As the engaging part of choke cover and door panel are provided at 17 places, do not force any particular part.

### CHOKE COVER

7. Insert an putty knife (thickness of about 0.5mm) into the gap between the choke cover and door panel and between the choke cover and the door frame as shown Figure C-3 to free engaging parts.
8. Try the principles of the lever and lift up the choke cover by inserting a putty knife in order shown in Figure C-3.
9. Now choke cover is free from door panel and door frame.

### DOOR FRAME

10. Remove six (6) screws holding the door panel to the door frame assembly.
11. Release the door frame assembly from the door panel.
12. Now, door frame assembly is free.

### LATCH SPRING, LATCH HEAD AND DOOR PANEL

13. Release the latch spring from the tab of the latch head and tab of the door panel.
14. Release the latch head from the door panel.
15. Now, the latch spring, latch head and door panel are free.

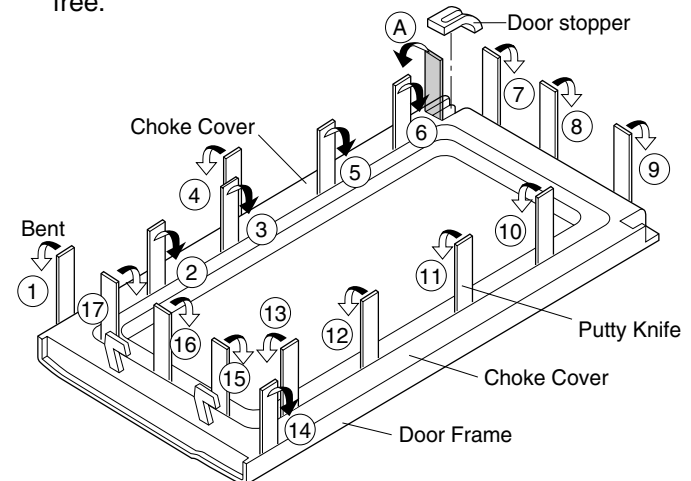

**Figure C-3. Door Disassembly**

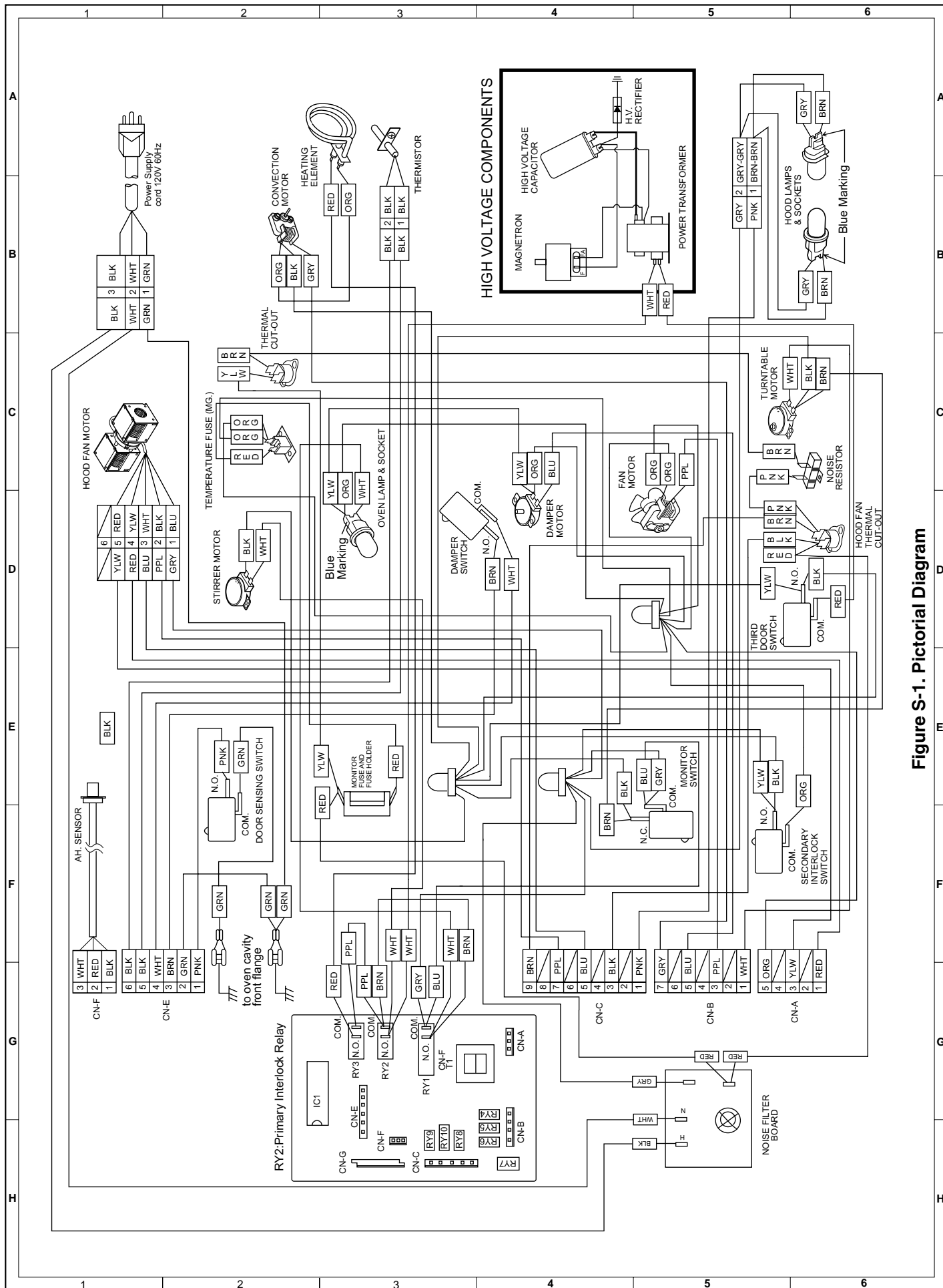

Figure S-1. Pictorial Diagram

# VIKING

COPYRIGHT © 2012 BY VIKING RANGE CORPORATION

ALL RIGHTS RESERVED.

No part of this publication may be reproduced, stored in retrieval systems, or transmitted in any form or by any means, electronic, mechanical, photocopying, recording, or otherwise, without prior written permission of the publisher.