

**SERVICE MANUAL
FREE STANDING GAS RANGE**



VIKING RANGE CORPORATION ®

TABLE OF CONTENTS

Viking Model Numbers.....	2		
Viking Serial Number logic.....	3	Top Burner Ignitor Removal.....	25
Viking Product Warranty.....	4	Spark Module Removal.....	25
Proximity to Side Cabinets Installation.....	6	Indicator Light Removal.....	26
Gas Connections.....	7	Bake / Broil Thermostat Removal.....	26
Rangetop Cutout and Specifications.....	8	Oven Ignitor Removal.....	26
Range Leveling.....	9	Broil Gas Valve Removal.....	26
Combustion of Gas.....	10	Oven Gas Valve Removal.....	26
BTU Requirements.....	12	Top Burner Valve Replacement.....	27
Gas Conversion.....	13	Pressure Regulator Removal.....	27
I / R Broiler Spud (Orifice) Change.....	14	Convection Fan Removal.....	27
Surface Burner Adjustments.....	15	Oven Burner Removal.....	27
Oven Burner Adjustments.....	16	Broil Burner Removal.....	28
Grill / Griddle Burner Adjustment.....	17	Broil Ignitor Removal.....	28
Oven Temperature Calibration Chart.....	18	Indicator Light.....	28
Oven Thermostat / Calibration.....	19	Oven Light Switch.....	28
Silicon Carbide (Glow-Coil) Ignition.....	20	Oven Light Switch Removal.....	28
Door Removal.....	21	Oven Gasket Removal.....	28
Oven Door Assembly.....	22	Convection Fan Removal.....	28
Hinge and Logo Removal.....	22	Oven Light Removal.....	29
Door Hinge Removal.....	22	Grill Burner Removal.....	29
Oven Door Parts.....	22	Grill Ignitor Removal.....	29
Control Panel Removal.....	23	Griddle Thermostat Removal.....	29
Landing Ledge Removal.....	23	Trouble Shooting Guide.....	30
Component Location.....	24	Griddle Repair Kit (12") griddle.....	34
Top Burner Removal.....	25	Griddle Repair Kit (24").....	35
		Wiring Diagram (Rangetops).....	36
		Wiring Diagram (convection Ranges).....	37

NEW VIKING MODEL NUMBERS

RANGES AND RANGETOPS

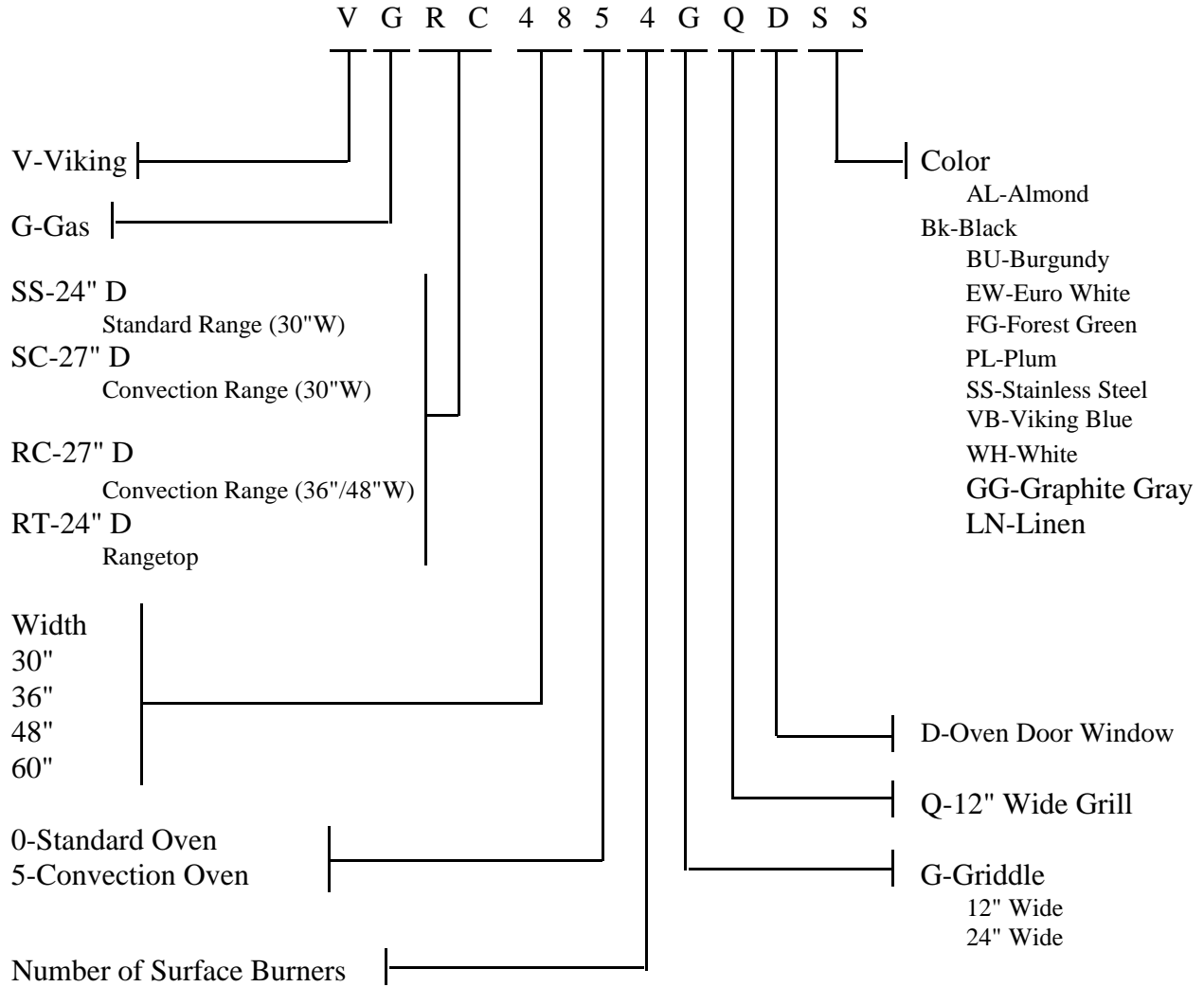

**VIKING SERIAL NUMBER LOGIC
JULY 24, 1995 BAR CODE**

RANGES AND 36" WIDE OVENS

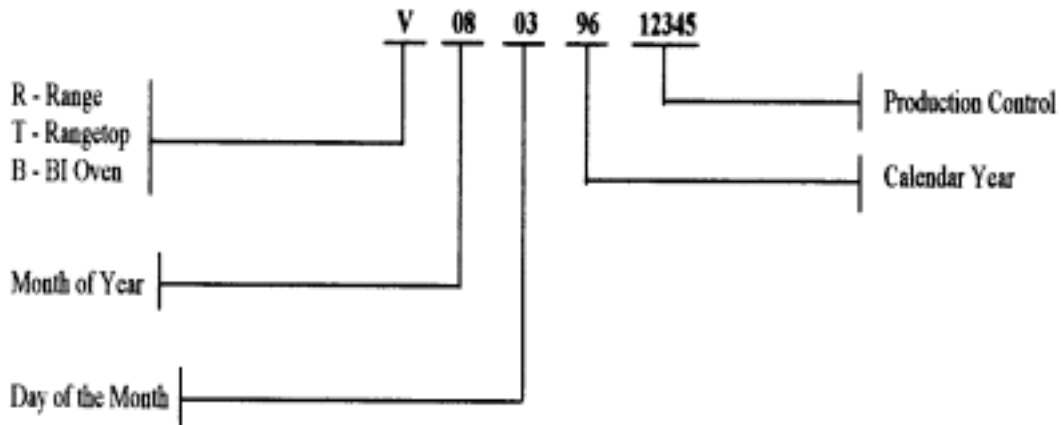

27" W. OVENS

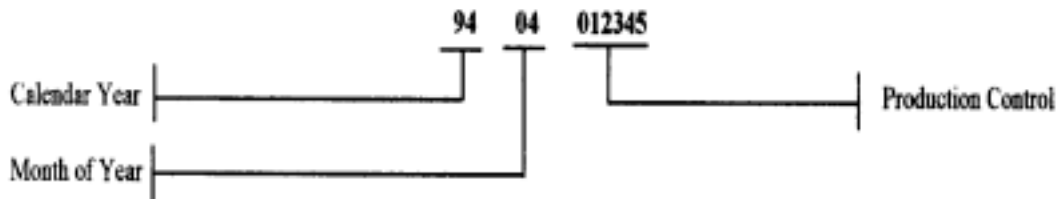

**VIKING RANGE CORPORATION
PRODUCT WARRANTY**

COOKING PRODUCTS

FREE STANDING GAS RANGES

- * 90 DAYS-GLASS, PAINTED, PORCELAIN AND DECORATIVE ITEMS
- * 1 YEAR FULL WARRANTY-COMPONENTS AND ACCESSORIES
- * 5 YEAR LIMITED WARRANTY-SURFACE BURNER, GRIDDLE TUBULAR BURNER, GRILL TUBULAR BURNER (PART ONLY)
- * 10 YEAR LIMITED WARRANTY-ANY PORCELAIN OVEN OR PORCELAIN INNER DOOR WHICH **RUSTS THROUGH**

DUAL FUEL RANGES

- * 90 DAYS-GLASS, PAINTED, PORCELAIN AND DECORATIVE ITEMS
- * 1 YEAR FULL WARRANTY-COMPONENTS AND ACCESSORIES
- * 5 YEAR LIMITED WARRANTY-SURFACE BURNER, GRIDDLE TUBULAR BURNER, GRILL TUBULAR BURNER, BAKE ELEMENT, BROIL ELEMENT, OR CONVECTION COOK ELEMENT (PART ONLY)
- * 10 YEAR LIMITED WARRANTY-ANY PORCELAIN OVEN OR PORCELAIN INNER DOOR PANEL WHICH **RUSTS THROUGH**

ELECTRIC RANGES

- * 90 DAYS-GLASS, PAINTED, PORCELAIN AND DECORATIVE ITEMS
- * 1 YEAR FULL WARRANTY-COMPONENTS AND ACCESSORIES
- * 5 YEAR-ANY HALOGEN ELEMENT, BAKE ELEMENT, BROIL ELEMENT, OR CONVECTION COOK ELEMENT (PART ONLY)
- * 10 YEAR LIMITED WARRANTY-ANY PORCELAIN OVEN OR PORCELAIN INNER DOOR PANEL WHICH **RUSTS THROUGH**

GAS RANGETOPS

- * 90 DAYS -GLASS, PAINTED, PORCELAIN AND DECORATIVE ITEMS
- * 1 YEAR FULL WARRANTY-COMPONENTS AND ACCESSORIES
- * 5 YEAR LIMITED WARRANTY-SURFACE BURNERS, GRIDDLE TUBULAR BURNER, GRILL TUBULAR BURNER (PART ONLY)

ELECTRIC RANGETOP

- * 90 DAYS-GLASS, PAINTED, PORCELAIN AND DECORATIVE ITEMS
- * 1 YEAR FULL WARRANTY-COMPONENTS AND ACCESSORIES
- * 5 YEAR-ANY HALOGEN ELEMENT, BAKE ELEMENT, BROIL ELEMENT, OR CONVECTION COOK ELEMENT (PART ONLY)

GAS WALL OVENS

- * 90 DAYS-GLASS, PAINTED, PORCELAIN AND DECORATIVE ITEMS
- * 1 YEAR FULL WARRANTY-COMPONENTS AND ACCESSORIES

- * 5 YEARS-OVEN TUBULAR BURNER (PART ONLY)
- * 10 YEAR LIMITED WARRANTY-ANY PORCELAIN OVEN OR PORCELAIN INNER DOOR PANEL WHICH **RUSTS THROUGH**

ELECTRIC WALL OVENS

- * 90 DAYS-GLASS, PAINTED, PORCELAIN AND DECORATIVE ITEMS
- * 1 YEAR FULL WARRANTY-COMPONENTS AND ACCESSORIES
- * 5 YEARS LIMITED WARRANTY-OVEN BAKE, BROIL, OR CONVECTION HEATING ELEMENTS
- * 10 YEAR LIMITED WARRANTY-ANY PORCELAIN OR PORCELAIN INNER DOOR PANEL WHICH **RUSTS THROUGH**

WARMING DRAWERS

- * 90 DAYS-PAINTED AND DECORATIVE ITEMS
- * 1 YEAR FULL WARRANTY-COMPONENTS AND ACCESSORIES
- * 5 YEAR LIMITED WARRANTY-HEATING ELEMENT

VENTILATION PRODUCTS

- * 90 DAYS-PAINTED AND DECORATIVE ITEMS
- * 1 YEAR FULL WARRANTY-COMPONENTS AND ACCESSORIES
- * 2 YEAR LIMITED WARRANTY-BLOWER MOTOR OR EXTERIOR VENTILATOR MOTOR

KITCHEN CLEAN-UP

DISHWASHER

- * 90 DAYS-PAINTED OR DECORATIVE ITEMS
- * 1 YEAR FULL WARRANTY-COMPONENTS AND ACCESSORIES
- * 5 YEAR LIMITED WARRANTY-MOTOR/PUMP AND WATER DISTRIBUTION SYSTEM COMPONENTS
 - * CIRCULATION PUMP
 - * DRAIN MOTOR/PUMP
 - * FILL VALVE
 - * LOWER WASH ARM
 - * TUBE TO UPPER WASH ARM
 - * UPPER WASH ARM
- * 25 YEAR LIMITED WARRANTY-STAINLESS STEEL TANK OR INNER DOOR LINER WHICH DEVELOPS A WATER LEAK

TRASH COMPACTORS

- * 90 DAYS-PAINTED OR DECORATIVE ITEMS
- * 1 YEAR FULL WARRANTY-COMPONENTS AND ACCESSORIES
- * 5 YEAR LIMITED WARRANTY-DRIVE SYSTEM MOTOR

DISPOSERS

- * VCFW 1020 AND VBFW
- * 7 YEAR FULL WARRANTY
- * VCHW 1000 AND VBHW 1030
- * 5 YEAR FULL WARRANTY

PRODUCT WARRANTY (CONTINUED)

REFRIGERATION PRODUCTS

REFRIGERATION

- * 90 DAYS-PAINTED OR DECORATIVE ITEMS
- * 2 YEARS FULL WARRANTY
- * 6 YEARS FULL WARRANTY ON SEALED SYSTEM COMPONENTS
 - * COMPRESSOR
 - * CONDENSER
 - * DRYER/STRAINER
 - * EVAPORATOR
 - * CONNECTING TUBING
- * 12 YEAR LIMITED WARRANTY-SEALED SYSTEM COMPONENT (PARTS ONLY)
 - * COMPRESSOR
 - * CONDENSER
 - * DRYER/STRAINER
 - * EVAPORATOR
 - * CONNECTING TUBING

ICE MAKER

- * 90 DAYS-PAINTED OF DECORATIVE ITEMS\
- * 2 YEAR FULL WARRANTY
- * 6 YEAR FULL WARRANTY ON SEALED SYSTEM COMPONENT
 - * COMPRESSOR
 - * CONDENSER
 - * DRYER/STRAINER
 - * EVAPORATOR
 - * CONNECTING TUBING
- * 12 YEAR LIMITED WARRANTY-SEALED SYSTEM COMPONENT (PART ONLY)
 - * COMPRESSOR
 - * CONDENSER
 - * DRYER/STRAINER
 - * EVAPORATOR
 - * CONNECTING TUBING

WINE COOLER

- * 90 DAYS-PAINTED OR DECORATIVE ITEMS
- * 2 YEAR FULL WARRANTY
- * 6 YEAR FULL WARRANTY ON SEALED SYSTEM COMPONENT
 - * COMPRESSOR
 - * CONDENSER
 - * DRYER/STRAINER
 - * EVAPORATOR
 - * CONNECTING TUBING
- * 12 YEAR LIMITED WARRANTY-SEALED SYSTEM COMPONENT (PART ONLY)
 - * COMPRESSOR
 - * CONDENSER
 - * DRYER/STRAINER
 - * EVAPORATOR
 - * CONNECTING TUBING

OUTDOOR PRODUCTS

GAS GRILLS

- * 90 DAY-PAINTED, PORCELAIN, AND DECORATIVE ITEMS
- * 1 YEAR FULL WARRANTY
- * 5 YEAR LIMITED WARRANTY-CAST IRON BURNER ASSEMBLIES, INFRARED ROTISSERIE BURNERS, AND PORCELAIN GRILL GRATES
- * LIFETIME WARRANTY-STAINLESS STEEL PART WHICH **RUST THROUGH**

PROXIMITY TO SIDE CABINET INSTALLATION

1. This range may be installed directly adjacent to existing 36" high base cabinets.
IMPORTANT- the top grate support **MUST BE** 3/8" above the adjacent base cabinet countertop. This may be accomplished by raising the unit using the adjustment spindles on the legs. (The countertops **CANNOT** be higher than 37 1/2" due to the high BTU burners.)
2. The range **CANNOT** be installed directly adjacent to sidewalls, tall cabinets, tall appliances, or other side vertical surfaces above 36" high. There must be a minimum of 6" side clearance from the range to such combustible surfaced above the counter height.
3. Within the 6" side clearance to combustible vertical surfaces above 36", the maximum wall cabinet depth must be 13" and wall cabinets within 6" side clearance must be 18" above the 36" high countertop.
4. Wall cabinets above the range must be a minimum of 36" above the range cooking surface for the full width of the range.

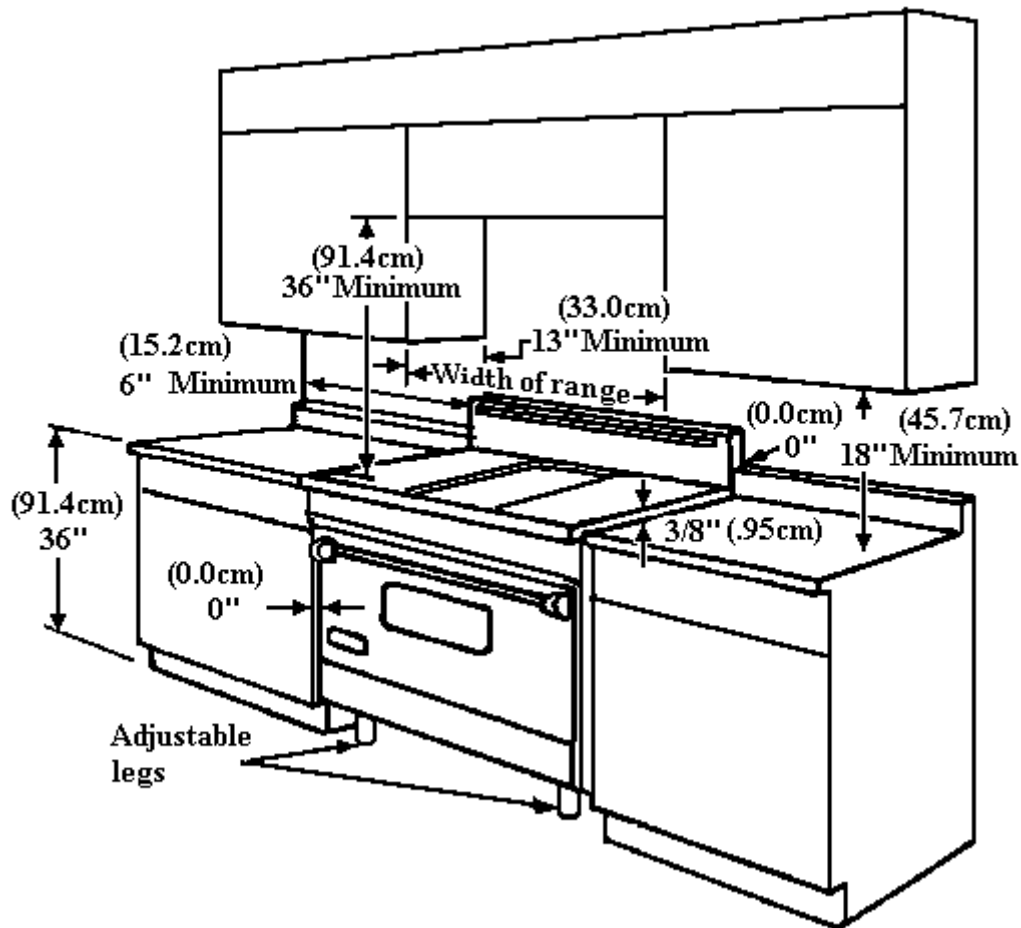

	30" W Models	36" W Models	48" W Models	60" W Models
Overall Width	29 7/8" (75.9cm)	35 7/8" (91.1cm)	47 7/8" (121.6cm)	59 1/2" (151.1cm)

GAS CONNECTIONS

The gas supply (service) line must be the same size or greater than the inlet line of the appliance. This range uses a ½" I.D. NPT (Sch40) inlet. Sealant on all pipe joints must be resistive to Lp gas.

1. Manual Shut-off Valve:

This installer supplied valve must be installed in the gas service line ahead of the appliance and regulator in a position where it can be reached quickly in the event of an emergency.

2. Pressure Regulator:

a) All heavy-duty, commercial-type cooking equipment must have a pressure regulator on the incoming service line for safe and efficient operation, since service pressure may fluctuate with local demand. External regulators are not required on this range, because a regulator is built into each unit at the factory. **UNDER NO CONDITION BYPASS THIS BUILT-IN REGULATOR.**

b) Any conversion required must be performed by your dealer or a qualified licensed plumber or gas service company. Please provide the service person with this manual before work is started on the range.

(**GAS CONVERSIONS ARE THE RESPONSIBILITY OF THE DEALER OR END USER.**)

c) This range can be used with Natural gas or LP/Propane. It is shipped from the factory adjusted for use with natural gas. The orifice hoods must be screwed snug when LP/Propane is used. (See LP/Propane conversion).

d) Manifold pressure should be checked with a manometer, natural gas requires 5.0"WC and LP gas requires 10.0"WC. Incoming line pressure upstream from the regulator must be 1.0"WC higher than the manifold pressure in order to check the regulator. The regulator used on this range can withstand a maximum input pressure of ½ PSI (14.0" WC). If the line pressure is in excess of that amount, a step-down regulator will be required.

e) The appliance, its individual shut-off valve, and pressure regulator must be disconnected from the gas supply piping system during any pressure testing of that system at pressures in excess of 1/2psig (3.45kPa).

f) The appliance must be isolated from the gas supply piping system by closing its individual manual shut-off valve during any pressure testing of the gas piping system at test pressures equal to or less than ½ psig (3.45kPa).

3. Flexible Connections:

a) If the unit is to be installed with flexible couplings and/or quick-disconnect fittings, the installer must use a heavy duty, A.G.A. design certified commercial flexible connector of at least ½" ID NPT (with suitable strain reliefs) in compliance with ANSI Z21.69.

b) **In Canada:** CAN 1-6. 10-88 metal connectors for gas appliance and CAN 1-6.9 M79 quick disconnect devices for use with gas fuel.

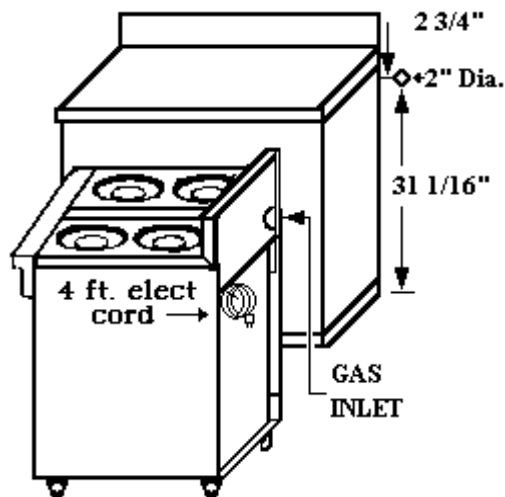

RANGETOP CUTOUT and SPECIFICATIONS

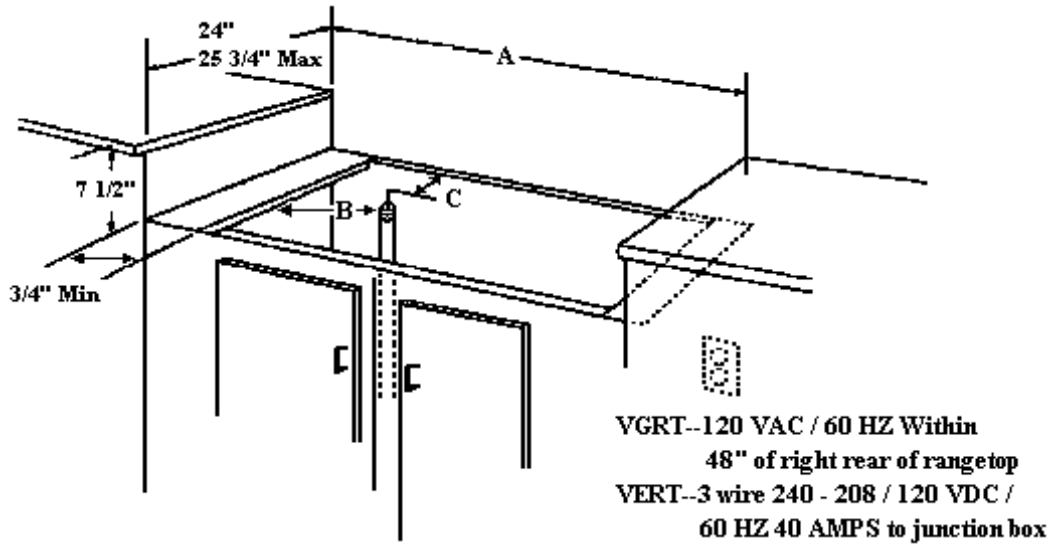

VGRT	A	B	C
30" W. MODELS	30" (76.2 cm)	3" (7.6cm)	2 1/4" (5.7 cm)
36" W. MODELS	36" (91.4 cm)	3" (7.6 cm)	2 1/4" (5.7 cm)
48" W. MODELS	48" (121.9 cm)	3" (7.6 cm)	2 1/4" (5.7 cm)
60" W. MODELS	59 1/2" (151.4 cm)	14 3/8" (36.5 cm)	9/16" (1.8 cm)

1. Gas Line Requirements:

- a. Gas pipe size should be 3/4" (1/2" inside diameter)
- b. Gas pipe should be 3" or less from floor and 6" from left to center of unit to allow for the flex line.
 - i.e. 30" range 6"-15" from left 48" range 6"-24" from left
 - 36" range 6"-15" from left 60" range 6"-30" from left

If it is higher than 3" from the floor, the range will not fit flush against the wall and The shutoff valve will not be accessible.

2. Electrical Requirements: Gas ranges, gas rangetops, and Gas cooktops require a 120 volt electrical outlet (GFI ground fault outlet not recommended).

- a. 3" or less from the floor and 6" from the right to center of the unit.
 - i.e. 30" range 6"-15" from right 48" range 6"-24" from right
 - 36" range 6"-18" from right 60" range 6"-30" from right

RANGE LEVELING

Careful leveling of the range is critical not only to performance, but also to allow the alignment of oven doors and drip tray. Closely follow the procedures below to ensure proper performance and appearance of the range. The range being even slightly out of level will significantly contribute to misalignment of oven doors.

1. If the floor is smooth and level, level the unit with the screw thread of the legs. Set the high corner of the range so that the top of the grate support is 3/8" above the countertop, and level the range to the high corner.
2. If the floor is uneven or has a decided slope, level the unit with metal shims, as the adjustment required may exceed the thread available in the leg.
3. Proper and careful leveling of the range is necessary for proper alignment of the oven doors.
 - The body of the range does not have a rigid frame to hold it into one position. This non-rigid framework allows the range to shift with un-level floors or slanted cabinets.
 - Moving any one of the adjustable leveling legs up or down will shift the range body. Use the vertical line between the edge of the door and the left side trim or center trim on the 2 door models to adjust the leveling legs.

When adjusted properly this space will be uniform from the top to the bottom of the door. The bottom corner of the end panel will move in or out. Adjust this lower corner to have an equal space from the top to the bottom of the door.

- Increasing the length of the right front leveling leg will raise the right front corner of the range, moving the top of the door to the left. Lowering the right front leveling leg will cause the top of the door to move to the right.
 - Using the left front leveling leg will give you the opposite effect. Raising the left front corner will move the top of the door to the right. Lowering the corner will move the top of the door to the left. The rear leveling legs will also have an effect on the door alignment.
4. After the range is properly leveled, the drip tray handle may be aligned by loosening the screws and adjusting the handle horizontally within the limits provided by the slotted screw holes.

5. A carpenter's spirit level should be placed across the top of the range and the unit leveled front-to back, side-to side and vertically. If it is not level, burner combustion may be erratic, liquid or semi-liquid batters will cook at an angle, and the unit may not function efficiently.

- A. Right Side
Front / Back
Adjustable Legs
- B. Left Side
Front / Back
Adjustable Legs

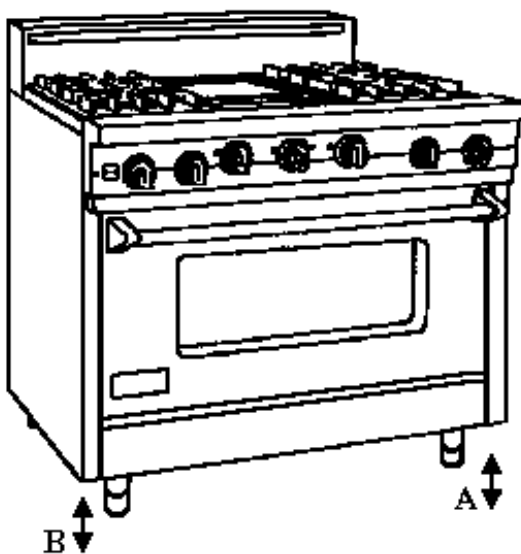

COMBUSTION OF GAS

- A. **The Meaning of Combustion** - When oxygen acts with a substance to produce large amounts of heat rapidly (and usually light), the process is called combustion or burning.
- B. **Requirements for Combustion** - Three things needed for combustion to take place are fuel, oxygen (air) and heat (temperature). All must be present. Take away any one of the three and burning will stop. Gas ignition temperature is approximately 1100 - 1200 degrees Fahrenheit.
- C. **Basic Chemistry of Combustion** - Combustion of gas is a chemical reaction between fuel gas and oxygen. The basic elements of common fuel gases are hydrogen (H) and Carbon (C). When hydrogen burns, water vapor (H₂O) is produced. Complete burning of carbon in fuel gases form carbon dioxide (CO₂). Complete combustion produces harmless carbon dioxide (CO₂) and water vapor (H₂O).
Water is produced as a vapor in the burning of gas. If the flue products remain hot enough, water is discharged as vapor to the outside through vent system. If the flue products should become cool, as in an air conditioned room, this water vapor will condense out as a liquid on any cooler surface. The temperature at which water forms from vapor is known as the dew-point.
- D. **Controlled Combustion** - Controlled combustion takes place when fuel gas and air are supplied at proper rates to assure complete combustion (burning) of the gas in a steady flame. When a gas appliance is operating properly, burning starts at the burner ports. Gas flow is controlled by a gas orifice size and by gas pressure upstream of the orifice. Burners which have some air premixed with the gas before it passes through the BURNER PORTS are called "blue flame" burners. This air added to the gas is called primary air. The rest of the air required for complete combustion is supplied to the burner flames in the COMBUSTION CHAMBER and is called SECONDARY AIR.
Adjustments of gas rate and primary air provide the key to obtaining stable, blue flames on the burner using primary air. AIR SHUTTERS or other devices provide control of primary air. Proper amounts of primary and secondary air are needed for quiet and efficient appliance operation and for complete combustion of the gas. Size of the inlet openings and flue outlets control secondary air flow.
- E. **Explosive Combustion** - An explosion is simply very rapid burning which is not under control.
- F. **Limits of Flammability** - Not all air-gas mixtures will burn. Mixtures with zero to four percent natural gas in air are too lean to burn. Mixtures of four to fourteen percent natural gas in air can burn with a controlled flame.
Flammability Limits are of interest to those dealing with problems and everyday operations in the gas industry. For example consider, FLASHTUBE ignition of rangetop burners. A gas-air mixture from the burner head passes through a charge port into the open end of the flashtube. This mixture is too rich to burn without secondary air, but some air also enters the flashtube at the entrance. The additional air causes the mixture to become leaner to a composition that is flammable. When the mixture travels down the tube to point of ignition, the flame will carry back from the lighter to the charge port and light the gas at the burner. If the mixture in the flashtube has too much gas (too rich) or has too much air (too lean), the burner will not light.
Flammability Limits also enter the picture when primary air adjustments are made on burners. For example, Infra-red (radiant) burners usually operate with about 100 percent primary air. In other word the gas air mixture in the burner head contains all the air ideally required for complete combustion. If too much primary air is used, the mixture may become too lean and fall outside the lower flammability limit and it will not burn on the burner surface.
Unburned gas should not be allowed to collect in combustion chambers or confined spaces because gas-air mixture within the flammability limits will explode if ignited.
- G. **Incomplete Combustion - Causes and Effects**
To obtain complete combustion enough air must be supplied to the process. This air must have a Reasonably normal oxygen content. Complete burning of gas produces harmless carbon dioxide and water vapor. If not enough air is supplied other products will form. Some of these products are harmful, especially carbon monoxide.

COMBUSTION OF GAS (CONTINUED)

It is vital that an appliance venting system do its job. The importance of providing enough fresh air to the room in which and appliance is located can not be stressed too strongly.

Carbon monoxide is a toxic gas. It can cause death if enough of it is inhaled. This gas has no odor, color or taste, so that it cannot be detected by bodily senses. Inhaled carbon monoxide is absorbed into the blood. It combines with hemoglobin in the blood to a much greater extent than oxygen and remains in the blood longer than oxygen does. In doing so, it acts to reduce the oxygen-carrying function of the blood. Thus, a person exposed to carbon monoxide can die if a lack of oxygen.

Carbon monoxide is only one product of incomplete combustion. ALDEHYDES, another class of compounds, also may be formed in incomplete combustion. While carbon monoxide is odorless, Aldehydes have a sharp, penetrating odor. They are readily detected by smell, even at very low concentrations. The odor of aldehydes differs from odorants added to natural gas and the two should not be confused. The absence of aldehydes does not assure that carbon monoxide is not present. However, if the odor of aldehydes is present, then carbon monoxides almost always will be present, aldehydes themselves also are toxic.

H. **GAS BURNER OPERATION** - A gas burner is a device to burn gas under control to produce useful heat.

Primary air is brought into the burner from outside the appliance at atmosphere pressure. The gas jet streaming from the orifice draws or injects primary air into the burner.

PRIMARY AIR: Air which is mixed with gas before the gas leaves a burner port to burn.

SECONDARY AIR: Air externally supplied to a burner flame at the point of combustion.

I. **BURNER COMPONENTS**

Gas Orifice - An opening or hole, regulates or limits the amount of gas flowing to a burner. Gas flow rate (volume) depends on the size of the orifice (hole) and gas pressure at the inlet of the orifice.



UNIVERSAL GAS ORIFICES

FIXED (SPUD) ORIFICE

Air Shutter - This is used to adjust the size of the openings to control primary air flow.

Venturi Throat - A section in a pipe or a burner body that narrows down and then flares out again. This neck helps maintain a more constant primary air injection.

Mixing Tube - Serves to carry the air-gas mixture from the venturi throat to the burner head.

Burner Head - Contains the burner ports, and provides uniform distribution of the air-gas mixture to those ports.

Burner Ports - Distributes flames to provide good heat transfer. They spread the flames so they can be reached by secondary air. They provide stable, blue flames.

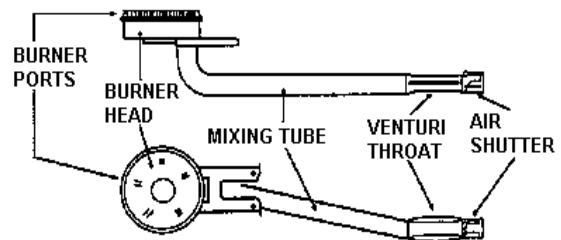
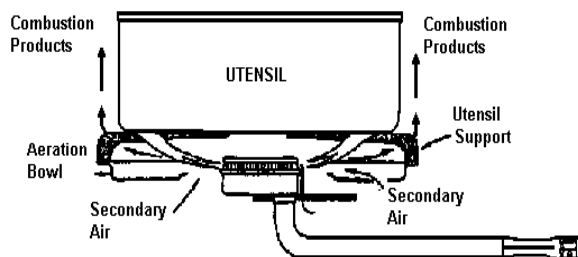

VIKING RANGE BTU REQUIREMENTS

Determine the size of piping or tubing required for the two stage LP Gas installation shown.

Total of the first stage piping length equal 26 feet; first stage regulator setting is 10 psig. From "aa" to "a", demands equal 338,000 BTU/hr., use ½" pipe, ½" tubing, or ½" T plastic pipe. (This is determined by using a gas range with a total of 65,00 BTU usage. **See below for the BTU ratings of the Viking ranges.**)

Total second stage piping length equal 50 feet.

- From a to b, demand = 338,000 BTU/hr, use 1" pipe.
- From b to c, demand = 138,000 BTU/hr, use ¾" pipe or 7/8" tubing.
- From c to d, demand = 100,000 BTU/hr, use ½" pipe or 1/4" tubing.
- From d to e, demand = 35,000 BTU/hr, use ½" pipe or ½" tubing.
- From b to f, demand = 200,000 BTU/hr, use ¾" pipe.
- From c to g, demand = 38,000 BTU/hr, use ½" pipe or 5/8" tubing.
- From d to n, demand = 65,000 BTU/hr, use ½" pipe or 5/8" tubing.

Total BTU's required for each Viking range by model number.

VGR30	75,000	VGSS300	105,000
VGR36-4G	103,000	VGSC305	108,000
VGR36-6B	128,000	VGRC365	138,000
VGR48-4G	130,000	VGRC485	183,000
VGR48-6G	145,000	VGRC605	203,000
VGR48-8B	160,000		

The size of the LP supply tank should be calculated by the total number of BTU requirements of the gas appliance.

The pressure supplied from the LP supply tank should be between *12 WCI and *14 WCI. The regulator on your Viking range will supply a steady *10 WCI to the manifold.

*WCI - Water column inches.

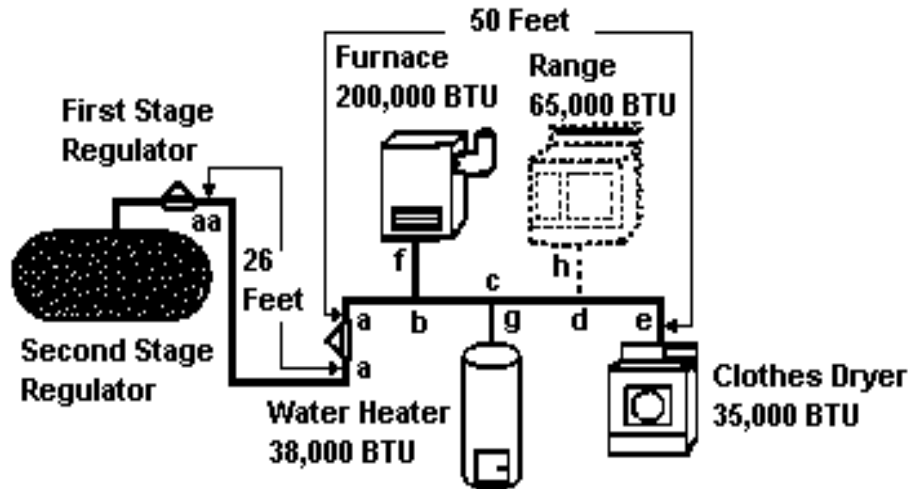

NATURAL GAS TO LP/PROPANE CONVERSION INSTRUCTIONS

This product is manufactured and adjusted for operation with natural gas as shipped from the factory. To operate with LP/Propane gas, the following adjustments must be made.

- A pressure regulator is located in the left rear corner of the burner box. To gain access to the pressure regulator, remove the two left grates, two burner bowls, and the left grate support. Convert the regulator by removing the cap marked "NAT" and reverse it to read "LP". Be sure not to disturb or remove the spring beneath the cap.



ILLUSTRATION # 1

- To convert surface, griddle, grill, bake, and tubular burners to LP/Propane, turn the burner orifice hoods clockwise until they become snug against the internal LP/Propane pin orifice, (See Illustration #2). After adjusting the oven burner orifice hoods (Illustration #3, Item "3") for LP gas, it may be necessary to shift the burner from position "4" to position "5" (Illustration #3) on the burner mounting bracket. This will properly position the orifice hood in the burner venturi.



ILLUSTRATION #2

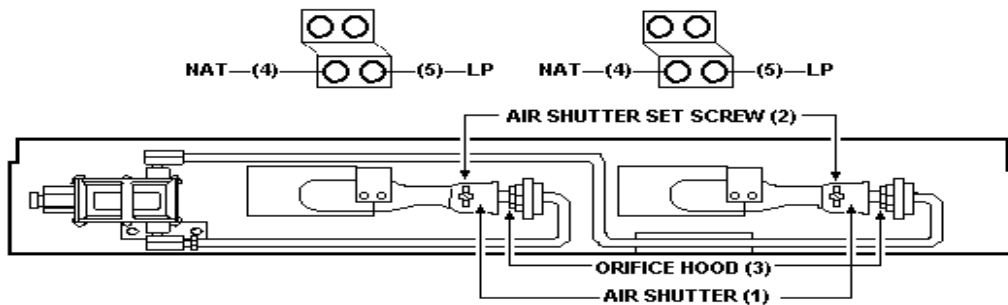

ILLUSTRATION #3

- The orifice spud for INFRARED broilers has to be physically changed. Remove the #47 orifice spud and replace with the #56 orifice spud (see Illustration #2) that is attached to the infrared broil burner gas supply tubing. Attach the natural gas #47 orifice spud to the gas supply tubing for future use should the product need to be reconverted to natural gas. **Note: Changing the infrared fixed (spud) orifice must be completed before the range is placed into the space provided.**

INFRARED BROILER ORIFICE SPUD CHANGE

The orifice change is accomplished by:

1. Turning the gas off at the shut-off valve
2. Removing the range from the cabinets
3. Remove the back guard from the range
4. Locating the gas supply line at the end of the broiler venturi
5. Remove and replace the orifice spud located at the end of the gas supply tube
6. Reverse steps 3-2-1
7. Check the operation of the infrared broiler

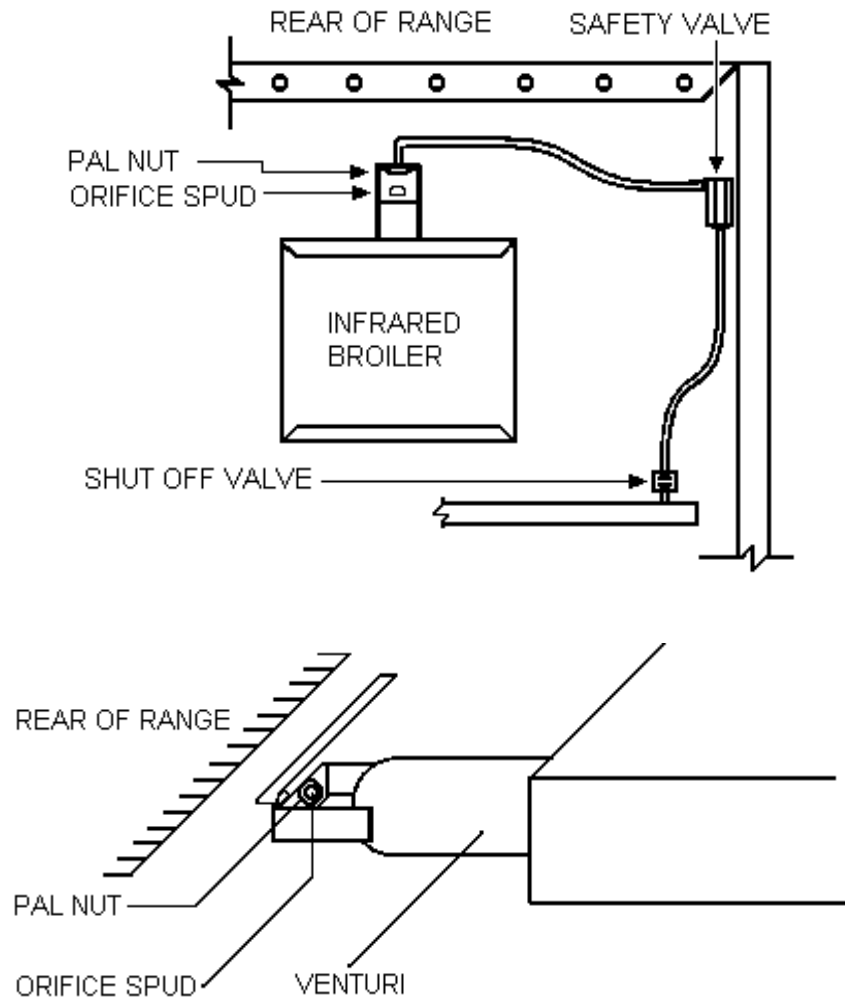

SURFACE BURNER ADJUSTMENTS

To gain access to the surface burner adjustments:

1. Remove the grates, burner caps, burner bowls, and grate supports.
2. Locate the air shutter "A" and loosen screw "B" that holds the air shutter in place.
3. Remove the drip tray, allowing you work space to adjust the orifice hood "C".
4. Replace the grate support and burner bowls (this allows for correct air flow, as in normal use).
5. Light each burner by rotating the burner valve shaft "D" to high position.
6. Use a ½" deep socket to adjust the orifice hood on Nat. gas only (LP tighten to fixed orifice); turn clockwise to decrease the flame and counter clockwise to increase the flame.
7. With the proper flame height, adjust the air shutter "A" to obtain a blue flame (with no yellow tipping)
 - a) Open the air shutter gap to eliminate yellow tipping.
 - b) Close the air gap to prevent a noisy flame that lifts off the burner ports.
8. Turn the surface burner off.
9. Replace the drip tray.
10. Remove the grate support and burner bowls.
11. Tighten the air shutter screws "B".
12. Replace the grates, burner caps (if applicable), burner bowls and grate supports.
13. Relight each burner and turn to the low flame setting.
14. Remove knob.
15. Insert a narrow, flat blade screwdriver into the hollow shaft of the surface burner valve, and engage the slotted low flame adjustment screw. The low flame should be a small flame the comes just to the edge of the burner rim. Rotate the adjusting screw "E" clockwise to lower the flame or clockwise to increase the flame. Turn the burner off and relight several times, turning to the low position. The flame should light at every port each time. Readjust as needed.

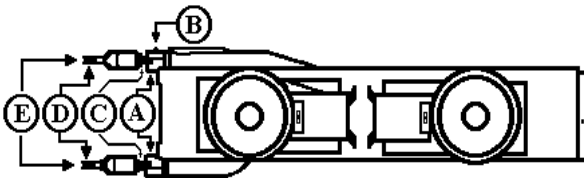

A. Air Shutter D. Burner Valve Shaft
 B. Air Shutter Set Screw E. Adjusting Screw
 C. Orifice Hood



Surface Burner

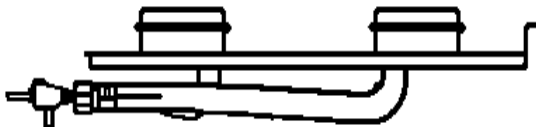

BURNER ASSEMBLY

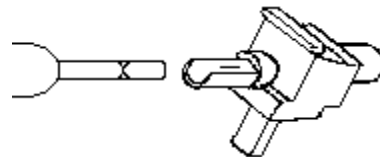

LOW FLAME ADJUSTMENT

OVEN TUBULAR GAS BURNER ADJUSTMENTS

Check the gas supply, and set the regulator to the proper supply of gas. A properly adjusted burner should be stable and quiet. The flame should have a sharp, well defined blue inner cone with no yellow tipping. The flame should also be stable and uniform with no flames lifting off the burner ports.

To gain access to the oven burner adjustments:

1. Remove the kick plate - remove screw from each side of the kick plate and tilt the top of the kick plate forward.
2. Locate the air shutter (illustration #1, item "1") and loosen the set screw (illustration #1, item "2") that holds the air shutter in place.
3. Light the burners by rotating the thermostat to a baking temperature.
4. Using a 1/2" open end wrench, adjust the orifice hood (illustration #1, item "3") to obtain a sharp well defined blue inner cone approximately 1/2" long. The flame should be contacting the burner at each port opening. **THE FLAME SHOULD NOT EXTEND INTO THE OVEN BOTTOM VENT SLOTS.**
5. With a proper flame height, adjust the air shutter (illustration #1, item "1") to obtain a blue flame with no yellow tipping that contacts the burner at the burner ports.
 - a) Open the air shutter gap (illustration #1, item "1") to eliminate yellow tipping.
 - b) Close the air shutter gap (illustration #1, item "1") to prevent a noisy flame that lifts off the burner ports.
6. Recheck the orifice hood (illustration #1, item "3") adjustment for proper gas flow.
7. Turn the thermostat control to off.
8. Tighten the air shutter set screw (illustration #1, item "2").
9. Relight each burner and observe the flame for proper adjustments. If necessary, repeat the above.
10. Turn the convection fan on and observe that the flame does not lift off the burner ports, readjust the air shutter gap with the convection fan running.
11. Replace the kick plate.

IMPORTANT: Conditions that cause odors:

- a). Floating flames are lazy looking and not have a well defined inner cone. They are long, ill defined, quiet flames that sometimes lift completely off the ports and cause a strong and pungent odor.
- b). Lifting flames are well defined, hard and noisy that lift completely off the ports.
- c). An orifice that is out of line with the burner venturi.

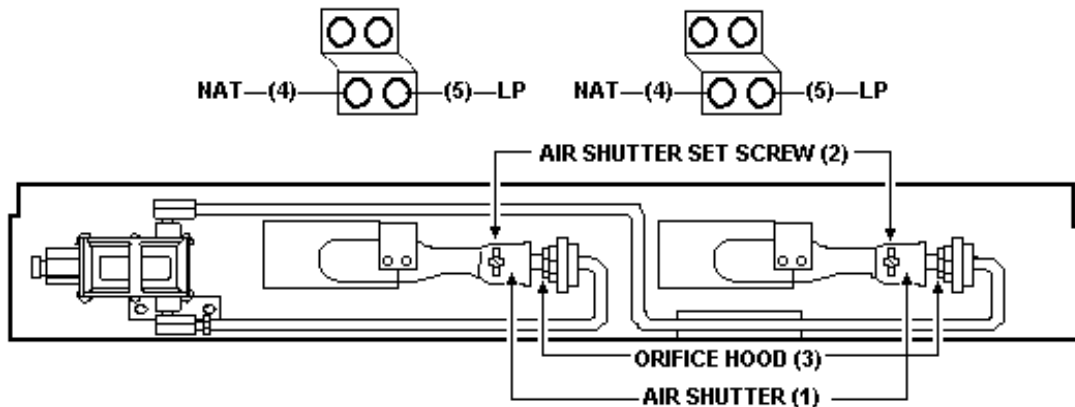

ILLUSTRATION #1

GRILL / GRIDDLE BURNER ADJUSTMENT

GRILL (Item "A")

1. The grill burner orifice and air shutter are located beneath the front end of the grill assembly. To gain access to the adjustments, remove the grill grate, grate support, flame spreader and the burner shield.
2. Remove the screw at the front and rear of the burner.
3. Lift the burner off the orifice and locate the air shutter adjustment screw at the end of the burner.
4. Loosen the screw and adjust the air shutter to the desired setting (for natural gas open shutter approximately $\frac{1}{2}$ "; for LP/Propane gas open the air shutter approximately $\frac{9}{16}$ ").
5. Tighten the screw, then replace burner on the orifice.
6. Check flame for desired height before replacement of the above parts.
7. The flame adjustments are the same as the surface burners. Use a $\frac{1}{2}$ " deep socket to adjust the orifice hood on natural gas only (LP tightened to the fixed orifice); turn clockwise to decrease the flame and counter clockwise to increase the flame.

GRIDDLE (Item "B")

1. To gain access to the burner orifice and air shutter, remove grates and grate supports located on either side of the griddle. Lift and remove griddle plate.
2. Carefully remove ignitor and put to the side.
3. Remove the metal plate located below the burner.
4. Remove the screws at the front and rear of the burner remove the burner tube and locate the air shutter adjustment screw at the end of the burner tube.
5. Flame adjustments are the same as the grill - see #4 and #7 under grill.
6. Replace the griddle plate.

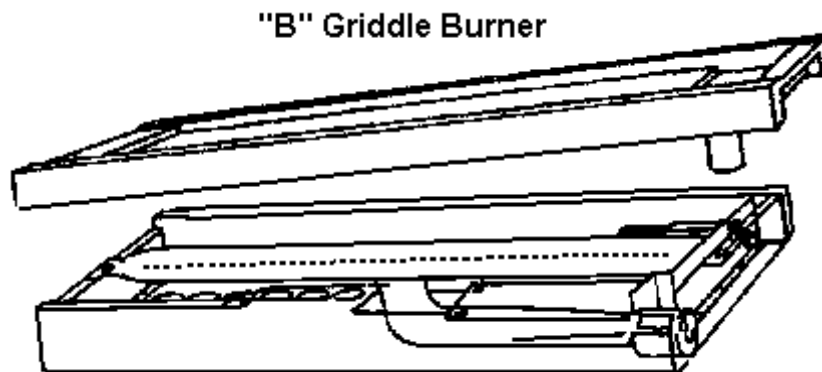
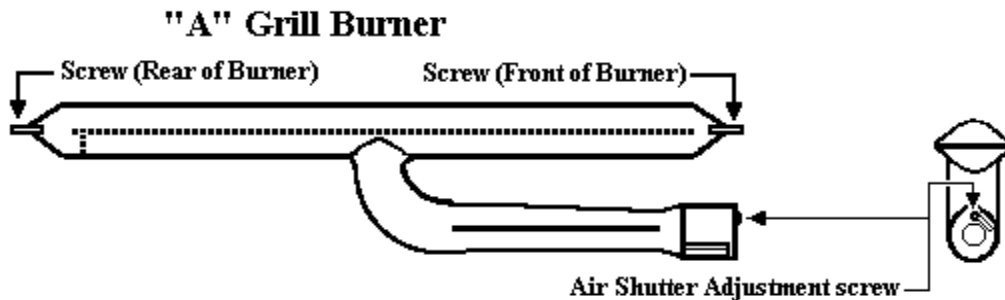

OVEN TEMPERATURE CALIBRATION

- A. Monitor house voltage during test.
 - 1. Must maintain at 117 VAC
From _____ to _____
- B. Monitor igniter (glo-coil) current during test.
 - 1. Must maintain 3.4 amps or greater.
From _____ to _____
- C. Monitor voltage across the thermal valve connectors.
 - 1. Must be between 3.03 and 3.3 volts A.C.
From _____ to _____
- D. Check gas pressure at the manifold (burner orifice). Light a burner during test to equalize pressure.
 - 1. Check to make sure 1/2" Inside Diameter (ID) supply line to the product.
 - 2. NAT _____ WCP must be 5" WCP.
 - 3. L.P. _____ WCP must be 10" WCP.

Supply pressure from the meter or L.P. tank must be at least 6" WCP for natural gas or 11" WCP for L.P. gas. Pressure should never exceed 14" WCP or 1/2 PSI.

- E. Be sure the thermostat bulb is straight and properly spaced from the oven liner. The sensor bulb clips should be in place.
- F. Place a weighted thermo-couple in the center of the oven cavity.
- G. Set oven temperature control to 350°F. Oven temperature should reach 350°F in 10 minutes.
- H. Cycle oven 5 times: Average 3rd, 4th and 5th cycles. Temperature is acceptable if the average is 350°F -15F +25°F.

TEMPERATURE; Conventional Oven

	Cycle	1	2	3	4	5	Average
High	(XX)	(XX)	()	()	()	()	()
Low	(XX)	(XX)	()	()	()	()	()

- I. For convection test lower temperature to 325°F. Pre heat oven with convection fan on.

TEMPERATURE: Convection Oven

	Cycle	1	2	3	Average
High	(XX)	()	()	()	()
Low	(XX)	()	()	()	()

- J. On conventional baking place pans in the center of the oven.
- K. On convection baking place pans on rack positions 2 and 4.
- L. Uneven temperatures left to right in oven.
 - 1. Check air shutter adjustment; sharp blue flame, no yellow tipping.
 - 2. Check orifice hood adjustment.

OVEN THERMOSTAT

The oven thermostat maintains the correct oven temperatures in the bake and broil operations.

In bake operation, thermostat contacts close completing the bake circuit through the bake ignitor, and bake gas valve to neutral.

In broil operation, thermostat contacts close completing the broil circuit through the broil ignitor and broil gas valve to neutral.

The thermostat contacts can be checked for continuity by using a continuity tester or an ohmmeter set to the low ohms range. Power to the oven must be turned off and the thermostat wiring removed when checking the contacts for continuity. Access to the thermostat contacts can be made by removing the control panel. Replace the thermostat if the switch contacts are defective.

THERMOSTAT CALIBRATION

Use the Oven Calibration Chart to determine the need for a calibration. (See the preceding page.)

1. Remove the thermostat control knob.
2. Remove the silicone gel from thermostat shaft.
3. Turn adjusting screw counter clockwise to increase the temperature. (1/4 turn equals 37°F. DO NOT TURN MORE THAN 1/4 TURN.)
4. Turn adjusting screw clockwise to decrease the temperature. (1/4 turn equals 37°F. DO NOT TURN MORE THAN 1/4 TURN.)
5. Follow the instructions on the Oven Calibration Chart to calibrate oven temperature. (See the preceding page.)

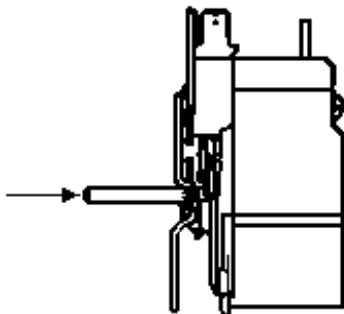

**THERMOSTAT CENTER
STEM ADJUSTMENT**

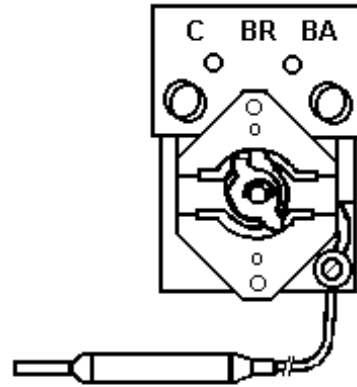

THERMOSTAT FRONT VIEW

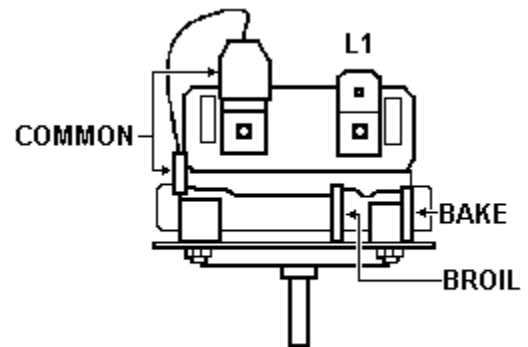

THERMOSTAT END VIEW

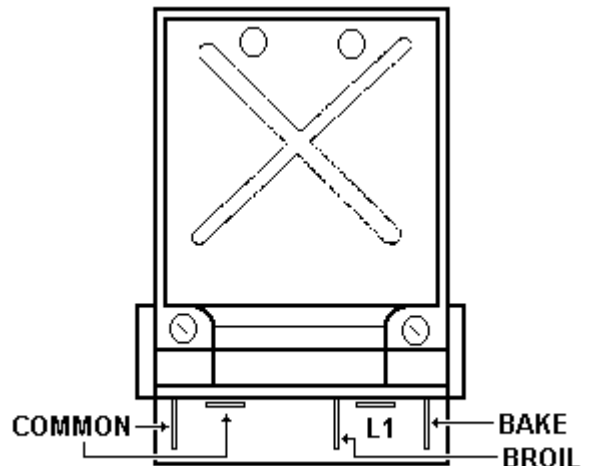

THERMOSTAT - REAR VIEW

SILICON CARBIDE (GLO-COIL) IGNITION

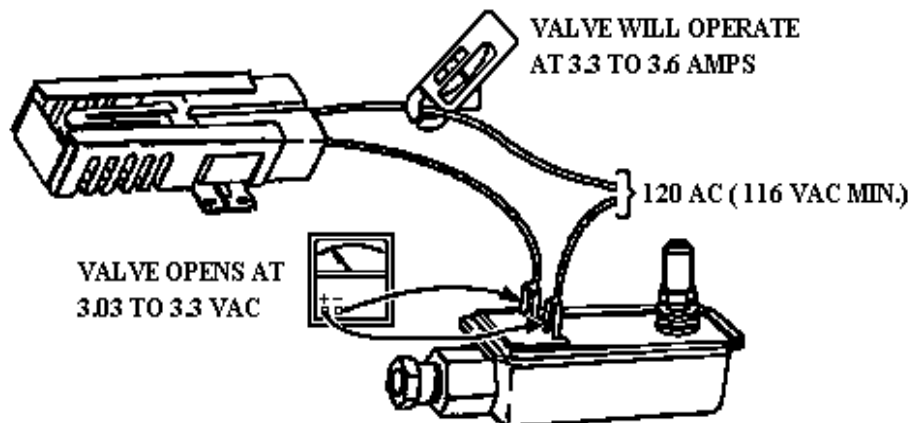

BAKE AND BROIL IGNITERS

The bake and broil igniters are mounted to the bake and broil burner and ignite the gas flowing into the burner. During a bake or broil operation, current flows through the igniter, gas valve and thermostat to neutral. As the igniter starts heating and glowing, its internal resistance decreases allowing more current to flow through the bake or broil circuit. When the circuit current reaches approximately 3.2 to 3.6 amps, the bi-metal arm in the gas valve flexes, opening the valve, allowing gas to flow to the burner when it is ignited by the glowing igniter. The igniter will glow anytime the bake or broil burners are in operation and cycle on and off with the thermostat cycling contacts.

The igniter can be checked for continuity by using an ohmmeter set to the Rx10 range. Remove the igniter from the burner and disconnect the igniter wiring. Attach one meter lead to each igniter wire. A resistance of several hundred ohms may be indicated and may vary with each igniter. The main purpose of this test is to see if the igniter is open internally. **The igniter may still be defective even though continuity is indicated and it glows when the oven is set for a bake, broil or clean function.** A more exact test is to measure the igniter current with the oven operating. An ammeter should be inserted in series with one lead of the igniter or any amprobe attached to the of the igniter will check the amount of current flowing through the igniter circuit.

With the oven turned on and the igniter glowing red, a current reading of approximately 3.2 to 3.6 amps should be indicated.

GAS VALVE

The bake and broil gas valves supply gas flow to the bake or broil burners. The valve contain a bi-metal arm attached to the valve seat and is wound with a small electric heater coil. When a current range of approximately 3.2 to 3.6 amps flows through the bake or broil circuit the bi-metal arm is heated causing it to flex or bend, allowing gas to flow to the burner where it is ignited by the burner igniter. An amperage reading less than 3.2 will cause the gas valve to partially open, resulting in a reduced gas flow to the burners.

A continuity test can be made to check the bi-metal arm heater by using an ohmmeter set to the low ohm range or a continuity tester. Access to the bake valve can be made by removing the access panel. The broil gas valve is located on the right side of the burner box flueway and the bake valve is located on the left side of the oven burner box. Power to the oven must be shut off and the gas valve wiring removed.

Attach the meter or tester leads to the two gas valve terminals facing the rear of the oven. A low ohms reading or continuity should be indicated. Repeat the same test on the two gas valve terminals facing the front of the oven . If infinite ohms or an open heater coil is indicated on either set of terminals the complete gas valve must be replaced.

DOOR REMOVAL

1. Open the door approximately 15* to 20* then slowly pull upward until the door stop (A) pops out of the door socket. Gently close the door until the door stops rest against one of the stop notches (C). Slide the door up until completely free of the hinge arms.

When the door stops pop out of the door too soon the door will not slide off. When this happens:

- a) Lower the door until the door stops disappear into the door;

- b) Grasp the door near the lower end;
- c) Place your thumbs over the door socket openings to prevent the door stops from popping out;
- d) Hold the door stops in the door while sliding the door up approximately inches;
- e) Release the door stops and gently close the door until the door stops rest against one of the stop notches.

2. To replace the door, place the hinge arms into the door sockets. Slide the door down close to the door stops and release the pressure from the stop notches. Slowly lower the door down completely allowing the door stops to retract into the door socket.

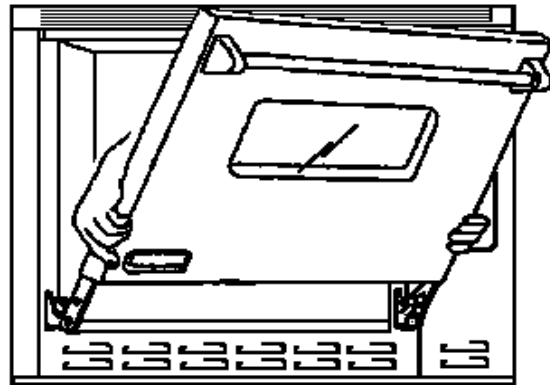
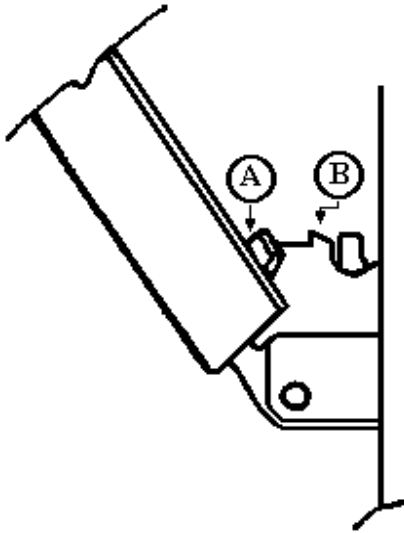

- A. DOOR (Vertical adjustment screw)
- B. DOOR STOP (Holds hinge in place while removing or replacing the door)
- C. DOOR HINGE SPRING (Color denotes part number)

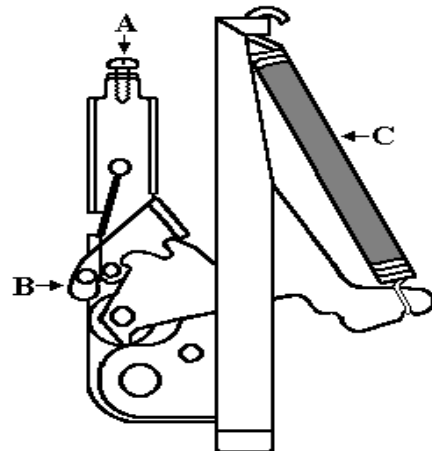

OVEN DOOR ASSEMBLY

1. Remove oven door and put on a protected table or counter top. (See oven door removal.)
2. Remove screws securing the door panel to the door liner and remove the panel from the liner.
3. Remove the inner baffle, the window trim and the glass window from the door panel.
4. The door handle is mounted to the door panel and can be removed by removing the four (4) screws.
5. Remove the insulation plate and insulation from the liner.
6. Remove the screws securing the window brackets to the door liner and remove the brackets.
7. Remove the door window retainer and remove window assembly.

3. Door handle is mounted to the door panel and can be removed by removing four (4) screws.
4. Remove the two (2) cap nuts securing the logo to the outer door panel.

DOOR HINGE REMOVAL

1. Remove door. (See oven door removal.)
2. Remove oven racks, rack supports, oven bottom and inner side wall.
3. Remove two (2) screws securing the hinge cover to the oven side wall.
4. Open the hinge and lock in the most open position.
5. Remove the lower and upper Phillips head screws (located behind the oven gasket) securing the hinge to the front frame.
6. Remove the hinge to the inside of the oven by pulling through the hinge slot.

HANDLE and LOGO REMOVAL

1. Remove door. (See door removal.)
2. Remove screws securing the door panel to the door liner and remove panel from the liner.

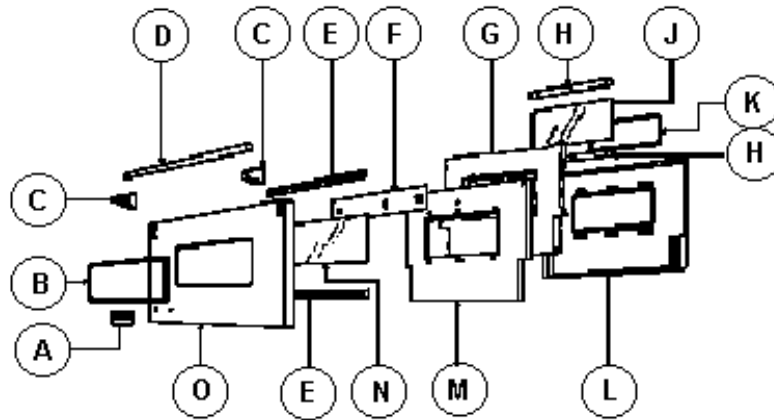

OVEN DOOR PARTS

- | | |
|-----------------------------------|---|
| A. Logo | K. Door Glass Seal |
| B. "J" molding | L. Inner Door Liner With Window |
| C. Door Handle Bracket | M. Insulation Retainer With Window |
| D. Door Handle | N. Outer Door Glass |
| E. Outer Door Glass Retainer | O. Outer Door Panel With Window |
| F. Heat Baffle | #. Upper Door Brace (Used on 36" models only) |
| G. Insulation (32 1/2" x 16 7/8") | #. Lower Door Brace (Used on 36" models only) |
| H. Inner Door Glass Retainer | |
| J. Inner Door Glass | |

CONTROL PANEL and LANDING LEDGE REMOVAL

CONTROL PANEL REMOVAL

1. Shut off power to the unit.
2. Remove all top burner and grill knobs.
3. Remove lower bezel screw from the second burner control from each end of the control panel. (Remove lower bezel screw from grill control on grill models.)
4. Remove two decorative screws at both ends of the control panel.
5. It is not necessary to remove bezels.

LANDING LEDGE REMOVAL

1. Shut off power to the unit.
2. remove the control panel. (See control panel removal.)
3. Remove grates, burner bowls and grate supports.
4. Remove griddle and grill grates and grate supports.
5. Remove the screws along the back of the landing ledge.
6. Remove the two (2) screws at each end of the front of the landing ledge.
7. Remove the landing ledge.

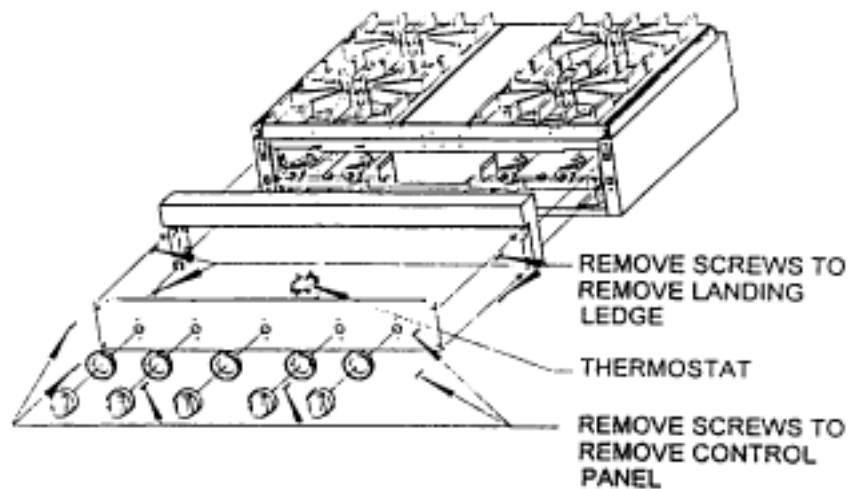

COMPONENT LOCATION

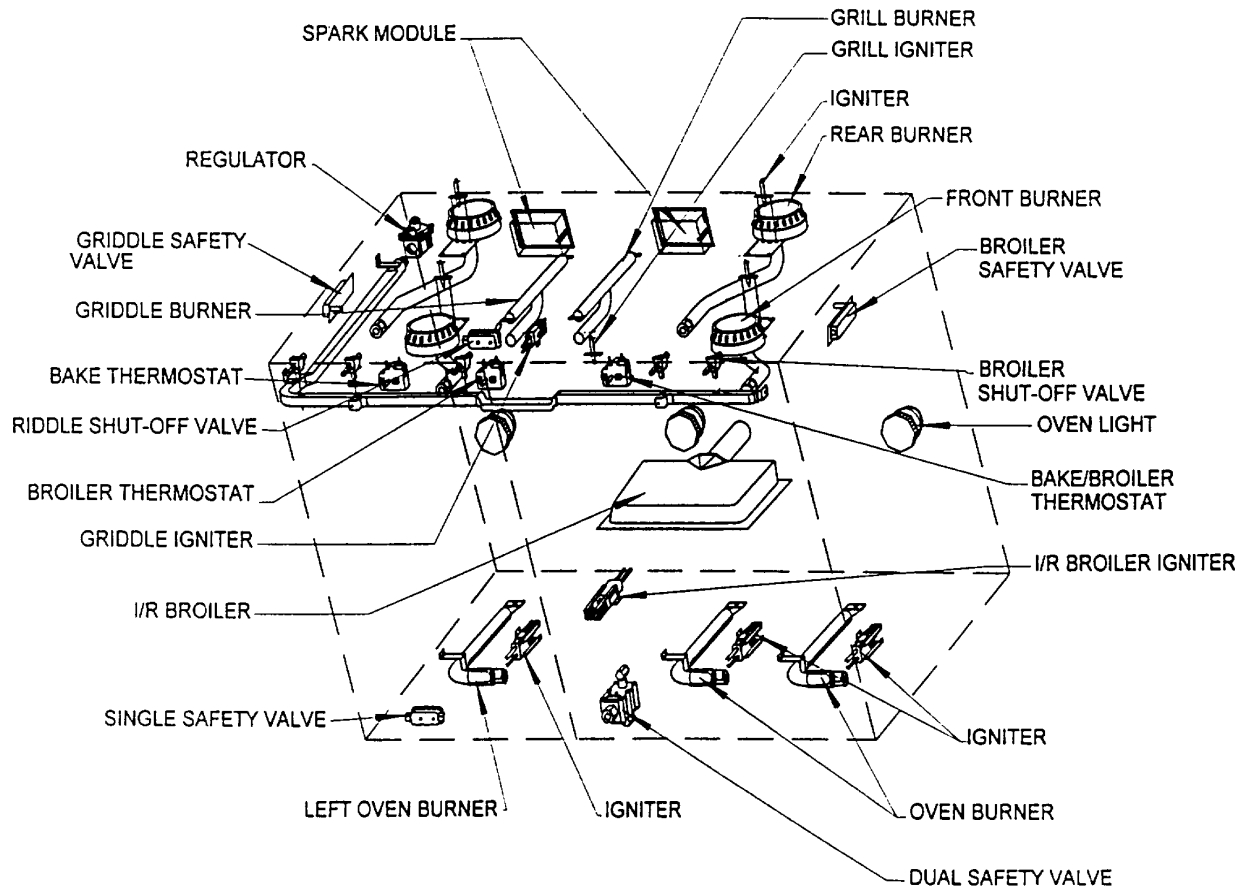

TOP BURNER REMOVAL

1. Shut off power to the oven.
2. Remove grates, burner bowls and grate supports.
3. Remove the phillip head screw near the burner head securing the burner to the burner support.
4. Lift the burner and venturi assembly and remove the wire from the bottom of the ignitor.
5. Both burner assemblies (front and rear) can be removed together by removing one (1) screw at the rear of the burner support, remove both ignitor wires and lift the burner support assembly.

TOP BURNER IGNITOR REMOVAL

1. Shut off power to the oven.
2. Remove grate and burner bowl.
3. Remove two (2) screws securing the ignitor to the burner support.
4. Disconnect the ignitor wire.

SPARK MODULE REMOVAL

NOTE: FOUR BURNER MODELS WITH OR WITHOUT A GRIDDLE USE ONLY ONE (1) SPARK MODULE; FOUR (4) BURNERS WITH A CHAR GRILL REQUIRES TWO (2) SPARK MODULES.

1. Remove left and right grates, burner bowls and grate supports.
2. Remove two (2) screws securing the spark module cover, using care not to damage wiring.
3. Disconnect the wiring. (When replacing module cover, do not forget to ground green wire to chassis.)
4. For wiring sequence see wiring schematic section.

BURNER BOX SECTION

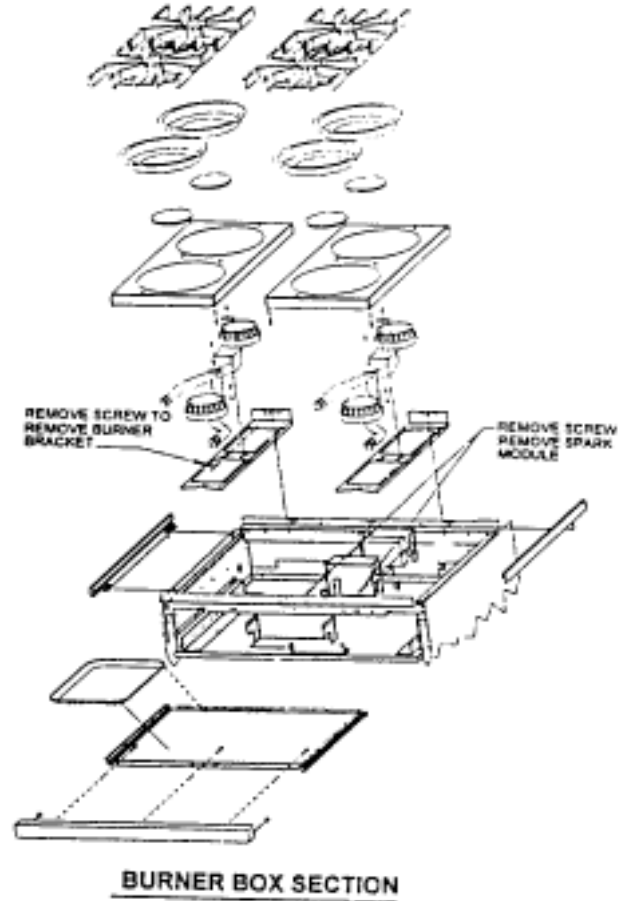

INDICATOR LIGHT REMOVAL

1. Shut off power to the unit.
2. Remove the control panel. (See control panel removal.)
3. Disconnect the wiring from the indicator light.
4. Push the indicator light out of the control panel.

BAKE/BROIL THERMOSTAT REMOVAL

1. Shut off power to the unit.
2. Remove the control panel. (See control panel removal.)
3. Remove the two (2) clips securing the thermostat bulb to the inner back wall.
4. Remove the left side grates, burner bowls and grate supports.
5. Carefully pull the capillary tube out of the oven cavity.
6. Disconnect the thermostat wiring one lead at a time and connect to the appropriate terminal on the replacement thermostat.
7. Remove two (2) screws mounting thermostat to the control panel.

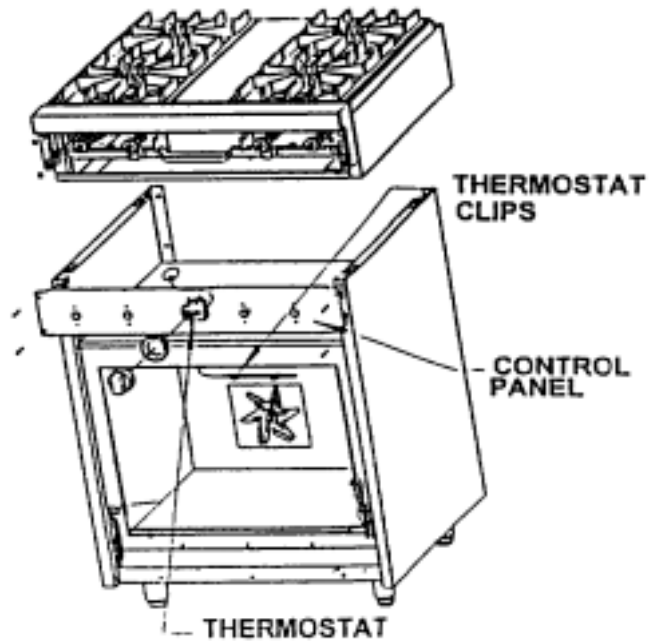

OVEN IGNITOR REMOVAL

1. Shut off power to the oven.
2. Remove oven door. (See oven door removal.)
3. Remove the lower access panel below the oven door by removing two (2) mounting screws on either side under the oven door hinges.
4. Disconnect the wire leads to the ignitor.
5. Remove the oven burner. (See oven burner removal.)
6. Remove two (2) screws securing the ignitor to the burner and remove the ignitor.

BROIL GAS VALVE REMOVAL

1. Shut off power to the oven.
2. Shut off gas supply to the oven.
3. Remove right side grates, burner bowls and grate supports.
4. Disconnect the wire leads to the broil valve connecting leads to replacement valve.
5. Disconnect the gas supply tubing from the gas valve.
6. Remove two (2) screws securing the gas valve to the mounting bracket.

BAKE/BROIL THERMOSTAT

NOTE: CHECK ALL CONNECTIONS FOR LEAKS USING A SOAP SOLUTION AFTER INSTALLING THE REPLACEMENT VALVE.

OVEN GAS VALVE REMOVAL

1. Shut off power to the oven.
2. Shut off gas supply to the oven.
3. Remove the oven door. (See oven door removal.)
4. Remove the lower access panel below the oven door by removing two (2) mounting screws on either side under the door hinges.
5. Disconnect the wires leads to the gas valve.
6. Disconnect the gas supply tubing to the gas valve.
7. Remove two (2) screws securing the gas valve to the mounting bracket.

NOTE: CHECK ALL CONNECTIONS FOR LEAKS USING A SOAP SOLUTION AFTER INSTALLING THE REPLACEMENT VALVE.

TOP BURNER VALVES

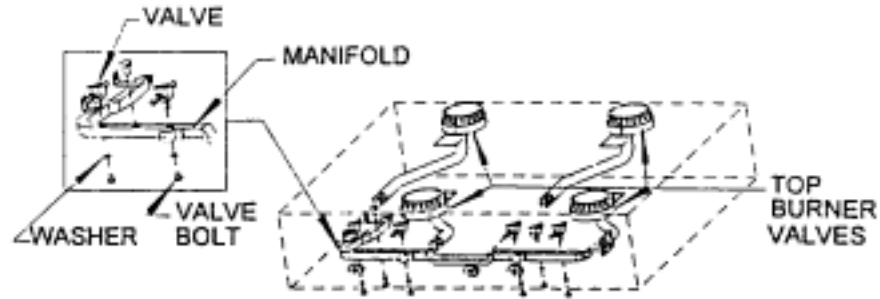

VALVE REPLACEMENT

1. Remove the control panel. (See control panel removal.)
2. Remove the lower valve blot and gasket.
3. Lift the valve from the manifold.

NOTE: CHECK ALL CONNECTIONS FOR LEAKS USING A SOAP SOLUTION AFTER INSTALLING THE REPLACEMENT VALVE.

PRESSURE REGULATOR REMOVAL

1. Shut off power to the oven.
2. Shut off gas supply to the oven.
3. Remove the left side grates, burner bowls and grate supports.
4. Disconnect the gas supply to the oven.
5. Remove the regulator with a pipe wrench turning counter clock wise. (Secure the manifold with another wrench before turning.)

NOTE: CHECK ALL CONNECTIONS FOR LEAKS USING A SOAP SOLUTION AFTER INSTALL REPLACEMENT REGULATOR. USE SEALANT ON ALL PIPE JOINTS. SEALANT MUST BE RESTIVE TO L.P. GAS. **DO NOT USE THREAD TAPE.**

CONVECTION FAN REMOVAL

1. Shut off power to the unit.
2. Remove the control panel. (See control panel removal.)
3. Disconnect the wiring from the fan switch.
4. Push the fan switch out of the control panel.

OVEN BURNER REMOVAL

1. Shut off power to the oven.
2. Remove the oven door. (See oven door removal.)
3. Remove the lower access panel below the oven door by removing two (2) mounting screws on either side under the oven door hinges.
4. Disconnect the ignitors.
5. Remove two (2) screws securing the oven burner.
6. Remove the oven burner pulling forward until the burner is free. (Be sure to align rear tab of the burner with the mounting bracket in the oven when replacing the burner.)

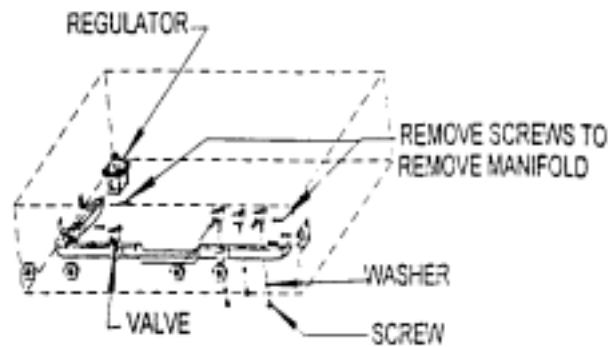

MANIFOLD & REGULATOR

INFRARED BURNE

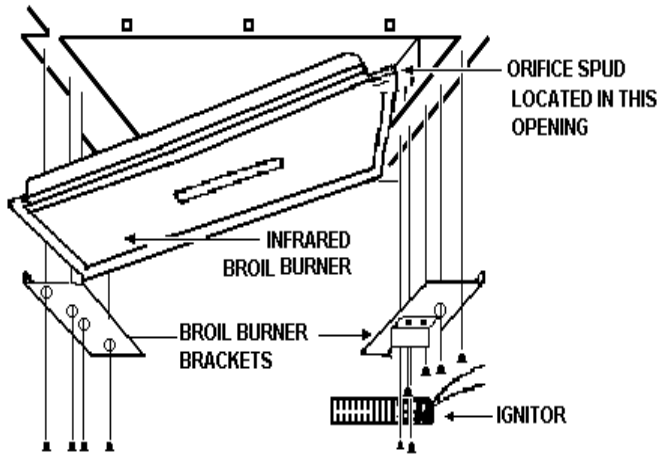

BROIL BURNER REMOVAL

1. Shut off power to the unit.
2. Shut off the gas supply.
3. Move the range out of the opening.
4. Disconnect the gas supply.
5. Remove the four (4) screws attaching the rear vent and remove the vent. (Backguard, high shelf or island trim.)
6. Remove the large pal nut securing the broiler to the supply tubing and the spud assembly.
7. Remove the oven door. (See oven door removal.)
8. Remove two (2) broil ignitor mounting screws and remove the ignitor from the broil burner.
9. Remove the broil burner mounting screws securing the burner to the oven cavity.
10. Remove the broil burner.

BROIL IGNITOR REMOVAL

1. Shut off power to the oven.
2. Remove the two (2) broil ignitor mounting screws and pull the ignitor leads into the oven cavity.
3. Disconnect the wire leads.

INDICATOR LIGHTS

There is an indicator light for each oven thermostat. The oven indicator light should be on during bake or broil operations. This light will cycle on and off with the thermostat cycling.

A voltage test can be made to check the indicator light operation. Access the indicator lights by removing the control panel. Attach the leads from a voltmeter set to

measure 120VAC or a test light to the indicator terminals and turn the oven on to bake operation. If voltage is present at the indicator terminals or the tester lights up, and the indicator does not light, replace the indicator.

OVEN LIGHT SWITCH

The oven light switches are mounted in the control panel. The light switch can be checked for continuity by using an ohmmeter set to the low ohms range or a continuity tester.

Access to the switch can be made by removing the control panel. Disconnect the wires from the switch. Attach the meter or tester leads to the switch terminals. Continuity or low ohms should be indicated when the switch contacts are closed and no continuity or infinite ohms indicated when the switch contacts are open. If the switch fails this test, it must be replaced.

OVEN LIGHT SWITCH REMOVAL

1. Shut off power to the unit.
2. Remove the control panel. (See control panel removal.)
3. Disconnect the wires from the switch.
4. Push the switch forward and out of the control panel.

OVEN GASKET REMOVAL

1. Remove the oven door. (See oven door removal.)
2. Open the hinge to the broil position.
3. Loosen the upper and lower phillips head screws (located behind the oven gasket) that secure the hinge to the front frame.
4. Pull the gasket from the frame.

CONVECTION FAN REMOVAL

1. Shut off power to the oven.
2. Remove the door. (See oven door removal.)
3. Remove the oven racks.
4. Remove the hex head screws securing the fan cover to the rear wall of the oven
5. Remove the hex head screws securing the fan mounting box to the rear wall of the oven, (being careful not to allow the motor wires to come loose and fall behind the rear wall of the oven) disconnect the wiring one lead at a time and

OVEN LIGHT REMOVAL

1. Shut off power to the oven.
2. Unscrew the light cover from the light socket.
3. Turn the light socket to the left 1/4 turn.
4. Pull the light socket forward and disconnect the wires one lead at a time and connect to the appropriate terminal on the replacement light socket.

GRILL BURNER REMOVAL

1. Remove the grill grates, grate supports, flame spreader and the burner shield.
2. Remove the screw at the front and rear of the burner.
3. Lift the burner off of the orifice and remove from the burner box.

GRIDDLE BURNER / IGNITOR REMOVAL

1. Shut off power to the oven.
2. Remove the grates, burner bowls, and grate supports on either side of the griddle. Lift and remove the griddle.

3. Remove two (2) screws securing the ignitor to the griddle box. Disconnect the wiring from the ignitor.
4. Remove four (4) screws securing the venturi cover and remove the cover.
5. Remove the burner tube from the griddle box.

GRIDDLE THERMOSTAT REMOVAL

1. Shut off power to the unit.
2. Remove the control panel. (See control panel removal.)
3. Remove the griddle plate. (See griddle removal.)
4. Remove the thermostat bulb from the clips in the griddle box.
5. Carefully pull the thermostat bulb from the opening in front of the griddle box.
6. Remove the thermostat knob.
7. Remove two (2) screws securing the thermostat to the control panel.
8. Remove the wire leads and connect to the replacement thermostat.

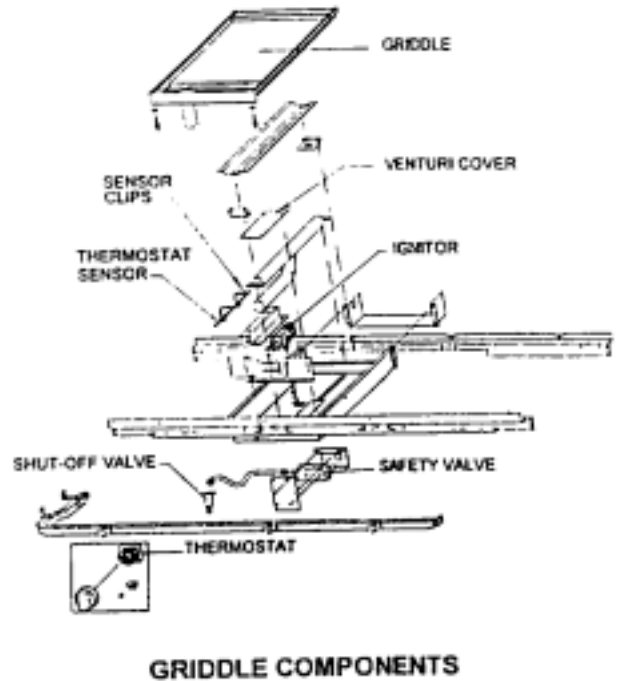
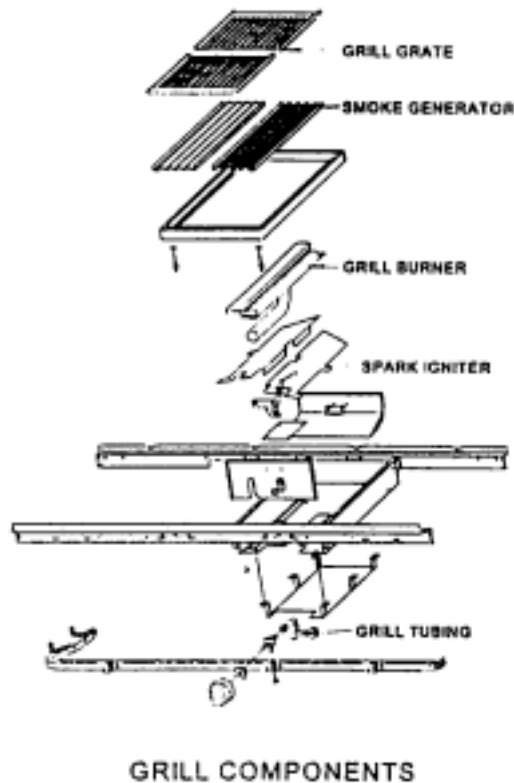

TROUBLE SHOOTING GUIDE		
PROBLEM	PROBABLE CAUSE	CORRECTION
1. No bake operation in bake or broil.	1A. No voltage to thermostat	1A. Check for 120VAC at the thermostat terminals BA to Neutral. If no voltage is present check for broken wiring. voltage is present check for broken wiring.
2. No bake operation. Broil operates normally, bake ignitor does not glow red.	2A. Defective thermostat contacts 2B. Defective Ignitor. 2C. Open heater coil in gas valve.	2 A. Check thermostat contacts for continuity or check for 120VAC at thermostat contact BA to Neutral. If no voltage is present or open contacts indicated, replace the thermostat. If voltage is present or contacts are closed, check for broken wiring between thermostat and ignitor. Proceed to 2B 2 B. Check ignitor for continuity. If no continuity is indicated or if ignitor does not glow when tested, replace the ignitor. If the ignitor glows when tested or indicates continuity, check for broken wiring between the ignitor and gas valve. Proceed to 2C. 2 C. Check gas valve heater coil for continuity If heater coil is open replace the gas valve If continuity is indicated, check for broken wiring between the gas valve and thermostat
3. No broil operation. Bake operates normally. Broil ignitor does not glow red.	3A. Defective thermostat contacts. 3B. Defective ignitor. 3C. Open heater	3 A. Check thermostat contacts for continuity or check for 120VAC at the thermostat contacts BR to Neutral. If no voltage is present or open contact is indicated, replace the thermostat. If voltage is present or the contact is closed, check for broken wiring between the thermostat and ignitor. 3 B. Check the ignitor for continuity, if no continuity is indicated or if the ignitor does not glow when tested, replace the ignitor. If the ignitor glows when tested or indicated continuity, check for broken wiring between the ignitor and gas valve. Proceed to 3C. 3 C. Check the gas valve heater coil for continuity If the heater coil is open, replace the gas valve. If continuity is indicated, check for broken wiring between the gas valve and thermostat.
4. No gas flow to the burner ignitor glows red. a) Intermittant burner flame b) lighting only one side of burner. c) gas odors d) lowering average temp. of oven.	4A. Defective ignitor 4B. Gas pressure too low	4 A. Check the ignitor current draw. If less than 3.2 amps, replace the ignitor. 4 B. Check for correct gas pressure, Nat. gas pressure should be 5" WCP and LP should be 10" WCP.

TROUBLE SHOOTING GUIDE		
PROBLEM	PROBABLE CAUSE	CORRECTION
5. Gas flows to bake/broil burner but does not light	5A. Ignitor position too far from burner. 5B. Dirt or grease in orifice. 5C. Insufficient gas pressure. 5D. Gas supply.	5A. Reposition ignitor closer to the bake/broil burner. 5B. Clean the orifice. 5C. Check for correct gas pressure . Pressure should be 5" WCP for natural gas or 10" WCP for LP gas. 5D. Check oven shut off valve located on the manifold.
6. Fan motor does not operate.	6A. No power to the fan motor. 6B. Defective fan motor winding or frozen motor shaft.	6A. Check for 120VAC supplied to the fan motor. If no voltage is present, check the selector switch for continuity and, check for broken wiring between the selector switch and fan motor. If voltage is present at the fan motor proceed to 6B. 6B. Check the motor winding for continuity. Check for a frozen motor shaft and check check for broken wiring between the motor and neutral terminal block.
7. Oven light does not operate.	7A. Burned out bulb. 7B. Defective light switch. 7C. Defective light socket.	7A. Replace bulb. 7B. Check light switch contacts for continuity. 7C. Check for 120VAC the light socket terminals. If voltage is present, replace the light socket. If no voltage is present, check for broken wiring between the light switch and light socket.
8. Oven light stays on.	8A. Defective light switch.	8A. Check light switch contacts for continuity Replace light switch.
9. Oven indicator light does not come on.	9A. No power to the indicator Light. 9B. Defective indicator light.	9A. Check for broken wiring between the Thermostat and indicator and from the indicator to the neutral terminal block. 9B. Check for 120VAC at the indicator terminal. If voltage is present, replace the indicator light.
10. No spark at top burners.	10A. No power. 10B. Broken innitor. 10C. Wire connection. Pinched wire. 10D. Valve switch 10E. Defective spark module.	10A. Check power source. 10B. Replace spark electrode. 10C. Check connection between spark electrode and spark module. 10D. Check continuity on valve switch. If no continuity replace switch. If continuity checks ok, check all wire connections. 10E. Replace spark module.
11. Delayed ignition on top burner.	11A. Electrode position. 11B. Clogged ports on burner.	11A. Align electrode with burner port. 11B. Clean or replace burner.

TROUBLE SHOOTING GUIDE		
PROBLEM	PROBABLE CAUSE	CORRECTION
12. Intermittent spark or ghost spark (Ghost spark occurs when the ignition system is in the off position at approximately every 20 minutes).	12A. Lack of or improper ground.	12A. Check ground at outlet. Check module ground.
13. Continued reignition on top burner.	13A. Defective spark switch or incorrect switch. 13B. Position of spark electrode 13C. Lack of or improper ground. 13D. Defective spark module.	13A. Replace switch. 13B. Align spark electrode with burner port. 13C. Check ground outlet. Check ground at the module. 13D. Replace spark module.
14. Yellow tipping - produces soot and blocks flueways.	14A. Lack of primary air due to incorrect air shutter adjustment 14B. Blocked, dirty primary air openings or blocked burner ports. 14C. An orifice hood out of line will reduce primary air injection. 14D. Faulty drilling or a dirty orifice.	14A. Open air shutter to get rid of the yellow tips. CAUTION-too much primary air will cause lifting, noisy flames. Balance must be obtained. 14B. Clean and readjust burner 14C. Align with burner venturi and lube 14D. Clean orifice or replace faulty drilled orifice.
15. Lifting flames- flames rise from the ports to burn some distance above the port, also known as a noisy flame.	15A. Lifting burner flames results when the flow velocity of air-gas mixture from a port exceeds the flame velocity. (Flame Velocity -the speed at which a flame moves through a fuel/air Mixture.)	15A. Reduce primary air.
16. Fluctuating flame	16A. Normally caused by non Uniform gas pressure.	16A. Check gas pressure a) supply b) regulator 16B. Check orifice for blockage. a) metal shavings b) dirt or dust c) excess grease from burner valve.
17. Floating flame-lazy looking, no well defined inner cone, appears to be "reaching" for air. Normally a strong aldehyde odor is present. (Aldehyde-A class of compounds which have a pungent, distinct odor.)	17A. Lack of secondary air. combustion products recirculated in the burner box contaminate the air supply. 17B. The appliance may be over-rated. If so the flue outlet area may be too small for the gas rate.	17A. Open secondary air inlets. 17B. a) Decrease gas flow rate b) check and clear any blockage found in the flueway. c) check for blockage of burners And clean if necessary. d) Adjust primary air to get rid of any yellow tipping which may have produced soot to block the

TROUBLE SHOOTING GUIDE

PROBLEM	PROBABLE CAUSE	CORRECTION
18. Flashback-The air/gas mixture burn near the orifice, creating a roaring noise like a blow torch.	18A. Under rated burner ignites inside the burner to 18B. Increase primary air. 18C. Flashback occurs with the Burner valve in on off position, the valve is probably leaking.	18A. Check orifice size. Increase size if Necessary or increase gas pressure 18B. Adjust air shutter to reduce primary air. 18C. Change burner valve. 18D. If #1,2 &3 corrections fail to eliminate flash back, replace the burner.
19. Extinction pop-A small explosion of gas in the burner head occurs when the burner is shut off.	19A. Similar to flashback.	19A. Reduce primary air supplied to the burner. CAUTION: do not allow yellow tipping during burner operation. 19B. Check orifice size. 19C. Check gas pressure.



Check the gas supply and set the regulator to the proper supply of gas. A properly adjusted burner should be stable

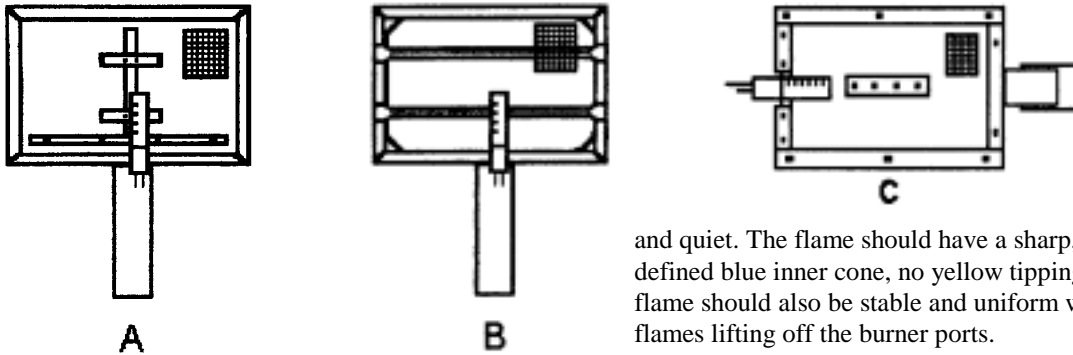

and quiet. The flame should have a sharp, well defined blue inner cone, no yellow tipping. The flame should also be stable and uniform with no flames lifting off the burner ports.

A. VGRC / VGSCI / R broiler construction prior to Feb. 1995 used one (1) screen support. The support was mounted internally from the venturi forward to the front of the broiler burner box. The screen support partially covered the glow coil ignitor. This usually caused slow or delayed ignition, especially when used LP gas.

B. A change in the manufacturing of the I / R Broiler repositioned the screen supports. The screen supports, now two (2), are positioned from, right to left. The glow coil ignitor is now completely open for igniting the gas almost immediately.

C. The first generation, VGR / VCM, screen support should be welded in four (4) places.

GRIDDLE REPAIR KIT

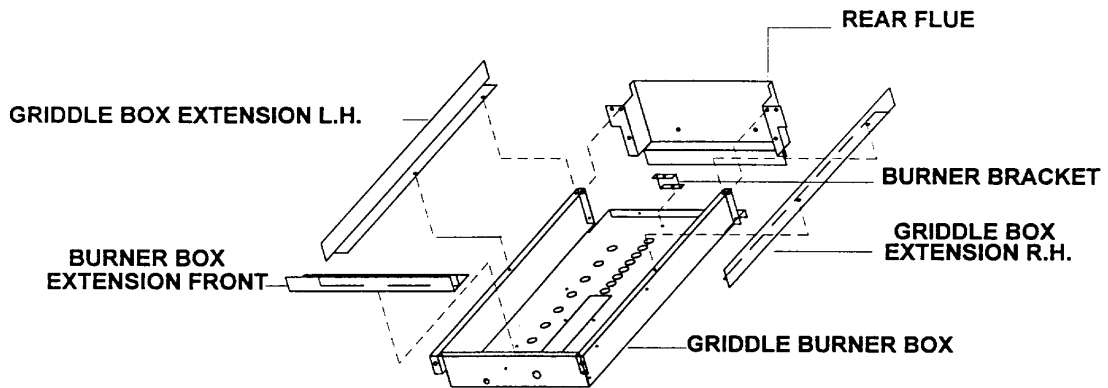

G3203168

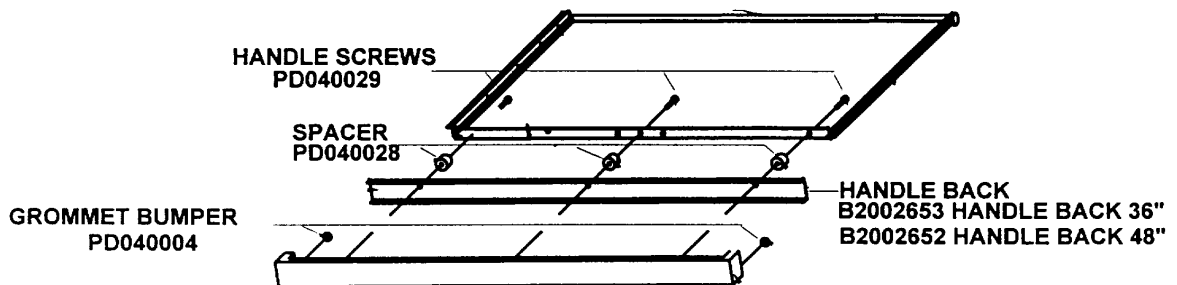

DRIP TRAY HANDLE
G3002582 DRIP TRAY HANDLE SS 36"
G9302583BR DRIP TRAY HANDLE BRASS 36"
G3002580 DRIP TRAY HANDLE SS 48"
G9302581BR DRIP TRAY HANDLE BRASS 48"

****GRIDDLE REPAIR KIT FOR 12" VIKING RANGETOP ONLY**

GRIDDLE REPAIR KIT 24" GRIDDLE

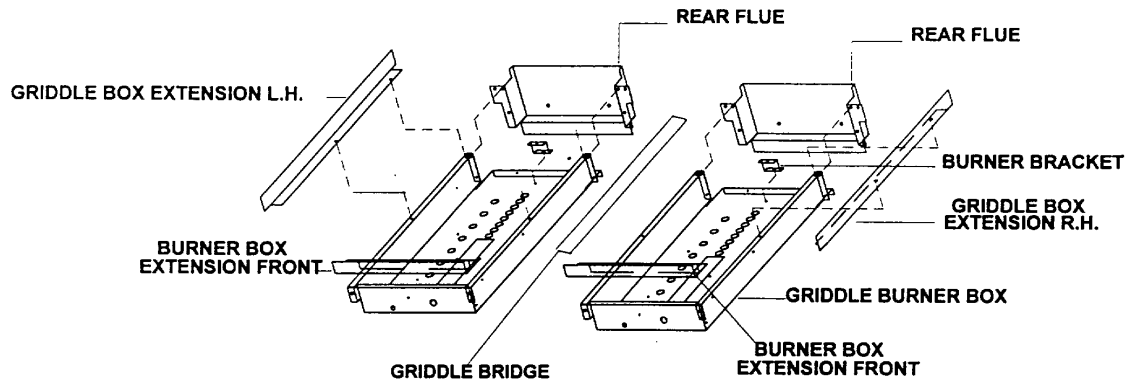

G3203149 24" GRIDDLE KIT

1. Attach griddle burner box to front burner support.
2. Install rear flue behind rear burner support. Attach rear flue to griddle burner box.
3. Connect front heat baffle to burner box.
4. Install rear burner bracket in burner box.
5. Place burner front into heat baffle mounting burner to rear burner bracket. Position venturi cover in burner box mounting with four screws.
6. Mount igniter to burner box connecting wires to thermostat and wiring harness.
7. Install thermostat bulb shield to bottom of burner box. Insert thermostat bulb into clips.
8. Mount left hand Griddle box extension to burner box.
9. Mount right hand Griddle box extension to burner box.
10. Mount center bridge between two griddle boxes securing with screws.
11. Slide burner box front extension into front top portion of burner box and front burner support.
12. Replace griddle with side extensions inside griddle. Front and rear tabs on griddle must be adjusted for griddle positioning.
13. Install Control panel and burner knobs.
14. With a proper flame height, adjust the air shutter to obtain a blue flame (with no yellow tipping) that sits on the burner at the burner ports.
 - a) Open the air shutter gap to eliminate yellow tipping.
 - b) Close the air shutter gap to prevent a noisy flame that lifts off the burner ports.
15. Replace grate supports, burner caps, burner bowls and grates.
16. Preheat griddle to 350 degrees. Check top burner ignition, burner flame for sharp blue innercone (no yellow tipping or lifting).

****GRIDDLE REPAIR KIT FOR 24" VIKING RANGETOP ONLY**

WIRING DIAGRAM

GAS - 30"W.\36"W.\48"W.\60"W.

RANGETOPS

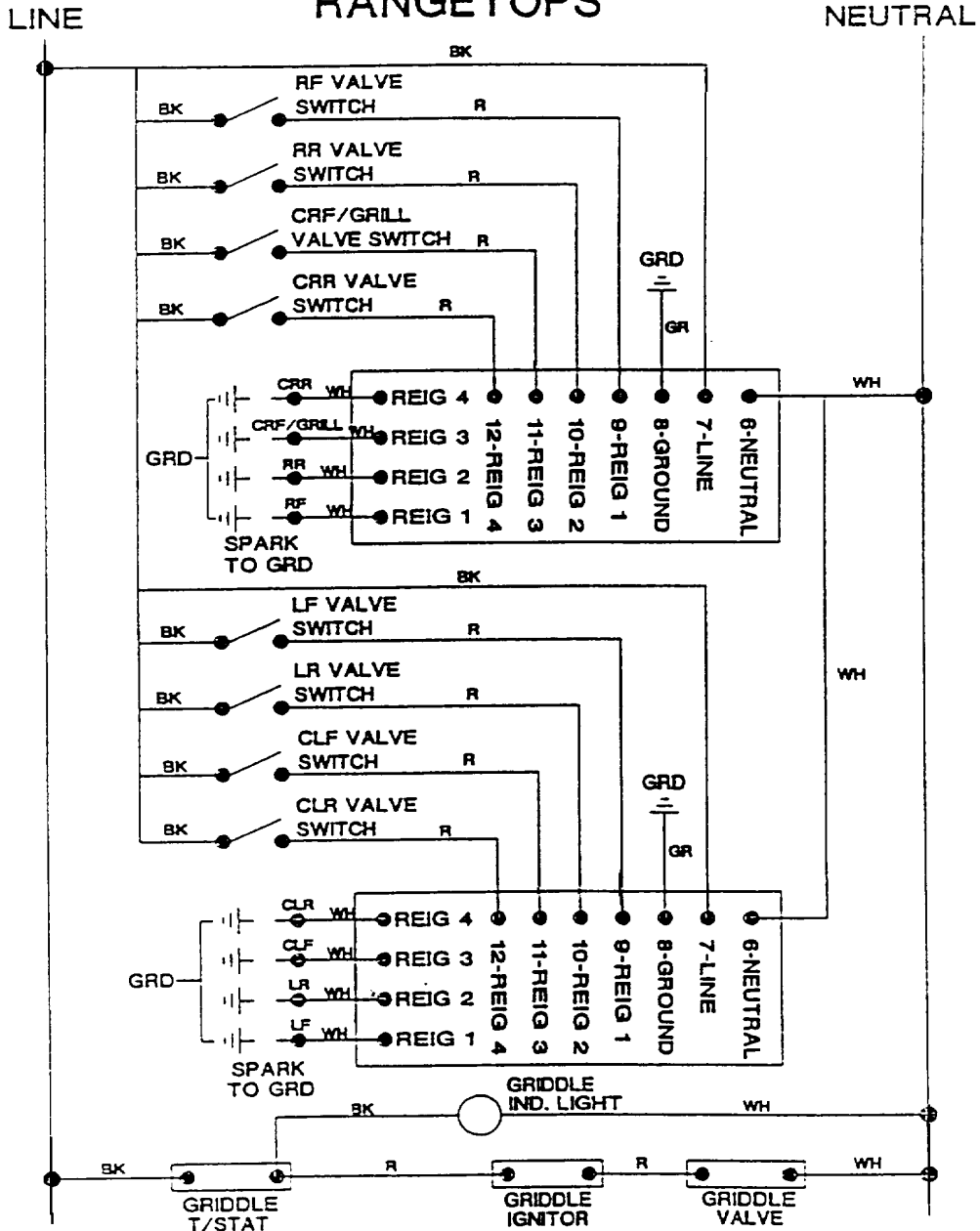

WARNING—ELECTRICAL GROUNDING INSTRUCTIONS
 THIS APPLIANCE IS EQUIPPED WITH A THREE PRONG
 GROUNDING PLUG FOR YOUR PROTECTION AGAINST SHOCK
 HAZARD AND SHOULD BE PLUGGED DIRECTLY INTO A PROPERLY
 GROUNDED THREE PRONG RECEPTACLE. DO NOT CUT OR
 REMOVE THE GROUNDING PRONG FROM THIS PLUG.

REFER ONLY TO FEATURES WHICH ARE
 EQUIPPED WITH THIS UNIT.

PF030218

WIRING DIAGRAM

GAS 36"W./48"W./60"W. CONVECTION RANGES

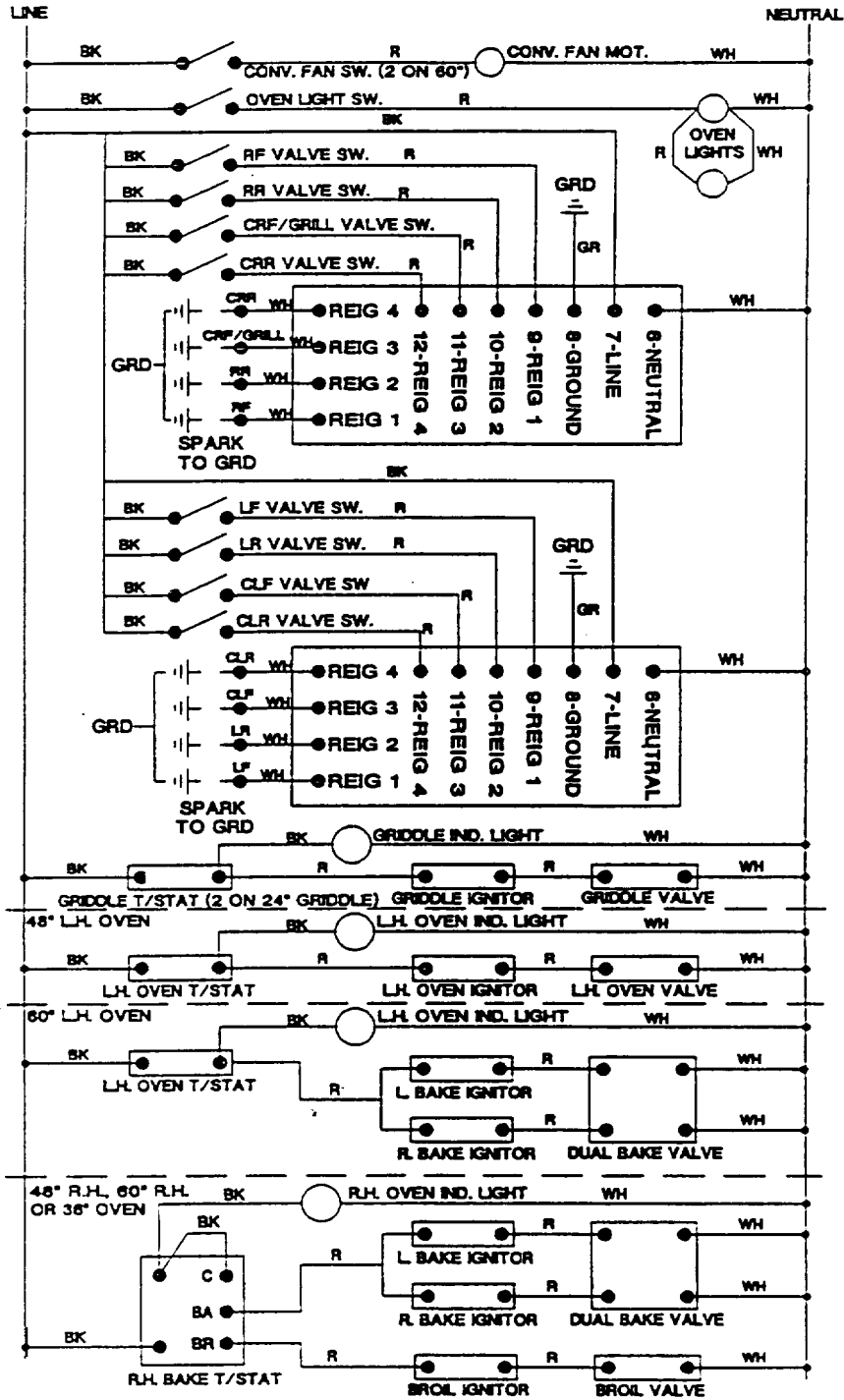

WARNING—ELECTRICAL GROUNDING INSTRUCTIONS
 THIS APPLIANCE IS EQUIPPED WITH A THREE PRONG
 GROUNDING PLUG FOR YOUR PROTECTION AGAINST SHOCK
 HAZARD AND SHOULD BE PLUGGED DIRECTLY INTO A PROPERLY
 GROUNDING THREE PRONG RECEPTACLE. DO NOT CUT OR
 REMOVE THE GROUNDING PRONG FROM THIS PLUG.

REFER ONLY TO FEATURES WHICH ARE
 EQUIPPED WITH THIS UNIT.

PF030170

Filename: GASRAN38.doc
Directory: D:\VBCODE\IPLUTILS\PDFGenerator\InputData\F90553 Free Standing Gas Ranges
Template: C:\Documents and Settings\tomw.EYECOM\Application Data\Microsoft\Templates\Normal.dot
Title:
Subject:
Author: Viking Range
Keywords:
Comments:
Creation Date: 7/9/2001 6:19 PM
Change Number: 3
Last Saved On: 3/28/2003 3:40 PM
Last Saved By: Ken Sievert
Total Editing Time: 1 Minute
Last Printed On: 3/28/2003 5:45 PM
As of Last Complete Printing
Number of Pages: 2
Number of Words: 5 (approx.)
Number of Characters: 29 (approx.)