

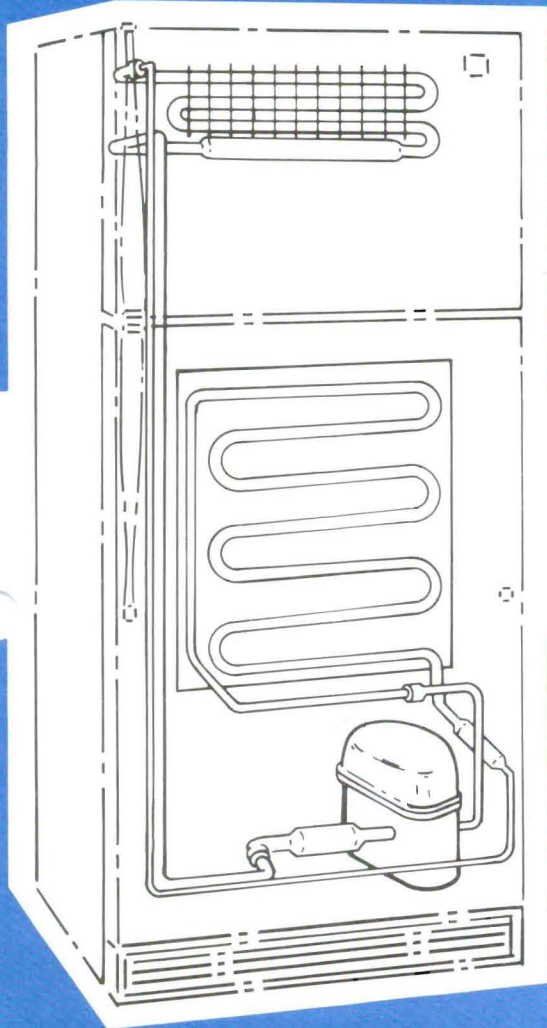

# CONSUMER SERVICES TECHNICAL EDUCATION GROUP PRESENTS

R-65



## BASIC REFRIGERATION DIAGNOSIS

Part No. 4314066B

ctors, Room Air Conditioners, Dehumidifiers, Automatic Washers, Clothes Dryers, Freezers, Refrigerator-Freezers, Ice Makers, Dishwashers, Built-In Ovens and Sur

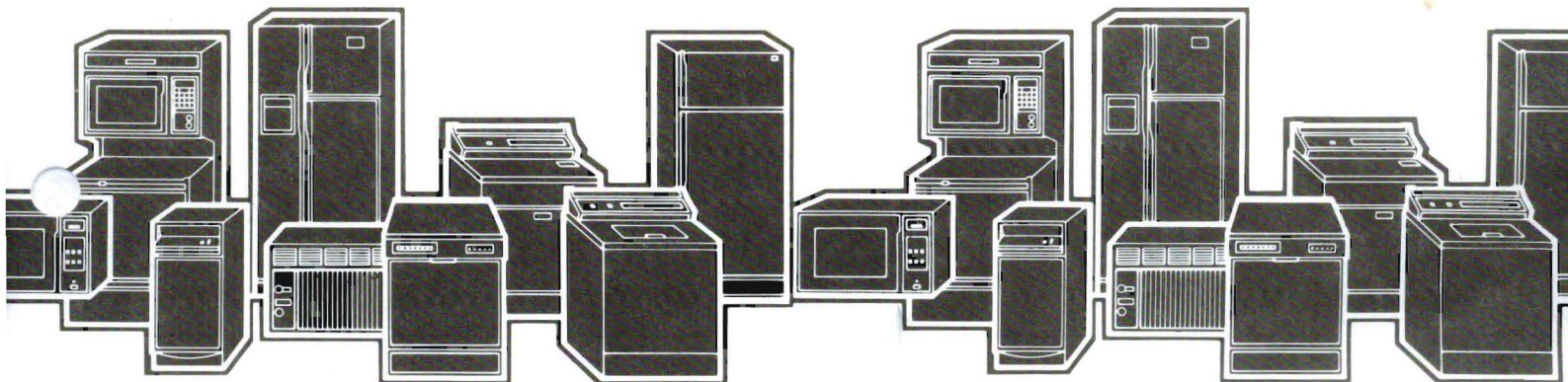

## CONTENTS

Section 1	The rules .....	1
Section 2	Building a refrigerator .....	9
Section 3	Additional components .....	20
Section 4	Wiring diagram .....	24
Section 5	Sealed system diagnosis .....	39

## **INTRODUCTION**

The purpose of this workbook is to provide support to the Sealed System Diagnosis video part number 4314079A. the workbook also provides you, the technician, with a basic understanding of refrigeration and provides the knowledge to properly diagnose the most common failure which occur in the refrigerator's sealed system.

This workbook has been revised to conform to the most current requirements of the Federal Government's Clean Air Act of 1992. Any previous version of this workbook should not be used.

## Section 1" Introduction to the Rules

Diagnosing problems with refrigerators is more difficult than it is with other appliances because of the number of things that can fail. The most common failures in refrigerators are in the basic electrical and mechanical systems. Simple things like door alignment, torn door gaskets, or electrical component failures cause most problems.

Before diagnosing a sealed system failure it is important to isolate the sealed system from other component failures which display similar symptoms.



Customer use problems are also common. If the customer left the door open for long periods of time, especially on hot, humid days, they will experience condensation problems with their refrigerator even though it is working properly.

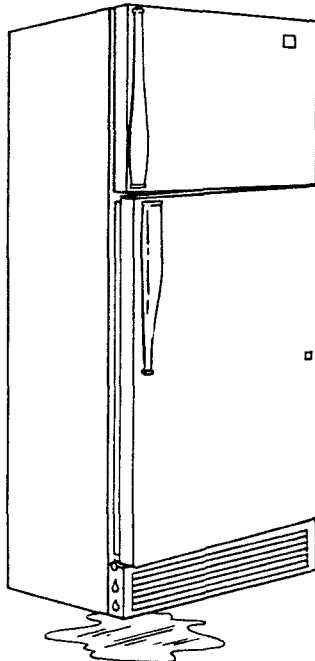

Even the environment can effect the refrigerator's performance. If the refrigerator is located in a room that is too hot it will not work properly.

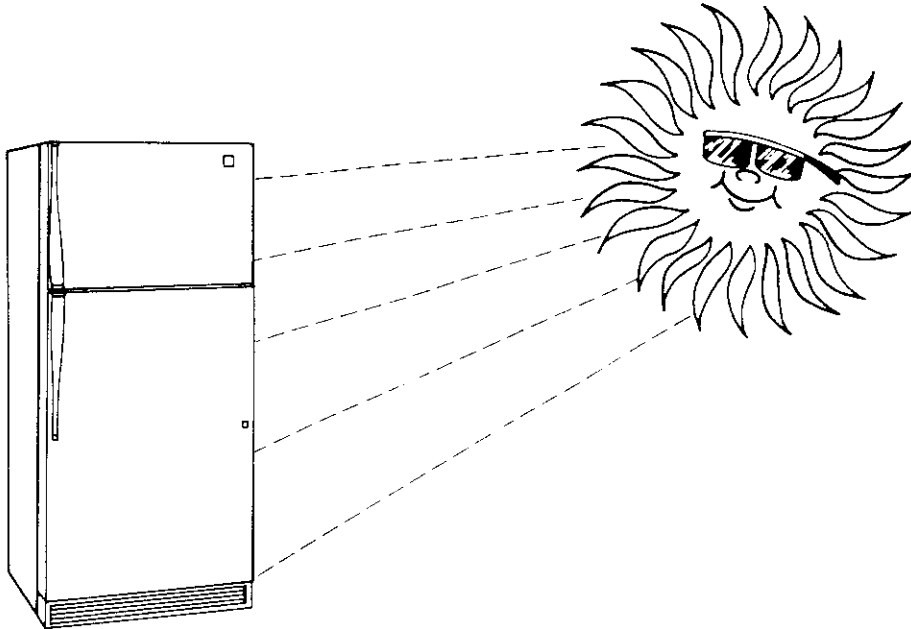

To effectively make a correct diagnosis on these types of problems and on sealed systems problems it is necessary to understand how the refrigerator works when it is working properly. In order to accomplish this we must have a good understanding of refrigeration basics. Without getting into a detailed discussion of physics let's try to understand the basic operation of a refrigerator.

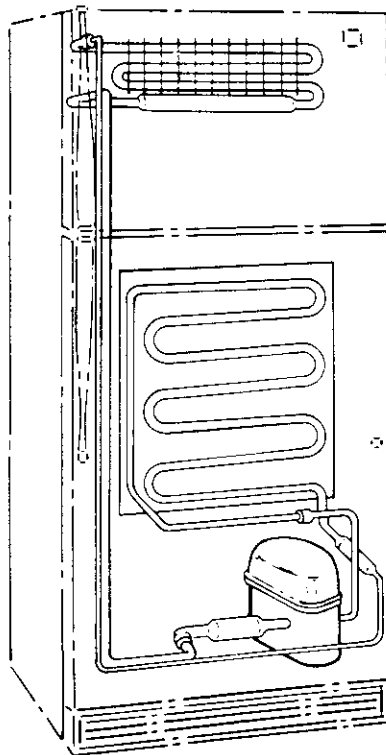



Refrigeration is the removal of heat from where it is not wanted....in the food....to an area where it can be easily dispersed....like outside the refrigerator.

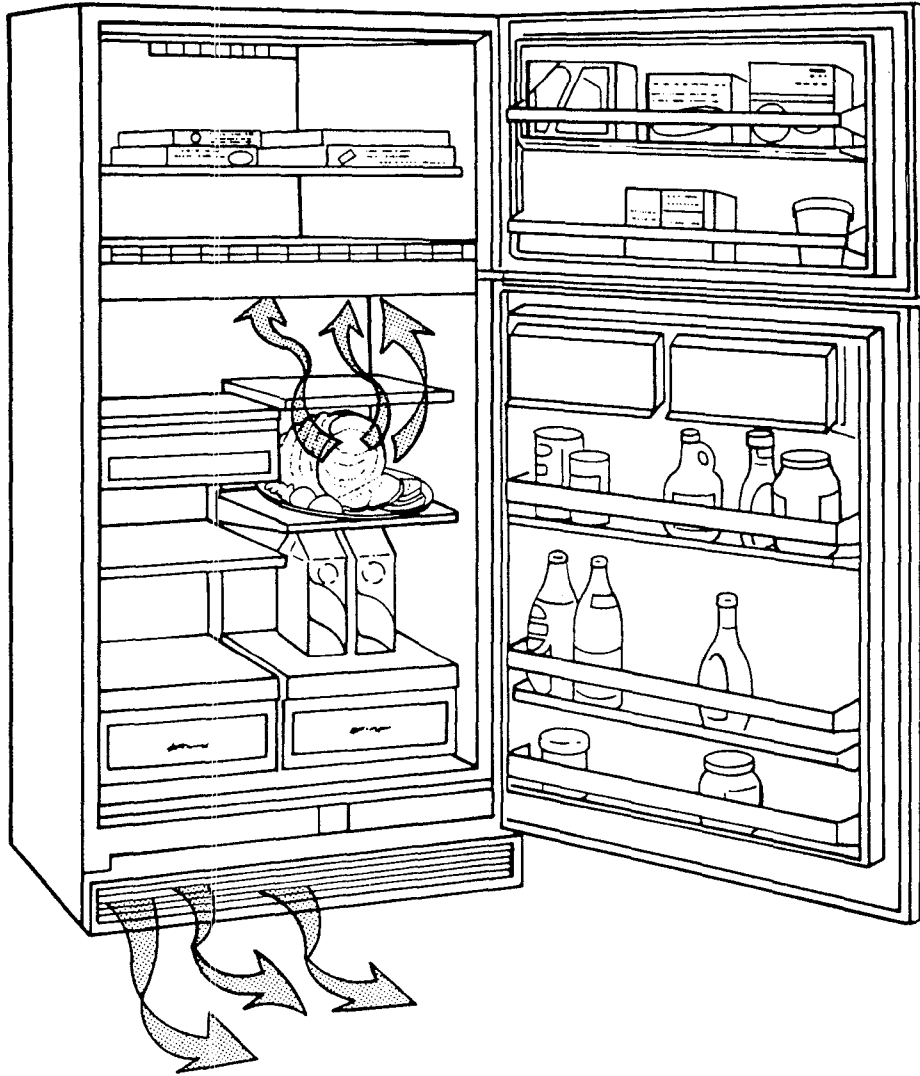

## 4 EASY RULES

### Rule 1

Cold is merely the absence of heat. A thermometer measures the amount of heat in an environment. As the heat is removed the temperature goes down.

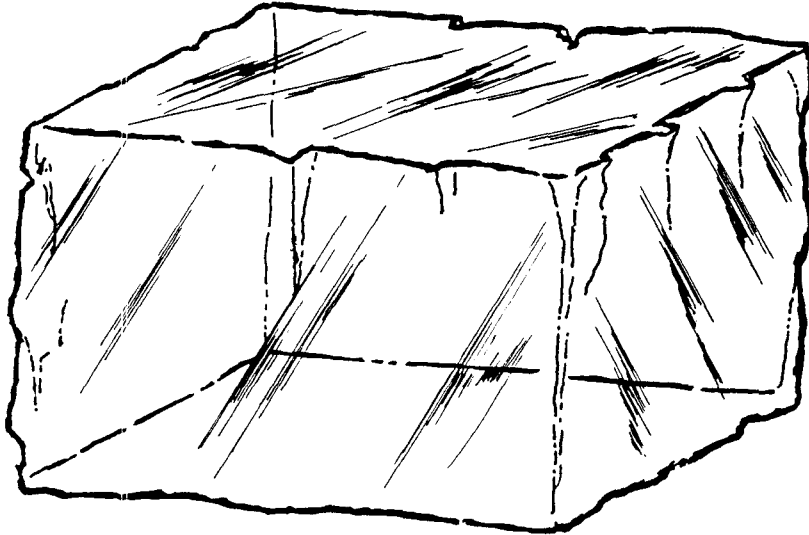

### Rule 2

The second rule to remember is heat will always radiate out or flow from a hotter area to a colder area.



**HEAT ALWAYS FLOWS FROM HOT TO COLD.**

### Rule 3

Higher pressure will produce higher temperatures.

Lowering pressure will reduce the boiling point of liquid.

With pressure reduced water will boil at 75°F.

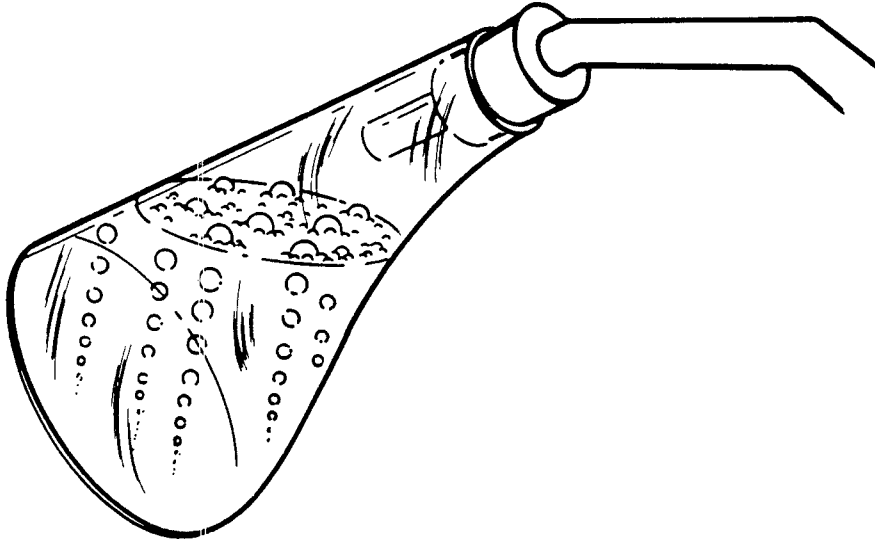

### Rule 4

When a liquid changes to a vapor it can absorb more heat than if it had remained a liquid.

Definition of terms used in this rule.

Heat is measured in **British thermal units** (BTU's).

One "BTU" equals the amount of heat generated by burning one kitchen match.

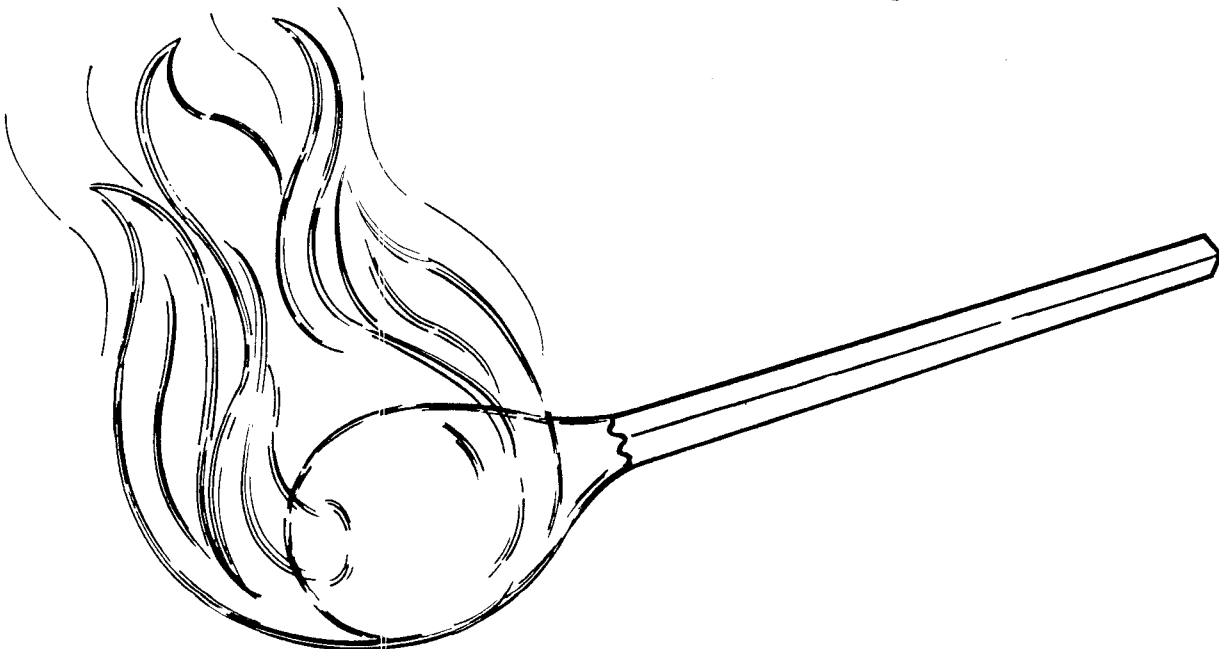

**Sensible heat** transfer is when temperature changes. This is illustrated on the chart between points A-B, C-D, and E-F.

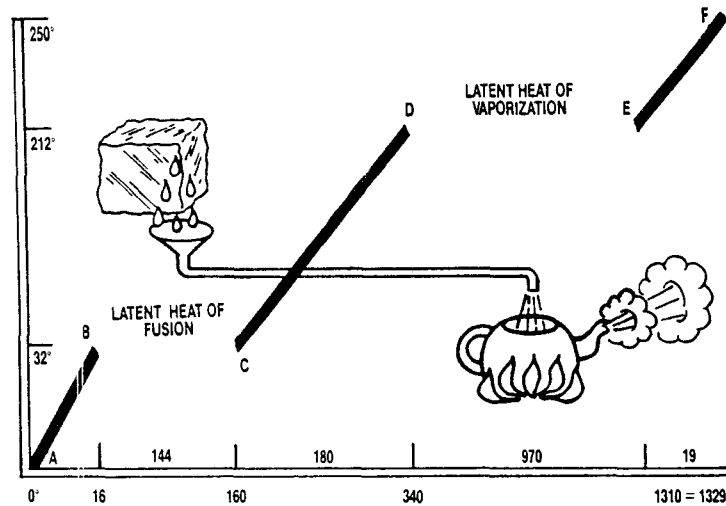

**A GRAPH OF THE AMOUNT OF HEAT UNITS REQUIRED TO CHANGE ONE POUND OF ICE AT 0°F TO STEAM AT 212°F.**

A TO B—TO HEAT ICE FROM 0° TO 32°	16 BTU
B TO C—TO MELT ICE 32° TO 32° WATER	144 BTU
C TO D—TO HEAT WATER FROM 32° TO 212°	180 BTU
D TO E—TO CHANGE WATER TO STEAM 212°	970.4 BTU
E TO F—TO HEAT STEAM TO DESIRED °F	
<b>TOTAL HEAT REQUIRED</b>	<b>1310.4 BTU</b>

**Latent heat** transfer is when the state of a substance is changed without a change in temperature. Such as ice to water or water to steam as illustrated on the chart between B-C and D-E.

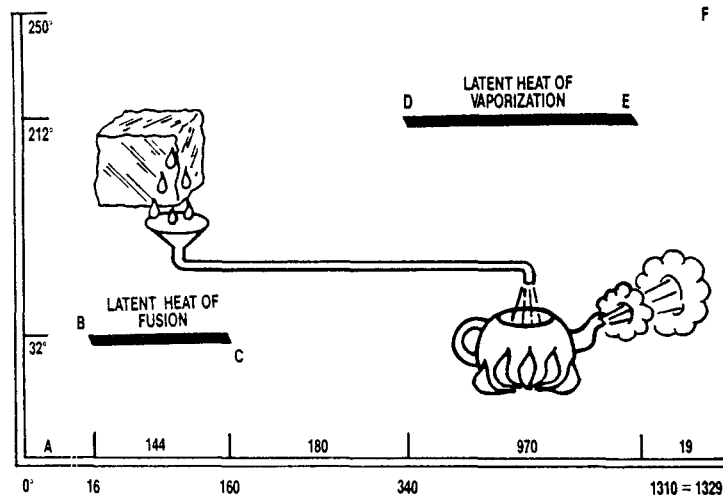

**A GRAPH OF THE AMOUNT OF HEAT UNITS REQUIRED TO CHANGE ONE POUND OF ICE AT 0°F TO STEAM AT 212°F.**

A TO B—TO HEAT ICE FROM 0° TO 32°	16 BTU
B TO C—TO MELT ICE 32° TO 32° WATER	144 BTU
C TO D—TO HEAT WATER FROM 32° TO 212°	180 BTU
D TO E—TO CHANGE WATER TO STEAM 212°	970.4 BTU
E TO F—TO HEAT STEAM TO DESIRED °F	
<b>TOTAL HEAT REQUIRED</b>	<b>1310.4 BTU</b>



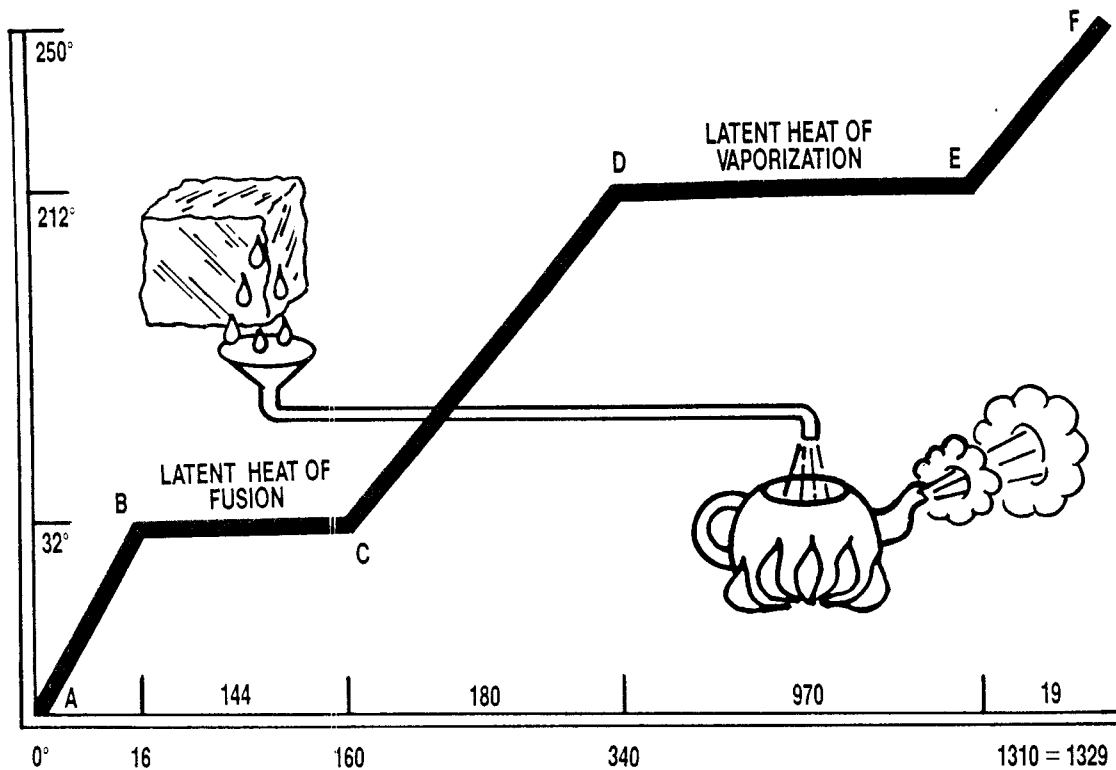

**A GRAPH OF THE AMOUNT OF HEAT UNITS REQUIRED TO CHANGE ONE POUND OF ICE AT 0°F TO STEAM AT 212°F.**

A TO B—TO HEAT ICE FROM 0° TO 32°	16 BTU
B TO C—TO MELT ICE 32° TO 32° WATER	144 BTU
C TO D—TO HEAT WATER FROM 32° TO 212°	180 BTU
D TO E—TO CHANGE WATER TO STEAM 212°	970.4 BTU
E TO F—TO HEAT STEAM TO DESIRED °F	19
<b>TOTAL HEAT REQUIRED</b>	<b>1310.4 BTU</b>

## **EFFECTS OF LATENT AND SENSIBLE HEAT**

It takes about 16 BTU's ...(approximately sixteen kitchen matches) ...of heat to raise the temperature of ice from 0°F to 32°F.

It will take about 144 BTU's to change the 32 degree ice to 32 degree water.

To summarize this rule.... it requires much more heat to change state..... (**latent** heat).... than it does to change temperature.... (**sensible** heat).

This is important in the refrigeration process because if we want to remove heat from the food in the refrigerator, we can remove more heat through latent heat transfer than with sensible heat transfer.

Review exercise "FOUR BASIC RULES OF REFRIGERATION".

1. Which of the following cause problems that look like sealed system problems:
  - A. Door alignment
  - B. Air flow
  - C. Customer use
  - D. A and C
  - E. A, B, and c
  
2. Cold is the lack of heat.
  - A. True
  - B. False
  
3. Cold always flows to a warmer area.
  - A. True
  - B. False
  
4. By lowering the pressure of water it can boil at 75 degrees.
  - A. True
  - B. False
  
5. When temperature changes degrees but not state it is called:
  - A. Latent heat
  - B. Sensible heat
  - C. B.T.U.'s
  
6. More heat is removed through Latent heat transfer than through Sensible heat transfer.
  - A. True
  - B. False
  
7. Sealed system failures are the most common of refrigerator failures.
  - A. True
  - B. False
  
8. Refrigerators;
  - A. Put cold into food.
  - B. Remove heat from food.

## "Section 2" Building a Basic Refrigerator

Now let's take these rules and see how they apply to our refrigerator.

According to **Rule one**, the reason we put our food in the refrigerator is because we want the refrigerator to remove the heat from it. This helps to preserve the food.

Heat removal is accomplished by the refrigerator's sealed system absorbing the heat in the food.... since heat flows from hot to cold, as we stated in **Rule 2**....., we need a substance in the refrigerator that can absorb a great deal of heat.

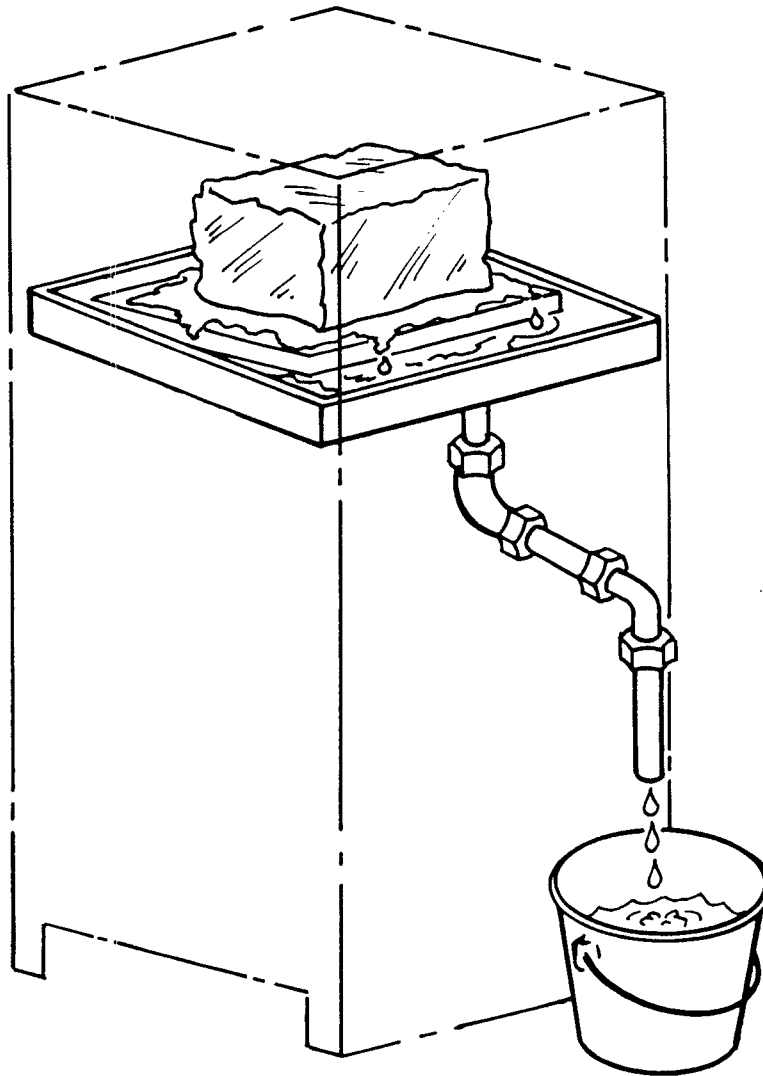

A few years ago food's heat was absorbed by ice.... this turned the ice into water.... the water would drain into a bucket outside of the ice box taking the heat from the inside with it.... this is how heat was removed from the food.

The modern day refrigerator uses the same principle as the ice box, but uses a refrigerant instead of ice. Refrigerants are liquids that boil or vaporize at very low temperatures. The refrigerant is converted from liquid to vapor inside the refrigerator's sealed system. This causes a great amount of heat to be absorbed from the food inside of the refrigerator.

Since the early 1990's R-134a has become the most common refrigerant used in residential refrigerators and freezers. This non-CFC refrigerant ( $\text{CF}_3\text{CH}_2\text{F}$ ) is environmentally friendly and has replaced R-12 which has been found to be detrimental to the earth's ozone layer. R-134a has a boiling point of  $-15.7^\circ\text{F}$ .

HEALTH AND SAFETY HANDLING	R134a
Allowable Overall Exposure Limit	1,000 ppm
Vapor Exposure to Skin	No effect
Liquid Exposure to Skin	Can cause frostbite
Vapor Exposure to Eyes	Very slight irritation
Liquid Exposure to Eyes	Can cause frostbite
Above Minimum Exposure Limit	Can cause asphyxiation, tachycardia and cardiac arrhythmias.
Safety and Handling	Wear appropriate skin and eye protection. Use adequate ventilation.
Spill Management	Remove or Extinguish Ignition or Combustible Sources. Evacuate or Ventilate Area.
Fire and Explosion Hazards	May decompose if contact is made with flames and heating elements. Container may explode if heated due to pressure rise. Combustion products are toxic.
Storage Conditions	The procedures / rules for R12 also apply to R134a.
Disposal Procedure	Reclaim

R-12, which has a boiling point of  $-21.6^\circ\text{F}$ , can still be found in older residential refrigerators and freezers. Special procedures must be followed to assure that none of the refrigerant escapes into the atmosphere. These procedures are covered in detail in Whirlpool Publication LIT4378421. These instructions are also included with Ozone Recovery Bags available through Whirlpool Parts Distribution. **Because of the potential for environmental damage, R-12 sealed systems should only be service by certified sealed system technicians.**

R-22, which has a boiling point of  $-41.4^\circ\text{F}$ , is a highly efficient refrigerant used in commercial refrigeration systems and air conditioners.

Always use eye protection when handling refrigerants. Although nontoxic, all refrigerants in a liquid state will freeze you if it comes in contact with unprotected skin.

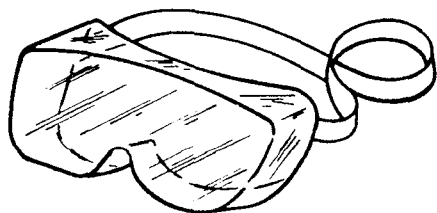

Let's replace the ice with a refrigerant...

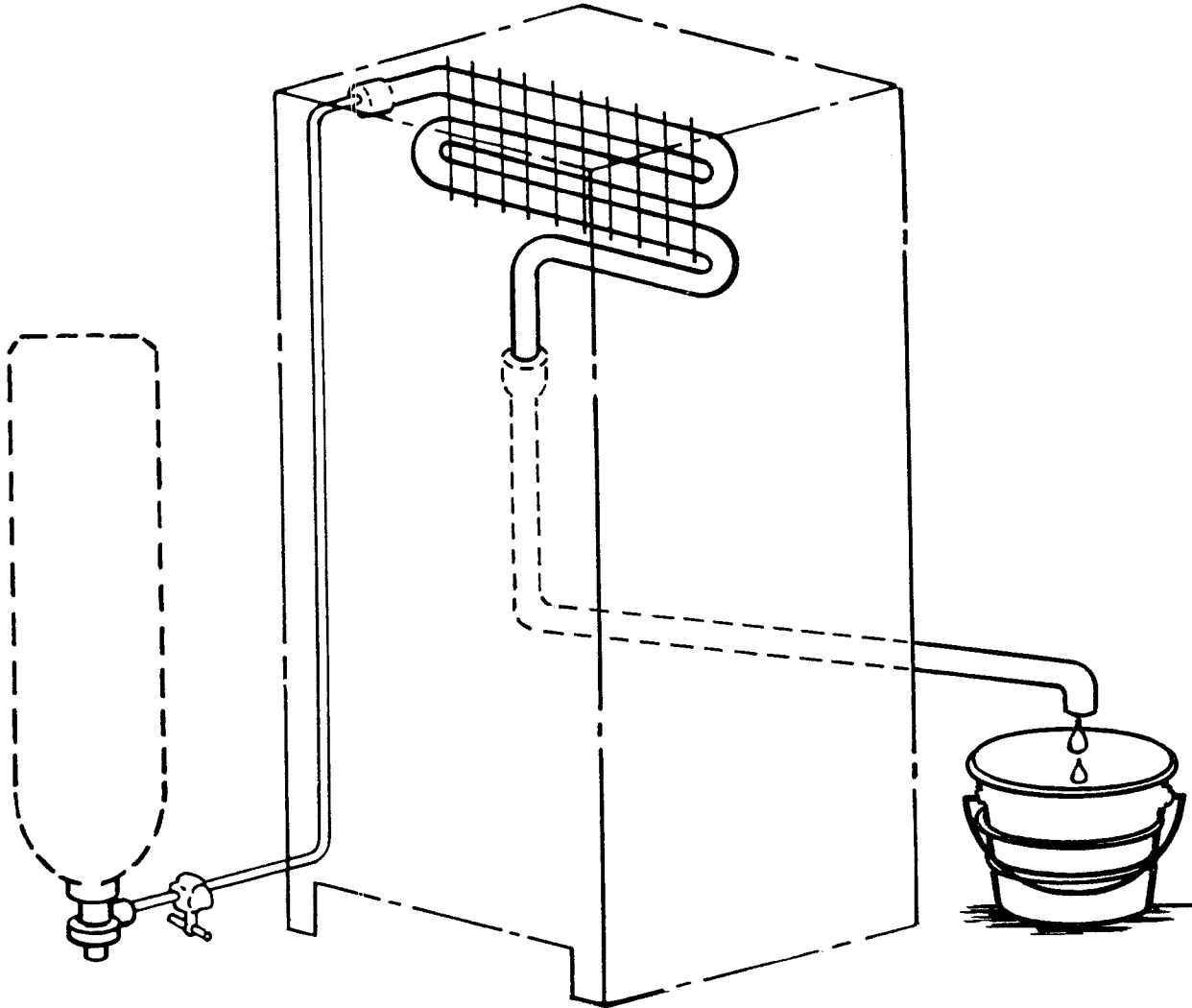

We will run our refrigerant through tubing into the ice box.... once inside we will run the tubing through metal fins which will allow heat to be transferred easily and then route the tubing to the outside of the ice box....

The refrigerant is in a compressed state in an inverted tank.... when we open the valve the refrigerant enters the tubing.... because of a change in pressure it turns to vapor inside the ice box as it absorbs the heat load... as stated in Rule 3 the boiling point is lowered by lowering the pressure.

If we follow our definition of refrigeration we must now remove the heat through a tube to the outside.

The metal fins act as a conductor of heat from the food to the refrigerant. This is called an evaporator because the refrigerant vaporizes inside it. It is made up of a highly conductive material and positioned in the refrigerator to maximize the heat removal process. The tubing is coiled to allow a greater amount of surface area to be covered. The evaporator in a refrigerator is a highly efficient heat removing device.

In our primitive refrigerator we vented the heated refrigerant to the outside. If we were to actually do this it would be lost. This would mean that we would have to keep purchasing new tanks of refrigerant in order to keep our refrigerator working. This would not be a very practical system.

We need to recover the refrigerant after it leaves the inside of the refrigerator and turn it back into a liquid. This is accomplished by adding two components. One is called a suction line and the other a compressor. The suction line is the connector between the evaporator and the compressor.

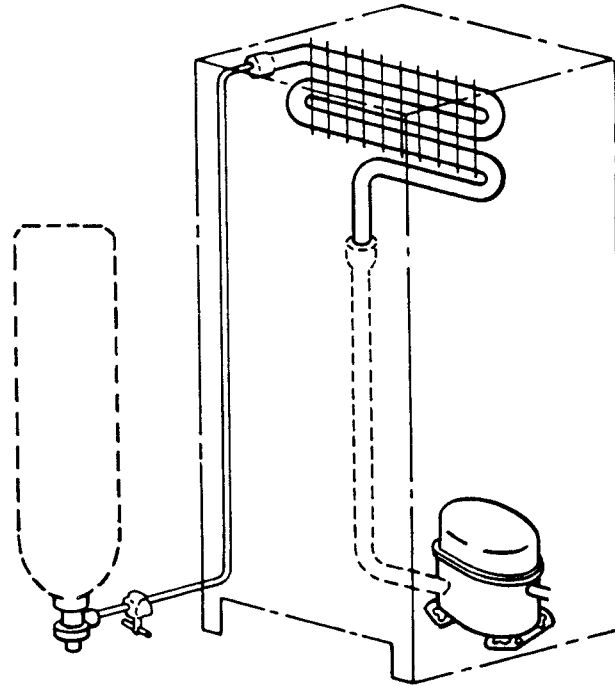

The compressor will apply a vacuum on the tubing making a pressure variance which allows the refrigerant to vaporize inside the evaporator.

Remember Rule 3. Low pressure causes the boiling point of the liquid to be lowered thereby allowing it to vaporize.

The vaporized gas is then sucked through the suction line into the compressor. In the compressor chamber the vapor is compressed.

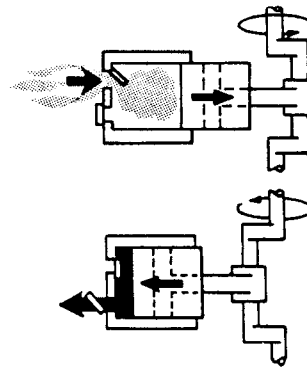
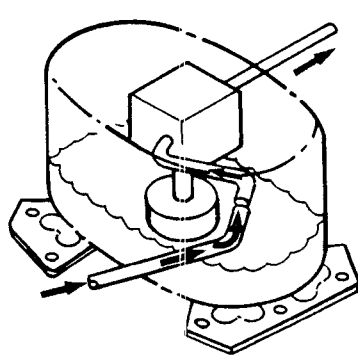

Once compressed the vapor is forced out of the chamber into tubing which leaves the compressor. This compressor discharge is under high pressure and because high pressure causes high temperature this vapor will be very hot.



We need to change the hot compressed vapor back into liquid so it can be reused again to extract heat from the refrigerator. We must now remove the heat from the vapor in order to allow it to condense back into a liquid form.

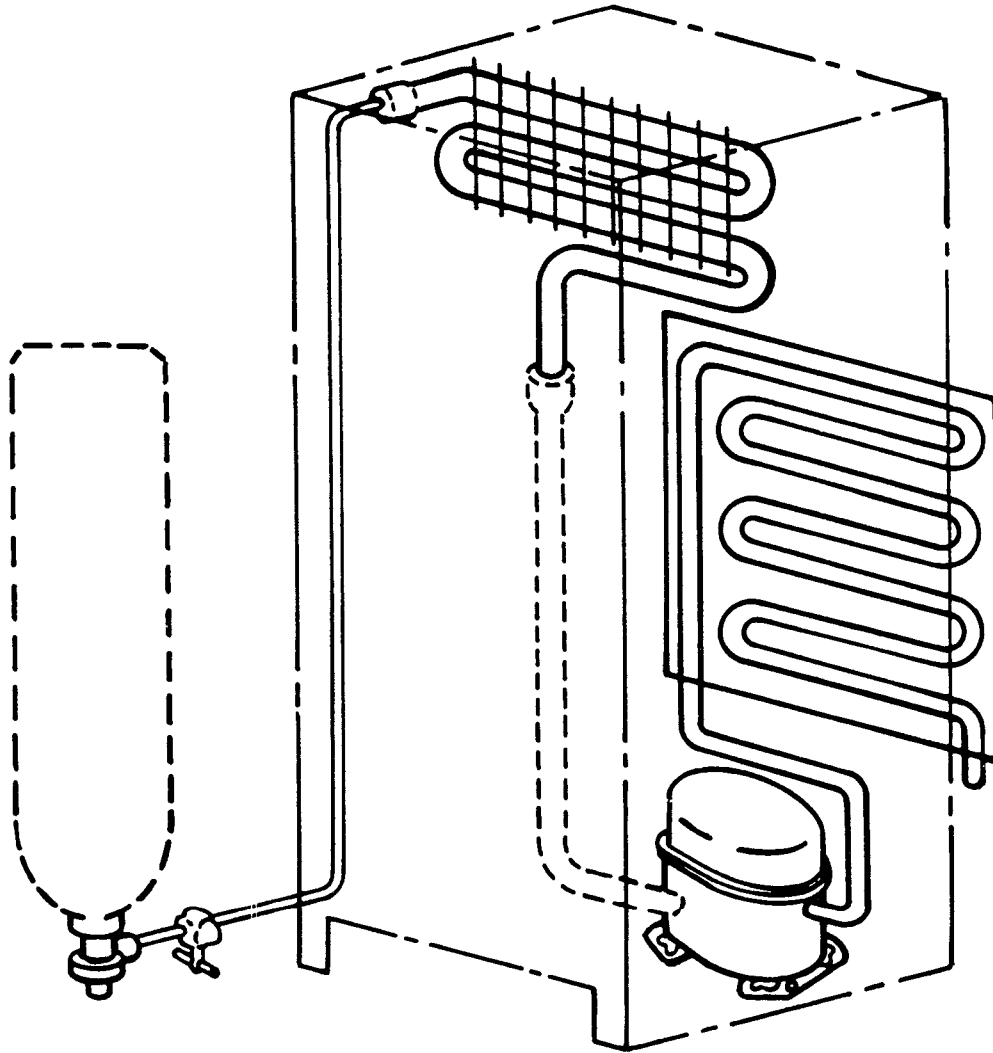

We can do this by running the vapor through a heat removal system called a condenser. Since the vapor is much hotter than the surrounding air outside the refrigerator, it will easily transfer its heat to the air which is moving across the condenser coils.

Remember Rule #2; Heat will always flow from hot to cold.

As the refrigerant gives up its heat it changes back to liquid form.

There are two basic types of condensers.

The first type uses a fan to move the air over the condenser coils. This is called a forced air condenser.

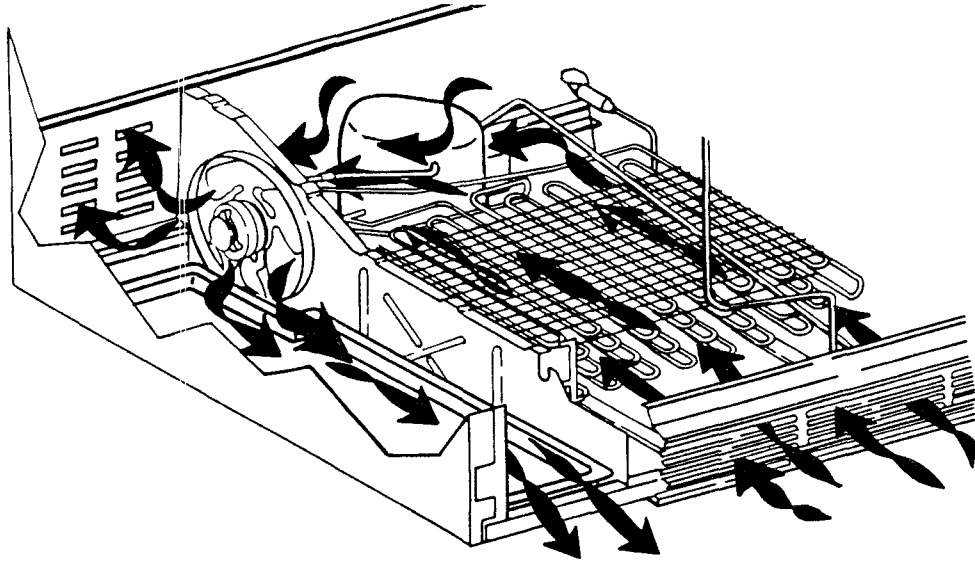

The second type is mounted on the back panel and acts like a chimney drawing the air up along the coils. This is a static air condenser.

The ability of air to flow across the condenser is critical.

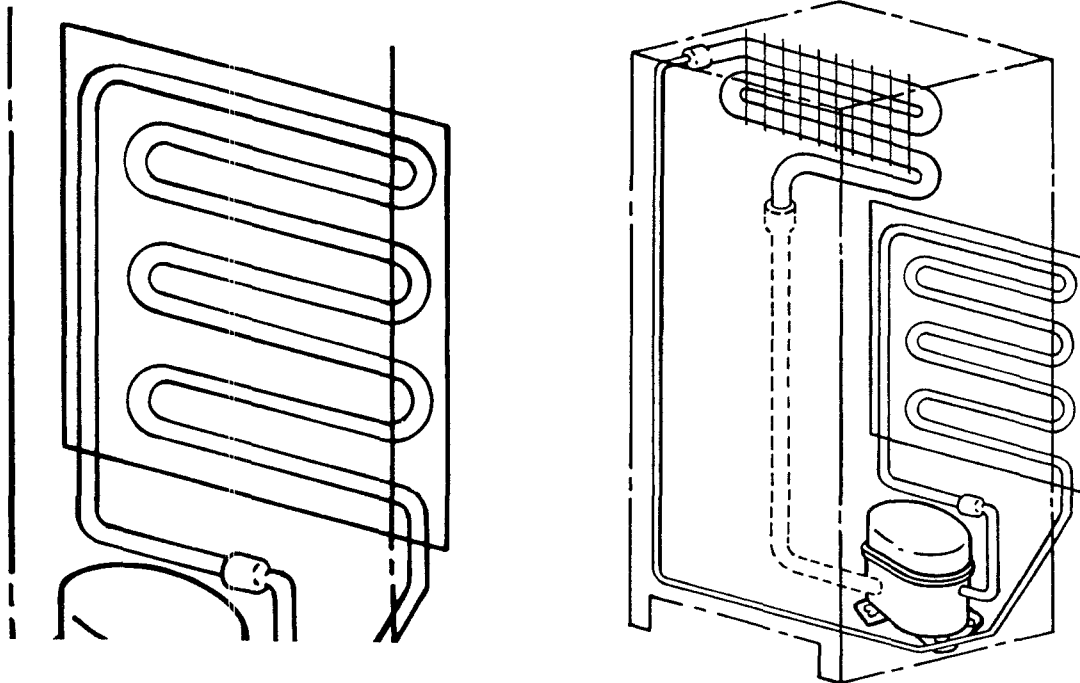

Once the refrigerant is liquified we need to route the liquid refrigerant back to the evaporator. We do this by routing a very small diameter tube to the evaporator. This tube is called a capillary tube.

It's purpose is to maintain the difference in pressure between the low-pressure evaporator and the high pressure condenser. It also acts as a regulating valve by controlling the flow of liquid refrigerant into the evaporator.

Now let's recap what we have just learned.

The main purpose of a refrigeration system is to preserve food by removing heat from it.

This is done in the evaporator as the liquid refrigerant is vaporized because of a dramatic pressure change which occurs when the liquid refrigerant enters the large diameter evaporator tube from the small diameter capillary tube.

The process of changing states from a liquid to a gas, (LATENT HEAT TRANSFER) allows the refrigerant to absorb a great amount of heat.

The compressor applies suction on the input side of the evaporator via the suction line and compresses the vapor from the evaporator causing it to heat up.

This high pressure, high temperature vapor is routed into the condenser where the cooler room air absorbs it's heat and allows the refrigerant to turn back into a liquid.

Once in liquid form the refrigerant is routed back into the capillary tube and sent back to the evaporator.

This is basically how a sealed system works.

## Exercise 1

"Basic Refrigeration Fundamentals".

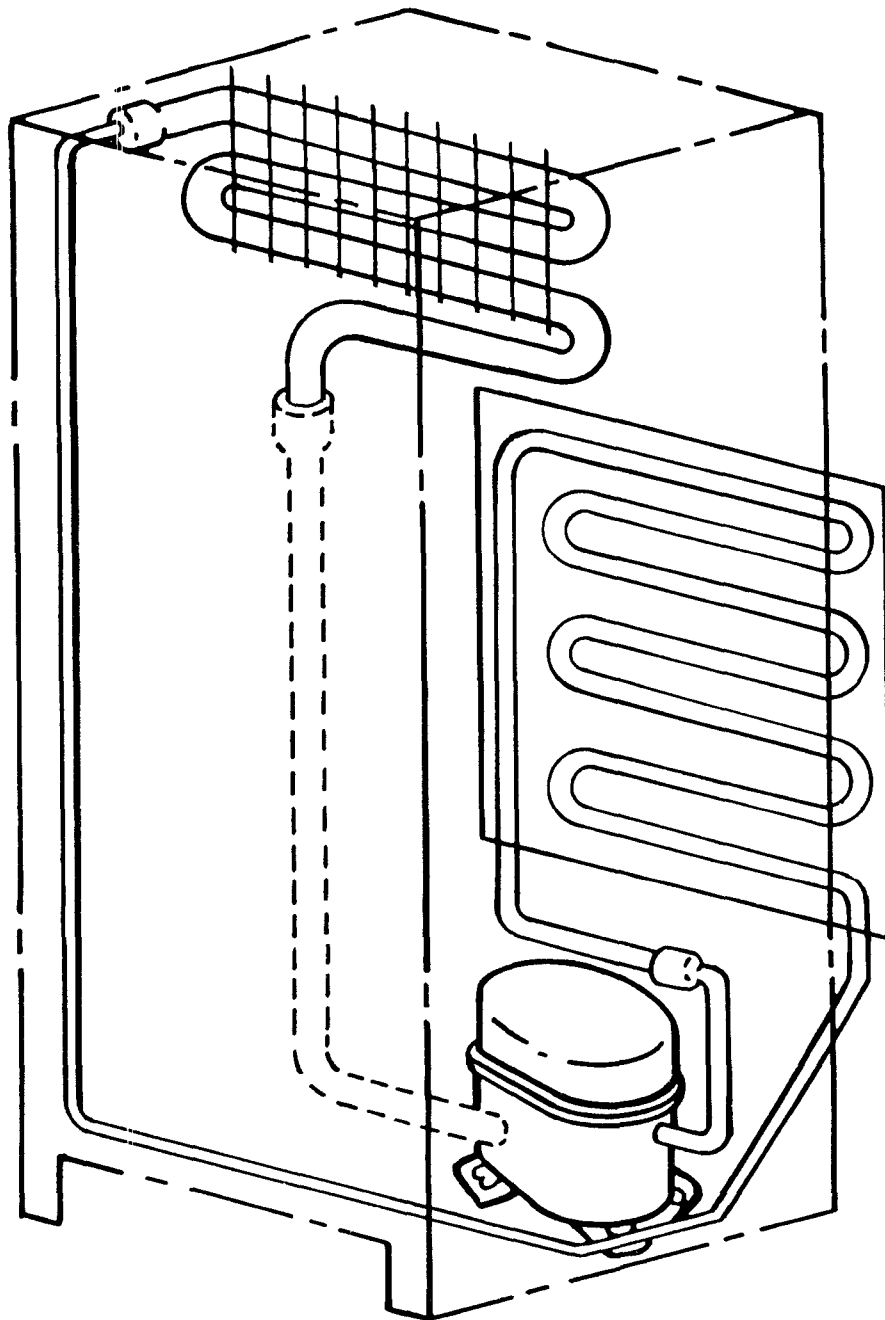

USING YOUR YELLOW MARKING PEN, SHOW THE LIQUID REFRIGERANT POSITION JUST AFTER START-UP ON A NEW PRODUCT

## Exercise 2

"Basic Refrigeration Fundamentals".

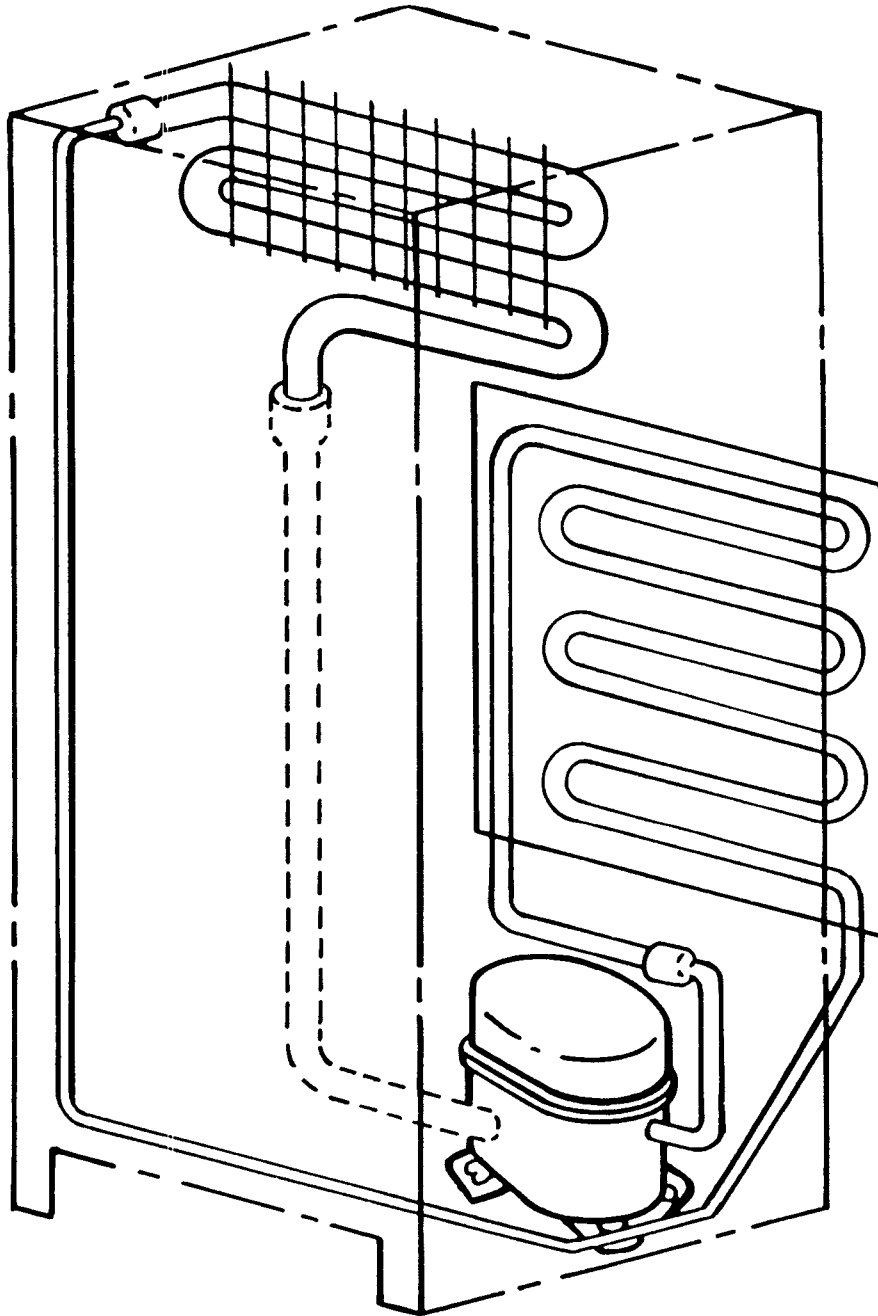

USING YOUR YELLOW MARKING PEN, SHOW THE LIQUID REFRIGERANT POSITION AT:

JUST BEFORE THERMOSTAT IS SATISFIED

### Exercise 3

"Basic Refrigeration Fundamentals".

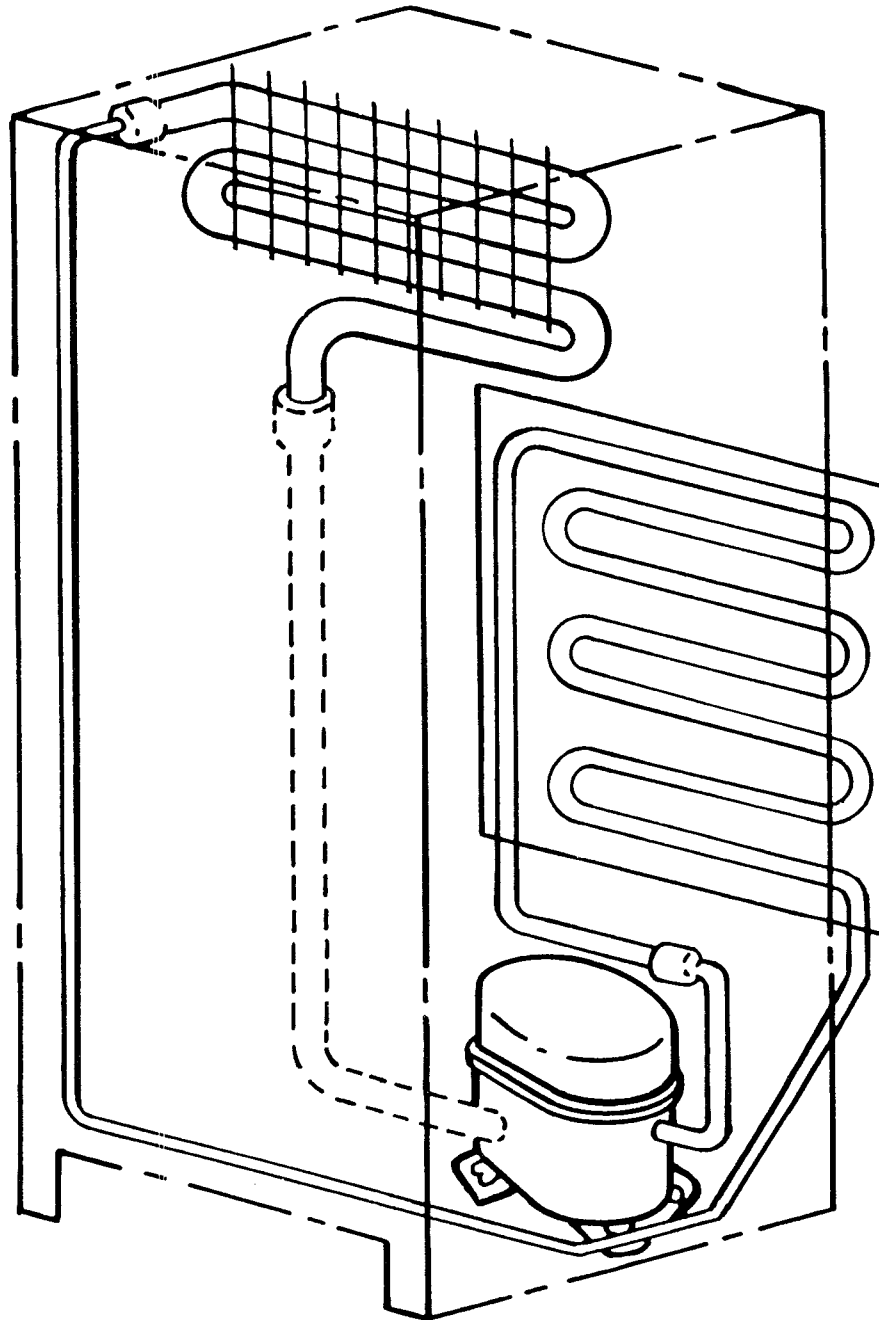

USING YOUR YELLOW MARKING PEN, SHOW THE LIQUID REFRIGERANT POSITION AT:

5 MINUTES AFTER COMPRESSOR SHUT-DOWN

NOW WITH YOUR GREEN PEN SHOW THE VAPORIZED REFRIGERANT LEVELS ON EXERCISES 1,2,AND 3

SHOW YOUR WORK TO YOUR INSTRUCTOR



# EXTRA

"Basic Refrigeration Fundamentals".

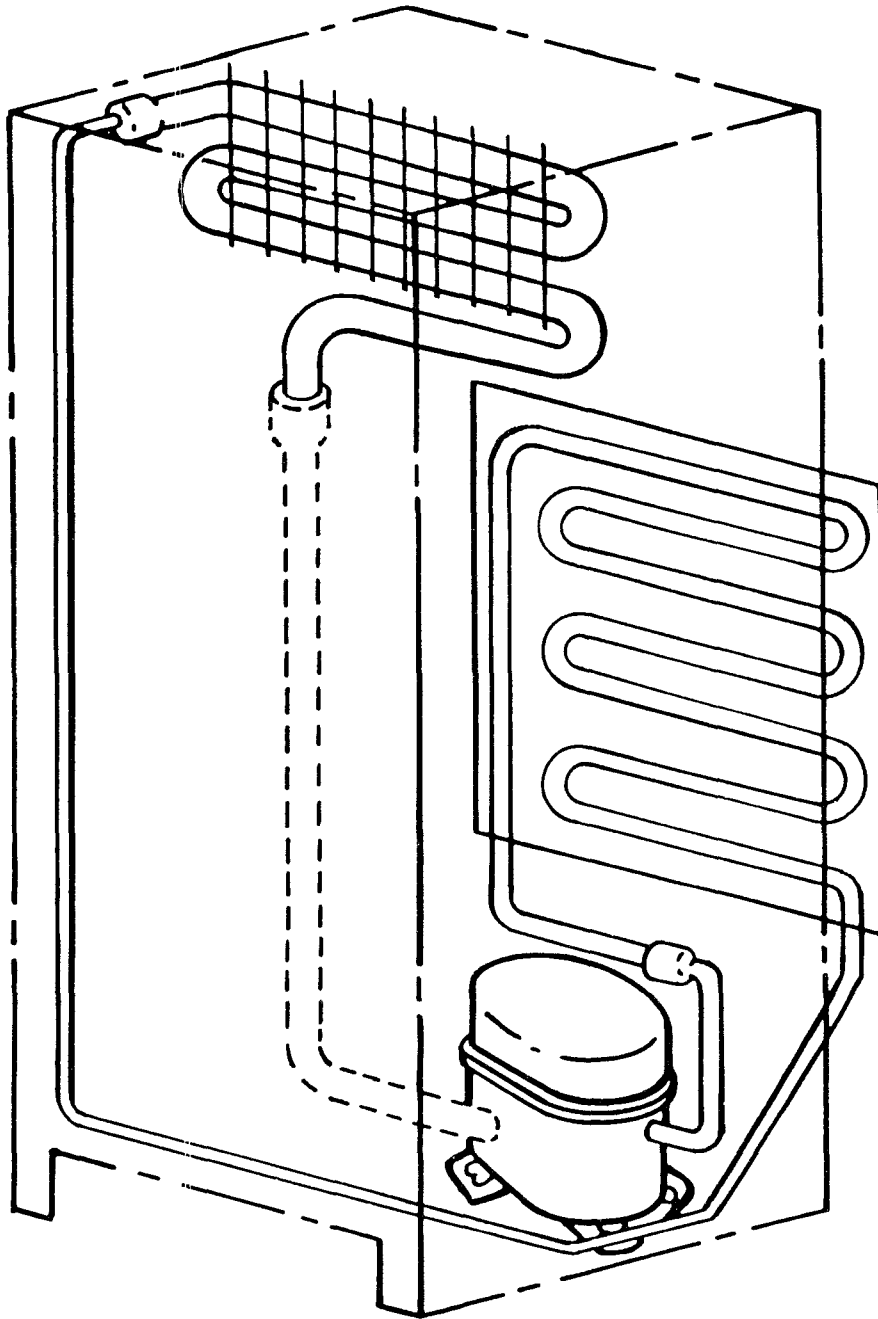

YELLOW = LIQUID REFRIGERANT POSITION  
GREEN = VAPOR REFRIGERANT POSITION

## "SECTION 3" OTHER REFRIGERATION COMPONENTS

Now that we have covered the basic refrigeration system we will add a few more components to our basic system in order to make it work more effectively.

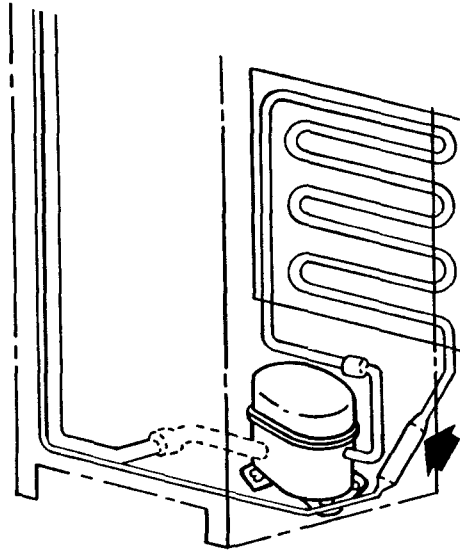

The drier is added to the system at the junction between the condenser and the capillary tube. The purpose of the drier is to remove any moisture in the refrigerant so that a moisture restriction does not occur in the evaporator.

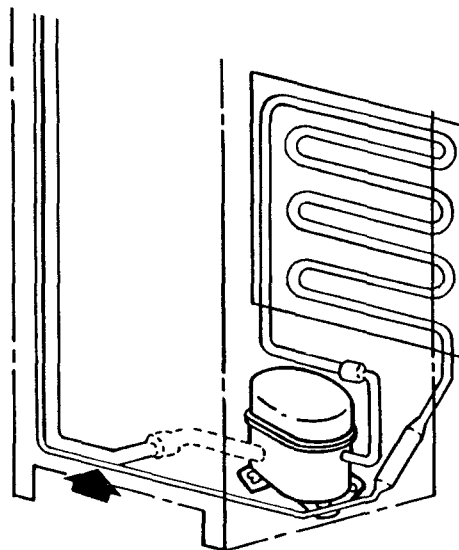

The heat exchanger will make our refrigerator more efficient. The heat exchanger is formed by soldering the cap tube to the evaporator suction line. The heat absorbed from the cap tube will raise the temperature of the suction line enough to keep it from sweating. In addition this allows the liquid refrigerant in the cap tube to be further cooled by the vaporized refrigerant in the suction line.

Other components in our basic refrigeration system.

**ACCUMULATOR**-An accumulator is found at the base or last pass of the evaporator in refrigerators requiring larger amounts of refrigerant. It is used to accumulate liquid refrigerant and prevent the liquid refrigerant from returning to the compressor. If liquid was to enter the compressor, the pump could be damaged since it is not able to compress liquid refrigerant. As you can see here, the suction line inlet is higher than the refrigerant level in the accumulator, thus, only the refrigerant vapor will enter the suction line to the compressor in a properly charged sealed system.

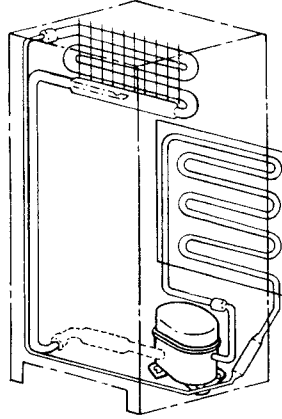

**DIRECT ENTRY SUCTION PUMP**-A new term referring to a variation in piston compressors. Previously, vaporized refrigerant was dumped into the compressor dome from the suction line. The vaporized refrigerant would then be pulled into the piston chamber. The direct entry suction pump redirects the internal tubing so that, except for a 1/4 inch gap, the suction line tubing meets directly with the input tube on the piston.

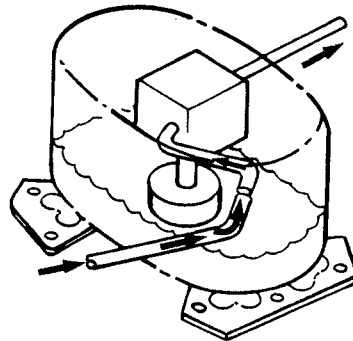

**MUFFLER**-A muffler used on those sealed systems where a direct entry suction pump is used. It looks similar in appearance to a dryer. It is positioned on the suction line just before the compressor. The purpose of the muffler is to act as a break between the compressor and the evaporator. This minimizes any vibration sound that could be there.

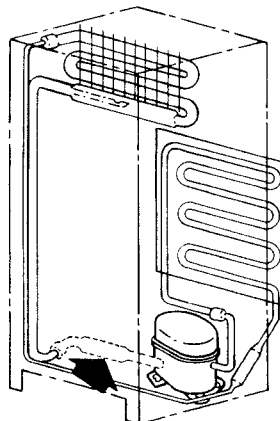

**Review Exercise**  
**“OTHER IMPORTANT REFRIGERATION COMPONENTS”**

Draw the following:

Dryer    Heat exchanger    Accumulator    All the connecting tubing for a sealed system.

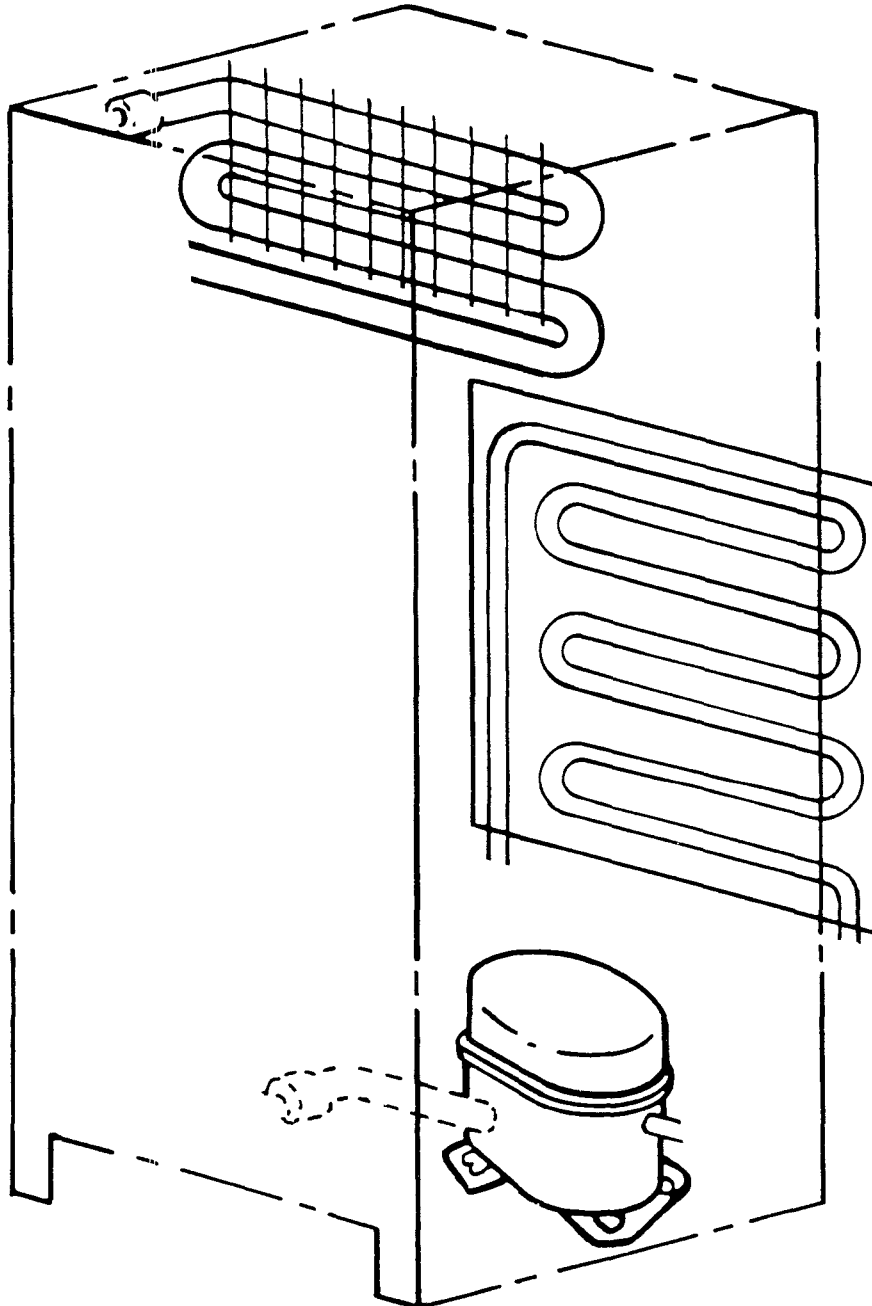

USING YOUR YELLOW MARKING PEN SHOW THE LIQUID REFRIGERANT POSITION JUST BEFORE THE THERMOSTAT IS SATISFIED.  
SHOW THE VAPORIZED REFRIGERANT POSITION WITH YOUR GREEN MARKING PEN.

**EXTRA**  
**Section 3 Exercise**  
**“OTHER IMPORTANT REFRIGERATION COMPONENTS”**

Draw the following:

Dryer    Heat exchanger    Accumulator    All the connecting tubing for a sealed system.

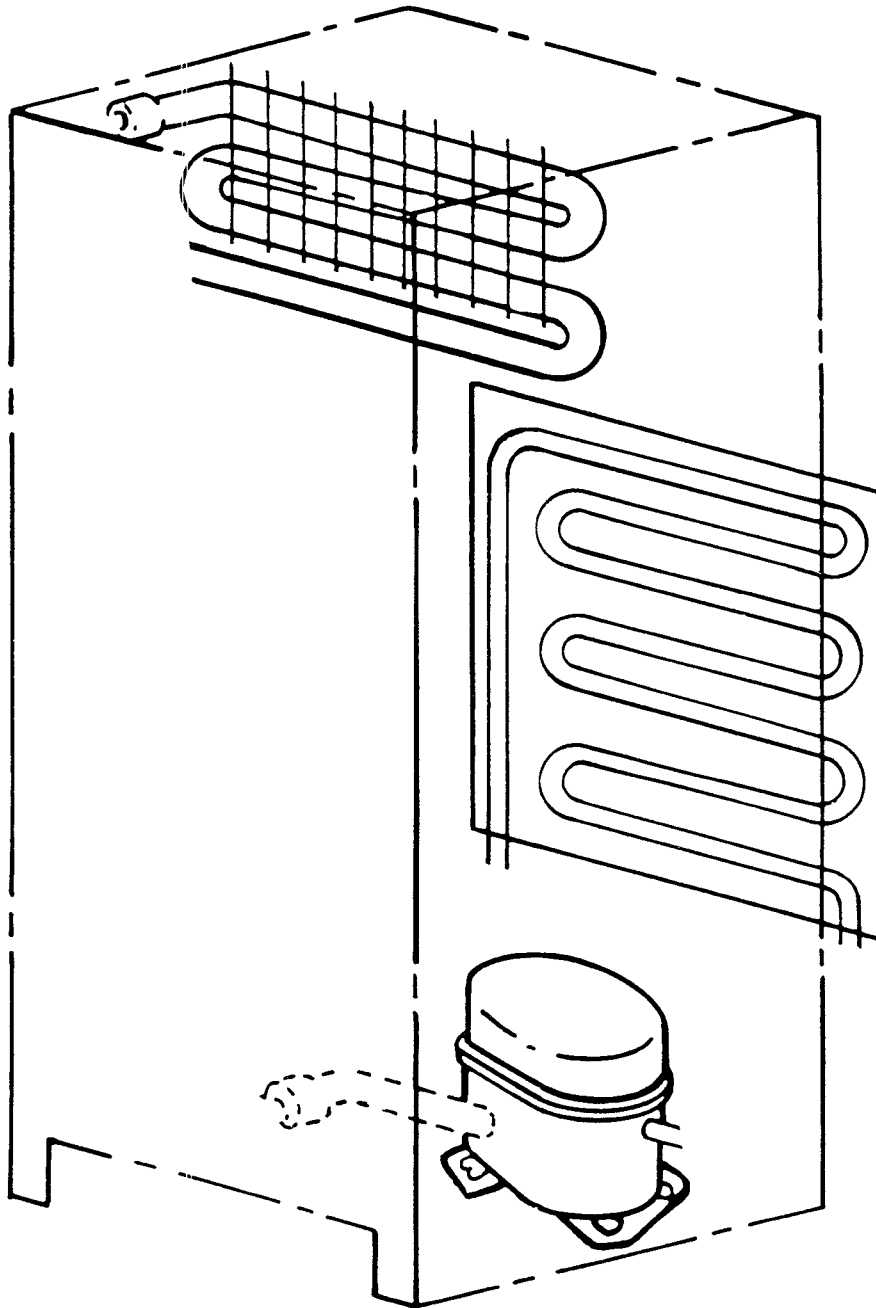

USING YOUR YELLOW MARKING PEN SHOW THE LIQUID REFRIGERANT POSITION JUST BEFORE THE THERMOSTAT IS SATISFIED. SHOW THE VAPORIZED REFRIGERANT POSITION WITH YOUR GREEN MARKING PEN.

# "SECTION 4" WIRING DIAGRAMS

In this section we will be reviewing the wiring diagrams for a typical refrigerator...

## SERVICE AND WIRING SHEET 1122147 (FORMERLY TECH SHEET)

A new Generic Tech Sheet is being provided with each refrigerator. The location of the tech sheet is directly behind the front grill as close as possible to the front.

On refrigerators without a grill, the Service and Wiring sheet can be found in the front right corner.

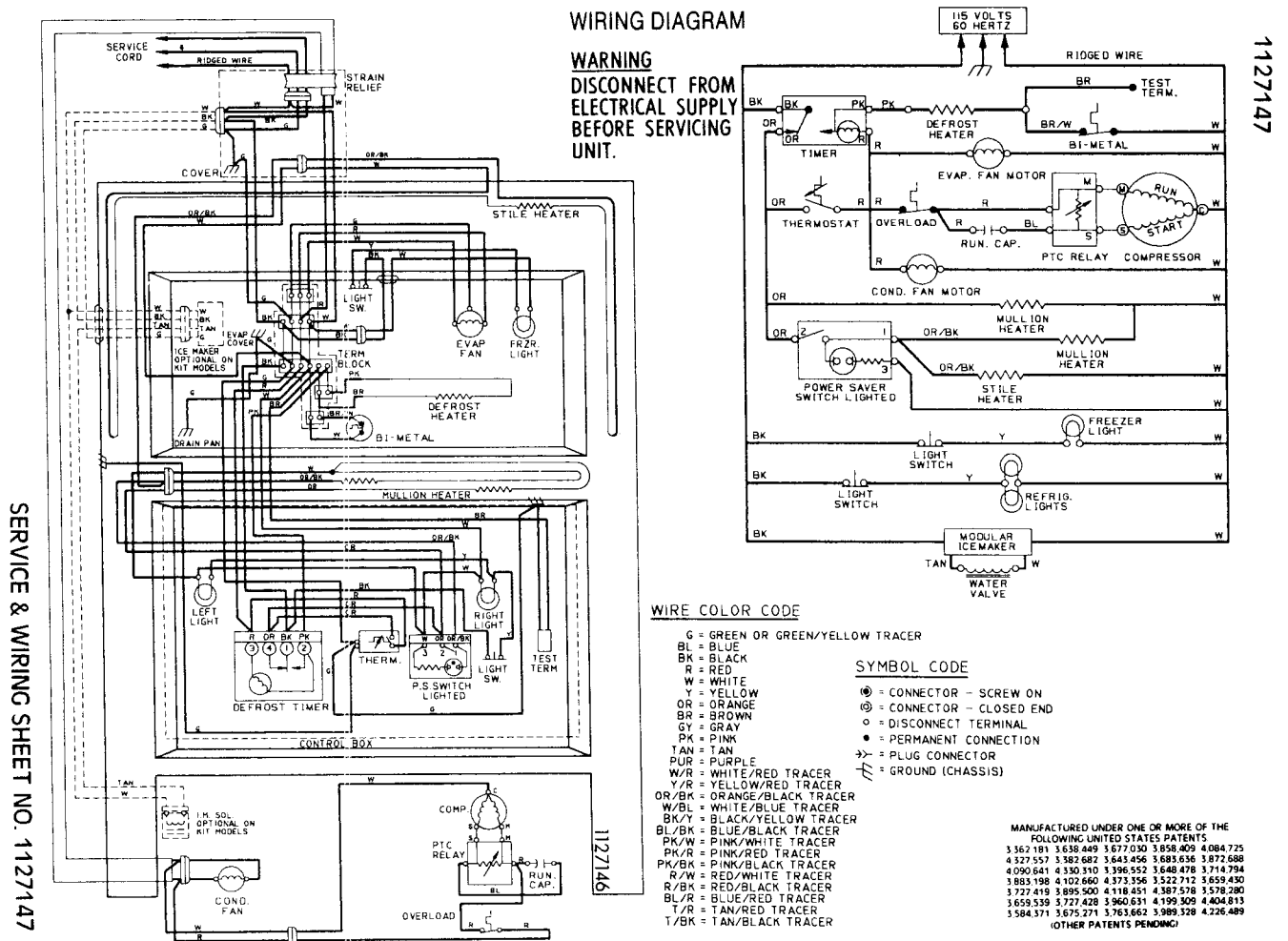

Printed in U.S.A.



PERFORMANCE DATA			
*(NORMAL OPERATING CONDITIONS)			
AMB	WATTS	SYSTEM PRESSURE (PSIG)	
		HIGH SIDE	LOW SIDE
70°	200±20	110±20	-5" TO 5#
90°	210±20	145±20	-2" TO 5#
110°	220±20	190±20	0" TO 6#

\*Normal operating conditions are viewed when the air and temperature controls are at mid-setting, freezer section 0 to -5F and unit is cycling.

NOTE: Watt and pressure readings will vary and are influenced by the existing condition of the appliance, such as iced-up evaporator, condition of condenser, defrost cycle, pull-down time and customer use.

**SERVICE INFORMATION (1118990)**

1. COMPRESSOR SUCTION AND PROCESS STUBS MAY **NOT** BE INTERCHANGED UNLESS INDICATED BY **★★**.
2. REFRIGERANT CHARGE MUST BE APPLIED TO HIGH SIDE ONLY.
3. ICE MAKER AND WATER VALVE NOT ORIGINAL EQUIPMENT ON ALL MODELS.
4. **CAUTION:** ICE MAKER CYCLE **MUST** BE INITIATED ELECTRICALLY. DO NOT TRY TO MANUALLY START CYCLE.
5. **SERVICE STILE HEATER:** IF SERVICE HEATER IS PRESENT AND ADDITIONAL STILE HEAT IS DESIRED. CUT OR/BK WIRE (UNDER WIRING COVER AT REAR OF CABINET) AND SPLICE IN OR WIRE.

As you will see when reviewing the refrigerators in Section 5, the note about watt and pressure readings is very important.

**SERVICE DEFROST BIMETALS**  
**PORCELAIN LINER MODELS—70° F OPEN**  
**PLASTIC LINER MODELS—50° F OPEN**

<b>GENERAL COMPONENT INFORMATION FOR ALL REFRIGERATOR/FREEZER MODELS</b>		
<b>BE SURE AND USE CORRECT REPLACEMENT PARTS</b>		
<b>COMPONENT (IF APPLICABLE)</b>	<b>WATTAGE @ 120V</b>	<b>OHMS RESISTANCE</b>
DEFROST HEATER	525-750	19-27
COMPRESSOR:		
RUN WINDINGS	—	1-4
START WINDINGS	—	4-18
EVAPORATOR FAN	8-12	—
CONDENSER FAN	12-15	—
MULLION HEATER	3-7	2050-4800
MULLION HEATER/POWER SAVER	3-10	1440-4800
STILE HEATER/POWER SAVER	3-10	1440-4800
SERVICE STILE HEATER	10-17	840-1440
DISPENSER HOUSING HEATER (DOOR)	2-6	2400-7200

# COMPRESSOR OPTIONS—REFER TO APPLICABLE DESIGN

(OIL COOLER NOT PRESENT ON ALL COMPRESSORS)

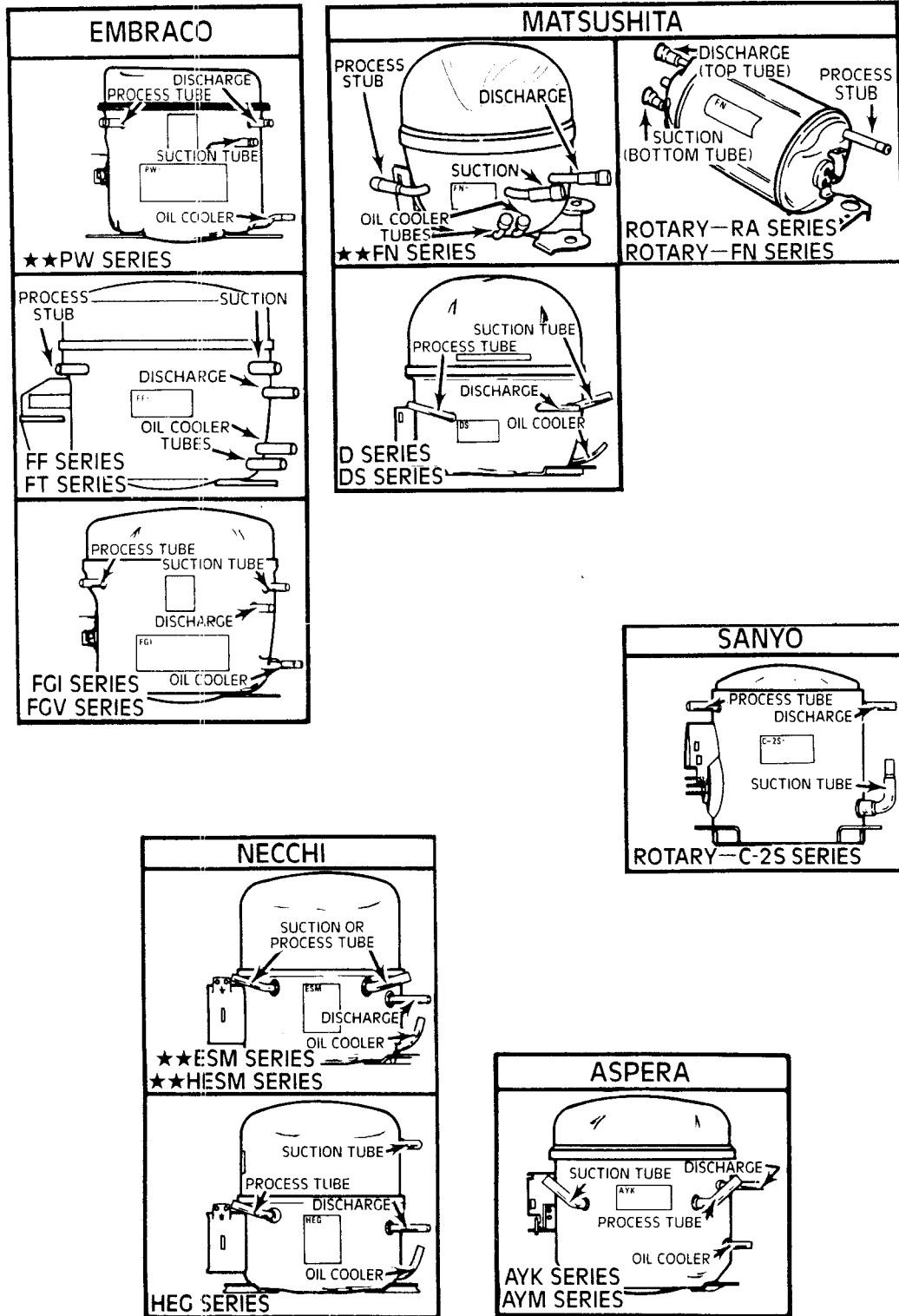

1. COMPRESSOR SUCTION AND PROCESS STUBS MAY **NOT** BE INTERCHANGED UNLESS INDICATED BY ★★.

It is important to correctly eliminate electrical component failures before assuming a sealed system failure. In the typical refrigerator there are four basic circuits.

- The refrigeration system circuits.
- The defrost system circuits.
- The mullion/Stile anti-sweat heater circuits and .
- The icemaker circuit

This program will concentrate on the refrigeration circuits of a no-frost refrigerator. In order to understand the refrigeration circuit we must first have a common understanding of some basic terms.

**LOADS**-A load is a current drawing component in the circuit. All loads have resistance. Loads provide heat, light or motion.

With your GREEN marking pen identify the loads in this diagram. Once you have completed this exercise go to the next page and complete that exercise.

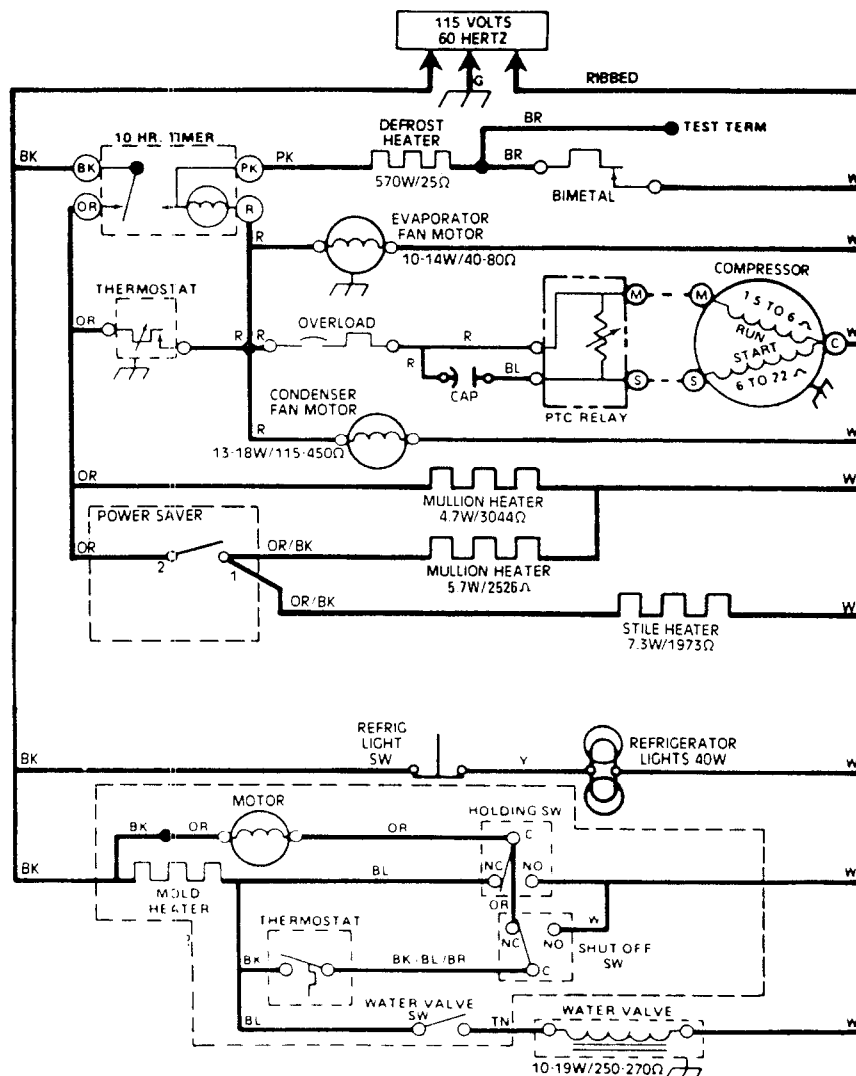

**SWITCHES**-Switches are devices that control the flow of current. Switches are designed to either allow current to flow or they may be in a system to stop current from flowing.

If, for example, we were troubleshooting a refrigerator that had a compressor that would not run, we can see that there are four switches that are used to make the compressor run.

**WITH YOUR YELLOW MARKING PEN IDENTIFY THE SWITCHES THAT ARE USED TO KEEP THE COMPRESSOR RUNNING. SHOW YOUR WORK TO YOUR INSTRUCTOR.**

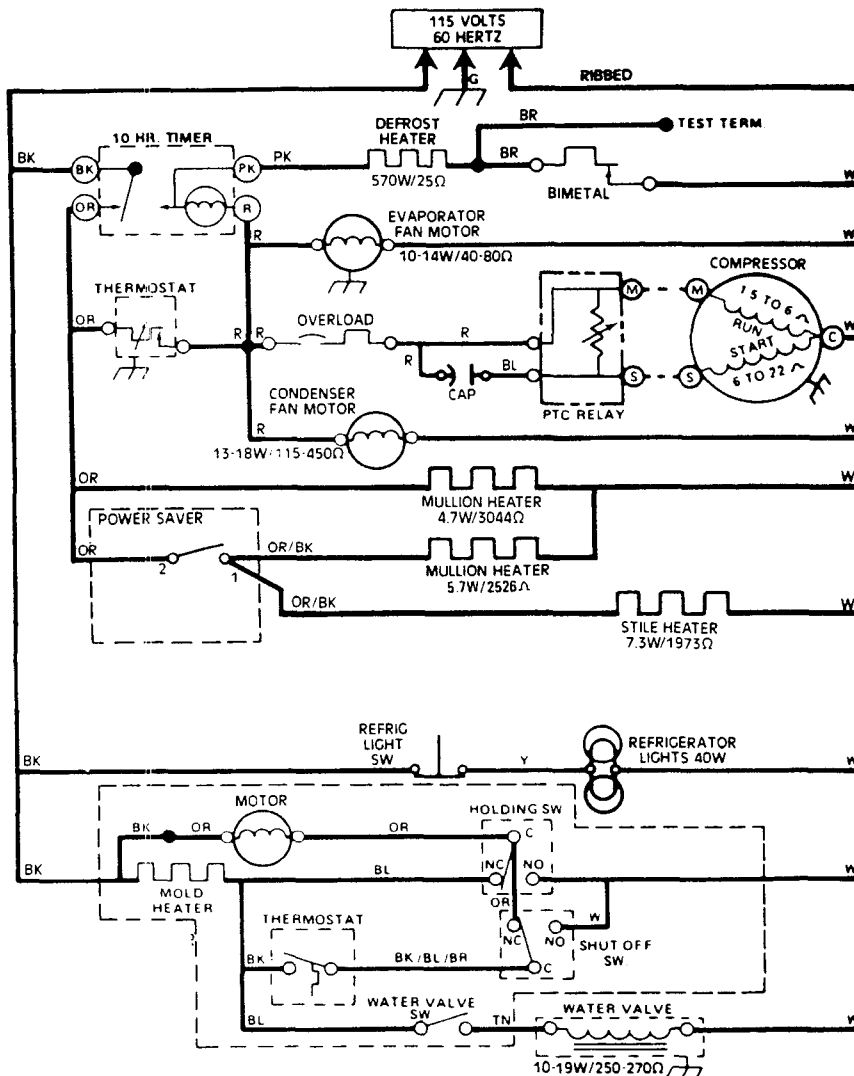

The loads in this refrigeration cycle diagram are:

- The PTC Relay
- The Compressor
- The Condenser Fan Motor
- The Evaporator Fan Motor
- The Defrost Timer Motor
- The Defrost Heater

These are the switches in the refrigeration wiring diagram:

- Defrost Timer
- Thermostat
- Overload
- PTC Relay
- Defrost Bi-Metal

Now that you have had a discussion with your instructor as to whether the PTC relay is a load or a switch, let's discuss it in more detail.

There are several different start relays used on compressors in refrigeration. These start relays are categorized into two types:

Type A, the traditional relay with copper windings.

Type B, the more commonly used P.T.C. relay, which is solid state.

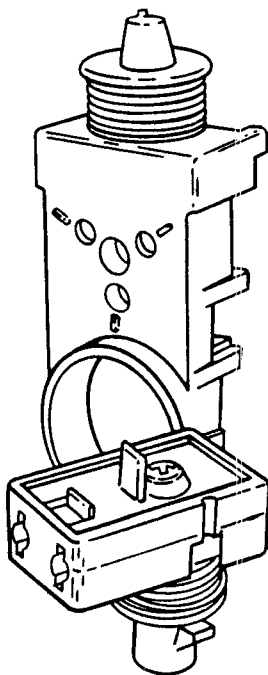

**Type A**

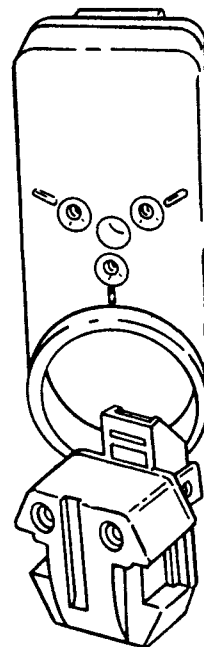

**Type B**

What is a P.T.C. relay? A P.T.C. relay is a Positive Temperature Coefficient variable resistor. It is made of ceramic and then sprayed with a metal. It is often referred to as the "pill". This pill is a conductor that allows current to pass through it.

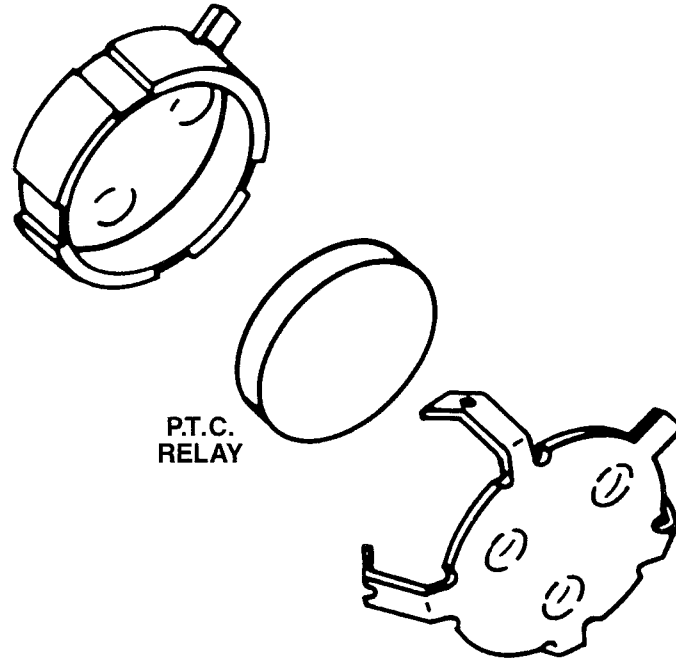

At the instant of start as the temperature increases, the resistance increases (a positive temperature coefficient relationship). This resistance builds to a point called a switch-point.

START

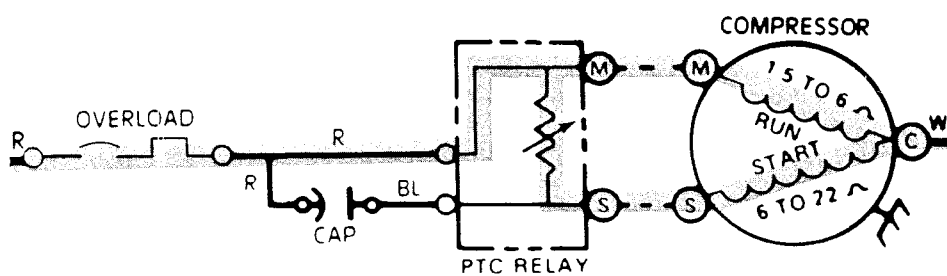



At this point, the P.T.C. relay can no longer conduct electricity and acts as an open switch. Now, the run capacitor limits current and also acts to smooth out the changing magnetic fields while the motor is running to make it more efficient.

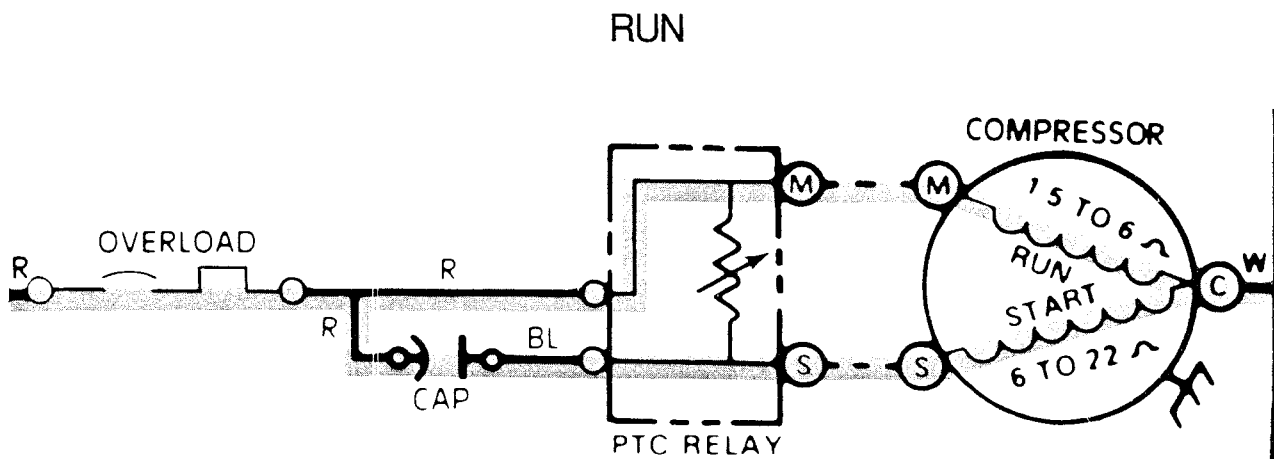

The elimination method is used for testing the P.T.C. relays. Check the "loaded" voltage at the compressor. Unplug the refrigerator.

**CAUTION: P.T.C. MAY BE EXTREMELY HOT!**

First, discharge capacitors if they are used. Then with an ohm meter, check if the needle deflects towards zero and then reverse towards infinite resistance (R x 10K). If the overload is separate, check continuity through the overload. Using a fused test cord, test the compressor to check if it runs. If the compressor checks good, then the relay is the problem.

Now, does a P.T.C. create heat, light, or motion?  
Does it act as a switching devise?

Yes, Yes.

There are two basic types of circuits in a refrigeration wiring diagram. The first type is called a series circuit. In a series circuit two or more components are joined together in the path between the hot side and the neutral side of the line.

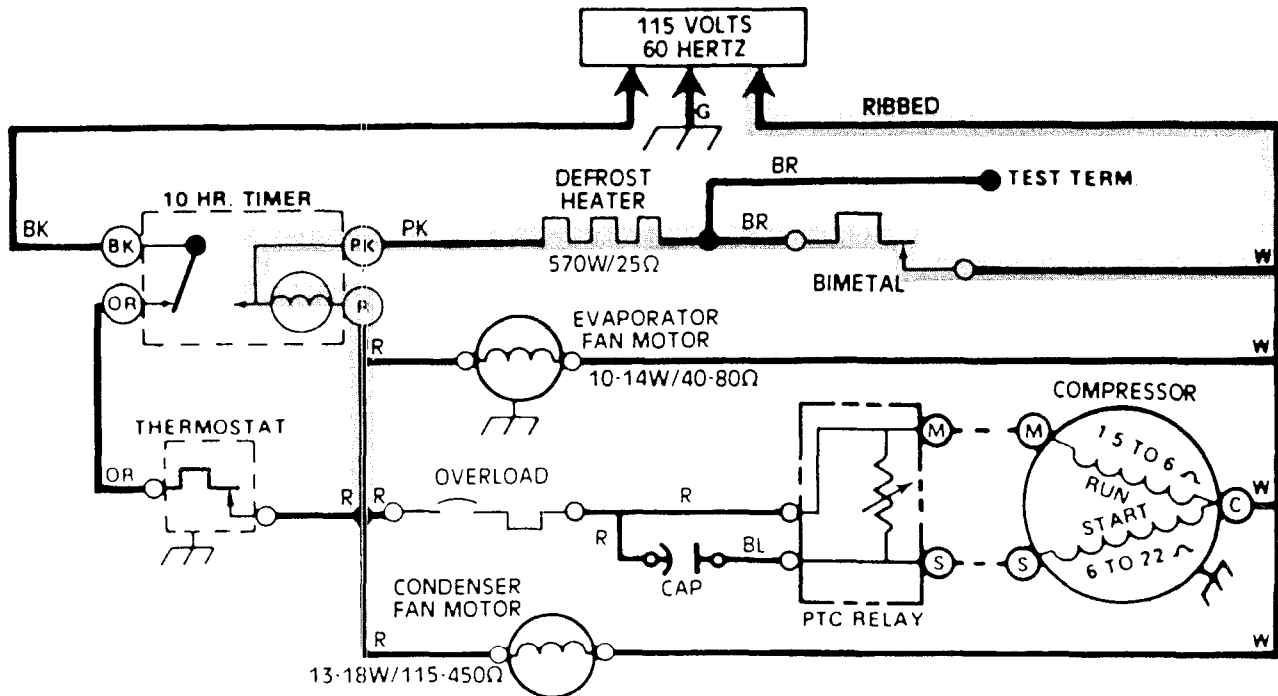

As you can see, current starts at the connector and proceeds through the: Defrost timer, thermostat, Timer Motor, Through the Defrost Heater, Through the Bi-Metal, and to the neutral lug of the power cord.

The two loads in this circuit are the timer motor and the defrost heater. Because of a large difference in resistance between the two components; The timer motor being 3000 OHMS while the defrost heater only being 20-30 OHMS. Most of the circuit's energy will be used by the timer motor. The defrost heater, therefore, will not have that much voltage through it and therefore, it will essentially not work. It will act as a piece of wire to complete the circuit.

If the Bi-Metal were open in this circuit .... current flow through this circuit would be stopped.

The other type of circuit in a refrigeration wiring diagram is called a parallel circuit. What a parallel circuit means is that there is more than one path for current to follow. If we are going from connector to the neutral side of the power, we could see that there are several paths that current could follow.

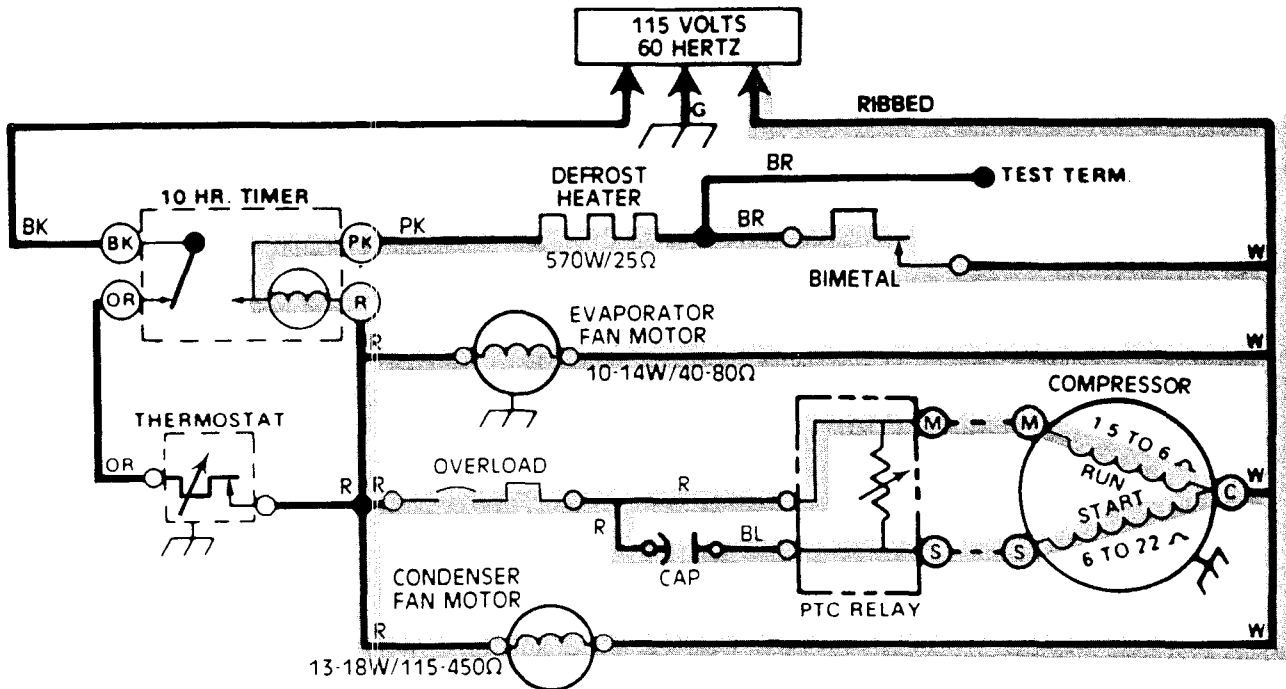

One would be through the defrost timer and defrost heater. Another would be through the overload switch, PTC relay and through the compressor. The third would be through the evaporator fan motor and the fourth, would be through the condenser fan motor.

What happens in parallel circuits is that each leg of the parallel circuit will have the same voltage applied as each of the other legs. It will use all of the voltage that is applied.

Whenever having problems with a refrigerator be sure to rule out electrical component failures prior to assuming a sealed system failure. In order to accomplish this you need to understand how the refrigerator's electrical system works.

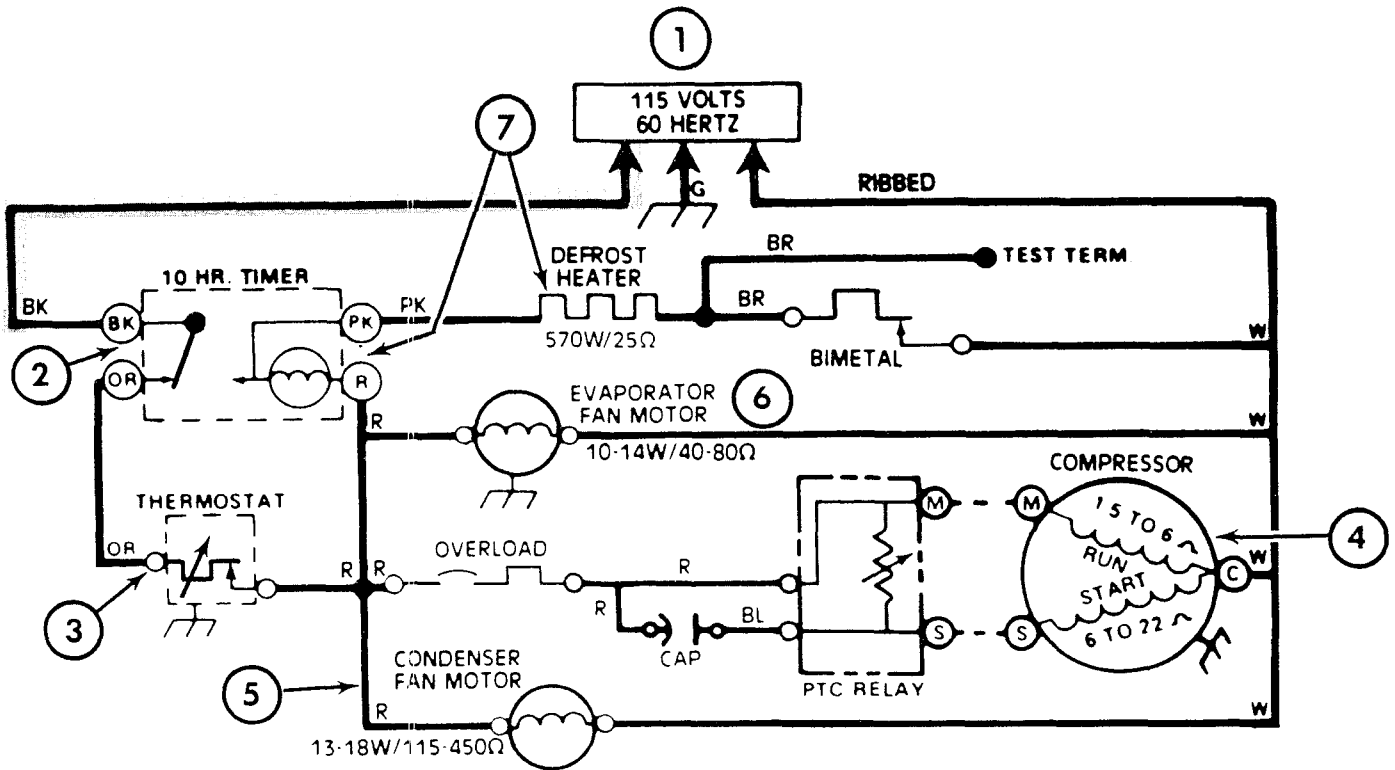

Lets look at this diagram and see what's going on in our refrigerator.

As you read this trace the path with your yellow marking pen.

- 1 When the refrigerator is plugged in power is applied between the two terminals of the refrigerator.
- 2 Power goes from the source to the defrost timer;
- 3 Through the defrost timer and to the thermostat.
- 4 If the thermostat senses that there is to much heat in the refrigerator it makes the connection and provides power to the compressor circuit,
- 5 Condenser fan motor,
- 6 The evaporator fan motor,
- 7 And the defrost timer circuit, .

The defrost heater will not be heating at this time because all the power in this circuit will be consumed by the timer motor. Remember why?

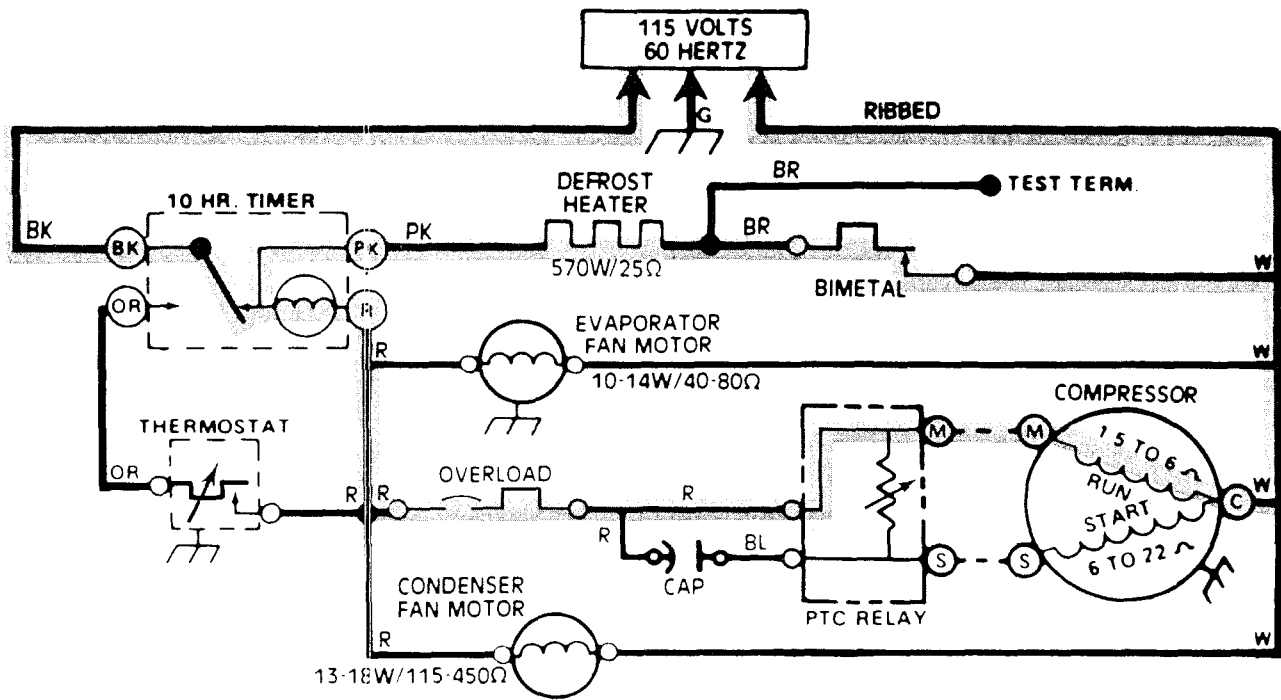

When the defrost timer has advanced through 10 hours of compressor run time the switch inside the defrost timer switches from the orange contact to the other side of the timer motor.

Now current in this circuit would flow through the timer motor, down through the compressor winding to the neutral side of the power. In this mode the defrost timer draws most of the power in this circuit the compressor will not have enough power to run.

A parallel circuit would go through the defrost heater, and bi-metal. Since the current is flowing directly through the defrost heater it will have enough voltage through it to heat the defrost heater.

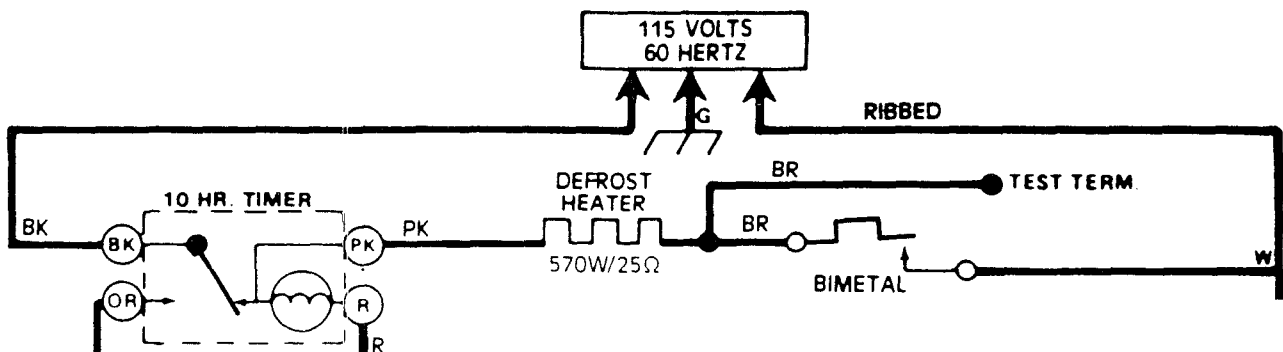

Once the evaporator temperature reaches 50 degrees the Bi Metal will open. This is the defrost cycle. When the 21 minute defrost cycle is complete the switch inside the defrost timer will again connect black to orange and the defrost heater will essentially be taken out of the circuit.

WITH YOUR GREEN MARKING PEN, MARK THE SERIES CIRCUIT DURING THE REFRIGERATION CYCLE.

WITH YOUR YELLOW MARKING PEN, MARK THE SERIES CIRCUIT DURING THE DEFROST CYCLE.

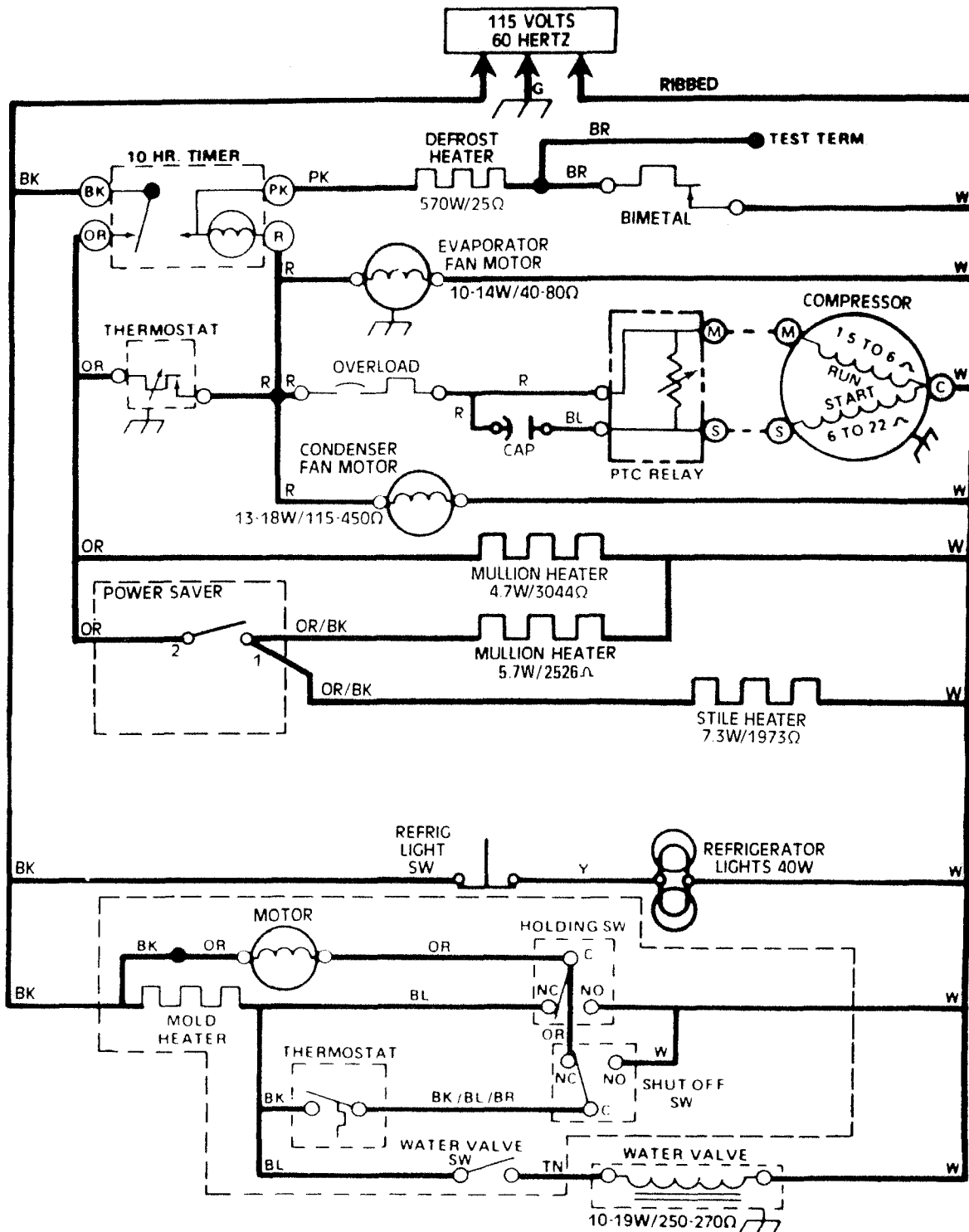

WITH YOUR GREEN MARKING PEN, WHEN THE THERMOSTAT IS CALLING FOR HEAT REMOVAL, MARK THE COMPRESSOR CIRCUIT.

WITH YOUR YELLOW MARKING PEN, MARK THE CIRCUITS THAT ARE PARALLEL TO THE COMPRESSOR CIRCUIT.

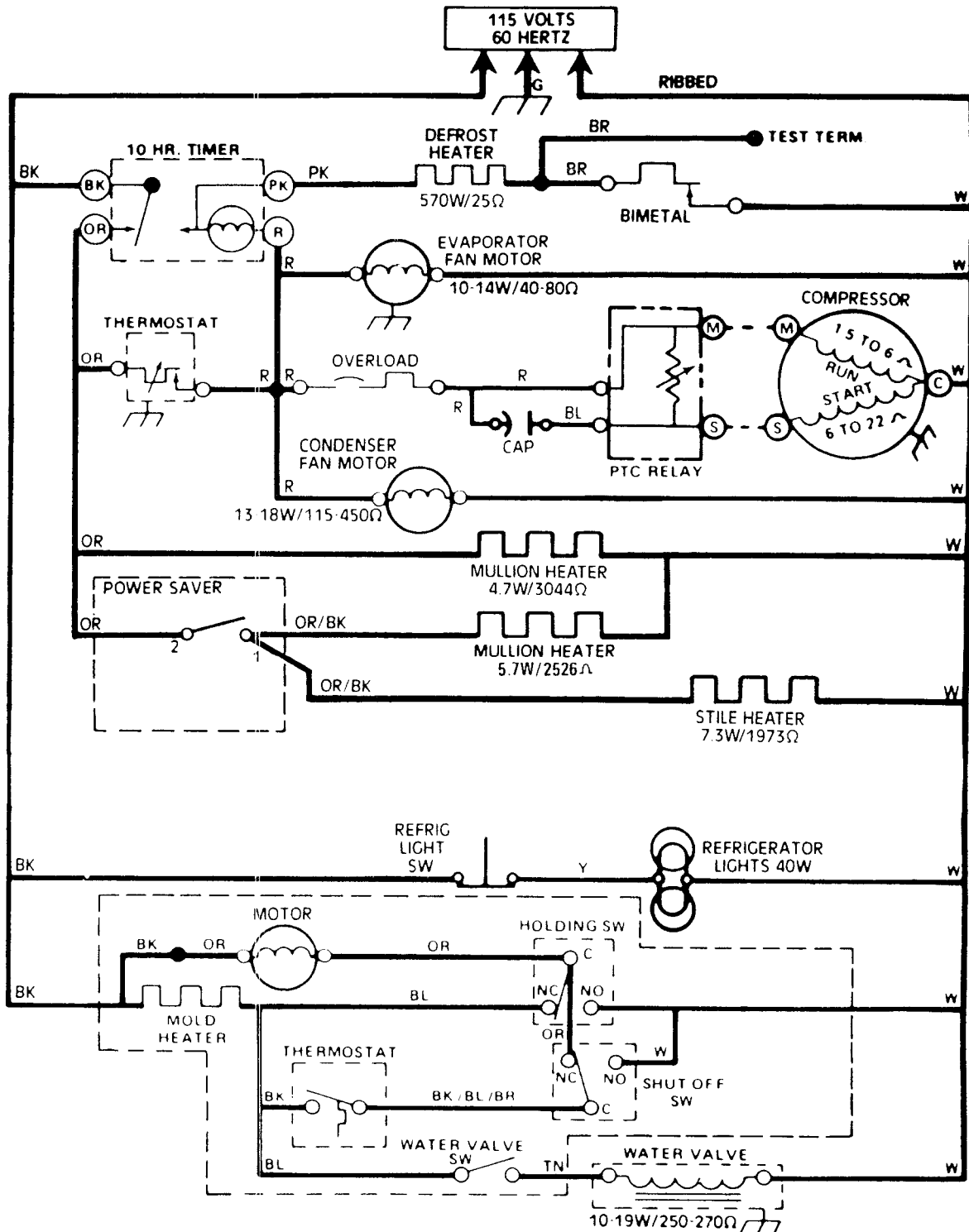

Remember when trying to diagnosis problems with refrigerators it is important to eliminate the electrical system as a problem prior to assuming a problem with the sealed system.

When diagnosing a faulty refrigerator - if the evaporator or condenser fan are running then several items in the circuit can be eliminated; the thermostat is working, you have voltage to the refrigerator, and the defrost timer is in the refrigeration mode.

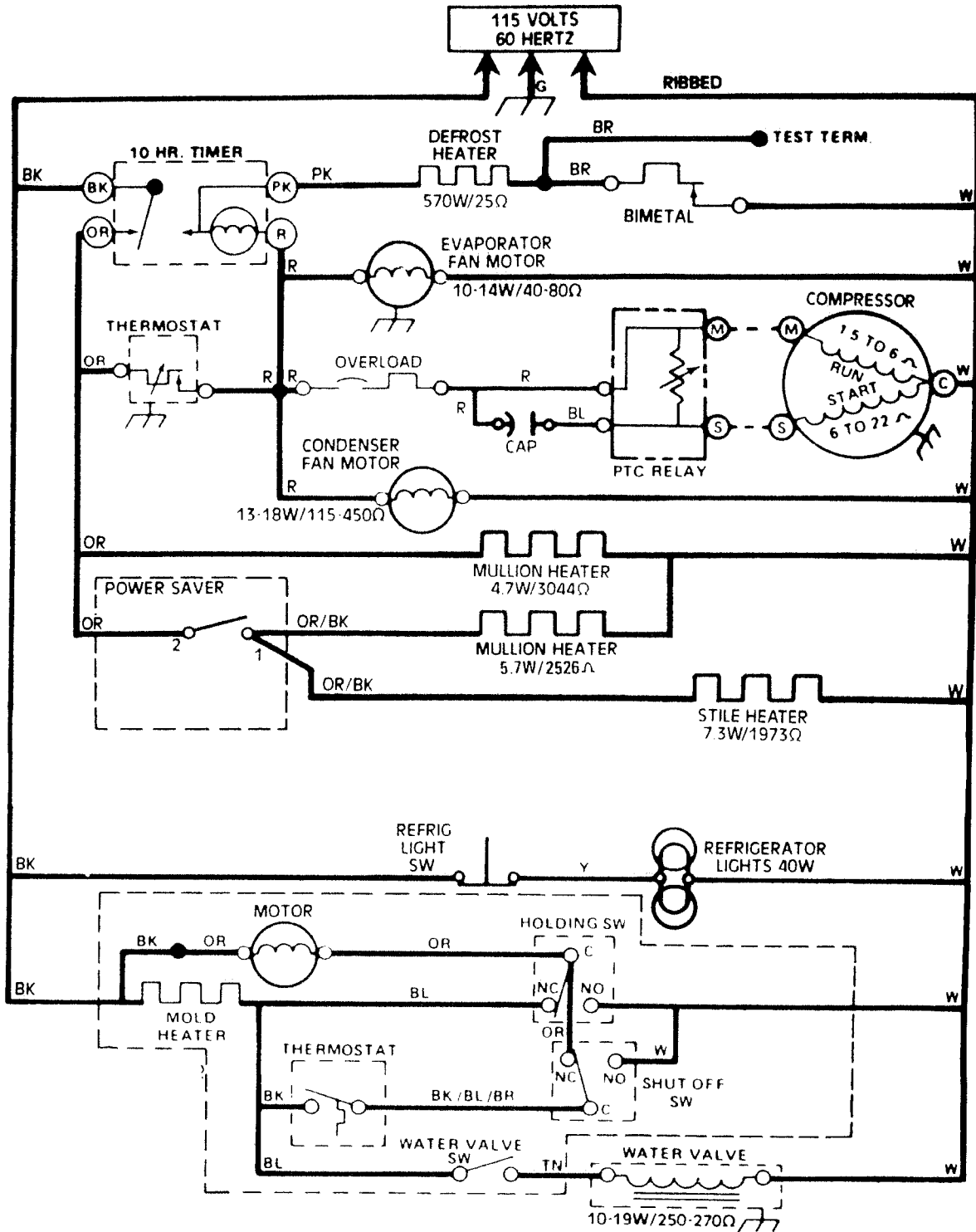



**“SECTION 5”  
Basic Refrigeration Diagnosis**

**DIAGNOSIS SUMMARY SHEET**

	1	2	3	4	5
Evaporator Inlet Temperature					
Refrigerator Storage Temperature					
Condenser Inlet Temperature					
Condenser Outlet Temperature					
Suction Line Temperature					
Unusual Compressor Noises (Y/N)					
Unusual Refrigerant Noises (Y/N)					
Wattage Reading					
Amperage					
Frost Pattern (F-Full P-Partial N-None)					
Low-side Pressure					
High-side Pressure					

**Sealed System Failure Types:**

1. No Failure
2. Leak or Low Charge
3. Partial Restriction
4. Complete Restriction
5. Overcharge

# DIAGNOSIS SUMMARY SHEET

	1	2	3	4	5
Evaporator Inlet Temperature	3	4	8	80	3
Refrigerator Storage Temperature	39	53	62	73	38
Condenser Inlet Temperature	140	109	78	90	137
Condenser Outlet Temperature	96	92	78	80	90
Suction Line Temperature	83	79	72	75	27
Unusual Compressor Noises (Y/N)	N	N	N	N	Y
Unusual Refrigerant Noises (Y/N)	N	Y	Y	N	N
Wattage Reading	178	165	117	91	260
Amperage	1.86	1.77	1.47	1.35	2.39
Frost Pattern (F-Full P-Partial N-None)	F	P	P	N	F
Low-side Pressure	1#	8" VAC	24" VAC	28" VAC	11#
High-side Pressure	121	105	93	83	180

**Sealed System Failure Types:**

1. No Failure
2. Leak or Low Charge
3. Partial Restriction
4. Complete Restriction
5. Overcharge

Diagnosing a sealed system failure is probably more complex than all other appliance diagnosis. In this section we will be covering the sealed system diagnosis. It is important to remember that other factors should be ruled out prior to assuming a sealed system failure.

There are times when suspected refrigerator failure may not be caused by a sealed system.

As with other appliances, customers have major impact on the performance of the product. Listen to them carefully and try to determine if they are using the product properly.

Diagnosing refrigerators is difficult because they have the same types of electrical and mechanical failures as other appliances. Therefore, be sure you check switches, loads, and doors, prior to assuming a sealed system failure.

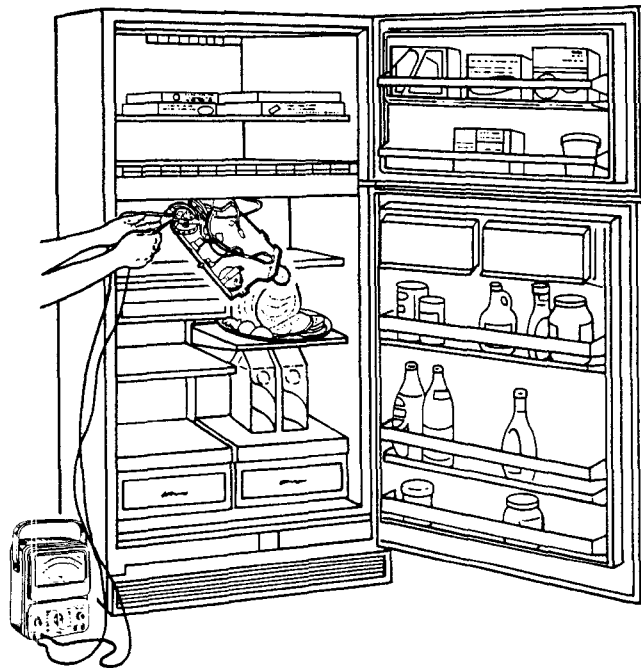

A major cause of refrigeration problems is the environment. Notice the environment. Are there any major heat sources such as direct sunlight on the refrigerator?

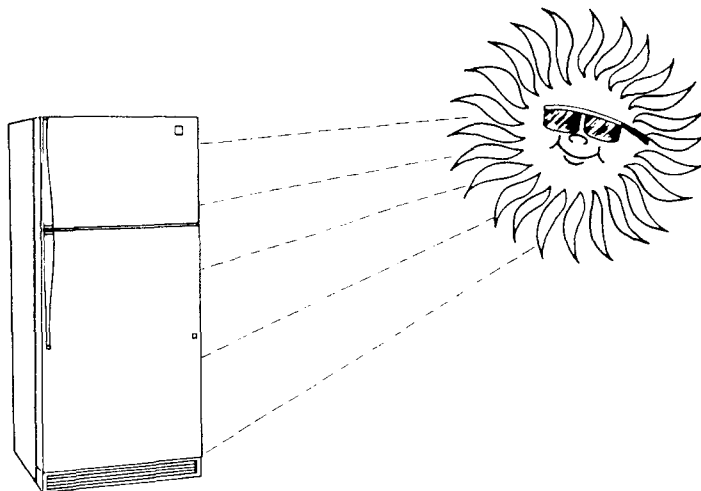

The environment has a direct relationship on how well the refrigerator can disperse the heat load.

Another very important source of problems could be air flow. The evaporator fan located inside the refrigerator on top-freezer models circulates air inside the refrigerator. The fan is used to draw air from the bottom of the freezer section and the top of the fresh food section. It pulls this air across the evaporator to remove its heat.

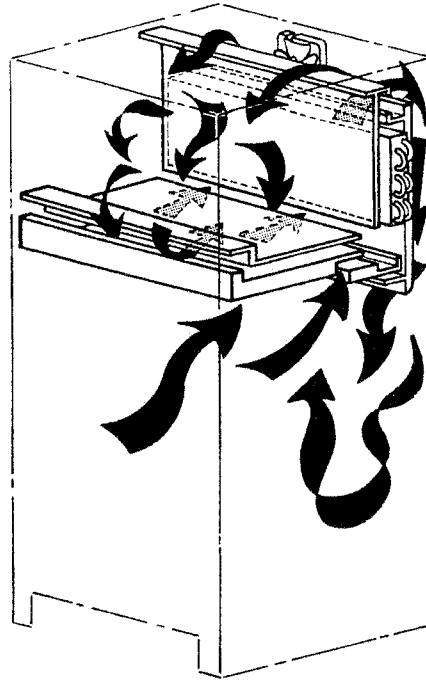

After being cooled the air is vented back to the top of the fresh food section and the top of the freezer section. This air flow inside the refrigerator is very important. Without it only the food very close to the evaporator would have the heat removed. It is important to be sure this air-flow is working properly prior to assuming a refrigerator has a sealed system failure.

Some refrigerators also have a condenser fan. The condenser fan pulls the room temperature air across the condenser coils and across the compressor. It then pushes the heat out to the front of the refrigerator and discharges the heated air to the room.

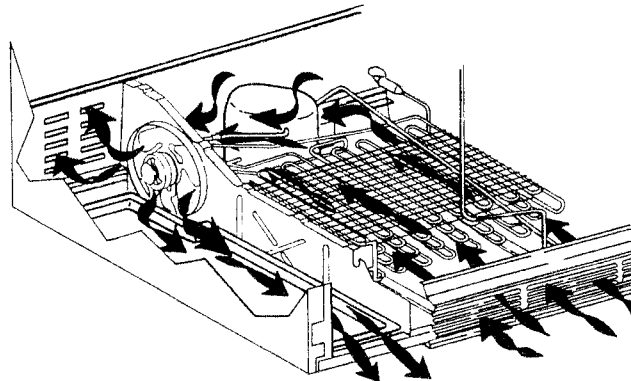

It is important that this type of system be cleaned regularly to ensure proper heat extraction.

It is also important that the fiber board on the back of the refrigerator be in place in order for proper airflow to occur. Without the fiberboard in place, the condenser and compressor will not cool properly causing the refrigerator to work harder and possibly damage the compressor through overheating. The fiberboard contains some small holes to allow some hot air to circulate up the back of the refrigerator to prevent condensation build up.

The most important tool is sealed system diagnosis is understanding what normal operation should be. In this section of the video we showed five refrigerators. Sealed system problems were in four of the five refrigerators. The demonstration was done in a room with a 75° ambient temperature.

### NORMAL

The first refrigerator was a normally operating refrigerator. Let's review the readings as we saw them on the refrigerators. These readings can be used by the technician to isolate sealed system failures.

	1
Evaporator Inlet Temperature	3

First of all, the evaporator inlet temperature was 3°F. If you take the temperature of the inlet and outlet of the evaporator just before the thermostats opens there will be less than 5°F difference with the inlet being slightly cooler. This difference is called "Super Heat".

Refrigerator Storage Temperature	39
----------------------------------	----

The refrigerator storage temperature was 38 degrees. As the system removes heat from the inside of the insulated box a thermostat responds to the temperature drop in the refrigerator section. When the preset temperature is reached the thermostat opens and turns off the compressor which in turn shuts down the sealed system. When the temperature rises inside the insulated box to the point that the thermostat closes again, the compressor will kick in, and the sealed system will begin to operate again.

These readings were from a normal refrigerator that had been operating for some time. If all the other systems are working properly, the refrigeration system will remove enough heat to maintain the freezer section at 0-8°F and the fresh food section at 35-40°F.

<b>Condenser Inlet Temperature</b>	<b>140</b>
<b>Condenser Outlet Temperature</b>	<b>96</b>

Most of the condenser will contain high pressure gas. Only the last pass or two of the condenser will contain high pressure liquid. Part or all of the condenser will be warmer than room temperature if the system is subjected to a sufficient heat load. This warmth is hard to detect when the condenser temperature is less than body temperature.

<b>Suction Line Temperature</b>	<b>83</b>
---------------------------------	-----------

This reading will vary based on its proximity to the capillary tube. If you put your hand on the suction line near the compressor when the system kicks in you will feel a noticeable drop in temperature. The part of the suction line close to the compressor will be cooler than the other end of the suction line. You might even notice momentary frosting of the suction line.

<b>Unusual Compressor Noises (Y/N)</b>	<b>N</b>
<b>Unusual Refrigerant Noises (Y/N)</b>	<b>N</b>

The compressor noise is normal.

There isn't any unusual refrigerant noise either.

<b>Wattage Reading</b>	<b>178</b>
------------------------	------------

Even though we would prefer to read wattage the refrigerator would need to be unplugged in order to connect the meter. This would force the system to be disrupted and could change the state of the failure.

<b>Amperage</b>	<b>1.86</b>
-----------------	-------------

Amperage readings will also tell you how the system is performing.. The amp reading of this refrigerator is 1.86 amps.

<b>Frost Pattern</b> (F-Full P-Partial N-None)	<b>F</b>
---	----------

The frost pattern should be full. Two-thirds of the refrigerant in the evaporator is in liquid form. There is no practical way to measure the liquid levels in various parts of the system. The system is designed to have liquid present throughout the evaporator and the accumulator if it has one. This means that a system that has been operating for some time should have a thin layer of hard frost on all passes of the evaporator tubing and the accumulator. This is not the case when a normal system that has been just turned on, just came out of defrost, or if there is an unusually large heat load inside the refrigerator.

<b>Low-side Pressure</b>	<b>1#</b>
<b>High-side Pressure</b>	<b>121</b>

The use of guages generally isn't suggested because the system would have to entered to connect them. For comparison purposes we are using them.

While operating the low pressure side of the system will have a pressure of 0 - 5 PSI. The high side will have between 75 and 150 PSI. These pressures vary because of changes in usage and room temperature.

After the system shuts down pressures throughout the system will gradually equalize. How fast pressure equalizes will depend on the diameter and length of the capillary tube. The inside diameter may range from .03 to .08 inches and the length may range from a few inches to six- eight feet.

Beware of what you read as normal. There are several factors involved in the readings you have obtained, such as room temperature or length of compressor run time. Remember, the warmer the room the more difficult for the refrigerant to give up its heat to the outside air.

## LEAK OR LOW CHARGE

Let's look at a defective refrigerator. This second refrigerator had a leak or a low charge. This condition may have been caused by a small leak in the system or use of incorrect charging method. Other than a compressor failure, leaks are the most common sealed system failure. A low charge in the refrigerator is very unlikely unless the refrigerator sealed system was recently entered.

Excessive heat loads may be a leak or low charge look alike. Occasionally a light bulb left on because a door isn't properly aligned could cause this symptom.

High side leaks will show up more quickly than low side leaks. Leaks will generally be found at access valves or joints if the product was recently repaired.

This is where leaks are most commonly found.

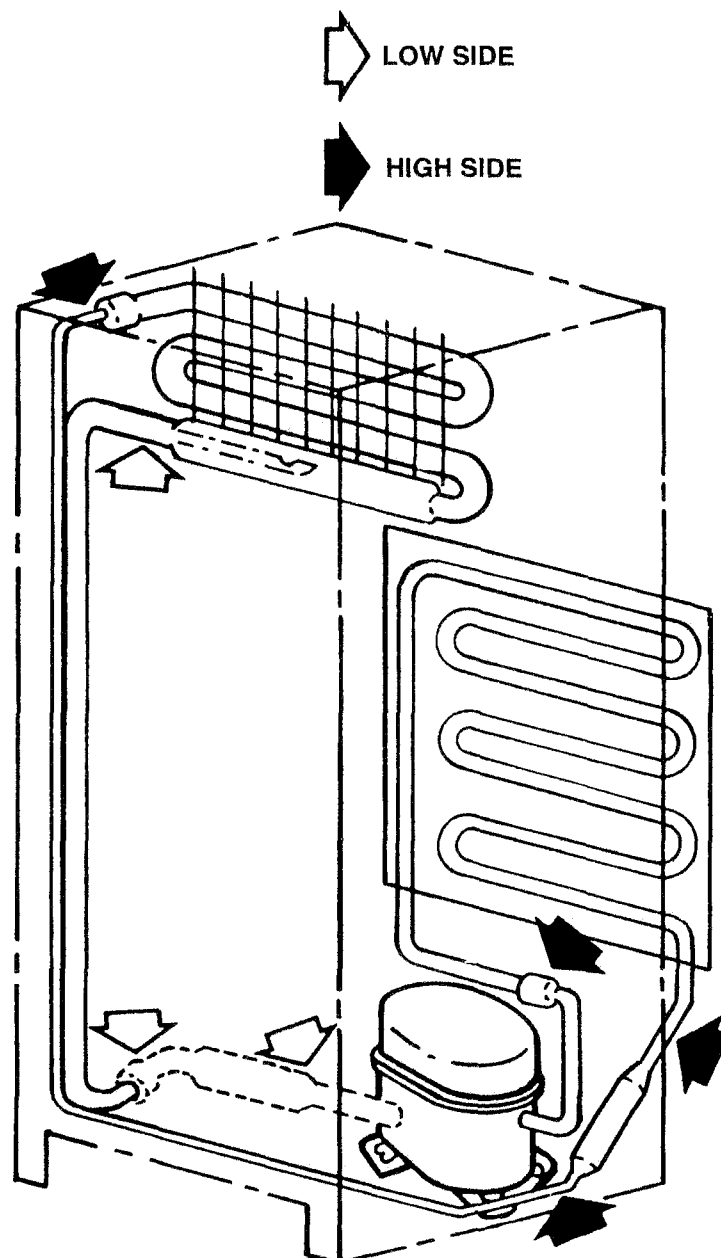



Lets look at our readings for this refrigerator with a low charge.

## DIAGNOSIS SUMMARY SHEET

	1	2
<b>Evaporator Inlet Temperature</b>	3	4
<b>Refrigerator Storage Temperature</b>	39	53

Temperature in the storage compartment will be higher because there is less liquid refrigerant available for heat absorption. However, it should be noted that low side leaks could leave you with near normal freezer temperatures. Cycle defrost models may have freezer temperatures lower than normal.

<b>Condenser Inlet Temperature</b>	140	109
------------------------------------	-----	-----

The temperature of the condenser will be cooler than a normal operating condenser.

<b>Condenser Outlet Temperature</b>	96	92
<b>Suction Line Temperature</b>	83	79
<b>Unusual Compressor Noises (Y/N)</b>	N	N
<b>Unusual Refrigerant Noises (Y/N)</b>	N	Y

It is possible to hear a slight hissing in the evaporator inlet. This depends on the amount of refrigerant that remains in the system.

<b>Wattage Reading</b>	178	165
<b>Amperage</b>	1.86	1.77

Because there is less refrigerant in the system the wattage and amp readings will be lower because the motor will not have to work as hard because there is less refrigerant in the system.

<b>Frost Pattern (F-Full P-Partial N-None)</b>	F	P
--	---	---

The frost pattern could be anywhere from full to partial. This would depend on the amount of refrigerant that remains in the system.

Low-side Pressure	1#	8" VAC
High-side Pressure	121	105

**Sealed System Failure Types:**

1. No Failure
2. Leak or Low Charge

One other thing to remember, temporary access valves will always leak. It is acceptable to use them in purging refrigerant from the sealed system but they must then be removed. The replacement valve must be an approved brazed access valve using Teflon tape to seal the cap.

### PARTIAL RESTRICTION

Our next refrigerator has a partial restriction. This could be caused by one of the following problems.

A partially kinked or smashed tube,  
partially blocked tubing, or  
a partially blocked dryer screen.

Lets see what the readings are on this refrigerator with a partial restriction.

### DIAGNOSIS SUMMARY SHEET

	1	2	3
Evaporator Inlet Temperature	3	4	8
Refrigerator Storage Temperature	39	53	62

Notice the storage temperature ranges are high for refrigerators 2 and 3. It is very possible for storage temperatures to be near normal for partial restrictions, low charges or early detected leaks. Remember the amount of liquid refrigerant reaching the evaporator determines the amount of heat that can be removed from the refrigerator.

Condenser Inlet Temperature	140	109	78
Condenser Outlet Temperature	96	92	78
Suction Line Temperature	83	79	72
Unusual Compressor Noises (Y/N)	N	N	N
Unusual Refrigerant Noises (Y/N)	N	Y	Y
Wattage Reading	178	165	117
Amperage	1.86	1.77	1.47
Frost Pattern (F-Full P-Partial N-None)	F	P	P
Low-side Pressure	1#	8" VAC	24" VAC
High-side Pressure	121	105	93

**Sealed System Failure Types:**

1. No Failure
2. Leak or Low Charge
3. Partial Restriction
4. Complete Restriction
5. Overcharge

The condenser outlet temperature, wattage reading, amperage reading, and low side pressure would indicate that the restriction is almost complete.

Partial restrictions can be similar in appearance to leaks and low charges. Once you have determined a partial restriction you must look for the area of the restriction.

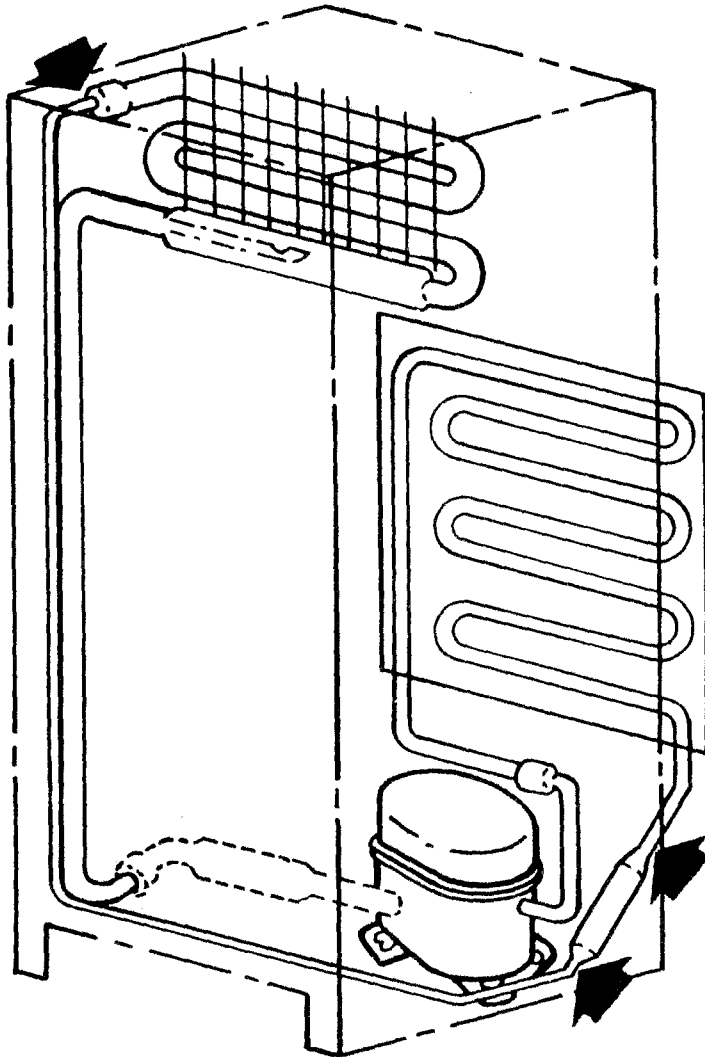

If the product has been recently repaired then the recently brazed joints could be the culprit. The capillary tube is often the place of concern. You may have a frost build-up in the position of a partial restriction or at least feel a temperature difference on both sides of the restriction. If the product was just delivered then look for signs of damage. It is possible that the tubing was smashed during production or delivery. If the product has been in place for a long period of time without a recent repair the probable failure would be a clogged drier..

## COMPLETE RESTRICTION

Our next refrigerator has a complete restriction. Although the compressor is running there is no refrigerant flow throughout the entire sealed system. This condition generally results from the following failures:

1. Kinked or Crushed Tubing or Badly Brazed Joints
2. An Inefficient Compressor
3. A Complete Moisture Restriction
4. A Completely Blocked Filter Drier

Let's see what our readings would be on our fourth refrigerator.

## DIAGNOSIS SUMMARY SHEET

	1	2	3	4
Evaporator Inlet Temperature	3	4	8	80
Refrigerator Storage Temperature	39	53	62	73

Since there is no liquid refrigerant getting back to the evaporator, there can be no heat removal. In fact, the heat generated by the evaporator fan motor will actually heat the refrigerator interior.

Refrigerator Storage Temperature	39	53	62	73
Condenser Inlet Temperature	140	109	78	90
Condenser Outlet Temperature	96	92	78	80
Suction Line Temperature	83	79	72	75
Unusual Compressor Noises (Y,N)	N	N	N	N
Unusual Refrigerant Noises (Y,N)	N	Y	Y	N

We say there is no unusual refrigerant noises. In reality, there is a very different refrigerant noise. That is the lack of noise. You will have no liquid refrigerant spray noise at the cap tube outlet.

Wattage Reading	178	165	117	91
Amperage	1.86	1.77	1.47	1.35

The workload on the compressor is restricted to the turning of the pump and the work it does against the high pressure of the condenser. There would be nothing in the chamber of the pump and, therefore, wattage and amperage would be low. If you use gauges you would find the vacuum deeper than with a partial restriction.

Frost Pattern (F-Full P-Partial N-None)	F	P	P	N
Low-side Pressure	1#	8" VAC	24" VAC	28" VAC
High-side Pressure	121	105	93	83

Begin by eliminating the possibility of physical damage to the sealed system. If the product has been recently repaired then the brazed joints could be the culprit. If the product has recently been delivered look for signs of damage. It is possible that the tubing was smashed during production or delivery.

If the product has been in place for a long period of time without a recent repair the probable failures would be an inefficient compressor, a complete moisture restriction or a filter drier or capillary tube completely clogged with foreign material.

An inefficient compressor will present the same symptoms as a complete restriction in that the compressor will run but no refrigerant will circulate through the sealed system. If in any sealed system diagnosis I were to use a set of gauges, it would be here. An inefficient compressor would not give you a deep vacuum on the low side. All other readings would be similar.

While the compressor is running listen for refrigerant noise and look for a frost pattern at the inlet to the evaporator. If neither of these occur, shut off the compressor and wait three minutes for the PTC relay to reset. Then turn on the compressor. If it starts, the compressor is probably inefficient. If it does not start, the system is most likely restricted.

Once you have eliminated both physical damage to the tubing and an inefficient compressor, you can then assume there is a complete restriction. Begin by looking for the area of the restriction. A complete restriction will almost always have all the refrigerant in the high side.

A complete moisture restriction will most likely be located at the inlet to the evaporator. You may be able to detect this by noticing the absence of a frost pattern on the evaporator while the compressor is running. Turn off the compressor and listen for a hiss at the inlet to the evaporator. If there is none, using a heat gun, heat up the inlet. Turn on the compressor and listen for refrigerant flow noise or look for the re-appearance of a frost pattern to verify that the moisture restriction has cleared.

If refrigerant noise or frosting still does not occur at the evaporator inlet you can be reasonably certain that the filter drier or capillary tube is completely clogged with foreign material and should be replaced. Follow the sweep procedures and evacuate the system and replace the filter drier. Recharge the system with 4 ounces of refrigerant and sweep the system to determine that the restriction has been corrected.

# OVERCHARGE

An overcharge condition could be caused by an incorrect charging method being used or adding an unnecessary charge to a system where none is required. An overcharge is very uncommon. The primary indicator that you have an overcharge is sweat or frost on the suction line.

Now let's look at our readings of an overcharged refrigerator.

## DIAGNOSIS SUMMARY SHEET

	1	2	3	4	5
Evaporator Inlet Temperature	3	4	8	80	3
Refrigerator Storage Temperature	39	53	62	73	38
Condenser Inlet Temperature	140	109	78	90	137
Condenser Outlet Temperature	96	92	78	80	90
Suction Line Temperature	83	79	72	75	27

The primary indicators are the refrigerator storage temperatures and the tell tale sweating on the suction line. The evaporator will be completely frosted.

Unusual Compressor Noises (Y,N)	N	N	N	N	Y
Unusual Refrigerant Noises (Y,N)	N	Y	Y	N	N
Wattage Reading	178	165	117	91	260
Amperage	1.86	1.77	1.47	1.35	2.39

The compressor wattage and temperature will be higher than normal and the compressor will be quite noisy. If the system is greatly overcharged and allowed to operate the compressor will probably be damaged when it tries to pump liquid refrigerant.

If you accidentally overcharge a system, correct the charge before you allow the system to operate.

The repair for an overcharge is to follow the sweep procedure. Evacuate the system, sweep the system and charge the refrigerator with the correct charge. It is not likely, but sometimes you may come across an overcharged system.

There are many factors in refrigerator complaints that should be eliminated before the sealed system should be suspected. The first is customer usage problems, then electrical and mechanical problems and finally environment problems.

All these factors can confuse the diagnosis of sealed system failure. There are only three kinds of failures that can happen in a sealed system:

Restrictions to the flow of refrigerant in a sealed system

Improper refrigerant charge

Compressor failure

**REMEMBER, BEFORE CONDEMNING THE SEALED SYSTEM, RULE OUT ITEMS THAT HAVE CAUSED THE FAILURE OR ARE THE FAILURE.**

This concludes the workbook portion of the "Sealed System Diagnosis" program. With any luck your instructor has several products for your "Bugged Pleasure." Good Luck.



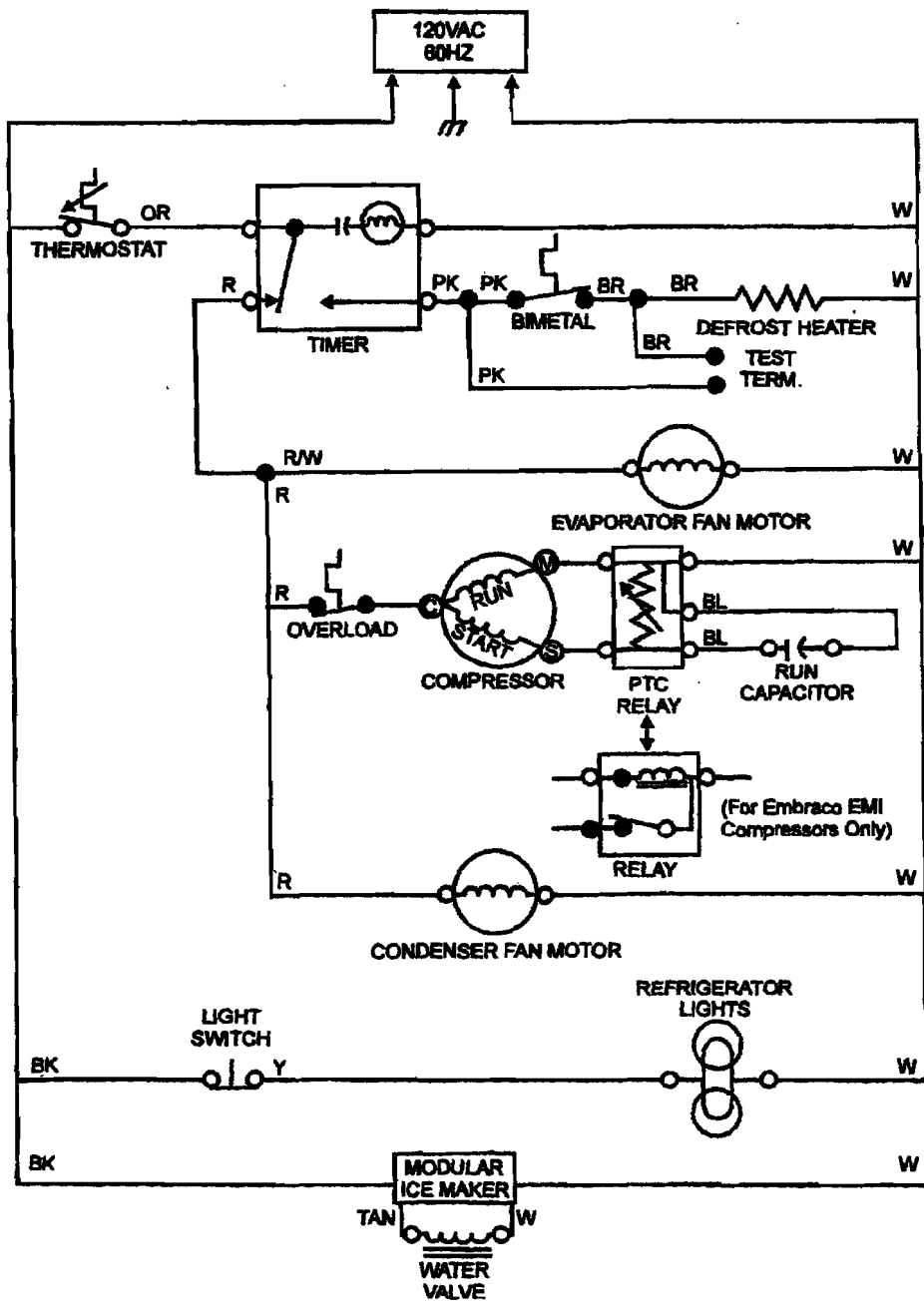

# **NOTES**

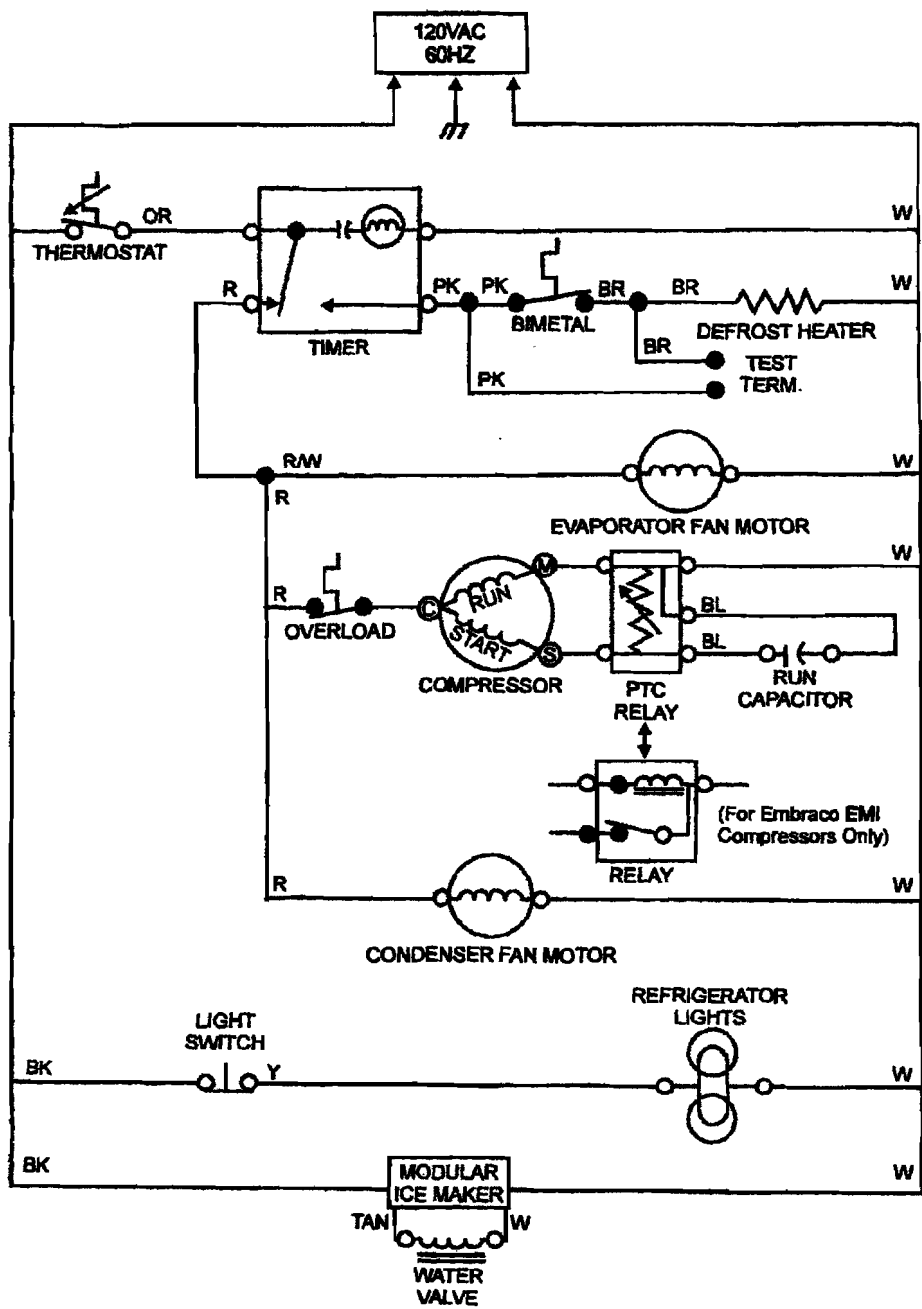

# **NOTES**

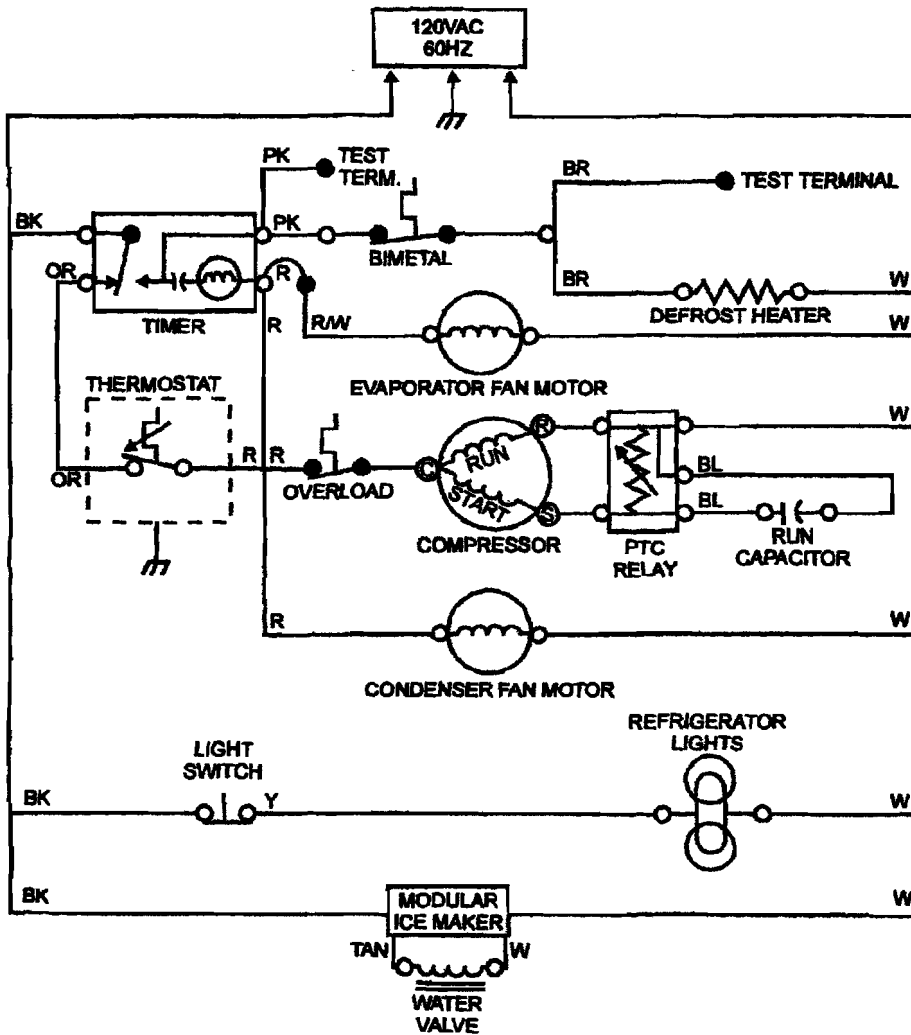

# **NOTES**

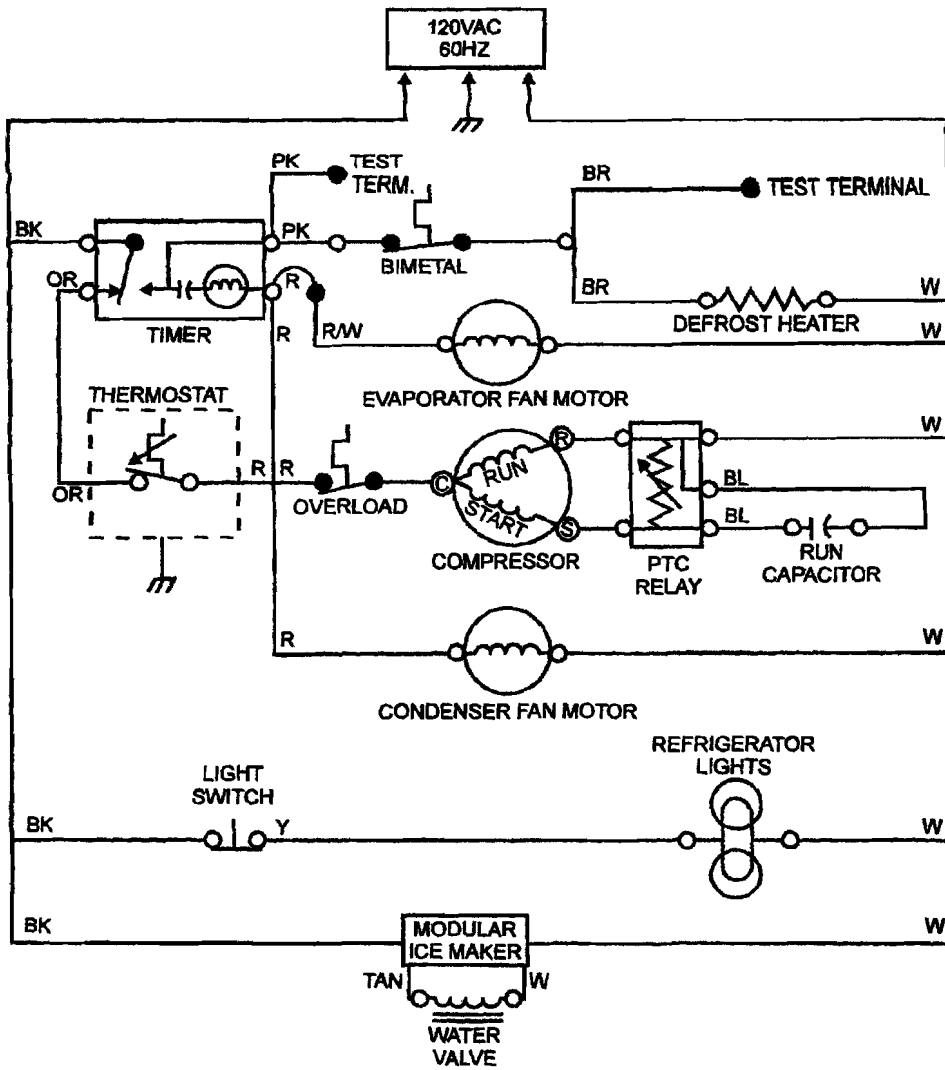

# **NOTES**



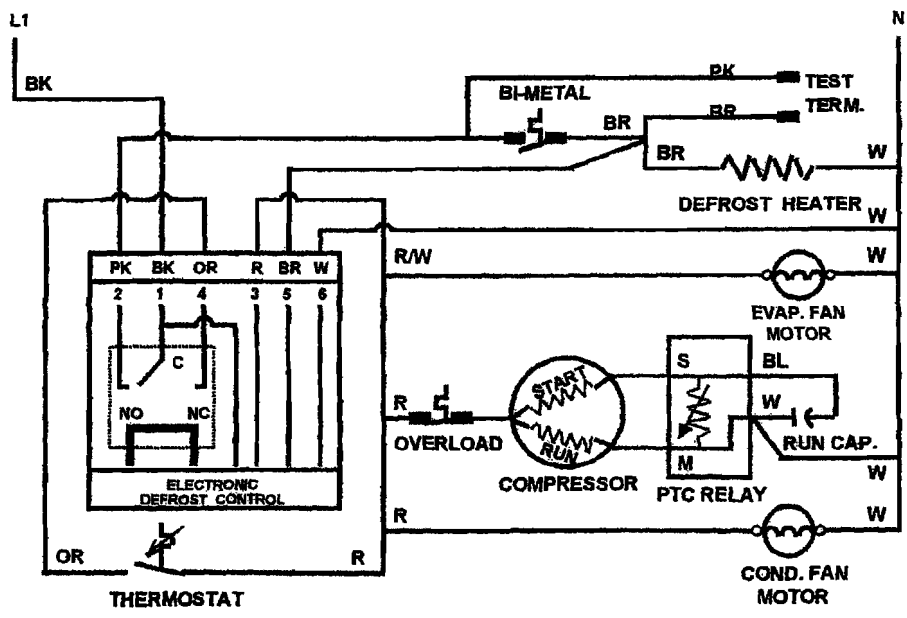

# **NOTES**

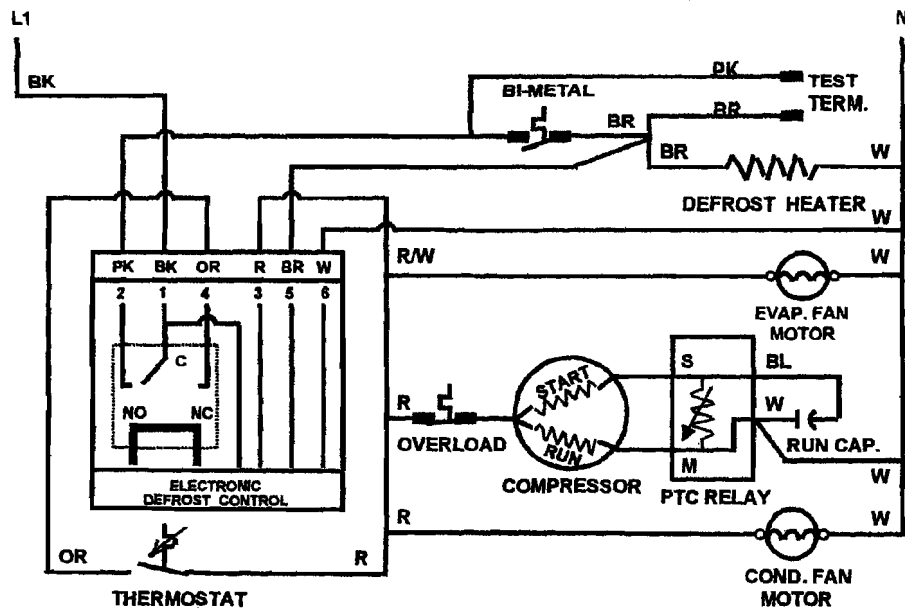

# **NOTES**





Making your world a little easier.

Automatic Washers, Clothes Dryers, Freezers, Refrigerator-Freezers, Ice Makers, Dishwashers, Built-In Ovens and Surface Units, Ranges, Microwave Ovens, Co

