



Preferred Service

# Service Manual

This manual is to be used by qualified appliance technicians only. Viking does not assume any responsibility for property damage or personal injury for improper service procedures done by an unqualified person.

## Built-In Side-by-Side Refrigerator/ Freezer

This Base Manual covers general and specific information including, but not limited to the following models:

**VCSB542/542D**

**VCSB548/548D**

**VISB542/542D**

**VISB548/548D**

**DDSB542/542D**

**DFSB542/542D**

**DDSB548/548D**

**DFSB548/548D**



# Table of Contents

<i>Description</i>	<i>Page</i>
Important Information .....	3
Safety Information .....	3
 <b>WARRANTY INFORMATION</b>	
Warranty Information .....	4
Warranty Service Information .....	5
 <b>GENERAL INFORMATION</b>	
Specifications .....	6
Warnings.....	14
Model – Serial Number Matrix .....	15
 <b>OPERATION</b>	
Settings and Functions .....	16
Automatic Ice Maker .....	18
Door Stop Adjustment .....	18
Light Bulb .....	18
Door Hinge Adjustment .....	19
Height Adjustment .....	20
 <b>DIAGNOSTICS</b>	
Display Panel Operation.....	21
Program Modes.....	22
Control Panel.....	22
Mode A Functions .....	23
Reading Temperature Display .....	23
Freezer Thermistor Temperature .....	24
Optional Conventional Defrost .....	24
VCC Compressor Frequency .....	25
Refrigerator Cut-In/Cut-Out Temperature Differential .....	25
Freezer Cut-In/Out Temperature Differential .....	26
Mode B Functions .....	27
Automatic Keyboard Functions.....	27
Door Alarm Delay.....	28
Max Refrigerator Run Time Duration.....	29
Max Freezer Run Time Duration.....	30
Temperature Offset Calibration.....	31
Setting Refrigerator Temperature Offset.....	31
Setting Freezer Temperature Offset.....	32
Defrost Mode Selection.....	33
Forced Defrost.....	33
Forced Compressor Start .....	33
Exiting Program Mode .....	34
Special Features .....	34
Forced Defrost Start .....	34
Forced Compressor Start .....	34
Open Thermistor Detect .....	34
Enter Showroom Mode .....	35
Exit Showroom Mode .....	35
Sabbath Mode Feature for Sabbath Observance.....	36
Enter Sabbath Mode .....	36
Power Loss.....	36
Exit Sabbath Mode.....	36
Power Disconnect Switch .....	37
Power Up Alarm .....	37
Door Open Alarm.....	37
High Temperature Alarm .....	37
Thermistor Alarm.....	38

<i>Description</i>	<i>Page</i>
Temperature Control Operation.....	38
Refrigerator and Freezer Thermistor (NTC).....	38
 <b>SERVICE DIAGNOSTICS AND PROCEDURES</b>	
VCC3 Diagnostic codes.....	40
Flashing Cycles.....	40
Diagnostic Procedures.....	40
Parts Location–Control Panel .....	42
Upper Grill Assembly.....	43
Control Panel.....	43
Overlay Switch.....	44
High Voltage Board .....	45
Low Voltage Board .....	45
Component Testing–High Voltage Board.....	46
Component Testing–Low Voltage Board.....	47
Power Disconnect Switch .....	48
Inverter .....	48
Condenser Fan .....	49
Parts Location–Refrigerator Compartment.....	50
Light Assembly .....	51
Fresh Food Fan Assembly .....	51
Interior Light.....	52
Fresh Food Thermistor .....	53
Plasma Cluster.....	54
Water Filter.....	54
Parts Location–Freezer Compartment Non-Dispenser....	55
Parts Location–Freezer Compartment Dispenser.....	56
Ice maker .....	57
Component Testing–Ice Maker .....	58
Thermal Cut Out (TCO).....	59
Auger Motor.....	60
Freezer Evaporator Fan .....	61
Freezer Thermistor .....	63
Defrost Heater.....	63
Defrost Terminator.....	65
Float Switch .....	66
Water Valve Non-Dispenser .....	66
Dual Water Valve System Dispenser.....	66
Drain Pan Heater .....	67
Parts Location Dispenser .....	68
Dispenser Assembly .....	69
Dispenser Bezel.....	69
Crushed/Cubed Switch .....	70
Ice and Water Paddles.....	70
Cavity Cover Assembly.....	71
Ice Dispenser Module Assembly .....	72
Ice Door Switch .....	73
Water Switch.....	73
Child Lock Switch .....	74
Dispenser Light Socket.....	74
Dispenser Heater.....	75
Troubleshooting Guide.....	76
 <b>WIRING DIAGRAMS</b>	
Schematic Non Dispenser Model.....	79
Schematic Dispenser Model.....	80
Schematic Dispenser .....	81
Wiring and Component testing–	
High Voltage Board.....	82
Wiring Diagram Dispenser Model.....	83
Wiring Diagram Non-Dispenser Model.....	84

## SAVE THESE INSTRUCTIONS

REVIEW ALL SERVICE INFORMATION IN THE APPROPRIATE SERVICE MANUAL AND TECHNICAL SHEETS BEFORE BEGINNING REPAIRS.

Pride and workmanship go into every product to provide our customers with quality appliances. It is possible, however, that during the lifetime of a product, service may be required. Products should be serviced only by a qualified authorized service technician who is familiar with the safety procedures required to perform the repair and is equipped with the proper tools, parts, testing instruments, and the appropriate service manual.

### Safety Information

We have provided many important safety messages throughout this manual and on the appliance. **ALWAYS** read and obey all safety messages. This is a safety alert symbol.



This symbol alerts personnel to hazards that can kill or hurt you and others. All safety messages will be preceded by a safety alert symbol and the word "DANGER", "WARNING" or "CAUTION". These words mean:

<b>DANGER</b>
Immediate hazards which <b>WILL</b> result in severe personal injury or death.
<b>WARNING</b>
Hazards or unsafe practices which <b>COULD</b> result in severe personal injury or death.
<b>CAUTION</b>
Hazards or unsafe practices which <b>COULD</b> result in minor personal injury, product or property damage.

All safety messages will identify the hazard, tell you how to reduce the chance of injury, and inform you what can happen if the instructions are not followed.

<b>WARNING</b>
To avoid risk of serious injury or death, repairs should not be attempted by unauthorized personnel.

<b>CAUTION</b>
VIKING will not be responsible for any injury or property damage from improper service procedures. If performing service on your own product, you must assume responsibility for any personal injury or property damage which may result.

To locate an authorized service agent, call:  
Viking Customer Service  
Phone No. 1-888-845-4641

Address your written correspondence to:  
Viking Preferred Service  
1803 HWY 82 West  
Greenwood, MS 38930

## Side-By-Side

### Two Year Full Warranty

Side-By-Side refrigerators and all of their components and accessories, except as detailed below\*, are warranted to be free from defects in material or workmanship under normal household use for a period of two (2) years from the date of original retail purchase. Viking Range Corporation, warrantor, agrees to repair or replace, at its option, any part which fails or is found to be defective during the warranty period.

\*Glass (including light bulbs), painted and decorative items are warranted to be free from defective materials or workmanship for a period of ninety (90) days from the date of original retail purchase. ANY DEFECTS MUST BE REPORTED TO THE SELLING DEALER WITHIN NINETY (90) DAYS FROM DATE OF ORIGINAL RETAIL PURCHASE.

Viking Range Corporation uses the most up-to-date processes and best materials available to produce all color finishes. However, slight color variation may be noticed because of the inherent differences in painted parts and porcelain parts as well as differences in kitchen lighting, product locations, and other factors.

### Six Year Full Warranty

Any sealed refrigeration system component, as listed below, or any automatic ice maker is warranted to be free from defective materials or workmanship in normal household use during the third through the sixth year from the date of original retail purchase. Viking Range Corporation, warrantor, agrees to repair or replace, at its option, any part which fails or is found to be defective during the warranty period.

Sealed Refrigeration System Components:  
Compressor, Evaporator,  
Condenser, Connecting Tubing, Dryer/Strainer

### Twelve Year Limited Warranty

Any sealed refrigeration system component, as listed above, which fails due to defective materials or workmanship in normal household use during the seventh through the twelfth year from the date of original retail purchase will be repaired or replaced, free of charge for the part itself, with the owner paying all other costs, including labor.

### Ninety (90) Day Residential Plus Warranty

This warranty applies to applications where use of the product extends beyond normal residential use. Examples are, but not limited to, bed and breakfasts, fire stations, private clubs, churches, etc. This warranty excludes all commercial locations such as restaurants, food service locations and institutional food service locations.

This warranty extends to the original purchaser of the product warranted hereunder and to each transferee owner of the product during the term of the warranty.

This warranty shall apply to products purchased and located in the United States and Canada. Products must be purchased in the country where service is requested. Warranty labor shall be performed by an authorized Viking Range Corporation service agency or representative. Warranty shall not apply to damage resulting from abuse, accident, natural disaster, loss of electrical power to the product for any reason, alteration, improper installation, improper operation or repair or service to the product by anyone other than an authorized Viking Range Corporation service agency or representative. Warranty shall not apply to damage resulting from indoor units being used in outdoor situations. This warranty does not apply to commercial usage. This warranty does not cover any food or medicine loss due to product failure. Warrantor is not responsible for consequential or incidental damage whether arising out of breach of warranty, breach of contract, or otherwise. Some jurisdictions do not allow the exclusion or limitation of incidental or consequential damages, so the above limitation or exclusion may not apply to you.

Owner shall be responsible for proper installation, providing normal care and maintenance, providing proof of purchase upon request, and making the appliance reasonably accessible for service. If the product or one of its component parts contains a defect or malfunction during the warranty period, after a reasonable number of attempts by the warrantor to remedy the defects or malfunctions, the owner is entitled to either a refund or replacement of the product or its component part or parts. Replacement of a component part includes its free installation. Warrantor's liability on any claim of any kind, with respect to the goods or services covered hereunder, shall in no case exceed the price of the goods or service or part there of which gives rise to the claim.

## VIKING RANGE CORPORATION

111 Front Street, Greenwood, Mississippi (MS) 38930 USA  
662-455-1200

For more product information, call 1-888-VIKING1 (845-4641), or visit our  
web site at <http://www.vikingrange.com>



### WARRANTY SERVICE

Under the terms of this warranty, service must be performed by a factory authorized Viking Range Corporation service agent or representative. Service will be provided during normal business hours, and labor performed at overtime or premium rates shall not be covered by this warranty. To obtain warranty service, contact the dealer from whom the product was purchased, an authorized Viking Range Corporation service agent, or Viking Range Corporation. Provide model and serial number and date of original purchase. For the name of your nearest authorized Viking Range Corporation service agency, call the dealer from whom the product was purchased or Viking Range Corporation. **IMPORTANT:** Retain proof of original purchase to establish warranty period.

The return of the Owner Registration Card is not a condition of warranty coverage. You should, however, return the Owner Registration Card so that Viking Range Corporation can contact you should any question of safety arise which could affect you.

Any implied warranties of merchantability and fitness applicable to the described halogen elements are limited in duration to the period of coverage of the applicable express written limited warranties set forth above. Some jurisdictions do not allow limitations on how long an implied warranty lasts, so the above limitation may not apply to you. This warranty gives you specific legal rights, and you may also have other rights which may vary from jurisdiction to jurisdiction.

**VIKING RANGE CORPORATION**  
111 Front Street • Greenwood, Mississippi 38930 USA  
(662) 455-1200  
[www.vikingrange.com](http://www.vikingrange.com)

**Specification subject to change without notice.**

Specifications\*

42" Professional Side-By-Side		
Description	VCSB542	VCSB542D
Overall width	42" (106.7 cm)	
Overall height from bottom	82-3/4" (210.2 cm) min. to 84-1/16" (213.5 cm) max.	
Overall depth from rear To front edge of side trim: To front of top grille: To front of handle end-cap	22-3/16" (56.4 cm) 24-11/16" (62.7 cm) 27-1/4" (69.2 cm)	
Electrical requirements	115 volt, 60 Hz, 15 amp dedicated circuit; 3-wire cord with grounded 3-prong plug attached to product	
Maximum amp usage	9.9 amps	
Inlet water requirements	1/4" copper tubing inlet waterline; minimum 20 psi; maximum 120 psi	1/4" copper tubing inlet waterline; minimum 35 psi; maximum 120 psi
Refrigerant Type	HFC-134a	
Refrigerant Charge	See rating label	
Approximate shipping weight	652 lbs. (293.4 kg)	676 lbs. (304.2 kg)

\*Go to [vikingrange.com](http://vikingrange.com) for latest specifications.

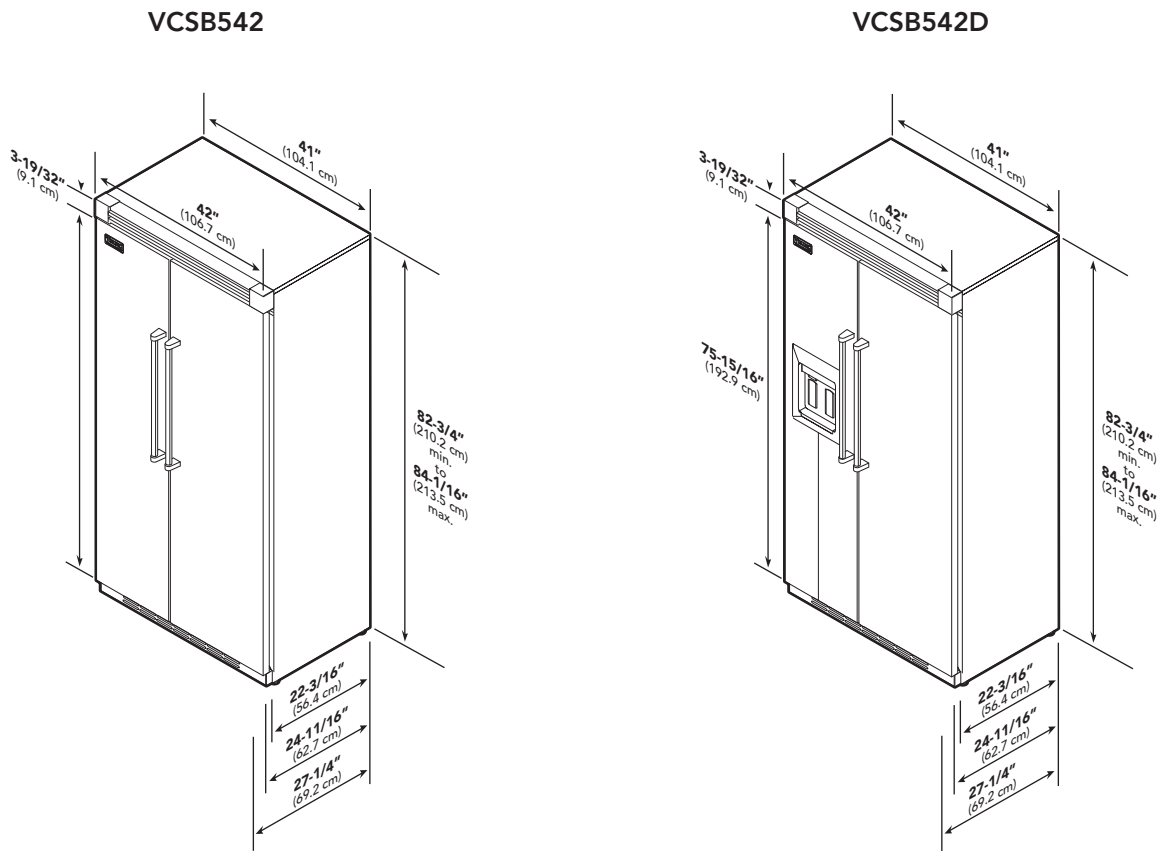

Specifications\*

42" Professional Side-By-Side		
Description	VISB542	VISB542D
Overall width	42" (106.7 cm)	
Overall height from bottom	82-3/4" (210.2 cm) min. to 84-1/16" (213.5 cm) max.	
Overall depth from rear		
To front edge of side trim:	23-3/8" (59.4 cm)	
To front of top grille:	24" (61.0 cm)	
To front of handle end-cap	26-1/2" (67.3 cm)	
Electrical requirements	115 volt, 60 Hz, 15 amp dedicated circuit; 3-wire cord with grounded 3-prong plug attached to product	
Maximum amp usage	9.9 amps	
Inlet water requirements	1/4" copper tubing inlet waterline; minimum 20 psi; maximum 120 psi	1/4" copper tubing inlet waterline; minimum 35 psi; maximum 120 psi
Refrigerant Type	HFC-134a	
Refrigerant Charge	See rating label	
Approximate shipping weight	625 lbs. (293.4 kg)	676 lbs. (304.2 kg)

\*Go to [vikingrange.com](http://vikingrange.com) for latest specifications.

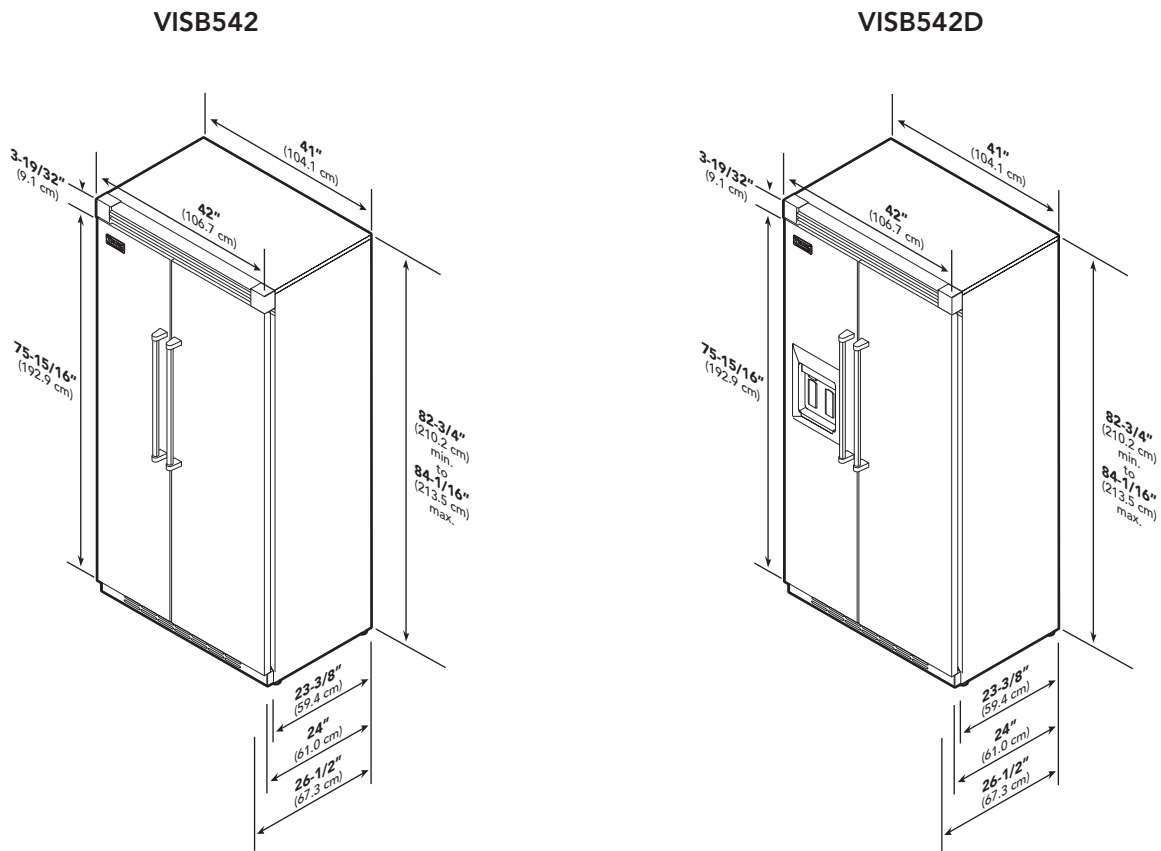

Specifications\*

48" Professional Side-By-Side		
Description	VCSB548	VCSB548D
Overall width	48" (121.9 cm)	
Overall height from bottom	82-3/4" (210.2 cm) min. to 84-1/16" (213.5 cm) max.	
Overall depth from rear		
To front edge of side trim:	22-3/16" (56.4 cm)	
To front of top grille:	24-11/16" (62.7 cm)	
To front of handle end-cap	27-1/4" (69.2 cm)	
Electrical requirements	115 volt, 60 Hz, 15 amp dedicated circuit; 3-wire cord with grounded 3-prong plug attached to product	
Maximum amp usage	9.9 amps	
Inlet water requirements	1/4" copper tubing inlet waterline; minimum 20 psi; maximum 120 psi	1/4" copper tubing inlet waterline; minimum 35 psi; maximum 120 psi
Refrigerant Type	HFC-134a	
Refrigerant Charge	See rating label	
Approximate shipping weight	715 lbs. (321.8 kg)	735 lbs. (330.8 kg)

\*Go to [vikingrange.com](http://vikingrange.com) for latest specifications.

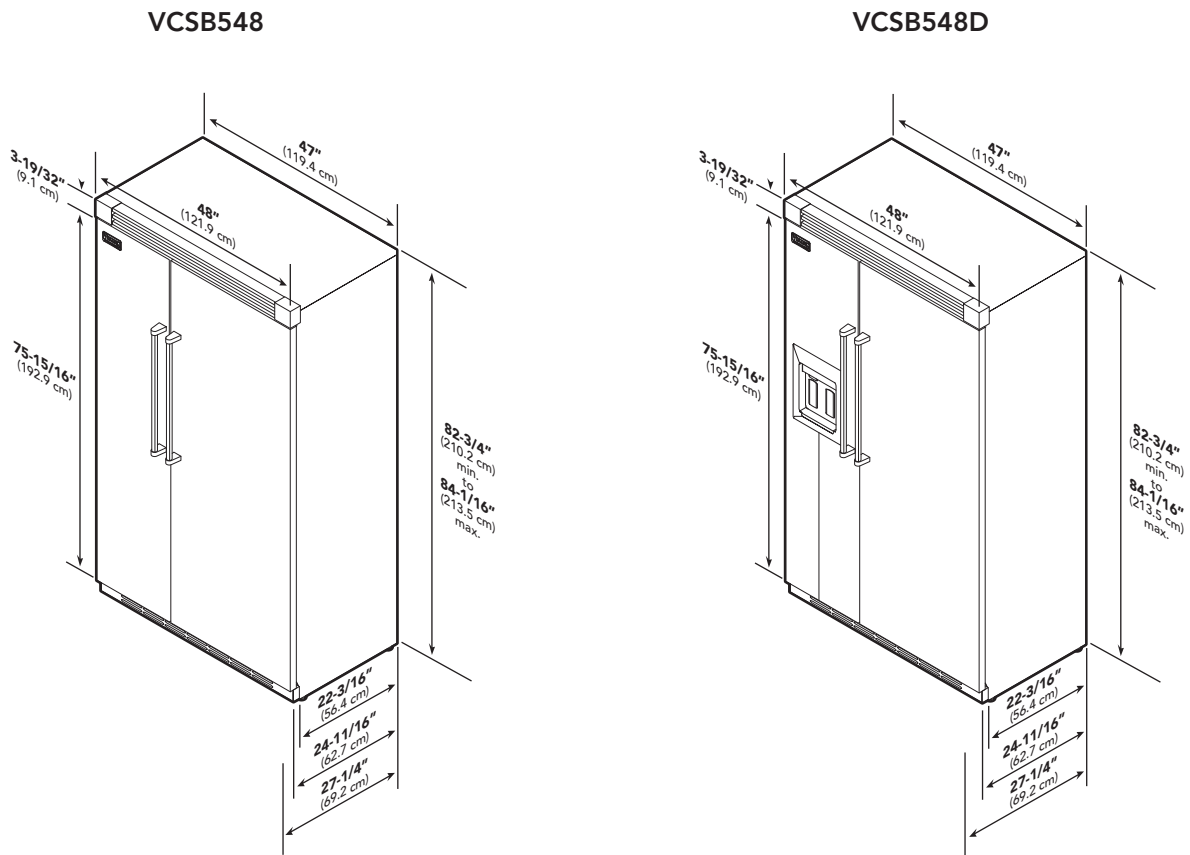

## Specifications\*

48" Professional Side-By-Side		
Description	VISB548	VISB548D
Overall width	48" (121.9 cm)	
Overall height from bottom	82-3/4" (210.2 cm) min. to 84-1/16" (213.5 cm) max.	
Overall depth from rear		
To front edge of side trim:	23-3/8" (59.4 cm)	
To front of top grille:	24" (61.0 cm)	
To front of handle end-cap	26-1/2" (67.3 cm)	
Electrical requirements	115 volt, 60 Hz, 15 amp dedicated circuit; 3-wire cord with grounded 3-prong plug attached to product	
Maximum amp usage	9.9 amps	
Inlet water requirements	1/4" copper tubing inlet waterline; minimum 20 psi; maximum 120 psi	1/4" copper tubing inlet waterline; minimum 35 psi; maximum 120 psi
Refrigerant Type	HFC-134a	
Refrigerant Charge	See rating label	
Approximate shipping weight	715 lbs. (321.8 kg)	735 lbs. (330.8 kg)

\*Go to [vikingrange.com](http://vikingrange.com) for latest specifications.

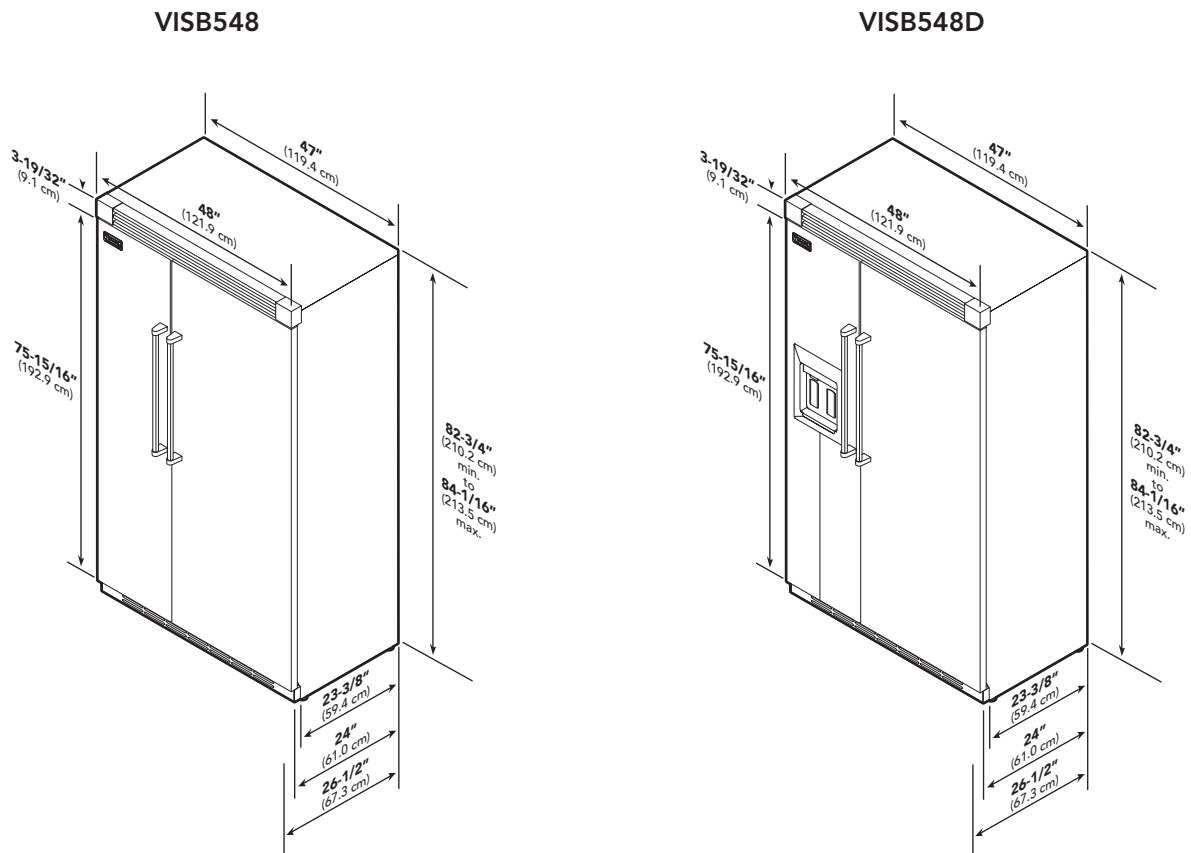

Specifications\*

42" Designer Side-By-Side		
Description	DDSB542	DDSB542D
Overall width	42" (106.7 cm)	
Overall height from bottom	82-3/4" (210.2 cm) min. to 84-1/16" (213.5 cm) max.	
Overall depth from rear		
To front edge of side trim:	23-3/8" (59.4 cm)	
To front of top grille:	24" (61.0 cm)	
To front of handle end-cap	26" (66.0 cm)	
Electrical requirements	115 volt, 60 Hz, 15 amp dedicated circuit; 3-wire cord with grounded 3-prong plug attached to product	
Maximum amp usage	9.9 amps	
Inlet water requirements	1/4" copper tubing inlet waterline; minimum 20 psi; maximum 120 psi	1/4" copper tubing inlet waterline; minimum 35 psi; maximum 120 psi
Refrigerant Type	HFC-134a	
Refrigerant Charge	See rating label	
Approximate shipping weight	642 lbs. (289 kg)	665 lbs. (299.3 kg)

\*Go to [vikingrange.com](http://vikingrange.com) for latest specifications.

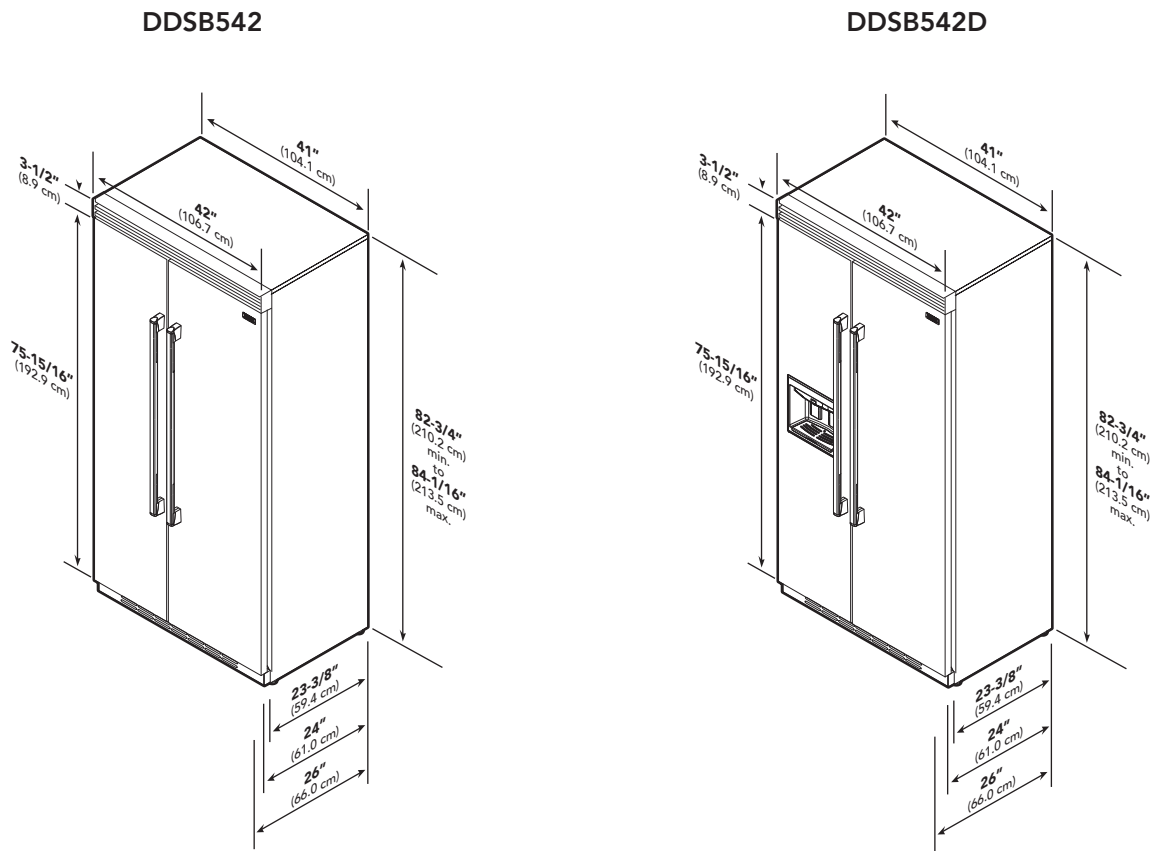

Specifications\*

42" Designer Side-By-Side		
Description	DFSB542	DFSB542D
Overall width	42" (106.7 cm)	
Overall height from bottom	82-3/4" (210.2 cm) min. to 84-1/16" (213.5 cm) max.	
Overall depth from rear	23-3/8" (59.4 cm)	
To front edge of side trim:	24" (61.0 cm)	
To front of top grille:	26" (66.0 cm)	
Electrical requirements	115 volt, 60 Hz, 15 amp dedicated circuit; 3-wire cord with grounded 3-prong plug attached to product	
Maximum amp usage	9.9 amps	
Inlet water requirements	1/4" copper tubing inlet waterline; minimum 20 psi; maximum 120 psi	1/4" copper tubing inlet waterline; minimum 35 psi; maximum 120 psi
Refrigerant Type	HFC-134a	
Refrigerant Charge	See rating label	
Approximate shipping weight	642 lbs. (289 kg)	665 lbs. (299.3 kg)

\*Go to [vikingrange.com](http://vikingrange.com) for latest specifications.

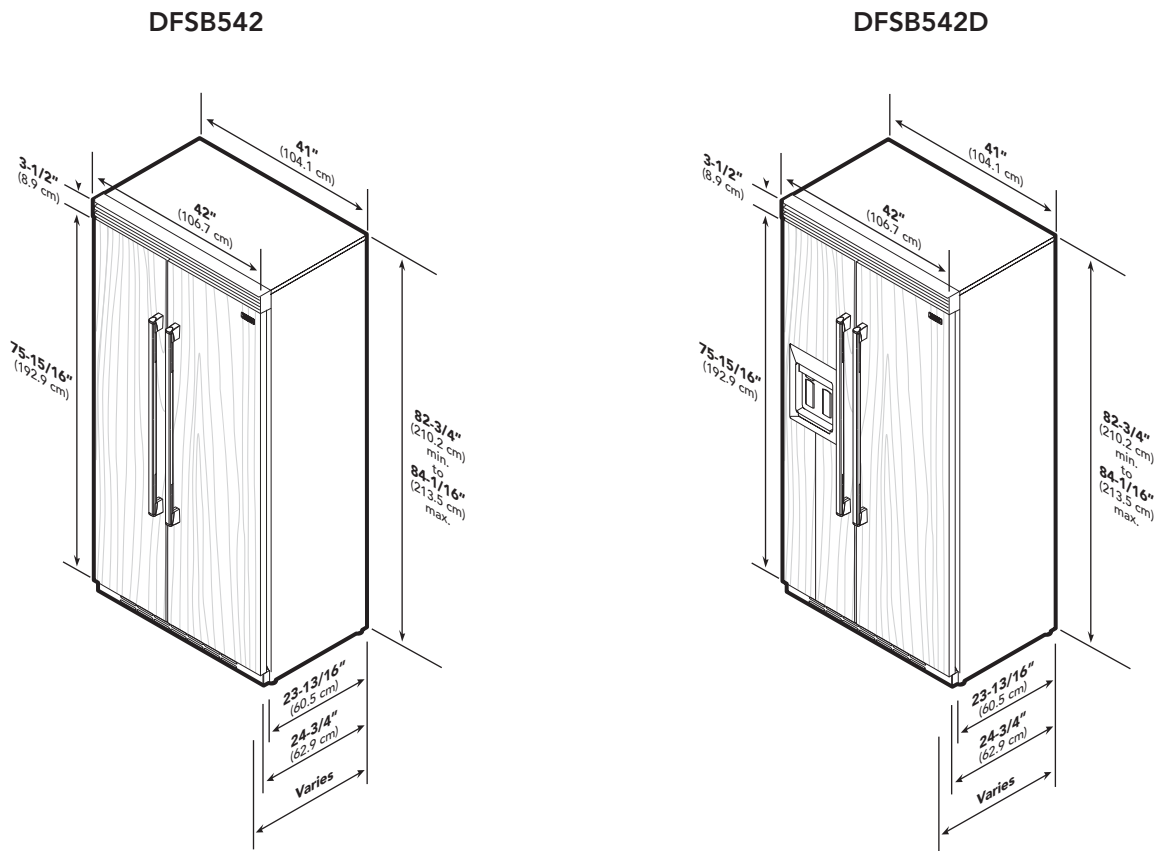



Specifications\*

48" Designer Side-By-Side		
Description	DDSB548	DDSB548D
Overall width	48" (121.9 cm)	
Overall height from bottom	82-3/4" (210.2 cm) min. to 84-1/16" (213.5 cm) max.	
Overall depth from rear	23-3/8" (59.4 cm)	
To front edge of side trim:	24" (61.0 cm)	
To front of top grille:	24" (61.0 cm)	
To front of handle end-cap	26" (66 cm)	
Electrical requirements	115 volt, 60 Hz, 15 amp dedicated circuit; 3-wire cord with grounded 3-prong plug attached to product	
Maximum amp usage	9.9 amps	
Inlet water requirements	1/4" copper tubing inlet waterline; minimum 20 psi; maximum 120 psi	1/4" copper tubing inlet waterline; minimum 35 psi; maximum 120 psi
Refrigerant Type	HFC-134a	
Refrigerant Charge	See rating label	
Approximate shipping weight	642 lbs. (289 kg)	665 lbs. (299.3 kg)

\*Go to [vikingrange.com](http://vikingrange.com) for latest specifications.

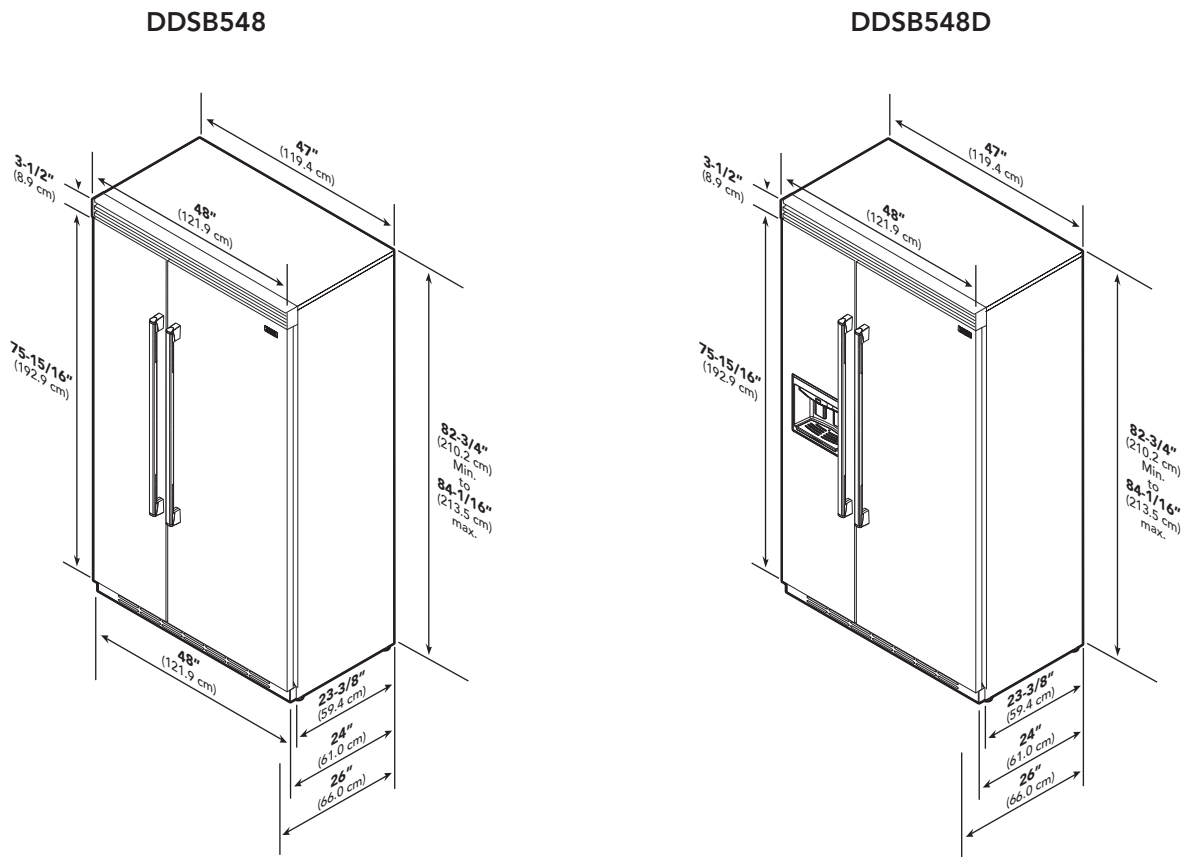

## Specifications\*

48" Designer Side-By-Side		
Description	DFSB548	DFSB548D
Overall width	48" (121.9 cm)	
Overall height from bottom	82-3/4" (210.2 cm) min. to 84-1/16" (213.5 cm) max.	
Overall depth from rear To front edge of side trim: To front of top grille: To front of handle end-cap	23-3/8" (59.4 cm) 24" (61.0 cm) varies	
Electrical requirements	115 volt, 60 Hz, 15 amp dedicated circuit; 3-wire cord with grounded 3-prong plug attached to product	
Maximum amp usage	9.9 amps	
Inlet water requirements	1/4" copper tubing inlet waterline; minimum 20 psi; maximum 120 psi	1/4" copper tubing inlet waterline; minimum 35 psi; maximum 120 psi
Refrigerant Type	HFC-134a	
Refrigerant Charge	See rating label	
Approximate shipping weight	642 lbs. (289 kg )	675 lbs. (303.8 kg)

\*Go to [vikingrange.com](http://vikingrange.com) for latest specifications.

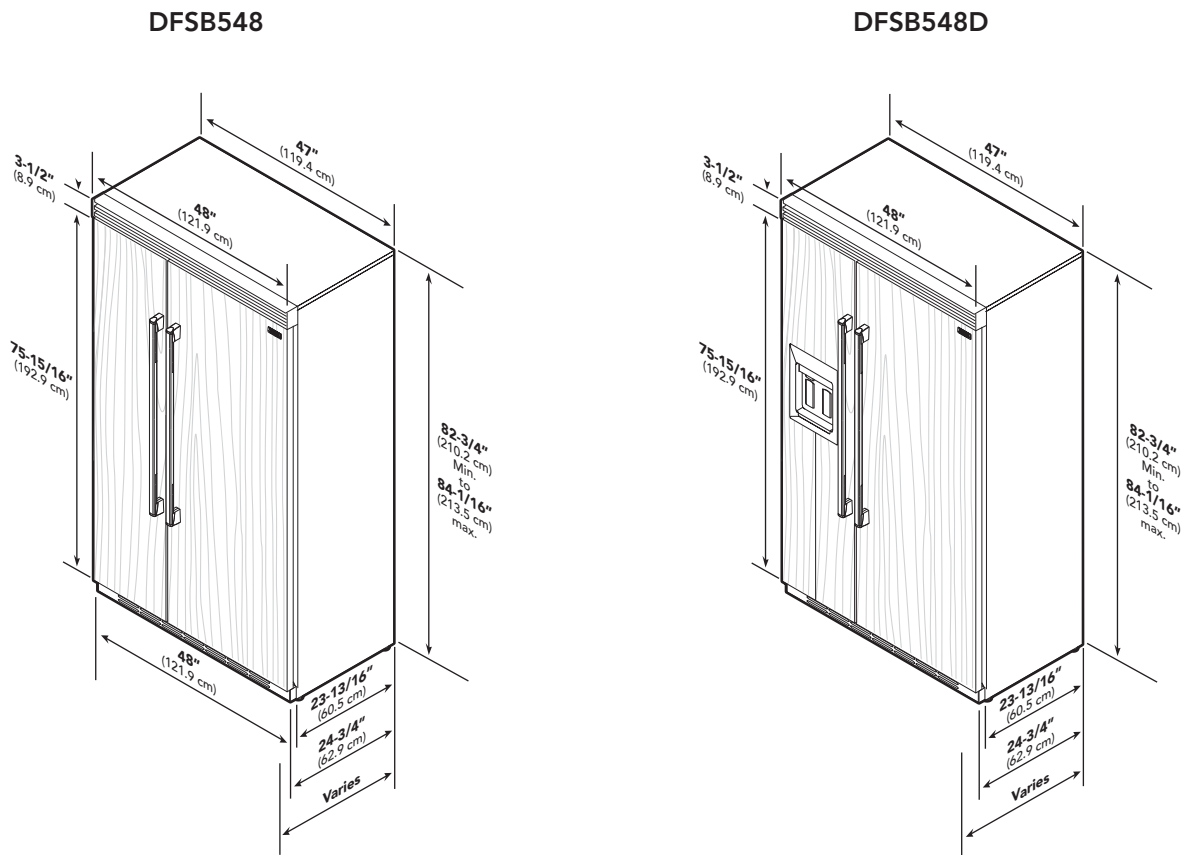

## Warnings

Read and follow all instructions before using this appliance to prevent the potential risk of fire, electric shock, personal injury, or damage to the appliance as a result of improper usage of the appliance. Use appliance only for its intended purpose as described in this manual.

To ensure proper and safe operation: appliance must be properly installed and grounded by a qualified technician. **DO NOT** attempt to adjust, repair, service, or replace any part of your appliance unless it is specifically recommended in this manual. All other servicing should be referred to a qualified servicer.

Make sure that incoming voltage is the same as unit rating. An electric rating plate specifying voltage, frequency, wattage, amperage, and phase is attached to the product.

### Electrical Requirements

Assure that the electrical installation is adequate and in conformance with the National Electrical Code, ANSI/NFPA 70-latest edition or Canadian Electrical Code C22.1-1998 and C22.2 No. 0-M91 (or latest edition), and all local codes and ordinances. A 115 volt, 60 Hz, 15 amp, fused, electrical supply is required. It is required that a separate circuit serving only this appliance be provided. This appliance is equipped with a power supply cord having a 3-prong grounding plug. To minimize possible shock hazard, the cord must be plugged into a mating 3-prong, grounding-type wall receptacle. **DO NOT use an extension cord.**

### Tip Over Hazard

Most of the unit's weight is at the top. Extra care is needed when moving the unit to prevent tipping. Keep doors closed until appliance is completely installed and secured per installation instructions. Use two or more people to move and install appliance. Failure to do so can result in death or serious injury.



### WARNING

#### TIP OVER HAZARD

Appliance is top heavy and tips easily when not completely installed. Keep doors closed until appliance is completely installed and secured per installation instructions.

Use two or more people to move and install appliance. Failure to do so can result in death or serious injury.



### WARNING

#### ELECTRICAL SHOCK HAZARD

Disconnect power or turn power disconnect switch to "OFF" position before removing top grille. Failure to do so can result in death or electrical shock.



### WARNING

#### ELECTRICAL SHOCK HAZARD

Plug into a grounded 3-prong outlet. If a 2-prong wall receptacle is encountered, contact a qualified electrician.

**DO NOT** remove ground prong.

Unit must be grounded at all times.

**DO NOT** use an adapter.

**DO NOT** use an extension cord.

Failure to follow these instructions can result in death, fire, or electrical shock.



### WARNING

#### BURN HAZARD

**DO NOT** touch condenser coils near defrost pan. Doing so can result in burns.

## Model – Serial Number Matrix

The serial number and model number for your appliance are located on the identification plate mounted on the upper left side of the door opening.

### Model Numbers

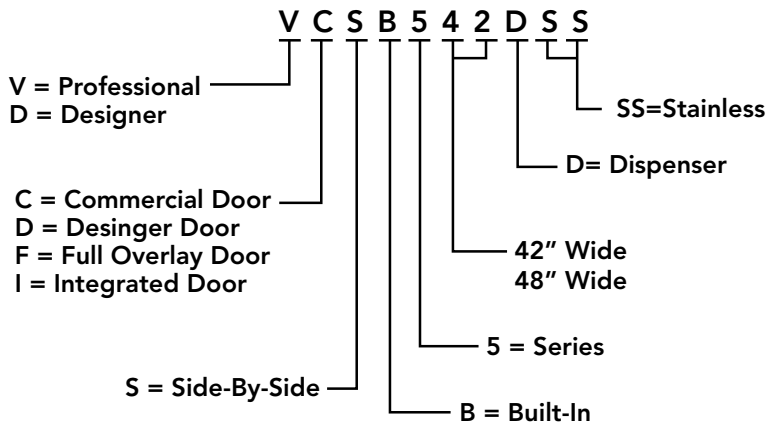

### Serial Numbers

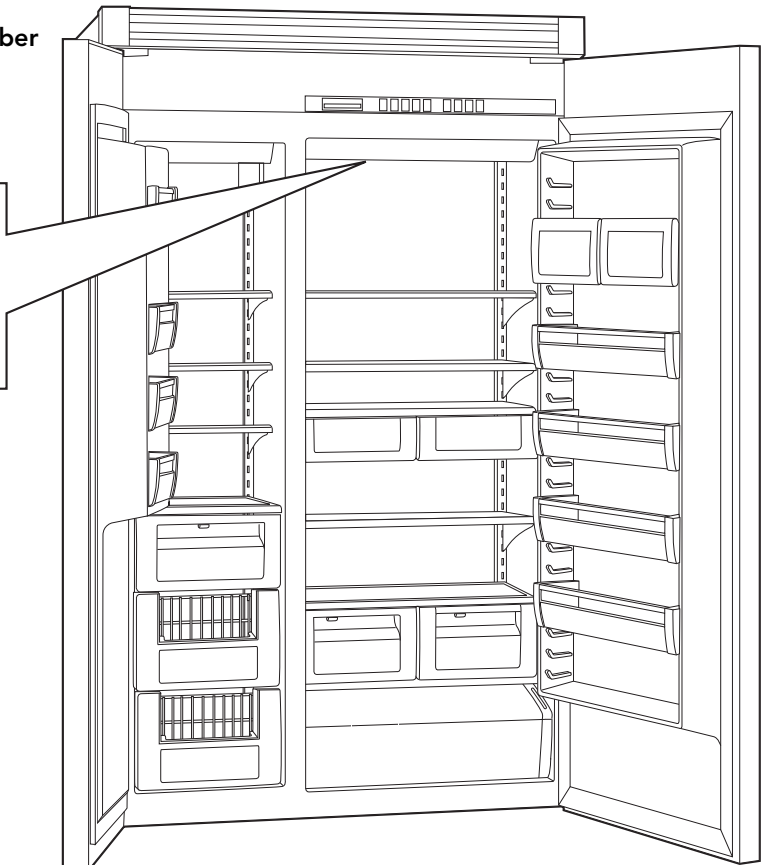
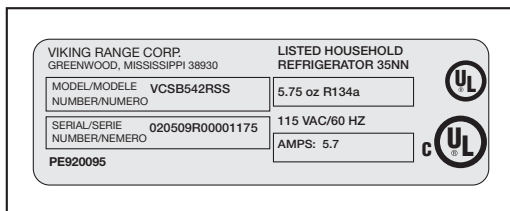
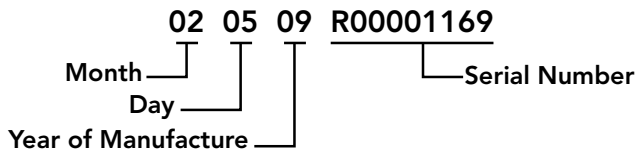

## Settings and Functions

In order for your new refrigerator to work properly, it is important that you understand its various features, controls, and how to use them.

### Power On/Off Switch (Power Interruption Switch)

The power on/off switch is located behind your refrigerator's top grille. It is used to turn the power "OFF" when cleaning the refrigerator or changing the light bulbs. Your refrigerator arrives from the factory with the power interruption switch "ON".

To turn power "OFF", remove the center grille blade. Press the power on/off switch to the "OFF" position.

To turn power "ON", press power on/off switch to the "ON" position. Replace the center grille blade.

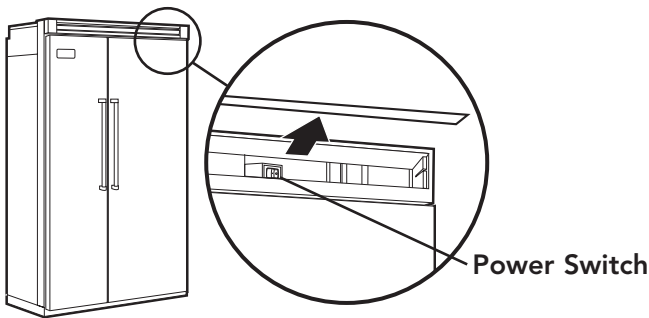

**IMPORTANT:** Be sure the power on/off switch is in the "ON" position after cleaning or changing light bulbs.

### Showroom Mode Initiation

Showroom mode allows electronic controls and interior lights to function independently of the refrigeration system.

To enter Showroom mode: Press and hold the "ACTIVATE CONTROLS" pad. While holding, press and hold the "HIGHER" and "ALARM OFF" pad simultaneously. One beep will be heard indicating that sequence was entered properly. Continue holding until three beeps are heard and then the Blue LED two steps to the right of the "HIGH TEMP" indicator will illuminate. Showroom mode is entered.

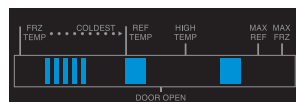
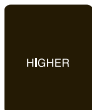

To exit Showroom mode: Press and hold the "ACTIVATE CONTROLS" pad. While holding, press and hold the "HIGHER" and "ALARM OFF" pad simultaneously. One beep will be heard indicating that sequence was entered properly. Continue holding until three beeps are heard. The display will revert to normal operation

### Electronic Temperature Settings

Your refrigerator's electronic controls are located behind the door above the cabinet interior. To activate the electronic control panel, press "ACTIVATE CONTROLS" pad. All other pads, except the "Alarm Off" pad, will remain inactive until the "ACTIVATE CONTROLS" pad is pressed. Once activated, pad remains programmable for at least ten minutes.



When you first plug your new refrigerator in, you will find that five bars of nine are displayed. This means that all unit controls are pre-set at the mid-range setting. Wait 24 hours after plug-in for the cabinets to reach this setting. After 24 hours, you may adjust controls as desired. The warmest setting displays one bar, while the coldest setting shows nine bars.

To adjust the refrigerator or freezer temperature, simply press the "ACTIVATE CONTROLS" pad, then "REF TEMP" pad or "FRZ TEMP" pad. Press the "HIGHER" or "LOWER" pad to adjust temperature setting one level at a time. Holding down the "HIGHER" or "LOWER" pad adjusts temperature more than one level at a time.



### Key Press Confirmation

The key press confirmation is the "beep" heard when a control pad is pressed. The confirmation can be activate or inactive.

To activate the key press confirmation, press and hold the "ACTIVATE CONTROLS" pad for three to five seconds. Three beeps will be heard confirming the key press confirmation has been deactivated.



To activate the key press confirmation, press and hold the "ACTIVATE CONTROLS" pad until confirmation beep is heard.

## Settings and Functions (continued)

### Max Refrigerator Mode



Max refrigerator mode adjusts the refrigerator temperature to the coldest setting for four hours, at the end of which the refrigerator's temperature automatically returns to its previous setting.



To activate the max refrigerator mode, simply press the "ACTIVATE CONTROLS" pad, followed by the "MAX REF" pad. The indicator light will glow to let you know you've turned on the max refrigerator mode.

To deactivate the max refrigerator mode before the end of the four hour cycle, press the "ACTIVATE CONTROLS" pad, followed by the "MAX REF" pad.



### Max Freezer Mode

Max freezer mode adjusts the freezer temperature to the coldest setting for 4 hours, at the end of which, the freezer temperature automatically returns to its previous setting.

To activate the max freezer mode, press the "ACTIVATE CONTROLS" pad, followed by the "MAX FRZ" pad. The indicator light will glow to let you know you have turned on the max freezer mode.

To deactivate the max freezer mode before the end of the 4 hour cycle, simply press the "ACTIVATE CONTROLS" pad, followed by the "MAX FRZ" pad.

### Door Open Alarm

The door open alarm sounds and an indicator light blinks if either door is left open for more than three minutes.



To deactivate the door open alarm, press the "ALARM OFF" pad or close the door that is open.

### High Temperature Alarm

The high temperature alarm sounds and an indicator light glows if the refrigerator or the freezer temperature is too high for two hours. A blinking light signals which part of the appliance is affected. The alarm will end when the temperature is brought back to a proper setting.

To deactivate the high temperature alarm, press the "ALARM OFF" pad.



### Thermistor Alarm

The thermistor alarm is a special feature that electronically senses temperature problems. The thermistor alarm will sound and indicator lights 4-7 will scroll if the thermistor is not operating properly. The alarm can be deactivated by pressing the "ALARM OFF" pad on your refrigerator's control panel. **If the alarm continues to sound, contact an authorized Viking Range Corporation technician immediately.**

### Display Panel

To activate Control panel and display, press the "ACTIVATE CONTROLS" pad.



To deactivate Control panel and display, press the "ACTIVATE CONTROLS" or "DISPLAY OFF" pad.



### Sabbath Mode

Sabbath mode is used to disable interior lights and alarms for observance of the Sabbath.

Before the Sabbath mode is engaged, the bale arm of the ice maker needs to be raised until it clicks into the detent. This turns off the power to the ice maker.

To enter Sabbath mode, press the "ACTIVATE CONTROLS" pad to activate the control panel. Then, press and hold "ACTIVATE CONTROLS" and "DISPLAY OFF" pads simultaneously for three seconds. It will beep three times and light the three right blue squares so you will know that you have activated Sabbath mode.

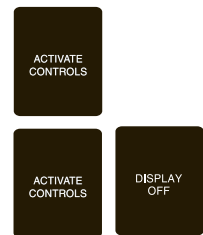

When your refrigerator is in Sabbath mode, interior lights, display (excluding the three right hand side lit blue squares), and alarms are disabled.

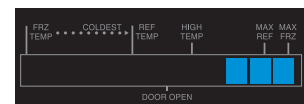

## Settings and Functions (continued)

If your refrigerator loses power while in Sabbath mode, it will return to the Sabbath mode when power is reestablished.



To exit the Sabbath mode, press the "ACTIVATE CONTROLS" pad. Then, press and hold "ACTIVATE CONTROLS" and "DISPLAY OFF" pads simultaneously for three seconds. You will then hear three beeps letting you know that you have turned the Sabbath mode "OFF".

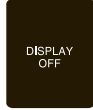

Once your refrigerator has left the Sabbath mode, the bale arm of the ice maker needs to be pushed downward until it is no longer in the detent. This will restore power to the ice maker.

### Setting the Controls

Adjust control setting by using a high quality household temperature thermostat that can read temperatures between -5° to -50°F (-21° to 10°C).

### Checking the Temperature (freezer)

Place the thermometer snugly between frozen packages in freezer section. Wait five to eight hours, then check the temperature. If the freezer temperature is not 0° to 2°F (-17° to -16°C), adjust the temperature control one number at a time. Then, check the temperature again in five to 8 hours.

### Checking the Temperature (refrigerator)

Place the thermometer in a glass of water in the middle of the refrigerator. Wait five to eight hours, and then check the temperature. If the refrigerator temperature is not 38° to 40°F (3° to 4°C), adjust the control one number at a time. Check again after five to eight hours.

## Automatic Ice Maker

After the refrigerator reaches normal temperature, the ice maker fills with water and begins operating. Under normal conditions, the ice maker will produce seven to nine batches of ice per 24 hour period.

**Note:** Allow 24 to 48 hours after installation before looking for ice in your ice drawer. You should discard the first three full drawers of ice produced by your refrigerator, and should also throw out the first drawer full of ice your refrigerator produces after extended periods of non-use.

## Door Stop Adjustment

Your refrigerator is factory set at 110° door stop position. To change to either the 90° or 120° position, remove the door stop pin located in the bottom hinge using a 3/16" allen wrench. For 120° swing, move the pin to stop hole closest to the unit. For 90° swing, move pin to stop hole farthest from the unit.

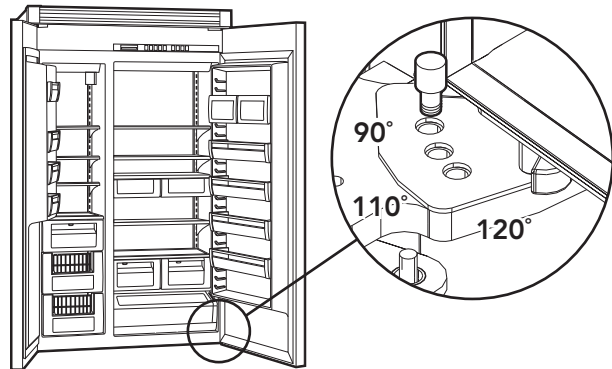

## Light Bulb

Disconnect power at breaker or turn power disconnect switch to the off position. Lightly grasp light cover with both hands and pull down. Replace bulb with an incandescent, medium base tubular bulb with a maximum of 40 watts. Replace cover by engaging light bracket with the back fingers on the light cover. Once engaged, snap the front fingers on the light cover.

**Note:** The clear section of the light cover is considered the back section. Reconnect power or turn power disconnect switch to the "ON" position.



## Door Hinge Adjustment

Removal of the upper grill assembly allows access to door hinge for adjustment.

### To remove upper grill:

1a. (Professional) Lift center grille louver up and pull out.

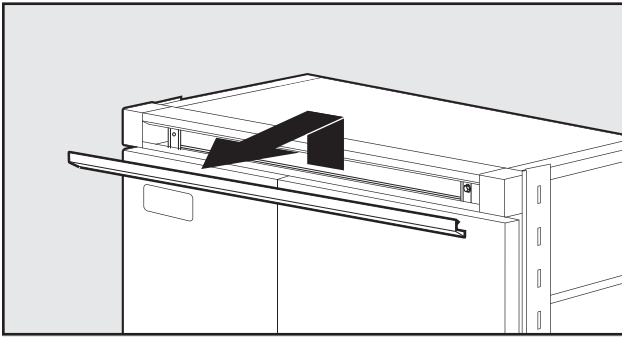

1b. (Designer) Pull the center grille louver up at an angle and pull out.

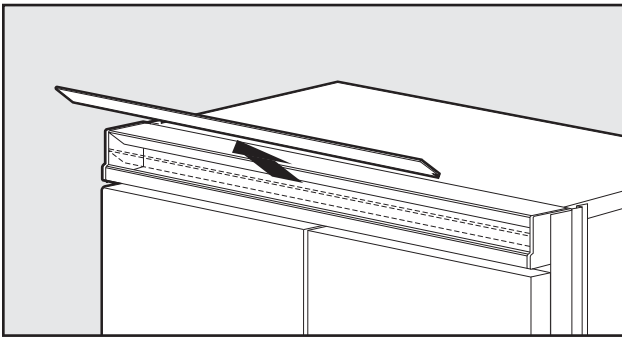

2. Using an 8" magnetic nut driver, remove the two 1/4" screws.

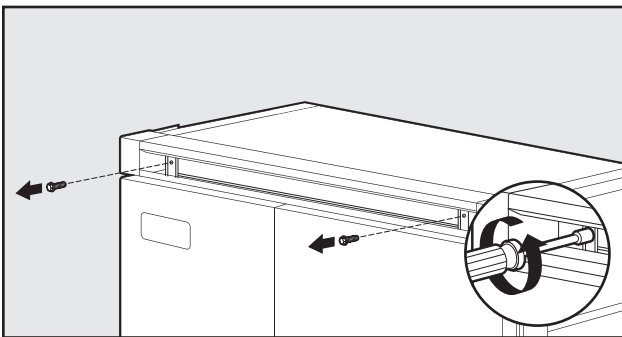

3. Remove grille assembly.

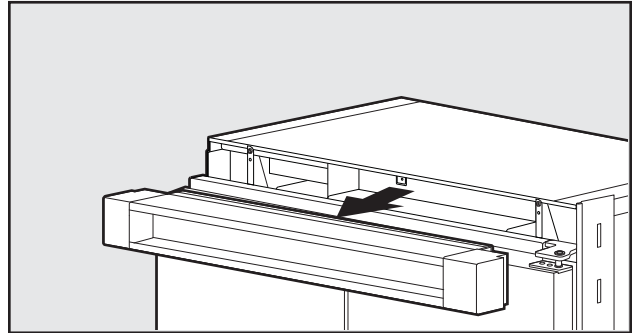

4. Remove four side screws and remove unit top.

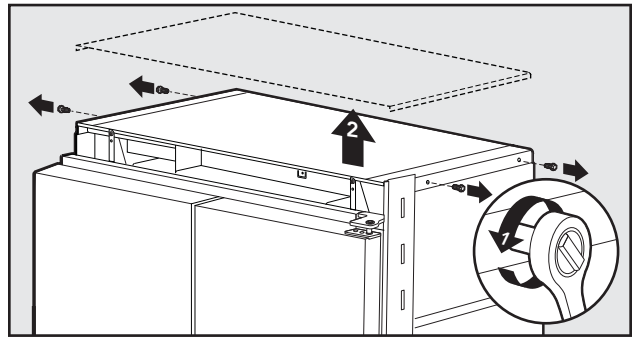

5. Loosen the four hinge screws. Adjust door.

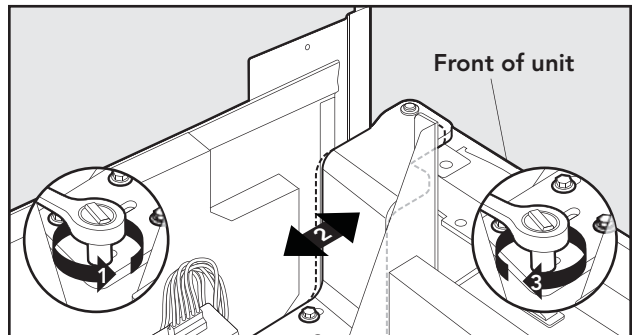

6. Reverse procedure for reinstallation.

## Height Adjustment

Removal of the kickplate allows access to rollers and stabilizing legs for height adjustment.

1. Remove lower kickplate screws using a Phillips screwdriver.

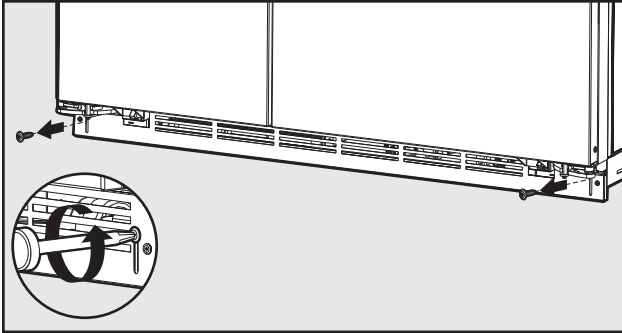

2. Remove upper kickplate screws using a Phillips screwdriver. Remove kickplate assembly.

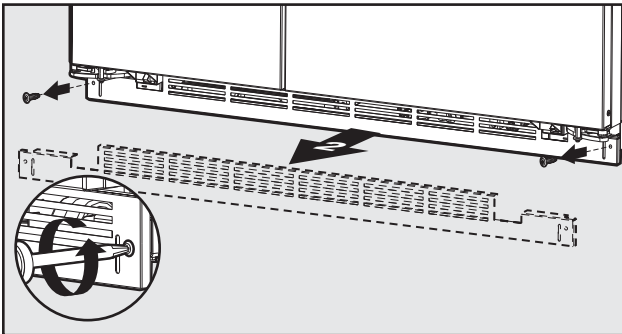

3. Using a 5/16" head wrench, turn the front (F) adjustment screws to raise or lower the front of the refrigerator.

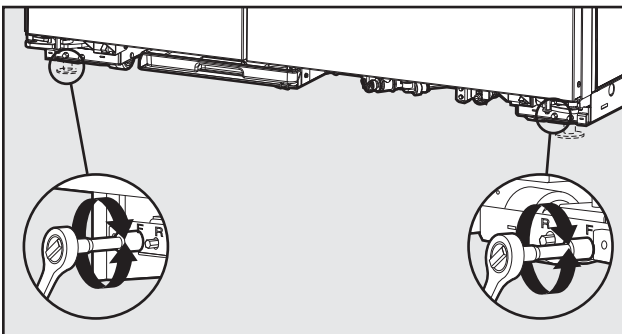

**Note: DO NOT use an electric device. Overtightening can cause damage.**

4. Using a 5/16" head wrench, turn the rear (R) adjustment screws to raise or lower the rear of the refrigerator.

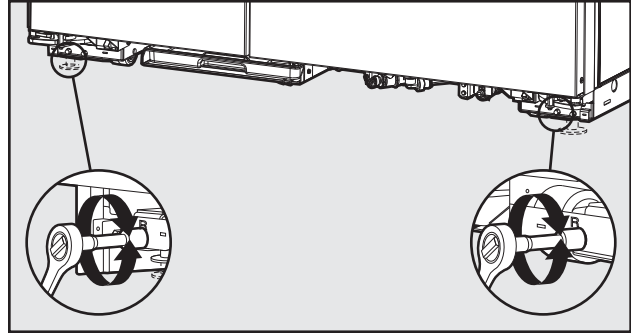

**Note: DO NOT use an electric device. Overtightening can cause damage.**

5. Reinstall kickplate.

## Display Panel Operation

The unit being serviced has a control panel that allows operation of the unit as well as diagnostic abilities. See the information below for details.

Operation	Description	How to Access Function
Keyboard Entry Tone	Indicates a pad was pressed, command was read, and accepted	To turn off entry tone, press and hold "ACTIVATE CONTROLS" pad for 3 to 5 seconds
Command Accepted Tone	Three short tones sound indicating a command has been accepted	
Activate Controls Pad	If the pad is activated, the display panel remains active at least 10 minutes after the door is closed	Press the "ACTIVATE CONTROLS" pad
Freezer Temperature Pad	Freezer indicator light will glow and freezer temperature will be displayed. Factory setting is 5	Press "HIGHER TEMP" or "LOWER TEMP" pad
Ref Temp Pad	Refrigerator indicator light will glow and refrigerator temperature will be displayed. Factory setting is 5	Press "HIGHER TEMP" or "LOWER TEMP" pad
Higher Temp Pad	Raises temperature settings one bar at a time	Press "HIGHER TEMP" pad. To raise temperature at a faster rate, hold the pad down
Lower Temp Pad	Lowers temperature settings one bar at a time	Press "LOWER TEMP" pad. To lower temperature at a faster rate hold, the pad down
Max Freezer Pad	Sets freezer temperature to coldest setting. Factory setting is 4 hours	Press "MAX FRZ" Pad to engage. A second press will disengage feature
Max Ref Pad	Sets refrigerator temperature to coldest setting. Factory setting is 4 hours	Press "MAX REF" pad to engage. A second press will disengage feature
Alarm Off Pad	Turns alarm signal off	Press "ALARM OFF" to terminate audible alarm, visual indicator light will continue to blink until alarm condition is cleared or permanently disabled. To reactivate, press and hold "ALARM OFF" pad for 3 seconds
Hidden Button	Puts unit in program mode	Open refrigerator door. Press "ACTIVATE CONTROLS" pad. Press hidden button (refer to control panel for unit being serviced). Within 6 seconds of pressing the hidden button, press "MAX REF", "MAX FRZ", "MAX REF", "MAX FRZ". Tone will sound 3 times and control will be in program mode A. Refer to Program Mode section
Display Off Pad	Deactivates control panel	Press "DISPLAY OFF" pad to deactivate display. Press "ACTIVATE CONTROLS" pad to reactivate

## Program Modes

### Side-By-Side Control Panel

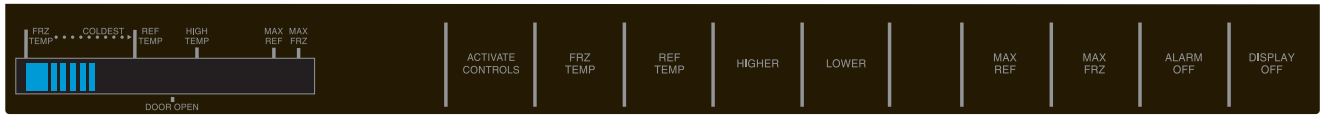

Two programming modes are available for the side-by-side unit. Mode A allows the reading of both the Freezer and Fresh Food Thermistor. It is also used to program the following:

- Defrost Duration (when set to Conventional Defrost in Mode B)
- VCC speed (speed in which compressor will operate)
- Freezer and Fresh Food Cut-In/Cut-Out Differential (temperature difference between cycle "OFF" and cycle "ON" temperatures). Mode B is used for all other programmable functions. To access the program modes follow the steps below.

1. Open the refrigerator door.
2. Press "ACTIVATE CONTROLS" pad (to right of display window). Then press "HIDDEN BUTTON" pad (located between "Lower" and "Max Ref" pad).

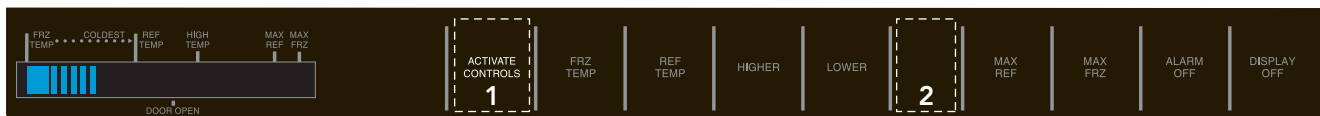

3. Within 6 seconds press the "MAX REF" pad, then press the "MAX FRZ" pad, the "MAX REF" pad, then press the "MAX FRZ".

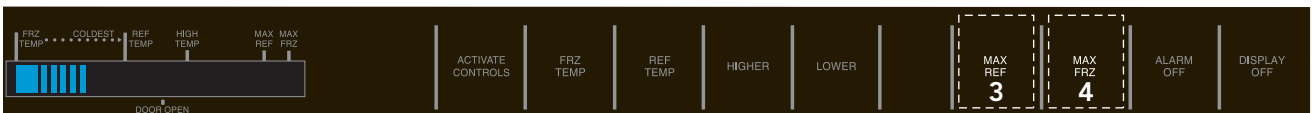
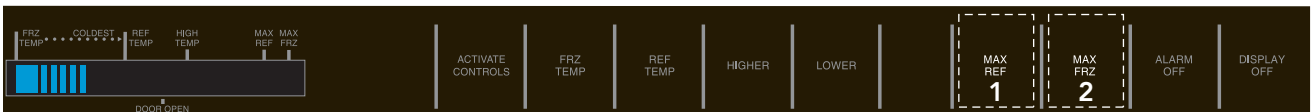

4. An audible tone will sound three times confirming the unit is in Program Mode A and the orange LED to the right of the HIGH TEMP indicator will illuminate.

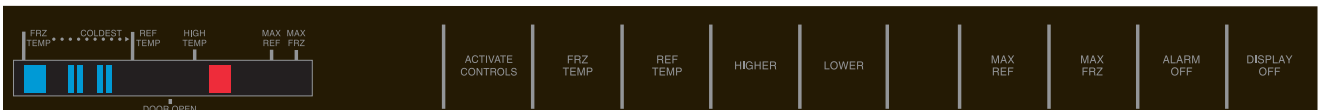

## Mode A Functions

### Reading Temperature Display

The temperature display will show thermistor temperature in binary code. The display has nine indicator lights that will light up to display the temperature. Lights 1 – 4 indicate the first digit of the compartment temperature and lights 5 – 8 indicate the second digit of the compartment temperature. The ninth light will light up for a negative temperature.



To read the temperature of the unit from the display, refer to the code chart below.

Indicator	1	2	3	4	5	6	7	8	9 Not Illuminated	9 Illuminated
Value	8	4	2	1	8	4	2	1	+ Temperature	- Temperature

Below is an example of the Fresh Food Thermistor. In the first group of 4 indicators (10's column) indicator 3 and 4 are lit. In the second group of 4 indicators (0's column) indicator 6 and 7 are lit. Add all the values to calculate the compartment temperature.



Indicator 3 is illuminated this is a value of 2 or 20 degrees  
 Indicator 4 is illuminated this is a value of 1 or 10 degrees  
 Add Indicator 3 and 4 together to get a total temp of 30 degrees for the 10's column.

Indicator 6 is illuminated this is a value of 4 or 4 degrees  
 Indicator 7 is illuminated this is a value of 2 or 2 degrees  
 Add Indicator 6 and 7 together to get a total temp of 6 degrees for the 1's column.

Indicator 9 is not illuminated so the temperature is positive.

The compartment temperature for this example would be 36 degrees.

## Mode A Functions (continued)

### Freezer Thermistor Temperature

When Service Mode A is entered, press the "FRZ TEMP" pad. Using the code on page 23, add up the value of the illuminated bars to get the current Freezer temp. The example below shows a Freezer Temp of 20°F.

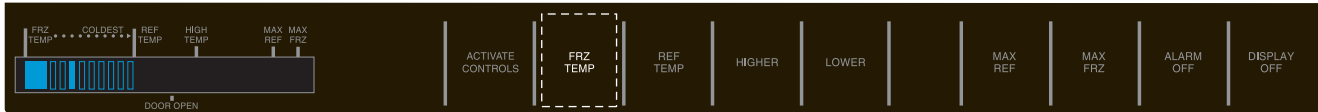

### Refrigerator Thermistor Temperature

When Service Mode A is entered, press the "REF TEMP" pad. Using the code on page 23, add up the value of the illuminated bars to get the current Fresh Food temp. The example below shows a Fresh Food temp of 36°F.

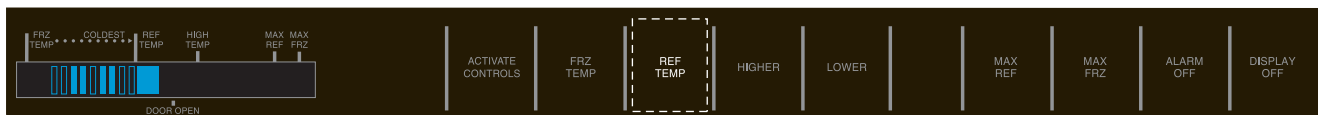

### Optional Conventional Defrost

The unit comes set from the factory for Adaptive Defrost. In the event that more or less defrost intervals are required, the unit can be set for a conventional defrost cycle. In this mode the defrost program can be set to predetermined defrost times. **Note:** The defrost intervals are set in SERVICE MODE A. In order to activate the conventional defrost system, it must be initiated in SERVICE MODE B. See *Defrost Mode Selection—Service Mode B* on Page 27.

To change the defrost time, place the unit in Program Mode A (see *Program modes* on page 22). When you have entered SERVICE MODE A, Press and hold the "DISPLAY OFF" pad for 3 seconds. 1 audio confirmation beep will be heard. Both the FRZ temp and REF temp LED will extinguish. The orange LED to the right of the High Temp LED and (1) bar will be lit. The default conventional defrost setting is the 4th bar (8 hours) shown below.

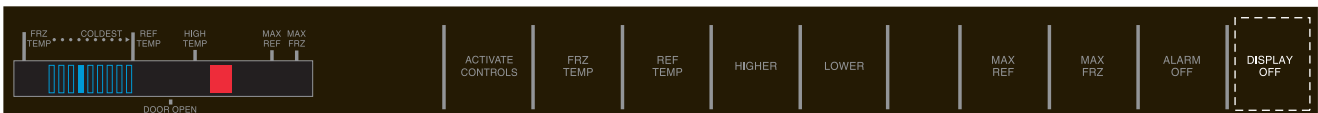

The Conventional Defrost time will be displayed by use of one of the temperature indicators. The times can be set to 4, 5, 6, 8, 12, 16, 18, 20, and 24 hours of Compressor Run Time (CRT).

The intervals are changed by using the HIGHER and LOWER Temp key pads. Each press of the "HIGHER" pad will decrease the defrost time by one level while each press of the "LOWER" pad once will increase the defrost time by one level in the other direction. Once Conventional defrost is initiated in SERVICE MODE B, the first defrost will always be 4 hours of CRT regardless of the level it has been changed to.

The indicator light and corresponding Defrost Times are listed below.

Indicator	1	2	3	4*	5	6	7	8	9
Defrost Time	4 hours	5 hours	6 hours	8 hours	12 hours	16 hours	18 hours	20 hours	24 hours

\*Default setting

To exit Adjustable Conventional Defrost, press the "ACTIVATE CONTROLS" key.

## Mode A Functions (continued)

### VCC Compressor Frequency

This allows adjustment of the compressor frequency used when the compressor is running at low speed. (A new LV board comes at default setting of 7.) Place the unit in Program Mode A (see *Program Mode on page 22*). Press the "HIDDEN BUTTON" pad. An audio confirmation beep will be heard. The blue LED to the right of the orange LED will be lit. The Compressor Frequency will be displayed by having one of the nine segment indicators being lit.



The compressor speed frequency value is changed by using the Higher Temp and Lower Temp keys. Pressing the "HIGHER TEMP" key once will lower the frequency by one level; pressing the "LOWER TEMP" key once will increase the frequency.

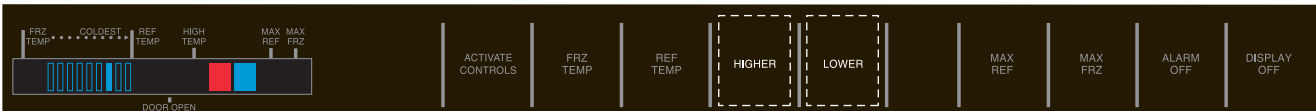

The indicator light and corresponding Compressor Frequencies are listed below.

Indicator	1	2	3	4	5	6	7	8	9
VCC Compressor Frequency	55 Hz	57 Hz	62 Hz	65 Hz	67 Hz	70 Hz	<b>75 Hz*</b>	80 Hz	85 Hz

\*Default setting

### Temperature Differentials for Freezer and Fresh Food Compartments

**Note:** These settings should not be changed unless instructed by Technical support or if the settings are not at the defaults. Improper operation of the unit can result if settings are altered!

#### Refrigerator Cut-In/Out Temperature Differential

The parameter defines the temperature separation between the refrigerator cut-in and cut-out temperatures. Place the unit in Program Mode A (see *Program Mode on page 22*). Press the "MAX REF" pad. An audio confirmation beep will be heard. The Max Ref indicator will be illuminated. The differential temperature will be displayed by use of one of the nine temperature indicator bars. The 9th bar is the default setting for the fresh food compartment.

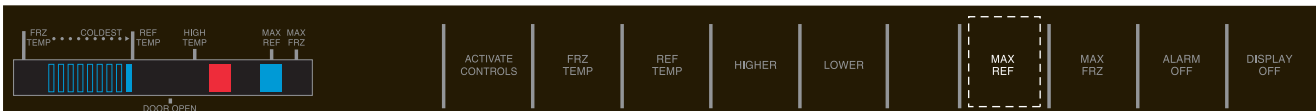

The differential temperature is changed by using the Higher Temp and Lower Temp keys. Pressing the "HIGHER TEMP" key once will change the differential temperature by one level; pressing the "LOWER TEMP" key once will change the differential temperature by one level in the opposite direction.

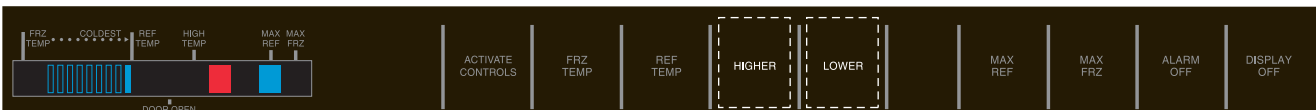



## Mode A Functions (continued)

The indicator light and corresponding differential temperatures are listed below.

Indicator	1	2	3	4	5	6	7	8	9
Cut-In/Out Temperature Differential	3	5	5	6	7	8	9	10	12*

\*Default setting

### Freezer Cut-In/Out Temperature Differential

**Note:** Settings should not be changed unless instructed or if they are not correct.

The parameter defines the temperature separation between the freezer cut-in and cut-out temperatures. Place the unit in Program Mode A (see Program Mode on page 22). Press the "MAX FRZ" pad. An audio confirmation beep will be heard. The Max Frz indicator will be illuminated. The differential temperature will be displayed by use of one of the nine temperature indicator bars. The 9th bar is the default setting for the freezer compartment.

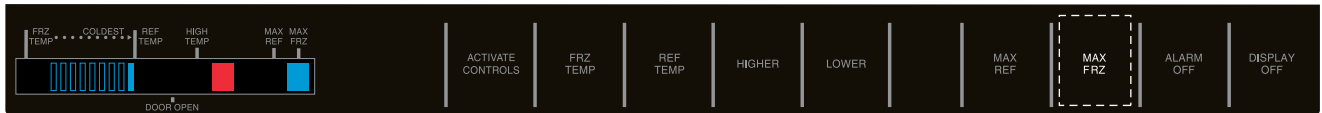

The differential temperature is changed by using the Raise Temp and Lower Temp keys. Pressing the "RAISE TEMP" key once will change the temperature by one level; pressing the "LOWER TEMP" key once will change the temperature by one level in the opposite direction.

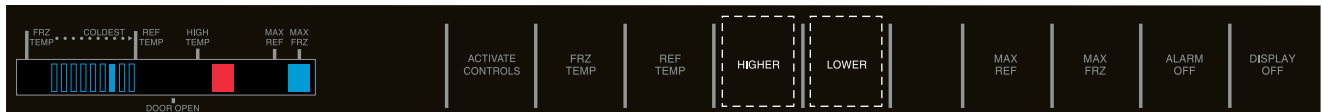

The indicator light and corresponding differential temperatures are listed below.

Indicator	1	2	3	4	5	6	7	8	9
Cut-In/Out Temperature Differential	3	4	5	6	7	9	11*	13	15

\*Example shown above

## Mode B Functions

Once in Program Mode A (see *Program Mode* on page 22), press “ACTIVATE CONTROLS” pad to enter Program Mode B. The orange LED to the right of the HIGH TEMP indicator will turn off and the High Temp light will turn on. This indicates the controller is in Service Mode B.

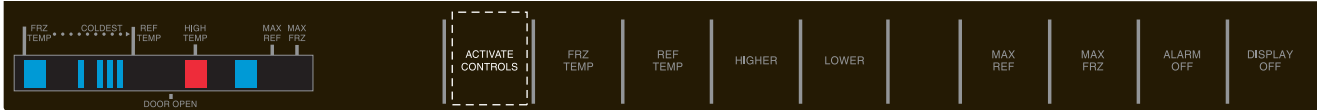

Once in Program Mode B, the following programmable functions can be achieved:

- Automatic Keyboard Functions
- Door Alarm Delay
- Adjust MAX REF run time
- Adjust MAX FRZ run time
- Temp offset Calibration
- Defrost mode select

### Automatic Keyboard Functions

Pressing “DISPLAY OFF” pad toggles between active and inactive keyboard. If high temperature indicator glows, all pads (keys) except “ALARM OFF” and “ACTIVATE CONTROLS” will be disabled after 10 minutes. If high temperature indicator is off, all pads (keys) on the keyboard are always enabled. **DO NOT LEAVE KEYBOARD IN ENABLED MODE AFTER PROGRAMMING IS COMPLETE.**

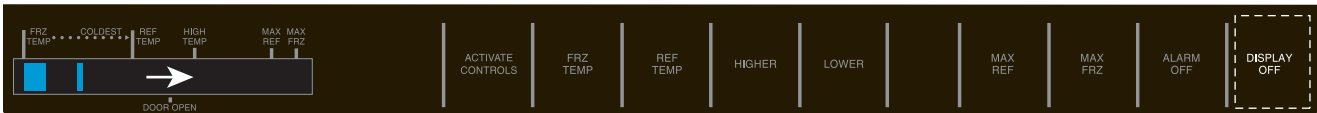
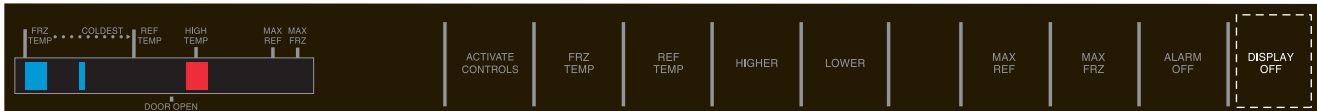

## Mode B Functions (continued)

### Door Alarm Delay

Press "ALARM OFF" pad. Door open indicator will glow. One temperature indicator should glow indicating present delay setting. Indicator light one glowing means one minute, indicator light two glowing means two minutes, etc. The default setting is 3 minutes.



To increase the default delay time, press "LOWER TEMP" pad to increase by one minute.

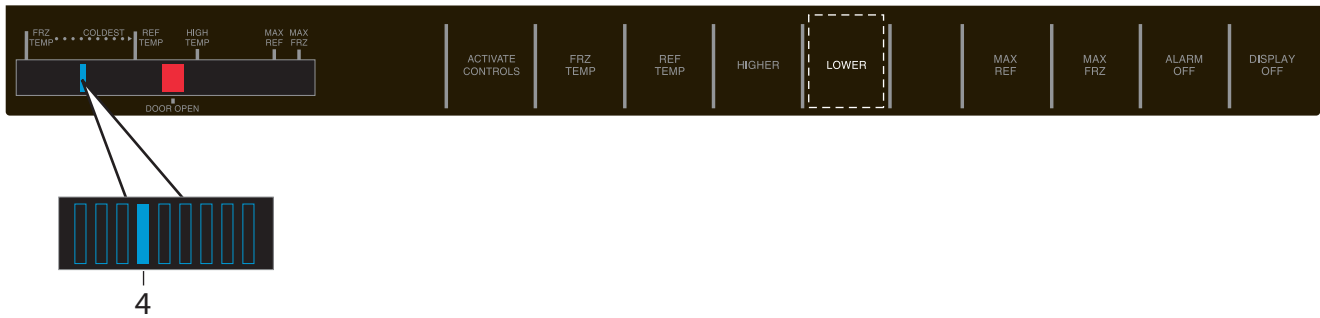

To decrease the default delay time press "HIGHER TEMP" pad to decrease by one minute.

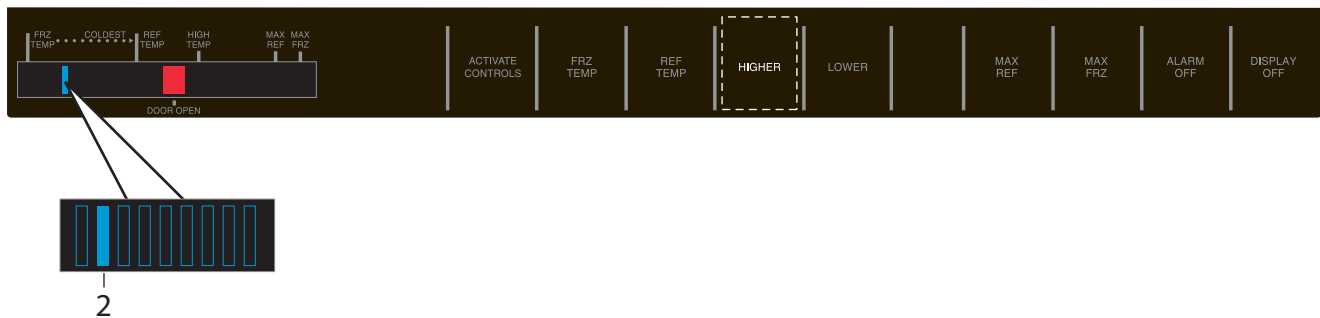

The indicator light and corresponding default times are listed below.

Indicator	1	2	<b>3*</b>	4	5	6	7	8	9
Default Delay Time	1 min	2 min	<b>3 min</b>	4 min	5 min	6 min	7 min	8 min	9 min

\* *Default setting*

## Mode B Functions (continued)

### Max Ref Run Time Duration

Press "MAX REF" pad. MAX REF light will glow. One temperature indicator should glow indicating present Max Ref run time duration in two hour increments. Indicator light one glowing means 4 hours, indicator light 2 glowing means 6 hours, etc. The default duration is 4 hours.

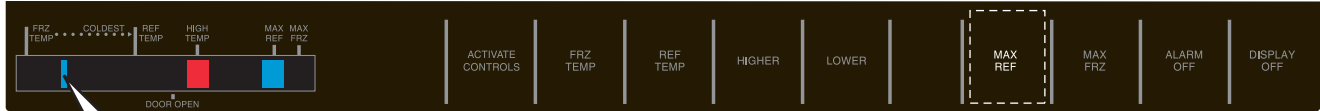

2

To increase the default Max Ref duration, press "LOWER TEMP" pad to increase duration by two hours.

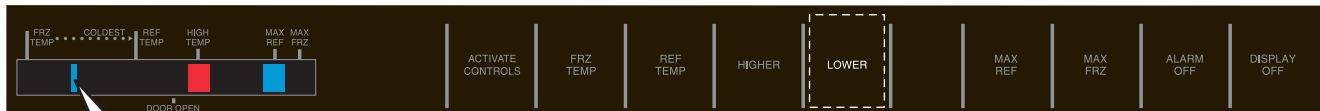

3

To decrease the default Max Ref duration, press "HIGHER TEMP" pad to decrease duration by two hours.

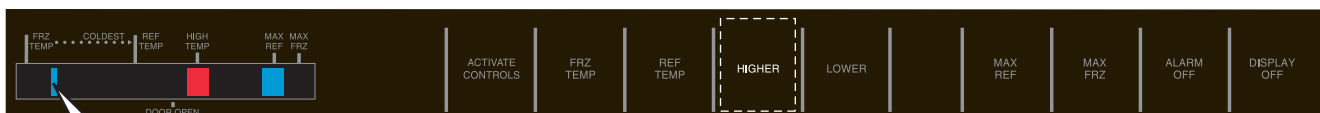

1

The indicator light and corresponding Max Ref run time duration are listed below.

Indicator	1*	2	3	4	5	6	7	8	9
Max Ref Run Time Duration	4 hrs	6 hrs	8 hrs	10 hrs	12 hrs	14 hrs	16 hrs	18 hrs	20 hrs

\* Default setting

## Mode B Functions (continued)

### Max Frz Run Time Duration

Press "MAX FRZ" pad. Max Frz light will glow. One temperature indicator should glow indicating present Max Frz run time duration in two hour increments. Indicator light one glowing means 4 hours, indicator light 2 glowing means 6 hours, etc. The default duration is 4 hours.

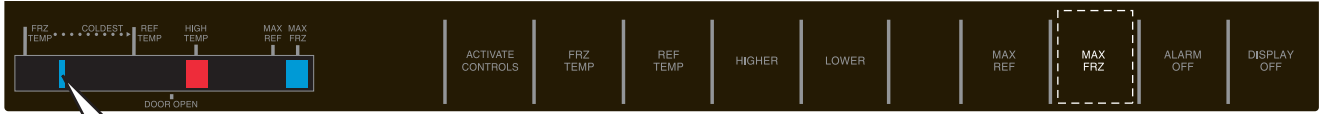

2

To increase the default Max Frz duration, press "LOWER TEMP" pad to increase duration by two hours.

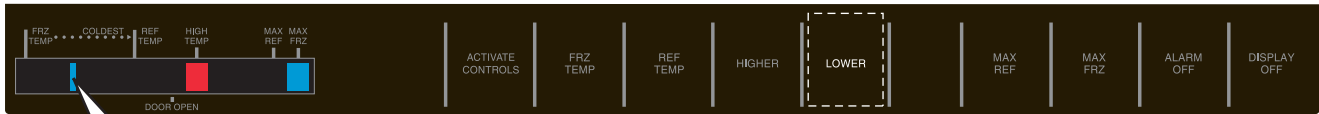

3

To decrease the default Max Frz duration, press "HIGHER TEMP" pad to decrease duration by two hours.

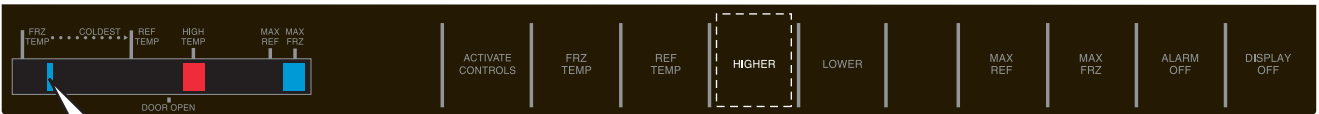

1

The indicator light and corresponding Max Frz run time duration are listed below.

Indicator	1*	2	3	4	5	6	7	8	9
Max Frz Run Time Duration	4 hrs	6 hrs	8 hrs	10 hrs	12 hrs	14 hrs	16 hrs	18 hrs	20 hrs

\* Default setting

## Mode B Functions (continued)

### Temperature Offset Calibration

The default setting for the Fresh Food Thermistor on a new unit depends on the type of Side-by-Side. A 48" dispenser model is indicator 4, a 42" dispenser model and a 48" non-dispenser model is indicator 6, and a 42" non-dispenser model is indicator 7. A replacement Low Voltage Board comes set with a default of 8. The offset must be changed to factory default for proper operation. The chart below shows the proper offset settings for the various Side-by-Side models for the Fresh Food Thermistor.

Indicator	1	2	3	4	5	6	7	8	Coldest
Offset	+8	+6	+4	+2	0	-2	-4	-6	-8
				48"D		42"D 48"	42"		

### Refrigerator Temperature Offset Calibration

Press "Ref Temp" pad to enter temperature offset. Ref Temp indicator will illuminate and one indicator bar will illuminate. The factory default setting is 4, 6, or 7 depending on the type of Side-by-Side model.

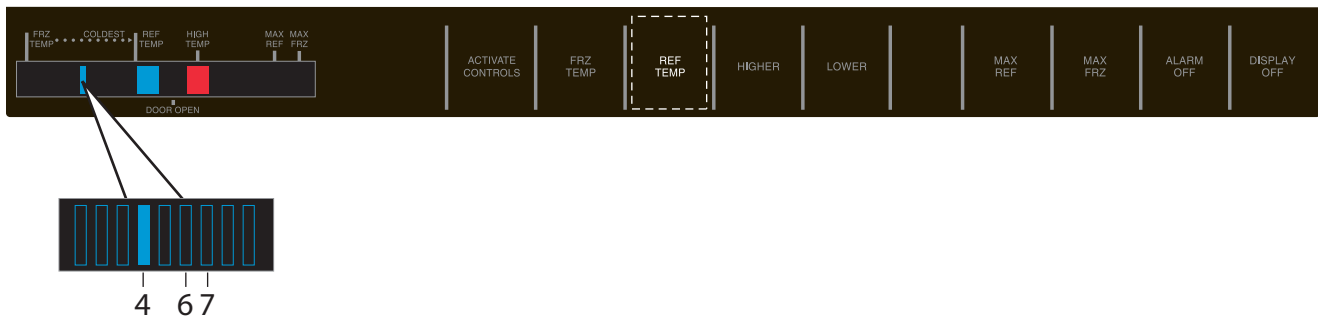

If the proper Offset is not programmed, press the Higher or Lower pad to the proper Offset setting. The chart above shows the correct indicator depending on the type of Side-by-Side model.

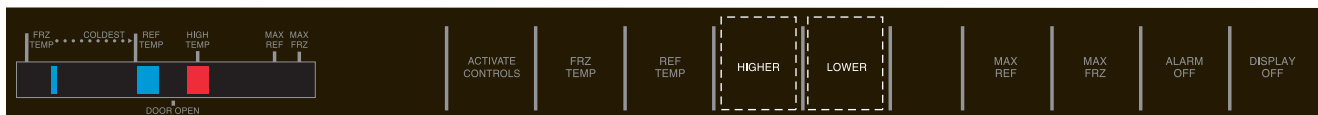

## Mode B Functions (continued)

### Freezer Temperature Offset Calibration

The default setting for the freezer thermistor on a new unit depends on the type of Side-by-Side unit. A 42" and 48" dispenser model is indicator 3 while a 42" and 48" non-dispenser model is indicator 4. A replacement Low Voltage Board comes set with a default of 5. If the settings are incorrect, it will need to be changed for proper operation.

The chart below shows the proper offset settings for the various Side-by-Side models for the Freezer Thermistor.

Indicator	1	2	3	4	5	6	7	8	Coldest
Offset	+8	+6	+4	+2	0	-2	-4	-6	-8
			48"D 42"D	48" 42"					

In Service Mode B, the Frz temp light will be illuminated. Depending on the type of Side-by-Side; bar 3 or 4 will be illuminated. The High Temp and the blue LED to the left of the Max Ref indicator will be illuminated.



If the proper offset setting for the model being serviced is not correct, use the Higher or Lower pad to set the proper Freezer Offset as shown in the chart above.

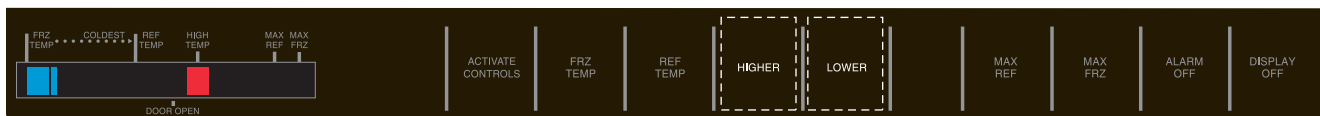



## Mode B Functions (continued)

### Defrost Mode Selection

Toggle between adaptive and conventional defrost mode by pressing "HIDDEN BUTTON" pad. If the blue LED to the left of the MAX REF Indicator is "ON", then the Adaptive Defrost is activated (Factory Default Setting).

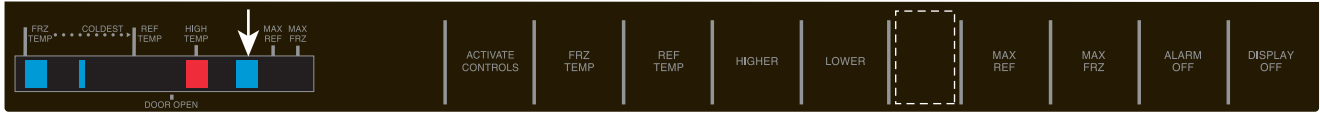

If the blue LED to the left of the MAX REF Indicator is "OFF", conventional defrost is selected. Conventional Defrost time is adjusted in SERVICE MODE A. Refer to page 24 for settings. The factory default is 8 hours (4th Bar).

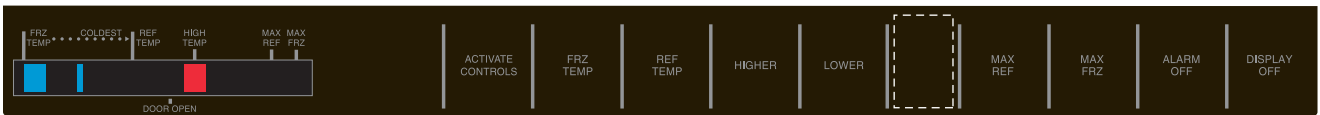

### Forced Defrost

Defrost can be forced to start by pressing and holding the "ALARM OFF" pad for 3 seconds. Program will be saved permanently in EEPROM and program mode will exit to Run Mode. If Defrost terminator is closed, the defrost heater will now operate.

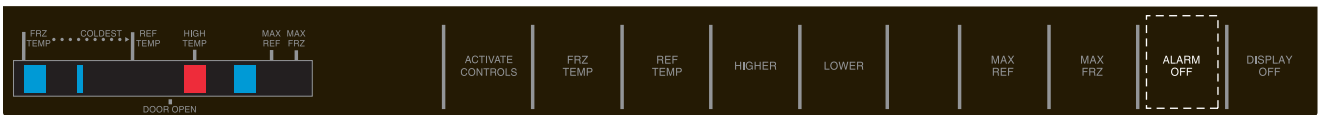

### Forced Compressor Start

Compressor start can be forced by pressing and holding "MAX FRZ" pad for three seconds. Program changes will be saved permanently in EEPROM. Compressor, evaporator fan, and condenser fan will come on.

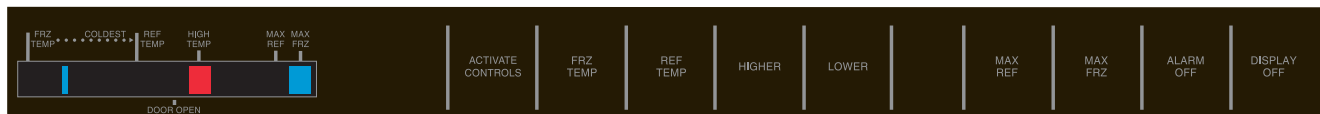
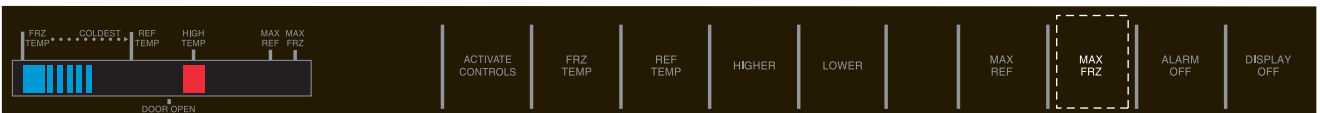

## Mode B Functions (continued)

### Exiting Program Mode

Press "ACTIVATE CONTROLS" for 3 seconds to exit Program Mode. An audible tone will sound three times indicating Program Mode has been exited. Changes made in Program Mode will be permanently saved in EEPROM.

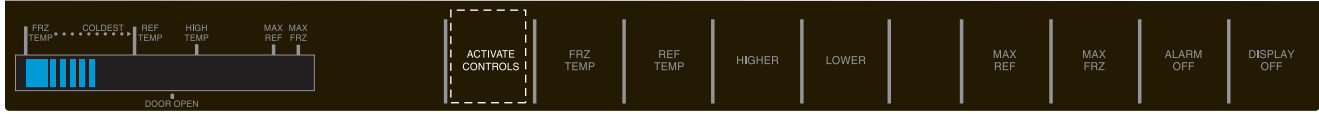

**Note:** If no pad is pressed for 10 minutes, Program Mode will automatically exit. However, no changes will be saved if Program Mode exits automatically.

The following features do not require entry into the service mode and can be performed by the consumer.

### Special Features

#### Forced Defrost Start

Press "ACTIVATE CONTROLS" pad. Press and hold "MAX REF" and "DISPLAY OFF" for 3 seconds.

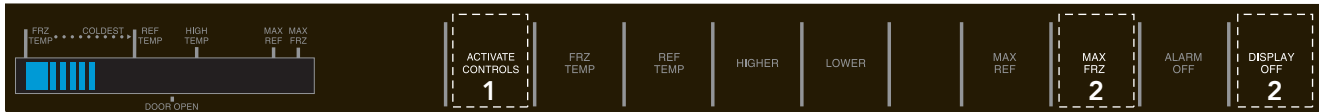

#### Forced Compressor Start

Press "ACTIVATE CONTROLS" pad. Press and hold either "MAX FRZ" or "ALARM OFF" pad and "DISPLAY OFF" pad for 3 seconds.

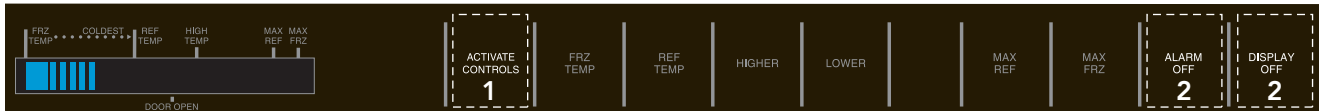

#### Open Thermistor Detect

Alarm sounds and freezer or refrigerator indicator light illuminates and temperature indicators 4 through 7 will turn on in sequence if either thermistor circuit opens. Refer to *Temperature Control Section* and *Electronic Testing section*.

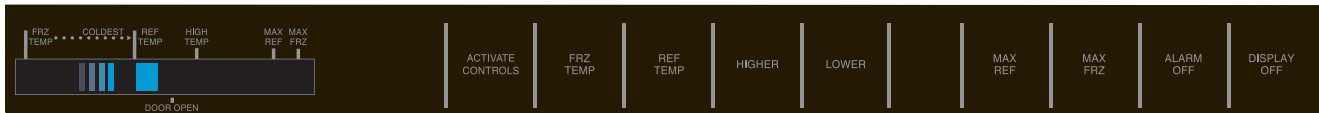

Press "ALARM OFF" pad to turn off alarm. Alarm will reset for normal operation. If condition has not been corrected, alarm will sound again.

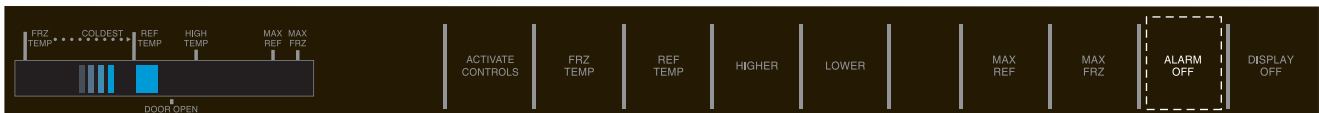

## Special Features (continued)

### Enter Showroom Mode

To enter Showroom mode: Press and hold the “ACTIVATE CONTROLS” pad. While holding, press and hold the “HIGHER” and “ALARM OFF” pad simultaneously. One beep will be heard indicating that sequence was entered properly.

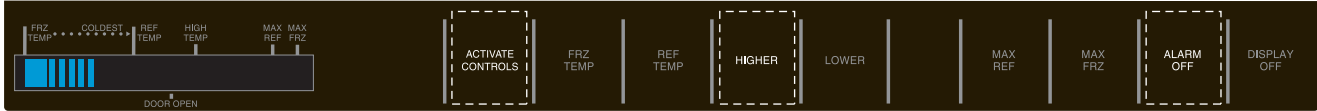

Continue holding until three beeps are heard and then the blue LED two steps to the right of the HIGH TEMP indicator will illuminate. Showroom mode activated. Showroom mode is entered.

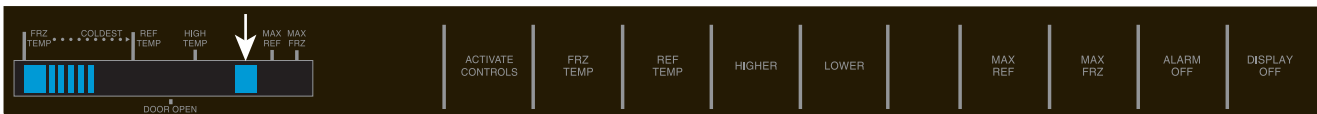

When the control is in Showroom Mode, the compressor/condenser fan, evaporator fan, DC fan, and defrost heater switches remain disabled. The keyboard, display, and interior lights operate as normal. Interior lights turn off 10 minutes after feature is enabled and High Temperature and Open Thermistor Alarms are disabled.

### Exit Showroom Mode

To exit Showroom mode: Press and hold the “ACTIVATE CONTROLS” pad. While holding, press and hold the “HIGHER” and “ALARM OFF” pad simultaneously. One beep will be heard indicating that sequence was entered properly.

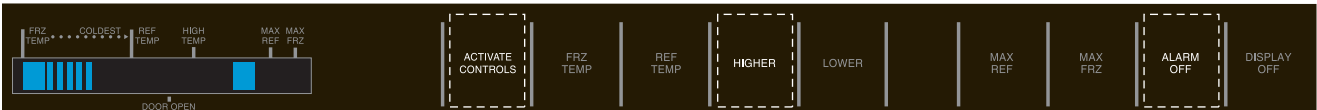

Continue holding until three beeps are heard. The display will revert to normal operation.

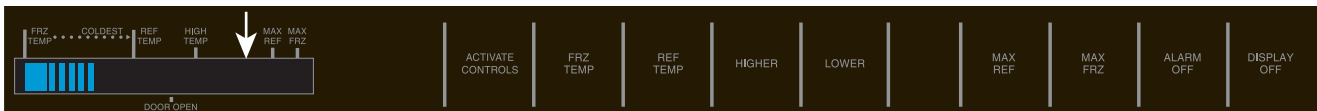

## Special Features (continued)

### Sabbath Mode Feature for Sabbath Observance

Before the Sabbath mode is engaged, the bale arm of the ice maker needs to be raised until it clicks into the detent. This turns off the power to the ice maker.

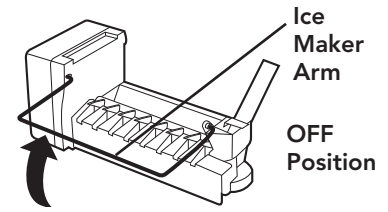

### Enter Sabbath Mode

To enter Sabbath mode, press the "ACTIVATE CONTROLS" pad to activate the control panel. Then, press and hold "ACTIVATE CONTROLS" and "DISPLAY OFF" pads simultaneously for three seconds.

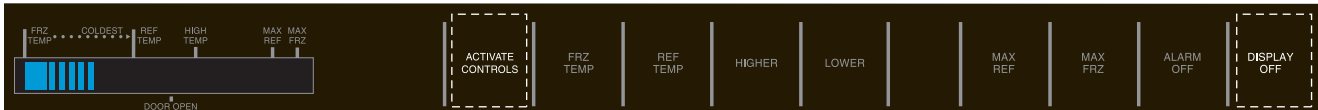

The control will beep three times and illuminate the 3 right blue squares to alert the user that Sabbath Mode has been entered. When the control enters Sabbath Mode, it will disable the interior lights, display (excluding the 3 right hand blue squares), and alarm enunciators.

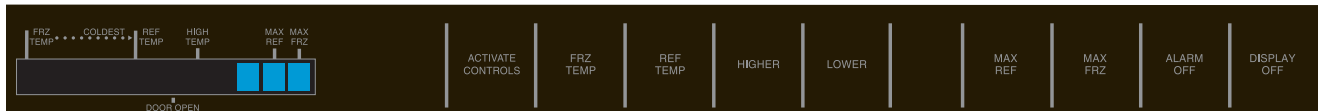

### Power Loss

If power loss occurs in Sabbath Mode and the control experiences a long power loss, it will return to Sabbath Mode when power is regained.

### Exit Sabbath Mode

To exit Sabbath Mode the user must press and hold "ACTIVATE CONTROLS" and "DISPLAY OFF" for 3 seconds.

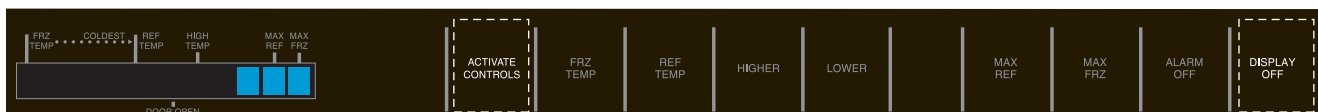

The control will beep three times alerting the user that Sabbath Mode has been exited. The control will return to normal mode.

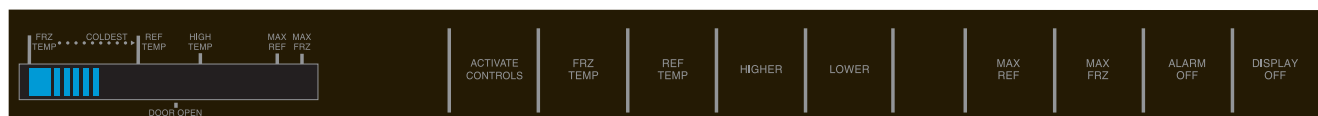

Once the unit is back in normal mode, the bale arm of the ice maker needs to be pushed down until it is no longer in the detent position. This will restore power to the ice maker.

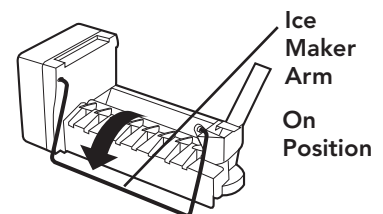

## Special Features (continued)

### Power Disconnect Switch

Use power disconnect switch to disconnect power without unplugging unit. Switch is located behind air grille in top right corner.

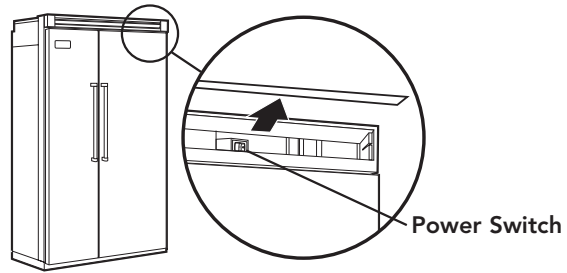

### Power Up Alarm

After Power is initially plugged in, after a power loss, or if power disconnect switch is turned "OFF", all temperature indicator lights will flash until "ALARM OFF" or "ACTIVATE CONTROLS" is pressed.

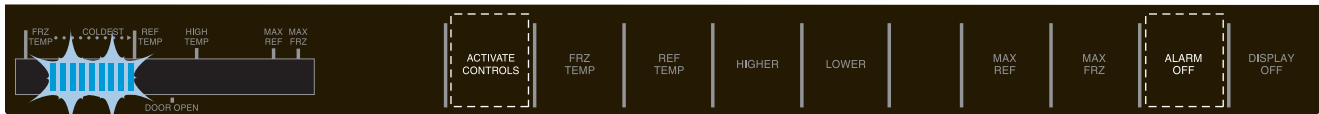

### Door Open Alarm

Alarm tone sounds and indicator lights blink if door is open for more than 3 minutes. To turn off Door Open Alarm, press "ALARM OFF" pad or close door.

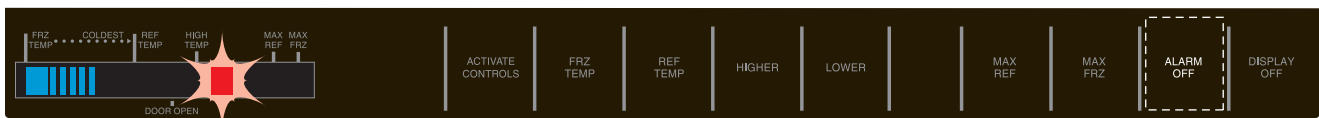

To deactivate Door Open Alarm by pressing "ACTIVATE CONTROLS" pad and then press and hold "ALARM OFF" pad for three seconds.

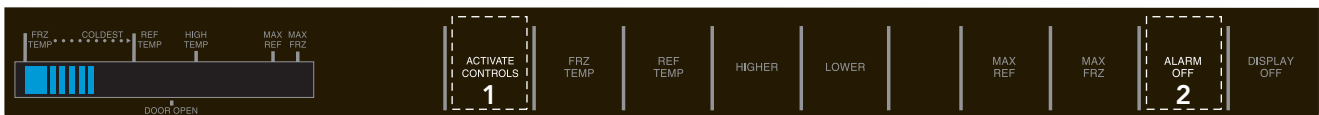

Door alarm delay can be adjusted in Program Mode B.

### High Temperature Alarm

When the controller detects critical temperature in the unit for a duration of 2 hours, an alarm will sound. A high temperature indicator light and a flashing freezer or refrigerator indicator light will accompany the audible alarm. Alarm tone stops if temperature falls again.

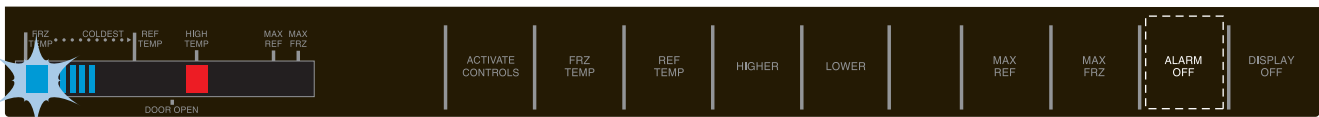

Press "ALARM OFF" pad to turn alarm off.

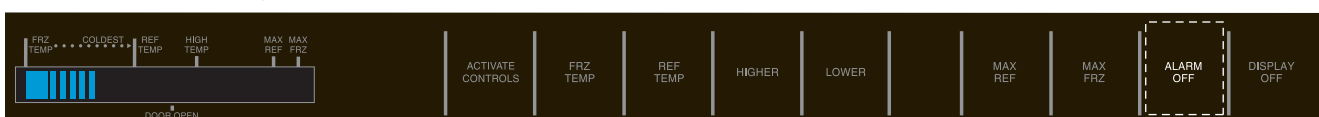

## Temperature Control Operation

For any temperature setting, outputs will be turned off/on based on cut-in/cut-out temperature determined by resistance levels of freezer or refrigerator thermistors.

### Refrigerator and Freezer Thermistor (NTC)

The refrigerator and freezer thermistors are NTC (Negative Temperature Coefficients) meaning as temperature decreases thermistor resistance increases and as temperature increases thermistor resistance decreases.

**Note:** Open thermistor or thermistor circuit will result in failure of refrigerator to cool. Shorted thermistor will cause refrigerator to run 100 percent of time except during defrost cycle.

Deg F	Deg C	K-Ohms
-24	-31	565
-22	-30	531
-20	-29	499
-18	-28	469
-16	-27	441
-15	-26	415
-13	-26	391
-11	-24	368
-9	-23	347
-8	-22	327
-6	-21	308
-4	-20	291
-2	-19	274
0	-18	259
1	-17	245
3	-16	231
5	-15	218
7	-14	206
9	-13	195

Deg F	Deg C	K-Ohms
10	-12	185
12	-11	175
14	-10	165
16	-9	157
18	-8	148
19	-7	141
21	-6	133
23	-5	126
25	-4	120
27	-3	114
28	-2	108
30	-1	103
32	0	97
34	1	93
36	2	88
37	3	84
39	4	80
41	5	76
43	6	72

Deg F	Deg C	K-Ohms
45	7	69
46	8	65
48	9	62
50	10	59
52	11	56
54	12	54
55	13	51
57	14	49
59	15	47
61	16	44
63	17	42
64	18	41
66	19	39
68	20	37
70	21	35
72	22	34
73	23	32
77	24	31
77	25	30

## Temperature Control Operation (continued)

Open thermistor or thermistor circuit will result in failure to cool. Shorted thermistor will cause refrigerator to run 100 percent of time except for defrost cycle. Freezer temperature setting and thermistor value will determine if compressor/condenser fan and evaporator fan switches are open or closed. Compressor/condenser fan switch must be open for 6 minutes before switch can close again (compressor dwell time). Refrigerator temperature setting and thermistor value will determine if fresh food switch is open or closed. Cut-out and cut-in temperature values must be reached and maintained for 15 seconds before output state will change (digital delay). Refrigerator and freezer control calibration can be adjusted in Program Mode B.

Cut-Out °F (°C) +/- 1.5°	Cut-Out °F (°C) +/- 1.5°	Cut-Out °F (°C) +/- 1.5°	Cut-Out °F (°C) +/- 1.5°	Level
-12 (-24)	3 (-16)	25 (-3.9)	37 (2.8)	9
-10 (-23)	5 (-15)	27 (-2.8)	39 (3.9)	8
-8 (-22)	7 (-14)	29 (-1.7)	41 (5.0)	7
-7 (-22)	8 (-13)	30 (-1.1)	42 (5.4)	6
-6 (-21)	9 (-13)	31 (-0.6)	43 (6.1)	5
-5 (-21)	10 (-12)	32 (-0)	44 (6.6)	4
-4 (-20)	11 (-12)	33 (-0)	45 (7.2)	3
-2 (-19)	13 (-11)	35 (1.7)	47 (8.3)	2
0 (-18)	15 (-9)	37 (2.8)	49 (9.4)	1
-12 (-24)	3 (-16)			Max Frz
		25 (-3.9)	37 (2.8)	Max Ref

## VCC3 Diagnostic Codes

1 Flash	No failure detected
2 Flashes	No signal from the control board
3 Flashes	Inverter failure
4 Flashes	Compressor failure

## Flashing cycles

1-flash code:	1 flash every 15 seconds
2-flash code:	2 flashes every 5 seconds
3-flash code:	3 flashes every 5 seconds
4-flash code	4 flashes every 5 seconds

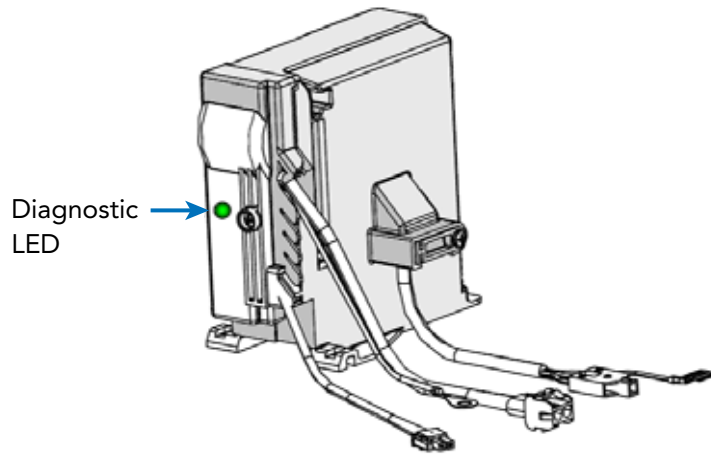

## Diagnostic Procedures

Code	Compressor Status	Probable Root Causes	Service Action
1 Flash—every 15 seconds	ON	<ul style="list-style-type: none"> <li>No failure detected</li> </ul>	If system is not working properly, check other refrigerator components
	OFF	<ul style="list-style-type: none"> <li>No signal from Control Board</li> <li>Open thermistor</li> </ul>	<p>If refrigerator settings (thermistor conditions) are at levels in which compressor status should be "ON":</p> <p><i>* Unplug inverter from power supply and wait for 2 minutes, reconnect the inverter to the power supply and wait for 12 minutes</i></p> <ul style="list-style-type: none"> <li>If inverter still shows 1 flash code and compressor is "OFF", then check the control board</li> </ul>
2 Flashes—every 5 seconds	OFF	<ul style="list-style-type: none"> <li>No signal from Control Board</li> </ul>	<ul style="list-style-type: none"> <li>Check frequency cable connection</li> <li>If frequency cable connection is OK, replace inverter</li> </ul>
3 Flashes—every 5 seconds	OFF	<ul style="list-style-type: none"> <li>Compressor/inverter cable interrupted (open circuit)</li> <li>Inverter damaged</li> <li>Compressor winding open circuit</li> </ul>	<ul style="list-style-type: none"> <li>Check inverter/compressor cable connection</li> <li>Check compressor winding resistances (among 3 terminal hermetic pins)</li> <li>If resistance is within specification and inverter/compressor cable is OK, replace inverter</li> </ul>



## Diagnostic Procedures (continued)

Code	Compressor Status	Probable Root Causes	Service Action
4 Flashes—every 5 seconds	OFF	<ul style="list-style-type: none"> <li>• Compressor damaged/ system damaged</li> </ul>	<ul style="list-style-type: none"> <li>• Check compressor input power</li> <li>• Check compressor windings resistances</li> <li>• Check leakage current between hermetic terminal pins and compressor shell</li> <li>• If resistance or leakage current is out of spec, replace the compressor</li> <li>• If resistance and leakage current are within the spec:                             <ul style="list-style-type: none"> <li>* <i>Check inverter/compressor cable is interrupted</i></li> <li>* <i>Unplug inverter from power supply and wait for 2 minutes</i></li> <li>* <i>Reconnect the inverter to the power supply and wait for 12 minutes</i></li> </ul> </li> <li>• If inverter still shows 4 flash code and compressor is "OFF", replace the compressor</li> </ul>
LED OFF	OFF	<ul style="list-style-type: none"> <li>• No input power signal— Inverter damaged</li> </ul>	<ul style="list-style-type: none"> <li>• Check the input power signal (115V)</li> <li>• If there is no signal, check the input power connections</li> <li>• If voltage is within specifications, unplug the inverter from the power supply and wait 2 minutes. Reconnect the inverter to the power supply and wait for 12 minutes</li> <li>• If inverter shows no flash code and compressor is "OFF", change the inverter</li> <li>• If the inverter shows no flash code and the compressor is "ON", diagnostic function is not working properly</li> </ul>

Parts Location–Control Panel

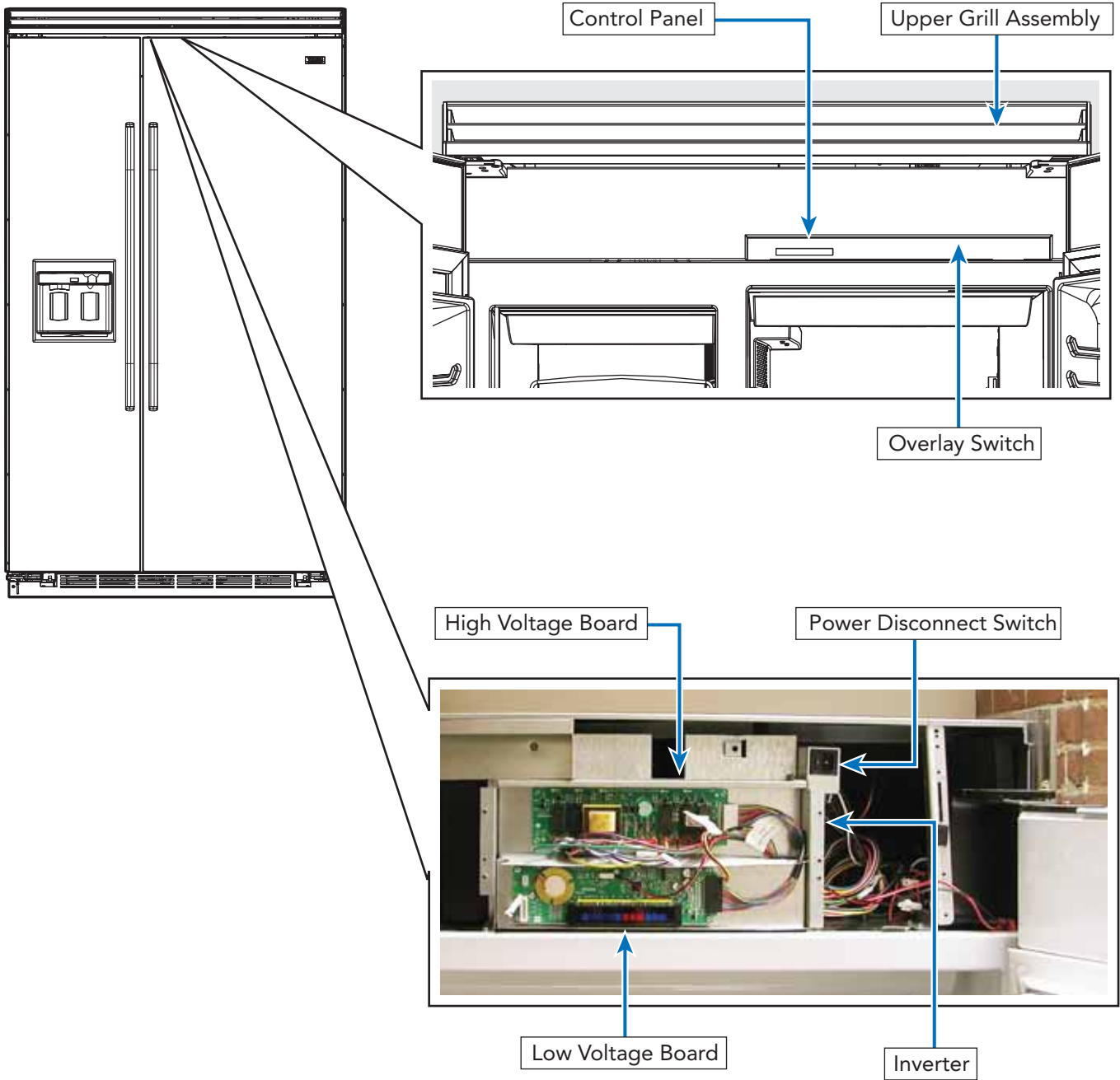

## ⚠ WARNING

To avoid risk of electrical shock, personal injury, or death, disconnect electrical power to unit using power switch before servicing. Wires removed during disassembly must be replaced on proper terminals to insure correct earth ground and polarization. After servicing, reconnect power using power switch.

### Upper Grill Assembly

Removal of the upper grill assembly allows access to the control assembly.

1. To remove the upper grill assembly, slide out the middle air louver.

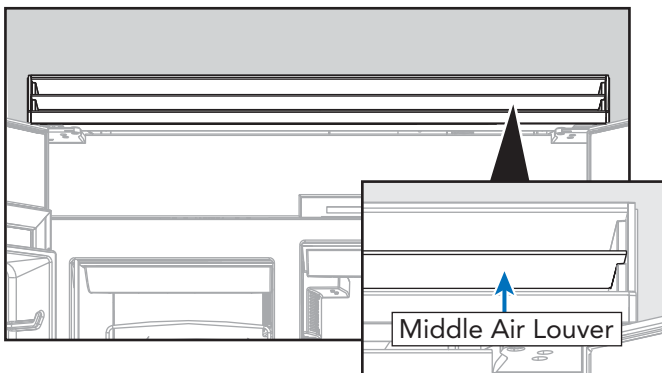

2. With the middle grill louver removed, remove (2) 1/4" hex screws securing the grill assembly.

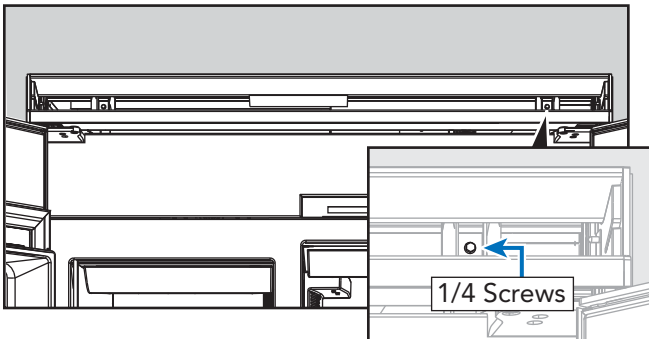

3. Remove the grill assembly.

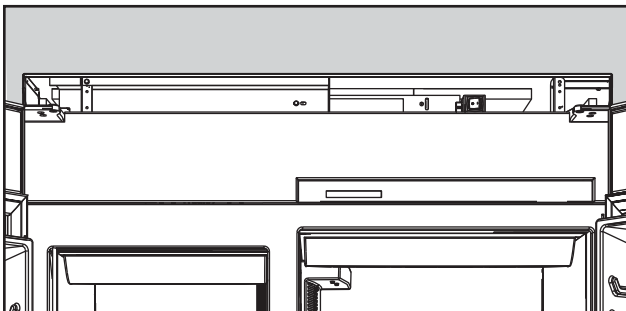

### Control Panel

The control panel has an overlay switch attached to it that allows user input to the control boards.

1. To access the control panel, remove the upper air grill assembly (see *Upper Grill Removal* section), remove (2) screws securing the control panel.

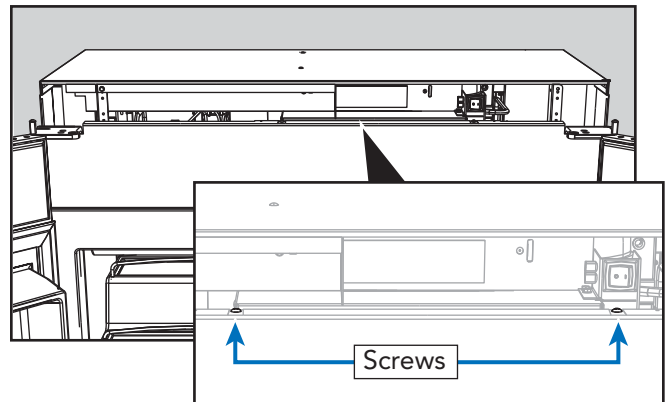

2. Pull control panel from securing tabs.

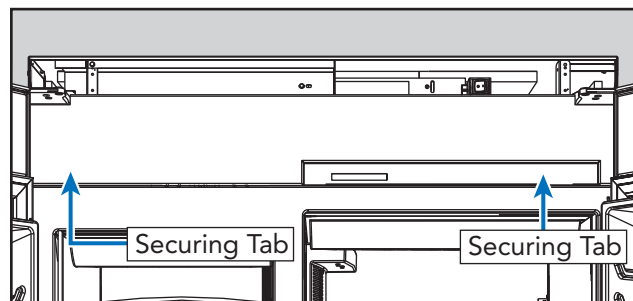

3. Lower the control panel. **Take caution with the ribbon cable to prevent damage.**

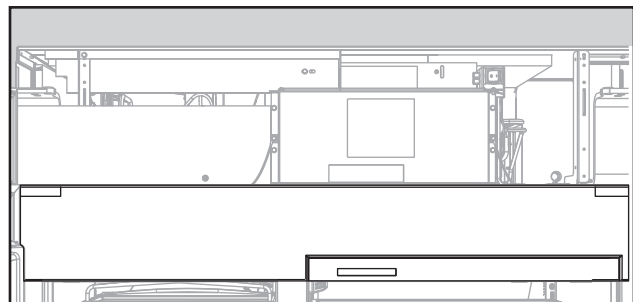

## ⚠ WARNING

To avoid risk of electrical shock, personal injury, or death, disconnect electrical power to unit using power switch before servicing. Wires removed during disassembly must be replaced on proper terminals to insure correct earth ground and polarization. After servicing, reconnect power using power switch.

### Control Panel (continued)

4. Remove the four screws securing the control board cover. Remove control board cover.



5. Disconnect the ribbon from the control board. **Take caution with the ribbon cable to prevent damage.**

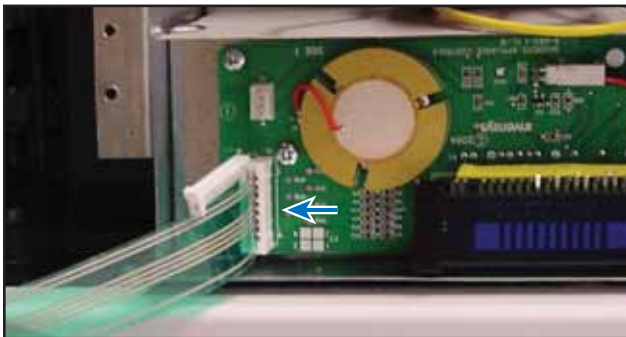

6. Remove the two strain relief screws.

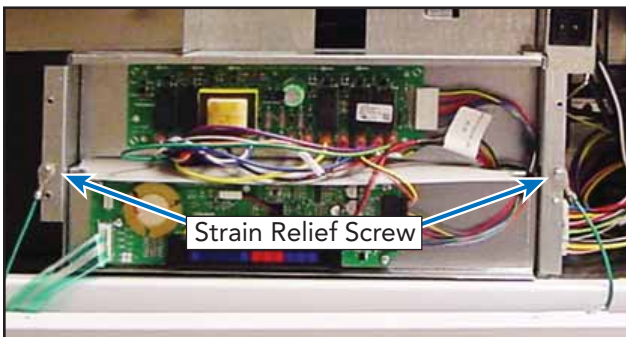

8. The control panel can now be removed and the high voltage and low voltage boards are accessible.

9. Reverse procedure to reinstall.

### Overlay Switch

The unit uses an overlay switch to communicate user input to the control boards. The overlay connects to the control board via a ribbon cable.

1. To replace the overlay switch, remove the upper air grill assembly, remove the control panel (see *Air Grill and Control Panel Removal* sections).

2. Disconnect overlay switch from control.

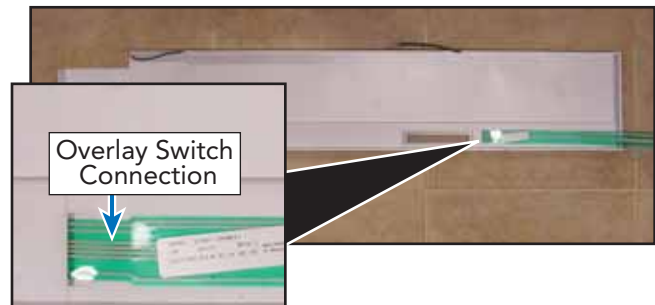

3. Peel overlay off control panel (remove adhesive to ensure replacement overlay adheres properly).

4. Reverse procedure to reinstall.

## ⚠ WARNING

To avoid risk of electrical shock, personal injury, or death, disconnect electrical power to unit using power switch before servicing. Wires removed during disassembly must be replaced on proper terminals to insure correct earth ground and polarization. After servicing, reconnect power using power switch.

### High Voltage Board

A control board is used to operate functions of the unit. Once an input is received from the low voltage board, the high voltage board sends an output to activate the components.

1. To access the high voltage board, remove the upper air grill assembly, and control panel (see *Air Grill and Control Panel Removal sections*).
2. Remove screws securing low voltage board, disconnect wiring and remove.

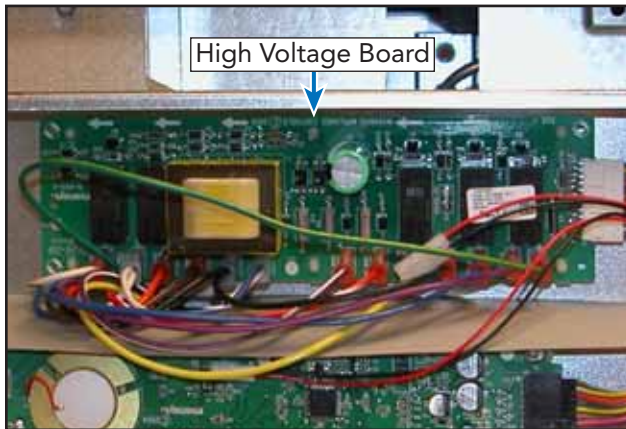

High voltage board is now accessible. To check high voltage board, refer to chart on page 46.

3. Reverse procedure to reinstall.

### Low Voltage Board

The unit uses a control board in conjunction with an overlay switch to operate functions of the refrigerator/freezer. Input comes to the low voltage board via the ribbon cable attached to the overlay switch.

1. To access the low voltage board, remove the upper air grill assembly, control panel (see *Air Grill and Control Panel Removal sections*).
2. Remove screws securing low voltage board disconnect wiring and remove.

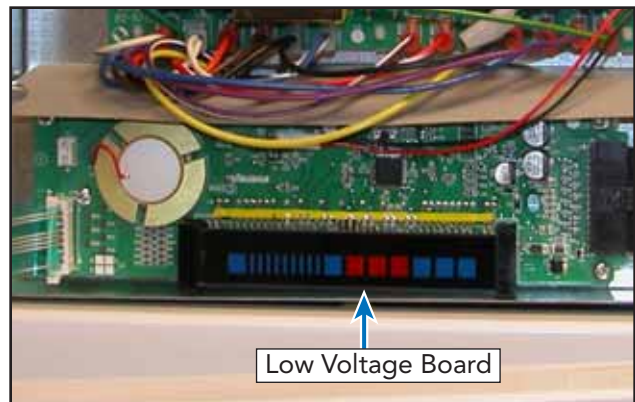

3. Reverse procedure to reinstall.

**⚠ WARNING**

To avoid risk of electrical shock, personal injury, or death, disconnect electrical power to unit using power switch before servicing. Wires removed during disassembly must be replaced on proper terminals to insure correct earth ground and polarization. After servicing, reconnect power using power switch.

**Component Testing–High Voltage Board**

High Voltage Board		
Component	Test Point	Reading
Refrigerator/Condensate Fans	E1-E11	24 VDC
Evaporator Fans	E2-E11	115 VAC
L1	E3-E11	115 VAC
Compressor/Condenser Fan	E4-E11	115 VAC
Defrost Terminator (Open)	E5-E11	0 VAC
Defrost Terminator (Closed)	E5-E11	115 VAC
Defrost Heater	E6-E11	115 VAC
Ref Door Switch (Top/Right Light)	E7-E11	115 VAC
Freezer Door Switch (Left Light)	E8-E11	115 VAC
Neutral In	E9-E11	N/A
Line In	E10-E11	115 VAC
Ground	E11	N/A
Neutral In-Lights	E12-E11	N/A
Neutral Out-Lights	E13-E11	115 VAC

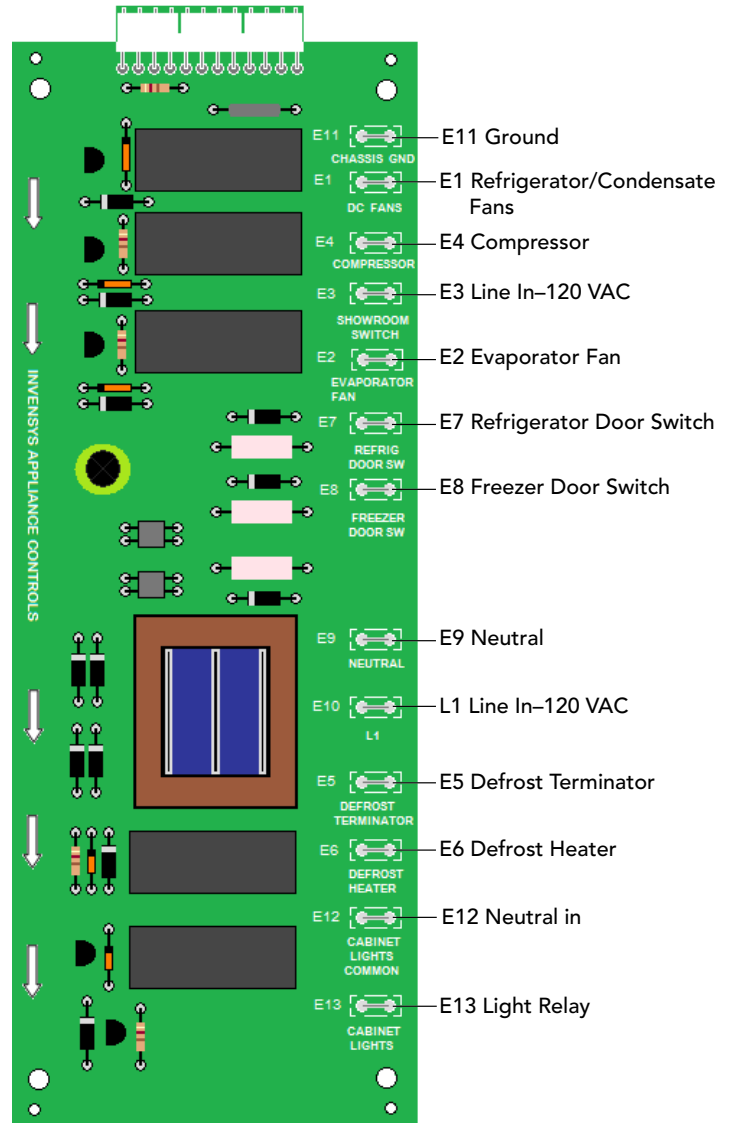

**! WARNING**

To avoid risk of electrical shock, personal injury, or death, disconnect electrical power to unit using power switch before servicing. Wires removed during disassembly must be replaced on proper terminals to insure correct earth ground and polarization. After servicing, reconnect power using power switch.

**Component Testing–Low Voltage Board**

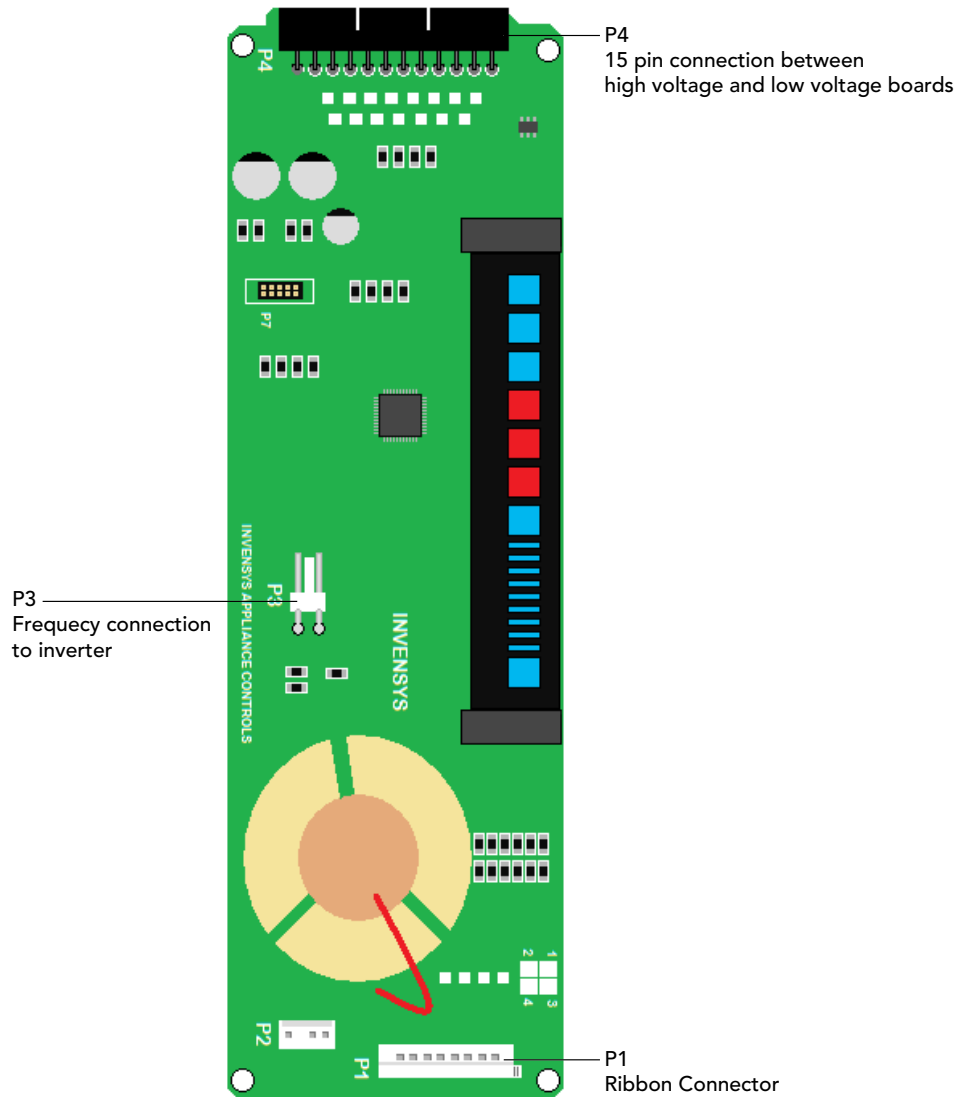



## ⚠ WARNING

To avoid risk of electrical shock, personal injury, or death, disconnect electrical power to unit using power switch before servicing. Wires removed during disassembly must be replaced on proper terminals to insure correct earth ground and polarization. After servicing, reconnect power using power switch.

### Power Disconnect Switch

The unit has a rocker switch, located in the upper right corner of the unit, that allows power to the unit to be turned "OFF" without removal of the unit.

1. To access the power disconnect switch, remove the upper air grill assembly (see *Air Grill Removal section*). The power disconnect is now accessible on the right side.



Verify contacts 4-5 open when the switch is in the "0" position and contacts 4-5 close when in the "I" position. 120 VAC should be measured when in the "0" position and 0 VAC should be measured when in the "I" position.

2. Reverse procedure to reinstall.

### Inverter

The Compressor is operated by a Inverter that varies the voltage to the compressor. This is determined by the frequency input from the low voltage board

1. To access the inverter, remove upper air grill assembly, remove control panel assembly (see *Air Grill and Control Panel Removal sections*).

2. Remove the control box in order to gain easy access to the door hinge area for service. There are 4-1/4" hex screws (2 on each side) holding the control box to the refrigerator housing. Remove these screws.

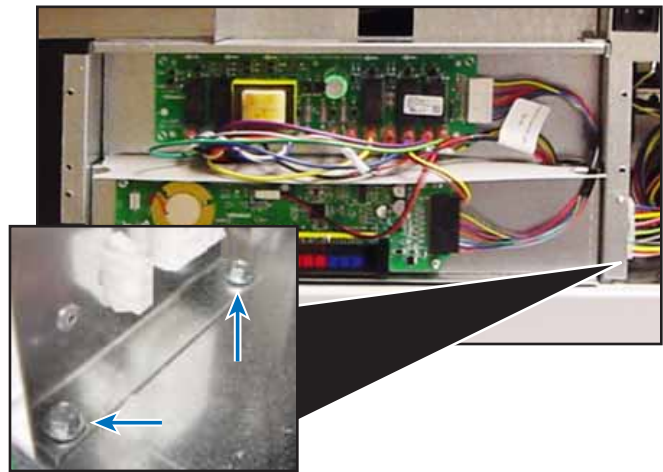

3. Unplug the 15-pin Molex power plug (A), as well as the 2-wire converter frequency cable (B) and the 3-wire thermistor plug (C).

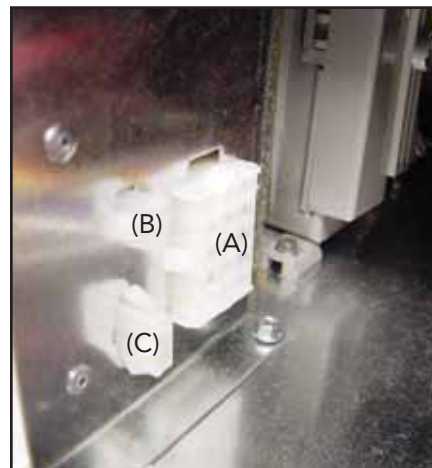



## ⚠ WARNING

To avoid risk of electrical shock, personal injury, or death, disconnect electrical power to unit using power switch before servicing. Wires removed during disassembly must be replaced on proper terminals to insure correct earth ground and polarization. After servicing, reconnect power using power switch.

### Inverter (continued)

4. The inverter is now accessible on the right side.

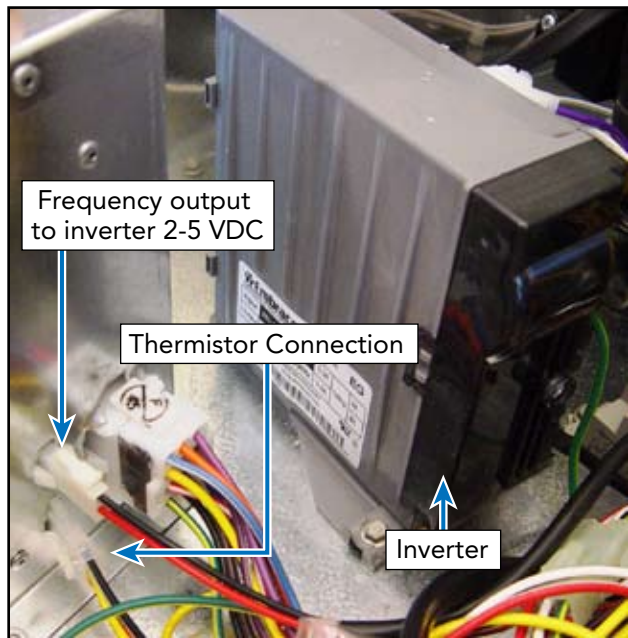

115 VAC is supplied to the inverter from E4 on the High Voltage Board. The LV board sends 2-5 VDC to the inverter to operate the compressor.

5. Reverse procedure to reinstall.

### Condenser Fan

The condenser fan is located in the upper machine compartment of the unit. 115 VAC is supplied to the fan when the Compressor/Condenser Fan relay closes to E4 on the High Voltage Board.

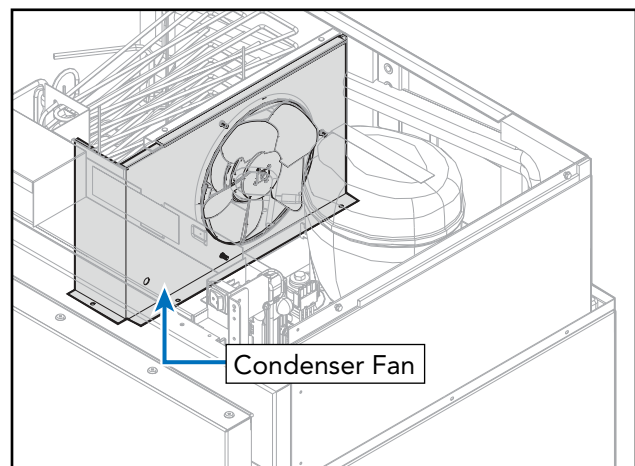

Parts Location–Refrigerator Compartment

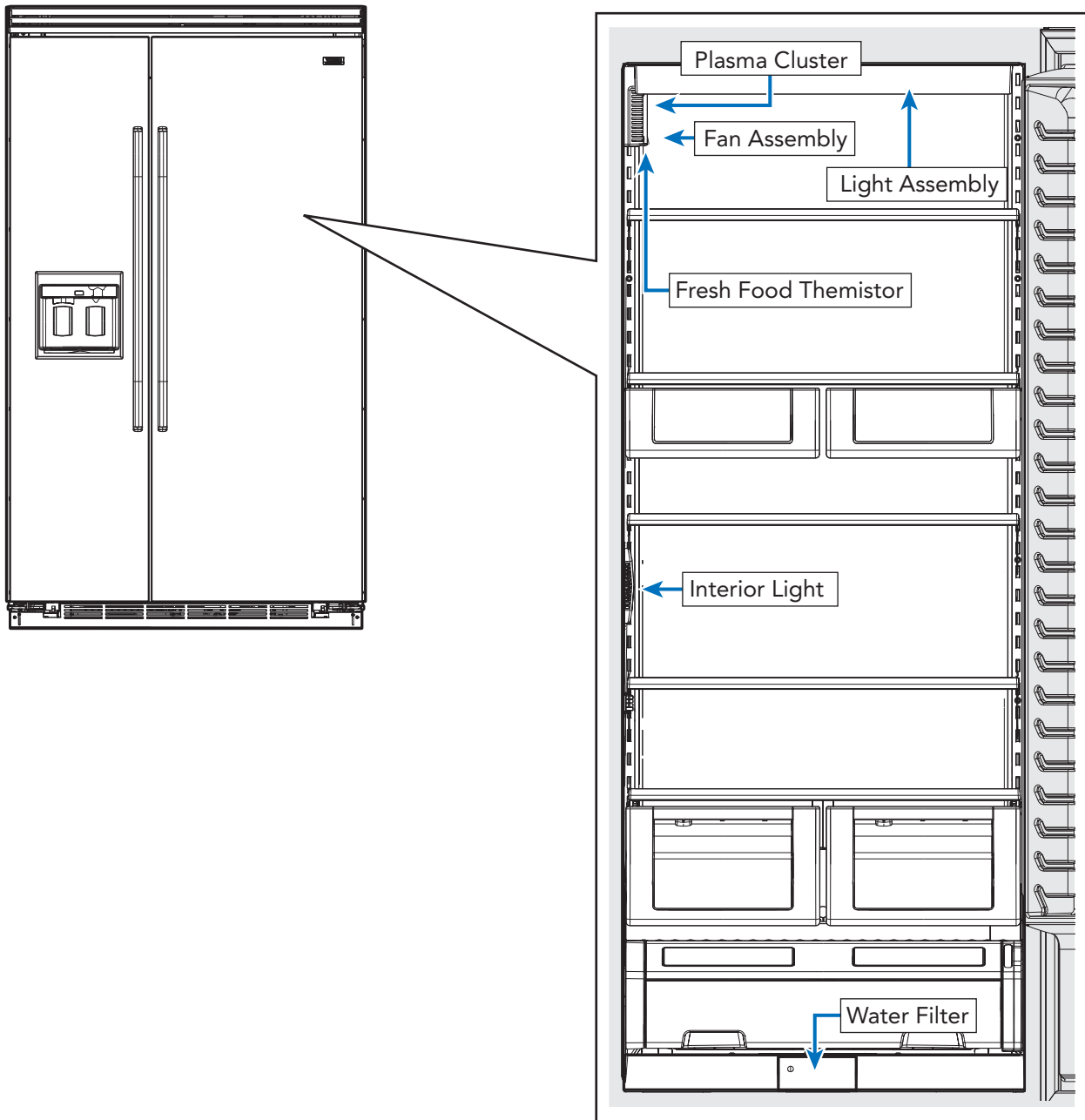

## ⚠ WARNING

To avoid risk of electrical shock, personal injury, or death, disconnect electrical power to unit using power switch before servicing. Wires removed during disassembly must be replaced on proper terminals to insure correct earth ground and polarization. After servicing, reconnect power using power switch.

### Light Assembly

The unit uses 40 watt bulbs to light the unit. The bulbs are located at the top of unit.

To access bulbs, remove light cover and bulb is accessible.

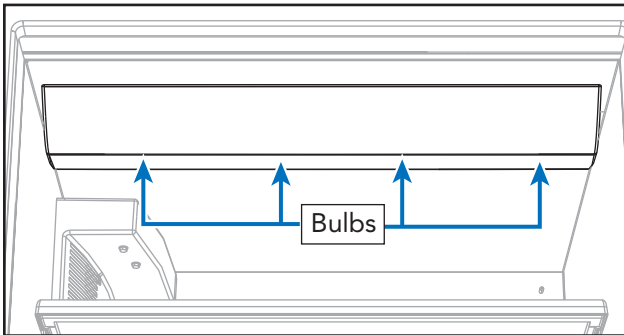

To check bulb, verify filament is not broken, the resistance in the bulb, and that voltage is supplied to the socket.

### Fresh Food Fan Assembly

The Side-by-Side units uses a fresh food fan to circulate air through the refrigerator compartment. The fresh food fan is wired in parallel with the cross over fan. When the board calls for the fan to operate, 24 VDC is sent to the fan via the E1 (Purple) at the H.V. Board.

1. To access the fan, open the refrigerator door and remove the upper shelf. Remove (2) screws securing fan cover.

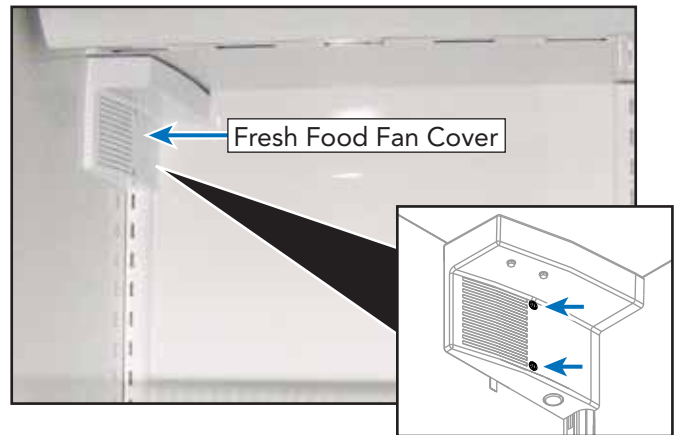

2. Lower fan cover to expose fresh food fan and disconnect wiring.

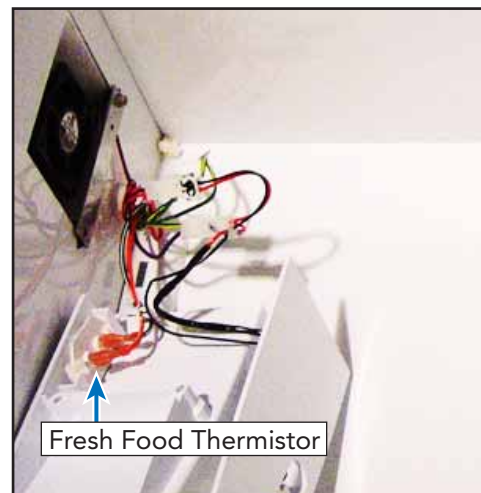

## ⚠ WARNING

To avoid risk of electrical shock, personal injury, or death, disconnect electrical power to unit using power switch before servicing. Wires removed during disassembly must be replaced on proper terminals to insure correct earth ground and polarization. After servicing, reconnect power using power switch.

### Fresh Food Fan Assembly (continued)

- Open freezer door and remove (2) screws securing air cover.

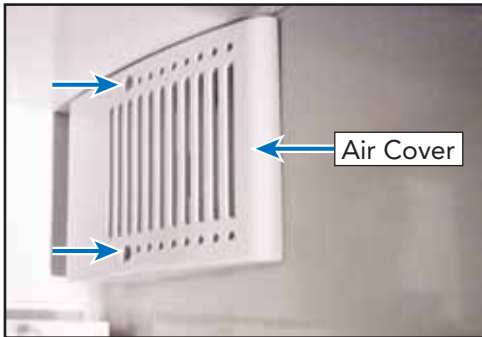

- Remove (2) screws securing fresh food fan and repair/replace fan.

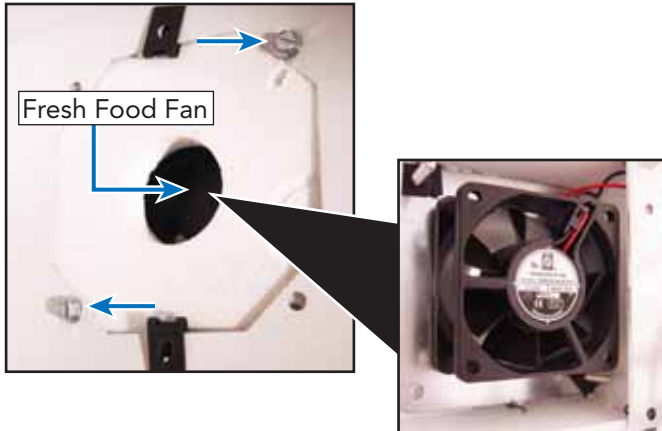

- Reverse procedure to reinstall.

### Interior Lights

The unit uses two lights, one in the fresh food section and one in the freezer section, to provide lighting for the cabinet.

- To access the light bulb, remove shelves.

- Remove light cover. The fresh food light cover is removed by pressing up on the bottom of cover while gently pulling out on the top of the cover to release the cover tab from the mounting plate. The freezer light cover is removed by pushing down on the top of the light cover while gently pulling out on the bottom of the cover to release the cover tab from the mounting plate.



- Remove the three securing screws to access the socket.



- Remove the light assembly and replace/repair the socket.
- Reverse procedure to reinstall.

**⚠ WARNING**

To avoid risk of electrical shock, personal injury, or death, disconnect electrical power to unit using power switch before servicing. Wires removed during disassembly must be replaced on proper terminals to insure correct earth ground and polarization. After servicing, reconnect power using power switch.

### Freezer and Fresh food Thermistor

Resistance of thermistors can be checked at the 3-pin Molex board as shown on page 47 or if necessary at the LV Board.

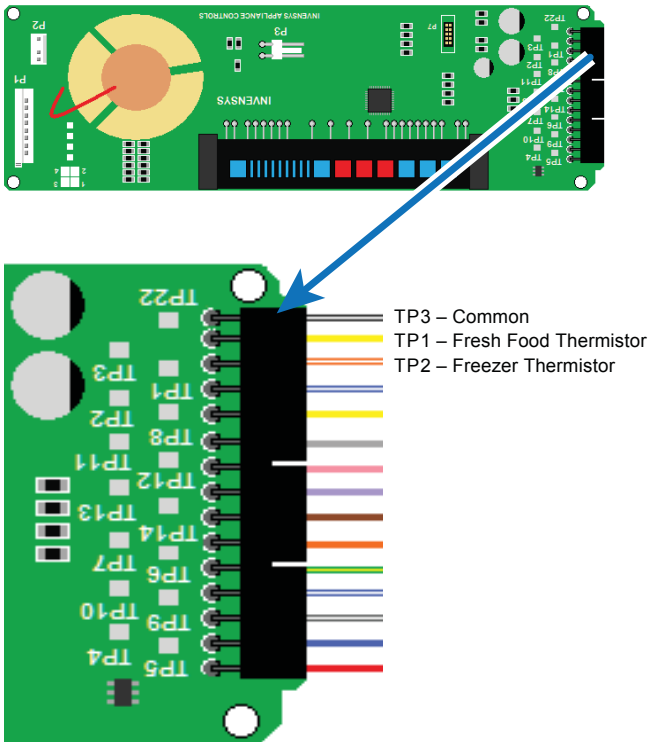

1. To access the thermistor remove fresh fan cover (see fresh food fan procedure).
2. With cover lowered, unsnap thermistor from cover, disconnect wiring and repair replace thermistor.

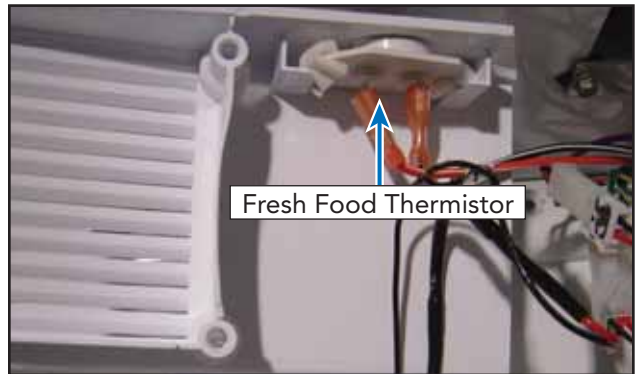

3. Reverse procedure to reinstall.

Top three wires are for Thermistors. Black with white tracer is common, Yellow with white tracer is the freezer thermistor, and Orange with white tracer is the fresh food thermistor. Both should read approximately 25 – 30 K-Ohms at ambient.

The unit uses a thermal device called a temperature thermistor. As the temperature in the compartment changes, the resistance in this device changes. These changes are measured by the low voltage board and controls operation of the fresh food fan. Refer to thermistor chart on page 38.

## ⚠ WARNING

To avoid risk of electrical shock, personal injury, or death, disconnect electrical power to unit using power switch before servicing. Wires removed during disassembly must be replaced on proper terminals to insure correct earth ground and polarization. After servicing, reconnect power using power switch.

### Plasma Cluster

The plasma cluster ion air purifier uses ions to eliminate airborne bacteria, mold spores, and food odors without having to be replaced.

1. To access the plasma cluster, remove air cover (see *fresh food fan procedure*).
2. With cover removed, remove the double sided tape securing the plasma cluster to the air cover, disconnect wiring, and repair/replace plasma cluster.



3. Reverse procedure to reinstall.

The Plasma Cluster is protected by a diode. Resistance readings should be 2.0 M  $\Omega$  in one direction and infinite ohms in the other.

### Water Filter

The Side-by-Side unit uses a water filter to remove contaminants from the water supplied to the end user.

To access the water filter:

1. Open the Fresh Food door, locate the filter door in the bottom center of the cabinet, and press in on filter door to open.

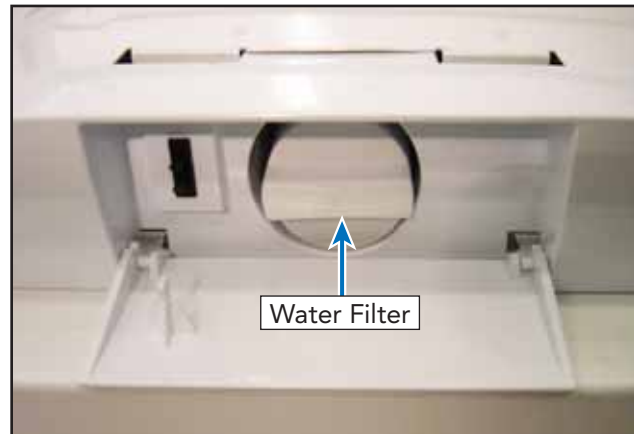

2. Turn the filter clockwise to release. Side pressure on the filter may be necessary to release the suction and allow filter removal.
3. Reverse procedure to reinstall.

Parts Location—Freezer Compartment and Lower Unit—Non Dispenser

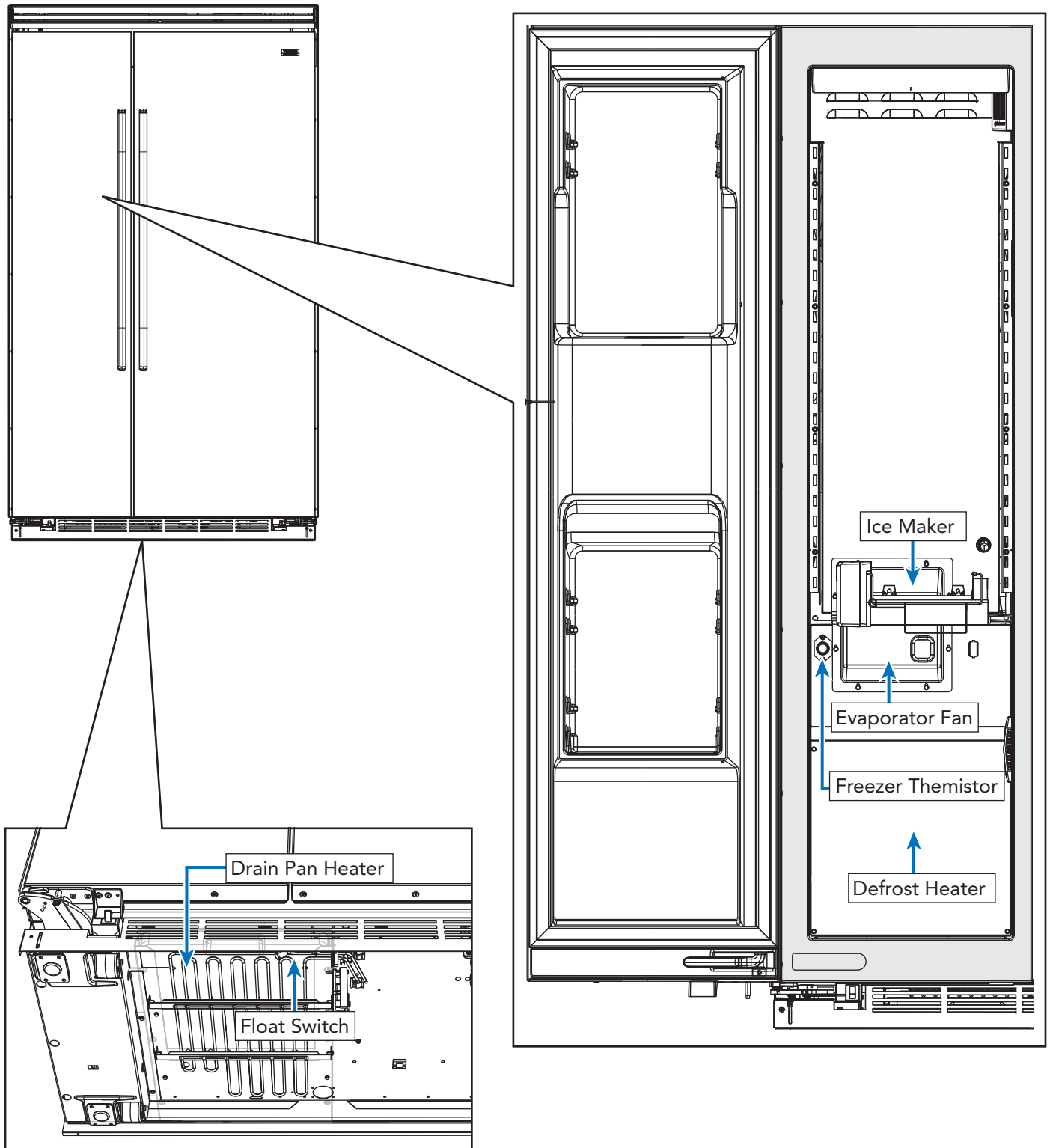



Parts Location—Freezer Compartment and Lower Unit—Dispenser

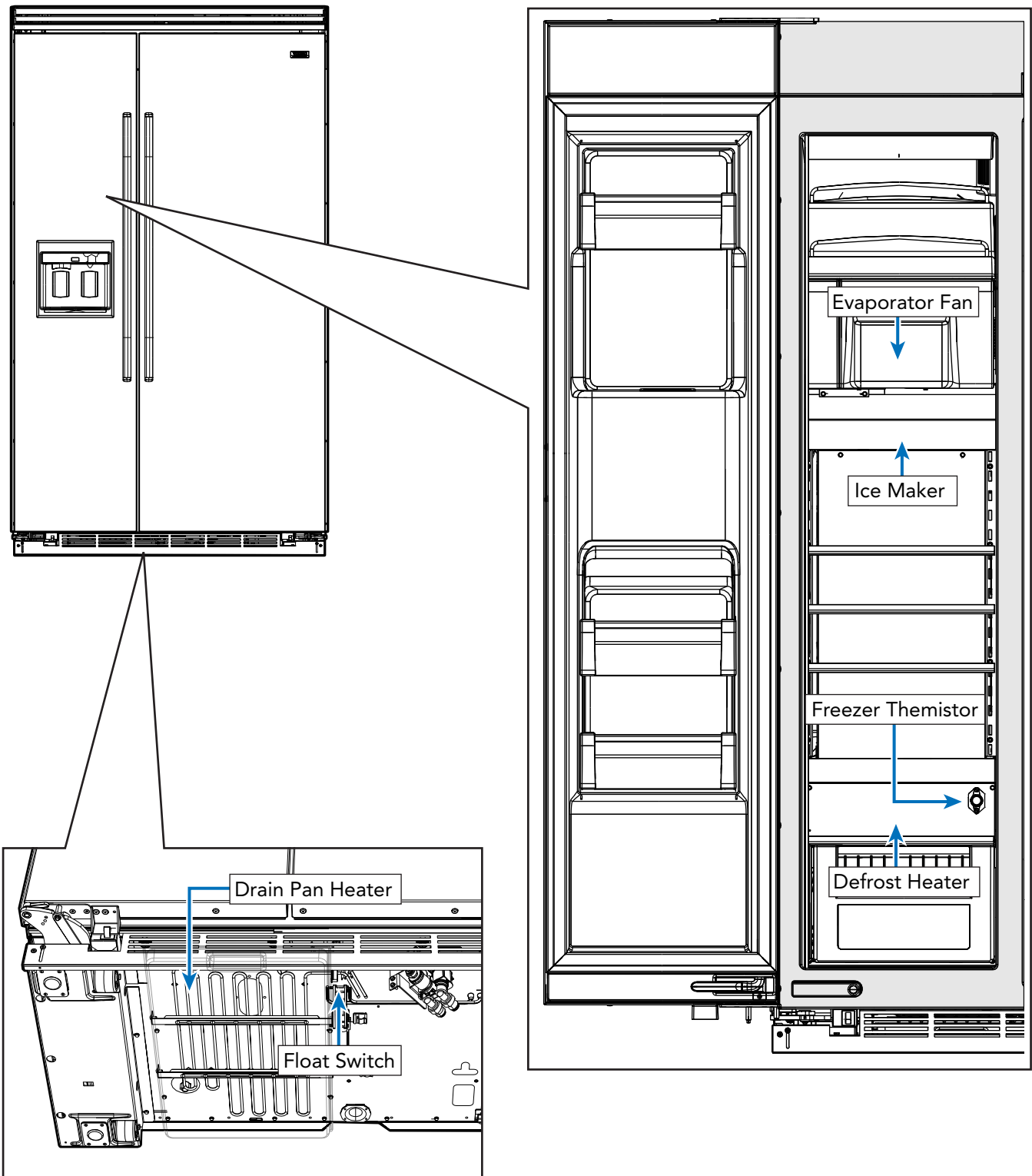



## ⚠ WARNING

To avoid risk of electrical shock, personal injury, or death, disconnect electrical power to unit using power switch before servicing. Wires removed during disassembly must be replaced on proper terminals to insure correct earth ground and polarization. After servicing, reconnect power using power switch.

### Ice Maker

The unit uses an ice maker that consists of a mold heater, thermostat, motor, and wire harness. The ice maker always starts from and stops at the “park” position. In the park position (the ejector blades are pointing horizontally towards the back of the ice maker). Just before reaching the park, position the mold is filled with water. At the park position all electrical components are de-energized, even though the shut-off arm is down, and the ice maker is ready for the next freeze cycle. The ice maker takes from 30 minutes to one hour to freeze the water. The primary time factors are the temperature in the freezer and the amount of airflow around the ice maker. Colder freezer settings and free air space around the ice maker to let air circulate will help make ice faster. After the ice forms, the ice maker continues to wait until it reaches 15°F before it starts the harvest cycle. This ensures that the ice is solid in all the cavities. At 15°F the thermostat closes, the mold heater turns on, and the ejector blades rotate up and forward until they stall out against the ice. The motor is designed to stall out and is geared to generate a lot of pressure. This minimizes the amount of melting needed to extract the ice. As soon as the ice is loose enough to move, the ejector pushes the ice out of the mold during the second half of the first revolution. During the second revolution, the ejector pushes the ice into the bucket.

Just before the ejector completes the second revolution, the ice maker turns the water valve on for approximately 7 seconds and refills the mold with approximately 4 ounces of water and the freezing cycle is ready to begin again.

To access the ice maker, open the freezer door, remove ice bucket assembly, remove screws securing ice maker, disconnect wire harness, repair/replace ice maker.

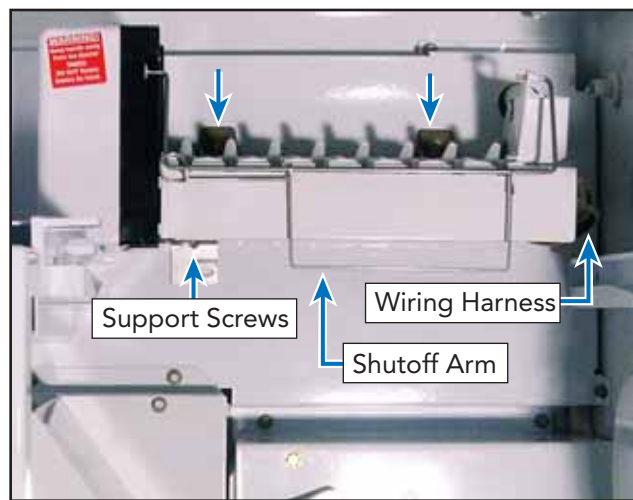

To access module and heater assembly, remove three screws on front of module and remove support assembly.

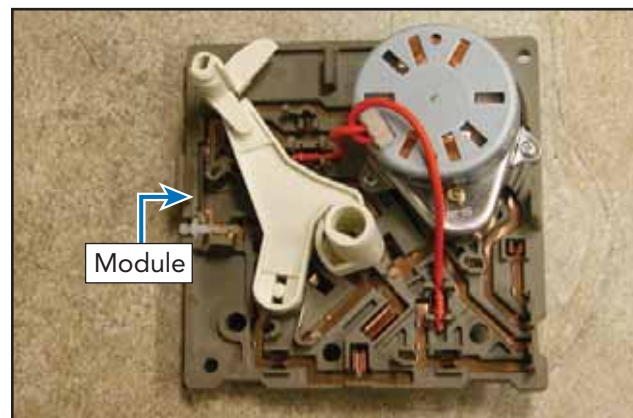

## ⚠ WARNING

To avoid risk of electrical shock, personal injury, or death, disconnect electrical power to unit using power switch before servicing. Wires removed during disassembly must be replaced on proper terminals to insure correct earth ground and polarization. After servicing, reconnect power using power switch.

### Ice Maker (continued)

To make ice, an ice maker needs power, water, and sub-freezing temperatures.

**Note:** The freezer door switch turns off power to the ice maker when the freezer door is open. It will be necessary to manually close the freezer door switch for some troubleshooting steps. Ensure that the shut-off arm is down and instruct customer on its use if necessary.

To ensure power to the ice maker without a meter, remove the module cover and take note of the test points.

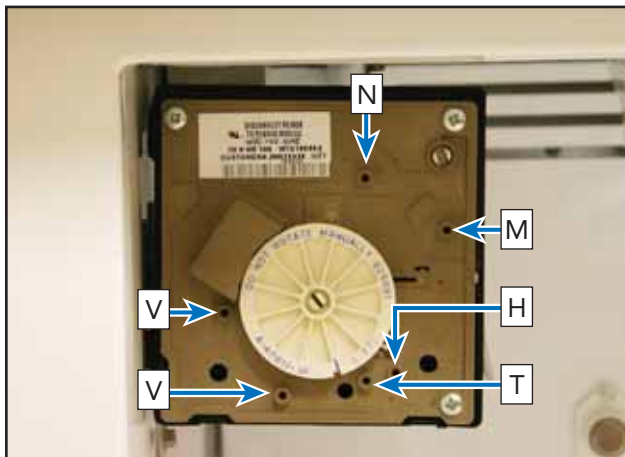

Test Point	Component
N	Neutral side of line
M	Motor connection
H	Heater connection
T	Thermostat connection
L	L1 side of line
V	Water valve connection

Place a 14 gauge jumper wire across test points T and H. With hands clear of the ice maker, manually close the freezer door switch. This will put the ice maker in a manual cycle. If the ejector does not rotate, this indicates no power to the ice maker. Trace power from the wall socket to the door switch and to the connector. Repair circuit and connections or replace door switch as needed. If the ejector begins to rotate (very slowly) there is power. With power present, verify 0 VAC between test points T and H (this verifies the thermostat has closed). Verify heater resistance is approximately 264 Ω. With motor running, verify heater is heating. If no heat is detected, replace mold assembly. Next ensure water is supplied to the ice maker. When the ejector blade gets to the 11:00 position, the water valve is energized for 7.5 seconds.

Verify the water valve has 120 VAC between test points V and N and approximately 4.75 ounces of water is dispensed. If voltage is present and water is not dispensed verify water supply and fill rate. **CAUTION: DO NOT** use a Reverse Osmosis Water Filtration System. It reduces the water pressure below 20 psi and the ice maker will not fill. Use of a Reverse Osmosis system will void the warranty. Poor water quality can cause ice maker to fail or produce unacceptable cubes. Install a water filter to eliminate bad taste, odor, and visible contaminants. Mineral content or sand can restrict screen in water fill valve or particles of sand can keep valve from seating properly.

If water valve does not operate properly, the following could occur: no ice production, small or hollow ice cubes, flooding of ice container. Mineral content can cause lime build up in the mold, wicking of water over the mold and poor

## ⚠ WARNING

To avoid risk of electrical shock, personal injury, or death, disconnect electrical power to unit using power switch before servicing. Wires removed during disassembly must be replaced on proper terminals to insure correct earth ground and polarization. After servicing, reconnect power using power switch.

### Ice Maker (continued)

cube release. Mineral content can also restrict saddle valves. Verify water supply line is "ON", water pressure is not below 20 psi, saddle valve is fully open clear restrictions by fully closing and opening valve to dislodge sediment (if necessary, remove valve and enlarge pierced hole to 3/16" diameter with a drill and reinstall saddle valve) ensure water line to unit is not pinched/kinked/clogged, ice is not present in inlet tube blocking water flow, water pressure is not above 120 psi. Water fill can be increased by turning the adjustment screw counterclockwise and decreased by turning the screw clockwise. One half turn will adjust the fill by approximately two thirds of an ounce. If supply is OK replace water valve. If no voltage is present, verify harness. If OK, replace module.

### Thermal Cut Out (TCO)

The TCO is a safety device and must NOT be bypassed. If the TCO is found to be electrically open, this indicates an overheat in the ice maker and the ice maker must be replaced.

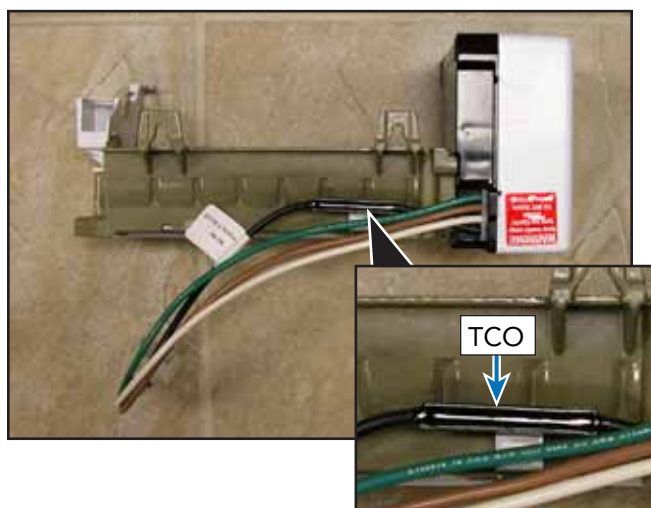

### Component Testing–Ice maker

Module Ohmmeter Checks with No Power to Ice maker and Ejector Blades in End of Cycle			
Test Points	Component	Module Position	Ohms
L-H	Mold & Heater	Attached to Support	264
L-M	Motor	Separate from Heater	16,100

Module Voltage Checks with Motor or Test Light Power to Ice maker			
Test Points	Component	Line Voltage	0 Volts
T-Module	Power On	Power Off	Power Off
T-H	Bimetal	Open	Closed
L-H	Heater	On	Off
L-M	Motor	On	Off
N-V	Water Valve	On	Off

## ⚠ WARNING

To avoid risk of electrical shock, personal injury, or death, disconnect electrical power to unit using power switch before servicing. Wires removed during disassembly must be replaced on proper terminals to insure correct earth ground and polarization. After servicing, reconnect power using power switch.

### Auger Motor (Dispenser models)

The unit uses a two directional auger motor to provide crushed and cubed ice. When the end user desires crushed ice, the auger motor drives the auger in the counterclockwise direction to produce crushed ice. When the end user desires cubed ice the auger motor drives the auger in the clockwise direction to produce cubed ice.

To access the auger motor:

1. Remove ice bucket.
2. Remove screws securing auger cover and remove panel.

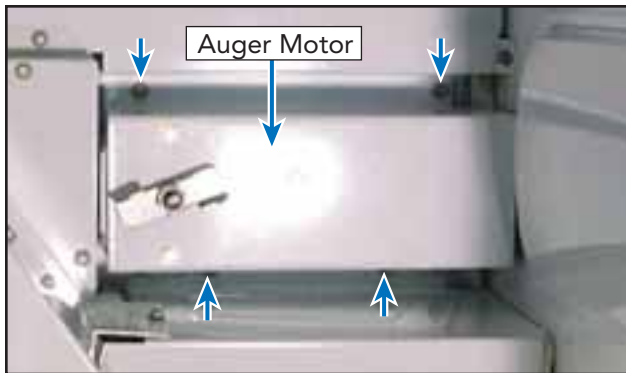

3. Remove right side light lens (see interior lights page 53).

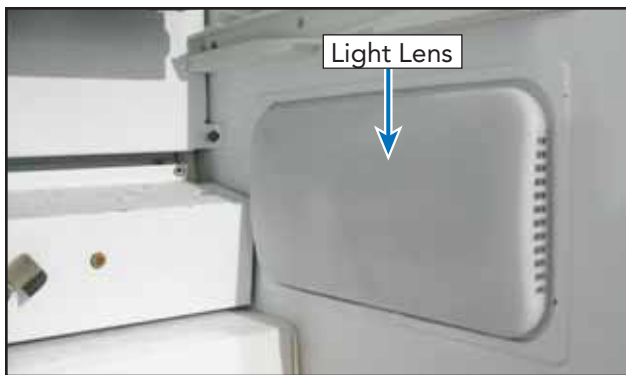

4. Remove 5/16" screws securing auger motor and 9/16" nut securing auger drive.

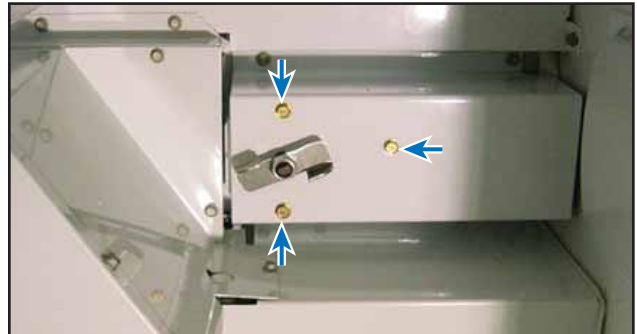

6. Remove auger motor, disconnect wiring, repair/replace auger motor.

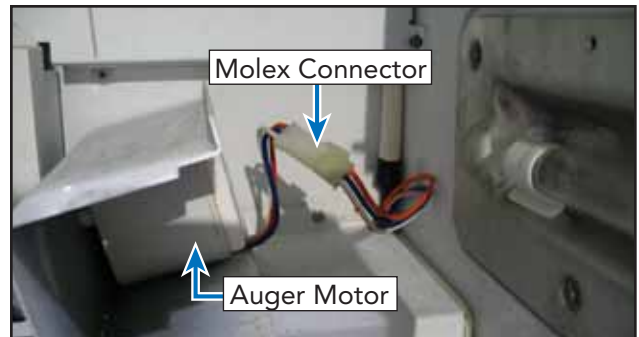

7. Reverse procedure to reinstall.

The motor has three wires; white (common), orange, and blue. The motor is protected by a diode and polarity is important. See the chart below for expected readings.

Test Point	Meter Lead Position	Reading
White-Blue	Black lead on White and Red lead on Blue	13.55M $\Omega$
White-Blue	Red lead on White and Black lead on Blue	Infinite Ohms
White-Orange	Black lead on White and Red lead on Orange	Infinite Ohms
White-Orange	Red lead on White and Black lead on Orange	8.49 M $\Omega$

**⚠ WARNING**

To avoid risk of electrical shock, personal injury, or death, disconnect electrical power to unit using power switch before servicing. Wires removed during disassembly must be replaced on proper terminals to insure correct earth ground and polarization. After servicing, reconnect power using power switch.

**Freezer Evaporator Fan–Dispenser Models**

The unit uses a fan motor to pull air over the evaporator coil and circulate it through the unit.

1. Remove ice bucket.
2. Remove screws securing evaporator fan cover and remove panels.

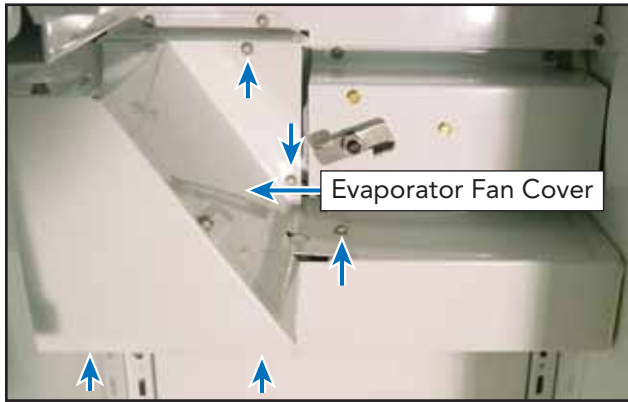

3. Remove screws and fan bracket.

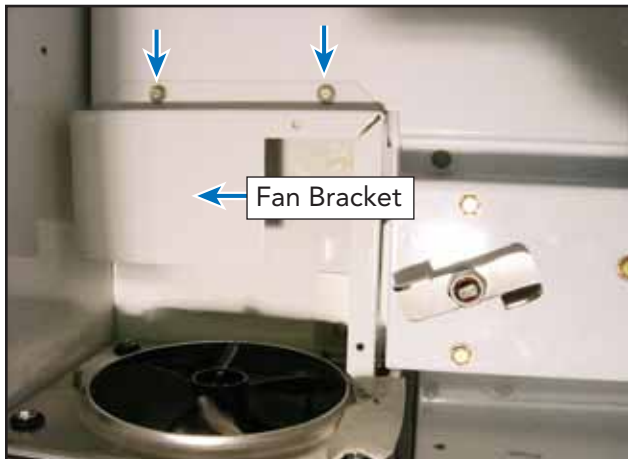

4. Remove screws and evaporator motor cover.

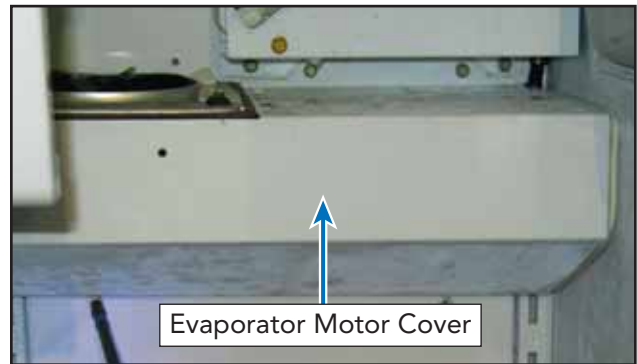

5. Disconnect wiring, and repair/replace freezer fan.



6. Reverse procedure to reinstall.



## ⚠ WARNING

To avoid risk of electrical shock, personal injury, or death, disconnect electrical power to unit using power switch before servicing. Wires removed during disassembly must be replaced on proper terminals to insure correct earth ground and polarization. After servicing, reconnect power using power switch.

### Freezer Evaporator Fan–Non Dispenser Models

1. Remove lower freezer baskets.
2. Remove screws securing left and right freezer glides and remove glides.



3. Remove right side light lens (see interior lights page 53).

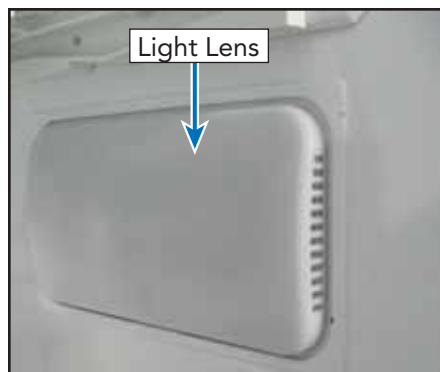

4. Remove screws and center evaporator cover.



4. Disconnect wiring, and repair/replace freezer fan.

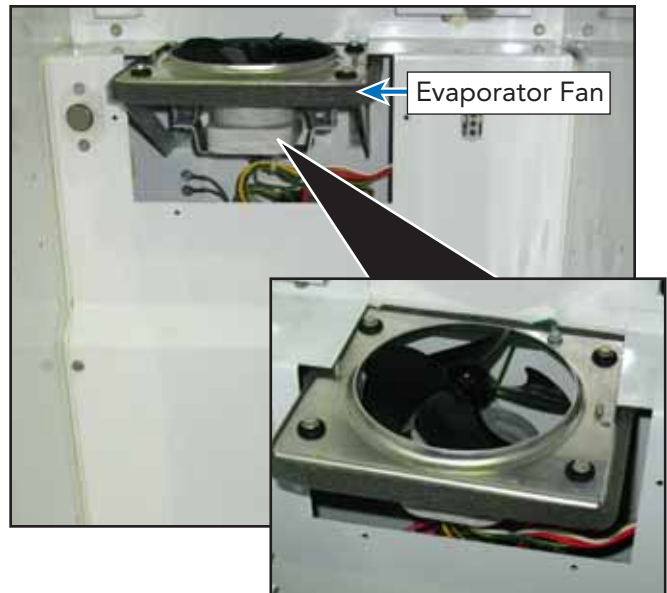

5. Reverse procedure to reinstall.

## ⚠ WARNING

To avoid risk of electrical shock, personal injury, or death, disconnect electrical power to unit using power switch before servicing. Wires removed during disassembly must be replaced on proper terminals to insure correct earth ground and polarization. After servicing, reconnect power using power switch.

### Freezer Thermistor

The freezer uses the same thermistor as does the fresh food section however, the freezer thermistor controls the cycle of the compressor. As the temperature in the compartment changes, the resistance in this device changes. These changes are measured by the low voltage board, and controls the operation of the compressor, condenser, and freezer evaporator fan. *Refer to the thermistor chart on page 38.*

To access the freezer thermistor:

1. Remove drawers and shelves.
2. Remove screws securing the thermistor.



3. Pull thermistor into freezer cabinet, disconnect wiring, repair/replace thermistor.

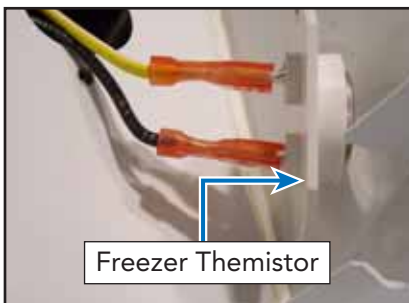

4. Reverse procedure to reinstall.

© 2009 Viking Preferred Service

### Defrost Heater

The unit use a heater to help remove ice build up during the defrost cycle. When the defrost terminator closes, voltage is supplied to the heater via the control board. With the main power switch OFF, the defrost Heater can be tested by removing the orange wire off of terminal E6 on the HV board. Using an ohm meter, check the brown wire and Neutral and you should read approximately 30  $\Omega$ . During the defrost cycle Line voltage passes through the Defrost Terminator the into terminal E5 (orange wire). With the defrost heater relay activated, the voltage exits the HV board from Terminal E6 (orange) to the heating element. If voltage is present at E5 but not at E6, then the Defrost relay is open. If there is 0 volts At E5, then the terminator is open.

Another method to test can be achieved by testing at the 15-wire Molex plug on the right side of the Control Housing. Refer to page 82 pin locations.

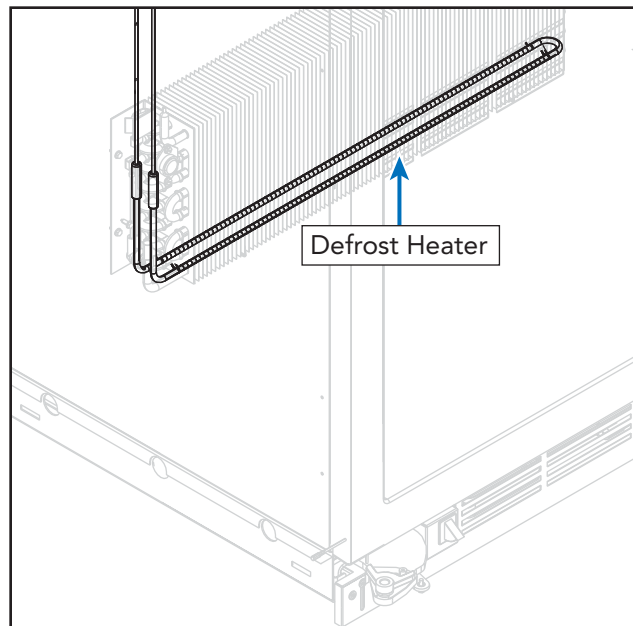

## ⚠ WARNING

To avoid risk of electrical shock, personal injury, or death, disconnect electrical power to unit using power switch before servicing. Wires removed during disassembly must be replaced on proper terminals to insure correct earth ground and polarization. After servicing, reconnect power using power switch.

### Defrost Heater–Dispenser Model

1. Remove drawers.
2. Remove screws, shelf brackets and glides.
4. Remove clips securing defrost heater, disconnect wiring, and repair/replace defrost heater.

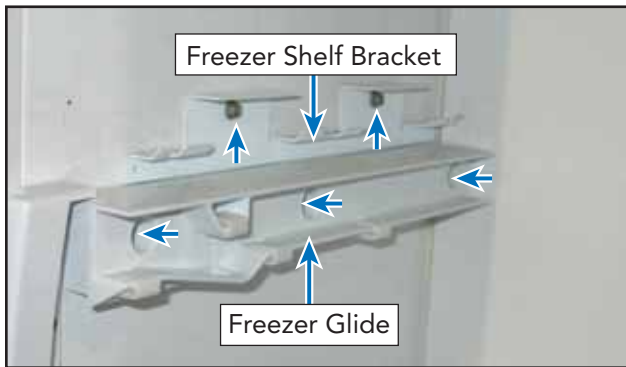

3. Remove screws securing evaporator cover and remove.

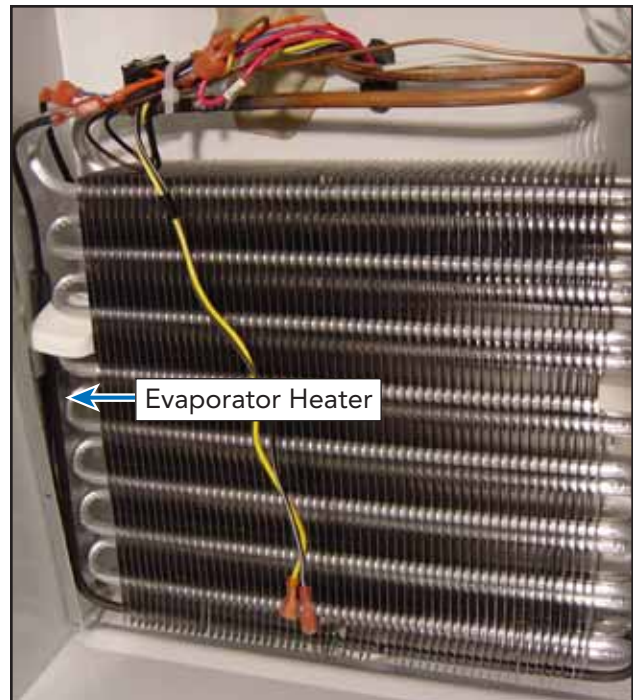
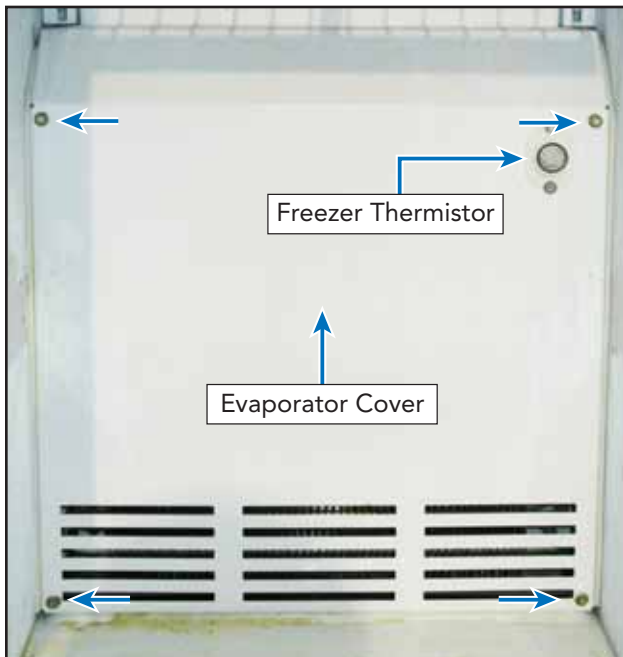



**⚠ WARNING**

To avoid risk of electrical shock, personal injury, or death, disconnect electrical power to unit using power switch before servicing. Wires removed during disassembly must be replaced on proper terminals to insure correct earth ground and polarization. After servicing, reconnect power using power switch.

### Defrost Heater–Non Dispenser Model

1. Follow steps 1-4 under evaporator fan non-dispenser model.
2. Remove screws securing rear panel and remove rear panel.

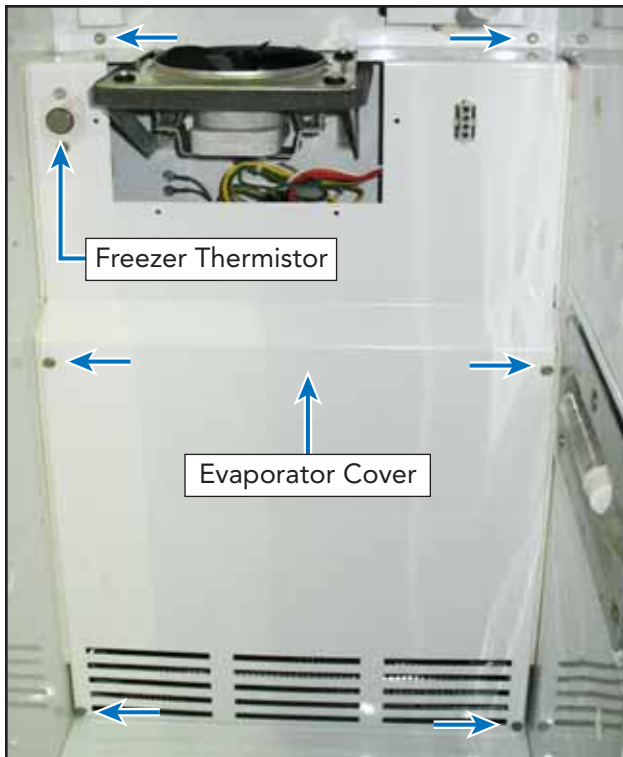

3. Remove clips securing defrost heater, disconnect wiring, and repair/replace defrost heater (see step 4 dispenser model).
4. Reverse procedure to reinstall.

### Defrost Terminator

The defrost terminator is a bimetal switch that is normally open. Below 20+/-8.5 °F, the terminator is closed. In order to test, first switch the main power switch to "Off". Locate the brown wire on E5 of the HV board. Unplug the wire and check for continuity between the brown wire and the black wire at E10. If "0" is read then the bimetal is closed. If infinity (∞) is read, the bimetal is open.

**Note:** Freezer temp must be below 20+/-8.5 °F in order to check for a defective bimetal.

Another method to test can be achieved by testing at the 15-wire Molex plug on the right side of the Control Housing. Refer to page 82 pin locations.

To access the defrost terminator:

1. Follow steps 1-4 under Defrost Heater disassembly.
2. Unclip the terminator, disconnect wiring, repair/replace terminator.

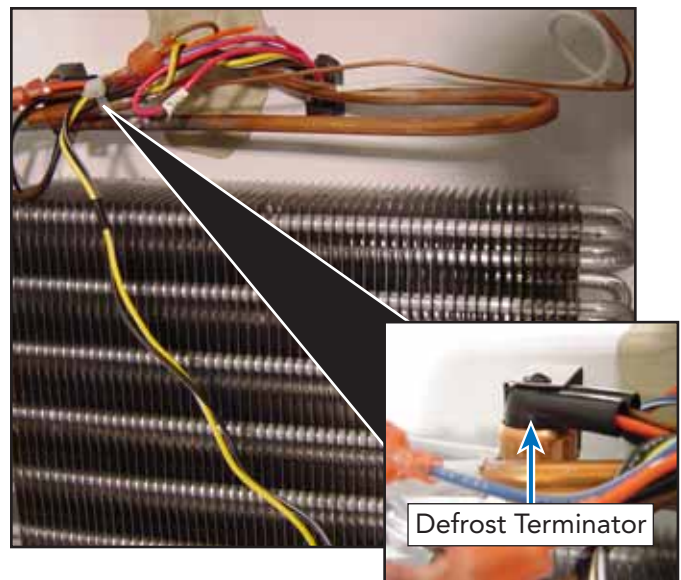

3. Reverse procedure to reinstall.

**⚠ WARNING**

To avoid risk of electrical shock, personal injury, or death, disconnect electrical power to unit using power switch before servicing. Wires removed during disassembly must be replaced on proper terminals to insure correct earth ground and polarization. After servicing, reconnect power using power switch.

**Float Switch**

The unit uses a float switch in conjunction with the drain pan heater to vaporize condensate created from the refrigerator cooling process. The switch is normally open and closes as the water level in the pan rises thus energizing the drain pan heater. When the water is vaporized the switch opens removing power from the drain pan heater.

To access the float switch, remove the lower access panel and the float switch is now accessible. Verify the switch reads infinite resistance when in the down position and 0 Ω in the up position. If the switch does not open or close properly, replace the float switch.

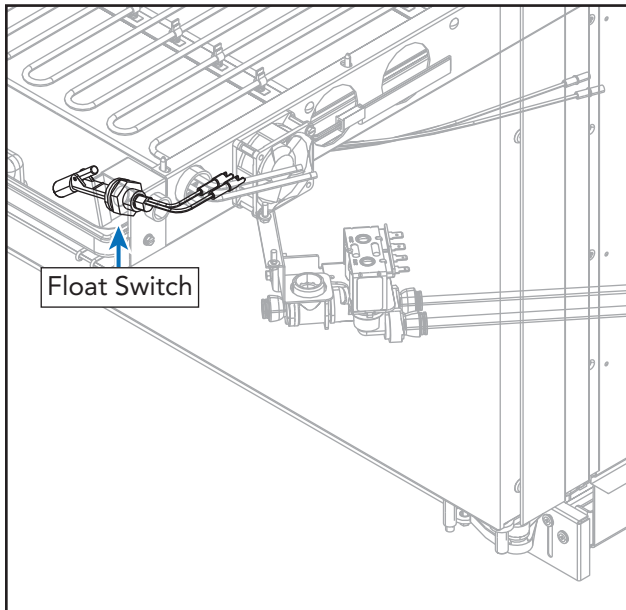

**Water Valve–Non-Dispenser Model**

The Non-Dispenser Side-by-Side models utilize a single coil water valve to fill the ice maker when required.

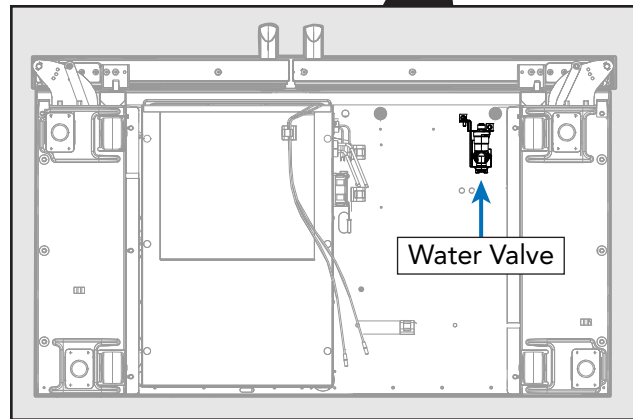
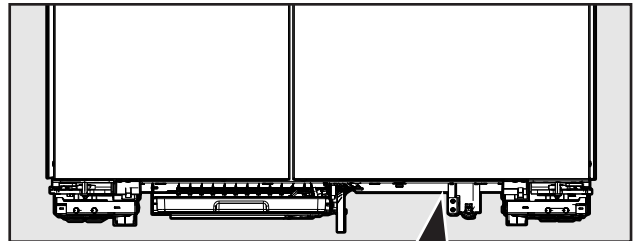

Bottom View

**Dual Water Valve System–Dispenser Model**

On the Dispenser models, a dual water valve system is utilized. When the water dispenser is activated, 120 VAC is sent to both the primary and secondary coils shown on page 67. The primary coil (water) opens and allows water to flow through the water filtration system then back into the secondary valve and then out (water) to the door dispenser.

When the ice maker calls for a fill cycle, then same procedure occurs except water is sent to the filter, into the secondary valve and then out (ice) to

**⚠ WARNING**

To avoid risk of electrical shock, personal injury, or death, disconnect electrical power to unit using power switch before servicing. Wires removed during disassembly must be replaced on proper terminals to insure correct earth ground and polarization. After servicing, reconnect power using power switch.

**Dual Water Valve System–Dispenser Model (continued)**

the ice maker. The purpose of the dual valve is so that if one valve mechanically sticks open, the other would inhibit a flood condition

To access the water valves, remove the lower access panel to expose the fill valves. To check the valves, use an Ohm meter and verify coil resistance is approximately 192.2 Ω.

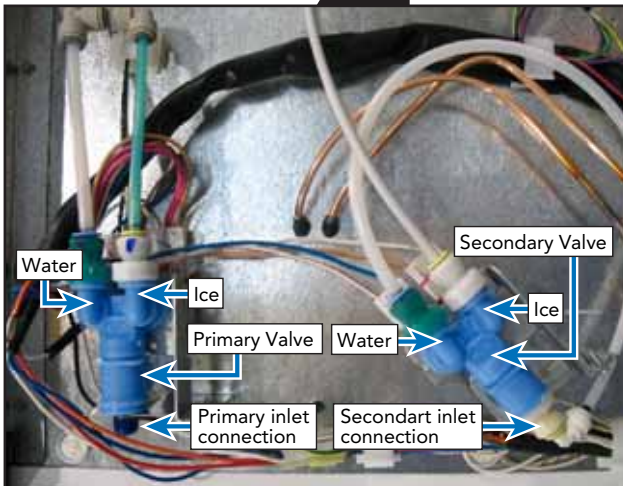
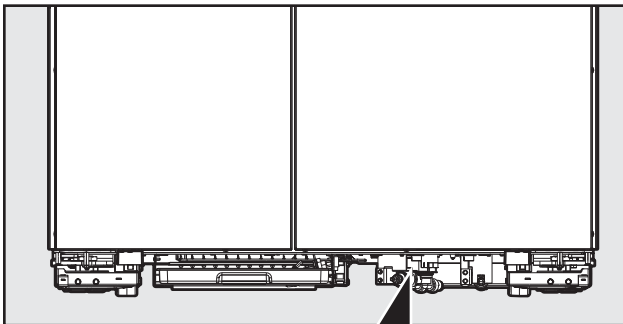

**Bottom View**

**Drain Pan Heater**

The unit uses a drain pan heater to evaporate condensate created by the refrigerator cooling process. The pan heater is energized once the float switch closes supplying 120 VAC.



To access the drain pan heater, remove the lower access panel, slide the drain pan heater assembly out and the heater is accessible. Verify the resistance is approximately 500 Ω. Verify 120 VAC to the heater and that the float switch is closed. If the switch is closed and no voltage is supplied, verify wiring, power disconnect switch has not been turned "On", and supply voltage. If voltage is supplied, the float switch is closed, and the heater does not energize, replace the heater.

Parts Location-Dispenser

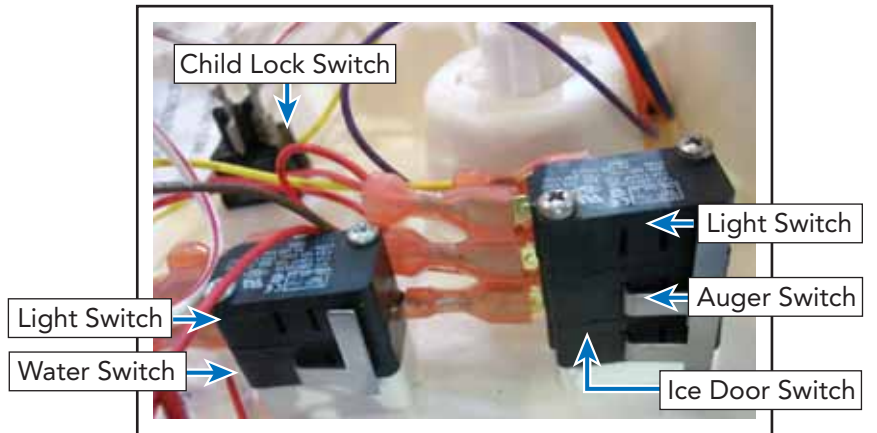
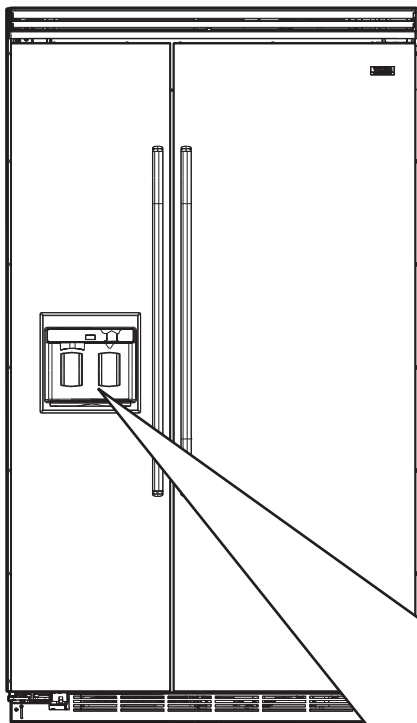

Back view of switches looking forward

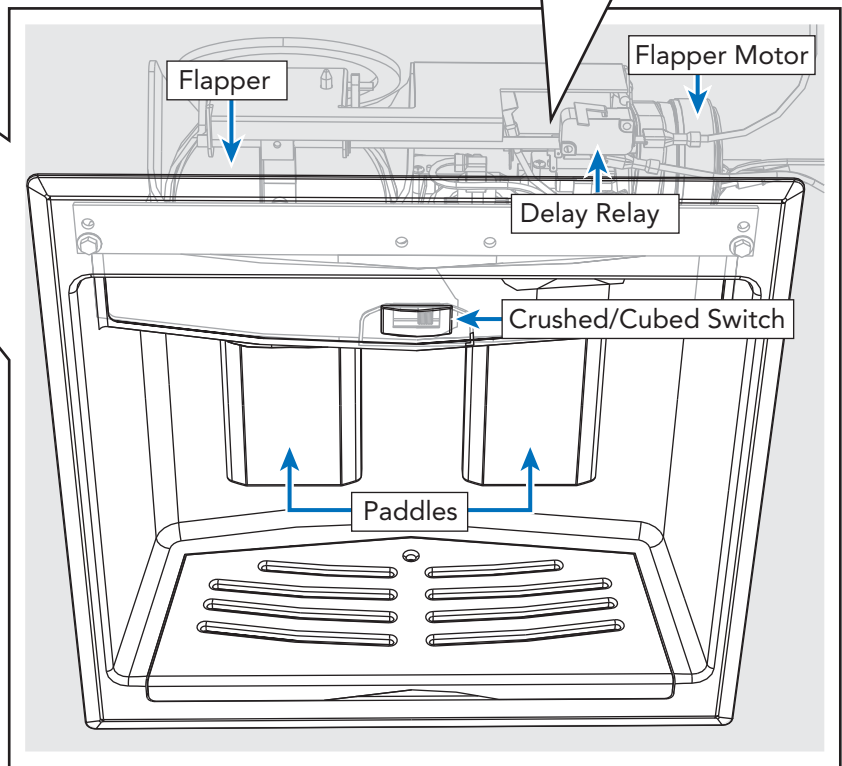

## ⚠ WARNING

To avoid risk of electrical shock, personal injury, or death, disconnect electrical power to unit using power switch before servicing. Wires removed during disassembly must be replaced on proper terminals to insure correct earth ground and polarization. After servicing, reconnect power using power switch.

### Dispenser Assembly

The unit uses a dispenser assembly consisting of a crushed/cubed switch, motorized flapper, ice chute, paddles in conjunction with a micro switch to deliver ice and water to the end consumer.

To access dispenser:

#### Dispenser Bezel

1. Remove grill plate.

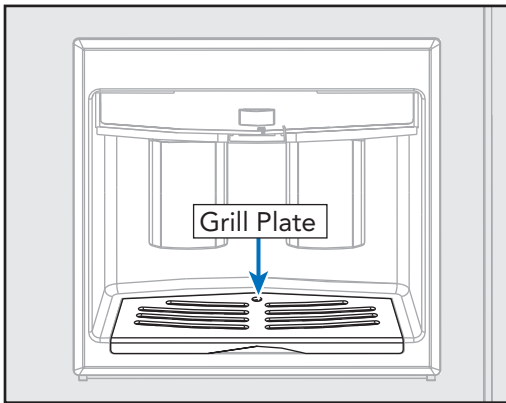

2. Remove screws at bottom securing the dispenser bezel.

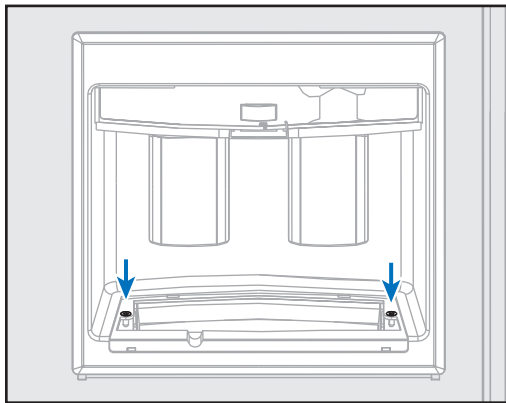

3. Remove screws at top securing the dispenser bezel, screws securing the chute cover, gently pull the crushed/cubed switch cover off, and remove dispenser bezel.

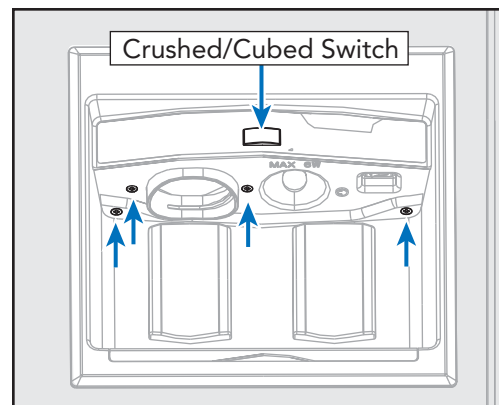

4. The covers for the ice and water paddles are attached to the rear of the dispenser bezel. Remove the screws to replace the cover.
5. Reverse procedure to reinstall.

**⚠ WARNING**

To avoid risk of electrical shock, personal injury, or death, disconnect electrical power to unit using power switch before servicing. Wires removed during disassembly must be replaced on proper terminals to insure correct earth ground and polarization. After servicing, reconnect power using power switch.

**Cubed/Crushed Switch**

1. Remove dispenser bezel (*follow dispenser bezel procedure*).
2. Remove screws securing switch, remove switch, disconnect wiring, repair/replace switch.

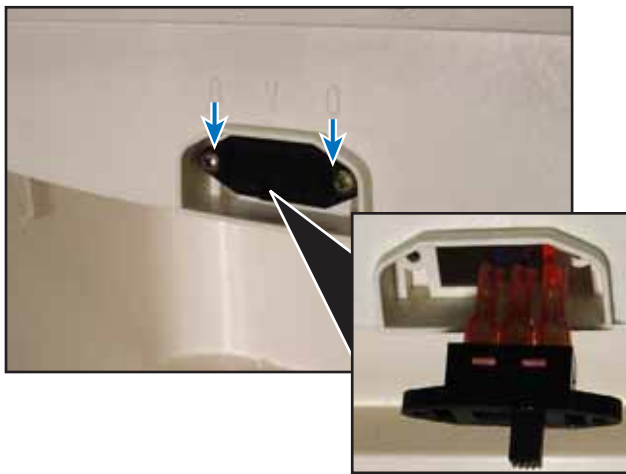

3. Reverse procedure to reinstall.

To test switch, review the chart below.

Test Point	Switch Position	Reading
Orange–Purple	Crushed	0 Ω
Orange–Purple	Cubed	Infinite Ohms
Blue–Purple	Crushed	Infinite Ohms
Blue–Purple	Cubed	0 Ω

**Ice and Water Paddles**

1. Remove escutcheon (*follow bezel disassembly procedure*).
2. Remove screws securing ice dispenser paddle (left) and water dispenser paddle (right).



3. Slide paddle out of upper dispenser to remove.
4. Reverse procedure to reinstall.



## ⚠ WARNING

To avoid risk of electrical shock, personal injury, or death, disconnect electrical power to unit using power switch before servicing. Wires removed during disassembly must be replaced on proper terminals to insure correct earth ground and polarization. After servicing, reconnect power using power switch.

### Cavity Cover Assembly

1. Remove screws securing upper dispenser.



2. Disconnect wiring harness and remove cavity cover.

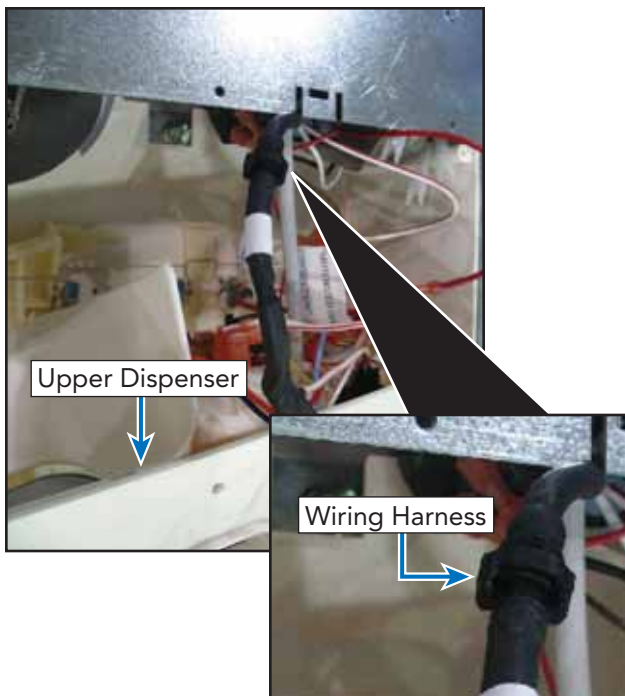

3. Replace switch assembly if necessary.

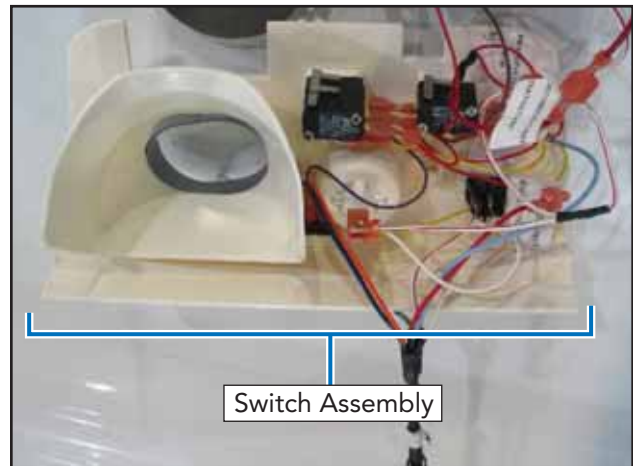

4. Reverse procedure to reinstall.

## ⚠ WARNING

To avoid risk of electrical shock, personal injury, or death, disconnect electrical power to unit using power switch before servicing. Wires removed during disassembly must be replaced on proper terminals to insure correct earth ground and polarization. After servicing, reconnect power using power switch.

### Ice Dispenser Module Assembly

When the ice dispenser Ice Door switch is activated, 120 volts is sent to the relay coil and the Ice Door motor is energized. After the switch is deactivated, the holding relay will keep the Ice Door open for an additional 8 seconds to allow any remaining ice cubes in the chute to dispense.



1. Remove cavity cover (*follow cavity cover disassembly procedure*).
2. Remove screws to remove Ice Module Assembly.



3. Replace ice dispenser assembly if necessary.



4. Reverse procedure to reinstall.



## ⚠ WARNING

To avoid risk of electrical shock, personal injury, or death, disconnect electrical power to unit using power switch before servicing. Wires removed during disassembly must be replaced on proper terminals to insure correct earth ground and polarization. After servicing, reconnect power using power switch.

### Ice Door Switch

1. Remove cavity cover (*follow cavity cover disassembly procedure*).
2. Test switch. Switch should read 0  $\Omega$  with switch depressed and infinite  $\Omega$  with switch at rest. Measure Yellow – Double Red, Purple – Double Red, and Red to Brown.

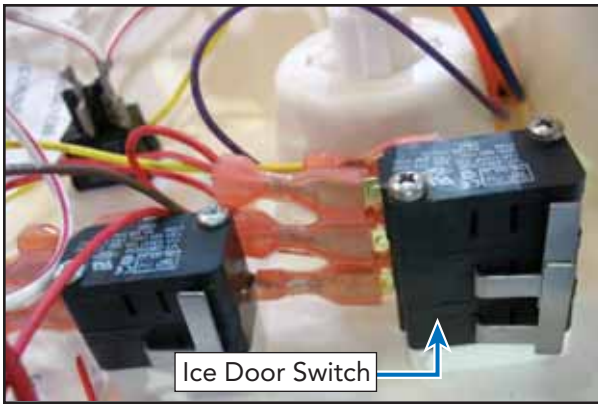

3. If switch is found to be defective, replace entire cavity cover assembly (see page 71).

### Water Switch

1. Remove cavity cover (*follow cavity cover disassembly procedure*).
2. Test Switch. Switch should read 0  $\Omega$  from Red – Yellow with the switch depressed and infinite  $\Omega$  with switch at rest. Switch should read 0  $\Omega$  from Red – Gray with the switch depressed and infinite  $\Omega$  with switch at rest.

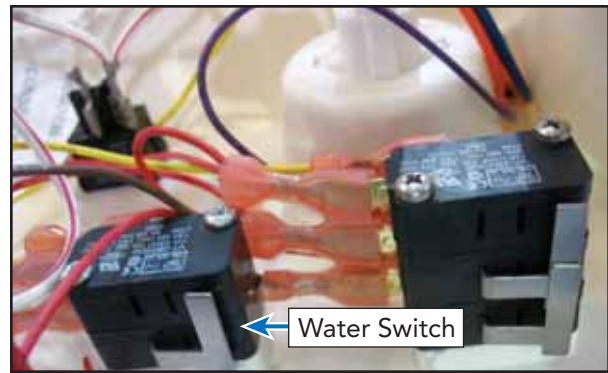

3. If switch is found to be defective, replace entire cavity cover assembly (see page 71).

## ⚠ WARNING

To avoid risk of electrical shock, personal injury, or death, disconnect electrical power to unit using power switch before servicing. Wires removed during disassembly must be replaced on proper terminals to insure correct earth ground and polarization. After servicing, reconnect power using power switch.

### Child Lock Switch

1. Remove cavity cover (*follow cavity cover disassembly procedure*).
2. Test switch. Lock switch should read 0  $\Omega$  when the switch is in the “-” position and should read infinite  $\Omega$  in the “O” position.

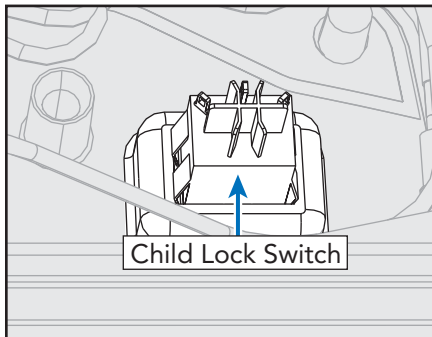

3. If switch is found to be defective, replace entire cavity cover assembly (see page 71).

### Dispenser Light Socket

1. Remove cavity cover (*follow cavity cover disassembly procedure*).
2. Test switch.

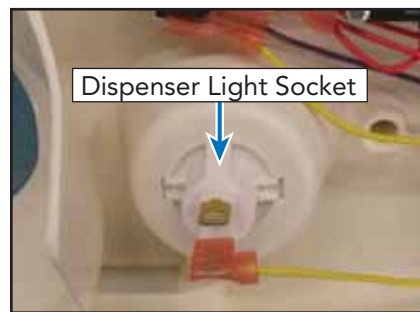

3. If switch is found to be defective, replace entire cavity cover assembly (see page 71).

## Dispenser Heater

The dispenser has a heater foamed into the door to be used in case of moisture/sweating in the dispenser assembly. The heater does not leave the factory hooked up and can be connected if needed.

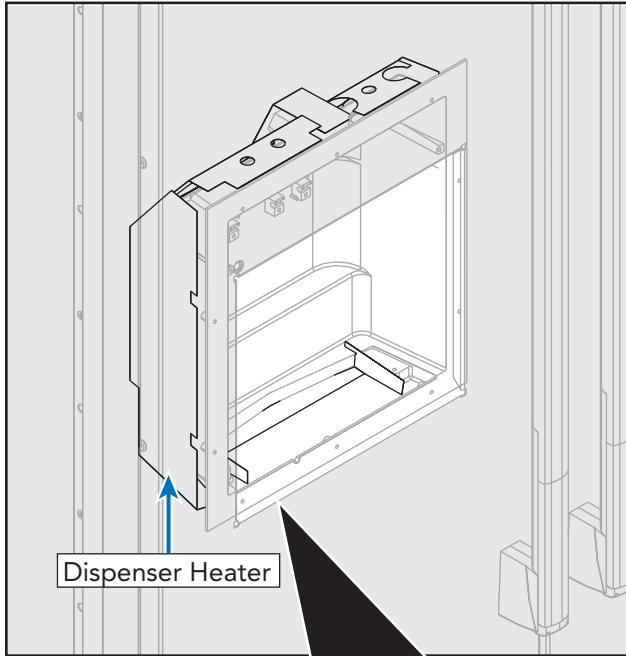

To connect the dispenser heater:

1. Remove escutcheon (*follow bezel dispenser disassembly procedure*).
2. Remove upper dispenser (*refer to upper dispenser disassembly procedure*).
3. Locate wires with female ends for the heater in the upper right hand corner.

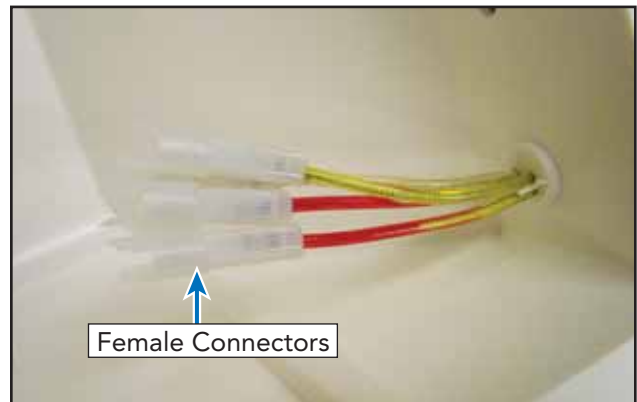

4. Locate wires with male ends.

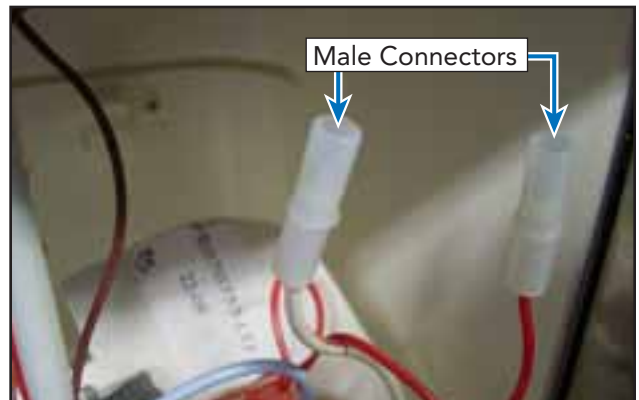

5. Connect Red to Orange and White to Orange or Red to Yellow and White to Yellow.

The dispenser heater has two heater loops and should one open the alternate loop could be connected. The heater measure 6800  $\Omega$  Orange – Orange and Yellow – Yellow.

6. Reverse procedure to reinstall.

## Troubleshooting Guide

Below and on the following page are some general guides should a problem be detected. Please refer to the test procedures in this manual to determine the defective component.

Problem	Probable Cause	Correction
Unit will not operate	Power supply Circuit breaker Power switch	Verify voltage Reset breaker Turn to the "ON" position
Water overflows defrost pan	Unit not level Float switch Pan heater	Ensure unit is level Verify operation of float Verify heater is working
Ice maker will not operate	Freezer too warm Shut off arm Water valve Water supply	Verify freezer temperature Verify the arm is in the "ON" position Verify valve operation Verify water supply
Refrigerator too warm	Door opening Warm food placed in unit Control setting Door seal Airflow Refrigerator fan	Minimize door openings Allow temperatures to stabilize Move control to medium setting Verify closure, replace if needed Ensure airflow is not obstructed Verify movement/operation of fan
Refrigerator too cold	Temperature setting Control board Airflow	Move control to medium setting Verify proper operation Verify airflow is proper
Freezer too warm	Control setting Door seal Dirty condenser Control board	Move control to medium setting Verify closure, replace if needed Clean condenser coil Verify operation
Freezer too cold	Temperature setting Defrost thermostat Control board	Move to medium setting Verify thermostat is closing Verify operation
Unit runs continually	Control setting Door seal Dirty condenser Condenser/evaporator fan Control board Freezer thermistor	Move to medium setting Verify closure, replace if needed Clean condenser coil Verify movement/operation of fan Verify operation Verify thermistor is not shorted
Frost on evaporator	Defrost thermostat Evaporator fan Defrost heater	Verify thermostat is closing Check connection and possible short open condition
Unit running and no lights	Sabbath Mode Open circuit	Verify operation of Sabbath Mode Repair/replace wiring

<b>Ice Problems</b>	<b>Action</b>
Jammed cubes (small or oversized cubes)	Adjust fill level or level ice maker or refrigerator
Hollow cubes	Adjust low fill or remove restrictions in supply line Level ice maker or refrigerator Remove obstructions to air flow at fill end so it freezes before thermostat end
Ice build-up on ejector blades	Usually caused by hollow cubes See hollow cubes above Remove ice maker, thaw out
Cubes falling back into mold during ejection	If some cubes are small, check fill level Check if fill cup is displaced and blocking ice Fix fill cup or replace ice maker
Cubes falling over back of ice maker	Check if fill cup is displaced and blocking ice Fix fill cup or replace ice maker
<b>Power Problems</b>	<b>Action</b>
No power to ice maker at connector socket	Determine discontinuity by tracing power
No power to water valve	Determine discontinuity by tracing power
<b>Water Problems</b>	<b>Action</b>
No water to refrigerator	Turn on supply Look for obstructions in supply line or valve
No water to ice maker	Look for obstructions in water valve or fill tube
Clogged water valve	Clean or replace water valve depending on type
Insufficient water to ice maker (with correct fill time)	Check for restrictions in supply line and valve, especially saddle valves
Low water pressure at supply	Increase water pressure to 20 – 120 PSI
Low water pressure at water valve	Look for restrictions in line
Excessive water pressure	Install pressure regulator and set to 60 PSI
Low water fill volume	Adjust water fill screw, clear obstructions in supply line or supply valve, or replace water valve
Excessive water fill volume	Adjust water fill screw, reduce water pressure, or replace water valve
Water overflows fill cup	Reposition fill-tube in fill cup or remove obstruction in fill cup
Water overflows mold	Adjust water fill screw, level ice maker or refrigerator, reduce water pressure, or replace water valve or ice maker
Leaky water valve	Tighten connections or replace water valve
<b>Temperature Problems</b>	<b>Action</b>
Freezer too warm	Adjust freezer setting or repair refrigerator

Ice maker Problems	Action
Raised shut-off arm	Lower shut-off arm to "ON" position
Broken or bent shut-off arm	Repair arm or replace ice maker
Shut-off arm stuck or obstructed	Remove obstruction
Ice maker not level	Check level of refrigerator first, then level ice maker
Can't level ice maker	Level refrigerator first, then try again
Open thermostat (won't close below 17°F)	Replace thermostat
Closed thermostat (won't open above 32°F)	Replace thermostat
Thermostat out of calibration	Replace thermostat
Heater not staked in mold	Replace ice maker
Won't cycle test with power available	Replace ice maker
Won't eject ice with power available	Replace ice maker

## Schematic-Non Dispenser Model

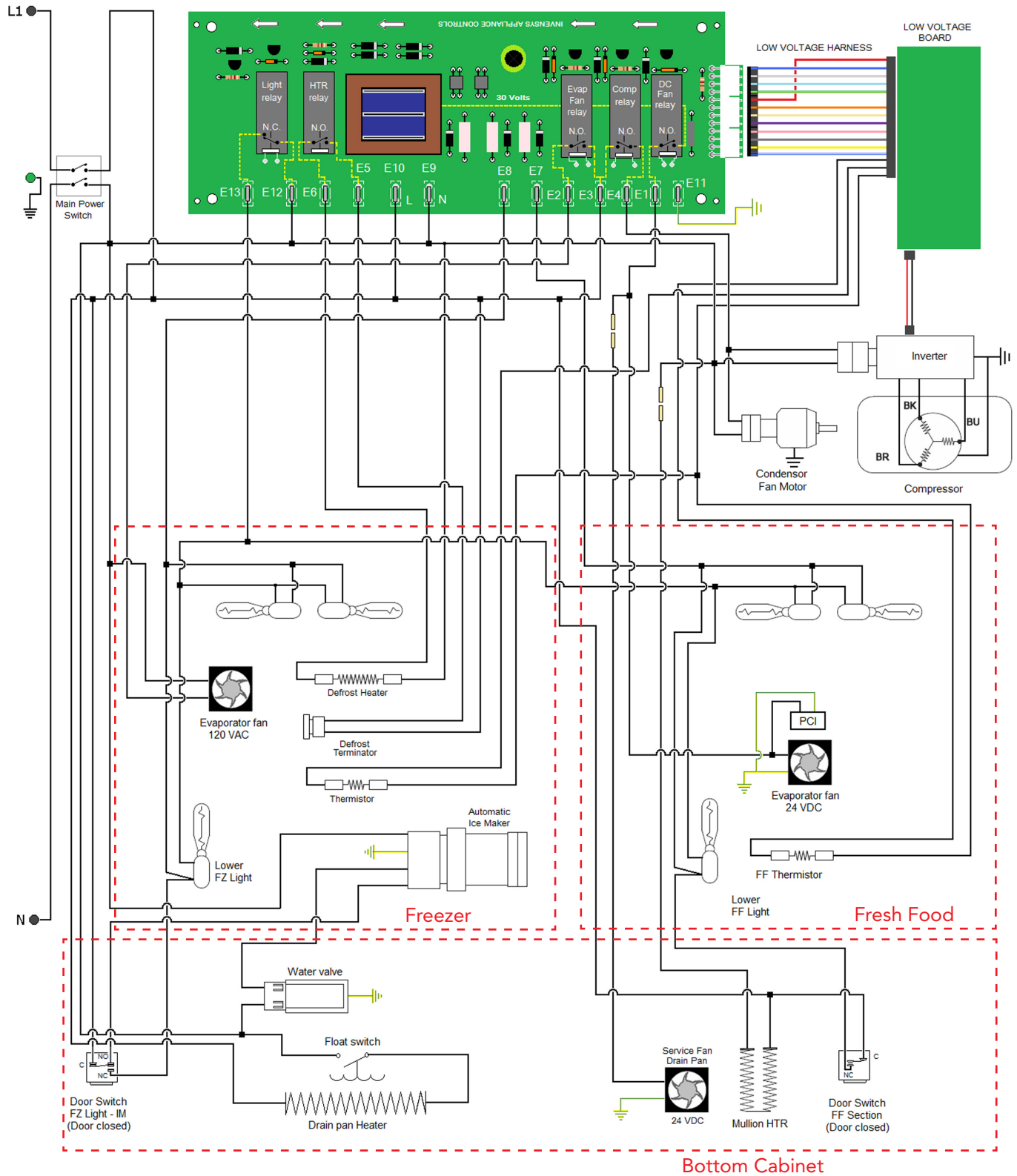

## Schematic-Dispenser Model

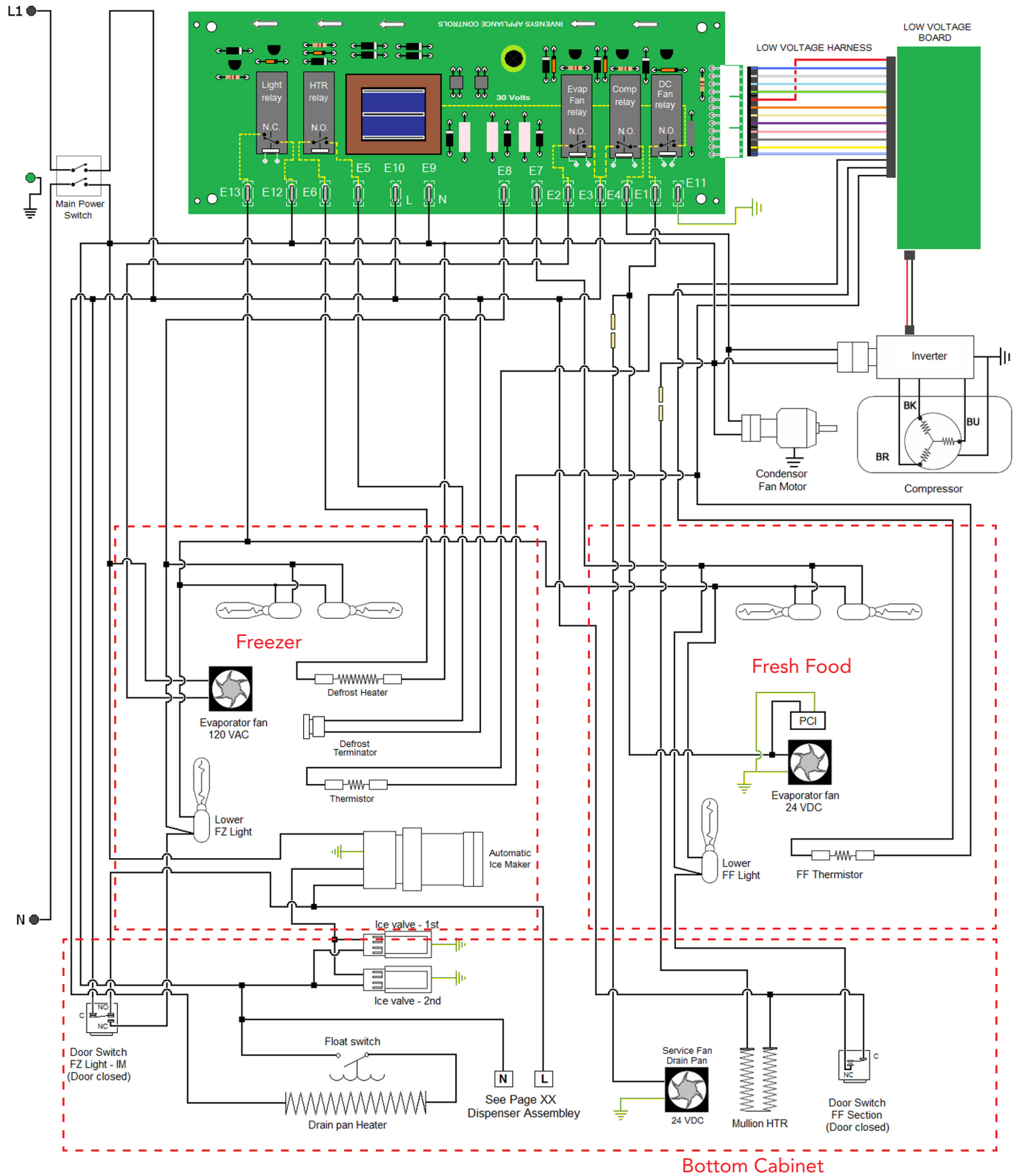



## Schematic–Ice and Water Dispenser

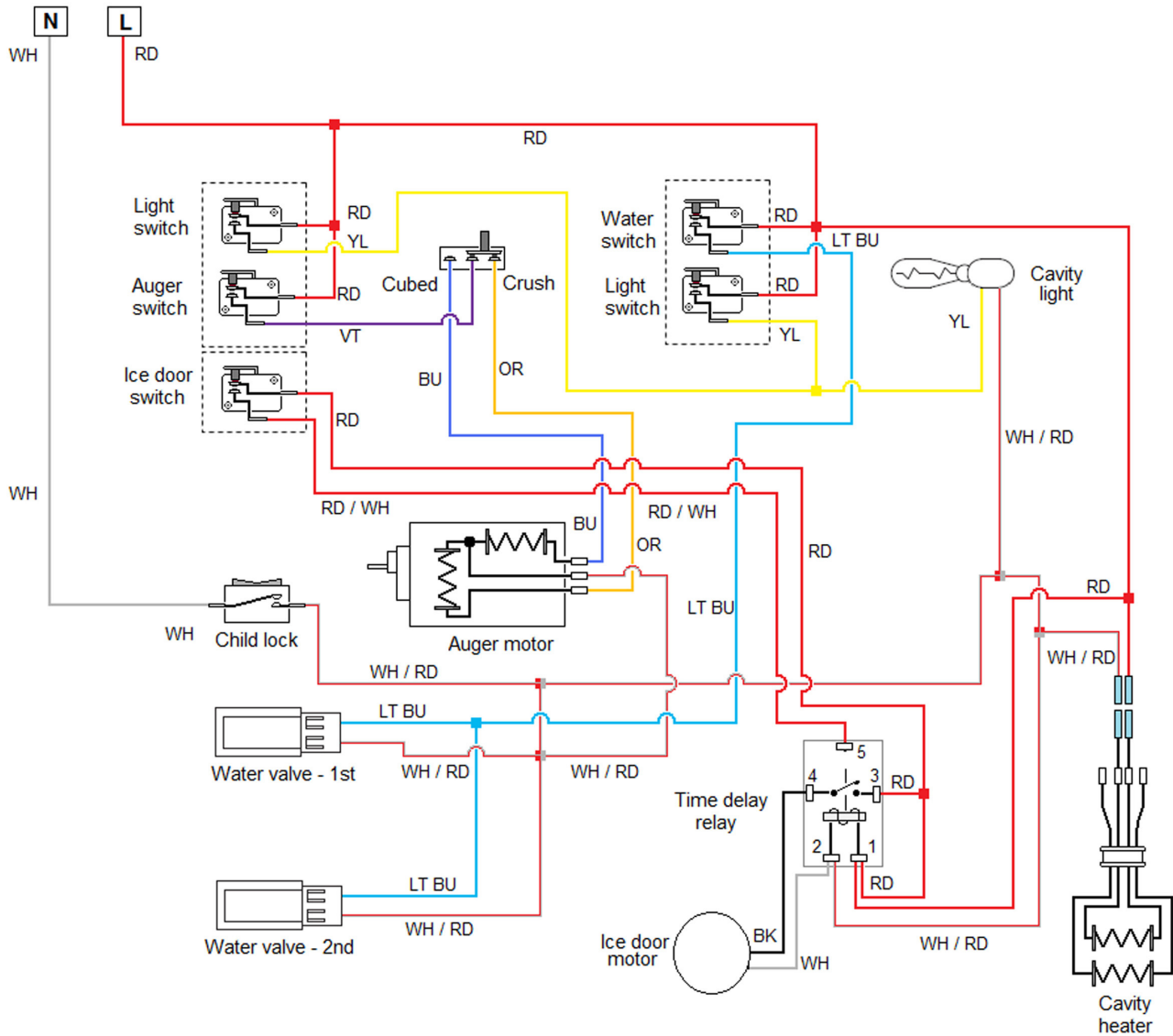

## Wiring and Component testing–High Voltage Board

Terminal	Terminal	Description	Wire Colors	$\Omega$ - V	Volts
1	12	Fresh Food Fan only	Purple to Green w/ Yellow	3.2 m $\Omega$	24 VDC
1	12	Fresh Food Fan AND Service Fan	Purple to Green w/Yellow	1.6 m $\Omega$	24 VDC
2	3	Defrost Heater	Orange to Blue w/White	30.3 $\Omega$	120 VAC
6	10	Freezer Fan -120 VAC	Yellow to White	$\Omega$	
4	11	Defrost Bimetal	Brown to Black	0 or $\infty$	0 or 120 V
5	11	Freezer door switch	Purple w/White to Black	0 or $\infty$	0 or 120 V
7	10	Line out to Inverter board	Blue to White	2 m $\Omega$	120 VAC
8	10	Line out to Condenser fan motor	Brown w/white to White	550 $\Omega$	120 VAC
9	11	Refrigerator door switch	Red w/White to Black	0 or $\infty$	120 VAC
11	10	Main in to HV Board	Black to White	N/A	0 or 120 V
13	*	Neutral OUT to cavity lights	White w/Black	N/A	N/A

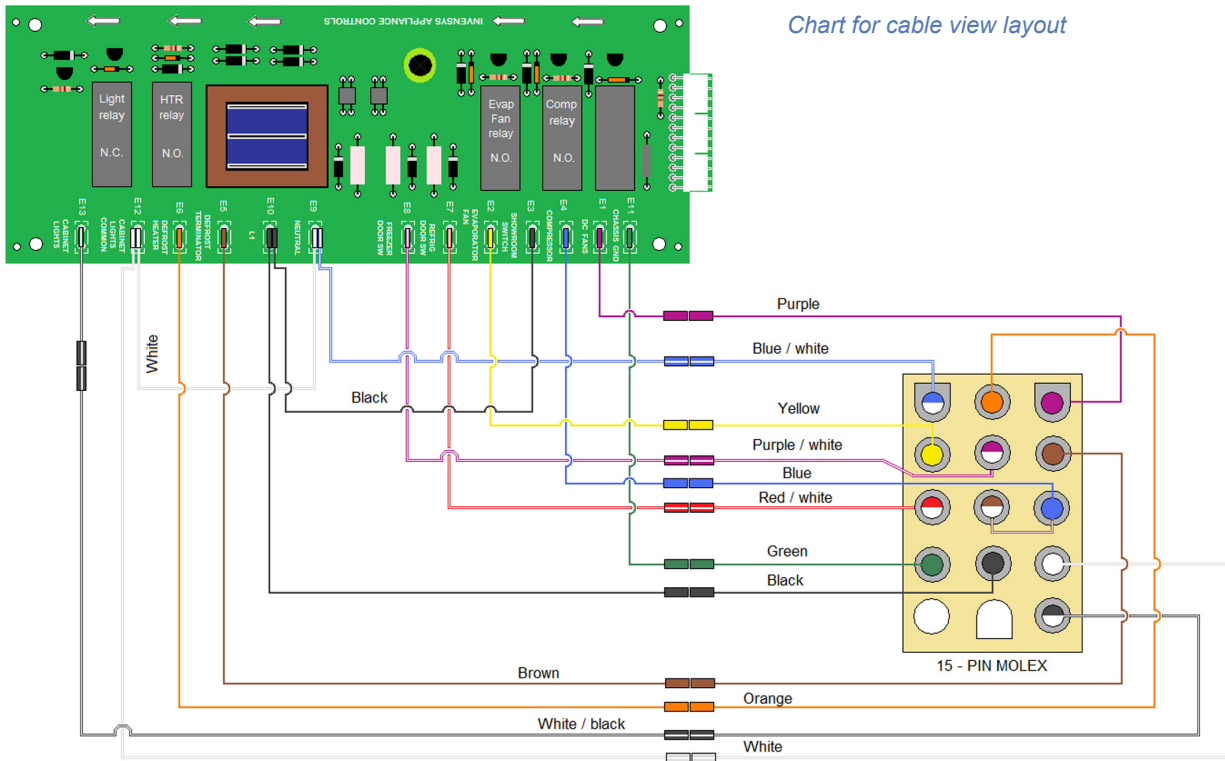
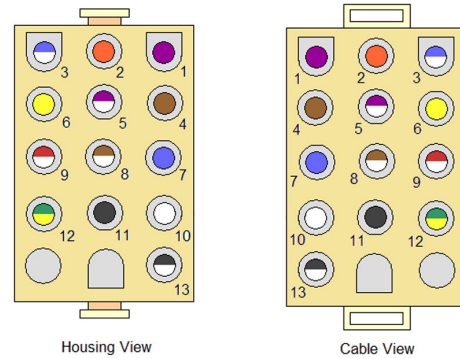
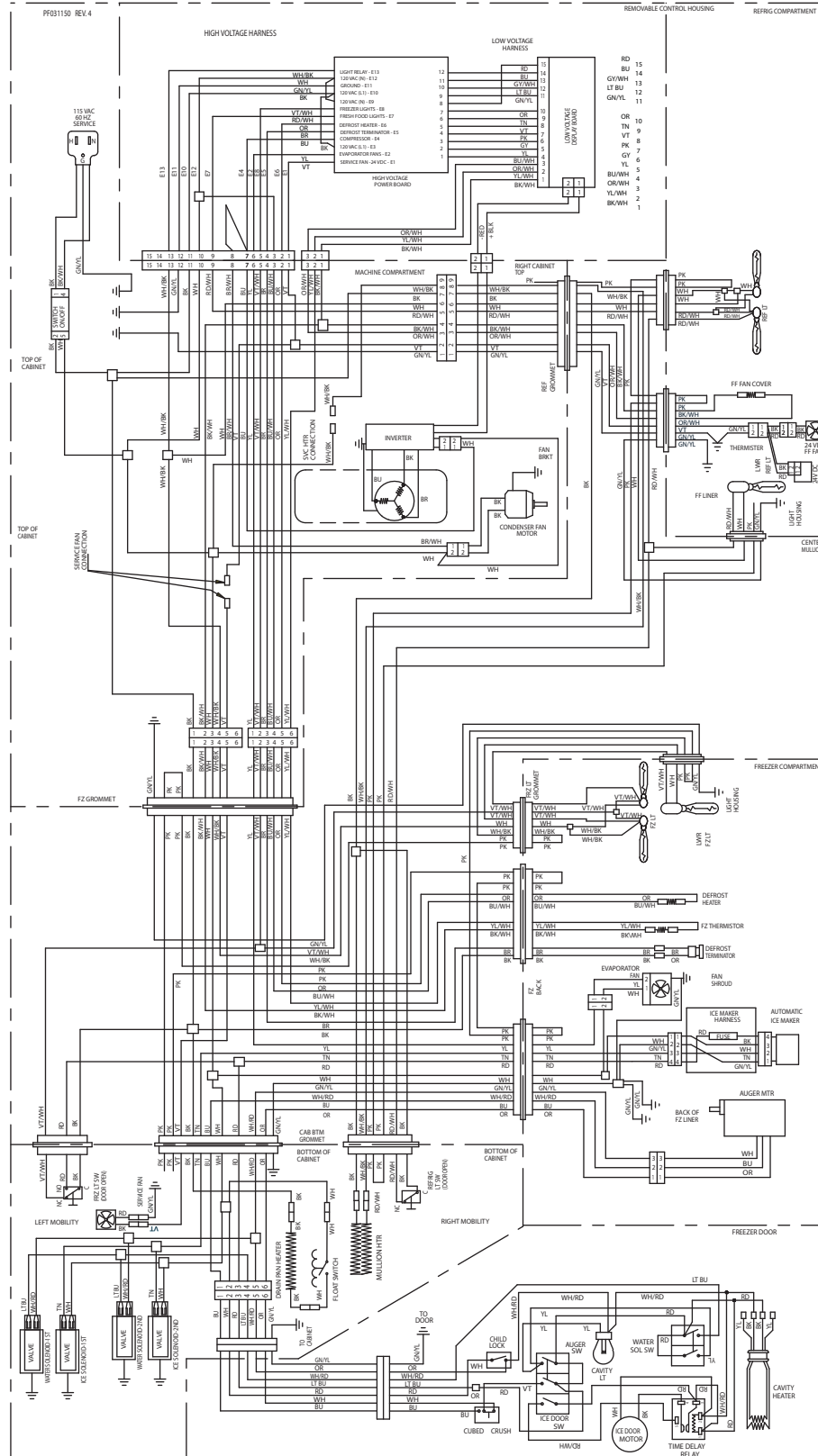

Chart for cable view layout

Molex Connection	Wire Colors	HV Board connection
1	Purple	E1
2	Orange	E6
3	Blue w/White tracer	E9
4	Brown	E5
5	Purple w/White tracer	E8
6	Yellow	E2
7	Blue	E4
8	Brown w/White tracer	E4
9	Red w/White tracer	E1
10	White	E12
11	Black	E10
12	Green w/Yellow tracer	E11
13	White w/Black tracer	E13



## Wiring Diagram with Dispenser



## Wiring Diagram without Dispenser

