



SERVICE NOTEBOOK
Side-by-Side Refrigerators

Models

VCSF036SS

DDSF036SS

VCSF036DSS

DDSF036DSS

SAVE THESE INSTRUCTIONS

REVIEW ALL SERVICE INFORMATION IN THE APPROPRIATE SERVICE MANUAL AND TECHNICAL SHEETS BEFORE BEGINNING REPAIRS.



Pride and workmanship go into every product to provide our customers with quality products. It is possible, however, that during its lifetime, a product may require service. Products should be serviced only by a qualified service technician that is familiar with the safety procedures required in the repair and who is equipped with the proper tools, parts, testing instruments, and the appropriate service manual.

Safety Information

We have provided many important safety messages in this manual and on the appliance. Always read and obey all safety messages. This is the safety alert symbol.



This symbol alerts you to hazards that can kill or hurt you and others. All safety messages will be preceded by the safety alert symbol and the word "DANGER", "WARNING" or "CAUTION". These words mean:

 DANGER
IMMEDIATE HAZARDS WHICH WILL RESULT IN SEVERE PERSONAL INJURY OR DEATH.
 WARNING
Hazards or unsafe practices which COULD result in severe personal injury or death.
 CAUTION
Hazards or unsafe practices which COULD result in minor personal injury or product or property damage.

All safety messages will identify the hazard, tell you how to reduce the chance of injury, and tell you what can happen if the instructions are not followed.

 WARNING
To avoid risk of serious injury or death, repairs should not be attempted by unauthorized personnel.
 CAUTION
VIKING will not be responsible for any injury or property damage from improper service procedures. If performing service on your own product, you must assume responsibility for any personal injury or property damage which may result.

To locate an authorized servicer, call:

Viking Customer Service
Phone No. 1-888-845-4641

Address your written correspondence to:

Viking Preferred Service
1803 HWY 82 West
Greenwood, MS 38930

Freestanding Side-By-Side Refrigerator/Freezer Warranty

TWO YEAR FULL WARRANTY

Freestanding refrigerators/freezers and all of their components and accessories, except as detailed below*, are warranted to be free from defects in material or workmanship under normal household use for a period of two (2) years from the date of original retail purchase. Viking Range Corporation, warrantor, agrees to repair or replace, at its option, any part which fails or is found to be defective during the warranty period *Painted and decorative items are warranted to be free from defective materials or workmanship for a period of ninety (90) days from the date of original retail purchase. ANY DEFECTS MUST BE REPORTED TO THE SELLING DEALER WITHIN NINETY (90) DAYS FROM DATE OF ORIGINAL RETAIL PURCHASE.

SIX YEAR FULL WARRANTY

Any sealed refrigeration system component, as listed below, or any automatic ice maker is warranted to be free from defective materials or workmanship in normal household use during the third through the sixth year from the date of original retail purchase. Viking Range Corporation, warrantor, agrees to repair or replace, at its option, any part which fails or is found to be defective during the warranty period.

Sealed Refrigeration System Components:

Compressor, Evaporator, Condenser, Connecting Tubing, Dryer/Strainer

TWELVE YEAR LIMITED WARRANTY

Any sealed refrigeration system component, as listed above, which fails due to defective materials or workmanship in normal household use during the seventh through the twelfth year from the date of original retail purchase will be repaired or replaced, free of charge for the part itself, with the owner paying all other costs, including labor.

NINETY (90) DAY RESIDENTIAL PLUS WARRANTY This warranty applies to applications where use of the product extends beyond normal residential use. Examples are, but not limited to, bed and breakfasts, fire stations, private clubs, churches, etc. This warranty excludes all commercial locations such as restaurants, food service locations and institutional food service locations.

This warranty extends to the original purchaser of the product warranted hereunder and to each transferee owner of the product during the term of the warranty.

This warranty shall apply to products purchased and located in the United States and Canada. Products must be purchased in the country where service is requested. Warranty labor shall be performed by an authorized Viking Range Corporation service agency or representative. Warranty shall not apply to damage resulting from abuse, accident, natural disaster, loss of electrical power to the product for any reason, alteration, improper installation, improper operation or repair or service to the product by anyone other than an authorized Viking Range Corporation service agency or representative. Warranty shall not apply to damage resulting from indoor units being used in outdoor situations. This warranty does not apply to commercial usage. This warranty does not cover any food or medicine loss due to product failure. Warrantor is not responsible for consequential or incidental damage whether arising out of breach of warranty, breach of contract, or otherwise. Some jurisdictions do not allow the exclusion or limitation of incidental or consequential damages, so the above limitation or exclusion may not apply to you.

Owner shall be responsible for proper installation, providing normal care and maintenance, providing proof of purchase upon request, and making the appliance reasonably accessible for service. If the product or one of its component parts contains a defect or malfunction during the warranty period, after a reasonable number of attempts by the warrantor to remedy the defects or malfunctions, the owner is entitled to either a refund or replacement of the product or its component part or parts. Replacement of a component part includes its free installation. Warrantor's liability on any claim of any kind, with respect to the goods or services covered hereunder, shall in no case exceed the price of the goods or service or part thereof of which gives rise to the claim.

WARRANTY SERVICE: Under the terms of this warranty, service must be performed by a factory authorized Viking Range Corporation service agent or representative. Service will be provided during normal business hours, and labor performed at overtime or premium rates shall not be covered by this warranty. To obtain warranty service, contact the dealer from whom the product was purchased, an authorized Viking Range Corporation service agent, or Viking Range Corporation. Provide model and serial number and date of original purchase. For the name of your nearest authorized Viking Range Corporation service agency, call the dealer from whom the product was purchased or Viking Range Corporation. **IMPORTANT:** Retain proof of original purchase to establish warranty period.

The return of the Owner Registration Card is not a condition of warranty coverage. You, however, should return the Owner Registration Card so that Viking Range Corporation can contact you should any question of safety arise which could affect you.

Any implied warranties of merchantability and fitness applicable to the above described refrigerator are limited in duration to the period of coverage of the applicable express written limited warranties set forth above. Some jurisdictions do not allow limitations on how long an implied warranty lasts, so the above limitation may not apply to you. This warranty gives you specific rights, and you may also have other rights which may vary from jurisdiction to jurisdiction.

Specifications are subject to change without notice.

For more product information, call 1-888-VIKING1 (845-4641), or visit our web site at <http://www.vikingrange.com>

Table of Contents



Important Information	2	<u>Fahrenheit or Celsius Mode</u>	25
<u>Safety Information</u>	2	<u>Show Room Mode</u>	25
General Information	6	<u>Sabbath Mode</u>	25
<u>Fully Electronic Defrost System</u>	6	<u>Alarm Enable Mode</u>	25
<u>Serial Number Location</u>	6	<u>Light Level Mode (Select Models)</u>	25
<u>Installation</u>	6	Component Testing	26
<u>Location</u>	6	System Diagnosis	32
<u>Measuring the Opening</u>	6	<u>Symptoms of an Overcharge</u>	32
<u>Leveling</u>	6	<u>Symptoms of Air in System</u>	32
<u>Leveling doors</u>	6	<u>Symptoms of Refrigeration Shortage</u>	33
Operation	7	<u>Symptoms of Low or High Ambient Temperature</u>	
<u>Climate Controls</u>	7	<u>Installation</u>	33
<u>Initial Temperature Setting</u>	7	Heat Load	33
<u>Adjusting the Control</u>	7	<u>Symptoms of a Restriction</u>	34
<u>Temperature Control Guide</u>	7	Service Procedure	35
<u>Max Ice</u>	7	<u>Service Equipment</u>	35
<u>Water Filter Indicator</u>	7	<u>Leak Testing</u>	35
<u>Vacation Mode</u>	7	<u>Testing Systems Containing a Refrigerant</u>	
<u>Door Open Alarm</u>	7	<u>Charge</u>	35
<u>High Temp Alarm</u>	8	<u>Testing Systems Containing No Refrigerant</u>	
<u>Max Cold</u>	8	<u>Charge</u>	35
<u>User Preferences</u>	8	<u>Refrigerant Precautions</u>	36
<u>Temperature Display “F C”</u>	8	<u>Line Piercing Valves</u>	36
<u>Alarm “AL”</u>	8	<u>Open Lines</u>	36
<u>Auto Light Level Selection “LL”</u>		<u>Compressor Operational Test</u>	36
<u>(select models)</u>	8	<u>Dehydrating Sealed Refrigeration System</u>	37
<u>Sabbath Mode “SAB”</u>	8	<u>Restrictions</u>	37
<u>Warm Cabinet Surfaces</u>	8	<u>Symptoms</u>	37
Dispenser Control Panel	9	<u>Testing for Restrictions</u>	37
<u>Dispenser Light</u>	9	Evacuation and Charging	38
<u>Dispenser Pad</u>	9	<u>Evacuation</u>	38
<u>Removable Tray</u>	9	<u>Charging</u>	39
<u>Water and Ice Dispenser</u>	9	Refrigerant Charge	39
<u>Dispenser Lock</u>	9	HFC134a Service Information	39
<u>Auto Light</u>	9	<u>Health, Safety, and Handling</u>	39
<u>Light</u>	9	<u>Comparison of CFC12 and HFC134a</u>	
<u>Sabbath Mode</u>	9	<u>Properties</u>	40
Care and Cleaning	10	Brazing	40
<u>Refrigerator Cleaning Chart</u>	10	Replacement Service Compressor	41
<u>Operating Sounds</u>	11	<u>Compressor Testing Procedures</u>	41
Troubleshooting Chart	12	Drier Replacement	41
<u>Dispenser Troubleshooting Chart</u>	18	<u>Refrigerant Flow</u>	42
<u>Seconds to dispense 10 oz. water</u>	22	<u>Cabinet Air Flow</u>	43
Control Board	23	<u>Water and Ice Dispenser</u>	44
<u>Programming Mode</u>	23	Disassembly Procedures	45
<u>Defrost Operation</u>	23	<u>Upper Refrigerator Section Light Bulb Removal</u> ..	45
<u>Forced Defrost Mode</u>	23	<u>Crisper Section Light Bulb Removal</u>	45
<u>Service Test Mode</u>	23	<u>Light Switch Removal</u>	45
		<u>Electronic Control Removal</u>	45

<u>Electronically Controlled Damper Removal</u>	46	<u>Condensate Drain Tube</u>	52
<u>Refrigerator Thermistor Removal</u>	46	<u>Overload/Relay Removal</u>	52
<u>Crisper Light Cover and Socket Removal</u>	46	<u>Compressor Removal</u>	52
<u>Water Filter Removal</u>	47	<u>Condenser Fan Motor and Blade Removal</u>	53
<u>Initial Installation</u>	47	<u>Condensate Drip Pan Removal</u>	53
<u>Replacing Water Filter</u>	47	<u>Condenser Removal</u>	53
<u>Access to Machine Compartment</u>	47	<u>Front and Rear Leveling Rollers Removal</u>	54
<u>Water Filter Assembly Removal</u>	47	<u>Door Gasket Removal</u>	54
<u>Water Tank Assembly Removal</u>	48	<u>Dispenser Light Bulb Removal</u>	54
<u>Water Valve Removal</u>	48	<u>Dispenser Façade Removal</u>	54
<u>Upper Freezer Section Light Bulb Removal</u>	49	<u>Dispenser Light Socket</u>	54
<u>Auger Motor Assembly Removal</u>	49	<u>Dispenser Pad and Switch Removal</u>	55
<u>Upper Freezer Light Socket Removal</u>	49	<u>Dispenser Board Removal</u>	55
<u>Auger Motor Capacitor Removal</u>	49	<u>Dispenser Ice Chute Door and Solenoid</u>	
<u>Lower Freezer Section Light Bulb Removal</u>	49	<u>Removal</u>	55
<u>Auger Motor Removal</u>	50	<u>Dispenser Water Tube Removal</u>	56
<u>Evaporator Fan Motor Assembly</u>	50	<u>Door and Hinge Removal</u>	56
<u>Evaporator Fan Motor and Fan Blade</u>	50	<u>Door Handle Removal</u>	57
<u>Defrost Thermostat Removal</u>	50	<u>Door Handle Installation</u>	57
<u>Defrost Heater Removal</u>	51	Appendix A	58
<u>Evaporator Removal</u>	51		
<u>Ice Maker Removal</u>	51		
<u>Freezer Thermistor Removal</u>	52		

Fully Electronic Defrost System

The Control Board adapts the compressor run time between defrosts to achieve optimum defrost intervals by monitoring the length of time the defrost heater is on. After initial power up, defrost interval is 4 hours compressor run time. Defrost occurs immediately after the 4 hours. Once unit is ready to defrost there is a 4 minute wait time prior to the beginning of the defrost cycle.

Serial Number Location

The model number and serial number are located on the data plate. The data plate is located in the refrigerator compartment on the upper left side.

Installation

Location

Do not install refrigerator near oven, radiator or other heat source. If this is not possible, shield the refrigerator with cabinet material.

Do not install where temperature falls below 55° F or rises above 110° F. Malfunction may occur at this temperature.

Refrigerator is designed for indoor household application only.

Measuring the Opening

When installing your refrigerator, allow ½" space at top and ½" space behind machine compartment cover (located in the rear) for proper air circulation. If the refrigerator is placed with the door hinge side against a wall, you may want to allow additional space so the door can be opened wider.

Subflooring or floor coverings (i.e. carpet, tile, wood floors, rugs) may make your opening smaller than anticipated.

Some clearance may be gained by using the leveling procedure under Leveling.

IMPORTANT: If refrigerator is to be installed into a recess where the top of the refrigerator is completely covered, use dimensions from floor to top of hinge cap to verify proper clearance.

Leveling



Use care when leveling the refrigerator to avoid damaging the floor or refrigerator.

To enhance the appearance and maintain performance, the refrigerator should be level.

NOTE: Complete any required door reversal, panel installation and/or a water supply connection, before leveling.

1. Remove the toe grille.
2. Turn the front adjustment screws clockwise to raise and counterclockwise to lower the front of the refrigerator.
3. Turn the rear adjustment screws clockwise to raise and counterclockwise to lower the rear of the refrigerator.
4. Using a level, make sure front of refrigerator is ¼" or ½ bubble higher than back of refrigerator and that the refrigerator is level from side to side.
5. If required, correct rocking of refrigerator by turning rear adjustment screw clockwise to raise rocking corner.

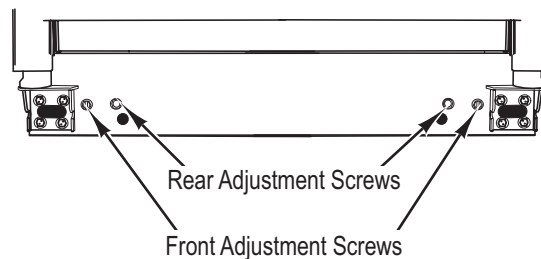

Leveling doors

1. Turn front adjustment screw clockwise to raise front corner of door.
2. If one refrigerator door has reached the limit of its adjustment range and doors are still not level, raise or lower the opposite door by turning roller adjustment screw counterclockwise.
3. Check with level to verify ¼" tilt to the back for proper door closure.
4. If refrigerator is aligned and stable, replace toe grille.

Operation

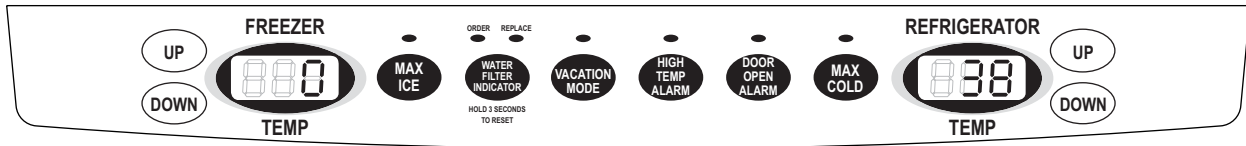

Climate Controls

The control panel is located at the top front of the refrigerator compartment.

Initial Temperature Setting

Temperatures are preset at the factory at 38° F in the refrigerator compartment and 0° F in the freezer compartment.

Adjusting the Control

24 hours after adding food, you may decide that one or both compartments should be colder or warmer. If so, adjust the control as indicated in the Temperature Control Guide below.

The first touch of the UP or DOWN buttons shows the current temperature setting.

The display will show the new setting for approximately three seconds, and then return to the actual temperature currently within that compartment.

Do not change the temperature in either compartment more than one degree at a time. Allow temperature to stabilize for 24 hours before making a new temperature adjustment.

Temperature Control Guide

Refrigerator too cold	Set the refrigerator control to next higher number by pressing the UP button.
Refrigerator too warm	Set the refrigerator control to next lower number by pressing the DOWN button.
Freezer too cold	Set the freezer control to next higher number by pressing the UP button.
Freezer too warm	Set the freezer control to next lower number by pressing the DOWN button.
Turn refrigerator off	Press the FREEZER TEMP UP button until "OFF" appears in the display. Press the FREEZER TEMP DOWN button to turn back on.

Max Ice

When activated, Max Ice reduces the freezer temperature to the optimum setting for 24 hours in order to produce more ice.

NOTE: When the Max Ice feature is in operation, the UP and DOWN buttons for the freezer control will not operate.

Water Filter Indicator

When a water filter is installed in the refrigerator, the yellow ORDER light will illuminate when:

- 90 percent of the volume of water has passed through the filter
- 11 months have elapsed since the filter was installed.

The red REPLACE light will illuminate when:

- the rated volume of water has passed through the filter
- 12 months have elapsed since the filter was installed.

A new filter should be installed immediately when the REPLACE light is illuminated.

After replacing the filter, press and hold the WATER FILTER INDICATOR button for three seconds. The ORDER and REPLACE lights will go off.

Vacation Mode

The Vacation Mode feature causes the freezer to defrost less frequently, conserving energy. The VACATION MODE indicator light will illuminate when the feature is activated. To deactivate, press the VACATION MODE button again OR open either door. The indicator light will go off.

NOTE: Door openings will not deactivate Vacation Mode for approximately one hour after activation.

Door Open Alarm

The Door Open Alarm will alert you when one of the doors has been left open for five continuous minutes. When this happens, an audible alarm will sound every few seconds until the door is closed OR the DOOR OPEN ALARM button is pressed to deactivate the feature.

High Temp Alarm

The High Temp Alarm system will alert you if the freezer or refrigerator temperatures exceed normal operating temperatures due to a power outage or other event. When activated, the HIGH TEMP ALARM light will illuminate.

If the freezer or refrigerator temperatures have exceeded these limits, the display will alternately show the current compartment temperatures and the highest compartment temperatures reached when the power was out. An audible alarm will sound repeatedly.

Press the HIGH TEMP ALARM button once to stop the audible alarm. The HIGH TEMP ALARM light will continue to flash and the temperatures will alternate until the temperatures have stabilized.

To turn off HIGH TEMP ALARM, press and hold the HIGH TEMP ALARM button for three seconds. The indicator light will go off.

Max Cold

When activated, Max Cold causes the refrigerator and freezer temperatures to drop to the minimum settings on the control. This cools down the refrigerator and freezer after extended door openings or when loading the refrigerator or freezer with warm food.

NOTE: When the Max Cold feature is in operation, the UP and DOWN buttons for the refrigerator and freezer controls will not operate.

To activate, press the MAX COLD button. MAX COLD will deactivate automatically after 12 hours, OR press the MAX COLD button to deactivate the feature.

User Preferences

Access the User Preferences menu to:

- Change the temperature display from °F to °C
- Enable or disable audible alarms.
- Adjust the light level at which the Dispenser Auto Light will illuminate (when this feature is activated on the ice and water dispenser) (select models)
- Activate the Sabbath Mode

To access the User Preferences menu:

1. Press and hold the DOOR OPEN ALARM button for three seconds.

NOTE: When in the User Preferences mode, a short title for the feature will appear in the FREEZER TEMP display and the feature status will appear in the REFRIGERATOR TEMP display.

2. Use the FREEZER TEMP UP and DOWN buttons to scroll through the features.

3. When the desired feature is displayed, use the REFRIGERATOR TEMP UP and DOWN buttons to change the status.
4. When changes are complete, press THE DOOR OPEN ALARM button for three seconds OR close the door.

Temperature Display “F_C”

Change the display to show temperatures in degrees Fahrenheit or degrees Celsius.

Alarm “AL”

When the Alarm mode is “OFF”, all audible alarms will be disabled until the feature is turned on.

Auto Light Level Selection “LL” (select models)

This setting adjusts the light level at which the dispenser light will illuminate. Setting “1” is the darkest light level setting, setting “9” is the lightest light level setting. The AUTO LIGHT (select models) must be activated on the ice and water dispenser control to take advantage of this option.

Sabbath Mode “SAB”

When the Sabbath Mode is “On”, all control lights and the night light will be disabled until the feature is turned “OFF”. This feature does not disable the interior lights. Press any pad to restore the control lights.

Warm Cabinet Surfaces

At times, the front of the refrigerator cabinet may be warm to the touch. This is a normal occurrence that helps prevent moisture from condensing on the cabinet. This condition will be more noticeable when the refrigerator is first started, during hot weather and after excessive or lengthy door openings.

Dispenser Control Panel



Dispenser Light

A light activates within the dispenser area at full power when dispensing ice or water with the dispenser pad.

Dispenser Pad

The Dispenser Pad is located on the back wall of the dispensing area. When the dispenser pad is pressed, the selection chosen on the dispenser control panel will dispense.

Removable Tray

The Removable Tray at the bottom of the dispenser area is designed to collect small spills and may be easily removed for cleaning and emptying purposes.

IMPORTANT: Removable tray does not drain. Do not allow tray to overflow. If it does, remove tray and wipe up overflow.

Water and Ice Dispenser

To Use Dispenser Pad:

- Select WATER, CRUSHED ICE, or CUBED ICE mode by pushing button on dispenser control panel. A green light above button indicates mode selection.
- Press against dispenser pad.
- Release pressure on dispenser pad to stop dispensing.
- If dispenser is active for more than five minutes, an automatic lock out sensor will shut down power to dispenser area.

Dispenser Lock

The Dispenser Lock prevents ice or water from being dispensed.

To Lock Dispenser:

- Press and hold the LOCK/UNLOCK button for three seconds. A green indicator light above button will illuminate when the dispenser is locked.

To Unlock Dispenser:

- Hold the LOCK/UNLOCK button for three seconds. The green indicator light above button will go out.

Auto Light

The Auto Light function activates the dispenser light at half-power when the light sensor detects that the light levels in room are low.

To Activate Auto Light:

- Press LIGHT button. A green indicator light above AUTO illuminates when the sensor is active.

To Deactivate Auto Light:

- Press LIGHT button. The green indicator light will go out.

NOTE: The dispenser light will operate when Auto Light is ON or OFF.

Light

To Activate Light:

- Press the LIGHT button again to turn the dispenser light on continuously. The ON indicator light will illuminate.

To Deactivate Light:

- Press the LIGHT button again to turn the dispenser light off.

Sabbath Mode

When activated, the Sabbath Mode deactivates the control lights while leaving the control operational.

To Activate Sabbath Mode:

- Press and hold the LOCK/UNLOCK and LIGHT buttons simultaneously for three to four seconds. After three to four seconds, the dispenser lights will turn off.

To Deactivate Sabbath Mode:

- Press and hold both the LOCK/UNLOCK and LIGHT buttons simultaneously for three to four seconds. After three to four seconds, the dispenser lights will activate.

NOTE: Dispenser light will not activate during dispensing while in this mode.

NOTE: If the power fails, the control will remain in Sabbath Mode when power returns.

Care and Cleaning

WARNING

To avoid risk of electrical shock which can cause severe personal injury or death, disconnect power to unit before cleaning.

CAUTION

Only use recommended cleaning products. Do not place buckets, shelves, or accessories in a dishwasher. Cracking or warping may result.

Refrigerator Cleaning Chart

PART	DO NOT USE	DO
Cabinet Interior	Abrasive or harsh cleaners Ammonia Chlorine bleach Concentrated detergents or solvents Metal or plastic-textured scouring pads	Use 4 tablespoons of baking soda dissolved in 1 quart warm soapy water. Rinse surfaces with clean warm water and dry immediately to avoid water spots.
Stainless Steel Doors and Exterior IMPORTANT: Damage to stainless steel finish due to improper use of cleaning products or non-recommended products is not covered under this product's warranty.	Abrasive or harsh cleaners Ammonia Chlorine bleach Concentrated detergents or solvents Metal or plastic-textured scouring pads Vinegar-based products Citrus-based cleaners	Use warm, soapy water and a soft, clean cloth or sponge. Rinse surfaces with clean warm water and dry immediately to avoid water spots. To polish and help prevent fingerprints, follow with Stainless Steel Magic Spray.
Door Gaskets	Abrasive or harsh cleaners Metal or plastic-textured scouring pads	Use warm, soapy water and a soft, clean cloth or sponge.
Condenser Coil Remove base grille to access.		Use a vacuum cleaner hose nozzle.
Condenser Fan Outlet Grille See back of refrigerator.		Use a vacuum cleaner hose nozzle with brush attachment.
Accessories Shelves, buckets, drawers, etc.	A dishwasher	Follow removal and installation instructions from appropriate feature section. Allow accessories to adjust to room temperature. Dilute mild detergent and use a soft clean cloth or sponge for cleaning. Use a plastic bristle brush to get into crevices. Rinse surfaces with clean warm water. Dry glass and clear items immediately to avoid spots.

Operating Sounds

Improvements in refrigeration design may produce sounds in your new refrigerator that are different or were not present in an older model. These improvements were made to create a refrigerator that is better at preserving food, is more energy efficient, and is quieter overall. Because new units run quieter, sounds may be detected that were present in older units, but were masked by higher sound levels. Many of these sounds are normal. Please note that the surfaces adjacent to a refrigerator, such as hard walls, floors and cabinetry may make these sounds seem even louder. The following are some of the normal sounds that may be noticed in a new refrigerator.

SOUND	POSSIBLE CAUSE	SOLUTION
Clicking	Freezer control clicks when starting or stopping compressor.	Normal operation
	Defrost timer or electric damper control sounds like an electric clock and snaps in and out of defrost cycle.	Normal operation
Air rushing or whirring	Condenser fan makes this noise while operating.	Normal operation
	Freezer fan makes this noise while operating.	Normal operation
	Freezer fan slows to a stop as the freezer door is opened.	Normal operation
Gurgling or boiling sound	Evaporator and heat exchanger refrigerant make this noise when flowing.	Normal operation
Thumping	Ice cubes from ice maker drop into ice bucket.	Normal operation
	Dispenser ice chute closing.	Normal operation
Vibrating noise	Compressor makes a pulsating sound while running.	Normal operation
	Refrigerator is not level.	See Leveling.
Buzzing	Ice maker water valve hookup buzzes when ice maker fills with water.	Normal operation
Humming	Ice maker is in the ON position without water connection.	Stop sound by raising ice maker arm to OFF position.
	Ice auger hums as auger agitates ice during dispensing.	Normal operation
	Compressor can make a high pitched hum while operating.	Normal operation
	Solenoid valve operating ice chute door.	Normal operation

Troubleshooting Chart



Symptom	Possible Cause	Corrective Action
Freezer control and lights are on, but compressor is not operating	Unit is in defrost mode.	Normal operation. Wait 40 minutes to see if compressor restarts.
Temperature-controlled drawers are too warm	Control settings are too low.	Adjust controls.
	Freezer controls are set too low.	Adjust controls.
	Drawer is improperly positioned.	Verify drawer positioning.
Refrigerator does not operate	Refrigerator is not plugged in.	Plug in refrigerator.
	Touch temperature controls are set to “-”.	Adjust controls.
	Fuse is blown, or circuit breaker needs to be reset.	Replace any blown fuses. Check circuit breaker and reset, if necessary.
	Power outage has occurred.	Call local power company to report outage.
Refrigerator still won't operate	Unit is malfunctioning.	Unplug refrigerator and transfer food to another refrigerator. If another refrigerator is not available, place dry ice in freezer section to preserve food. Warranty does not cover food loss.
Water droplets form on outside of refrigerator	Door gaskets are not sealing properly.	Clean door gasket.
	Humidity levels are high.	Normal during times of high humidity.
	Controls require adjustment.	Adjust controls.
Food temperature is too cold	Condenser coils are dirty.	Clean coils.
	Refrigerator or freezer temperatures are set too high.	Adjust controls.
	Food is too close to upper left air inlet.	Relocate food.
Refrigerator has an odor	Odor producing foods should be covered or wrapped.	Clean interior.
	The interior needs cleaning.	
Food temperature is too warm	Door is not closing properly.	Refrigerator is not level. Level refrigerator.
		Check gaskets for proper seal. Clean, if necessary.
		Check for internal obstructions that are keeping door from closing properly.
	Controls need to be adjusted.	Adjust controls.
	Condenser coils are dirty.	Clean coils.
	Rear air grille is blocked.	Check the positioning of food items.
	Door has been opened frequently, or has been opened for long periods of time.	Reduce time door is open. Organize food items efficiently to assure door is open for as short a time as possible.
	Food has recently been added.	Allow time for recently added food to reach refrigerator or freezer temperature.

Symptom	Possible Cause	Corrective Action	
Water droplets form on inside of refrigerator	Humidity levels are high or door has been opened frequently.	Reduce time door is open. Organize food items efficiently to assure door is open for as short a time as possible.	
	Door gaskets are not sealing properly.	Clean door gasket.	
Refrigerator or ice maker makes unfamiliar sounds or seems too loud	Normal operation.	See Operating Sounds.	
Temperature-controlled drawer and/or crisper drawer do not close freely	Contents could be obstructing drawer.	Reposition food items and containers to avoid interference with the drawers.	
	Drawer is not in proper position.	Verify drawer positioning.	
	Refrigerator is not level.	See Leveling.	
	Drawer channels are dirty.	Clean drawer channels with warm, soapy water. Rinse and dry thoroughly. Apply a thin layer of petroleum jelly to drawer channels.	
Refrigerator runs too frequently	Doors have been opened frequently or for long periods time.	Reduce time door is open. Allow interior environment to adjust for period the door has been opened.	
	Humidity or temperature in surrounding area is high.	Normal operation.	
	Food has recently been added.	Allow time for recently added food to reach refrigerator or freezer temperature.	
	Refrigerator is exposed to heat by environment or by appliances nearby.	Evaluate your refrigerator's environment. Refrigerator may need to be moved to run more efficiently.	
	Condenser coils are dirty.	Clean coils.	
	Controls need to be adjusted.	Adjust controls.	
	Door is not closing properly.	Door gaskets not sealing properly.	Refrigerator is not level. Level refrigerator.
			Check for internal obstructions that are keeping door from closing properly.
	No indicator lights are lit on dispenser control	Freezer door is not closed.	Verify that freezer door is closed. Power is removed from the control when freezer door is opened.
Refrigerator is not plugged in.		Plug in refrigerator.	
Fuse is blown, or circuit breaker needs to be reset.		Replace any blown fuses. Check circuit breakers for any tripped circuits.	
Power outage has occurred.		Call local power company to report outage.	
Refrigerator is in Sabbath Mode.		See Sabbath Mode.	

Troubleshooting Chart



Symptom	Possible Cause	Corrective Action
Ice or water are not dispensed when pads are pressed	Freezer door is not closed.	Verify that freezer door is closed. Power is removed from the control when freezer door is opened.
	Controls are in lock mode.	See Dispenser Lock.
	Water tank is filling.	At initial use, there is an approximate one- to two minute delay in dispensing while the internal water tank is filling.
	Ice maker has just been installed or a large amount of ice has been used.	Wait 24 hours for ice production to begin or for ice maker to restock after emptied.
	Water filter is clogged or needs to be changed.	Change water filter.
Ice maker is not producing enough ice or ice is malformed	Ice maker has just been installed or a large amount of ice has been used.	Wait 24 hours for ice production to begin or for ice maker to restock after emptied.
	Water pressure is too low.	Check water pressure requirements.
	Water filter is clogged or needs to be changed.	Change water filter.
Ice maker is not producing ice	Ice maker arm is up.	Confirm ice maker arm is down.
	Household water supply is not reaching water valve.	See Connecting the Water Supply.
	Copper tubing has kinks.	Turn off water supply and remove kinks. If kinks cannot be removed, replace tubing.
	Water pressure is too low.	Check water pressure requirements.
	Check freezer temperature.	Adjust temperature.
	Ice bin is not installed properly.	Check position of ice bin.
	Improper water valve was installed.	See Connecting the Water Supply.
Water filter indicator light is red	Water filter needs to be replaced.	Change water filter.
	Filter indicator sensor needs to be reset.	See Filter Status Indicator Light.
Water flow is slower than normal	Water pressure is low.	Check water pressure requirements.
	Saddle valve not open completely.	Open saddle valve completely.
	Improper water valve was installed.	See Connecting the Water Supply.
	Copper tubing has kinks.	Turn off water supply and remove kinks. If kinks cannot be removed, replace tubing.
	Water filter is clogged or needs to be changed.	Change water filter.
	Water valve not opened completely.	Open water valve completely and check for leaks. The minimum flow at dispenser is approximately 10 fluid ounces in nine seconds with a new filter in place or approximately 10 fluid ounces in five seconds without a filter.
Water appears cloudy	Air or air bubbles in water.	This is normal when first using the dispenser and will disappear with use.

Symptom	Possible Cause	Corrective Action
Ice forms in inlet tube to ice maker	Water pressure is low.	Check water pressure requirements.
	Saddle valve not open completely.	Open saddle valve completely.
	Freezer temperature is too high.	Adjust temperature.
Refrigerator is leaking water	Plastic tubing was used to complete water connection.	The manufacturer recommends using copper tubing for installation.
	Improper water valve was installed.	See Connecting the Water Supply.
Dispenser water is not cold	Refrigerator has been recently installed.	Allow approximately 12 hours for water in holding tank to chill.
	Water supply in holding tank has been depleted.	
	Water has settled into water lines outside holding tank and has warmed to room temperature.	Discard first glass of water and refill.
Particles in water and/or ice cubes	Carbon dust from water filter cartridge.	Initial water ejected through cartridge may contain harmless carbon dust flushed from cartridge. Particles are safe for consumption. Will disappear after the first few uses.
	Concentrations of minerals in water will form particles when water becomes frozen and melts.	Particles are not harmful and naturally occur in water supplies.
Unit does not run	No power to unit	Check for power at outlet. Check fuse box/circuit breaker for blown fuse or tripped breaker. Replace or reset.
	Faulty power cord	Check with test light at unit; if no circuit and current is indicated at outlet, replace or repair.
	Low voltage	Check input voltage for proper voltage. Take appropriate action to correct voltage supply problem.
	Faulty motor or temperature control	Check all connections are tight and secure. Replace if necessary.
	Faulty relay	Check relay. Replace if necessary.
	Faulty compressor	Check compressor motor windings for opens/shorts. Perform compressor direct wiring test. Replace if necessary.
	Faulty overload	Check overload for continuity. Ensure compressor/overload are below trip temperature before testing. Replace if necessary.
Freezer and refrigerator sections too warm	Temperature controls set too warm	Reset temperature controls.
	Poor door seal	Level cabinet. Adjust hinges. Replace gasket.
	Dirty condenser or obstructed grille	Check condenser and grille. Clean.
	Faulty control	Test control. Replace if failed.
	Refrigerant shortage or restriction	Check for leak or restriction. Repair, evacuate and recharge system.

Troubleshooting Chart



Symptom	Possible Cause	Corrective Action
Refrigerator section too warm	Excessive door opening	Consumer education.
	Overloading of shelves	Consumer education.
	Warm or hot foods placed in cabinet	Consumer education.
	Cold control set too warm	Set control to colder setting.
	Poor door seal	Level cabinet. Adjust hinges. Replace gasket.
	Refrigerator airflow	Check damper is opening by removing grille. With door open, damper should open. Replace if faulty.
	Interior light remains on	Check switch. Replace if necessary.
	Faulty condenser fan or evaporator fan	Check fan and wiring. Replace if necessary.
Refrigerator section too cold	Faulty compressor	Replace compressor.
	Refrigerator temperature control set too cold	Adjust refrigerator temperature control.
Frost or ice on evaporator	Refrigerator airflow not properly adjusted	Check air flow.
	Defrost thermostat faulty	Check defrost thermostat. Replace if failed.
	Evaporator fan faulty	Check fan motor. Replace if failed.
	Defrost heater remains open	Check defrost heater continuity. Replace if failed.
	Defrost control faulty	Check control and replace if failed.
	Open wire or connector	Check wiring and connections. Repair as necessary.
Unit starts and stops frequently (cycles on and off)	Refrigerant shortage or restriction	Check for leak or restriction. Repair, evacuate and recharge system.
	Loose wire or thermostat connections	Check wiring and connections. Repair as necessary.
	Supply voltage out of specification	Check input voltage. Correct any supply problems.
	Overload protector open	Check overload protector for continuity. If open, replace overload. Ensure overload/compressor are below trip temperature before testing.
	Faulty compressor motor capacitor (some compressors do not require motor capacitor)	Check capacitor for open/short. Replace if necessary. Discharge capacitor before testing.
	Faulty fan motor	Check fan motor. Replace if failed.
	Restricted air flow	Check condenser and grille for dirt. Clean.
	Refrigerant shortage or restriction	Check for leak or restriction. Repair, evacuate and recharge system.

Symptom	Possible Cause	Corrective Action
Freezer section too cold	Freezer temp control set too cold	Adjust freezer temperature control.
	Faulty control	Test control. Replace if failed.
Unit runs continuously	Temperature control set too cold	Adjust temperature control.
	Dirty condenser or obstructed grille	Check condenser and grille. Clean.
	Poor door seal	Level cabinet. Adjust hinges. Replace gasket.
	Interior light remains on	Check switch. Replace if necessary.
	Faulty condenser fan or evaporator fan	Check fan and wiring. Replace if necessary.
	Faulty control	Test control. Replace if failed.
	Refrigerant shortage or restriction	Check for leak or restriction. Repair, evacuate and recharge system.
	Refrigerant overcharge	Check for overcharge. Evacuate and recharge system.
	Air in system	Check for low side leak. Repair, evacuate and recharge system.
Unit runs continuously. Temperature normal	Ice on evaporator	Defrost unit.
Unit runs continuously. Temperature too cold	Faulty defrost thermostat	Check thermostat. Replace if necessary.
Noisy operation	Loose flooring or floor not firm	Repair floor or brace floor.
	Cabinet not level	Level cabinet.
	Tubing in contact with cabinet, other tubing, or other metal	Adjust tubing.
	Drip pan vibrating	Adjust drain pan.
	Fan hitting another part	Ensure fan properly aligned and all attaching hardware and brackets are tight and not worn. Tighten or replace.
	Worn fan motor bearings	Check motor for worn bearings. Replace if necessary.
	Compressor mounting grommets worn or missing. Mounting hardware loose or missing	Tighten hardware. Replace grommets if necessary.
	Free or loose parts causing or allowing noise during operation	Inspect unit for parts that may have worked free or loose or missing screws. Repair as required.

Dispenser Troubleshooting Chart

Symptom	Possible Cause	Test Procedure	Corrective Action
No LED lit.	Switch failure in freezer door.	With unit powered, open freezer door. Press freezer door switch in. If freezer light does not turn off, switch is defective.	Replace switch.
	Incorrect harness wiring.	Verify wire color on MPCB 10-pin connector (J4) and 4 pin connector (J1). Refer to Table A. Verify wire color on Fountain Display Board 4-pin (J1) and 2-pin (J2) connectors.	Correct wiring.
	No power to the Fountain Display Board.	With unit powered, measure voltage between pin-3 (RD/BK) wire and pin-1 (BK/GN) wire on Fountain Display Board. Meter should read 12VDC.	Replace Fountain Display Board if meter reads 12 VDC. No 12 VDC, repair open connection or replace MPCB.
No dispenser light when water dispenser pad is pressed in Water, Crushed, or Cubed mode.	No continuity.	Disconnect power. Measure continuity between VT/BK wire of door 6-pin connector and WH wire of door 2-pin connector.	Replace bulb or repair open connection.
	Failed light bulb or Fountain Display Board.	With unit powered, press the Main dispenser switch. Measure voltage on VT/BK wire of door 6-pin connector and WH wire of door 2-pin connector. Voltage should read 120 VAC.	Replace dispenser light bulb or Fountain Display Board if voltage reads 120 VAC. No 120VAC, repair open connection or replace MPCB.
Dispenser light is on (light selections off) without pressing the Main or Water dispenser switch in Water, Crushed, or Cubed mode.	Failed Main dispenser switch (failed short).	Disconnect power. Remove both leads from the switch and measure resistance across switch terminals. Resistance should read less than 1 Ω in this position and higher than 10 M Ω when switch is open.	Replace switch.
	Failed Fountain Display Board.	With unit powered, measure voltage on VT/BK wire of door 6-pin connector and WH wire of door 2-pin connector. Voltage should read 0 VAC.	120 VAC or 1/2 the AC power supply voltage present, replace Fountain Display Board or MPCB.
Water LED is illuminated but does not dispense water when Main dispenser switch is pressed.	Failed Main dispenser switch (failed open).	Disconnect power. Remove both leads from the switch and measure resistance across switch terminals. Resistance should read less than 1 Ω in this position and higher than 10 M Ω when switch is open.	Replace switch.
	Failed Fountain display board or MPCB	With unit powered, close main dispenser switch and press water pad. Measure 12 VDC between pin-1 (BK/GN) to pin-4 (LT/BU) on Fountain Display Board.	No 12 VDC, replace Fountain Display Board. 12 VDC present, check for 120 VAC on J1 pin-1 (YL/WH) on MPCB. No 120 VAC, replace MPCB.

Symptom	Possible Cause	Test Procedure	Corrective Action
Water starts to dispense as soon as Water mode is selected without pressing the Main dispenser switch.	Failed Main dispenser switch (failed short).	Disconnect power. Remove both leads from the switch and measure resistance across switch terminals. Resistance should read less than 1 Ω in this position and higher than 10 M Ω when switch is open.	Replace switch.
	Failed Fountain Display Board.	With unit powered, measure voltage on pin-4 (LT/BU) to pin-1 (BK/GN) on Fountain Display Board. Voltage should read 0 VDC.	If 12 VDC present replace Fountain Display Board. If 0 VDC present, replace MPCB.
Cubed LED is illuminated but does not dispense cubed ice when Main dispenser switch is pressed.	Failed Main dispenser switch (failed open).	Disconnect power. Remove both leads from the switch and measure resistance across switch terminals. Resistance should read less than 1 Ω in this position and higher than 10 M Ω when switch is open.	Replace switch.
	Failed Fountain display board or MPCB	With unit powered, close main dispenser switch and press cubed pad. Measure 12 VDC between pin-1 (BK/GN) to pin-4 (LT/BU) on Fountain Display Board.	No 12 VDC, replace Fountain Display Board. 12 VDC present, check for 120 VAC on J1 pin-2 (OR/YL) on MPCB. No 120 VAC, replace MPCB.
	Failed auger motor or PCB.	With unit powered, press the Main dispenser switch. Measure voltage on J1 pin-2 (OR/YL). Voltage should read 120 VAC.	Replace auger motor if voltage reads 120VAC. If no 120 VAC, replace MPCB.
Cubed ice starts to dispense as soon as Cubed mode is selected without pressing the Main dispenser switch.	Failed Main dispenser switch (failed short).	Disconnect power. Remove both leads from the switch and measure resistance across switch terminals. Resistance should read higher than 10 M Ω when switch is open and less than 1 Ω when switch is closed.	Replace switch.
	Failed Fountain Display Board.	With unit powered, measure voltage on pin-1 (BK/GN) to pin-4 (LT/BU) on Fountain Display Board. Voltage should read 0 VDC.	If 12 VDC present replace Fountain Display Board. If 0 VDC present, replace MPCB.
Dispenser operates continuously even when Dispenser Lock mode is activated.	Failed Fountain Display Board.	With unit powered, measure voltage on pin-1 (BK/GN) to pin-4 (LT/BU) on Fountain Display Board. Voltage should read 0 VDC.	12 VDC present, replace Fountain Display Board. If 0 VDC present, replace MPCB.

Troubleshooting Chart



Symptom	Possible Cause	Test Procedure	Corrective Action
Auto Light mode does not operate.	Failed MPCB.	With unit powered and Auto Light activated, cover the light sensor. Measure voltage on VT/BK of 6-pin door connector to WH on 2-pin door connector. Voltage should read 1/2 the AC power supply (120 VAC).	Incorrect voltage, replace MPCB.
Ice or Water dispenser mechanism runs continuously.	Failed Main dispenser switch (failed short).	Disconnect power. Remove both leads from the switch and measure resistance across switch terminals. Resistance should read higher than 10 MΩ when switch is open and less than 1 Ω when switch is closed.	Replace switch.
	Failed MPCB.	With unit powered, measure voltage on pin 1, 2, or 3 of J1. Voltage should read 0 VAC.	Voltage present, replace MPCB.
Filter Status LED never changes to red.	Failed PCB.	Verify with the user if unit has been unplugged for a long period. Demonstrate reset operation to customer.	Replace water filter and reset Filter Status. Replace MPCB if problem continues. Customer education.
Auger motor operates in Cubed or Crushed mode but ice door chute never opens.	Failed solenoid.	Disconnect power. Remove both leads from the solenoid and measure the resistance across solenoid terminals. Resistance should read $101.2 \pm 10\%$.	Replace solenoid.
	Failed MPCB.	With unit powered and auger motor operating, measure approximately 55 VAC on pin-4 of J1 on MPCB.	No 55 VAC, replace MPCB.
Auger motor operates in Cubed or Crushed mode but ice door chute never closes.	Failed MPCB.	Measure voltage on pin-4 of J1 on MPCB. Voltage should read approximately 55 VDC when ice chute door is open (solenoid energized) or 0 VDC when closed (solenoid not energized).	Incorrect voltage, replace MPCB.
No LED lit, Water dispenser operates, auger motor operates only in Cubed mode and ice chute door does not open or remains open.	Failed MPCB.		Replace MPCB
No LED lit, Water dispenser operates, auger motor operates only in Cubed mode and dispenser light is on continuously.	Failed MPCB.		Replace MPCB.

Symptom	Possible Cause	Test Procedure	Corrective Action
Water, Crushed, or Cubed LED will not illuminate but Water, Crushed, or Cubed mode operates properly when selected.	Failed MPCB.		Replace MPCB.
Crushed LED is illuminated but does not dispense crushed ice when Main dispenser switch is pressed.	Failed Main dispenser switch (failed open).	Disconnect power. Remove both leads from the switch and measure resistance across switch terminals. Resistance should read less than 1 Ω in this position and higher than 10 M Ω when switch is open.	Replace switch.
	Failed Fountain display board or MPCB	With unit powered, close main dispenser switch and press crushed ice pad. Measure 12 VDC between pin-1 (BK/GN) to pin-4 (LT/BU) on Fountain Display Board.	No 12 VDC, replace Fountain Display Board. 12 VDC present, check for 120 VAC on J1 pin-3 (BU/WH) on MPCB. No 120 VAC, replace MPCB.
	Failed auger motor or MPCB.	With unit powered, press the Main dispenser switch. Measure voltage on J1 pin-3 (BU/WH) on MPCB. Voltage should read 120 VAC.	Replace auger motor if voltage reads 120VAC. If not, replace MPCB.
Crushed ice starts to dispense as soon as Crushed mode is selected without pressing the Main dispenser switch.	Failed Main dispenser switch (failed short).	Disconnect power. Remove both leads from the switch and measure resistance across switch terminals. Resistance should read less than 1 Ω in this position and higher than 10 M Ω when switch is open.	Replace switch.
	Failed MPCB.	With unit powered, measure voltage on J1 pin-3 (BU/WH) on MPCB. Voltage should read 0 VAC.	120 VAC present, replace MPCB.
Cavity frosted or iced	Failed cavity heater	Disconnect power. Disconnect and measure resistance of heater on door 2-pin connector of approximately 13 K ohms.	13 K ohms present, connect 2-pin connector. With unit powered, measure 120 VAC on 2-pin door connector. No 120 VAC, correct wiring.

Seconds to dispense 10 oz. water

Supply pressure	35 psig	45 psig	55 psig	75 psig
Filter model Bypass installed	9.0	8.0	7.0	6.0
Filter model New filter installed	11.0	10.0	8.0	7.0

A minimum supply pressure of 35 psig for water filter units is required. Minimum pressure requirement ensures that water valves close and sufficient water volume is available to fill icemaker. Proper fill is 140 cc. of water in 7.5 seconds. Failure of water valves to close because of low pressure will result in fill-tube freeze-up or dripping at cavity.

Pin	Color	Signal
1	BK/GN	Digital Gnd
2	WHT/OR	Therm Gnd
3		Therm Amb
4	WH/YL	Therm FZ
5	WH/BU	Therm FF
6	YL/BK	OWL
7		DC+
8	WH/BK	Super Cool DC -
9	RD/BK	+12V
10	LT BU	Disp

Harness MPCB J4 10-pin Connector Configuration

Pin	Color	Signal
1	WH	Neutral L2
2		
3	BU/RD	DWP? CLS NO TR2
4	YL/RD	DWP? OP? NC TR1
5	VT/BK	FTN LITE TR3
6	OR/BK	EV FAN
7	BR	T-STAT RY2
8	BU	COMP RY 1
9	RD	HOT L1

Harness MPCB J3 9-pin Connector Configuration

Pin	Color	Signal
1	YL/WH	DISP VALVE ?Y3
2	OR/YL	Cubed RY4
3	BU/WH	Crushed RY5
4	GY/WH	Ice Door Sol RY?

Harness MPCB J1 4-pin Connector Configuration

Pin	Color	Signal
1	BK/GN	Gnd
2	YL/BK	OWL
3	RD/BK	+12 V
4	LT BU	Disp

Harness Fountain Display J1 4-pin Connector Configuration

Pin	Color	Signal
1	BK	Disp Switch
2	BU	Disp Switch

Harness Fountain Display J2 2-pin Connector Configuration

NOTE: All voltage measurements are referenced to line neutral or pin 1 (WH wire) of MPCB 9-pin connector.

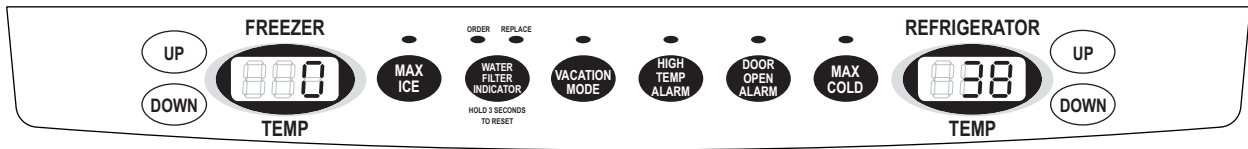

Programming Mode

The Program Code is located on the serial plate on this unit after the word code.

1. Press and hold the DOOR OPEN ALARM button.
2. Press and hold the FREEZER TEMP DOWN button.
3. Release the DOOR OPEN ALARM button and wait 3 seconds.
4. The control will display "PE" to indicate the programming mode.
5. Entry is confirmed by pressing the FREEZER TEMP DOWN button once more.
6. The control will display the current program code. This value should be validated with the program code printed on the unit serial plate.

NOTE: If the program code is correct, the programming mode is exited by closing the refrigerator door.

7. Press the REFRIGERATOR TEMP UP button or REFRIGERATOR TEMP DOWN button to change the digit value with each press.
8. The decimal point indicates the selected digit. Press the FREEZER TEMP UP button to select the next digit.
9. Once the desired program code is entered, press and hold the FREEZER TEMP DOWN button until the program code begins flashing indicating it has been saved.

NOTE: If you attempt to enter an invalid program code the control will not save the new code, but will beep. (The unit will NOT run with a program of 0000). Once the Program has been saved the Programming Mode is exited by closing the refrigerator door). If the new code is incorrect this process should be repeated after closing the refrigerator door.

The Programming Mode can be exited at any time by closing the refrigerator door or will exit if unattended for four minutes.

Defrost Operation

The Control Board adapts the compressor run time between defrosts to achieve optimum defrost intervals by monitoring the length of time the defrost heater is on. After initial power up, defrost interval is 4 hours compressor run time. Defrost occurs immediately after the 4 hours.

Forced Defrost Mode

The Forced Defrost function is performed using the FREEZER TEMP display and REFRIGERATOR TEMP buttons. Enter the Forced Defrost Mode by performing the following sequence of events:

1. Press and hold the DOOR OPEN ALARM button.
2. Press and hold the REFRIGERATOR TEMP DOWN button.
3. Release the DOOR OPEN ALARM button and wait 3 seconds. "Fd" appears in left display.
4. Press the REFRIGERATOR TEMP DOWN button again. "Sh" appears in right display.
5. Press the REFRIGERATOR TEMP DOWN button again to force defrost. "Fd" and "Sh" will flash in display indicating unit is in defrost.

Service Test Mode

Enter the Service Test Mode by performing the following sequence of events.

1. Press and hold the DOOR OPEN ALARM button.
2. Press and hold the REFRIGERATOR TEMP UP button.
3. Release the DOOR OPEN ALARM button and wait 3 seconds. "SE" appears in left display.
4. Press the REFRIGERATOR TEMP UP button again.
5. Display will show "001" in left display and numeric or dashes in right display. This test is for factory use only.
6. Press FREEZER TEMP UP button or FREEZER TEMP DOWN button to toggle through Service Test numbers.

Service Test – 101 Defrost Heater & Defrost Circuit

Press the REFRIGERATOR TEMP UP button and REFRIGERATOR TEMP DOWN button to energize or de-energize the defrost circuit. The display will read “OFF” when de-energized “OP” when energized with open defrost thermostat and “CL” when energized with closed defrost thermostat.

Service Test – 102 Compressor / Condenser Fan

Press the REFRIGERATOR TEMP UP button and REFRIGERATOR TEMP DOWN button to toggle Compressor/Condenser fan “On” and “OFF”.

Service Test – 112 Freezer Fan

Press the REFRIGERATOR TEMP UP button and REFRIGERATOR TEMP DOWN button to toggle Freezer Fan On and Off.

NOTE: Display will show DC voltage.

Service Test – 121 Damper Operation

Press the REFRIGERATOR TEMP UP button and REFRIGERATOR TEMP DOWN button to toggle damper “OP” open and “CL” closed.

NOTE: If damper is opening or closing it will not allow you to toggle damper and beep. Display will show state “-CL” or “-OP” if Damper is in the process of closing or opening.

Service Test – 141 Refrigerator Thermistor

Will show refrigerator temperature or “OP” for open thermistor or “SH” for shorted thermistor.

Service Test – 142 Freezer Thermistor

Will show freezer temperature or “OP” for open thermistor or “SH” for shorted thermistor.

Service Test – 143 Machine Compartment Thermistor

Will show machine compartment temperature or “OP” open thermistor or “SH” shorted thermistor.

Service Test – 151 Refrigerator Door State

Will show state of refrigerator door. “OP” (open) “CL” (closed).

NOTE: By pushing refrigerator door switch you can toggle state from “OP” (open) to “CL” (closed).

Service Test – 152 Freezer Door State

Will show state of freezer door. “OP” (open) “CL” (closed).

NOTE: By pushing freezer door switch you can toggle state from “OP” (open) to “CL” (closed).

Service Test – 161 Cube Dispenser (if equipped)

Display shows the state of the cube dispenser (“On” or “OFF”).

NOTE: By pushing actuator pad you can control state of cube dispenser without opening ice chute door.

Service Test – 162 Crusher Dispenser (if equipped)

Display shows the state of the crusher dispenser (“On” or “OFF”).

NOTE: By pushing actuator pad you can control state of crusher dispenser without opening ice chute door.

Service Test – 163 Water Dispenser (if equipped)

Display shows the state of the water dispenser (“On” or “OFF”).

NOTE: By pushing actuator pad you can control state of water dispenser.

Service Test – 164 Ice Chute Dispenser (if equipped)

Display shows the state of the ice chute dispenser “OP” open or “CL” closed.

NOTE: By pushing actuator pad you can control state of ice chute dispenser.

Service Test – 165 Dispenser Lamp (if equipped)

Display shows the state of the dispenser lamp (“On” or “OFF”).

NOTE: By pushing actuator pad you can control state of dispenser lamp.

Service Test – 171 Actuator Pad (if equipped)

Display shows the state of the actuator pad (“On” or “OFF”).

Service Test – 173 Ambient Light (if equipped)

Display shows light sensor measurement (“Hi” or “Lo”). Night light will turn on when light sensor measures “Lo”. Hold finger over light sensor to change measurement.

Service Test – 175 Dispenser Line (if equipped)

Display shows the state of the dispenser line (“On” or “OFF”).

NOTE: By pushing actuator pad you can change state of dispenser line.

Service Test – 181 Keypad Operation

Display shows a numeric or letter display indicating the last key pressed.

NOTE: REFRIGERATOR TEMP UP/DOWN buttons have no effect when pressed and FREEZER TEMP UP/DOWN buttons remain operational.

Service Test – 182 LED Indicator Operation

Press the REFRIGERATOR TEMP UP button to show operation of LED Indicators. All LED Indicators will flash. Press REFRIGERATOR TEMP DOWN and LED will stop flashing.

Service Test – 191 Ice Maker Water Valve

Display shows the state of the ice maker water valve (“On” or “OFF”).

Service Test – 202 Defrost Operation

Press the REFRIGERATOR TEMP UP button and REFRIGERATOR TEMP DOWN button to toggle defrost operation to minimum time between defrosts on and off.

Service Test – 203 Show Temperature Set Points

Press the REFRIGERATOR TEMP UP button and REFRIGERATOR TEMP DOWN button to toggle display showing actual temperatures (“OFF” position) or showing temperature set points (“On” position).

Service Test – 211 Refrigerator Temperature Adjustment

Press the REFRIGERATOR TEMP UP button and REFRIGERATOR TEMP DOWN button to adjust temperature set points “+6” to “-6”.

Service Test – 212 Freezer Temperature Adjustment

Press the REFRIGERATOR TEMP UP button and REFRIGERATOR TEMP DOWN button to adjust temperature set points “+6” to “-6”.

Service Test – 221 Default Settings Reset

Press the REFRIGERATOR TEMP UP button to force to “dEF” (default factory settings).

Fahrenheit or Celsius Mode

Enter the Fahrenheit or Celsius Mode by performing the following sequence of events:

1. Press and hold the DOOR OPEN ALARM button for 6 seconds.
2. Press FREEZER TEMP UP button until “F_C” is in the freezer display.
3. Press the REFRIGERATOR TEMP UP button or DOWN button to toggle between “°F” and “°C” in the refrigerator display.

Show Room Mode

Enter or exit the Show Room Mode by performing the following sequence of events:

1. Press and hold the DOOR OPEN ALARM button.
2. Press and hold FREEZER TEMP UP button.
3. Release the DOOR OPEN ALARM button and wait 3 seconds. “SH” appears in left display.
4. Press the FREEZER TEMP UP button again. “On” or “OFF” appears in right display.
5. Press the REFRIGERATOR TEMP UP button and REFRIGERATOR TEMP DOWN button to toggle showroom feature “On” or “OFF”.

NOTE: Showroom will always be off when first powered up.

6. Press the FREEZER TEMP UP button to confirm setting. The display will flash the selected setting.

Sabbath Mode

Enter the Sabbath Mode by performing the following sequence of events:

1. Press and hold the DOOR OPEN ALARM button for 6 seconds.
2. Press FREEZER TEMP UP button until “SAB” is in the freezer display.
3. Press the REFRIGERATOR TEMP UP button or DOWN button to toggle between “On” and “OFF” in the refrigerator display.
4. Selection activates immediately.

Alarm Enable Mode

Enter the Alarm Enable Mode by performing the following sequence of events:

1. Press and hold the DOOR OPEN ALARM button for 6 seconds.
2. Press FREEZER TEMP UP button until “AL” is in the freezer display.
3. Press the REFRIGERATOR TEMP UP button or DOWN button to toggle between “On” and “OFF” in the refrigerator display.
4. Close door or toggle door switch to activate.

Light Level Mode (Select Models)

Enter the Light Level Mode by performing the following sequence of events:

1. Press and hold the DOOR OPEN ALARM button for 6 seconds.
2. Press FREEZER TEMP UP button until “LL” is in the freezer display.
3. Press the REFRIGERATOR TEMP UP button or DOWN button to raise or lower light level at the dispenser from “1” (darkest light level setting) to “9” (lightest light level setting) in the refrigerator display.
4. Close door or toggle door switch to activate.

Component	Description	Test Procedures
Capacitor	<p>Run capacitor connects to relay terminal 3 and L side of line.</p> <p>Some compressors do not require a run capacitor; refer to the Technical Data Sheet for the unit being serviced.</p>	<div style="border: 1px solid black; padding: 5px; margin-bottom: 10px;"> WARNING </div> <p>To avoid electrical shock which can cause severe personal injury or death, discharge capacitor through a resistor before handling.</p> <ol style="list-style-type: none"> 1. Disconnect power to refrigerator. 2. Remove capacitor cover and disconnect capacitor wires. 3. Discharge capacitor by shorting across terminals with a resistor for 1 minute. 4. Check resistance across capacitor terminals with ohmmeter set on "X1K" scale. <ul style="list-style-type: none"> • Good – needle swings to 0 ohms and slowly moves back to infinity. • Open – needle does not move. Replace capacitor. • Shorted – needle moves to zero and stays. Replace capacitor. • High resistance leak – needle jumps toward 0 and then moves back to constant high resistance (not infinity).
Compressor	<p>When compressor electrical circuit is energized, the start winding current causes relay to heat. After an amount of starting time, the start winding circuit turns off. The relay will switch off the start winding circuit even though compressor has not started (for example, when attempting to restart after momentary power interruption).</p> <p>With "open" relay, compressor will not start because there is little or no current to start windings. Overload protection will open due to high locked rotor run winding current.</p> <p>With "shorted" relay or capacitor, compressor will start and overload protector will quickly open due to high current of combined run and start windings.</p> <p>With open or weak capacitor, compressor will start and run as normal but will consume more energy.</p>	<p>Resistance test</p> <ol style="list-style-type: none"> 1. Disconnect power to unit. 2. Discharge capacitor by shorting across terminals with a resistor for 1 minute. <p>NOTE: Some compressors do not have a run capacitor.</p> <ol style="list-style-type: none"> 3. Remove leads from compressor terminals. 4. Set ohmmeter to lowest scale. 5. Check for resistance between <ul style="list-style-type: none"> • Terminals "S" and "C", start winding • Terminals "R" and "C", run winding If either compressor winding reads open (infinite or very high resistance) or dead short (0 ohms), replace compressor. <p>Ground test</p> <ol style="list-style-type: none"> 1. Disconnect power to refrigerator. 2. Discharge capacitor, if present, by shorting terminals through a resistor. 3. Remove compressor leads and use an ohmmeter set on highest scale. 4. Touch one lead to compressor body (clean point of contact) and other probe to each compressor terminal. <p>NOTE: If reading is obtained, compressor is grounded and must be replaced.</p>

Component	Description	Test Procedures
Compressor		<p>Operation test</p> <p>If voltage, capacitor, overload, and motor winding tests do not show cause for failure, perform the following test:</p> <ol style="list-style-type: none"> 1. Disconnect power to refrigerator. 2. Discharge capacitor by shorting capacitor terminals through a resistor. 3. Remove leads from compressor terminals. 4. Wire a test cord to power switch. 5. Place time delayed fuse with UL rating equal to amp rating of motor in test cord socket. (Refer to Technical Data Sheet.) 6. Remove overload and relay. 7. Connect start, common and run leads of test cord on appropriate terminals of compressor. 8. Attach capacitor leads of test cord together. If capacitor is used, attach capacitor lead to a known good capacitor of same capacity. <div style="text-align: center;"> <p>The diagram illustrates the test setup. At the top, an arrow points to 'To AC Supply'. Below it is a switch. Two wires from the switch pass through fuses. One wire goes to the 'C' terminal of the compressor, and the other goes to the 'S' terminal. The 'R' terminal is connected to the 'C' terminal. A capacitor is connected between the 'S' and 'R' terminals.</p> </div> <ol style="list-style-type: none"> 9. Plug test cord into multimeter to determine start and run wattage and to check for low voltage, which can also be a source of trouble indications. 10. With power to multimeter, press start cord switch and release. <ul style="list-style-type: none"> • If compressor motor starts and draws normal wattage, compressor is okay and trouble is in capacitor, relay/overload, freezer temperature control, or elsewhere in system. • If compressor does not start when direct wired, recover refrigerant at high side. After refrigerant is recovered, repeat compressor direct wire test. If compressor runs after recovery but would not run when direct wired before recover, a restriction in sealed system is indicated. • If compressor does not run when wired direct after recovery, replace faulty compressor.

Component	Description	Test Procedures
<p>Condenser</p>	<p>Condenser is a tube and wire construction located in machine compartment.</p> <p>Condenser is on high pressure discharge side of compressor. Condenser function is to transfer heat absorbed by refrigerant to ambient.</p> <p>Higher pressure gas is routed to condenser where gas condenses into a high pressure liquid state. Heat transfer takes place because discharged gas is at a higher temperature than air that is passing over condenser. Adequate air flow over condenser must be maintained.</p> <p>Condenser is air cooled by condenser fan motor. If efficiency of heat transfer from condenser to surrounding air is impaired, condensing temperature becomes higher. High liquid temperature means liquid will not remove as much heat during boiling in evaporator as under normal conditions. This would be indicated by higher than normal head pressures, long run time, and high wattage. Remove any obstruction that would restrict normal air movement through condenser.</p> <p>From condenser the refrigerant flows into a post condenser loop which helps control exterior condensation on flange, center mullion, and around freezer door. Refrigerant then flows through the drier to evaporator and into compressor through suction line</p>	<p>Leaks in condenser can usually be detected by using an electronic leak detector or soap solution. Look for signs of compressor oil when checking for leaks. A certain amount of compressor oil is circulated with refrigerant.</p> <p>Leaks in post condenser loop are rare because loop is a one-piece copper tube.</p> <p>For minute leaks</p> <ol style="list-style-type: none"> 1. Separate condenser from rest of refrigeration system and pressurize condenser up to a maximum of 235 PSI with a refrigerant and dry nitrogen combination. 2. Recheck for leaks. <div style="border: 1px solid black; padding: 5px; margin: 10px 0;"> <p style="text-align: center;"> WARNING</p> <p>To avoid severe personal injury or death from sudden eruption of high pressures gases, observe the following: Protect against a sudden eruption if high pressures are required for leak checking. Do not use high pressure compressed gases in refrigeration systems without a reliable pressure regulator and pressure relief valve in the lines.</p> </div>
<p>Overload/Relay</p>	<p>When voltage is connected and relay is cool, current passes through relay to start winding.</p> <p>After a short time, current heats the resistor in relay and resistance will rise blocking current flow through relay.</p> <p>Start winding remains in the circuit through run capacitor.</p> <p>Solid state relay plugs directly on compressor start and run terminals. Relay terminals 2 and 3 are connected within relay. Run capacitor is connected to relay.</p>	<ol style="list-style-type: none"> 1. Disconnect power to the refrigerator. 2. Remove relay cover and disconnect leads. 3. Check resistance across terminals 2 and 3 with an ohmmeter: <ul style="list-style-type: none"> • Normal = 3 to 12 ohms • Shorted = 0 ohms • Open = infinite ohms

Component	Description	Test Procedures
Control board	See Control Board section for troubleshooting information.	
Ice Maker	See Ice Maker section for service information.	
ECM condenser motor	Condenser fan moves cooling air across condenser coil and compressor body. Condenser fan motor is in parallel circuit with compressor.	Check resistance across motor. If no resistance across motor, replace motor.
Evaporator fan motor	Evaporator fan moves air across evaporator coil and throughout refrigerator cabinet.	<ol style="list-style-type: none"> 1. Disconnect power to unit. 2. Disconnect fan motor leads. 3. Check resistance from ground connection solder. Trace to motor frame must not exceed .05 ohms. 4. Check for voltage at connector to motor with unit in refrigeration mode and compressor operating.
Refrigerator light switch	Single pole, single throw switch completes circuit for light when door is open.	Check resistant across terminals. Switch arm depressed <ul style="list-style-type: none"> • "NO" terminals Open Switch arm up <ul style="list-style-type: none"> • "NO" terminals Closed
Freezer light/ Interlock switch	Single pole, Double throw switch completes circuit for light when door is open. Completes circuit for dispenser when door is closed.	Check resistant across terminals. Switch arm depressed <ul style="list-style-type: none"> • "NO" terminals Open • "NC" terminals Closed Switch arm not depressed <ul style="list-style-type: none"> • "NC" terminals Open • "NO" terminals Closed
Water valve	Controls water flow to the ice maker. Controlled by thermostat in ice maker. See Ice Maker section for further information.	Check resistance across coil windings.
Defrost timer	Timer motor operates only when freezer control is closed. After specified amount of actual operating time, inner cam in timer throws the contacts from terminal 4, compressor circuit, to terminal 2, defrost thermostat/defrost heater circuit. After specified defrost cycle time, timer cam resets the circuitry through terminal 4 to compressor.	<ol style="list-style-type: none"> 1. To check timer motor winding, check for continuity between terminals 1 and 3 of timer. 2. Depending on rotating position of the cam, terminal 1 of timer is common to both terminal 2, the defrost mode, and terminal 4, the compressor mode. There should never be continuity between terminals 2 and 4. 3. With continuity between terminals 1 and 4, rotate timer knob clockwise until audible click is heard. When the click is heard, reading between terminals 1 and 4 should be infinite and there should be continuity between terminals 1 and 2. 4. Continuing to rotate time knob until a second click is heard should restore circuit between terminals 1 and 4.

Component	Description	Test Procedures
Drier	<p>Drier is placed at post condenser loop outlet and passes liquefied refrigerant to capillary.</p> <p>Desiccant (20) 8 x 12 4AXH - 7 M>S> - Grams</p>	<p>Drier must be changed every time the system is opened for testing or compressor replacement.</p> <p>NOTE: Drier used in R12 sealed system is not interchangeable with drier used in R134a sealed system. Always replace drier in R134a system with correct part number.</p> <p>Before opening refrigeration system, recover HFC134a refrigerant for safe disposal.</p> <ol style="list-style-type: none"> 1. Cut drier out of system using the following procedure. Do not unbraid drier. 2. Applying heat to remove drier will drive moisture into the system. 3. Score capillary tube close to drier and break. 4. Reform inlet tube to drier allowing enough space for large tube cutter. 5. Cut circumference of drier 1 ¼" below condenser inlet tube joint to drier. 6. Remove drier. 7. Apply heat trap paste on post condenser tubes to protect grommets from high heat. 8. Unbraid remaining part of drier. Remove drier from system. 9. Discard drier in safe place. Do not leave drier with customer. If refrigerator is under warranty, old drier must accompany warranty claim. <div style="border: 1px solid black; padding: 5px; margin-top: 10px;"> <p style="text-align: center;"> WARNING</p> <p>To avoid death or severe personal injury, cut drier at correct location. Cutting drier at incorrect location will allow desiccant beads to scatter. If spilled, completely clean area of beads.</p> </div>
Evaporator defrost heater	<p>Activated when defrost thermostat, defrost timer, and freezer control complete circuit through heater.</p>	<p>To check defrost system :</p> <ol style="list-style-type: none"> 1. Thermocouple defrost thermostat and plug refrigerator into wattmeter. 2. Turn into defrost mode. Wattmeter should read specified watts (according to Technical Data Sheet). 3. When defrost thermostat reaches specified temperature $\pm 5^{\circ}\text{F}$ (see Technical Data Sheet), thermostat should interrupt power to heater.
Thermostat	<p>Thermostat is in a series circuit with terminal 2 of defrost timer, and defrost heater. Circuit complete if evaporator fan motor operates when cold.</p> <p>Controls the circuit from freezer thermostat through defrost terminator to defrost heater. Opens and breaks circuit when thermostat senses preset high temperature.</p>	<p>Test continuity across terminals.</p> <p>With power off and evaporator coil below freezing, thermostat should show continuity when checked with ohmmeter. See Heater, evaporator (defrost) section for additional tests.</p> <p>After defrost thermostat opens, thermostat remains open until end of defrost cycle and refrigerator starts cooling again. Defrost thermostat senses a preset low temperature and resets (closes).</p>

Component	Description	Test Procedures								
Evaporator	<p>Inner volume of evaporator allows liquid refrigerant discharged from capillary to expand into refrigerant gas.</p> <p>Expansion cools evaporator tube and fin temperature to approximately -20°F transferring heat from freezer section to refrigerant.</p> <p>Passing through suction line to compressor, the refrigerant picks up superheat (a relationship between pressure and temperature that assures complete vaporization of liquid refrigerant) as the result of capillary tube soldered to suction line.</p> <p>Refrigerant gas is pulled through suction line by compressor, completing refrigeration cycle.</p>	<p>Test for leaks in evaporator with electronic leak detector or with soap solution. Compressor oil is circulated with refrigerant; check for oil when checking for leaks.</p> <p>For minute leaks</p> <ol style="list-style-type: none"> 1. Separate evaporator from rest of refrigeration system and pressurize evaporator up to a maximum of 140 PSI with a refrigerant and dry nitrogen combination. 2. Recheck for leaks. <div style="border: 2px solid black; padding: 5px; text-align: center; background-color: #f4a460;">  WARNING </div> <p>To avoid severe personal injury or death from sudden eruptions of high pressure gases, observe the following:</p> <ul style="list-style-type: none"> • Protect against a sudden eruption if high pressures are required for leak checking. • Do not use high pressure compressed gases in refrigeration systems without a reliable pressure regulator and pressure relief valve in the lines. 								
Thermistor	Temperature sensing device	<p>Check resistance across leads.</p> <table border="0" style="margin-left: 40px;"> <thead> <tr> <th style="text-align: left;">Temperature</th> <th style="text-align: left;">Resistance</th> </tr> </thead> <tbody> <tr> <td>77°F</td> <td>10,000 ohms</td> </tr> <tr> <td>36°F</td> <td>29,500 ohms</td> </tr> <tr> <td>0°F</td> <td>86,300 ohms</td> </tr> </tbody> </table>	Temperature	Resistance	77°F	10,000 ohms	36°F	29,500 ohms	0°F	86,300 ohms
Temperature	Resistance									
77°F	10,000 ohms									
36°F	29,500 ohms									
0°F	86,300 ohms									
Electric damper control	<p>Damper control balances the air delivery between refrigerator and freezer compartments providing temperature control for refrigerator.</p> <p>Electrical voltage activates damper control and door closes restricting flow of air from freezer compartment to refrigerator compartment.</p>	<p>Check resistance across terminals.</p> <p>If no resistance across terminals replace damper control.</p>								

CONDITION	SUCTION PRESSURE VARIATION FROM NORMAL	HEAD PRESSURE VARIATION FROM NORMAL	T1 INLET TEMPERATURE VARIATION FROM NORMAL	T2 OUTLET TEMPERATURE VARIATION FROM NORMAL	T3 SUCTION TEMPERATURE VARIATION FROM NORMAL	WATTAGE VARIATION FROM NORMAL
Refrigerant Overcharge	Increase	Increase	Warmer	Warmer	Colder	Increase
Shortage of Refrigerant	Decrease	Decrease or Increase See Text	Colder	Warmer	Warmer	Decrease
Partial Restriction	Decrease	Decrease or Increase See Text	Colder	Warmer	Warmer	Decrease
Air in System	Near Normal	Increase	Warmer	Warmer	Warmer	Increase
Low Ambient Installations (High Ambients the Reverse)	Decrease	Decrease	Colder	Warmer	Warmer	Decrease
Additional Heat Load	Increase	Increase	Warmer	Warmer	Warmer	Increase
Inefficient Compressor	Increase	Normal or Decrease	Warmer or Colder	Warmer	Warmer	Decrease

Symptoms of an Overcharge

Above normal freezer temperatures.
 Longer than normal or continuous run.
 Freezing in refrigerator, especially on forced air meatkeeper models.
 Higher than normal suction and head pressure.
 Higher than normal wattage.
 Evaporator inlet and outlet temperatures warmer than normal.
 Suction tube temperature below ambient. Always check for separated heat exchanger when suction temperature is colder than ambient.

Various conditions could indicate an overcharge. For example, if the cooling coil is not defrosted at regular intervals, due to a failure of the defrost system, the refrigerant will "flood out" and cause the suction line to frost or sweat. The cause of this problem should be corrected rather than to purge refrigerant from the system. Running the freezer section colder than necessary (-2 to -1°F is considered normal package temperatures) or continuous running of the compressor for a variety of reasons, or the freezer fan motor not running, may give the indication of an overcharge.

Symptoms of Air in System

This can result from a low side leak or improper servicing. If a leak should occur on the low side, the temperature control would not be satisfied; thus, continuous running of the compressor would result. The compressor would eventually pump the low side into a vacuum drawing air and moisture into the system. Air and R134A do not mix so the air pressure would be added to the normal head pressure, resulting in higher than normal head pressures.

One way to determine if air is in the system is to read the head pressure gauge with the product off and evaporator and condenser at the same temperature and then take the temperature on the condenser outlet tube. This temperature should be within 3° or 4°F of what the Pressure-Temperature Relation chart shows for the given idle head pressure. If the temperature of the condenser outlet is considerably lower than the idle head pressure of the gauge this would indicate there is air in the system.

Thorough leak checking is necessary. Correct the source of the leak. Do not attempt to purge off the air because this could result in the system being undercharged. It is best to discharge, replace drier, evacuate and recharge with the specified refrigerant charge.

Symptoms of Refrigeration Shortage

Rise in food product temperature in both compartments.
(See Note below.)

Long or continuous run time.

Look for obvious traces of oil that would occur due to a leak or cracked refrigerant line.

Lower than normal wattage.

Compressor will be hot to touch because of the heat generated by the motor windings from long continuous running. It will not be as hot as it would be with a full charge and long run times for some other reason such as a dirty condenser.

Depending on the amount of the shortage, the condenser will not be hot, but closer to room temperature. The capillary tube will be warmer than normal from a slight shortage.

If the leak is on the high side of the system, both gauges will show lower than normal readings and will show progressively lower readings as this charge becomes less. The suction pressure gauge will probably indicate a vacuum.

If the leak is on the low side of the system the suction pressure gauge will be lower than normal, probably in a vacuum, and the head pressure gauge will be higher than normal. It will probably continue to become higher because air drawn in through the leak is compressed by the compressor and accumulates in the high side (condenser) of the system.

Only partial frosting of evaporator instead of even frosting of entire coil.

NOTE: Usually the first thing that is noticed by the user is a rise in temperature foods. Although temperatures will rise in both the freezer section and the food compartment, the frozen meats and vegetables will not thaw immediately. The customer doesn't associate the problem with the freezer section and will first notice that milk and other food beverages are not cold enough.

Under some circumstances, such as in the case of forced air meatkeeper model with a slight shortage of refrigerant, freezing in the food compartment may be experienced due to the additional running time. With a refrigerant leak, however, it always gets worse and as the refrigerant charge decreases the temperature will continue to rise.

With a shortage of refrigerant the capillary line will not have a full column of liquid. As a result, there is a noticeable hissing sound in the evaporator. This should not be mistaken for the regular refrigerant boiling sounds that would be considered normal.

Symptoms of Low or High Ambient Temperature Installation

Lower ambient air temperature reduces the condensing temperature and therefore reduces the temperature of the liquid entering the evaporator. The increase in refrigeration effect due to operation in a lower ambient results in a decrease in power consumption and run time. At lower ambients there is a reduction in cabinet heat leak which is partially responsible for lower power consumption and run time.

An increase in refrigeration effect cannot be expected below a certain minimum ambient temperature. This temperature varies with the type and design of the product.

Generally speaking, ambient temperatures cannot be lower than 60° F. without affecting operating efficiency. Conversely, the higher the ambient temperature the higher the head pressure must be to raise the high side refrigerant temperature above that of the condensing medium. Therefore, head pressure will be higher as the ambient temperature raises. Refrigerators installed in ambient temperatures lower than 60° F. will not perform as well because the pressures within the system are generally reduced and unbalanced. This means that the lower head pressure forces less liquid refrigerant through the capillary line. The result is the symptoms of a refrigerant shortage. The lower the ambient temperature the more pronounced this condition becomes.

When a point where the ambient temperature is below the cut-in of the Temperature Control is reached, the compressor won't run.

The drain traps will freeze in ambient temperatures of 32° F.

Heat Load

A greater heat load can result from the addition of more than normal supply of foods, such as after doing the weekly shopping. Other items contributing to an additional heat load would be excessive door openings, poor door sealing, interior light remaining on, etc.

An increase in heat being absorbed by the refrigerant in the evaporator will affect the temperature and pressure of the gas returning to the compressor. Compartment temperatures, power consumption, discharge, and suction pressures are all affected by heat load. Pressures will be higher than normal under heavy heat load.

Symptoms of a Restriction

Always remember refrigeration (cooling) occurs on the low pressure side of a partial restriction (a total restriction will completely stop the circulation of refrigerant and no cooling will take place).

Physically feel the refrigeration lines when a restriction is suspected. The most common place for a restriction is at the drier-filter or at the capillary tube inlet or outlet. If the restriction is not total there will be a temperature difference at the point of restriction, the area on the evaporator side will be cooler. In many cases frost and/or condensation will be present. A longer time is required for the system to equalize.

Any kinked line will cause a restriction so the entire system should be visually checked.

A slight restriction will give the same indications as a refrigerant shortage with lower than normal back pressure, head pressure, and wattage, warmer product temperatures.

NOTE: If a total restriction is on the discharge side of the compressor, higher than normal head pressures and wattages would result. This is true only while the low side is being pumped out and if the restriction was between the compressor and the first half of the condenser.

To diagnose for a restriction versus a refrigerant shortage, discharge the system, replace the drier-filter, evacuate and recharge with the specified refrigerant charge. If the unit performs normally three possibilities exist: 1) refrigerant loss, 2) partially restricted drier filter, and 3) moisture in system.

If the unit performs as it previously did you may have a restricted capillary line or condenser or kinked line. Find the point of restriction and correct it.

A restriction reduces the flow rate of the refrigerant and consequently reduces the rate of heat removal.

Complete restriction may be caused by moisture, solid contaminants in the system, or a poorly soldered joint. Moisture freezes at the evaporator inlet end of the capillary tube or solid contaminants collect in the drier-filter. The wattage drops because the compressor is not circulating the usual amount of refrigerant.

As far as pressure readings are concerned, if the restriction, such as a kinked line or a joint soldered shut is anywhere on the low side, the suction pressure would probably be in a vacuum while the head pressure will be near normal. If the restriction is on the high side, the suction pressure, again, will probably be in a vacuum while the head pressure will be higher than normal during the pump out period described earlier. In either case, it will take longer than the normal ten minutes or so for the head pressure to equalize with the low side after the compressor stops.

Service Equipment

Listed below is equipment needed for proper servicing of HFC134a systems. Verify equipment is confirmed by manufacturer as being compatible with HFC134a and ester oil system.

Evacuation pump

- Check with vacuum pump supplier to verify equipment is compatible for HFC134a.

Leak detector

Flux

Sil-Fos

Silver solder

Dry nitrogen

- 99.5% minimum purity, with -40°F or lower dew point

Crimp tool

Tube bender

Micron vacuum gauge

Heat trap paste

The following equipment must be exclusively used for HFC134a.

Four-way manifold gauge set, with low loss hoses

Charging cylinder

Line piercing saddle valve

- (Schroeder valves). Seals must be HFC134a and ester oil compatible. Line piercing valves may be used for diagnosis but are not suitable for evacuation or charging, due to minute holes pierced in tubing. Do not leave mechanical access valves on system. Valves eventually will leak. Molecules of HFC134a are smaller than other refrigerants and will leak where other refrigerants would not.

Swagging tools

Flaring tools

Tubing cutter

Oil for swagging and flaring

Copper tubing

Process tube adaptor kit

ICI appliance grade HFC134a

Leak Testing



DANGER

TO AVOID RISK OF SERIOUS INJURY OR DEATH FROM VIOLENT EXPLOSIONS, NEVER USE OXYGEN OR ACETYLENE FOR PRESSURE TESTING OR CLEAN OUT OF REFRIGERATION SYSTEMS. FREE OXYGEN WILL EXPLODE ON CONTACT WITH OIL. ACETYLENE WILL EXPLODE SPONTANEOUSLY WHEN PUT UNDER PRESSURE.

It is important to check sealed system for refrigerant leaks. Undetected leaks can lead to repeated service calls and eventually result in system contamination, restrictions, and premature compressor failure.

Refrigerant leaks are best detected with halide or electronic leak detectors.

Testing Systems Containing a Refrigerant Charge

1. Stop unit operation (turn refrigerator off).
2. Holding leak detector exploring tube as close to system tubing as possible, check all piping, joints, and fittings.

NOTE: Use soap suds on areas leak detector cannot reach or reliably test.

Testing Systems Containing No Refrigerant Charge

1. Connect cylinder of nitrogen, through gauge manifold, to process tube of compressor and liquid line strainer.
2. Open valves on nitrogen cylinder and gauge manifold. Allow pressure to build within sealed system.
3. Check for leaks using soap suds.

If a leak is detected in a joint, do not attempt to repair by applying additional brazing material. Joint must be disassembled, cleaned and rebrazed. Capture refrigerant charge (if system is charged), unbrazed joint, clean all parts, then rebraze.

If leak is detected in tubing, replace tubing. If leak is detected in either coil, replace faulty coil.

Refrigerant Precautions

WARNING

To avoid risk of personal injury, do not allow refrigerant to contact eyes or skin.

CAUTION

To avoid risk of property damage, do not use refrigerant other than that shown on unit serial number identification plate.

NOTE: All precautionary measures recommended by refrigerant manufacturers and suppliers apply and should be observed.

Line Piercing Valves

Line piercing valves can be used for diagnosis, but are not suitable for evacuating or charging due to holes pierced in tubing by valves.

NOTE: Do not leave line piercing valves on system. Connection between valve and tubing is not hermetically sealed. Leaks will occur.

Open Lines

During any processing of refrigeration system, never leave lines open to atmosphere. Open lines allow water vapor to enter system, making proper evacuation more difficult.

Compressor Operational Test

(short term testing only)

If compressor voltage, capacitor, overload, and motor winding tests are successful (do not indicate a fault), perform the following test:

1. Disconnect power to unit.
2. Discharge capacitor by shorting capacitor terminals through a resistor.

NOTE: Not all units have run capacitor.

3. Remove leads from compressor terminals.
4. Attach test cord to compressor windings.
 - Common lead on test cord attaches to C terminal on compressor.
 - Start lead on test cord attaches to S terminal on compressor.
 - Run lead on test cord attaches to M terminal on compressor.

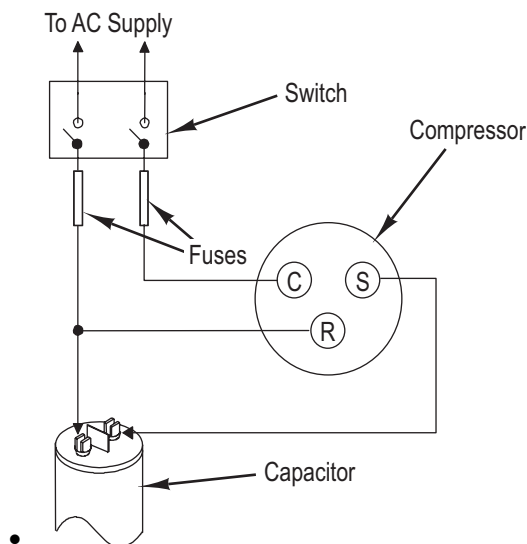

Attaching Capacitor for Compressor Test

5. Connect a known good capacitor into circuit as shown above. For proper capacitor size and rating, refer to Technical Data Sheet for unit under test.

NOTE: Ensure test cord cables and fuses meet specifications for unit under test (refer to Technical Data Sheet for unit under test).

6. Replace compressor protector cover securely.
7. Plug test cord into outlet, then press and release start cord switch.

CAUTION

To avoid risk of damage to compressor windings, immediately disconnect (unplug) test cord from power source if compressor does not start. Damage to compressor windings occurs if windings remain energized when compressor is not running.

If compressor runs when direct wired, it is working properly. Malfunction is elsewhere in system.

If compressor does not start when direct wired, recover system at high side. After the system is recovered, repeat compressor direct wire test.

If compressor runs after system is recovered (but would not operate when wired direct before recovery) a restriction in sealed system is indicated.

If motor does not run when wired direct after recovery, replace faulty compressor.

Dehydrating Sealed Refrigeration System

Moisture in a refrigerator sealed system exposed to heat generated by the compressor and motor reacts chemically with refrigerant and oil in the system and forms corrosive hydrochloric and hydrofluoric acids. These acids contribute to breakdown of motor winding insulation and corrosion of compressor working parts, causing compressor failure.

In addition, sludge, a residue of the chemical reaction, coats all surfaces of sealed system, and will eventually restrict refrigerant flow through capillary tube.

To dehydrate sealed system, evacuate system (see Evacuation).

Restrictions

Symptoms

Restrictions in sealed system most often occur at capillary tube or filter drier, but can exist anywhere on liquid side of system.

Restrictions reduce refrigerant flow rate and heat removal rate. Wattage drops because compressor is not circulating normal amount of refrigerants.

Common causes of total restrictions are moisture, poorly soldered joints, or solid contaminants. Moisture freezes at evaporator inlet end of capillary tube. Solid contaminants collect in filter drier.

If restriction is on low side, suction pressure will be in a vacuum and head pressure will be near normal.

If restriction is on high side, suction pressure will be in a vacuum and head pressure will be higher than normal during pump out cycle.

Refrigeration occurs on low pressure side of partial restriction. There will be a temperature difference at the point of restriction. Frost and/or condensation will be present in most case at the point of restriction. Also, system requires longer to equalize.

Slight or partial restriction can give the same symptoms as refrigerant shortage including lower than normal back pressure, head pressure, wattage, and warmer temperatures.

Total restriction on the discharge side of compressor, when restriction is between compressor and first half of condenser, results in higher than normal head pressure and wattage while low side is being pumped out.

Testing for Restrictions

To determine if a restriction exists:

1. Attach gauge and manifold between suction and discharge sides of sealed system.
 2. Turn unit on and allow pressure on each side to stabilize. Inspect condenser side of system. Tubing on condenser should be warm and temperature should be equal throughout (no sudden drops at any point along tubing).
 - If temperature of condenser tubing is consistent throughout, go to step 4.
 - If temperature of condenser tubing drops suddenly at any point, tubing is restricted at point of temperature drop (if restriction is severe, frost may form at point of restriction and extend down in direction of refrigerant flow in system). Go to step 5.
 3. Visually check system for kinks in refrigeration line which is causing restriction. Correct kink and repeat step 2.
 4. Turn unit off and time how long it takes high and low pressure gauges to equalize:
 - If pressure equalization takes longer than 10 minutes, a restriction exists in the capillary tube or drier filter. Go to step 5.
 - If pressure equalization takes less than 10 minutes, system is not restricted. Check for other possible causes of malfunction.
 5. Recover refrigerant in sealed system.
- NOTE:** Before opening any refrigeration system, capture refrigerant in system for safe disposal.
6. Remove power from unit.



CAUTION

To avoid risk of personal injury or property damage, take necessary precautions against high temperatures required for brazing.

7. Remove and replace restricted device.
8. Evacuate sealed system.
9. Charge system to specification.

NOTE: Do not use captured or recycled refrigerant in units. Captured or recycled refrigerant voids any compressor manufacturer's warranty.

NOTE: Charge system with exact amount of refrigerant. Refer to unit nameplate for correct refrigerant charge. Inaccurately charged system will cause future problems.

Evacuation and Charging

CAUTION

To avoid risk of fire, sealed refrigeration system must be air free. To avoid risk of air contamination, follow evacuation procedures exactly.

NOTE: Before opening any refrigeration system, EPA regulations require refrigerant in system to be captured for safe disposal.

Proper evacuation of sealed refrigeration system is an important service procedure. Usable life and operational efficiency greatly depends upon how completely air, moisture and other non-condensables are evacuated from sealed system.

Air in sealed system causes high condensing temperature and pressure, resulting in increased power requirements and reduced performance.

Moisture in sealed system chemically reacts with refrigerant and oil to form corrosive hydrofluoric and hydrochloric acids. These acids attack motor windings and parts, causing premature breakdown.

Before opening system, evaporator coil must be at ambient temperature to minimize moisture infiltration into system.

Evacuation

To evacuate sealed refrigeration system:

1. Connect vacuum pump, vacuum tight manifold set with high vacuum hoses, thermocouple vacuum gauge and charging cylinder as shown in illustration. Evacuation should be done through I.D. opening of tubes not through line piercing valve.
2. Connect low side line to compressor process tube.
3. Connect high side line to drier/process tube.
4. Evacuate both simultaneously. With valve "C" and "F" closed, open all other valves and start vacuum pump.

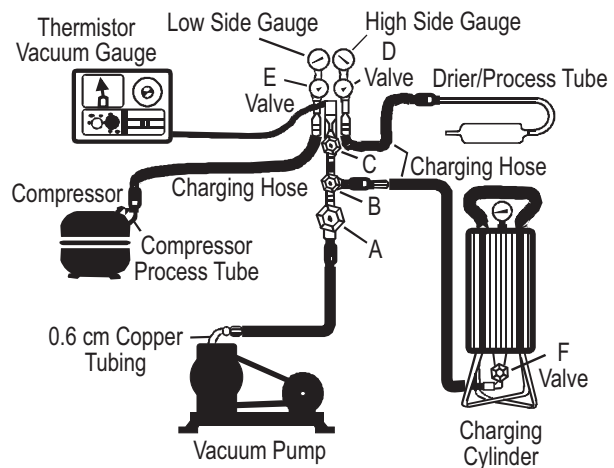

Equipment Setup for Evacuation and Charging

5. After compound gauge (low side) drops to approximately 29 inches gauge, open valve "C" to vacuum thermocouple gauge and take micron reading.

NOTE: A high vacuum pump can only produce a good vacuum if oil in pump is not contaminated.

6. Continue evacuating system until vacuum gauge registers 600 microns.
7. At 600 microns, close valve "A" to vacuum pump and allow micron reading in system to balance. Micron level will rise.
 - If in 2 minutes, micron level stabilizes at 1000 microns or below, system is ready to be charged.
 - If micron level rises above 1000 microns and stabilizes, open valve "A" and continue evacuating.
 - If micron reading rises rapidly and does not stabilize, a leak still exists in system, go to step 8.
8. Close valve "A" to vacuum pump and valve "C" to vacuum gauge. Invert charging cylinder and open charging cylinder valve "F" to add partial charge for leak checking. With leak detector, check manifold connections and system for leaks. After locating leak, capture refrigerant, repair leak, and begin at step 1.

Charging

NOTE: Do not use captured or recycled refrigerant in units. Captured or recycled refrigerant voids any warranty.

NOTE: Charge system with exact amount of refrigerant. Refer to unit serial plate for correct refrigerant charge. Inaccurately charged system will cause future problems.

To charge system:

Close valves "A" to vacuum pump and "C" to vacuum gauge and "E" to low side manifold gauge.

1. Set scale on dial-a-charge cylinder for corresponding HFC134a pressure reading.
2. Open valve "F" to charging cylinder and let exact amount of refrigerant flow from cylinder into system. Close valve.
Low side gauge pressure should rise shortly after opening charging cylinder valve as system pressure equalizes through capillary tube.
If pressure does not equalize, a restriction typically exists at capillary/drier braze joint.
3. If pressure equalizes, open valve "E" to low side manifold gauge and pinch off high side drier process tube.
4. Start compressor and draw remaining refrigerant from charging hoses and manifold into compressor through compressor process tube.
5. To check high side pinch-off drier process tube. Close valve "D" to high side gauge. If high side pressure rises, repeat high side pinch-off and open valve "D". Repeat until high side pinch-off does not leak.
6. Pinch-off compressor process tube and remove charging hose. Braze stub closed while compressor is operating.
7. Disconnect power. Remove charging hose and braze high side drier process tube closed.
8. Recheck for refrigerant leaks.

Refrigerant Charge

Refrigerant charge in all capillary tube systems is critical and exact amount is required for proper performance. Factory charges are shown on serial plate.

NOTE: Do not use refrigerant other than shown on serial plate.

HFC134a Service Information

HFC134a is alternative refrigerant for CFC12.

HFC134a has an ozone depletion potential (ODP) factor of 0.0 and a global warming potential (GWP) factor of 0.27. HFC134a is not flammable and has acceptable toxicity levels. HFC134a is not interchangeable with CFC12. There are significant differences between HFC134a and CFC12 which must be considered when handling and processing refrigeration system.

Health, Safety, and Handling

Health, safety and handling considerations for HFC134A are virtually no different than those for CFC12.

Health, Safety, and Handling	CFC12	HFC134a
Allowable overall exposure limit	1,000 ppm	Same
Vapor exposure to skin	No effect	Same
Liquid exposure to skin	Can cause frostbite	Same
Vapor exposure to eye	Very slight eye irritant	Same
Liquid exposure to eye	Can cause frostbite	Same
Above minimum exposure limit	Can cause Asphyxiation, Tachycardia, and Cardia Arrhythmias	Same
Safety and handling	Wear appropriate skin and eye protection. Use with adequate ventilation.	Same
Spill management	Remove or extinguish ignition or combustion sources. Evacuate or ventilate area.	Same
Fire explosion hazards	May decompose if contact with flames and heating elements. Container may explode if heated due to resulting pressure rise. Combustion products are toxic.	Same
Disposal procedures	Recycle or reclaim.	Same

Comparison of CFC12 and HFC134a Properties

Properties/Characteristics	CFC12	HFC134a
Ozone Depletion Potential (ODP)	1.0*	0.0*
Global Warming Potential (GPW)	3.2*	0.27*
Molecular weight	121	102
Boiling point at 1 atmosphere	-22°F (-30°C)	-15°F (-26°C)
Vapor pressure at 77°F (25°C)	80 psig	82 psig
Liquid density at 77°F (25°C)	82 lb/ft ³	75 lb/ft ³
Flammability	No	No
High-side system operating Pressure at 65°F (18°C)	HFC134a approximately 3 psig higher than CFC12	
Low-side system operating Pressure at 65°F (18°C)	HFC134a approximately 2 psig lower than CFC12	

Drier filter must always be replaced with service drier filter.

IMPORTANT: Unbrazing drier filter from tubing will drive moisture from desiccant and into system, causing acids to form. Do not unbrazed filter drier from tubing. If CFC12 service drier was installed in HFC134A system, drier could overload due to excessive moisture. HFC134a compatible copper tubing must be used when replacing tubing. Avoid system contamination when flaring, swagging, or cutting refrigeration tubing.

Brazing

CAUTION

To minimize contamination, exercise extreme care when servicing HFC134A sealed systems.

No trace of other refrigerants is allowed in HFC134a systems. Chlorinated molecules in other refrigerants such as CFC12, etc. will lead to capillary tube plugging. Ester oil is used in HFC134a systems. Do not use mineral oil. HFC134a and mineral oils cannot be mixed. If mineral oils were used in HFC134a systems, lubricant would not return to compressor and would cause early compressor failure. If significant amount of oil has been lost from compressor, replace oil rather than adding oil. Ester oils used in HFC134a systems are so hydroscopic that by the time an inadequate system performance is detected, oil will be saturated with moisture. CFC12 has much higher tolerance to system processing materials, such as drawing compounds, rust inhibitors, and cleaning compounds, than HFC134a. Such materials are not soluble in HFC134a systems. If materials were to be washed from system surfaces by ester oils, they could accumulate and eventually plug capillary tube. Care must be taken to minimize moisture entering HFC134a system. Do not leave compressor or system open to atmosphere for more than 10 minutes. Excessive moisture in HFC134a system will react with compressor oil and generate acid. Compressor must be replaced when performing low side leak repair.

CAUTION

To avoid risk of personal injury or property damage, take necessary precautions against high temperatures required for brazing.

Satisfactory results require cleanliness, experience, and use of proper materials and equipment. Connections to be brazed must be properly sized, free of rough edges, and clean. Generally accepted brazing materials are:
 Copper to copper joints:
 SIL-FOS (alloy of 15 percent silver, 80 percent copper, and 5 percent phosphorous). Use without flux. Recommended brazing temperature is approximately 1400°F. Do not use for copper to steel connection.
 Copper to steel joints:
 SILVER SOLDER (alloy of 30 percent silver, 38 percent copper, 32 percent zinc). Use with fluoride based flux. Recommended brazing temperature is approximately 1200°F.
 Steel to steel joints:
 SILVER SOLDER (see copper to steel joints).
 Brass to copper joints:
 SILVER SOLDER (see copper to steel joints).
 Brass to steel joints:
 SILVER SOLDER (see copper to steel joints).

Replacement Service Compressor

HFC134a service compressors will be charged with ester oil and pressurized with dry nitrogen. Before replacement compressor is installed, pull out 1 rubber plug. A pop from pressure release should be heard. If a pop sound is not heard, do not use compressor. Positive pressure in compressor is vital to keep moisture out of ester oil. Do not leave compressor open to atmosphere for more than 10 minutes.

Compressor Testing Procedures

WARNING

To avoid death or severe personal injury, never use oxygen, air or acetylene for pressure testing or clean out of refrigeration system. Use of oxygen, air, or acetylene may result in violent explosion. Oxygen may explode on contact with oil and acetylene will spontaneously explode when under pressure.

Refer to Technical Data Sheet "Temperature Relationship Chart" for operating watts, test points, and temperature relationship test for unit being tested.

Temperature testing is accomplished by using 3 lead thermocouple temperature tester in specific locations. Test point T-1 is outlet on evaporator coil and T-2 is inlet. Test point T-3 is suction tube temperature midway between where armaflex ends and suction port of compressor (approximately 12 inches from compressor). Thermocouple tips should be attached securely to specified locations.

Do not test during initial *pull down*. Allow one off cycle or balanced temperature condition to occur before proceeding with testing.

Refrigerator must operate minimum of 20 minutes after thermocouples are installed.

Turn control to colder to obtain required on time.

Wattage reading must be recorded in conjunction with temperature test to confirm proper operation.

Suction and head pressures are listed on "Temperature and Relationship Chart". Normally these are not required for diagnosis but used for confirmation on systems which have been opened.

Drier Replacement

Before opening refrigeration system, recover HFC134a refrigerant for safe disposal.

Every time sealed HFC134a system is repaired, drier filter must be replaced.

Cut drier out of system by completing the following steps. Do not unbraid drier filter. Applying heat to remove drier will drive moisture into system.

WARNING

To avoid risk of severe personal injury or death, cut drier at correct location. Cutting drier at incorrect location will allow desiccant beads to scatter. Completely clean area of beads, if spilled.

1. Score capillary tube close to drier and break.
2. Reform inlet tube to drier allowing enough space for large tube cutter.
3. Cut circumference of drier at 1-1/4", below condenser inlet tube joint to drier.
4. Remove drier.
5. Apply heat trap paste on post condenser tubes to protect grommets from high heat.
6. Unbraid remaining part of drier. Remove drier from system.
7. Discard drier in safe place. Do not leave drier with customer. If refrigerator is under warranty, old drier must accompany warranty claim.

Refrigerant Flow

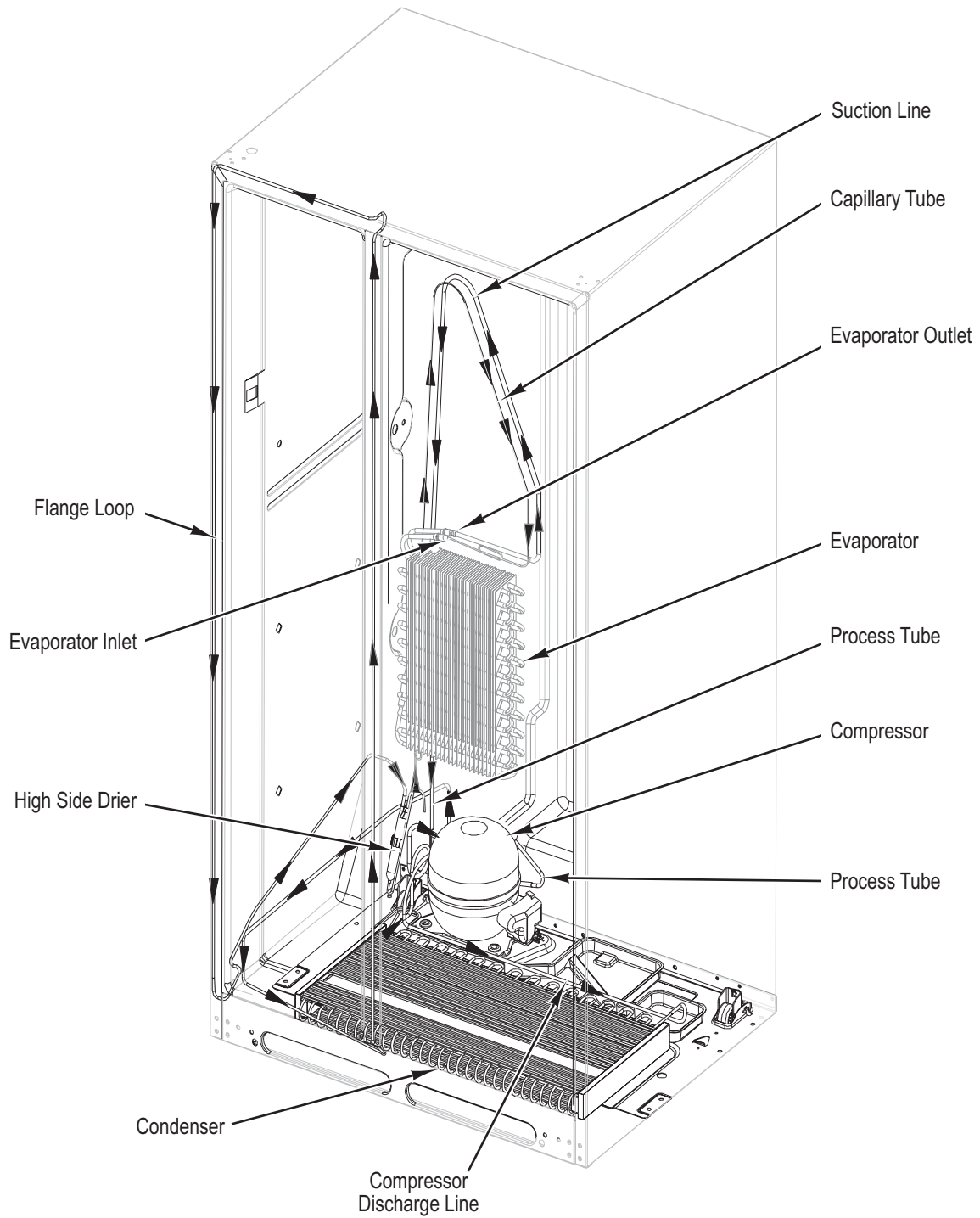

Cabinet Air Flow

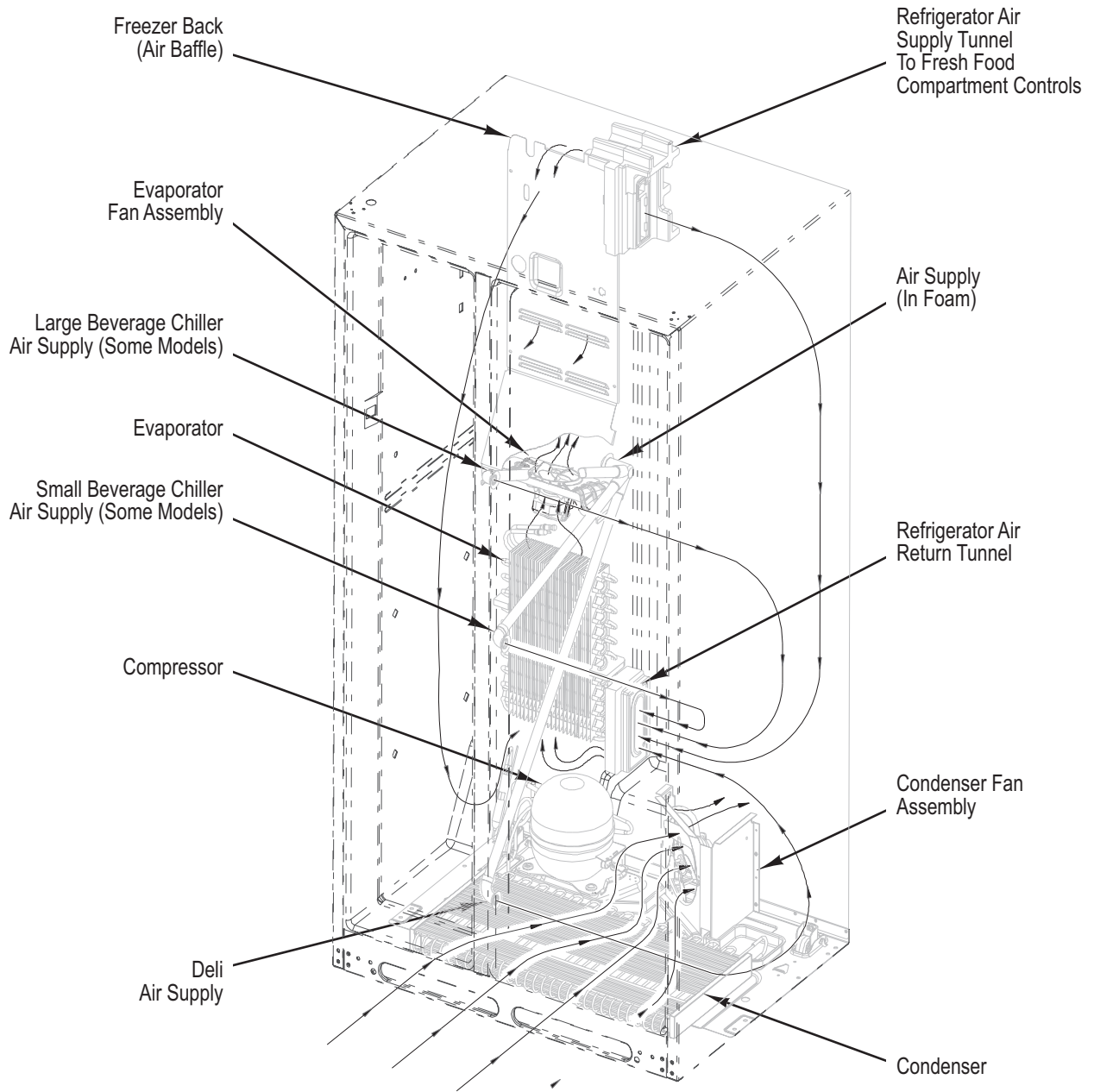

Water and Ice Dispenser

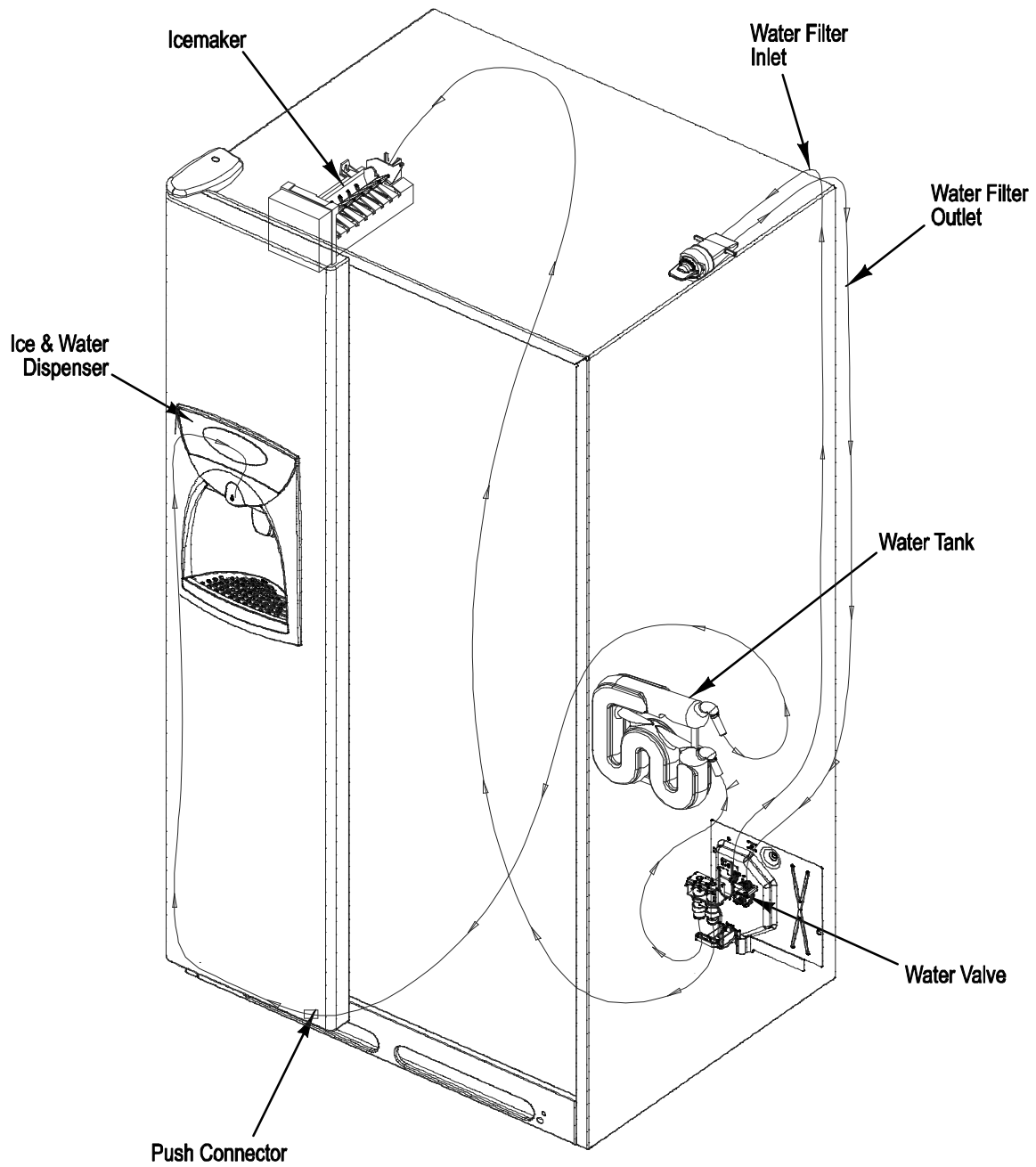

⚠ WARNING

To avoid risk of electrical shock, personal injury, or death, disconnect power to unit before servicing, unless testing requires power.

Upper Refrigerator Section Light Bulb Removal

⚠ CAUTION

Wear gloves when replacing light bulb.

Condition Requirements:

Door Opened

1. Reach behind the control panel to remove the bulbs.
2. Remove light bulb.
3. Replace bulb with appliance bulb no greater than 40 watts.

Crisper Section Light Bulb Removal

⚠ CAUTION

Wear gloves when replacing light bulb.

Condition Requirements:

Door Opened

Shelves Removed

1. Push up on bottom tabs on light cover. Rotate cover up and release tabs.
2. Remove light bulb.
3. Replace bulb with appliance bulb no greater than 40 watts.
4. Install light cover.

Light Switch Removal

Condition Requirements:

Door Opened

1. Use a taped putty knife to carefully pry light switch out of liner.
2. Disconnect two wires from the light switch and remove light switch from unit.

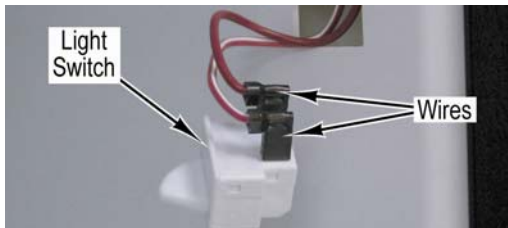

3. Reverse procedure for installation.

Electronic Control Removal

Condition Requirements:

Door Opened

1. Remove three screws holding control assembly to cabinet.
2. Disconnect two connectors from cabinet harness and remove control assembly.
3. Remove cover of board by squeezing tabs on cover to release cover from assembly to expose electronic control board.
4. Disconnect two connectors from the electronic control board and unclip from control assembly.

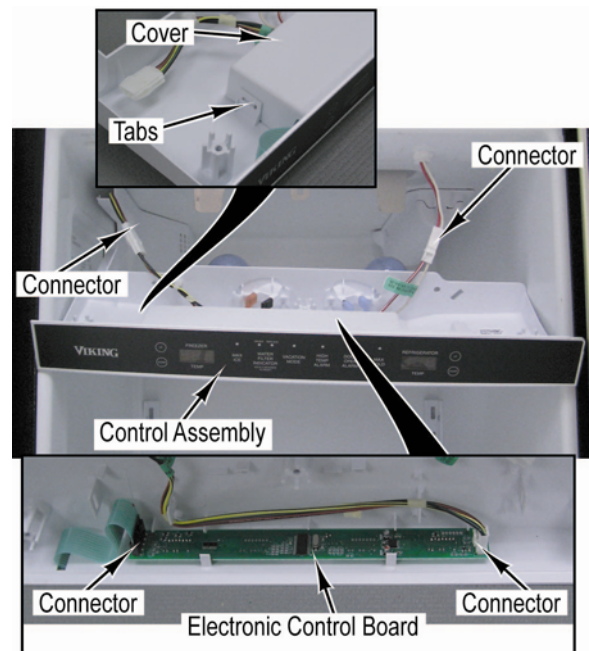

5. Reverse procedure for installation.

WARNING

To avoid risk of electrical shock, personal injury, or death, disconnect power to unit before servicing, unless testing requires power.

Electronically Controlled Damper Removal

Condition Requirements:

Electronic Control Removed

1. Remove screw and damper cover from damper.
2. Remove foam insert by pulling it off of damper control.



3. Depress two clips that hold front of damper in place to release damper from unit.
4. Disconnect connectors from damper and remove damper.

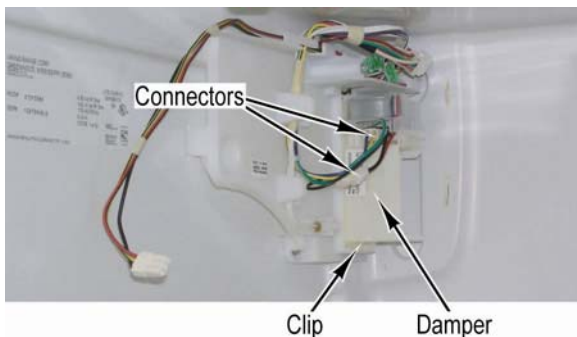

5. Reverse procedure for installation.

Refrigerator Thermistor Removal

Condition Requirements:

Electronic Control Removed

1. Remove screw and damper cover from damper.



2. Unclip thermistor from assembly.
3. Cut wires at thermistor to remove.

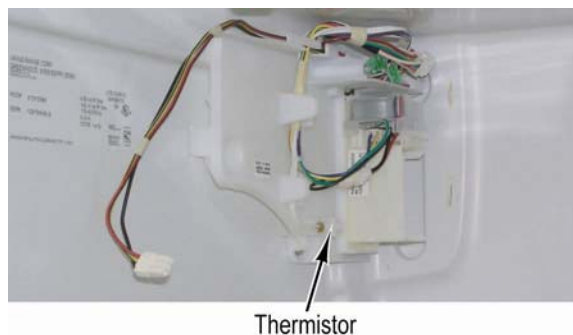

4. Reverse procedure for installation.

Crisper Light Cover and Socket Removal

Condition Requirements:

Crisper Section Light Bulb Removed

1. Use a taped putty knife to pry socket from liner.
2. Mark and disconnect wires from socket.

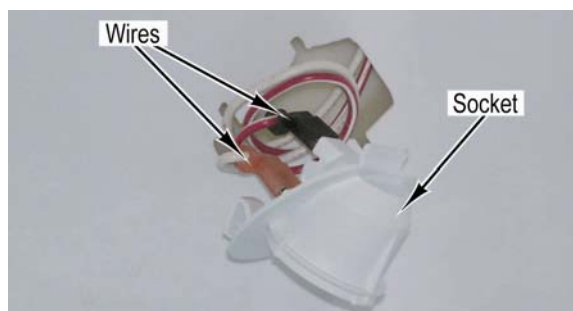

3. Reverse procedure for installation.

⚠ WARNING

To avoid risk of electrical shock, personal injury, or death, disconnect power to unit before servicing, unless testing requires power.

Water Filter Removal

⚠ CAUTION

Air trapped in system may cause water and cartridge to eject. Use caution when removing.

Condition Requirements:

Door Opened

Initial Installation

1. Remove blue bypass cap and retain for later use.
2. Remove sealing label from end of filter and insert into filter head.
3. Rotate gently clockwise until filter stops. Snap filter cover closed.
4. Flush air from system by running water continuously for two minutes through dispenser until water runs steady.

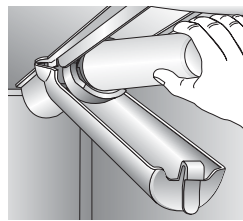
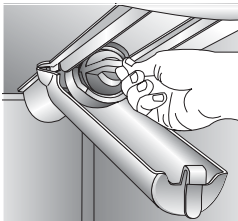

Replacing Water Filter

1. Turn filter counterclockwise until it releases from filter head.
2. Drain water from filter into sink, and dispose in normal household trash.
3. Remove sealing label from end of filter and insert into filter head.
4. Rotate gently clockwise until filter stops. Snap filter cover closed.
5. Flush air from system by running water continuously for two minutes through dispenser until water runs steady.

Access to Machine Compartment

Condition Requirements:

None

1. Remove seven screws and cover from the unit.
2. Remove power cord from cover.

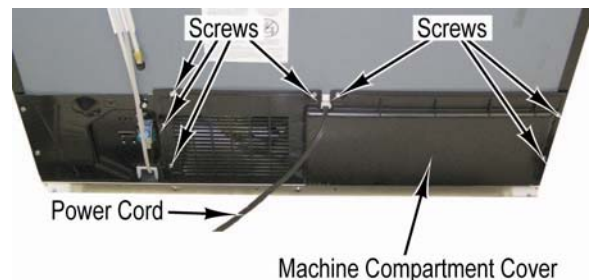

3. Reverse procedure for installation.

Water Filter Assembly Removal

Condition Requirements:

Water Filter Removed

Access to Machine Compartment

1. Remove filter cover by pulling rear left side of cover to the left to release cover from holding pin.
2. Filter head can be released from holding bracket by opening tabs on left side filter head and pulling downward and to your left to release filter head.

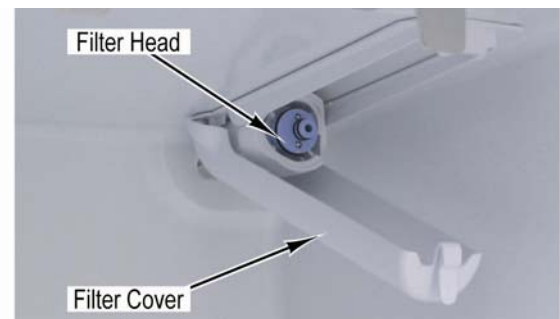

3. Tubing needs to be disconnected from water valve in the machine compartment. (See Water Valve removal).
4. After tubing is loose from water valve pull the filter head and tubing out the front of unit.

NOTE: Make sure to note tubing end colors when reinstalling new head and tubing assembly.

5. Reverse procedure for installation.

WARNING

To avoid risk of electrical shock, personal injury, or death, disconnect power to unit before servicing, unless testing requires power.

Water Tank Assembly Removal

Condition Requirements:

Drawers and Shelves Removed

Access to Machine Compartment

1. Remove toe grille and disconnect water tube going to water dispenser.

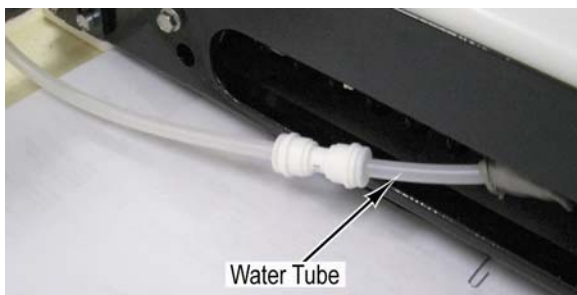

2. Remove screw holding water tank to rear bulkhead.
3. Tubing needs to be disconnected from water valve in the machine compartment (See Water Valve Removal).
4. From rear of cabinet pull water tube out of conduit going to dispenser.
5. From inside of fresh food compartment pull tubing up and out of cabinet to complete removal of water tank.

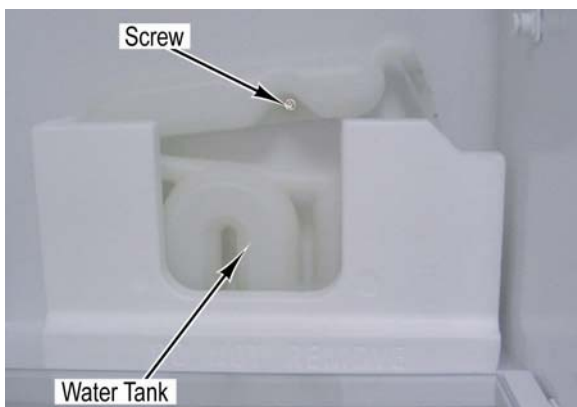

6. Reverse procedure for installation.

Water Valve Removal

Condition Requirements:

Access to Machine Compartment

1. Remove two screws and water valve cover plate assembly from the unit.
2. Disconnect two connectors from water valve assembly.
3. Mark and disconnect water tubing from water valve assembly.
4. Remove screw and water valve from water valve cover plate.

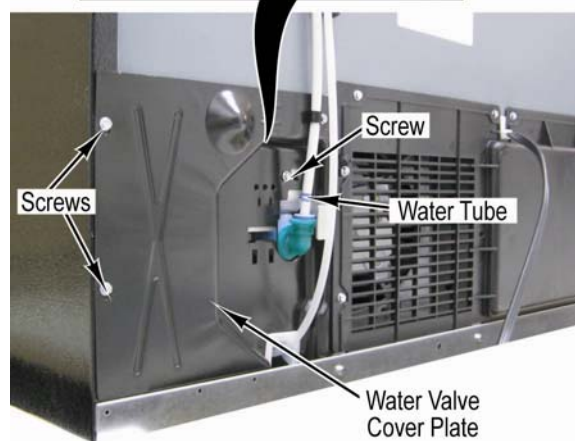
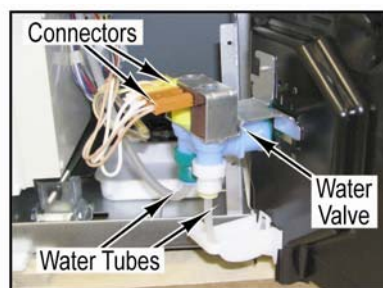

5. Reverse procedure for installation.

⚠ WARNING

To avoid risk of electrical shock, personal injury, or death, disconnect power to unit before servicing, unless testing requires power.

Upper Freezer Section Light Bulb Removal

⚠ CAUTION

Wear gloves when replacing light bulb.

Condition Requirements:

Ice Bin Removed

1. Remove light shield by pressing the upper right side of the shield and rotating downward.
2. Remove light bulb.
3. Replace with appliance bulb no greater than 40 watts.
4. Install light shield.

Auger Motor Assembly Removal

Condition Requirements:

Upper Freezer Light Bulbs Removed

1. Remove two screws from auger motor cover.
2. Lift and slide auger motor assembly toward the front, disconnect connectors and remove auger motor assembly.

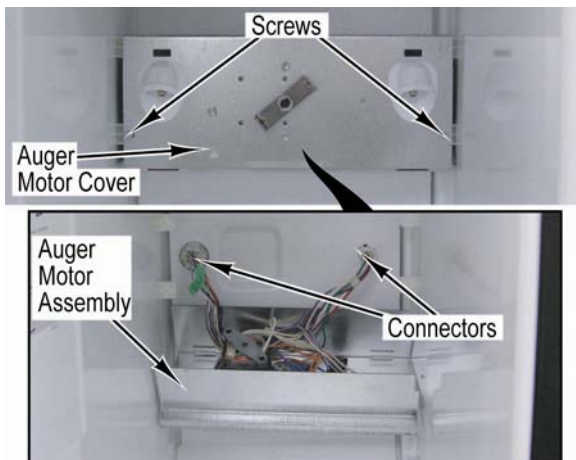

3. Reverse procedure for installation.

Upper Freezer Light Socket Removal

Condition Requirements:

Auger Motor Assembly Removed

1. Disconnect wires from light socket.
2. Squeeze retaining tab to release socket.

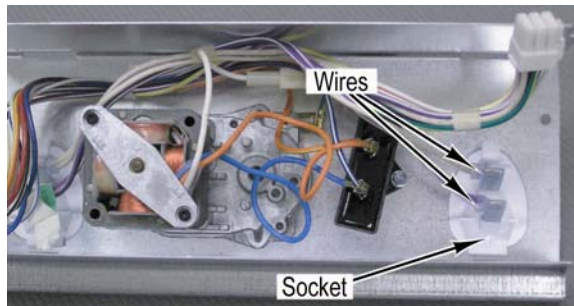

3. Reverse procedure for installation.

Auger Motor Capacitor Removal

Condition Requirements:

Auger Motor Assembly Removed

1. Disconnect wires from capacitor
2. Remove screw and capacitor from assembly.

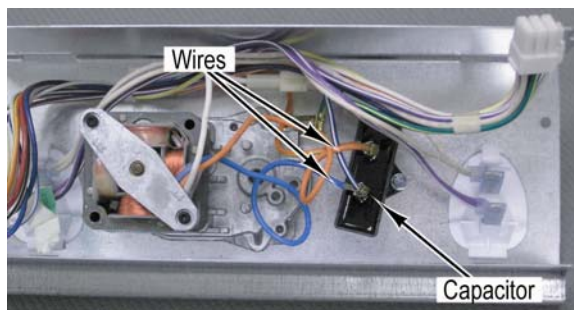

3. Reverse procedure for installation.

Lower Freezer Section Light Bulb Removal

⚠ CAUTION

Wear gloves when replacing light bulb.

Condition Requirements:

Freezer Shelves Removed

1. Remove light cover and light bulb.
2. Replace with appliance bulb no greater than 40 watts.
3. Reverse procedure for installation.

⚠ WARNING

To avoid risk of electrical shock, personal injury, or death, disconnect power to unit before servicing, unless testing requires power.

Auger Motor Removal

Condition Requirements:

Auger Motor Assembly Removed

1. Remove auger drive nut.
2. Remove three screws holding auger motor to assembly.
3. Disconnect wires from auger motor capacitor.

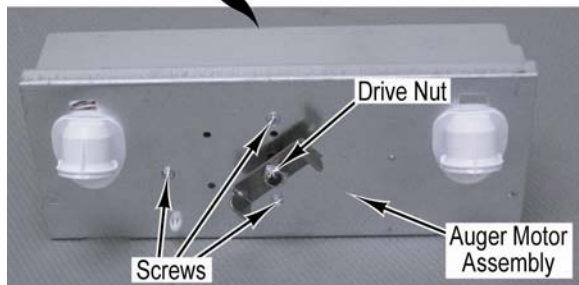
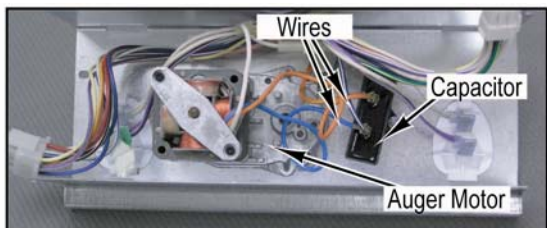

4. Reverse procedure for installation.

Evaporator Fan Motor Assembly

Condition Requirements:

Lower Freezer Light Socket Removed

1. Remove screws and lower evaporator cover.
2. Disconnect evaporator fan wiring and ground from motor.
3. Raise top freezer cover about two inches and pull complete evaporator motor assembly from freezer.



4. Reverse procedure for installation.

Evaporator Fan Motor and Fan Blade

Condition Requirements:

Evaporator Fan Motor Assembly Removed

1. Remove evaporator fan blade by pulling blade off evaporator fan shaft.
2. Remove fan motor by squeezing motor retainer clips together to release retainer.
3. Remove retainer and slide motor out.

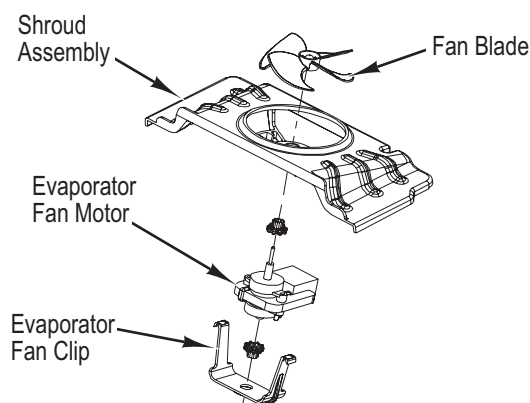

4. Reverse procedure for installation.

Defrost Thermostat Removal

Condition Requirements:

Lower Freezer Light Socket Removed

1. Disconnect orange lead from defrost heater.
2. Cut brown lead close to defrost thermostat.
3. Unclip defrost thermostat from evaporator coil.

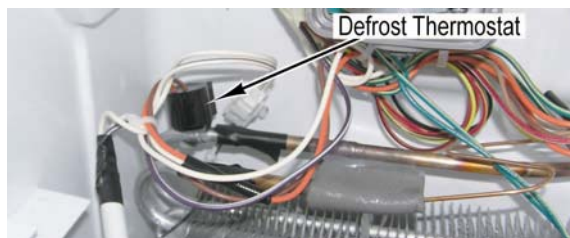

4. Replace thermostat and use wire nut(s) included in defrost thermostat kit.
5. Reverse procedure for installation.

⚠ WARNING

To avoid risk of electrical shock, personal injury, or death, disconnect power to unit before servicing, unless testing requires power.

Defrost Heater Removal

Condition Requirements:

Lower Freezer Light Socket Removed

1. Disconnect defrost heater connector from harness.
2. Release heater clips and remove heater from evaporator coil.

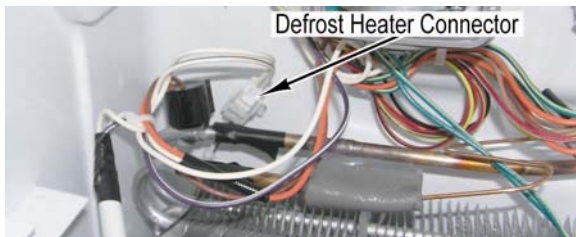

3. Reverse procedure for installation.

Evaporator Removal

Condition Requirements:

Defrost Heater Removed

Defrost Thermostat Removed

NOTE: Reclaim refrigerant per instructions in Service Procedures before attempting evaporator removal. To avoid system contamination, do not leave system open for more than 10 minutes.

1. Unbraid evaporator coil after completing reclaiming procedures found in Service Procedures section of this manual.
2. Release evaporator coil from clips by pulling coil off of clips.

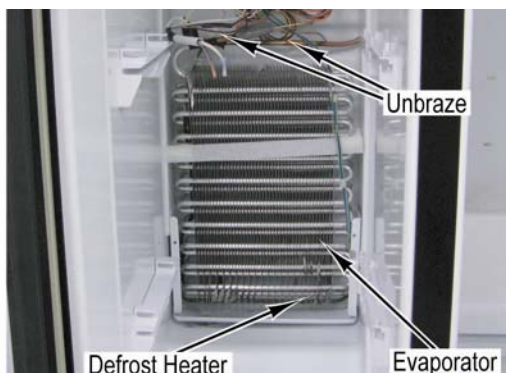

3. Reverse procedure for installation.

Ice Maker Removal

Condition Requirements:

Auger Ice Bucker Removed

NOTE: Note position of fill tube before removing ice maker.

1. Disconnect ice maker harness from rear bulkhead.
2. Loosen two screws that hold ice maker to left side of freezer cavity.
3. Remove screw and ice maker from freezer.

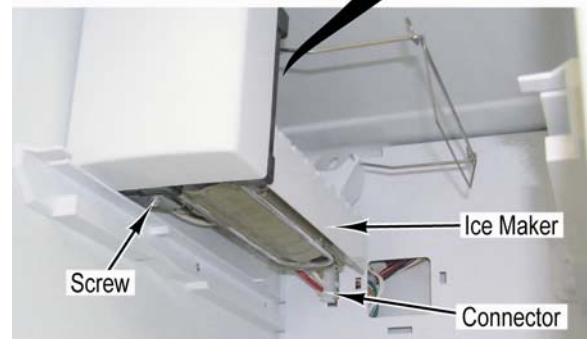

4. Reverse procedure for installation.

NOTE: Make sure to get fill tube inserted in to fill cup fully when reassembling.

WARNING

To avoid risk of electrical shock, personal injury, or death, disconnect power to unit before servicing, unless testing requires power.

Freezer Thermistor Removal

Condition Requirements:

Ice Maker Removed

1. Push thermistor retainer through the back freezer panel.
2. Cut wire at thermistor and remove thermistor.

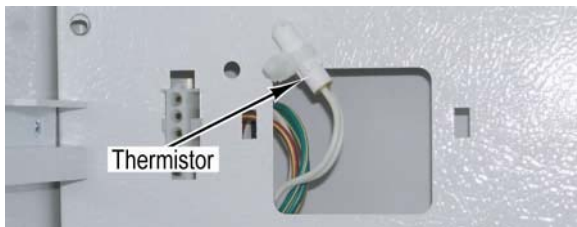

3. Reverse procedure for installation.

Condensate Drain Tube

Condition Requirements:

Access to Machine Compartment

1. Remove screw and clamp from drain tube.
2. Remove drain tube by pulling down on drain tube.

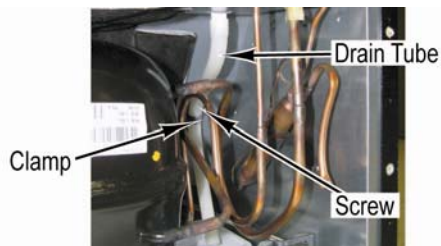

3. Reverse procedure for installation.

Overload/Relay Removal

Condition Requirements:

Access to Machine Compartment

1. Discharge capacitor through a 10,000-ohm resistor.
2. Using fingers and standard screwdriver, press and pry bale strap off the overload/relay/capacitor assembly.
3. Reverse procedure for installation.

Compressor Removal

Condition Requirements:

Access to Machine Compartment

1. Remove bale strap which retains overload/relay/capacitor.
2. Pull overload/relay/capacitor assembly off of compressor terminals.
3. Disconnect ground wires attached to compressor.
4. Follow reclaiming procedures in Service Procedures section of this manual.

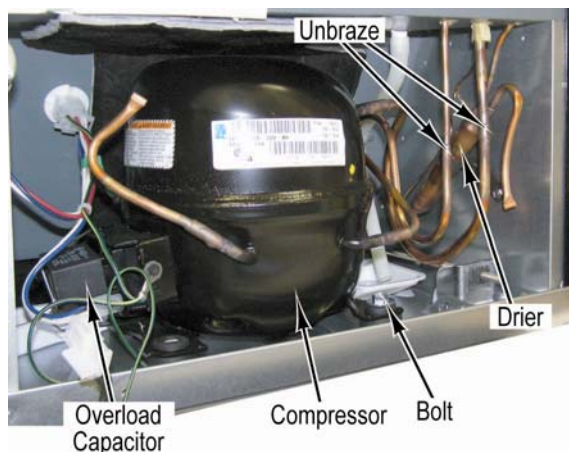

5. Remove drier. See Drier Removal.
6. Unbraid low and high pressure lines at compressor.
7. Remove three bolts and compressor from the unit.

NOTE: Install new drier and compressor per instructions in "Service Procedures." Evacuate and recharge sealed system per instructions in Service Procedures.

⚠ WARNING

To avoid risk of electrical shock, personal injury, or death, disconnect power to unit before servicing, unless testing requires power.

Condenser Fan Motor and Blade Removal

Condition Requirements:

Access to Machine Compartment

1. Disconnect connector from condenser motor.
2. Remove two screws from mounting brackets attached to motor.
3. Remove motor and fan blade out the rear of shroud.
4. Remove the retainer nut to remove fan blade.

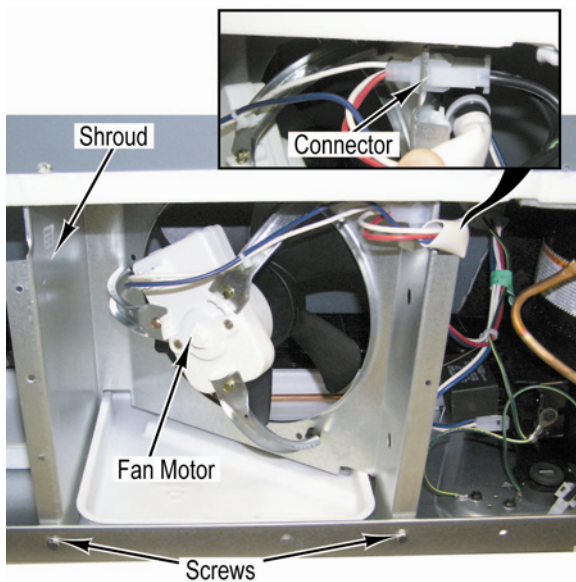

5. Reverse procedure to reassemble.

Condensate Drip Pan Removal

Condition Requirements:

Compressor Removed

Condenser Fan Motor Removed

Water Valve Assembly Removed

NOTE: Condensate drip pan may have water in it. Wipe up all water prior to removal.

1. Bend copper tubing up out of condensate pan to allow removal of condensate pan.
2. Reverse procedure for installation.

Condenser Removal

Condition Requirements:

Condenser Fan Motor Removed

Compressor Removed

NOTE: Condenser is removed by laying unit on its back and requires at least two people to do this procedure.

1. Follow reclaiming procedures in Service Procedures section of this manual.
2. With the help of second person lay unit on back on raised surface.
3. Remove four torx head screws holding basepan to cabinet.
4. Lift and remove basepan to access condenser coil.
5. Unbraid condenser coil from connecting tubing.
6. Remove condenser coil by unsnapping it from retainers in basepan.

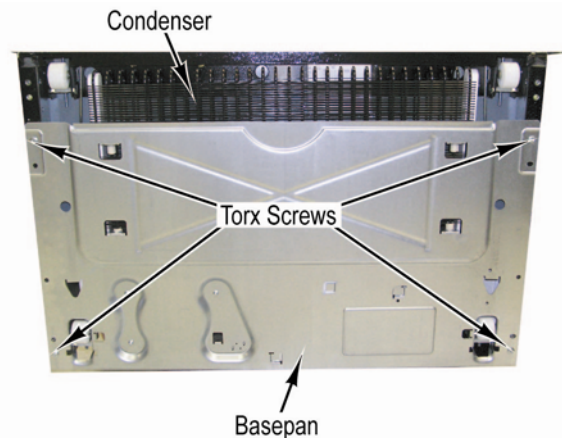

7. Reverse procedure for installation.

⚠ WARNING

To avoid risk of electrical shock, personal injury, or death, disconnect power to unit before servicing, unless testing requires power.

Front and Rear Leveling Rollers Removal

Condition Requirements:

None

NOTE: The front and rear leveling rollers are removed the same. The front is shown in this task.

1. Remove toe grille.
2. Raise and block unit to access roller.
3. Screw leveler bolts until they are loose from leveling roller.
4. Slide leveling roller out rear of slot.

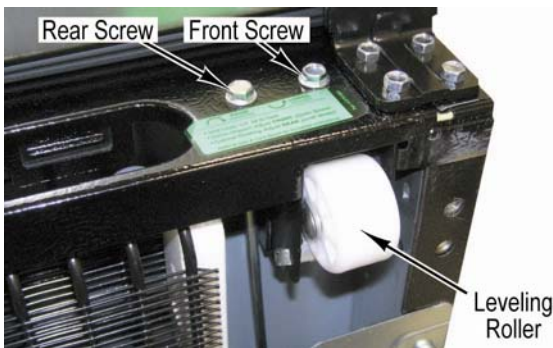

5. Reverse procedure for installation.

Door Gasket Removal

Condition Requirements:

None

1. Grasp gasket in upper corners and pull gasket out of dart retainer.
2. When reinstalling door gaskets start at corners pushing dart edge into retainer and seat gasket flush to door.

Dispenser Light Bulb Removal

⚠ CAUTION

Wear gloves when replacing light bulb.

Condition Requirements:

None

1. Locate light bulb inside top edge of dispenser frame and remove bulb.
2. Replace light bulb with a 7-watt, 120 volt bulb.

Dispenser Façade Removal

Condition Requirements:

None

1. Remove drip tray by pulling it out from door.
2. Remove two screws at the bottom of facade that were hidden by drip tray.
3. Push down on facade to release retainer clips.
4. Remove facade and disconnect connector from control board.

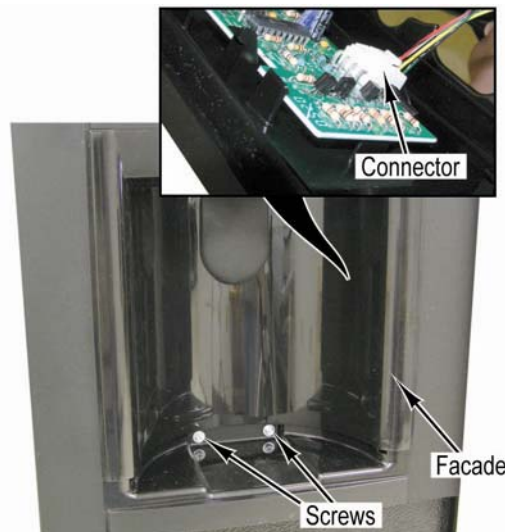

5. Reverse procedure for installation.

Dispenser Light Socket

Condition Requirements:

Dispenser Façade Removed
Dispenser Light Bulb Removed

1. Disconnect wires from light socket.
2. Squeeze tabs by terminals to release socket.

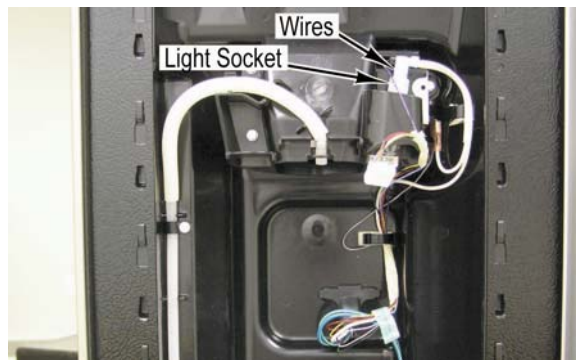

3. Reverse procedure for installation.

⚠ WARNING

To avoid risk of electrical shock, personal injury, or death, disconnect power to unit before servicing, unless testing requires power.

Dispenser Pad and Switch Removal

Condition Requirements:

Dispenser Façade Removed

1. Disconnect switch connector from dispenser board.
2. Unsnap switch from dispenser façade.
3. Push in white tabs to remove dispenser pad.

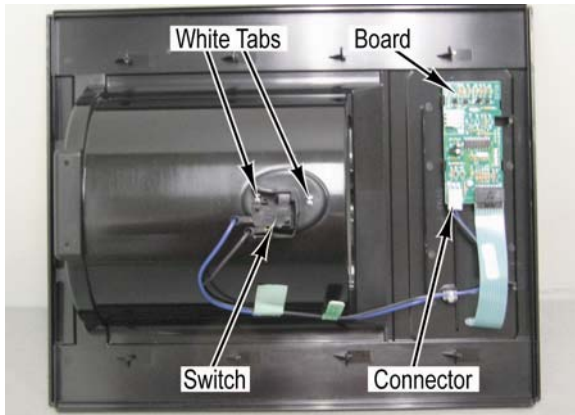

4. Reverse procedure for installation.

Dispenser Board Removal

Condition Requirements:

Dispenser Façade Removed

1. Disconnect switch connector from dispenser board.
2. Disconnect ribbon cable from dispenser board.
3. Unsnap board from dispenser façade.

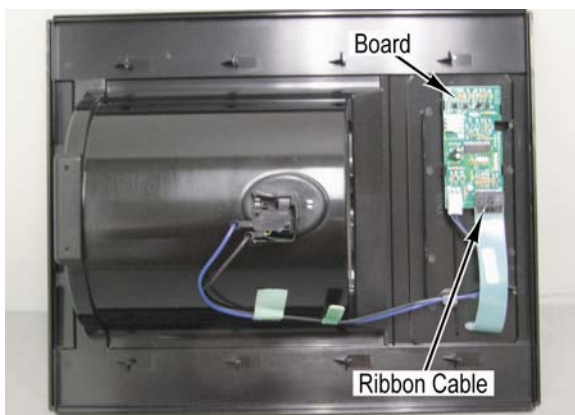

4. Reverse procedure for installation.

Dispenser Ice Chute Door and Solenoid Removal

Condition Requirements:

Dispenser Façade Removed

1. Remove dispenser water tube from ice chute assembly.
2. Disconnect wires from light socket.
3. Disconnect wires from solenoid.
4. Remove three screws holding ice chute assembly to door.

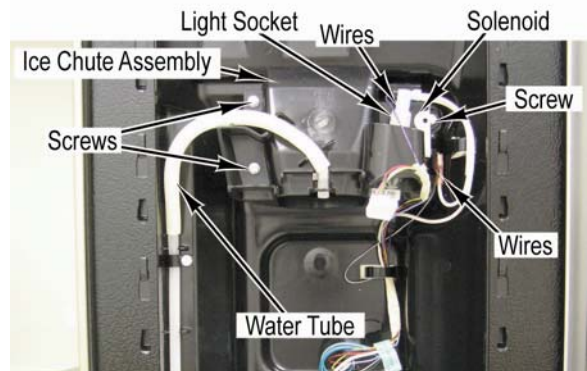

5. Unsnap ice chute dispenser door from assembly.
6. Slide solenoid out of the side of ice chute assembly.
7. Retain spring if good, replace if bad.
8. Remove rubber seal from door and replace if bad.

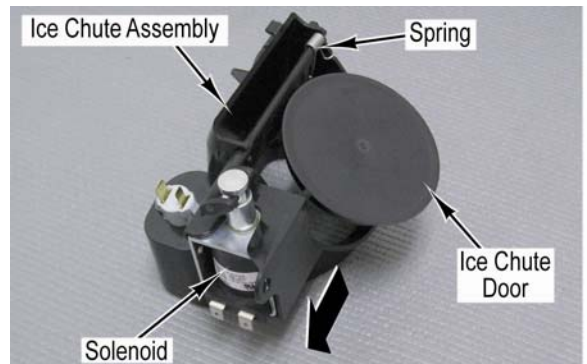

9. Reverse procedure for installation.

WARNING

To avoid risk of electrical shock, personal injury, or death, disconnect power to unit before servicing, unless testing requires power.

Dispenser Water Tube Removal

Condition Requirements:

Dispenser Façade Removed

1. Remove toe grille and disconnect water tube going to water dispenser.

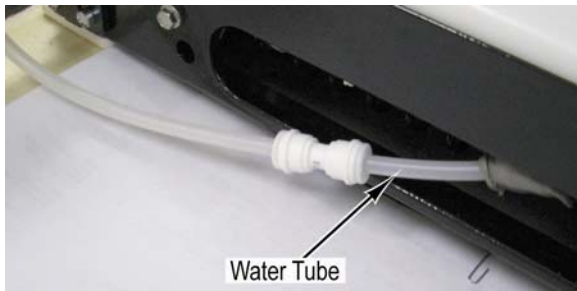

2. Remove dispenser water tube from ice chute assembly.
3. Pull water tube up from conduit in cavity to remove water tube.

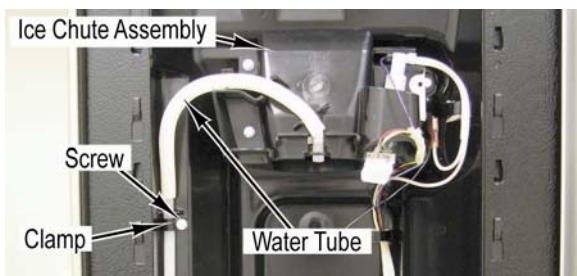

4. Reverse procedure for installation.

Door and Hinge Removal

Condition Requirements:

None

1. Remove toe grille.
2. Remove screw and top hinge cover.
3. Disconnect connectors from door.
4. Remove screws from top hinge.

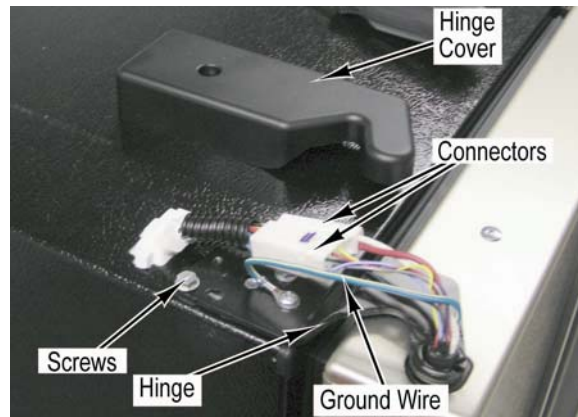

NOTE: Do not remove green ground wire from hinge.

5. Remove top hinge along with door.
6. Remove screw and bottom hinge.
7. Reverse procedure for installation.

**WARNING**

To avoid risk of electrical shock, personal injury, or death, disconnect power to unit before servicing, unless testing requires power.

Door Handle Removal**Condition Requirements:**

None

1. Remove plastic button plug at base of handle with a very small flat-blade screwdriver.
2. Insert phillips screwdriver into predrilled hole to remove screw.
3. Slide handle down and remove from door clip.

Door Handle Installation

1. Loosen lower door clip on door with a phillips screwdriver.
2. Locate predrilled hole at base of handle, and fit hollow end of handle over lower door clip.
3. Fit other end of handle over upper door clip and slide up as far as possible.

NOTE: If top of handle does not fit over top clip, loosen lower clip further until fit can be accomplished.

4. Insert phillips screwdriver into predrilled hole at base of handle to tighten screw. Insert plastic button plug into hole.

