

TECHNICIAN TESTED

TECHNIQUES

BY

Viking Preferred Service

TECH – NOTES

VCBB360 / VCBB362

REFRIGERATORS

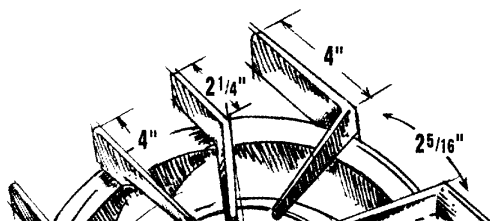

VIKING[®]
Preferred Service

Technical Information – Refrigerator



To avoid electrical shock which can cause severe personal injury or death, disconnect power to refrigerator using power switch before servicing. Wires removed during disassembly must be replaced on proper terminals to insure correct earth ground and polarization. After servicing, reconnect power using power switch.

	Kw/24 hr ± 0.4	Percent Run Time ± 10%	Cycle/24 hr ± 25%	Refrigerator Center Compartment Food Average temperature ± 3°F	Freezer Compartment Food Average Temperature ± 3°F	
Ambient °F	65° 90° 110°	65° 90° 110°	65° 90° 110°	65° 90° 110°	65° 90° 110°	
	1.2 2.3 4.2	28 52 100	30 32 0	39 39 45	3 3 3	
Temperature Relationship Test Chart						
	T-1 Outlet ± 3°	F T-1 Inlet ± 3° F	T-3 Suction Line	Average Total Wattage ±10%	Suction Pressure ± 2 PSIG	Head Pressure ± 5 PSIG
			± 7°F			
Ambient °F	65° 110°	65° 110°	65° 110°	65° 110°	65° 110°	65° 110°
	-14 -14	-14 -14	25 103	157 168	0 0	110 157

Refrigerant Flow

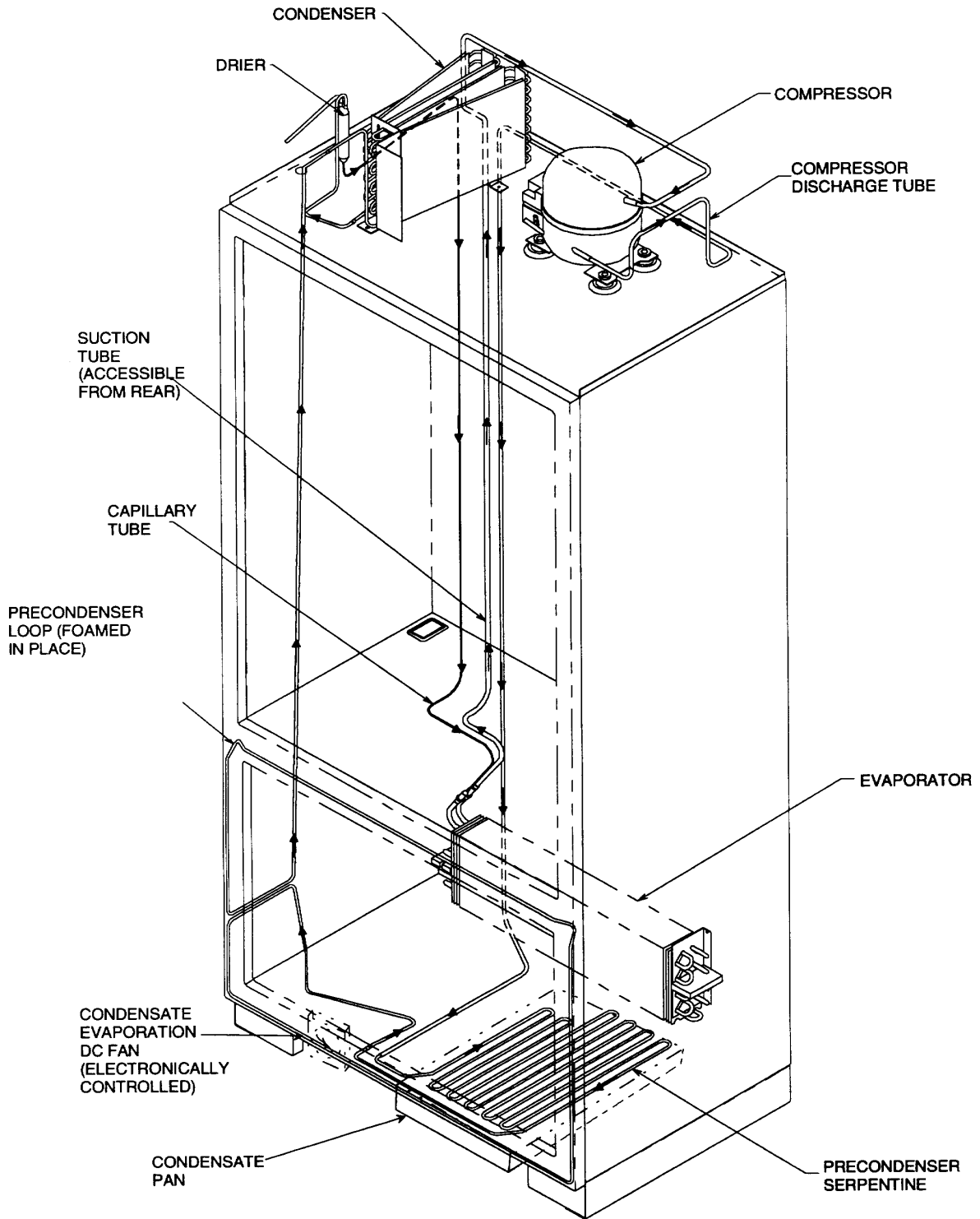

Cabinet Air Flow

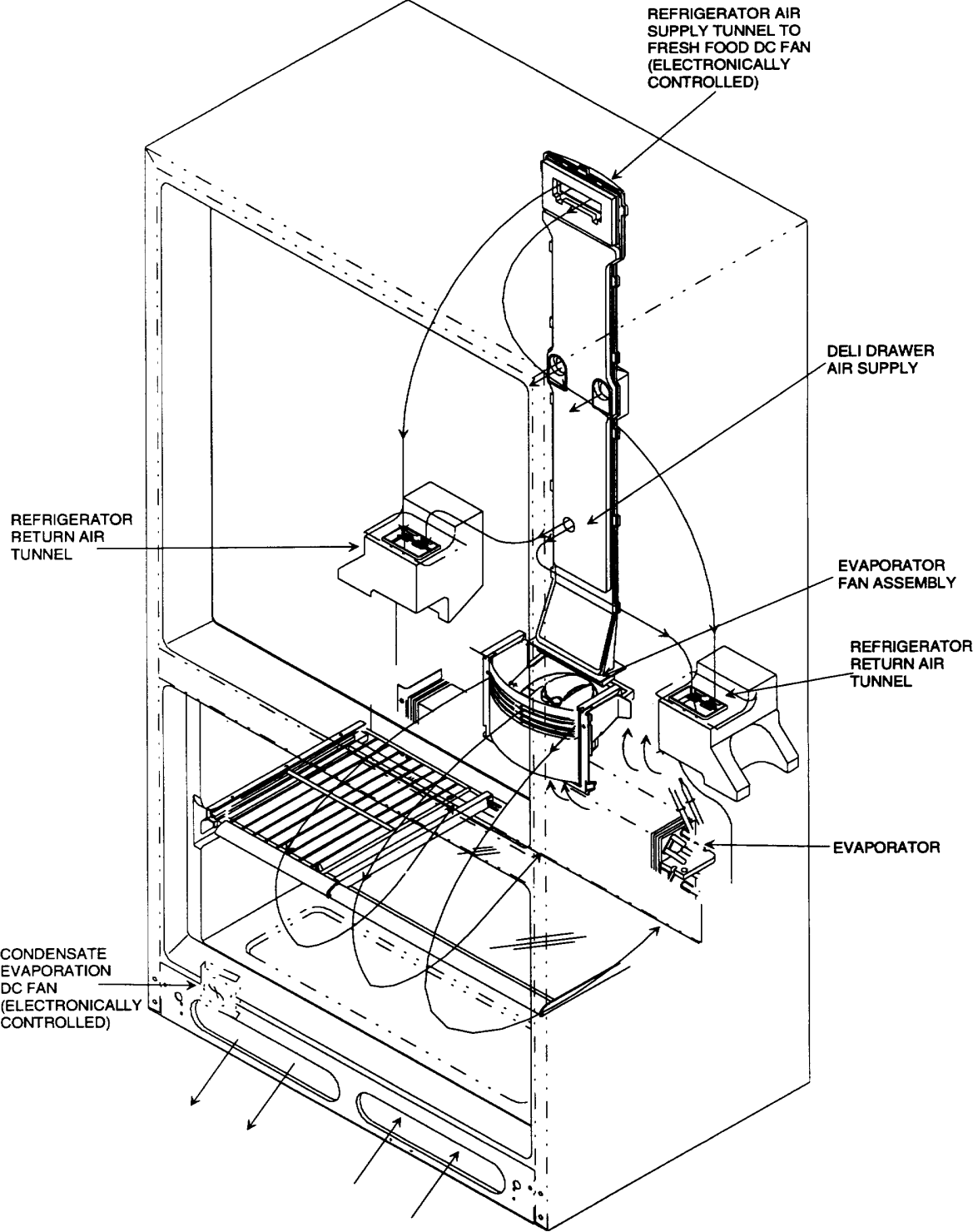

Machine Compartment Air Flow

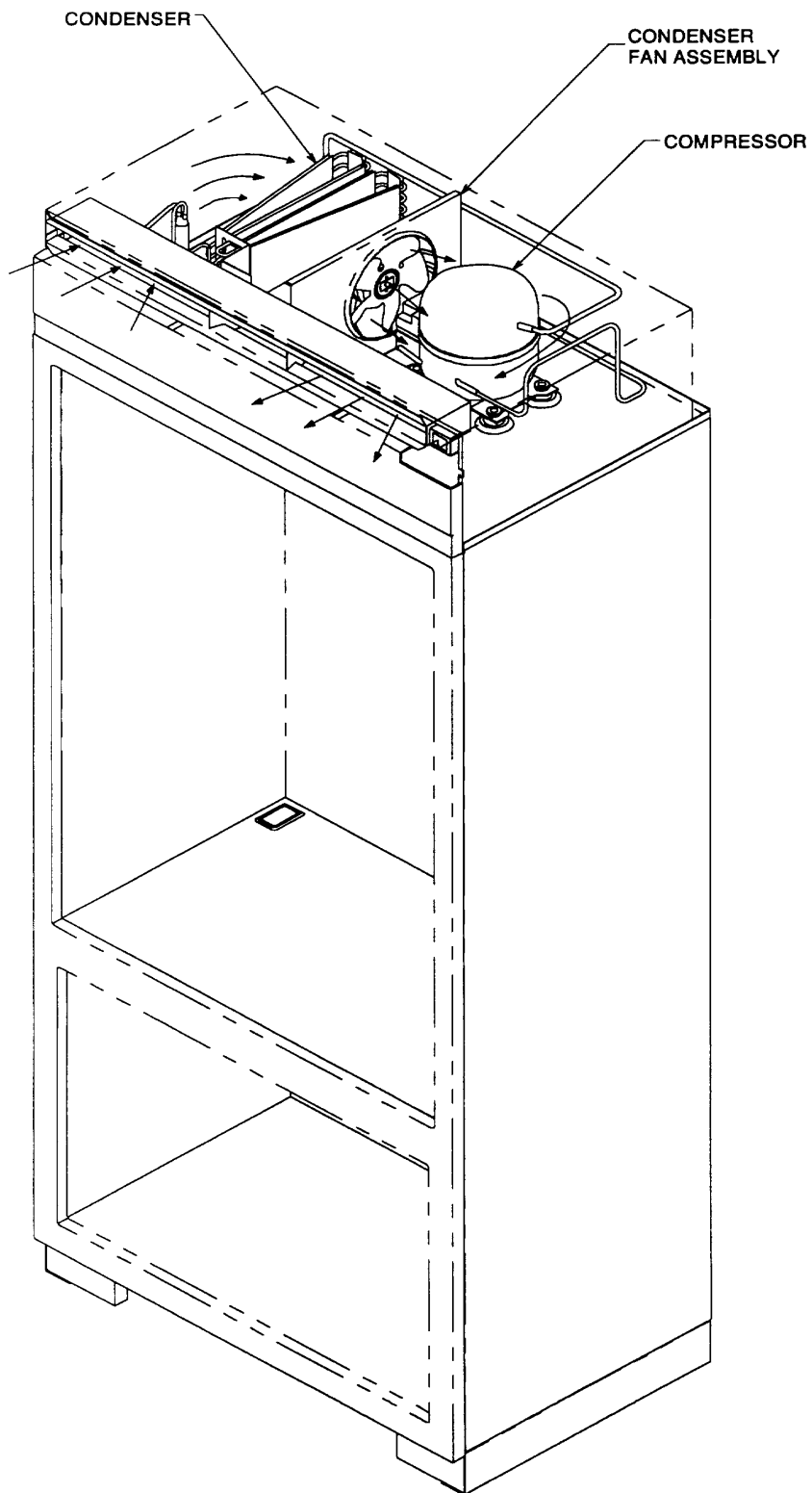

Typical External Sweat Pattern

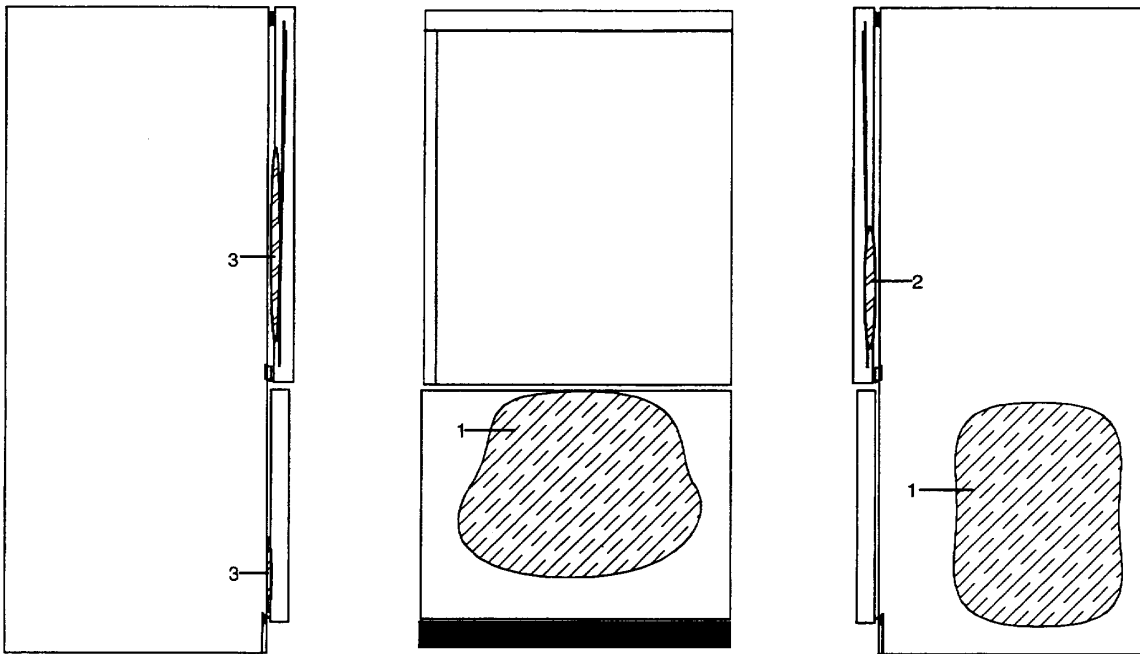

CLASSIFICATION OF CONDENSATION

- 1 = HAZE OR FOG
- 2 = BEADING
- 3 = BEADS OR SMALL DROPS
- 4 = DROPS RUNNING TOGETHER

TEST CONDITIONS
 ROOM AMBIENT = 90°F
 WET BULB = 85.8°F
 RELATIVE HUMIDITY = 84%
 TEST LENGTH = 4 HOURS

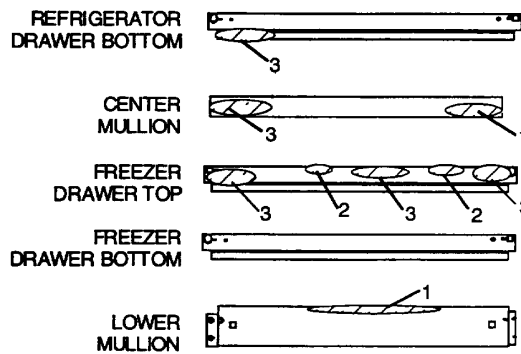
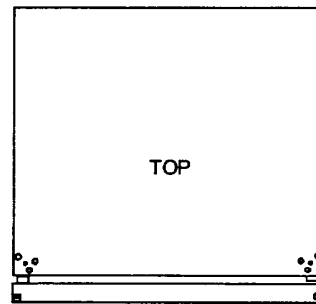
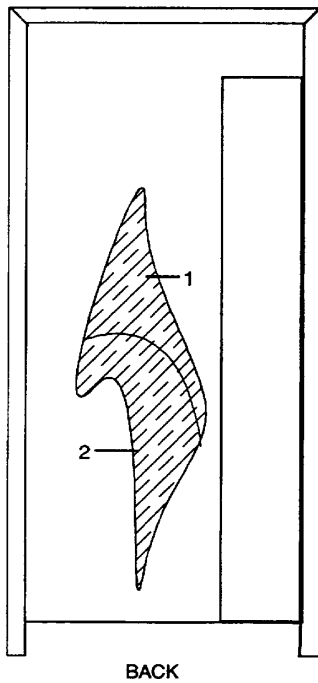

Display Panel

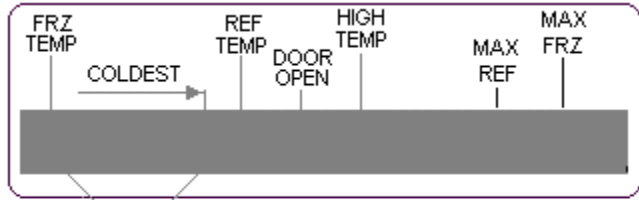

TEMPERATURE
DISPLAY LIGHTS

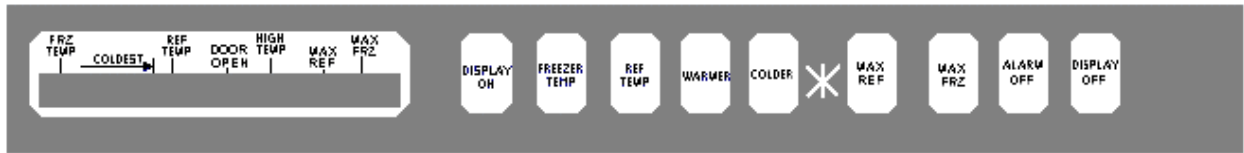
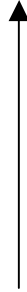

Display Panel Keyboard

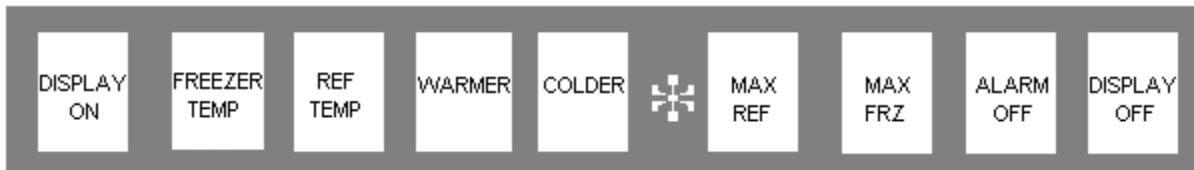

Display Panel Operation

Keyboard Tone

Entry Tone

Indicates a pad was pressed, command read and accepted, Turn off entry tone by pressing and holding *Display On* pad for 3 to 5 seconds.

Command Accepted Tone

Three short tones indicate command accepted.

Display On Pad

1. Activates control panel. Control panel remains active at least 10 minutes.
2. Turns off Power Up Alarm (flashing lights) after power is first plugged in or after power outage.

Note: All pads, except *Alarm Off*, are inactive until *display On* is pressed.

Freezer Temp Pad

Activates freezer temperature settings mode.

1. Freezer indicator light will glow. Freezer temperature setting will be displayed. Factory setting is 5.
2. Change freezer temperature setting by pressing *Warmer* or *Colder* pad.

Ref Temp Pad

Activates refrigerator temperature settings mode.

1. Refrigerator indicator light will glow. Refrigerator temperature setting will be displayed. Factory setting is 5.
2. Change refrigerator temperature setting by pressing *Warmer* or *Colder* pad.

Warmer Pad

Raises temperature settings one bar at a time. If entry tone is on, tone will sound at each bar level until top level is reached.

1. Turn on temperature setting function of control panel by pressing *Warmer* pad.
2. Press and hold *Warmer* pad to raise temperature setting at a faster rate.

Colder Pad

Lowers temperature setting one bar at a time. If entry tone is on, tone will sound at each bar level until bottom level is reached.

1. Turn on temperature setting function of control panel by pressing *Colder* pad.
2. Press and hold *Colder* pad to lower temperature setting at a faster rate.

Max Frz Pad

Activates Maximum freezer mode setting freezer temperature to coldest setting for 24 hours or until *Max Frz* pad is pressed again.

1. Freezer indicator light will glow.
2. To adjust maximum freezer mode time refer to Program Mode B functions.

Max Ref Pad

Activates Maximum refrigerator mode setting refrigerator to coldest setting for 24 hours or until *Max Ref* pad is pressed again.

1. Refrigerator indicator light will glow.
2. To adjust maximum refrigerator time refer to Program Mode B functions.

Alarm Off Pad

Turns off alarm signals. See Alarms section to interpret alarm signals.

1. Press and hold *Alarm Off* pad for 3 seconds to deactivate *Door Open* alarm. To reactivate *Door Open alarm*, press and hold *Alarm Off* pad for 3 seconds.
2. If *Alarm Off* pad is pressed and condition causing alarm is not corrected, alarm will reset.

**

Activates Program Mode. See Program Mode section for description of functions available.

1. Open refrigerator door.
2. Press *Display On* pad.
3. Press * pad.
4. Within 6 seconds press the following pads in this sequence; *Max Ref*, *Max Frz*, *Max Ref*, *Max Frz*.
5. Tone will sound 3 times and control will be in program mode A.

Display Off Pad

1. Deactivates control panel
2. Deactivates temperature indication area of control panel.

Electronic Functional Description

Power Disconnect Switch

Use power disconnect switch to disconnect power without unplugging refrigerator. Power disconnect switch is located behind air grille on top right side. Refrigerator is shipped with power disconnect switch in the on position.

Showroom Switch

Showroom switch allows electronic controls and interior lights to function independently of refrigeration system. Showroom switch is located behind air grille to right of control panel. Refrigerator is shipped with showroom switch in the unit run position.

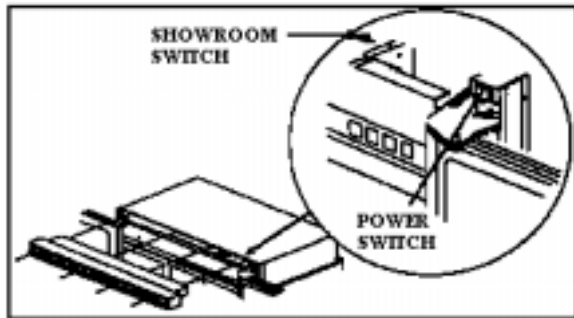

Alarms

Power Up Alarm

After power is initially plugged in, after a power loss, or if power switch is turned off, all temperature indicator lights will flash until *Alarm Off* or *Display On* is pressed.

Note: All settings return to default factory settings.

Door Open Alarm

Alarm tone sounds and indicator lights blink if either refrigerator or freezer door is open more than 3 minutes.

1. Turn off Door Open alarm by pressing *Alarm Off* pad or by closing door.
2. Deactivate door open alarm by pressing *Display On* pad and then press and hold *Alarm Off* pad for 3 seconds.
3. Door alarm delay can be adjusted in Program Mode B.

High Temperature Alarm

Alarm sounds and indicator light shows if freezer or refrigerator temperature has gone above critical level and remains warm for 2 hours. Alarm tone stops if temperature falls again.

1. Critical temperature for freezer is +15°F; for refrigerator critical temperature is +55°F.
2. Press *Alarm Off* to turn off alarm.

Thermistor Alarm

Alarm sounds and freezer or refrigerator indicator light shows and temperature indicators 4 through 7 will turn on in sequence if either thermistor circuit opens. Refer to Temperature Control Operation Section and Electronic Testing Section.

1. Press *Alarm Off* pad to turn off alarm.
2. Alarm will reset for normal operation. If condition has not been corrected, alarm will sound again.

Electronic Functional Description

Temperature Control Operation

For any temperature setting, outputs will be turned off/on based on cut-in, cut-out temperatures determined by resistance levels of freezer and refrigerator thermistors.

Refrigerator and Freezer Thermistor

Temp °F (+°C)	Resistance Ohms	Temp °F (+°C)	Resistance Ohms
-20 (-29)	495600	36 (2)	87510
-15 (-26)	418200	38 (3)	82740
-9 (-23)	354000	39 (4)	78300
-6 (-21)	300600	43 (6)	74100
-4 (-18)	256200	45 (7)	70170
5 (-15)	218850	46 (8)	66450
10 (-12)	187470	48 (9)	62970
16 (-9)	161040	50 (10)	59670
19 (-7)	138690	55 (13)	52290
25 (-4)	119760	61 (16)	45900
30 (-1)	103680	64 (18)	40410
32 (0)	97920	70 (21)	36540
34 (1)	92550	77 (25)	30000

As temperature decreases, resistance increases.

As temperature increases, resistance decreases.

Open thermistor or thermistor circuit will result in failure of refrigerator to cool.

Shorted thermistor will cause refrigerator to run 100 percent of time except for defrost cycle.

- Freezer temperature setting and thermistor value will determine if compressor/condenser fan and evaporator fan switches are open or closed. Compressor/condenser fan switch must be open for 6 minutes before switch can close again (compressor dwell time.)
- Refrigerator temperature setting and thermistor valve will determine if fresh food fan switch is open or closed.
- Cut-out and cut-in temperature values must be reached and maintained for 15 minutes before output state will change (digital delay).
- Refrigerator and freezer control calibration can be adjusted in Program Mode B.

Factory set freezer and refrigerator settings.

Electronic Functional Description

Adaptive Defrost Operation

Defrost occurs after predetermined length of compressor run hours. Compressor run time between defrost changes, or adapts, depending upon recent history of defrost lengths (time it takes for defrost terminator to open after defrost heater has been turned on).

- Defrost terminator opens at 55°F (-13°C) and closes at 20°F (-7°C).
- Compressor run time between defrost (CRDT) will be one of 3 values under normal operation CRDT 1 (8 hours) or CRDT 2 (12 hours) or CRDT 3 (15 hours).

If defrost length is low (DT-LO defined as 21 minutes) indication small frost load, CRDT for next defrost cycle is advanced to next level.

If defrost length is high (DI-HI defined as 24 minutes) indicating large frost load, CRDT for next defrost cycle is lowered to next level.

If defrost length is between 21 and 24 minutes, CRDT for next defrost cycle remains the same.

Initial value at power up CRDT is 4 hours.

- Vacation Mode CRDT equals 96 hours. Vacation Mode CRDT is interrupted with door openings. Defrost interval will revert back to interval before vacation mode. Three things must occur to reach Vacation Mode CRDT.
 - 1) Defrost interval must be CRDT 3 (16 hours).
 - 2) Both refrigerator and freezer doors must have remained closed since last defrost cycle.
 - 3) Defrost thermostat must have opened in less than 21 minutes during last defrost cycle.
- Six minutes dwell time occurs after defrost terminator opens before compressor and condenser fan motor will operate. Ten minutes dwell time occurs after defrost terminator opens before evaporator fan motor will operate. Dwell time can be bypassed by disconnecting power to the unit for 30 seconds.
- Conventional defrost can be selected in Program Mode B.

Program Mode

Accessing Program Mode

Two programming modes are available. Mode A allows reading refrigerator and freezer thermistor temperatures. Mode B is used for all other programmable functions.

1. Open refrigerator door.
2. Press *Display On* pad.
3. Press * pad.
4. Press the following sequence of pads within 6 seconds; Max Ref, Max Frz, Max Ref, Max Frz.
5. When access is granted, tone will sound three times and control will be in Program Mode A. Unmarked indicator light will illuminate.
6. Toggle to Program Mode B by pressing *Display On* pad. Unmarked indicator light is off.

EEPROM Update in Control Memory

EEPROM is permanent programmable memory of the control panel.

- Entry tone, door audio alarm and status are stored in EEPROM after control is deactivated.
- Information stored in EEPROM memory is not affected by power loss.

Mode A Function

Reading Temperature Display

Temperature display will show thermistor temperature in binary coded decimal format (BCD).

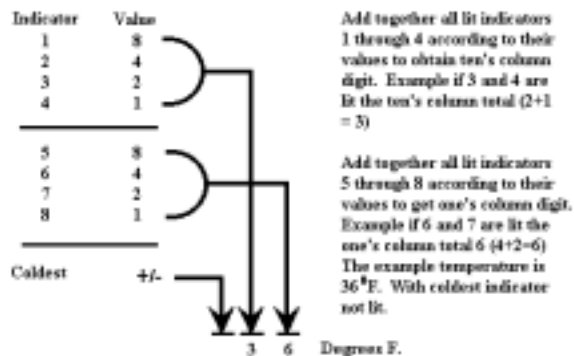

Indicator lights 1 through 4 represent the ten's digit with 1 being the most significant bit. Indicator lights 5 through 8 represent one's digit with 5 being the most significant bit. Positive and negative are shown by indicator light 9. Light glows to show negative value.

Freezer Thermistor Temperature

1. Choose freezer thermistor temperature display by pressing *Freezer Temp* pad.
2. Freezer thermistor temperature displays.

Refrigerator Thermistor Temperature

1. Choose refrigerator thermistor temperature display by pressing *Ref Temp* pad.
2. Refrigerator thermistor temperature displays.

Mode B Functions

Automatic Keyboard Functions

Activate and deactivate keyboard by toggling *Display Off* pad. If high temperature indicator glows, keyboard will disable after 10 minutes. If high temperature indicator is off, keyboard is always enabled. **DO NOT LEAVE KEYBOARD IN ENABLE MODE AFTER PROGRAMMING IS COMPLETE.**

Door Alarm Delay

1. Press *Alarm Off* pad. Door open indicator will glow. One temperature indicator should glow indicating present delay setting in minutes (indicator 1 means 1 minute, 2 means 2 minutes, etc.). Default delay is 3 minutes.
2. Press *Warmer* pad to decrease delay by 1 minute.
3. Press *Colder* pad to increase delay by 1 minute.

Max Ref Run Time Duration

1. Press *Max Ref* pad. Max Ref light will glow. One temperature indicator should glow indicating present Max Ref run time duration in 2 hour increments (indicator 1 means 2 hours, 2 means 4 hours, etc.). Default delay is 10 hours.
2. Press *Warmer* pad to decrease Max Ref duration by 2 hours.
3. Press *Colder* pad to increase Max Ref duration by 2 hours.

Program Mode

Max Frz Run Time Duration

1. Press *Max Frz* pad. Max Frz light will glow. One temperature indicator should glow indicating present Max Frz run time duration in 4 hour increments (indicator 1 means 4 hours, 2 means 8 hours, etc.) Default delay is 24 hours.
2. Press *Warmer* pad to decrease Max Frz duration by 4 hours.
3. Press *Colder* pad to increase Max Frz duration by 4 hours.

Temperature Offset Calibration

Offset amount adjusts temperatures for refrigerator cut-ins and cut-outs by the amount of offset. The chart below shows the indicator and the amount of offset from the factory default setting.

INDICATOR	OFFSET
1	+8
2	+6
3	+4
4	+2
5	+0
6	-2
7	-4
8	-6
Coldest	-8

- Setting refrigerator Temperature Offset. Press *Ref Temp* pad. Refrigerator indicator and one indicator will glow. Press *Warmer* pad to move offset to the next warmer setting. Press *Colder* pad to move to the next colder setting. Factory default refrigerator offset is +2.

- Setting Freezer Temperature Offset. Press *Freezer* pad. Freezer temperature indicator and one indicator will glow. Press *Warmer* pad to move offset to the next warmer setting. Press *Colder* pad to move offset to the next colder setting. Factory default freezer offset is 0.

Defrost Mode Selection

Toggle (*) pad to select adaptive or conventional defrost mode. Vacation indicator glows when adaptive defrost has been selected. If vacation indicator is off, conventional defrost is selected. Conventional defrost uses 8 hour CRDT value.

Forced Defrost

Defrost can be forced to start by pressing and holding the *Alarm Off* pad for 3 seconds. Program changes will be saved permanently in EEPROM and program mode will exit to Run Mode.

Forced Pull down (Compressor Start)

Compressor start can be forced by pressing and holding Max Frz for 3 seconds. Program changes will be saved permanently in EEPROM. Compressor, evaporator fan, damper heater, and condenser fan will come on.

Exiting Program Mode

Press *Display On* pad for 3 seconds to exit Program Mode. Tone will sound three times. Changes made in Program Mode will be permanently saved in EEPROM.

Note: If no pad is pressed for 10 minutes, Program Mode will be automatically exited. However, no changes will be saved if Program exits automatically.

Electronic Testing

Electronic Testing Mode

Forced Defrost Start

1. Press *Display On* pad to activate control panel.
2. Simultaneously press and hold Max Ref and *Display Off* pads for 3 seconds.

Forced Compressor Start

1. Press *Display On* pad to activate control panel.
2. Simultaneously press and hold Max Frz and *Display Off* pad for 3 seconds.

Open Thermistor Detect

Alarm sounds and freezer or refrigerator indicator light shows and temperature indicators 4 through 7 will turn on in sequence if either thermistor circuit opens. Refer to Temperature Control Operation Section and Electronic Testing Section.

1. Press Alarm Off pad to turn off alarm.
2. Alarm will retest for normal operation. If condition has not been corrected, alarm will sound again.

Evaporator Fan Suppression

The evaporator fan will turn off every time either refrigerator or freezer door is open.

To test if this function is operating:

1. Perform forced pull down procedure as noted above--evaporator fan should be on.
2. Open the refrigerator or freezer door--the fan should turn off.
3. Push the light switch off--the evaporator fan should start.

If fan does not toggle off and on when refrigerator light switch is turned off and on it has been determined evaporator fan motor operational, perform following tests to determine failure:



1. Check for line voltage on terminal E7 on high voltage board. With refrigerator door open (refrigerator light ON) reading should be 120-VAC. With door closed (refrigerator light OFF) reading should be approximately 0 VAC. If voltage does not change with light switch and light is turning light off and on red/white wire is broken between switch and high voltage board.
2. Check for voltage on terminal E7 on high voltage board. Output voltage should toggle with toggling of light switch. If it does not toggle, high voltage board needs replacing.
3. If terminal 7 on high voltage board changes with opening and closing of door, orange wire in low voltage harness is broken (check for continuity between pin 7 on high voltage board and pin 10 on low voltage board) or low voltage board needs replacing.



1. Check for line voltage on terminal E8 on high voltage board. With freezer door open, reading should be 120VAC. With door closed, reading should be approximately 0 VAC. If voltage does not change with light switch and light switch is turning light off and on, violet/white wire is broken between switch and high voltage board.
2. Check for voltage on pin 7 on pin connector of high voltage board. Output voltage should toggle with toggling of light switch. If it does not toggle, high voltage board needs replacing.
3. If voltage on pin 7 on pin connector on high voltage board changes with opening and closing of door, orange wire in low voltage harness is broken (check for continuity between pin 7 on high voltage pin connector and pin 10 on low voltage board) or low voltage board needs replacing.

Electronic Function Description

WARNING: To avoid electrical shock which can cause severe personal injury or death, disconnect power to refrigerator using power switch before servicing. Wires removed during disassembly must be replaced on proper terminals to insure earth ground and polarization. After servicing, reconnect power using power switch.

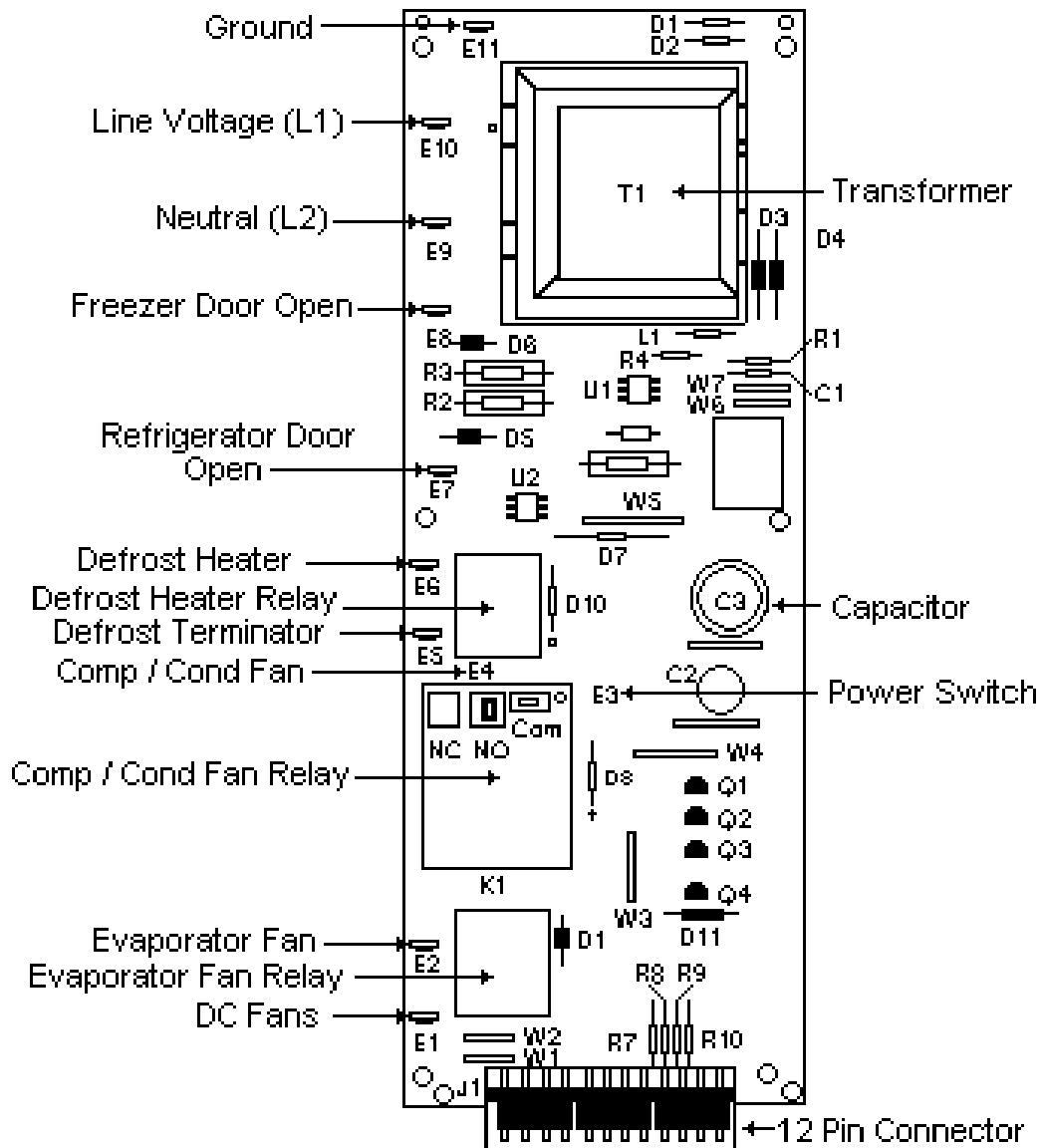

Electronic Function Description



WARNING

To avoid electrical shock which can cause severe personal injury or death, disconnect power to refrigerator using power switch before servicing. Wires removed during disassembly must be replaced on proper terminals to insure correct earth ground and polarization. After servicing, reconnect power using power switch

Refrigeration and Defrost Component Checks Made at High Voltage Board

Low voltage board input	W1 to D11 E10 to E9 (Neutral) or ground	approximately -25VDC approximately 120VDC
Compressor/condenser fan motor	“ON” = E4 to E9 (Neutral) or ground “OFF” = E4 to E9 (Neutral) or ground	approximately 120VDC
Compressor/condenser fan motor relay	“CLOSED” = R7 to ground “OPEN” = R7 to ground	approximately -11VDC approximately -25VDC
Evaporator fan motor relay	“CLOSED” = R8 to ground “OPEN” = R8 to ground	approximately -11VDC approximately -25VDC
Evaporator fan motor	“ON” =E2 (Neutral) or ground “OFF” = E2 (Neutral) or ground	approximately 120VDC 0VDC
Defrost heater	“ON” = E6 to E9 (Neutral) or ground “OFF” = E6 to E9 (Neutral) or ground	approximately 120VDC 0VDC
Defrost heater relay	“CLOSED” = R9 to ground “ OPEN” = R9 to ground	approximately -11VDC approximately -25VDC
Defrost terminator	“CLOSED” =E5 to E9 (Neutral) ground “OPEN” = E5 to E9 (Neutral) or ground	approximately 120VDC 0VDC
DC fan output voltage from high voltage board to fresh food fan or condensate evaporator fan	“ON” = E1 to ground “OFF” = E1 to ground	approximately -25VDC 0VDC
DC fan input voltage signal to high voltage board from low voltage board for fresh food fan and for condensate evaporator	“ON” =R10 to ground “OFF” = R10 to ground	approximately -11VDC approximately -25VDC

Filament voltage at pin 11 and 12 = less than 5VDC

Wiring Diagram



WARNING To avoid electrical shock which can cause severe personal injury or death, disconnect power to refrigerator using power switch before servicing. Wires removed during disassembly must be replaced on proper terminals to insure correct earth ground and polarization. After servicing, reconnect power using power switch.

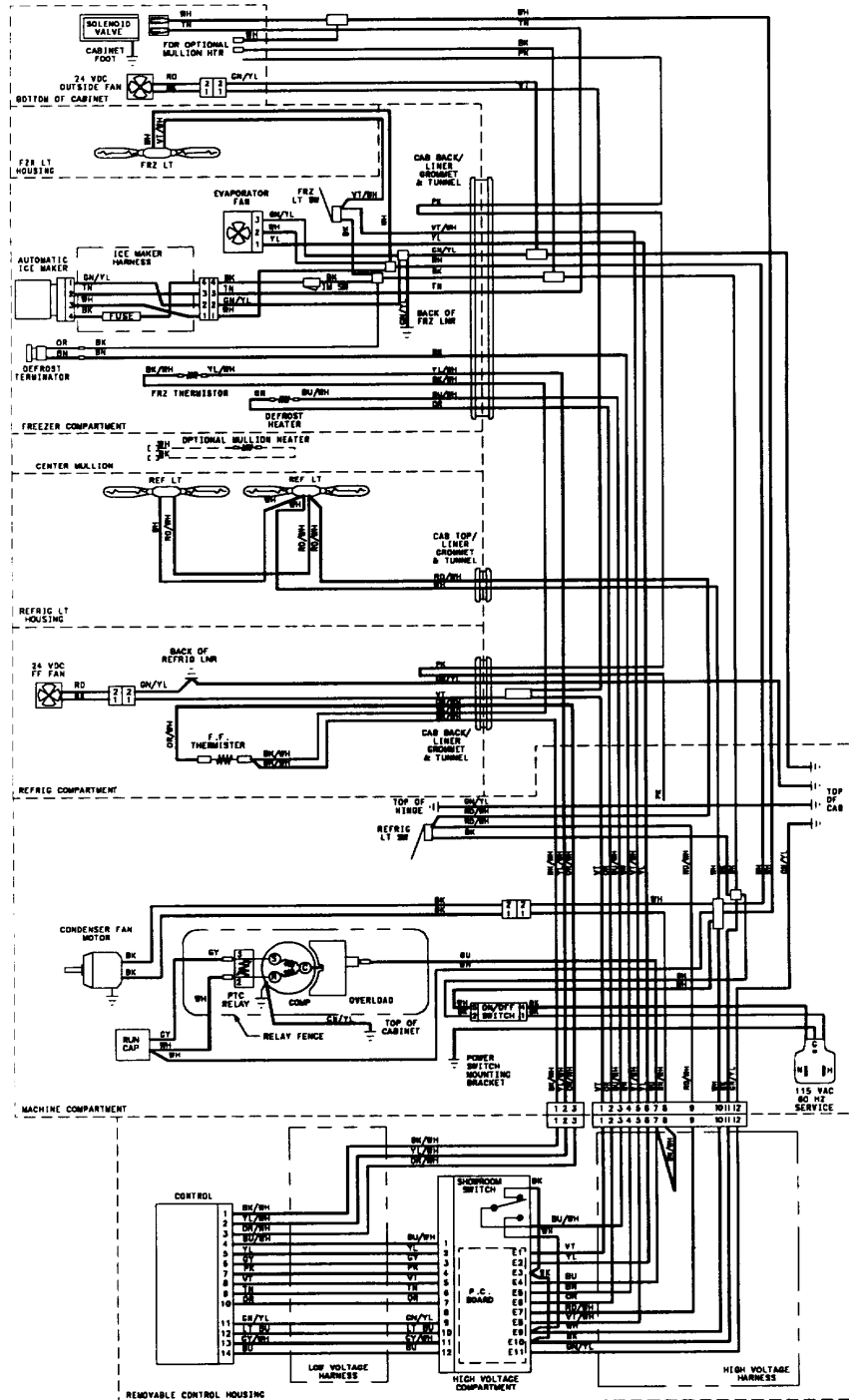

Wiring Schematic



To avoid electrical shock which can cause severe personal injury or death, disconnect power to refrigerator using power switch before servicing. Wires removed during disassembly must be replaced on proper terminals to insure correct earth ground and polarization. After servicing, reconnect power using power switch

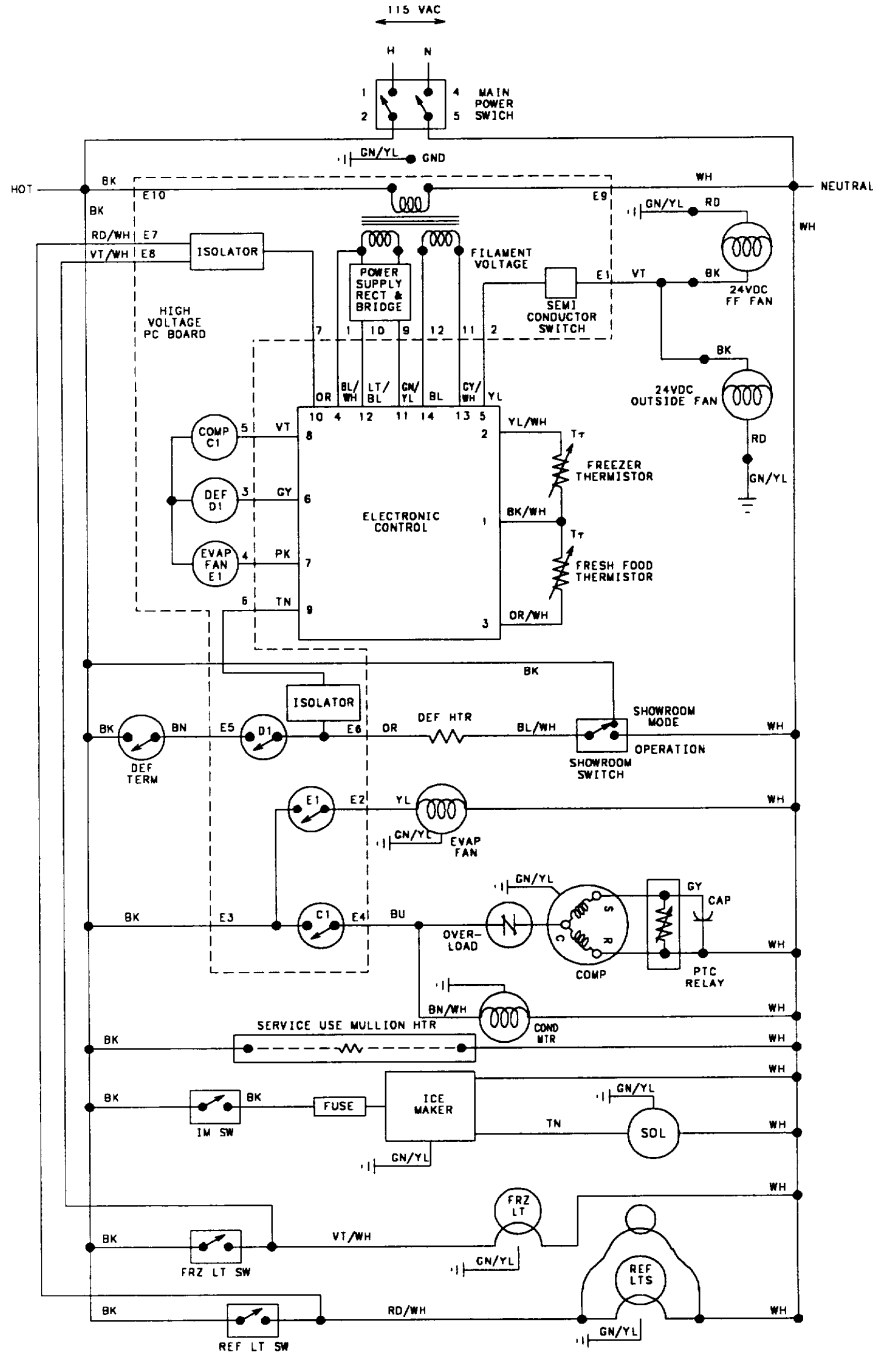

Electronic Function Description



WARNING: To avoid electrical shock which can cause severe personal injury or death, disconnect power to refrigerator using power switch before servicing. Wires removed during disassembly must be replaced on proper terminals to insure correct grounding and polarization. After servicing, reconnect power using power switch.

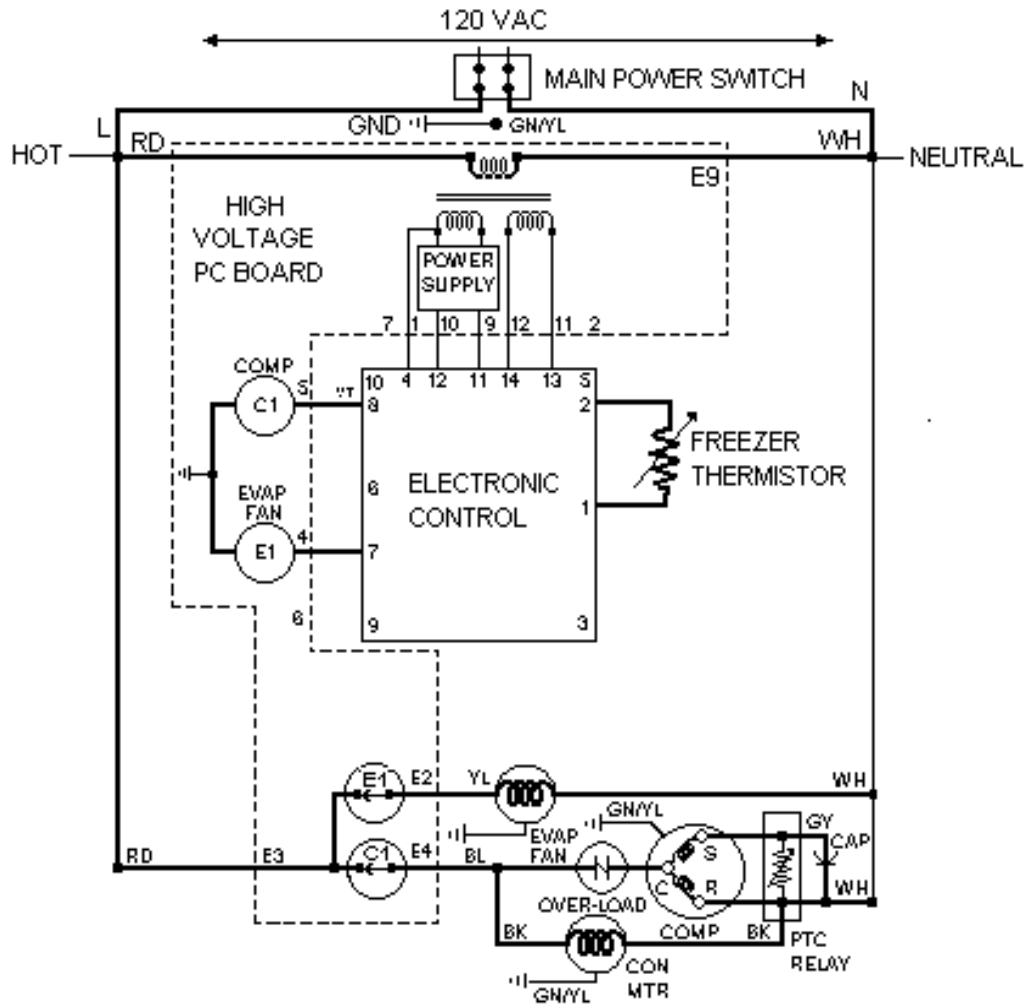

Freezer Compartment Theory of Operation

As a freezer thermistor warms, the resistance decreases allowing low voltage signal to be sent to electronic control. Electronic control sends two low voltage signals, one to the compressor relay coil (C1) and one to the evaporator relay coil (E1).

When both relay coils are energized and both relay contacts are closed, high voltage circuits to evaporator fan motor and compressor / condenser fan motor are complete.

As thermistor cools during refrigeration cycle, resistance through thermistor increases blocking low voltage signal to electronic control interrupting circuit.

Electronic Function Description



WARNING: To avoid electrical shock which can cause severe personal injury or death, disconnect power to refrigerator using power switch before servicing. Wires removed during disassembly must be replaced on proper terminals to insure correct grounding and polarization. After servicing, reconnect power using power switch.

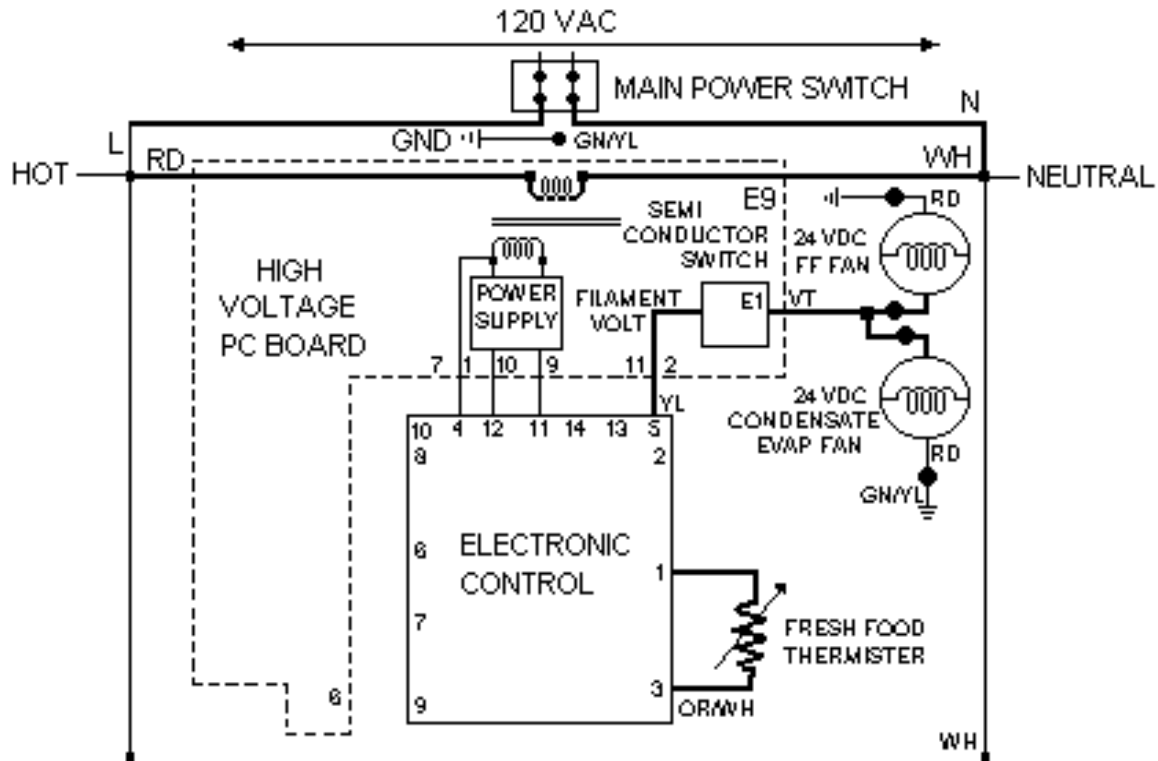

Refrigeration Compartment Theory of Operation

As fresh food thermistor warms, resistance decreases allowing low voltage signal to be sent to the electronic control. Electronic control sends a low voltage signal, to semiconductor switch for DC fresh food fan and DC condensate evaporator fan.

Both fans begin operating. Fresh food fan circulates freezer air into fresh food compartment. Condensate evaporator fan circulates air over condensate drain pan aiding in evaporation.

As fresh food thermistor cools, resistance increases blocking low voltage signal to electronic control interrupting circuit to DC fresh food fan and DC condensate evaporation fan.

Electronic Function Description



WARNING: To avoid electrical shock which can cause severe personal injury or death, disconnect power to refrigerator using power switch before servicing. Wires removed during disassembly must be replaced on proper terminals to insure correct grounding and polarization. After servicing, reconnect power using power switch.

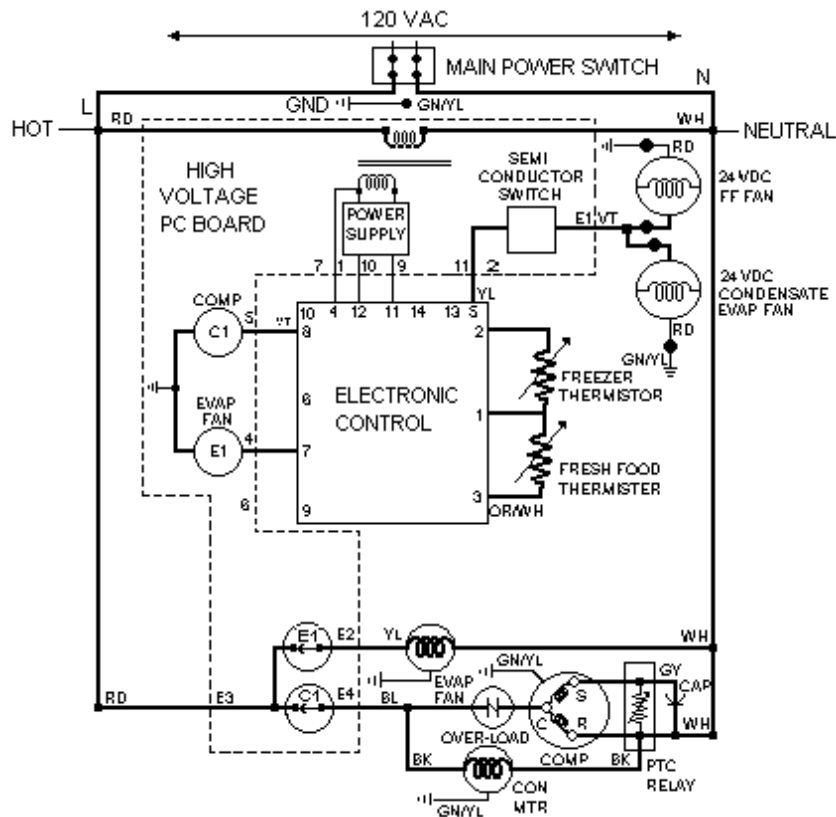

Refrigerator and Freezer Compartment Theory of Operation

If both freezer and fresh food thermistors are warm, their resistance drops (see table Refrigerator and Freezer Thermistor in Temperature Control Section) and the electronic signals for compressor / condenser fan motor operation and for operation of fresh food and condensate evaporator fans.

After freezer thermistor cools sufficiently to raise resistance and block the signal to the electronic control, compressor / condenser fan motor will shut off.

However, fresh food and condensate evaporator fans will continue to run until fresh food thermistor cools and signal is blocked to electronic control.

If fresh food thermistor cools before freezer thermistor, electronic control will interrupt circuit to fresh food and condensate evaporator fans while evaporator fan motor will continue to operate under control of freezer thermistor.

Electronic Function Description



WARNING: To avoid electrical shock which can cause severe personal injury or death, disconnect power to refrigerator using power switch before servicing. Wires removed during disassembly must be replaced on proper terminals to insure correct grounding and polarization. After servicing, reconnect power using power switch.

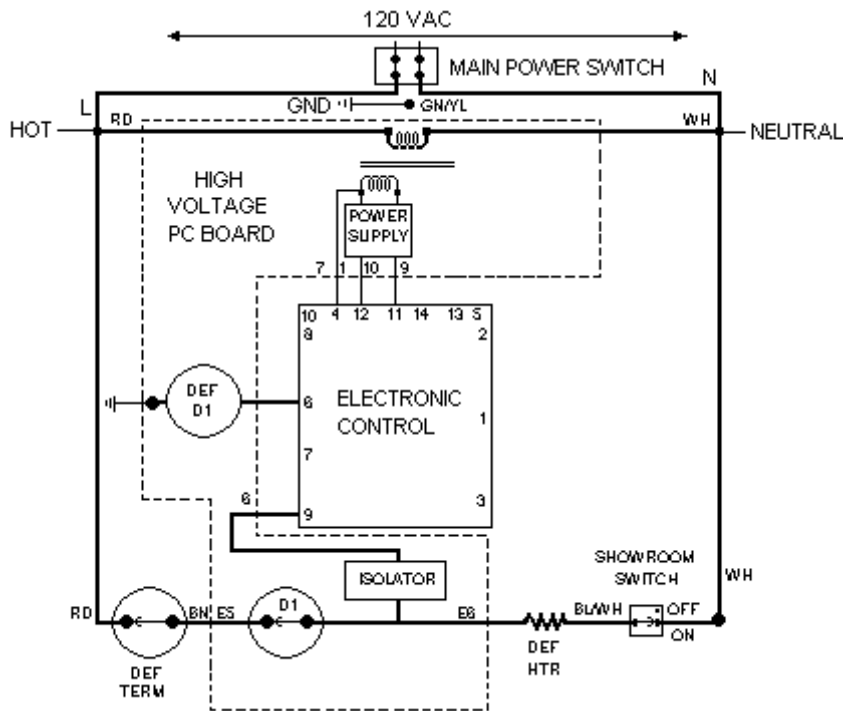

IMPORTANT: When the showroom switch is OFF, the isolator sees line voltage which keeps the electronic controller from signaling the evaporator fan motor or compressor relay coils and also keeps the fresh food and condensate evaporation fans off.

Adaptive Defrost Theory of Operation

After designated compressor run time, refrigeration cycle is interrupted and electronic control sends a low voltage signal to defrost relay coil (def D1).

Powering the relay coil closes contact (D1) completing high voltage circuit to defrost heater through closed defrost terminator (closes at 15 F).



Isolator, which is part of high voltage PC board, recognizes presence of line voltage to defrost heater and sends low voltage signal to electronic control.

Electronic control keeps count of number of minutes, defrost terminator remains closed (opens at 48 F).

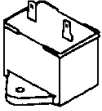
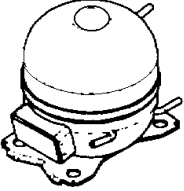

Length of time defrost terminator is closed determines if the next defrost cycle advances by 4 hours of compressor run, stays at the same interval, or delays by 4 hours of compressor run.

If defrost terminator does not open before 29 minutes, defrost cycle is automatically terminated by electronic control and refrigeration cycles will resume after 6 minutes dwell time.



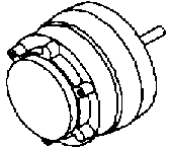
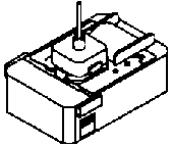
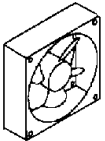
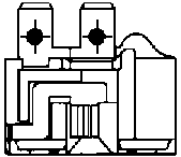
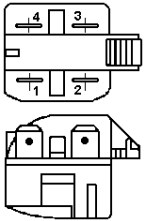
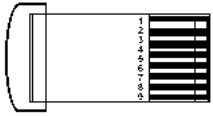
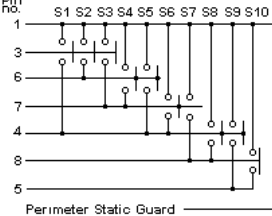

Component Specifications

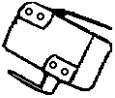
Component	Description	Test Procedures
	Bulb	Volts 120VAC Watts 40 watts
	Capacitor, compressor run	Volts 220VAC Capacitance 15 μ fc + 10% - 5%
	Compressor Type	Fan cooled, R134a refrigerant BTUH 970 BTUH Volts 120VAC 60Hz Watt 176 watts Current: Lock rotor 21.3 A Full load 1.6 A Resistance: Run windings 2.60 Ω Start windings 4.35 Ω
	Drier	Drier must be changed every time the system is opened for testing or compressor replacement. Desiccant (20) 8x12.4AXH – 7 M. S.-Grams
	Heater, evaporator	Volt 120VAC Wattage 450 \pm 5% W Resistance 30 \pm 5% Ω
	Heater, Mullion For service use only, foamed in place. Not powered from the factory.	Volt 120VAC Wattage 20Watts Resistance 661 \pm 7.5 Ω <div style="border: 1px solid black; padding: 5px; margin: 10px 0;"> <p style="text-align: center;"> WARNING</p> <p>To avoid risk of electrical shock which can cause death or severe injury, disconnect electrical power to unit before servicing.</p> </div> <p>To connect mullion heater to power:</p> <ol style="list-style-type: none"> 1. Disconnect power to unit using power switch. 2. Remove toe grille. Locate water valve wiring harness. 3. Carefully, slit wiring harness vinyl sleeve to expose one black and one white lead bent with bullet terminators. 4. Locate mullion heater leads at the left side of cabinet and connect to black and white leads. 5. Wrap vinyl sleeve with electrical tape to close slit.
	High voltage circuit board P.C.	See “Electronic Functional Description”.
	Low voltage circuit board	See “Electronic Functional Testing”.

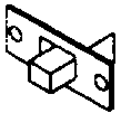

Component Specifications

	<p>Motor, condenser PSC</p>	<p>Volt Rotation (facing end opposite shaft) RPM Watt Current Resistance</p>	<p>120 VAC Clockwise 1300 RPM 6.4 Watts 0.05 Amp 480 Ω</p>																				
	<p>Motor, ECM evaporator fan.</p>	<p>Volt Rotation (facing shaft) RPM Watt</p>	<p>120VAC Counterclockwise 2150 RPM 1.4 Watts</p>																				
	<p>Motor and blade, Refrigerator, condenser, evaporator fan.</p>	<p>Volt Rotation (facing shaft) RPM Watt</p>	<p>120VAC Counterclockwise 3300 RPM 1.4 Watts</p>																				
	<p>Overload</p>	<p>Volt Ult. Trip amps @158°F (70°C) Close temperature Open temperature Short time trip (seconds) Short time trip (amps @ 77°F (925°C)</p>	<p>120VAC 3.51 Amps 142°F (61°C) ± 9° 257°F (125°C) ± 5° 10 seconds 14 amps.</p>																				
	<p>Relay</p>	<p>Resistance with power off check across terminals 2 & 3. Shorted Open</p>	<p>3 – 12 Ω 0 Ω very high or infinite ohms.</p>																				
<div style="display: flex; align-items: center;"> <div style="flex: 1;"> <p>Switch Keyboard</p>  </div> <div style="flex: 2;"> <table border="1"> <thead> <tr> <th>Switch Functions</th> <th>Pin no.</th> </tr> </thead> <tbody> <tr> <td>Display On</td> <td>1</td> </tr> <tr> <td>Freezer Temperature</td> <td>3</td> </tr> <tr> <td>Refrigerator Temperature</td> <td>6</td> </tr> <tr> <td>Warmer</td> <td>7</td> </tr> <tr> <td>Colder</td> <td>4</td> </tr> <tr> <td>Max Cool</td> <td>8</td> </tr> <tr> <td>Fast Freeze</td> <td>5</td> </tr> <tr> <td>Alarm Off</td> <td>9</td> </tr> <tr> <td>Display Off</td> <td>10</td> </tr> </tbody> </table> </div> <div style="flex: 1;">  </div> </div>				Switch Functions	Pin no.	Display On	1	Freezer Temperature	3	Refrigerator Temperature	6	Warmer	7	Colder	4	Max Cool	8	Fast Freeze	5	Alarm Off	9	Display Off	10
Switch Functions	Pin no.																						
Display On	1																						
Freezer Temperature	3																						
Refrigerator Temperature	6																						
Warmer	7																						
Colder	4																						
Max Cool	8																						
Fast Freeze	5																						
Alarm Off	9																						
Display Off	10																						
	<p>Switch, auger</p>	<p>Type Volts Current</p>	<p>DPST, NO 250 / 125 VAC 10 / 5 Amp.</p>																				
	<p>Switch, refrigerator light (left opening door hinge)</p>	<p>Type Volt Current</p>	<p>SPST, NC 125 / 25 VAC 3 Amps.</p>																				

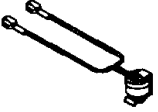
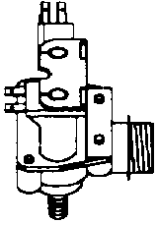
Component Specifications

	Switch, refrigerator light (Right opening door hinge)	Type Volt Current	SPST, NC 125 / 250 VAC 3 Amps
	Switch, power	Type Volt Current	DPST 125 / 250 VAC 15 Amps
	Switch, freezer light, sealed	Type Volt Current	SPST, NC 125 / 250 VAC 5.0 Amps.
	Switch, showroom	Type Volt Current	SPDT 125VAC 6 Amps
	Thermister	Check resistance across Terminals. Bell curve Resistance (see page 13) @77°F @45°F	30,000 ohms ± 1% ohms 68,000 ohms ± 2% ohms
	Thermostat	Volt Watt Current Resistance across terminals Above 55°F ± 6°F Below 20°F ± 8°F Between 55°F ± 6°F And 20°F ± 8°F	120VAC 1000 Watts 10 Amps Open Closed Will stay in current state (either Open or closed) until either 55°F ± 6°F and 20°F ± 8°F is reached.
	Valve, water	Volt Watt Water pressure (inlet) Max Min Fill rate	120VAC, 60Hz. 20 Watts 120psi 20psi 140 ± 10 CC's at 7.5 seconds.

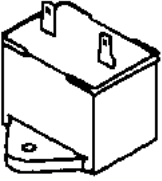
Component Testing

Component	Description	Testing
<p>Capacitor</p> 	<p>Run capacitor connects to relay terminals 3 and L2 side of line.</p>	<div style="border: 1px solid black; padding: 5px; margin-bottom: 10px;">  <p>WARNING</p> <p>To avoid electrical shock which can cause severe personal injury or death, discharge capacitor through a resistor before handling</p> </div> <ol style="list-style-type: none"> 1. Disconnect power to refrigerator 2. Remove captor cover and disconnect capacitor wires. 3. Discharge capacitor be shorting across terminals with a resistor for 1 minute. 4. Check resistance across capacitor terminals with ohmmeter set on “Rx1K “scale. <ul style="list-style-type: none"> • Good—needle swings to 0 ohms and slowly moves back to infinity. • Open—needle does not move. Replace capacitor • Shorted—needle moves to zero and stays. replace capacitor. • High resistance leak—needle jumps toward 0 and then moves back to constant high resistance (not infinity)
<p>Capillary tube</p>	<p>Capillary is sized in diameter, and length to feed proper amount refrigerant to evaporator.</p> <p>Capillary is soldered to suction line to transfer heat from capillary and add additional superheat to gas refrigerant in compressor suction line.</p>	<p>Restricted or clogged capillary tube must be replaced with tube of same inner diameter and length.</p>

Component Testing

Component	Description	Test Procedures
Compressor	<p>When compressor electrical circuit is energized, the start winding current causes relay to heat. After an amount of starting time, start winding circuit turns off. Relay will switch off start winding circuit even though compressor has not started (for example, when attempting to restart after momentary power interruption).</p> <p>With “open” relay, compressor will not start because there is little or no current to start windings. Overload protection will open due to high locked rotor run winding current.</p> <p>With “shorted” relay or capacitor, compressor will start and overload Protector will quickly open due to high current of combined run and start windings.</p> <p>With open or weak capacitor, compressor will start and run as normal but will consume more energy.</p>	<p>Resistance test</p> <ol style="list-style-type: none"> 1. Disconnect power to unit. 2. Discharge capacitor by shorting across terminals with a resistor for 1 minute. 3. Remove leads from compressor terminals. 4. Set ohmmeter to lowest scale. 5. Check for resistance between Terminals “S” and “C” Terminals “R” and “C” <p>If either compressor winding reads open (infinite or very high resistance) or dead short (0 ohms), replace compressor.</p> <p>Ground Test</p> <ol style="list-style-type: none"> 1. Disconnect power to refrigerator. 2. Discharge capacitor by shorting terminals through a resistor for 1 minute. 3. Remove compressor leads and use an ohmmeter set on highest scale. 4. Touch one lead to compressor body (clean point of contact and the other probe to each compressor terminal. If a reading is obtained, compressor is grounded and must be <p>Operation Test</p> <p>If voltage, capacitor, overload, and motor winding test good, perform the following test.</p> <ol style="list-style-type: none"> 1. Disconnect power to refrigerator using power switch. 2. Discharge capacitor by shorting capacitor terminals through a resistor for 1 minute. 3. Remove leads from compressor terminals. 4. Wire a test cord to power switch. 5. Place time delayed fuse with UL rating equal to amp rating of motor in test cord socket. 6. Remove overload and relay. 7. Connect start, common and run leads of test cord on appropriate terminals of compressor. 8. Attach capacitor leads of test cord together. If capacitor is used, attach capacitor to a known good capacitor of

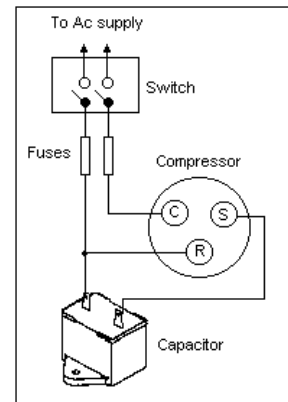

Component Testing

Compressor	Description	Test Procedure
		<p>9. Plug test cord into volt-watt meter to determine start and run wattage as well as check for low voltage which can also be a Source of trouble.</p> <p>10. With power to voltmeter, press start cord switch and release.</p> <ul style="list-style-type: none"> • If compressor motor start and draws normal wattage, compressor is okay and trouble is in capacitor, relay / overload, freezer temperature control , or elsewhere in system. • If compressor does not start when direct wired, recover system at high side. After system is recovered, repeat compressor direct wire test. If compressor runs after recovery, a restriction is indicated. • If compressor does not run when wired direct after recovery <u>replace faulty compressor.</u>
<p>Condenser</p>	<p>Condenser is of tube and wire Construction located in Compressor compartment</p> <p>Condenser is on high pressure discharge side of compressor transfer heat absorbed by refrigerant to ambient.</p> <p>Higher pressure gas is routed to condenser where, as gas temperature is reduced, gas condenses into a high pressure liquid state. Heat transfer takes place because discharge gas is at a higher temperature than air that is passing over condenser. It is very important that adequate air flow over condenser is maintained.</p> <p>Condenser is air cooled by Condenser fan motor. If efficiency of heat transfer from condenser to surrounding air is impaired, condensing temperature becomes higher. High liquid temperature means the liquid will not remove as much heat during boiling in evaporator as under normal head pressure, long run time, and high wattage.</p> <p>From compressor refrigerant Flows into serpentine under Condensate pan to help evaporate condensate, and then into pre-condenser loop which helps control exterior condensation on flange, center mullion, and around freezer door.</p>	<p>Leaks in condenser can usually be determined by using an electronic or soap solution. Look for signs of compressor oil when checking for leaks. A certain amount of compressor oil is circulated with refrigerant.</p> <p>Leaks in post condenser loop are rare because loop is a one-piece copper tube except for brazed joint visible in machine.</p> <p>For Minute Leaks:</p> <ol style="list-style-type: none"> 1. Separate condenser from rest of refrigeration system and pressurize condenser up to a maximum of 9.65 bars (140psi) with a refrigerant and dry nitrogen combination. 2. Recheck for leaks. <div style="text-align: center; margin: 10px 0;">  <p>WARNING</p> </div> <p>To avoid severe personal injury or death from sudden eruption of high pressure gases, observe the following:</p> <ul style="list-style-type: none"> • Protect against a sudden eruption if high pressure are required for leak checking. • Do not use high pressure compressed gases in refrigeration systems without a reliable pressure regulator and pressure relief valve in the lines.

Component Testing

Compressor	Description	Test Procedure
	<p>From condenser refrigerant flows into capillary and then to evaporator before returning to compressor through suction line.</p>	
	<p>Drier is placed at post condenser loop outlet and passes liquefied refrigerant to capillary. Desiccant (20) 8x12 4AXH-7 M.S. Grams.</p>	<p>Drier must be changed every time the system is opened for testing or compressor replacement. NOTE: Drier used in R12 sealed system is not interchangeable with drier used in R134a sealed system.</p> <p>Before opening refrigeration system, recover HFC 134a refrigerant for safe disposal.</p> <ol style="list-style-type: none"> 1. Score capillary tube close to drier and break. 2. Reform inlet tube to drier allowing enough space for large tube cutter. <p style="text-align: center;">CAUTION</p> <p>To avoid death or severe personal injury, cut drier at correct location. Cutting drier at incorrect location will allow desiccant beads to scatter. If spilled, completely clean area of beads</p> <ol style="list-style-type: none"> 3. Cut circumference of drier 1/4" below condenser inlet tube joint to drier. 4. Remove drier. 5. Apply heat trap paste on post condenser tubes to protect grommets from high heat. 6. Unbrazed remaining part of drier. Remove drier from system. 7. Discard drier in safe place. Do not leave drier with customer. If refrigerator is under warranty, old drier must accompany warranty claim.
	<p>Evaporator</p> <p>Inner volume of evaporator allows liquefied refrigerant discharged from capillary to expand into refrigerant gas.</p> <p>Expansion cools evaporate tube and fin temperature to approximately -20°F transferring heat from freezer section to refrigerator.</p> <p>Passing through suction line to compressor, the refrigerant picks up superheat (a relationship between pressure and temperature that assures complete vaporization of liquid refrigerant) as result of capillary in suction line.</p>	<p>Test for leaks in evaporator with electronic leak detector or with soap solution. Compressor oil is circulated with refrigerant, check for oil when checking for leaks. NOTE: Follow all procedures for recovering R134a Refrigerant for safe disposal when opening system. For Minute Leaks.</p> <p style="text-align: center;">WARNING</p> <p>To avoid severe personal injury or death from eruption of high pressure gasses, observe the following:</p> <ol style="list-style-type: none"> 1. Protect against a sudden eruption if high pressures are required for leak checking. 2. Do not use high pressure compressed gasses in refrigeration systems without a reliable pressure regulator and pressure relief valve in the line.

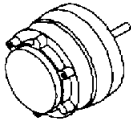
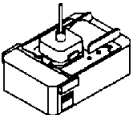

Component Testing

Compressor	Description	Test Procedure
	Refrigerant gas is pulled through suction line by compressor to complete the refrigerant cycle.	<ol style="list-style-type: none"> 1. Separate evaporator from rest of refrigeration system and pressurize evaporator up to a maximum of 235 PSI with a refrigerant and dry nitrogen combination. 2. Recheck for leaks.
Heater, cavity	Applied to back of ice and water cavity to help prevent condensation from forming on face of cavity. Wire in series with hot side of line through auger motor interlock switch.	<p>Check resistance across heater.</p> <p>If heater is faulty, use spare heater foamed in place at factory.</p>
Heater, evaporator (defrost)	See "Electronic Function Description, Adaptive Defrost Circuitry."	<p>Check resistance across heater.</p> <p>To check defrost system:</p> <ol style="list-style-type: none"> 1. Thermocouple defrost thermostat and plug refrigerator into wattmeter. 2. Force into defrost mode (see section on electronic testing) Wattmeter should read specified watts (according to Technical Data Sheet) ± 5 F; thermostat should interrupt power to heater
Heater mullion	<p>For service use only to reduce condensation on center mullion.</p> <p>Heater formed in place. Not powered from the factory.</p>	<p>⚠ WARNING To avoid risk of electrical shock, personal injury, or death, disconnect power to unit before servicing.</p> <p>To connect mullion heater to power:</p> <ol style="list-style-type: none"> 1. Disconnect power to unit using power switch. 2. Remove ice grille. 3. Remove bracket holding condenser evaporation fan and water valve. 4. Locate water valve wiring harness. 5. Carefully slit wiring harness vinyl sleeve to expose one black and one white lead with bullet terminals inside harness sleeve. 6. Connect to heater leads at left side of cabinet. 7. Wrap vinyl sleeve with electrical tape to close slit.
Icemaker	See "icemaker" section for service information.	
Motor Condenser 	Condenser fan moves cooling air across condenser coil and compressor body.	Check resistance across motor windings
Motor Evaporator 	Evaporator motor moves air across evaporator coil.	<ol style="list-style-type: none"> 1. Disconnect power to unit. 2. Disconnect fan motor leads. 3. Check resistance from ground connection solder. Trace to motor frame must not exceed .05 ohms. 4. Check for voltage at connection to motor.

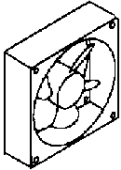
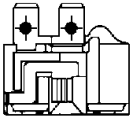
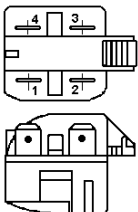

Component Testing

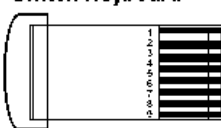
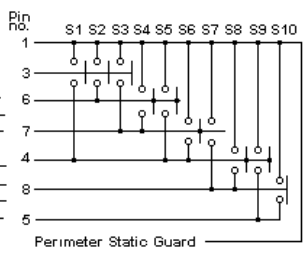
Compressor	Description	Test Procedure
<p>Motor, DC</p> 	<p>Refrigerator fan circulates cold air into refrigerator</p> <p>Condensate evaporation fan and out through toe grille to assure complete condensate evaporation.</p> <p>DC fan motors are connected in series with semiconductor switch.</p>	<p>See Refrigeration and Defrost Component Checks Made at High Voltage Board. For DC fan voltage check procedures at High Voltage Board.</p> <p>Check for voltage across terminals.</p>
<p>Overload / Relay</p> 	<p>Overload is a temperature and current sensing device.</p> <p>Overload opened when high current or high compressor temperature is sensed.</p> <p>After overload opens, reset can require up to two hours depending on ambient temperature and residual heat load in compressor.</p>	<ol style="list-style-type: none"> 1. Disconnect power to the refrigerator. 2. Remove relay cover and pull relay off compressor. Pull overload protector off compressor common terminal. 3. With ohmmeter, check the resistance between male terminal and female pin receptacle terminal which pushes onto Compressor common terminal. At ambient room temperature Overload protector should have less than 1 ohm resistance. An open overload protector will have infinite resistance. <p>Relay (See PTC Relay).</p>
<p>Relay, PTC</p> 	<p>When voltage is connected and relay is cool, current passed through relay to start winding. After a short time, current heats the resistor in relay and resistance will rise blocking current flow through relay. start winding remains in the circuit through run capacitor.</p> <p>Solid state relay plugs directly on compressor start and run terminals. Relay terminals 2 and 3 are connected within relay. Run capacitor is connected to relay terminals 3. L2 side of the 120 VAC power is connected to relay terminal 2.</p>	<p>With power off check resistance across terminals 2 and 3. Refer to Technical Data Sheet for values for model being serviced.</p>

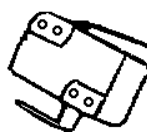
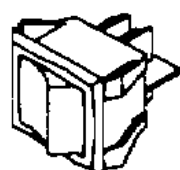
Component Testing

Compressor	Description	Test Procedure											
Switch, keyboard	<p>Semiconductor Switch for control panel keyboard Electronic control is not repairable. If any component is faulty, entire control must be replaced.</p> <p>NOTE: Repair or replaced line voltage components before testing or replacing electronic control. Do not assume problems are caused by electronic control system. Opened, shorted, grounded or otherwise faulty line voltage components (including power cord and wiring) can create problems that appear to be caused by electronic control.</p>	<div style="display: flex; align-items: flex-start;"> <div style="margin-right: 20px;">  <p>Switch Keyboard</p> </div> <table border="1" style="font-size: small;"> <tr><th>Switch Functions</th></tr> <tr><td>Display On</td></tr> <tr><td>Freezer Temperature</td></tr> <tr><td>Refrigerator Temperature</td></tr> <tr><td>Warmer</td></tr> <tr><td>Colder</td></tr> <tr><td>*</td></tr> <tr><td>Max Cool</td></tr> <tr><td>Fast Freeze</td></tr> <tr><td>Alarm Off</td></tr> <tr><td>Display Off</td></tr> </table> <div style="margin-left: 20px;">  </div> </div>	Switch Functions	Display On	Freezer Temperature	Refrigerator Temperature	Warmer	Colder	*	Max Cool	Fast Freeze	Alarm Off	Display Off
Switch Functions													
Display On													
Freezer Temperature													
Refrigerator Temperature													
Warmer													
Colder													
*													
Max Cool													
Fast Freeze													
Alarm Off													
Display Off													
	Interrupts connection to ice maker when freezer door is open .	Check resistance across terminals. Switch arm depressed closed Switch arm not depressed open											
	Completes circuit to allow indicated function. See tech sheet and wiring diagram for individual switch.	Check resistance across terminals. Switch arm down "NC" terminals closed "NO" terminals open Switch arm up "NC" terminals open "NO" terminals closed											
	Disconnect all power to unit when switch is OFF (open) Unit shipped with switch ON.	Check resistance across terminals Switch OFF (open) No continuity between 1&2, 4&5 Switch ON (closed) continuity between 1&2, 4&5											

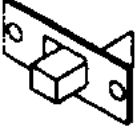
Component Testing

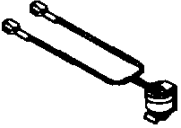
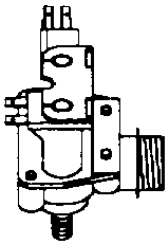
Compressor	Description	Test Procedure
<p>Switch, showroom SPDT</p> 	<p>ON position completes circuit to lights and display only</p> <p>OFF position completes circuit for normal operation.</p> <p>Unit shipped with switch in OFF position.</p>	<p>Check resistance at test points.</p> <p>Showroom operation –E3 at high voltage board to pin 3 (blue/white wire) at high voltage wire harness.</p> <p>Unit run—E9 at high voltage board to pin 3 (blue/white wire) at high voltage wire harness.</p>
<p>Thermistor</p> 	<p>Senses temperature within Refrigerator and freezer.</p>	<p>Check resistance across terminals. See Technical Date Sheet for bell curve resistance chart at given temperature.</p>
<p>Thermostat</p> 	<p>Thermostat is in a series circuit with high voltage board and defrost heater.</p> <p>Controls the circuit through defrost terminator to defrost heater. Opens and breaks circuit when thermostat senses present high voltage.</p> <p>After defrost thermostat opens thermostat remains open until end of defrost cycle and refrigerator starts cooling again. When defrost thermostat senses a preset low temperature and closes.</p>	<p>With power off and evaporator coil below freezing thermostat should check continuous when checked with ohmmeter. See “Heater, evaporator (defrost)” section for additional tests.</p>
<p>Valve, water</p> 	<p>controls water flow to the ice Maker.</p>	<p>Check resistance across coil windings. See Technical Data Sheet for valves for model being serviced.</p>

Troubleshooting Guide

Symptom	Possible Causes	Corrective Action
Unit does not run	No power to unit	Check for power at outlet. Check fuse box / circuit breaker for blown fuse or tripped breaker. Replace or reset.
	Faulty service cord	Check with test light at unit, if no circuit and current is indicated at outlet, replace or repair.
	Low voltage	Check input voltage for proper voltage. Take appropriate action to correct voltage supply problem.
	Freezer temperature set too warm	Adjust freezer temperature.
	Faulty timer	Check with test light. Replace if necessary.
	Faulty relay	Check relay. Replace if necessary.
	Faulty compressor	Check compressor motor windings for opens / shorts. Perform compressor direct wiring test. Replace if necessary.
	Faulty overload	Check overload for continuity. NOTE: Ensure compressor / overload are below trip temperature before testing. Replace if necessary.
Refrigerator section too warm	Excessive door opening	Consumer education.
	Overloading of shelves	Consumer education.
	Warm or hot foods placed in cabinet	Consumer education.
	Refrigerator temperature set too warm.	Adjust refrigerator temperature.
	Poor door seal	Level cabinet. Adjust hinges. Replace gasket.
	Dirty condenser	Clean condenser.
	Refrigerator airflow	Check airflow grille for obstructions. Adjust as necessary. Check airflow fan. Replace if faulty.
	Interior light remains on	Check switch. Replace if necessary.
	Faulty condenser fan or evaporator fan	Check fan switch, fan, and wiring. Replace if necessary.
	Faulty compressor	Check intake valve. Replace compressor.
Refrigerator section too cold	Refrigerator temperature set too cold.	Adjust refrigerator temperature.
	Refrigerator airflow not properly adjusted	Adjust airflow grille to freezer. Adjust Chef's pantry temperature control.
Refrigerator section too cold	Refrigerator temperature set too cold	Adjust refrigerator temperature.
	Refrigerator airflow not properly adjusted.	Adjust airflow grille to freezer. Adjust Chef's pantry temperature control.
Freezer section too cold	Freezer temperature set too cold	Adjust freezer temperature.
Unit runs continuously	Temperature set too cold	Adjust temperature.
	Dirty condenser or obstructed grille	Check condenser and grille. Clean.
	Poor door seal	Level cabinet. Adjust hinges. Replace gasket.
	Interior light remains on	Check switch. Replace if necessary.
	Faulty condenser fan or evaporator fan	Check fan switch, fan, and wiring. Replace if necessary.
	Refrigerant shortage or restriction	Check for leak or restriction. Repair, evacuate and recharge system.

Filename: VCB36034.doc
Directory: D:\VBCODE\IPLUTILS\PDFGenerator\InputData\F90574 TechVCBB360-362
Template: C:\Documents and Settings\tomw.EYECOM\Application
Data\Microsoft\Templates\Normal.dot
Title: Troubleshooting Guide
Subject:
Author: Viking Range
Keywords:
Comments:
Creation Date: 3/21/2002 3:59 PM
Change Number: 3
Last Saved On: 3/28/2003 4:35 PM
Last Saved By: Ken Sievert
Total Editing Time: 1 Minute
Last Printed On: 3/28/2003 7:16 PM
As of Last Complete Printing
Number of Pages: 1
Number of Words: 403 (approx.)
Number of Characters: 2,299 (approx.)