

*TECHNICIAN TESTED*

# TECHNIQUES

BY

Viking Preferred Service

## TECH – NOTES

VCSB481 / VCSB482

BUILT –IN REFRIGERATOR

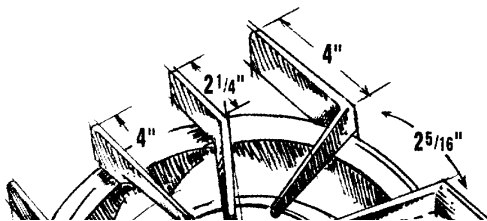

**VIKING**<sup>®</sup>  
Preferred Service

## TECHNICAL INFORMATION

- Due to a possibility of personal injury or property damage, always contact an authorized technician for servicing or repair of this refrigerator.
- Refer to Service Manual for design, disassemble, ice maker, safety, testing, and troubleshooting information.



To avoid electrical shock which can cause severe personal injury or death, disconnect power to the refrigerator using power switch before servicing. Wires removed during disassembly must be replaced on proper terminals to insure correct earthing and polarization. After servicing, reconnect power using power switch.

<b>Model</b>	<b>VCSB481SS</b>
<b>Capacity</b>	<b>28.57 cu. ft.</b>
<b>Electrical Requirements</b>	<b>120 VAC 60 Hz</b>
<b>Separate Circuit</b>	<b>15 Amp</b>
<b>Refrigerant type</b>	<b>134A</b>
<b>Width</b>	<b>47 1/2"</b>
<b>Depth Without Handle</b>	<b>24"</b>
<b>Includes Door Extrusions</b>	
<b>Height Range Rollers to Top</b>	<b>83 1/4" - 84"</b>

No Load Performance Controls in Normal Position					
	<b>Kw /24 hr ±0.4</b>	<b>Percent Run Time ±10%</b>	<b>Cycles / 24hr ±25%</b>	<b>Refrigerator Center Compartment Food Average Temperature</b>	<b>Freezer Compartment Food Average Temperature ±3°F</b>

Temperature Relationship Test Chart						
	<b>T-1 Outlet ±3°F</b>	<b>T-2 Inlet ±3°F</b>	<b>T-3 Suction Line ±7°F</b>	<b>Average Total Wattage ±10%</b>	<b>Suction Pressure ±2 PSIG</b>	<b>Head Pressure ±5 PSIG</b>
<b>Ambient</b>	<b>65° 110°</b>	<b>65° 110°</b>	<b>65° 110°</b>	<b>65° 110°</b>	<b>65° 110°</b>	<b>65°      110°</b>

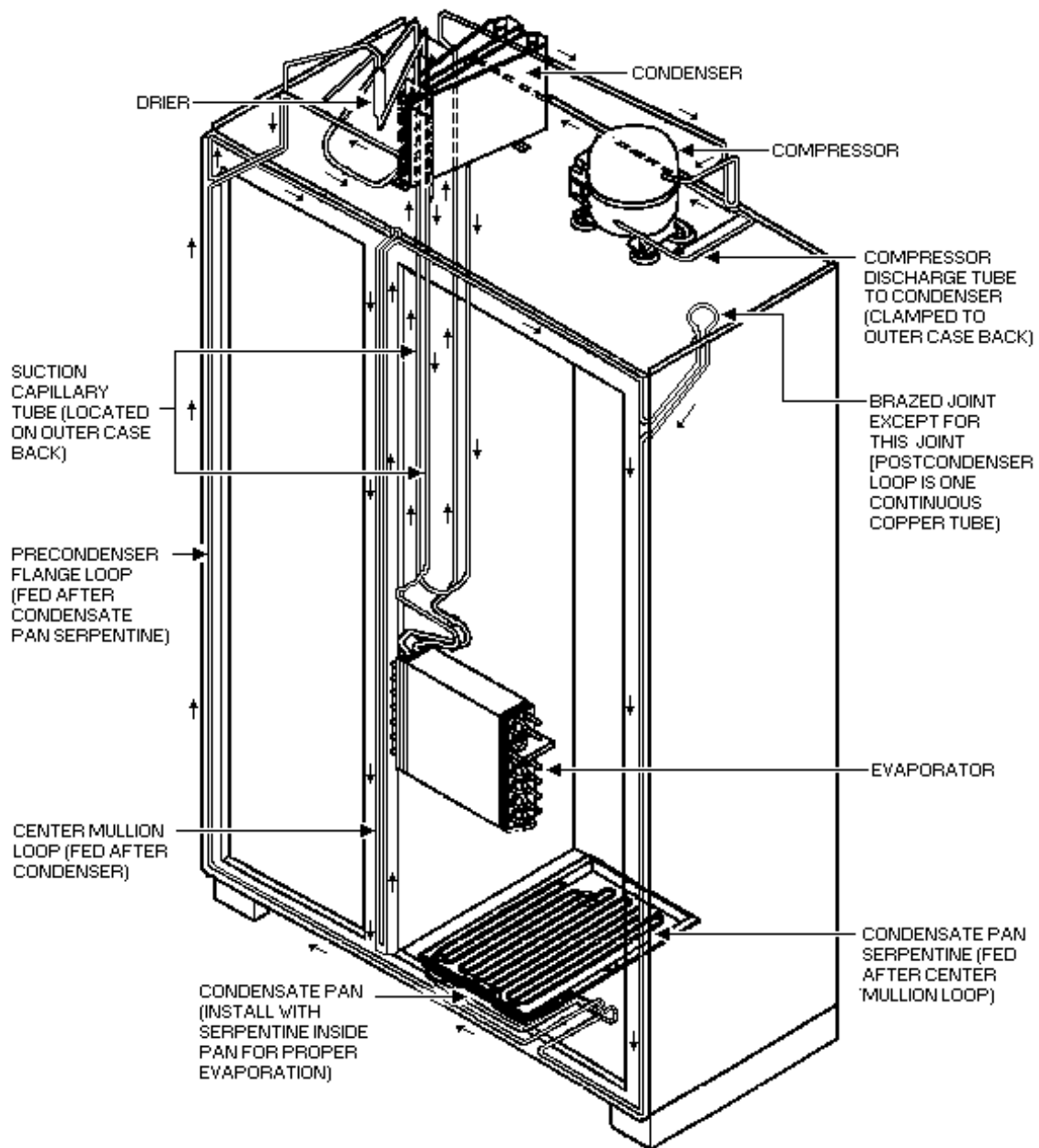



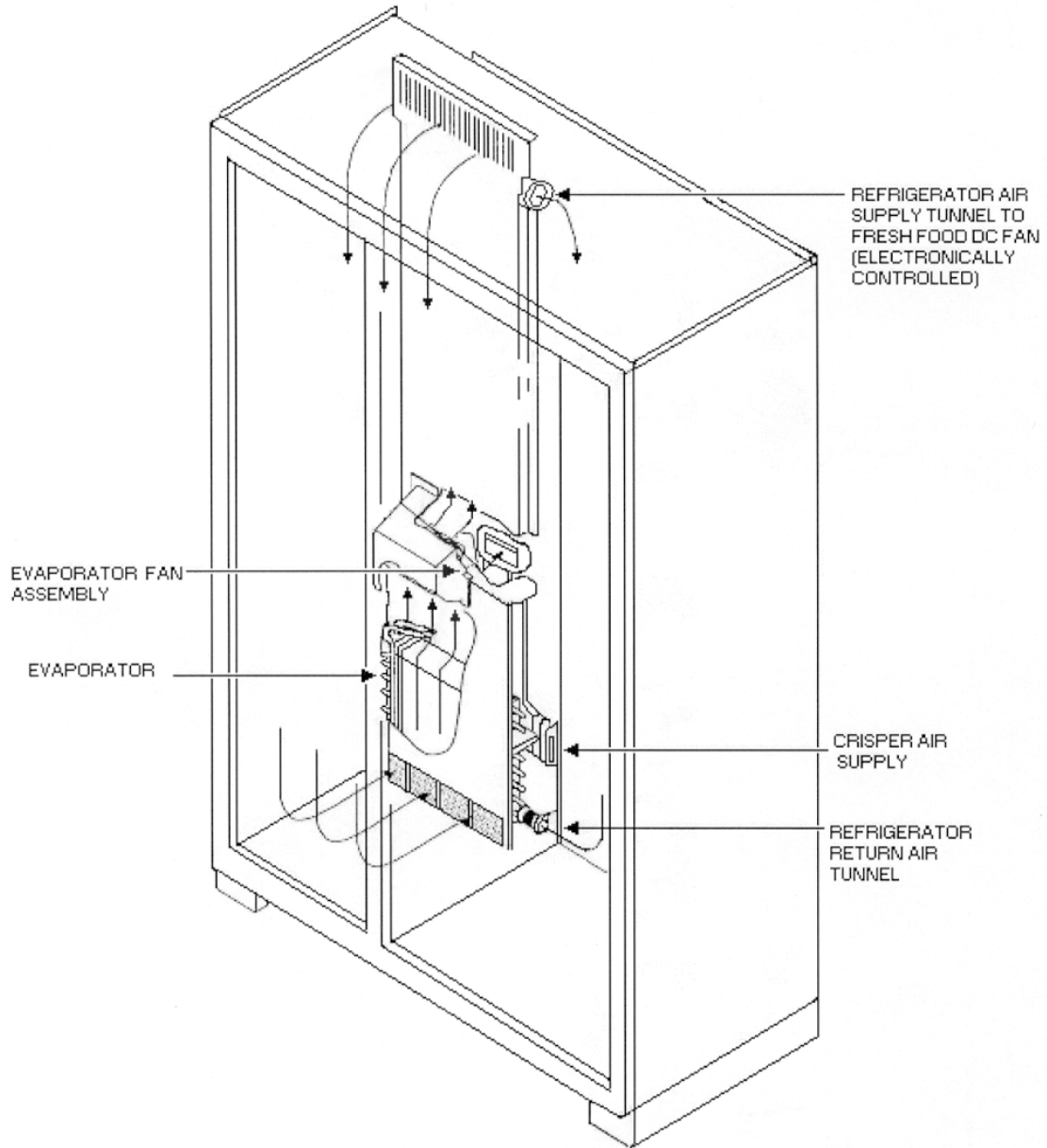

## CABINET AIR FLOW

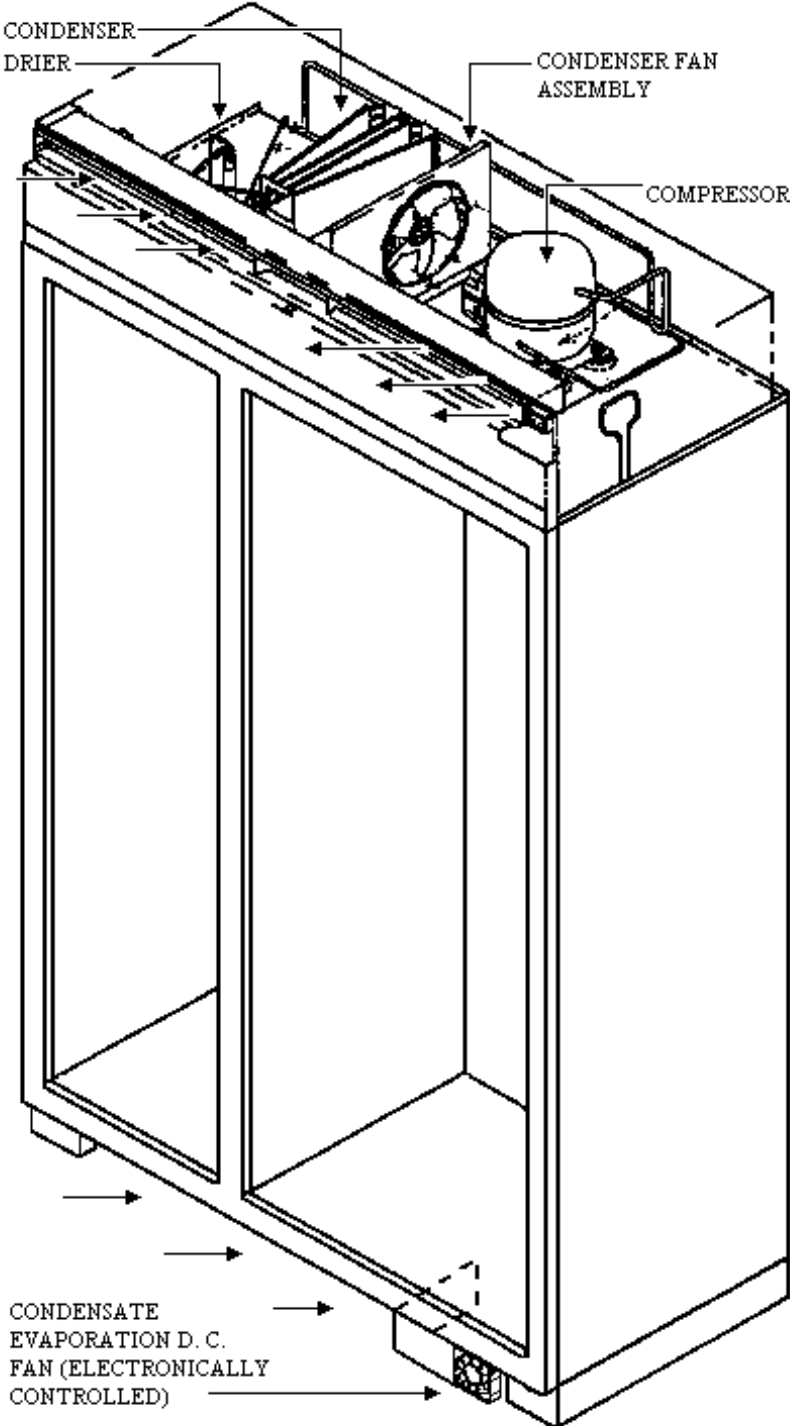



MACHINE COMPARTMENT AIR FLOW

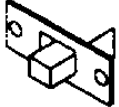

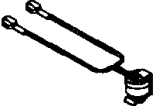
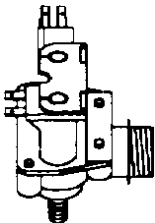

### Component Specifications

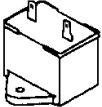
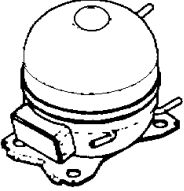
	Switch, refrigerator light (Right opening door hinge)	Type Volt Current	SPST, NC 125 / 250 VAC 3 Amps
	Switch, power	Type Volt Current	DPST 125 / 250 VAC 15 Amps
	Switch, freezer light, sealed	Type Volt Current	SPST, NC 125 / 250 VAC 5.0 Amps.
	Switch, showroom	Type Volt Current	SPDT 125VAC 6 Amps
	Thermister	Check resistance across Terminals. Bell curve Resistance (see page 13) @77°F @45°F	30,000 ohms ± 1% ohms 68,000 ohms ± 2% ohms
	Thermostat	Volt Watt Current Resistance across terminals Above 55°F ± 6°F Below 20°F ± 8°F Between 55°F ± 6°F And 20°F ± 8°F	120VAC 1000 Watts 10 Amps  Open Closed  Will stay in current state (either Open or closed) until either 55°F ± 6°F and 20°F ± 8°F is reached.
	Valve, water	Volt Watt Water pressure (inlet) Max Min Fill rate	120VAC, 60Hz. 20 Watts  120psi 20psi 140 ± 10 CC's at 7.5 seconds.

### Component Specifications

Component	Description	Test Procedures
	Bulb	Volts 120VAC Watts 40 watts
	Capacitor, compressor run	Volts 220VAC Capacitance 15 $\mu$ fc + 10% - 5%
	Compressor Type	Fan cooled, R134a refrigerant BTUH 970 BTUH Volts 120VAC 60Hz Watt 176 watts Current: Lock rotor 21.3 A Full load 1.6 A Resistance: Run windings 2.60 $\Omega$ Start windings 4.35 $\Omega$
	Drier	Drier must be changed every time the system is opened for testing or compressor replacement.  Desiccant (20) 8x12.4AXH – 7 M. S.-Grams
	Heater, evaporator	Volt 120VAC Wattage 450 $\pm$ 5% W Resistance 30 $\pm$ 5% $\Omega$

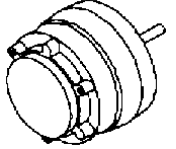
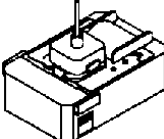
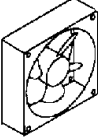
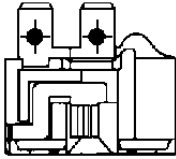
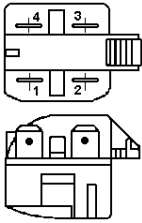
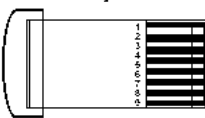
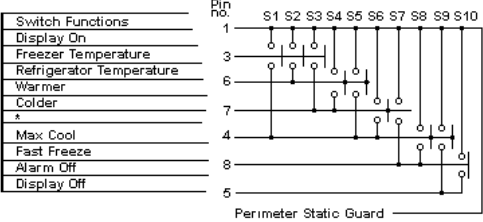
## Component Specifications

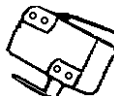
	<p>Motor, condenser PSC</p>	<p>Volt Rotation (facing end opposite shaft) RPM Watt Current Resistance</p>	<p>120 VAC Clockwise 1300 RPM 6.4 Watts 0.05 Amp 480 Ω</p>																						
	<p>Motor, ECM evaporator fan.</p>	<p>Volt Rotation (facing shaft) RPM Watt</p>	<p>120VAC Counterclockwise 2150 RPM 1.4 Watts</p>																						
	<p>Motor and blade, Refrigerator, condenser, evaporator fan.</p>	<p>Volt Rotation (facing shaft) RPM Watt</p>	<p>120VAC Counterclockwise 3300 RPM 1.4 Watts</p>																						
	<p>Overload</p>	<p>Volt Ult. Trip amps @158°F (70°C) Close temperature Open temperature Short time trip (seconds) Short time trip (amps @ 77°F (925°C)</p>	<p>120VAC 3.51 Amps 142°F (61°C) ± 9° 257°F (125°C) ± 5° 10 seconds 14 amps.</p>																						
	<p>Relay</p>	<p>Resistance with power off check across terminals 2 &amp; 3.  Shorted Open</p>	<p>3 – 12 Ω  0 Ω very high or infinite ohms.</p>																						
<div style="display: flex; align-items: center;"> <div style="flex: 1;"> <p><b>Switch Keyboard</b></p>  </div> <div style="flex: 2;"> <table border="1"> <thead> <tr> <th>Switch Functions</th> <th>Pin no.</th> </tr> </thead> <tbody> <tr><td>Display On</td><td>1</td></tr> <tr><td>Freezer Temperature</td><td>2</td></tr> <tr><td>Refrigerator Temperature</td><td>3</td></tr> <tr><td>Warmer</td><td>4</td></tr> <tr><td>Colder</td><td>5</td></tr> <tr><td>Max Cool</td><td>6</td></tr> <tr><td>Fast Freeze</td><td>7</td></tr> <tr><td>Alarm Off</td><td>8</td></tr> <tr><td>Display Off</td><td>9</td></tr> <tr><td>Perimeter Static Guard</td><td>10</td></tr> </tbody> </table> </div> <div style="flex: 1;">  </div> </div>				Switch Functions	Pin no.	Display On	1	Freezer Temperature	2	Refrigerator Temperature	3	Warmer	4	Colder	5	Max Cool	6	Fast Freeze	7	Alarm Off	8	Display Off	9	Perimeter Static Guard	10
Switch Functions	Pin no.																								
Display On	1																								
Freezer Temperature	2																								
Refrigerator Temperature	3																								
Warmer	4																								
Colder	5																								
Max Cool	6																								
Fast Freeze	7																								
Alarm Off	8																								
Display Off	9																								
Perimeter Static Guard	10																								
	<p>Switch, auger</p>	<p>Type Volts Current</p>	<p>DPST, NO 250 / 125 VAC 10 / 5 Amp.</p>																						
	<p>Switch, refrigerator light (left opening door hinge)</p>	<p>Type Volt Current</p>	<p>SPST, NC 125 / 25 VAC 3 Amps.</p>																						



## DISPLAY PANEL KEYBOARD

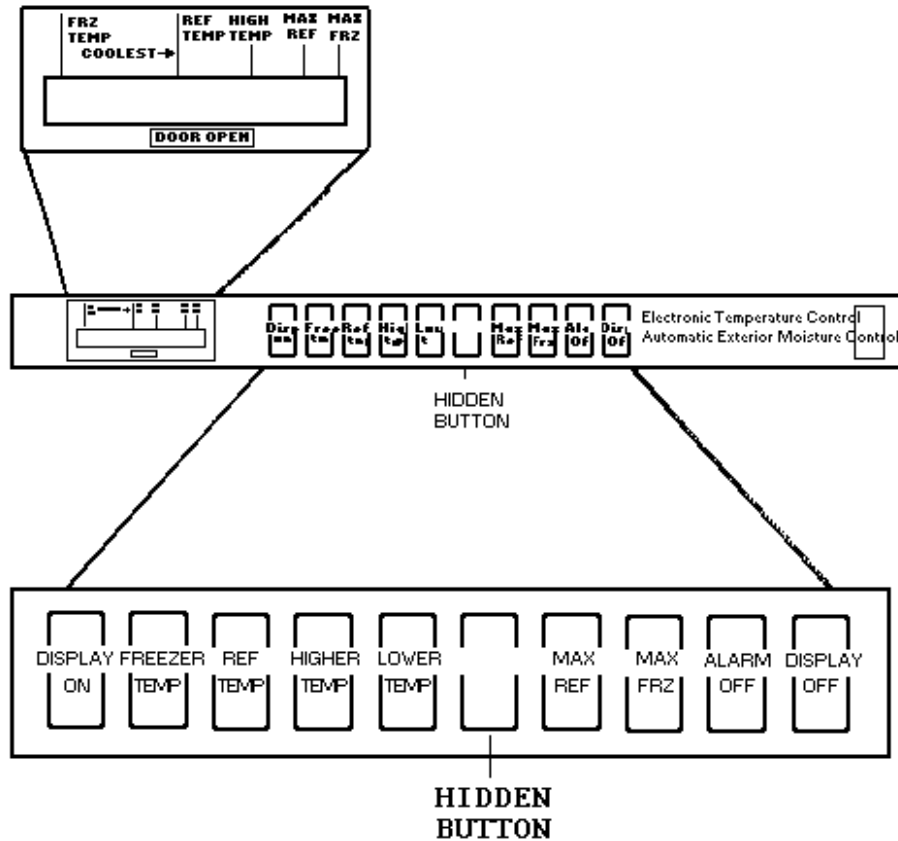

### Display Panel Operation

#### Keyboard Pad Functions

##### Entry Tone

Indicates a pad was pressed, command read and accepted. Turn off entry tone by pressing and holding Display On pad for 3 to 5 seconds.

##### Command Accepted Tone

Three short tones indicate command accepted.

##### Display On Pad

1. Activates control panel. Control panel remains active at least 10 minutes.
2. Turns off Power Up Alarm (flashing lights) after power is first plugged in or after power outage.

**Note:** All pads, except Alarm Off, are inactive until Display On is pressed.

##### Freezer Temp Pad

Activates freezer temperature setting mode.

1. Freezer indicator light will glow. Freezer temperature setting will be displayed. Factory setting is 5.
2. Change freezer temperature setting by pressing Higher Temp or Lower Temp Pad.

##### Ref Temp Pad

Activates refrigerator temperature setting mode.

1. Refrigerator indicator light will glow. Refrigerator temperature setting will be displayed. Factory setting is 5.
2. Change refrigerator temperature setting by pressing Higher Temp or Lower Temp Pad.

##### Higher Temp Pad

Raises temperature setting one bar at a time. If entry tone is on. Tone will sound at each bar level until top level is reached.

1. Turn on temperature setting function of control panel by pressing Higher Temp Pad.
2. Press and hold Higher Temp pad to raise temperature setting at a faster rate.

## Display Panel Operation (con't)

### Lower Temp Pad

Lowers temperatures setting one bar at a time. If entry tone is on, tone will sound at each bar level until bottom level is reached.

1. Turn on temperature setting function of control panel by pressing Lower Temp Pad.
2. Press and hold Lower Temp Pad to lower temperature setting at a faster rate.

### Max Frz Pad

Activates Maximum freezer mode setting freezer temperature to coldest setting for 24 hours or until Max Frz pad is pressed again.

1. Freezer indicator light will glow.
2. To adjust maximum freezer mode time refer to Program Mode B functions.

### Max Ref Pad

Activates Maximum refrigerator mode setting refrigerator to coldest setting for 24 hours or until Max Ref Pad is pressed again.

1. Refrigerator indicator light will glow.
2. To adjust maximum refrigerator time refer to Mode B functions.

### Alarm Off Pad

Turns off alarm signals. See Alarms section to interpret alarm signals.

1. Press and hold Alarm Off pad for 3 seconds to deactivate Door Open alarm. To reactivate Door Open alarm, press and hold Alarm Off pad for 3 seconds.
2. If Alarm Off pad is pressed and condition causing alarm is not corrected, alarm will reset.

### Hidden Button

Activates Program Mode. See Program Mode section for description of functions available.

1. Open refrigerator door.
2. Press Display On pad.
3. Press hidden button pad.
4. Within 6 seconds press the following pads in this sequence: Max Ref, Max Frz, Max Ref, Max Frz.
5. Tone will sound 3 times and control will be in program mode A.

### Display Off Pad

1. Deactivates control panel.
2. Deactivates temperature indication area of control panel.

## Electronic Functional Description

### Power Disconnect Switch

Use power disconnect switch to disconnect power without unplugging refrigerator. Power disconnect switch is located behind air grille on top right side. Refrigerator is shipped with power disconnect switch in the On position.

### Showroom Switch

Showroom switch allows electronic controls and interior lights to function independently of refrigeration system. Showroom switch is located behind air grill to right of control panel. Refrigerator is shipped with showroom switch in unit run position.

## Alarms

### Power Up Alarm

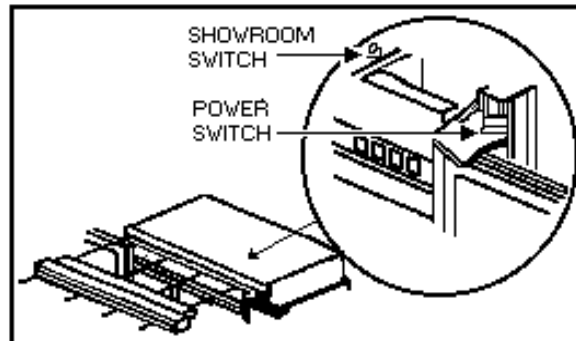

After power is initially plugged in, after a power loss, or if power switch is turned off, all temperature indicator lights will flash until Alarm Off or Display On is pressed.

**Note:** All settings return to default factory settings.

### Door Open Alarm

Alarm tone sounds and indicator lights blink if either refrigerator or freezer door is open more than 3 minutes.

1. Turn off Door Open alarm by pressing Alarm Off pad or by closing door.
2. Deactivate door open alarm by pressing Display On pad and then press and hold Alarm Off pad for 3 seconds.
3. Door alarm delay can be adjusted in Program Mode B.

### High Temperature Alarm

Alarm sounds and indicator light shows if freezer or refrigerator temperature has gone above critical level and remained warm for 2 hours. Alarm tone stops if temperature falls again.

**Electronic Functional Description (con't)**

1. Critical temperature for freezer is +15° F; for refrigerator critical temperature is +60° F.
2. Press Alarm Off pad to turn off alarm.

**Thermistor Alarm**

Alarm sounds and freezer or refrigerator indicator light shows and temperature indicators 4 through 7 will turn on in sequence if either thermistor circuit opens. Refer to Temperature Control Operation Section and Electronic Testing Section.

1. Press Alarm Off pad to turn off alarm.
2. Alarm will retest for normal operation. If condition has not been corrected, alarm will sound again.

**Temperature Control Operation**

For any temperature setting, outputs will be turned off/on based on cut-in/cut-out temperature determined by resistance levels of freezer and refrigerator thermistors.

**Refrigerator and Freezer Thermistor**

Temp °F (C)	Resistance Ohms	Temp °F (C)	Resistance Ohms
-20 (-29)	495600	36 (2)	87510
-15 (-26)	418200	38 (3)	82740
-9 (-23)	354000	39 (4)	78300
-6 (-21)	300600	43 (6)	74100
-4 (-18)	256200	45 (7)	70170
5 (-15)	218850	46 (8)	66450
10 (-12)	187470	48 (9)	62970
16 (-9)	161040	50 (10)	59670
19 (-7)	138690	55 (13)	52290
25 (-4)	119760	61 (16)	45900
30 (-1)	103680	64 (18)	40410
32 (0)	97920	70 (21)	36540
34 (1)	92550	77 (25)	30000

**As temperature decreases, resistance increases.  
As temperature increases, resistance decreases.**

Open thermistor or thermistor circuit will result in failure of refrigerator to cool.

Shorted thermistor will cause refrigerator to run 100 percent of time except for defrost cycle.

- Freezer temperature setting and thermistor value will determine if compressor/condenser fan and evaporator fan switches are open or closed. Compressor/condenser fan switch must be open for 6 minutes before switch can close again (compressor dwell time).
- Refrigerator temperature setting and thermistor value will determine if fresh food fan switch is open or closed.
- Cut-out and cut-in temperature values must be reached and maintained for 15 seconds before output state will change (digital delay).
- Refrigerator and freezer control calibration can be adjusted in Program Mode B.

**Factory set freezer and refrigerator settings**

Frozen Food		Fresh Food		Level
Cut-Out °F (C) +1.5	Cut-in °F (C) +1.5	Cut-Out °F (C) +1.5	Cut-in °F (C) +1.5	
-10 (-23)	2 (-17)	29 (-2)	34 (1.1)	9
-8 (-22)	4 (-16)	31 (-0.6)	36 (2.2)	8
-6 (-21)	6 (-14)	33 (-0.6)	38 (3.3)	7
-5 (-21)	7 (-14)	34 ( 1 )	39 (3.9)	6
-4 (-20)	8 (-13)	35 ( 2 )	40 (4.4)	5
-3 (-19)	9 (-13)	36 ( 2 )	41 ( 5 )	4
-2 (-19)	10 (-12)	37 ( 3 )	42 (5.5)	3
0 (-18)	12 (-11)	39 ( 4 )	44 (6.6)	2
2 (-17)	14 (-10)	41 ( 5 )	46 (7.7)	1
-10 (-23)	2 (-17)	----	----	Max Ref
----	----	29 (-2)	44 (6.6)	Max Frz

## Electronic Functional Description (con't)

### Adaptive Defrost Operation

Defrost occurs after predetermined length of compressor run hours. Compressor run time between defrosts changes, or adapts, depending upon recent history of defrost lengths (time it takes for defrost terminator to open after defrost heater has been turned on).

- Defrost terminator opens at 55° F (13° C) and closes at 20° F (-7° C).
- Compressor run time between defrost (CRTD) will be one of 3 values under normal operation: CRTD 1 (8 hours) or CRTD 2 (12 hours) or CRTD 3 (16 hours).

If defrost length is low (DT-LO defined as 21 minutes) indicating small frost load, CRTD for next defrost cycle is advanced to next level.

If defrost length is high (DI-HI defined as 24 minutes) indicating large frost load, CRTD for next defrost cycle is lowered to next level.

If defrost length is between 21 and 24 minutes, CRTD for next defrost cycle remains the same.

Initial value at power up CRTD 0 is 4 hours.

- Hidden Button Mode CRTD equals 96 hours. Hidden Button Mode CRTD is interrupted with door openings. Defrost interval will revert back to interval before Hidden Button Mode. Three things must occur to reach Hidden Button Mode CRTD:
  1. Defrost interval must be CRTD 3 (16 hours).
  2. Both refrigerator and freezer doors must have remained closed since last defrost cycle.
  3. Defrost thermostat must have opened in less than 21 minutes during last defrost cycle.
- Six minutes dwell time occurs after defrost terminator opens before compressor and condenser fan motor will operate. Ten minute dwell time occurs after defrost terminator opens before evaporator fan motor will operate. Dwell time can be bypassed by disconnecting power to the unit for 30 seconds.
- Conventional defrost can be selected in Program Mode B.

## PROGRAM MODE

### Accessing Program Mode

Two programming modes are available. Mode A allows reading refrigerator and freezer thermistor temperatures. Mode B is used for all other programmable functions.

1. Open refrigerator door.
2. Press Display On pad.
3. Press Hidden Button pad.
4. Press the following sequence of pads within 6 seconds; Max Ref, Max Frz, Max Ref, Max frz.\
5. When access is granted, tone will sound three times and control will be in Program Mode A. unmarked indicator light will illuminate.
6. Toggle to Program Mode B be pressing Display On pad. Unmarked indicator light is off.

### EEPRM Update in Control Memory

EEPRM is permanent programmable memory of the control pane..

- Entry tone, door audio alarm and status are stored in EEPRM after control panel is deactivated.
- Information stored in EEPRM memory is not affected by power loss.

### Mode A Functions

#### Reading Temperature Display

Temperature display will show thermistor temperature in binary coded decimal format (BCD). Indicator lights 1 through 4 represent the tens digit with 1 being the most significant bit. Indicator lights 5 through 8 represent ones digit with 5 being the most significant bit. Positive and negative are shown be indicator light 9; light glows to show negative value.

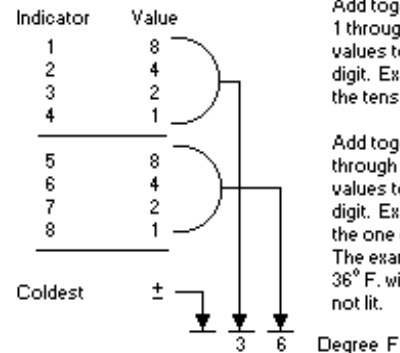

Add together all lit indicators 1 through 4 according to their values to obtain ten's column digit. Example if 3 and 4 are lit the tens column total 3 (2+1=3)

Add together all lit indicators 5 through 8 according to their values to get one's column digit. Example if 6 and 7 are lit the one column total 6 (4+2=6). The example temperature is 36° F, with coldest indicator not lit.

## Mode A Functions (con't)

### Freezer Thermistor Temperature

1. Choose freezer thermistor temperature display by pressing Freezer Temp pad.
2. Freezer thermistor temperature displays.

### Refrigerator Thermistor Temperature

1. Choose Refrigerator Thermistor temperature display by pressing Ref Temp pad.
2. Refrigerator thermistor temperature displays.

## Mode B Functions

### Automatic Keyboard Functions

Activate and deactivate keyboard by toggling Display Off pad. If high temperature indicator glows, keyboard will disable after 10 minutes. If high temperature indicator is off, keyboard is always enabled. **DO NOT LEAVE KEYBOARD IN ENABLED MODE AFTER PROGRAMMING IS COMPLETE**

### Door Alarm Delay

1. Press Alarm Off pad. Door open indicator will glow. One temperature indicator should glow indicating present delay setting in minutes (indicator 1 means 1 minute, 2 means 2 minutes, etc.) Default delay is 3 minutes.
2. Press Higher Temp pad to decrease delay by 1 minute.
3. Press Lower Temp pad to increase delay by 1 minute.

### Max Ref Run Time Duration

1. Press Max Ref pad. Max Ref light will glow. One temperature indicator should glow indicating present Max Ref run time duration in 2 hour increments (indicator 1 means 2 hours, 2 means 4 hours, etc.) Default delay is 10 hours.
2. Press Higher Temp pad to decrease Max Ref duration by 2 hours.
3. Press Lower Temp pad to increase Max Ref duration by 2 hours.

### Max Frz Run Time Duration

1. Press Max Frz pad. Max Fra light will glow. One temperature indicator should glow indicating present Max Frz run time duration in 4 hours increments (indicator 1 means 4 hours, 2 means 8 hours, etc.) Default delay is 24 hours.
2. Press Higher Temp pad to decrease Max Frz duration by 4 hours.
3. Press Lower Temp pad to increase Max Frz duration by 4 hours.

## Temperature Offset Calibration

Offset amount adjusts temperatures for refrigerator cut-ins and cut-outs by the amount of offset. The chart below shows the indicator and the amount of offset from the factory default setting.

INDICATOR	OFFSET
1	+8
2	+6
3	+4
4	+2
5	0
6	-2
7	-4
8	-6
Coldest	-8

- **Setting Refrigerator Temperature Offset**  
Press Ref Temp pad. Refrigerator indicator and one indicator will glow. Press Higher Temp pad to move offset to the next warmer setting. Press Lower Temp pad to move offset to the next colder setting. Factory default refrigerator offset is -4.

- **Setting Freezer Temperature Offset**

Press Freezer Temp pad. Freezer temperature indicator and one indicator will glow. Press Higher Temp pad to move offset to the next warmer setting. Press Lower Temp pad to move offset to the next colder setting. Factory default freezer offset is 0.

## Defrost Mode Selection

Toggle Hidden Button pad to select adaptive or conventional defrost mode. Hidden Button indicator glows when adaptive defrost has been selected. If Hidden Button indicator is off, conventional defrost is selected. Conventional defrost uses 8 hour CRTD value.

## Forced Defrost

Defrost can be forced to start by pressing and holding the Alarm Off pad for 3 seconds. Program changes will be saved permanently in EEPROM and program mode will exit to Run Mode.

## Forced Pull Down

Compressor start can be forced by pressing and holding Max Frz pad for 3 seconds. Program changes will be saved permanently in EEPROM. Compressor, evaporator fan and condenser fan will come on.

**Exiting Program Mode**

Press Display On pad for 3 seconds to exit Program Mode. Tone will sound three times. Changes made in Program Mode will be permanently saved in EEPROM.

**Note:** If no pad is pressed for 10 minutes, Program Mode will be automatically exited. However, no changes will be saved if Program Mode exits automatically.

**Electronic Testing****Electronic Testing Mode****Forced Defrost Start**

1. Press Display On pad to activate control panel.
2. Simultaneously press and hold Max Ref and Display Off pads for 3 seconds.

**Forced Compressor Start**

1. Press Display On pad to activate control panel.
2. Simultaneously press and hold Max Frz pad and Display Off pad for 3 seconds.

**Open Thermistor Detect**

Alarm sounds and freezer or refrigerator indicator light shows and temperature indicators 4 through 7 will turn on in sequence if either thermistor circuit opens. Refer to Temperature Control Operation Section and Electronic Testing Section.

1. Press Alarm Off pad to turn off alarm.
2. Alarm will reset for normal operation. If condition has not been corrected, alarm will sound again.

## Electronic Functional Description

**WARNING: TO AVOID ELECTRICAL SHOCK WHICH CAN CAUSE SEVERE INJURY OF DEATH, DISCONNECT POWER TO REFRIGERATOR USING POWER SWIDTCH BEFORE SERVICING. WIRES REMOVED DURING DISASSEMBLY MUST BE REPLACED ON PROPER TERMINALS TO INSURE EARTHING AND POLARIZATION. AFTER SERVICING, RECONNECT POWER USING POWER SWITCH.**

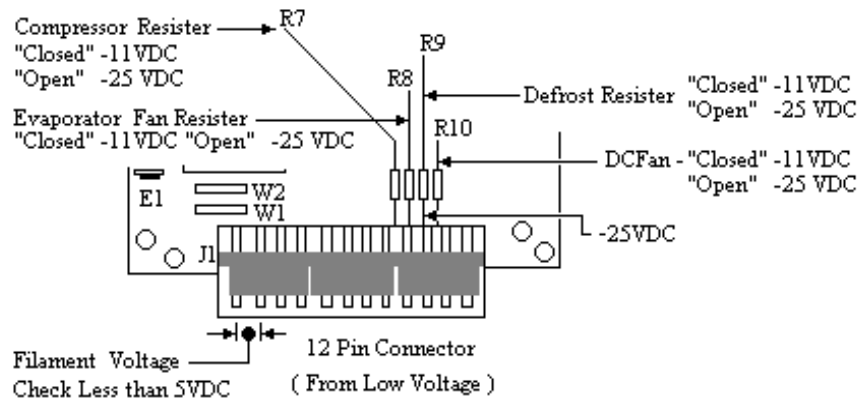
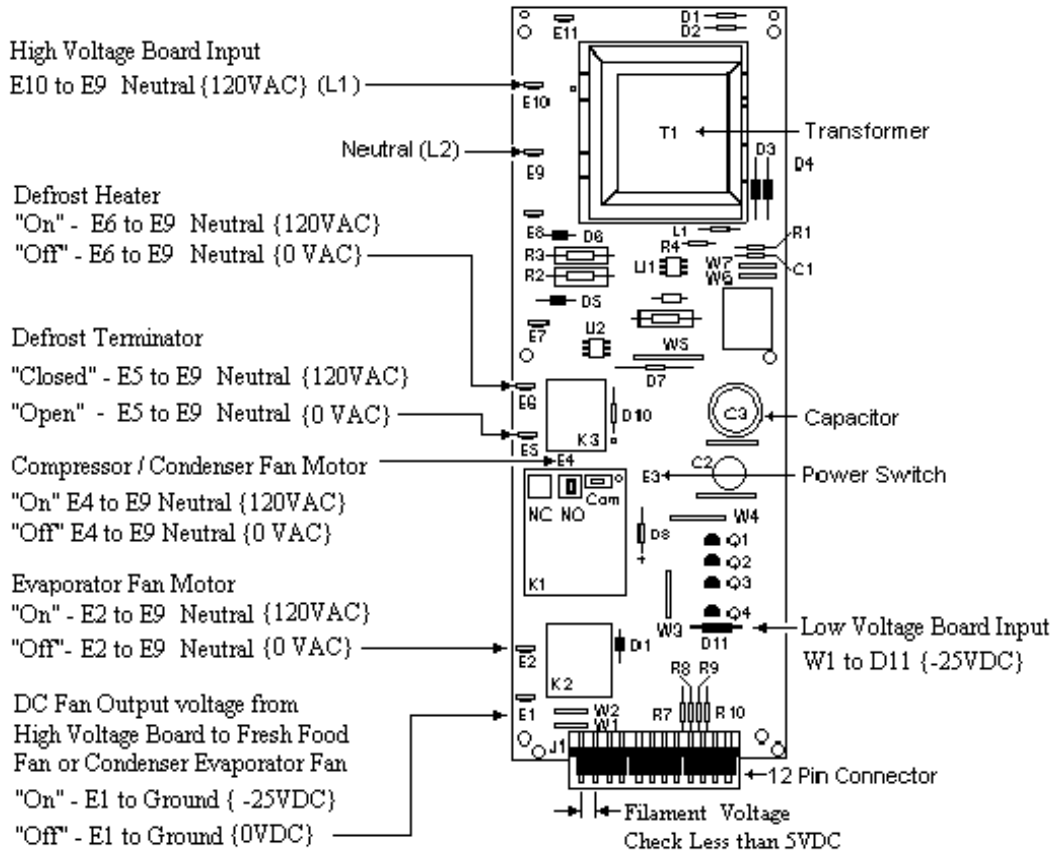

**WARNING**

**DANGER**  
High Voltage

TO AVOID ELECTRICAL SHOCK WHICH CAN CAUSE SEVERE PERSONAL INJURY OR DEATH, DISCONNECT POWER TO REFRIGERATOR USING POWER SWITCH BEFORE SERVICING. WIRES REMOVED DURING DISASSEMBLY MUST BE REPLACED ON PROPER TERMINALS TO INSURE CORRECT EARTHING AND POLARIZATION. AFTER SERVICING, RECONNECT POWER USING POWER SWITCH.

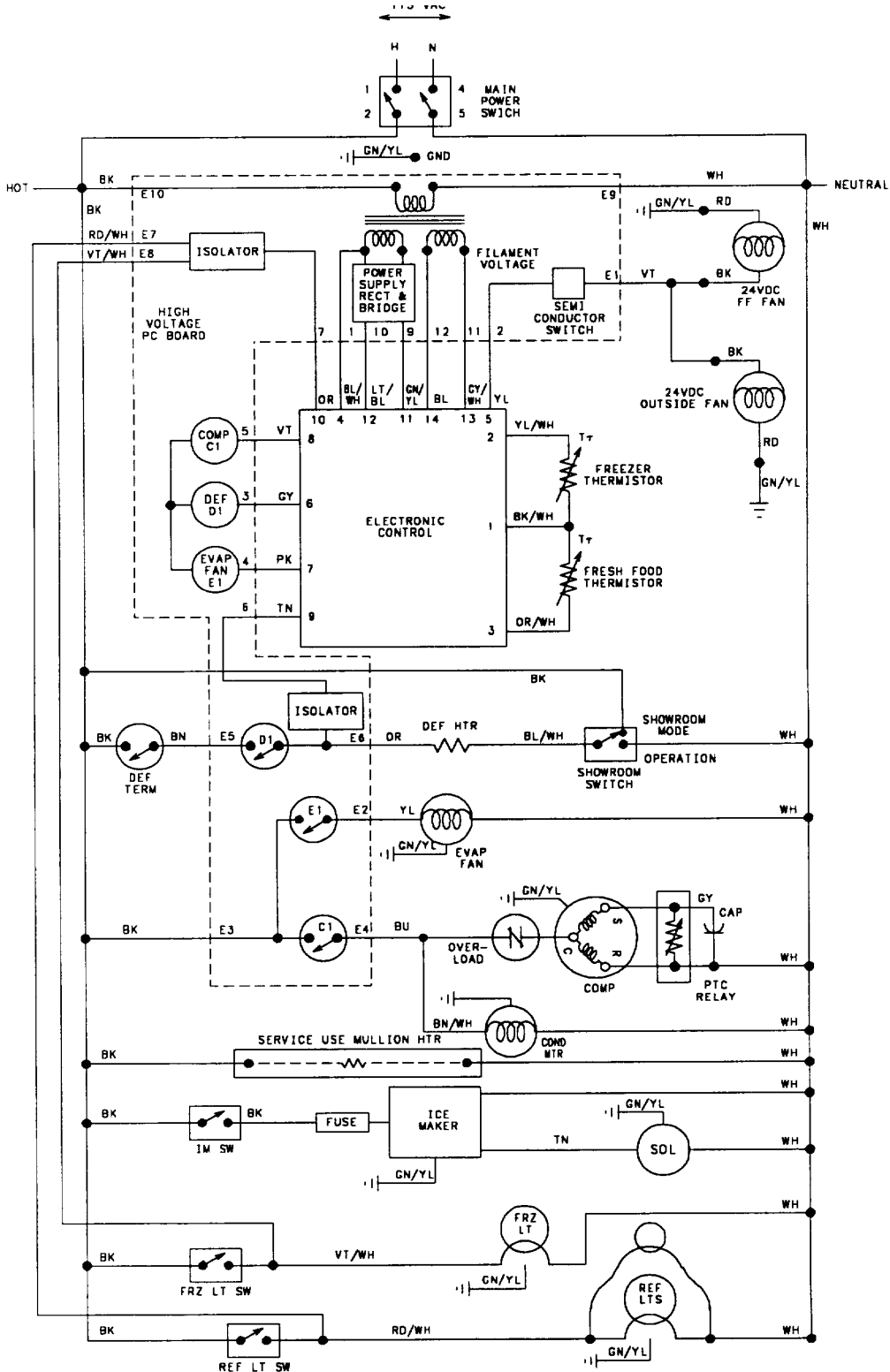



## Electronic Function Description



TO AVOID ELECTRICAL SHOCK WHICH CAN CAUSE SEVERE PERSONAL INJURY OR DEATH, DISCONNECT POWER TO REFRIGERATOR USING POWER SWITCH BEFORE SERVICING. WIRES REMOVED DURING DISASSEMBLY MUST BE REPLACED ON PROPER TERMINALS TO INSURE CORRECT EARTHING AND POLARIZATION. AFTER SERVICING, RECONNECT POWER USING POWER SWITCH.

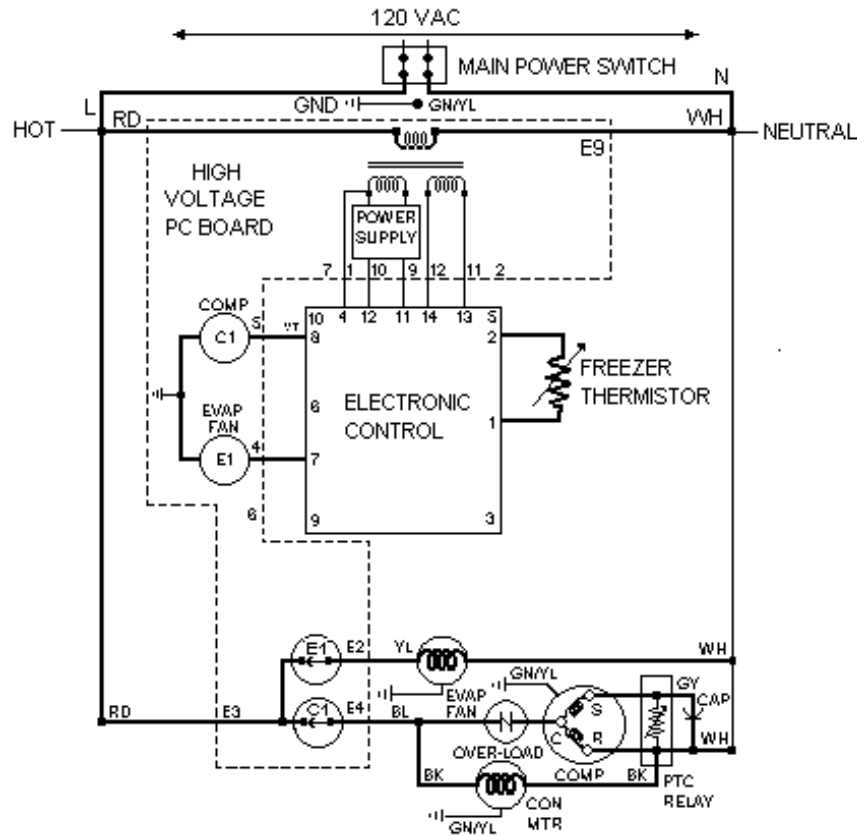

### Freezer Compartment Theory of Operation

As a freezer thermistor warms, the resistance decreases allowing low voltage signal to be sent to electronic control. Electronic control sends two low voltage signals, one to the compressor relay coil (C1) and one to the evaporator relay coil (E1).

As thermistor cools during refrigeration cycle, resistance through thermistor increases blocking low voltage signal to electronic control interrupting circuit.

When both relay coils are energized and both relay contacts are closed, high voltage circuits to evaporator fan motor and compressor / condenser fan motors are complete.

## Electronic Function Description

**⚠ WARNING**

**⚠ DANGER**  
High Voltage

TO AVOID ELECTRICAL SHOCK WHICH CAN CAUSE SEVERE PERSONAL INJURY OR DEATH, DISCONNECT POWER TO REFRIGERATOR USING POWER SWITCH BEFORE SERVICING. WIRES REMOVED DURING DISASSEMBLY MUST BE REPLACED ON PROPER TERMINALS TO INSURE CORRECT EARTHING AND POLARIZATION. AFTER SERVICING, RECONNECT POWER USING POWER SWITCH.

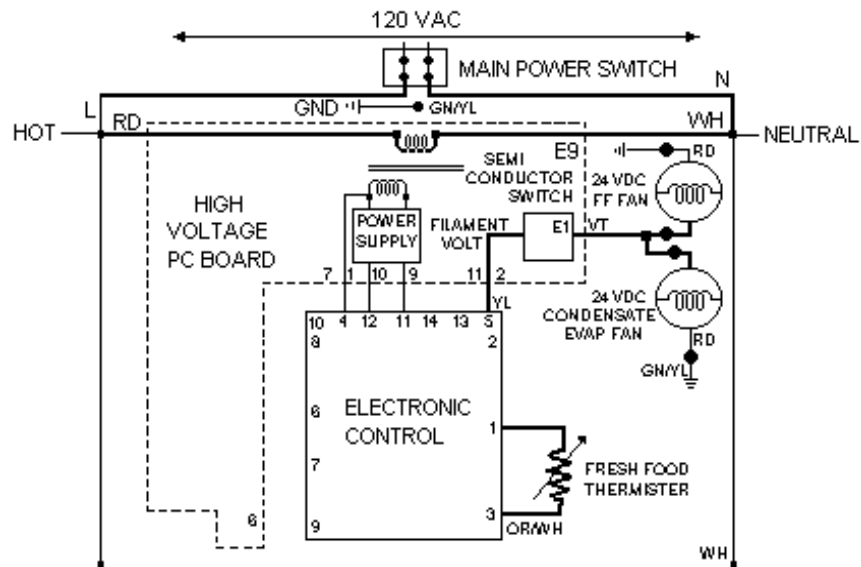

### Refrigeration Compartment Theory of Operation

As fresh food thermistor warms, resistance decreases allowing low voltage signal to be sent to the electronic control. Electronic control sends a low voltage signal to semiconductor switch for DC fresh food fan and DC condensate evaporator fan.

As fresh food thermistor cools, resistance increases blocking low voltage signal to electronic control interrupting circuit to DC fresh food fan and DC condensate evaporation fan.

Both fans begin operating. Fresh food fan circulates freezer air into fresh food compartment. Condensate evaporator fan circulates air over condensate drain pan aiding in evaporation.

## Electronic Function Description

**WARNING**

**DANGER**  
High Voltage

TO AVOID ELECTRICAL SHOCK WHICH CAN CAUSE SEVERE PERSONAL INJURY OR DEATH, DISCONNECT POWER TO REFRIGERATOR USING POWER SWITCH BEFORE SERVICING. WIRES REMOVED DURING DISASSEMBLY MUST BE REPLACED ON PROPER TERMINALS TO INSURE CORRECT EARTHING AND POLARIZATION. AFTER SERVICING, RECONNECT POWER USING POWER SWITCH.

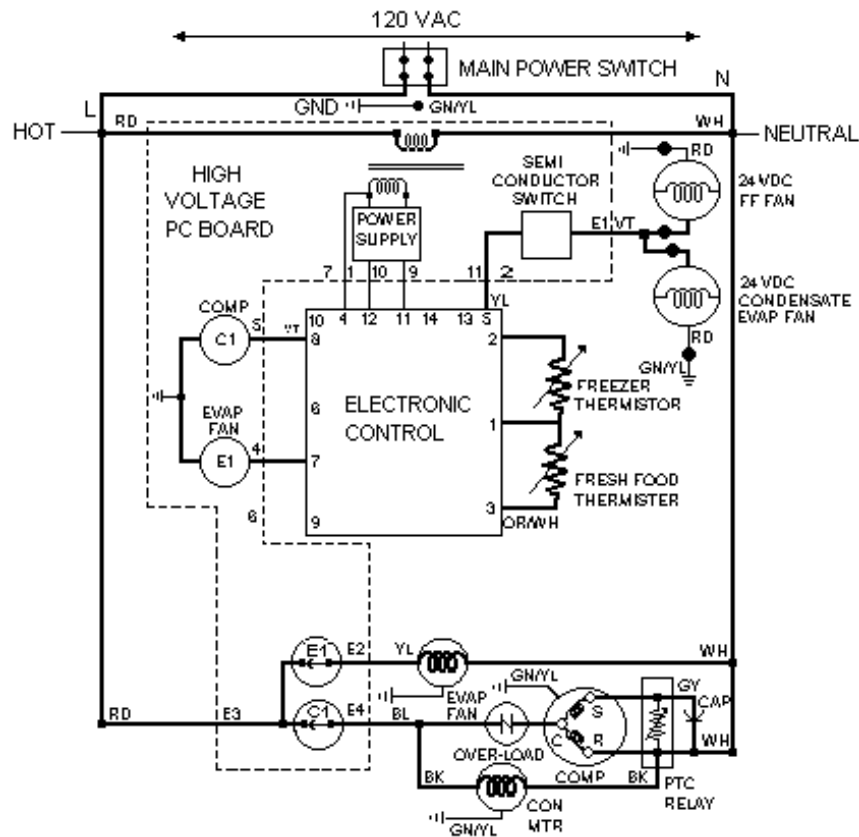

## Refrigerator and Freezer Compartment theory of Operation

If both freezer and fresh food thermistors are warm, their resistance drops (see table Refrigerator and Freezer Thermistor in Temperature Control Section) and the electronic signals for compressor / condenser fan motor operation and for operation of fresh food and condensate evaporator fans.

After freezer thermistor cools sufficiently to raise resistance and block the signal to the electronic control, compressor / condenser fan motor will shut off.

However, fresh food and condensate evaporator fans will continue to run until fresh food thermistor cools and signal is blocked to electronic control.

If fresh food thermistor cools before freezer thermistor, electronic control will interrupt circuit to fresh food and condensate evaporator fans while evaporator fan motor will continue to operate under control of freezer thermistor.

## Electronic Function Description



TO AVOID ELECTRICAL SHOCK WHICH CAN CAUSE SEVERE PERSONAL INJURY OR DEATH, DISCONNECT POWER TO REFRIGERATOR USING POWER SWITCH BEFORE SERVICING. WIRES REMOVED DURING DISASSEMBLY MUST BE REPLACED ON PROPER TERMINALS TO INSURE CORRECT EARTHING AND POLARIZATION. AFTER SERVICING, RECONNECT POWER USING POWER SWITCH.

**IMPORTANT:** When the showroom switch is OFF, the isolator sees line voltage which keeps the electronic controller from signaling the evaporator fan motor or compressor relay coils and keeps the fresh food and condensate evaporator fans off.

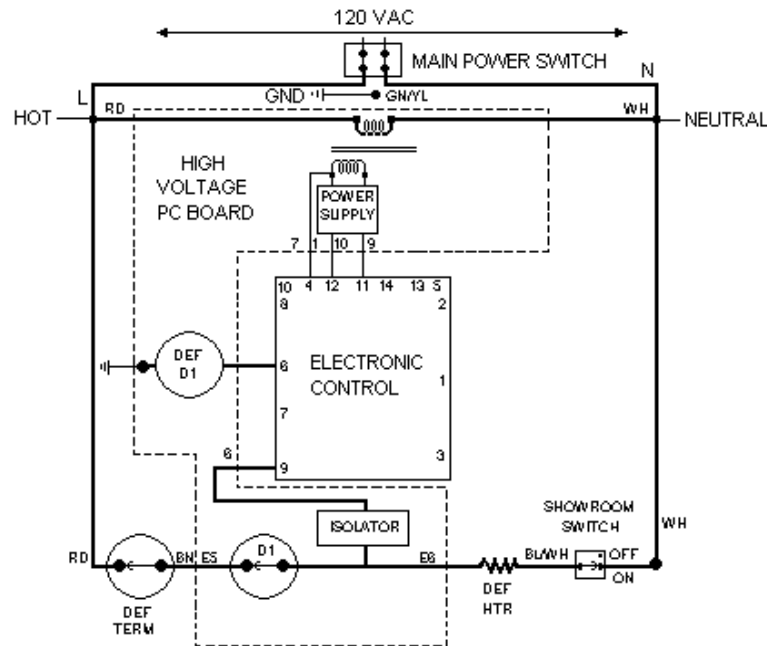

## Adaptive Defrost Theory of Operation

After designated compressor run time, refrigeration cycle is interrupted and electronic control sends a low voltage signal to defrost relay coil (def D1).

Powering the relay coil closes contact (D1) completing high voltage circuit to defrost heater through closed defrost terminator (closes at 15°F).

Isolator, which is part of high voltage PC board, recognizes presence of line voltage to defrost heater and sends low voltage signal to electronic control.

Electronic control keeps count of number of minutes defrost terminator remains closed (opens at 48°F).

Length of time defrost terminator is closed determines if the next defrost cycle advances by 4 hours of compressor run, stays at the same interval, or delays by 4 hours of compressor run.

If defrost terminator does not open before 29 minutes, defrost cycle is automatically terminated by electronic control and refrigeration cycles will resume after 6 minutes dwell time.

**WARNING**

**▲ DANGER**  
High Voltage

TO AVOID ELECTRICAL SHOCK WHICH CAN CAUSE SEVERE PERSONAL INJURY OR DEATH, DISCONNECT POWER TO REFRIGERATOR USING POWER SWITCH BEFORE SERVICING. WIRES REMOVED DURING DISASSEMBLY MUST BE REPLACED ON PROPER TERMINALS TO INSURE CORRECT EARTHING AND POLARIZATION. AFTER SERVICING, RECONNECT POWER USING POWER SWITCH.

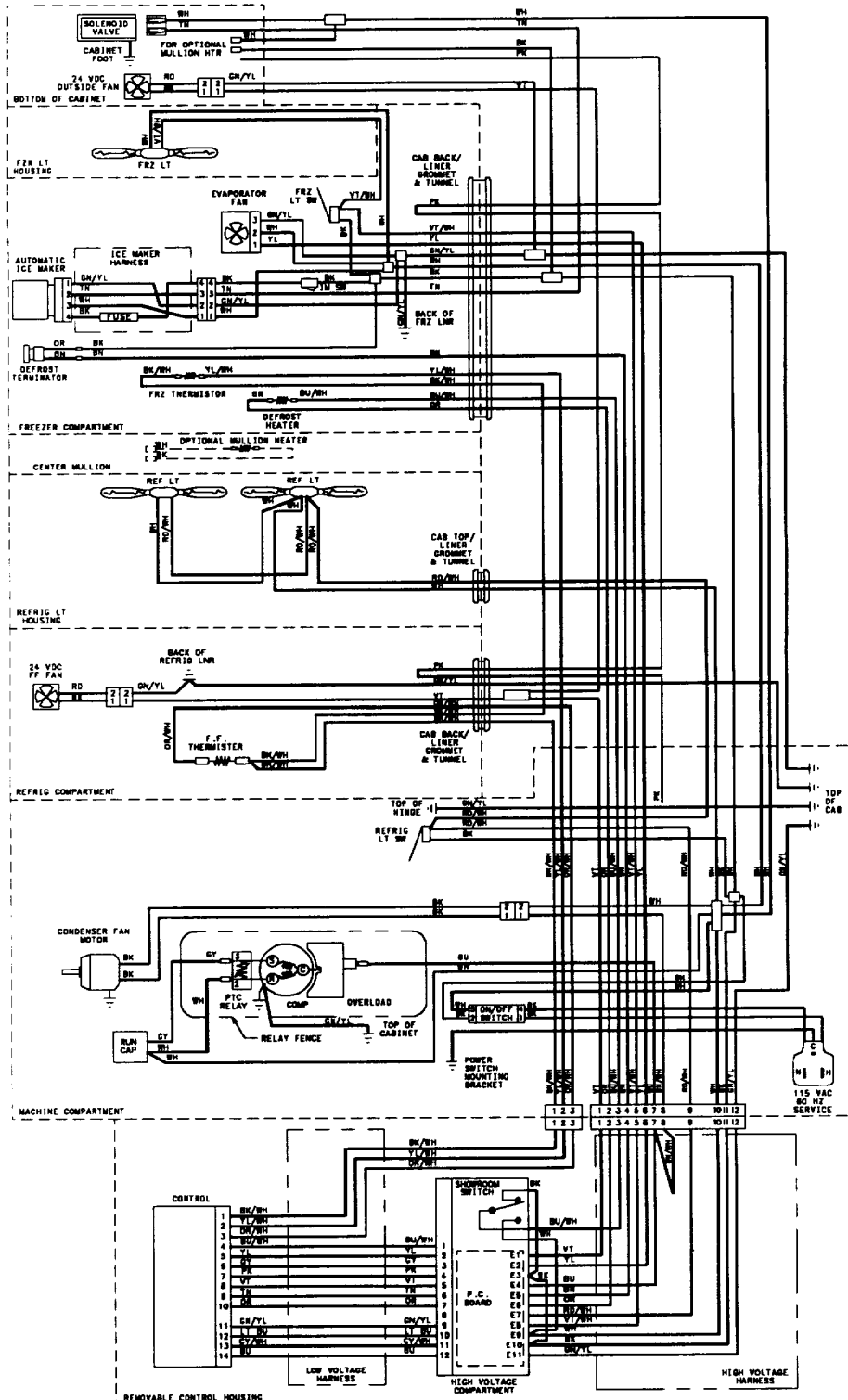

Filename: VCSB48021.doc  
Directory: D:\VBCODE\IPLUTILS\PDFGenerator\InputData\F90575 TechVCSB481-482  
Template: C:\Documents and Settings\tomw.EYECOM\Application  
Data\Microsoft\Templates\Normal.dot  
Title:  
Subject:  
Author: Viking Range  
Keywords:  
Comments:  
Creation Date: 3/21/2002 2:27 PM  
Change Number: 3  
Last Saved On: 3/28/2003 4:36 PM  
Last Saved By: Ken Sievert  
Total Editing Time: 1 Minute  
Last Printed On: 3/28/2003 7:21 PM  
As of Last Complete Printing  
Number of Pages: 1  
Number of Words: 0 (approx.)  
Number of Characters: 2 (approx.)