



Preferred Service

Service Manual

This manual is to be used by qualified appliance technicians only. Viking does not assume any responsibility for property damage or personal injury for improper service procedures done by an unqualified person.

Freestanding French Door Bottom-Mount Refrigerator

This Base Manual covers general and specific information including, but not limited to the following models:

RDDFF236



Description	Page
IMPORTANT INFORMATION	
Safety Information	3
Warnings	4
Model – Serial Number Matrix.....	5
OPERATION	
Entering Programming Mode.....	11
DIAGNOSTICS	
Defrost Operation	14
Entering Forced Defrost Mode	14
Entering Service Test Mode.....	16
Service Tests	17
101 Defrost Heater and Defrost Circuit	17
102 Compressor/Condenser Fan	17
112 Freezer Fan	17
121 Damper Operation	18
131 Mullion Heater	18
141 Fresh Food Thermistor	18
142 Freezer Thermistor	18
146 Machine Compartment Thermistor	19
151 Fresh Food Door State	19
152 Freezer Food Door State.....	19
153 Disable Internal Light.....	19
163 Water Dispenser.....	20
174 Water Actuator Internal Dispenser.....	20
182 LED Indicator.....	20
183 Keypad Operation.....	20
191 Ice Maker Water Valve.....	21
201 Mullion Heater Override.....	21
202 Default Defrost Operation.....	21
203 Show Temperature Set Points	21
211 Fresh Food Temperature Offsets	22
212 Freezer Temperature Offsets.....	22
221 Reset Default Settings	22
231 Water Filter Usage.....	23
232 Water Filter Days In Use.....	23
241 Software Revision Main Control Board.....	23
242 Software Revision Display Board	23

SERVICE DIAGNOSTICS AND PROCEDURES

Parts Location–Upper Control Board and Main Control Board	24
Parts Location–Secondary Control Board	25
Component Testing.....	26
Component Testing–Control Board	26
Main Control Board Wiring Connections	27
Secondary Control Board Wiring Connections	28
Parts Location–Refrigerator.....	29

Description	Page
SERVICE DIAGNOSTICS AND PROCEDURES–DISASSEMBLY	
Refrigerator Light Bulb.....	30
Refrigerator Light Housing.....	30
Control Board	31
Refrigerator Temperature Sensor.....	32
Vegetable/Meat Temperature Control.....	32
Refrigerator Light Switch	33
Water Tank.....	33
Water Dispenser.....	34
Refrigerator Damper.....	35
Water Flow	36
Parts Location–Freezer	37
Freezer Drawer Switch.....	38
Freezer Light Bulb	38
Freezer Light Housing	38
Freezer Drawer, Bins, Baskets, Glides and Glide Adapters	39
Ice Maker (shown here with cover off).....	42
Thermal Cut Out (TCO).....	45
Component Testing–Ice maker.....	45
Freezer Thermistor	46
Evaporator Cover	47
Evaporator Fan.....	47
Defrost Heater	48
Defrost Thermostat.....	49
Parts Location–Rear.....	50
Main and Secondary Control Boards.....	51
Overload Relay.....	52
Condenser Fan.....	52
Water Valve	53
Troubleshooting Guide	54
WIRING AND SCHEMATICS	
Full Schematic.....	57
Wiring Diagram.....	58

SAVE THESE INSTRUCTIONS

REVIEW ALL SERVICE INFORMATION IN THE APPROPRIATE SERVICE MANUAL AND TECHNICAL SHEETS BEFORE BEGINNING REPAIRS.



Pride and workmanship go into every product to provide our customers with quality appliances. It is possible, however, that during the lifetime of a product, service may be required. Products should be serviced only by a qualified authorized service technician who is familiar with the safety procedures required to perform the repair and is equipped with the proper tools, parts, testing instruments, and the appropriate service manual.

Safety Information

We have provided many important safety messages throughout this manual and on the appliance. Always read and obey all safety messages. This is a safety alert symbol.



This symbol alerts personnel to hazards that can kill or hurt you and others. All safety messages will be preceded by a safety alert symbol and the word "DANGER", "WARNING" or "CAUTION". These words mean:

 DANGER
Immediate hazards which WILL result in severe personal injury or death.
 WARNING
Hazards or unsafe practices which COULD result in severe personal injury or death.
 CAUTION
Hazards or unsafe practices which COULD result in minor personal injury, product or property damage.

All safety messages will identify the hazard, tell you how to reduce the chance of injury, and inform you what can happen if the instructions are not followed.

 WARNING
To avoid risk of serious injury or death, repairs should not be attempted by unauthorized personnel.

 CAUTION
VIKING will not be responsible for any injury or property damage from improper service procedures. If performing service on your own product, you must assume responsibility for any personal injury or property damage which may result.

To locate an authorized service agent, call:
Viking Customer Service
Phone No. 1-888-845-4641

Address your written correspondence to:
Viking Preferred Service
1803 HWY 82 West
Greenwood, MS 38930

Warnings

Read and follow all instructions before using this appliance to prevent the potential risk of fire, electric shock, personal injury, or damage to the appliance as a result of improper usage of the appliance. Use appliance only for its intended purpose as described in this manual.

To ensure proper and safe operation: appliance must be properly installed and grounded by a qualified technician. DO NOT attempt to adjust, repair, service, or replace any part of your appliance unless it is specifically recommended in this manual. All other servicing should be referred to a qualified servicer.

Make sure that incoming voltage is the same as unit rating. An electric rating plate specifying voltage, frequency, wattage, amperage, and phase is attached to the product.

Electrical Requirements

Assure that the electrical installation is adequate and in conformance with the National Electrical Code, ANSI/NFPA 70-latest edition or Canadian Electrical Code C22.1-1998 and C22.2 No. 0-M91 (or latest edition), and all local codes and ordinances. A 115 volt, 60-Hz, 15 amp, fused, electrical supply is required. It is required that a separate circuit serving only this appliance be provided. This appliance is equipped with a power supply cord having a 3-prong grounding plug. To minimize possible shock hazard, the cord must be plugged into a mating 3-prong, grounding-type wall receptacle. DO NOT use an extension cord.



WARNING

TIP OVER HAZARD

Appliance is top heavy and tips easily when not completely installed. Keep doors closed until appliance is completely installed and secured per installation instructions.

Use two or more people to move and install appliance. Failure to do so can result in death or serious injury.



WARNING

ELECTRICAL SHOCK HAZARD

Disconnect power or turn power disconnect switch to "OFF" position before removing top grille. Failure to do so can result in death or electrical shock.



WARNING

ELECTRICAL SHOCK HAZARD

Plug into a grounded 3-prong outlet. If a 2-prong wall receptacle is encountered, contact a qualified electrician.

DO NOT remove ground prong.

Unit must be grounded at all times.

DO NOT use an adapter.

DO NOT use an extension cord.

Failure to follow these instructions can result in death, fire, or electrical shock.



WARNING

BURN HAZARD

DO NOT touch condenser coils near defrost pan. Doing so can result in burns.

Model – Serial Number Matrix

The serial number and model number for your appliance are located on the identification plate mounted on the upper right side of the door opening.

Model Numbers

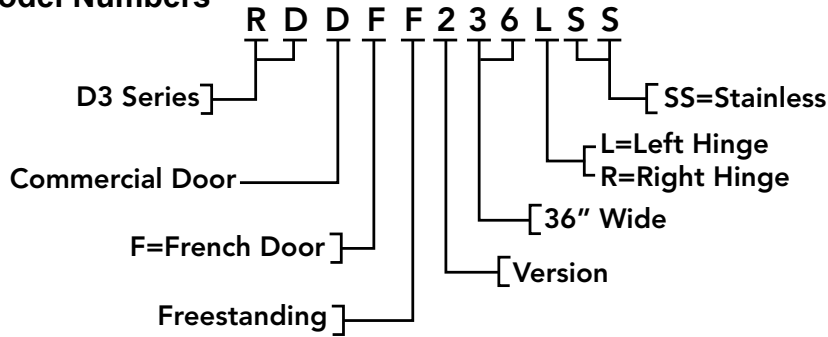

Serial Numbers

K15111363
Serial Number

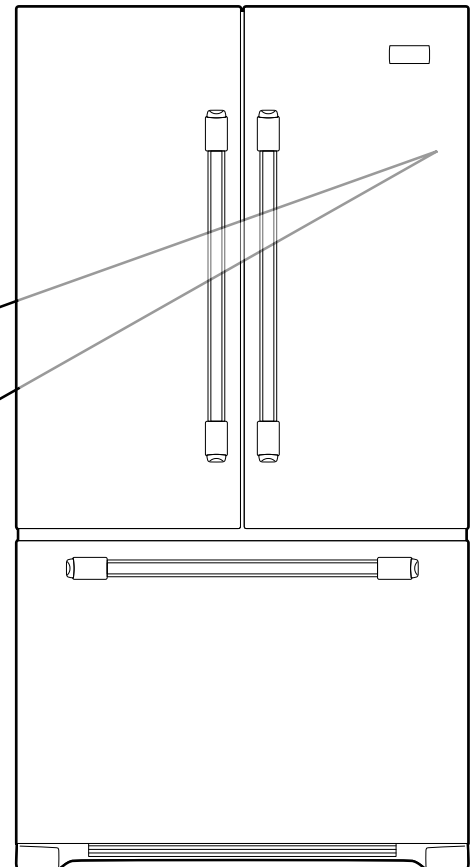
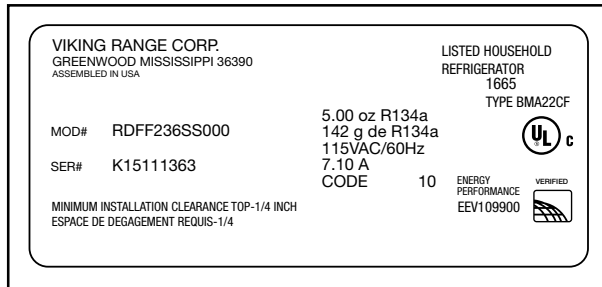

Using the Controls

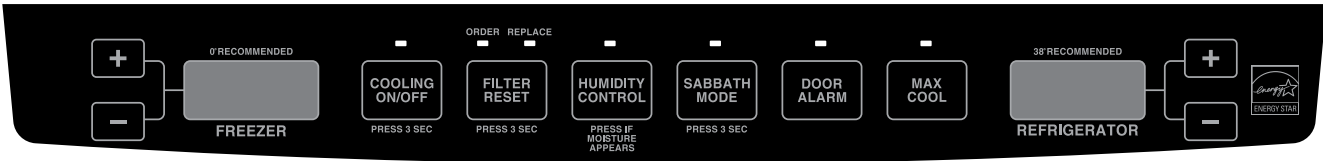

Control panel

Temperature Controls

Initial Temperature Setting

Temperatures are preset at the factory at 38°F (3°C) in the refrigerator compartment and 0°F (-18°C) in the freezer compartment.

Adjusting the Control

24 hours after adding food, you may decide that one or both compartments should be colder or warmer. If so, adjust the control as indicated in the Temperature Control Guide below.

- The control panel is located on the inside of the refrigerator compartment at the top.
- The first touch of the + or – pads shows the current temperature setting.
- The display will show the new setting for approximately three seconds, and then return to the actual temperature currently within that compartment.
- **DO NOT** change either control more than one degree at a time. Allow temperature to stabilize for 24 hours before making a new temperature adjustment.

IMPORTANT: Wait 24 hours for your refrigerator to cool completely before adding food. If you add food before the refrigerator has cooled completely, your food may spoil.

Temperature Control Guide	
Refrigerator too cold	Set the refrigerator control to next higher number by pressing the “+” pad.
Refrigerator too warm	Set the refrigerator control to next lower number by pressing the “-” pad.
Freezer too cold	Set the freezer control to next higher number by pressing the “+” pad.
Freezer too warm	Set the freezer control to next lower number by pressing the “-” pad.
Cooling On/Off	Press and hold Cooling On/Off for 3 seconds. The LED will light up to indicate that cooling is off. Press and hold button again to turn on the cooling. The LED will turn off.

- The recommended settings should be correct for normal household refrigerator use. The controls are set correctly when milk or juice is as cold as you like and when ice cream is firm.
- If the temperature is too warm or too cold in the refrigerator or freezer, first check the air vents to be sure they are not blocked before adjusting the controls.

Adjusting Controls (cont.)

If you need to adjust the temperature in either the refrigerator or freezer compartment, use the settings listed in the chart as a guide.

To Adjust Set Point Temperatures:

The first touch of the (+) or (-) touch pad displays the current temperature set point.

- Press the (+) or (-) touch pads until the desired temperature set point is displayed.

Note: Except when first turning on the refrigerator, DO NOT adjust either temperature control more than one setting at a time. Wait 24 hours between adjustments for the temperature to stabilize.

Temperature Adjustment Chart

Condition/Reason	Adjustment
Refrigerator too warm	Adjust REFRIGERATOR Control 1° lower
Freezer too warm/too little ice	Adjust FREEZER Control 1° lower
Refrigerator too cold	Adjust REFRIGERATOR Control 1° higher
Freezer too cold	Adjust FREEZER Control 1° higher

Additional Control Center Features

Humidity Control

The Humidity Control feature turns on a heater to help reduce moisture on the door hinge seal. Use in humid environments or when you notice moisture on the door hinge seal. The refrigerator uses more energy when Humidity Control is on.

- Press Humidity Control when the environment is warm and more humid, or if you notice moisture on the door hinge seal. The indicator light will be lit when humidity control is ON.
- Press Humidity Control again to turn OFF and save energy when the environment is less humid.



Sabbath Mode

The Sabbath Mode is designed for those whose religious observances require turning off the lights and dispensers.

ON - All interior lights and alarm tones will be disabled.

OFF - All interior lights and alarm tones will be enabled.

- Press and hold the Sabbath Mode touch pad for 3 seconds or until the indicator light is lit to turn on this feature. Press and hold the Sabbath Mode touch pad again to turn off this feature.



Door Alarm

The Door Alarm feature sounds a chime every few seconds when the refrigerator door has been left open for 5 continuous minutes. The chime will sound until the door is closed or Door Alarm is turned off.

- Press the Door Alarm to turn this feature ON or OFF. The indicator light will be lit when the Door Alarm feature is on.



Max Cool

The Max Cool feature assists with periods of high refrigerator use, full grocery loads, or temporarily warm room temperatures.

- Press Max Cool to set the freezer and refrigerator to the lowest temperature settings. Press Max Cool again to return to the normal refrigerator set point.

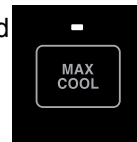

Note: The Max Cool feature will automatically shut off in approximately 12 hours.

Filter Reset

The Filter Reset control allows you to restart the water filter status tracking feature each time you replace your water filter. See “Water Filtration System.”

- Press and hold the Filter Reset touch pad for 3 seconds, until the Order or Replace light turns off.

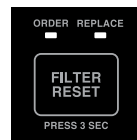

User Preferences

The control center allows you to set user preferences, if desired.

Temperature Display (F_C)

This preference allows you to change the temperature display.

F - Temperature in degrees Fahrenheit

C - Temperature in degrees Celsius

Alarm (AL)

This preference allows you to turn off the sound of all alarms.

ON - You will hear the alarm sound.

OFF - You will not hear the alarm sound.

To Access the User Preferences Menu:

1. Press and hold the Door Alarm touch pad for 3 seconds. The preference name will appear in the Freezer display and the preference status (F or C) or (ON or OFF) will appear in the Refrigerator display.
2. Use the Freezer (+) or (-) touch pads to scroll through the preference names. When the desired preference name is displayed, press the Refrigerator (+) or (-) touch pads to change the preference status.
3. Set your preferences by pressing and holding the Door Alarm touch pad for 3 seconds,

Adjustable Humidity Zone™

You can control the amount of humidity in the Adjustable Humidity Zone drawer. Adjust the control to any setting between **LOW** and **HIGH**. **LOW** (open) for best storage of fruits and vegetables with skins. **HIGH** (closed) for best storage of fresh, leafy vegetables.

Adjustable Cold Zone™

The Adjustable Cold Zone drawer is a full-width drawer with adjustable temperature control. This drawer can be used for large party trays, deli items, beverages or miscellaneous items.

Adjustable Cold Zone Control

The control, located on the right of the drawer, regulates the air temperature inside the drawer. Set control to “**COLD**” to provide normal refrigerator temperature. Use the **COLDEST** setting for meats or other deli items.

- Cold air directed to the drawer can decrease refrigerator temperature. Refrigerator control may need to be adjusted.
- **DO NOT** place leafy vegetables in the drawer. Colder temperatures could damage leafy produce.

To Remove:

- Lift lid. Pull drawer out to full extension. Tilt the drawer front up and pull straight out.

To Install:

- Push metal glide rails to the back of the refrigerator. Place drawer onto rails and slide drawer back until it falls into place.

Ice Maker and Ice Storage Bin

Alarm Sound

The ice maker and storage bin are located in the freezer compartment.

Turning the Ice Maker On/Off

The On/Off switch is located on the ice maker.

To turn ON the ice maker, press the switch to the “ON” position.

To manually turn OFF the ice maker, press the switch to the “OFF” position.

Note: Your ice maker has an automatic shutoff. The ice maker sensors will automatically stop ice production, but the control will remain in the ON position.

Ice Maker and Ice Storage Bin (cont.)

Ice Production Rate

- Allow 24 hours to produce the first batch of ice. Discard the first three batches of ice produced.
- The ice maker should produce approximately 8 to 12 batches of ice in a 24 hour period.
- To increase ice production, lower the freezer and refrigerator temperature. See "Using the Controls." Wait 24 hours between adjustments.

Remember

- The quality of your ice will be only as good as the quality of the water supplied to the ice maker. **AVOID** connecting the ice maker to a softened water supply. Water softener chemicals (such as salt) can damage parts of the ice maker and lead to poor quality ice. If a softened water supply cannot be avoided, make sure the water softener is operating properly and is well maintained.
- **DO NOT** use anything sharp to break up the ice in the bin. This can cause damage to the ice bin and dispenser mechanism.
- **DO NOT** store anything on top of the ice maker or in the ice storage bin.

Water Filtration System

The water filter is located in the upper right-hand corner of the refrigerator compartment.

Note: DO NOT use with water that is microbiologically unsafe or of unknown quality without adequate disinfection before or after the system. Systems certified for cyst reduction may be used on disinfected waters that may contain filterable cysts.

Replacing the Water Filter

Replacement water filters are available through your local Viking Range Dealer. You may also order filters by calling 1-888-845-4641 or online at vikingrange.com

IMPORTANT: Air trapped in the water system may cause water and filter to eject. Always dispense water for at least 2 minutes before removing the filter or blue bypass cap.

1. Turn filter counterclockwise to remove.
2. Remove sealing label from replacement filter and insert the filter end into the filter head.
3. Turn the filter clockwise until it stops. Snap the filter cover closed.

Note: The dispenser feature may be used without a water filter installed. Your water will not be filtered. If this option is chosen, replace the filter with the blue bypass cap.

Refrigerator Water Filter Cartridge Model RWFFR

Specifications:

Service Flow Rate (Maximum)	0.78 GPM
.....	(2.9 L/min)
Rated Service Life	
RWFFR	
(750 gal. Max).....	750 gal./2838 liters
Maximum Operating Temperature	100°F/38°C
Minimum Pressure Requirement.....	35 psi/241 kPa
Minimum Operating Temperature	33°F/1°C
Maximum Operating Pressure.....	120 psi/827 kPa

Cleaning

 **WARNING**

EXPLOSION HAZARD
Use nonflammable cleaner.
Failure to do so can result in death, explosion, or fire.

Both the refrigerator and freezer sections defrost automatically. However, clean both sections about once a month to avoid buildup of odors. Wipe up spills immediately.

IMPORTANT: Because air circulates between both sections, any odors formed in one section will transfer to the other. You must thoroughly clean both sections to eliminate odors. To avoid odor transfer and drying out of food, wrap or cover foods tightly.

Cleaning (cont.)

To Clean Your Refrigerator:

Note: DO NOT use abrasive or harsh cleaners such as window sprays, scouring cleansers, flammable fluids, cleaning waxes, concentrated detergents, bleaches or cleansers containing petroleum products on plastic parts, interior and door liners or gaskets. DO NOT use paper towels, scouring pads, or other harsh cleaning tools.

1. Unplug refrigerator or disconnect power.
2. Hand wash, rinse, and dry removable parts and interior surfaces thoroughly. Use a clean sponge or soft cloth and a mild detergent in warm water.
3. Wash stainless steel and painted metal exteriors with a clean sponge or soft cloth and a mild detergent in warm water.
4. There is no need for routine condenser cleaning in normal home operating environments. If the environment is particularly greasy or dusty, or there is significant pet traffic in the home, the condenser should be cleaned every 2 to 3 months to ensure maximum efficiency.

If you need to clean the condenser:

- Remove the base grille.
 - Use a vacuum cleaner with a soft brush to clean the grille, the open areas behind the grille and the front surface area of the condenser.
 - Replace the base grille when finished.
5. Plug in refrigerator or reconnect power.

Entering Programming Mode

1. Press and hold the “Door Alarm” keypad.

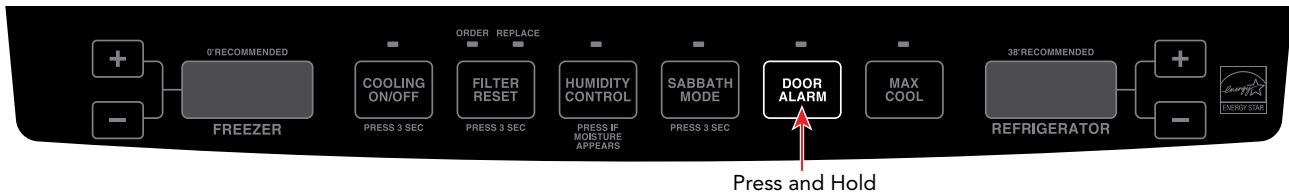

2. Within three seconds, press and hold freezer temperature “-” (down) keypad. Both keypads are now being held in.

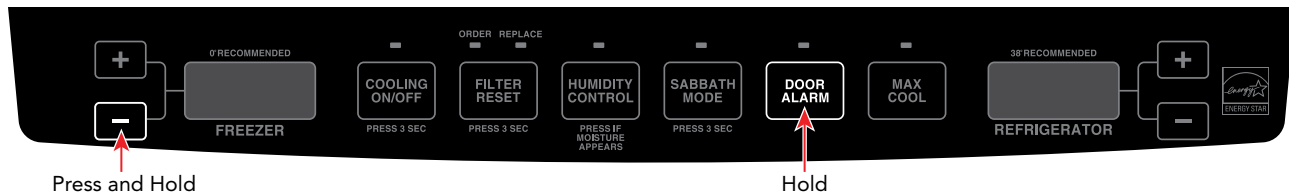

3. While still holding the freezer temperature “-” (down), release the “DOOR ALARM” keypad and wait three seconds.

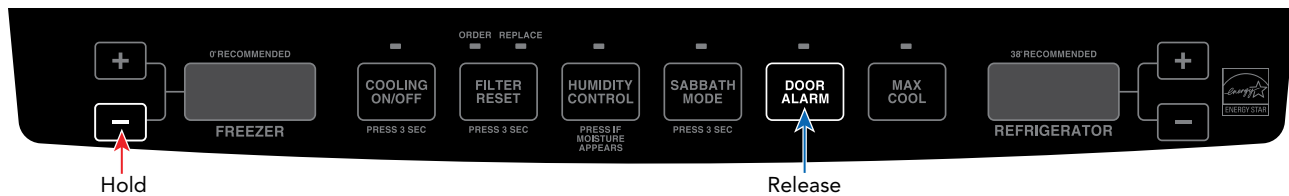

4. When entered successfully, the freezer temperature screen will display PE.



5. Entry is confirmed by pressing the freezer temperature “-” (down) keypad. The refrigerator temperature screen will display a three digit number. These three numbers are the current programming code for this unit. The example below shows code 010.

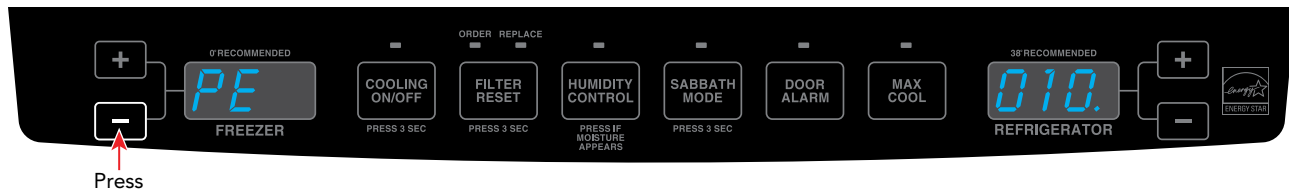

Note: There is a decimal to the right of the last number. This will be explained later.

Entering Programming (continued)

- This code can be verified with the Program CODE printed on the unit serial plate as shown in the example below. The code in the display and the code on the data plate match.

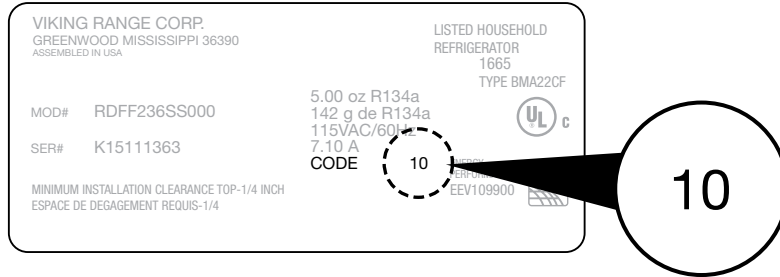

- If the code does **NOT** match, you must enter the proper code into the controller. Below is an example of an improperly programmed controller. The code is showing 022 which does not match the data plate above.

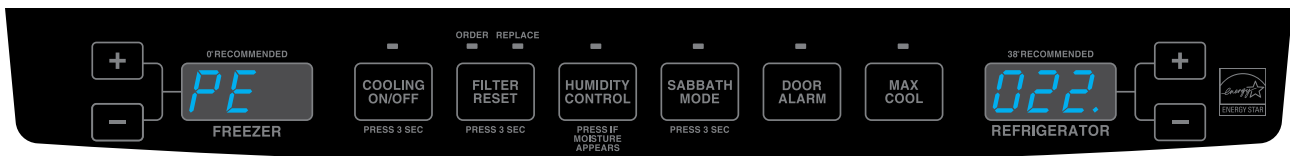

Incorrect code shown above

- As mentioned before, the first digit has a decimal beside it. This indicates that the First digit is in programming mode. Using either the refrigerator temperature “+” (up) or “-” (down) keypads, this digit can be changed from 0-9.

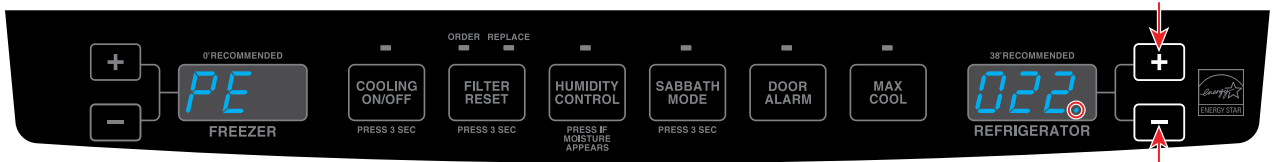

Press either button to scroll through the numbers until the proper number is in the display

- Press the freezer temperature “+” (up) keypad to select the next digit. Using either the refrigerator temperature “+” (UP) or “-” (down) keypads, change the second digit. Repeat this process for the third digit.



Press either button to scroll through the numbers until the proper number is in the display

Entering Programming Mode (continued)

10. Once the desired program code is entered, press and hold the freezer temperature “-” (down) keypad until the program code begins flashing indicating it has been saved.

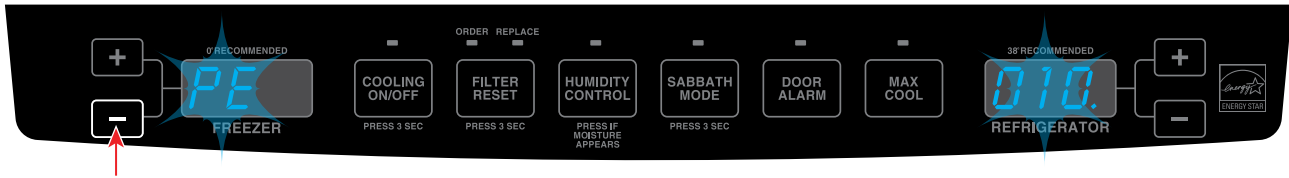

Note: If you attempt to enter an invalid program code, the control will not save the new code, but will beep. (The unit will NOT run with a program code of 0000). Once the program code has been saved, the Programming Mode is exited by pressing any key. If the new code is incorrect, this process should be repeated.

Note: The Programming Mode can be exited at any time by pressing “DOOR ALARM” key for three seconds or will exit if unattended for four minutes.

Defrost Operation

The Control Board adapts the compressor run time between defrosts to achieve optimum defrost intervals by monitoring the length of time the defrost heater is on. After initial power up, defrost interval is 4 hours compressor run time. Defrost occurs immediately after the 4 hours of compressor run time.

Entering Forced Defrost Mode

Enter the Forced Defrost Mode by performing the following:

1. Press and hold the “DOOR ALARM” keypad.

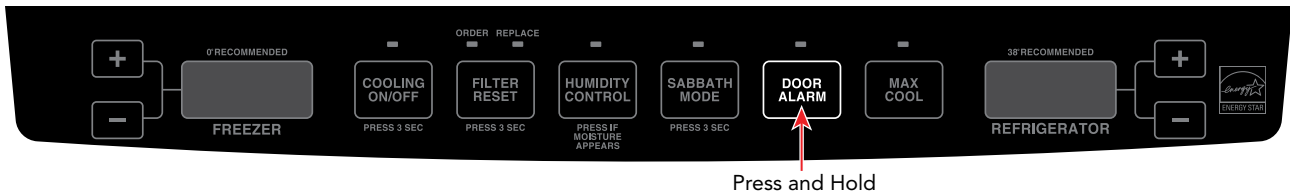

2. Then press and hold refrigerator temperature “-” (down) keypad. Both buttons are now being held in.

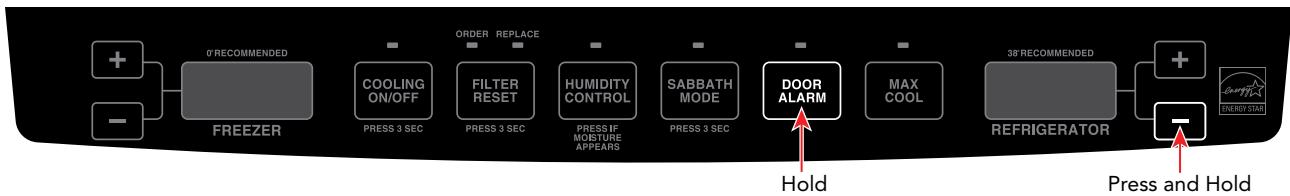

3. While still holding the refrigerator temperature “-” (down) keypad, release the door alarm keypad and wait three seconds.

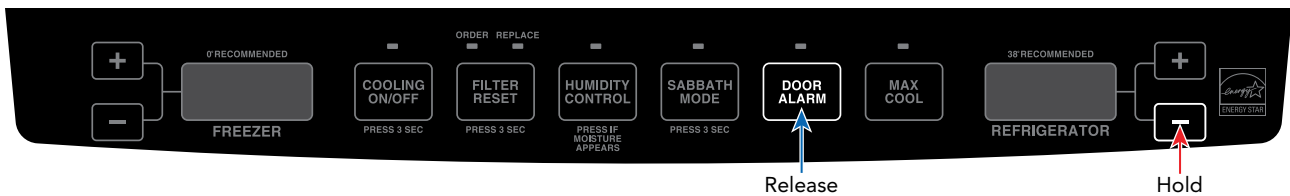

4. When entered successfully, Fd will be displayed in freezer display.



Entering Forced Defrost Mode (continued)

5. Press the refrigerator temperature “-” (down) keypad again. Sh appears in right display.

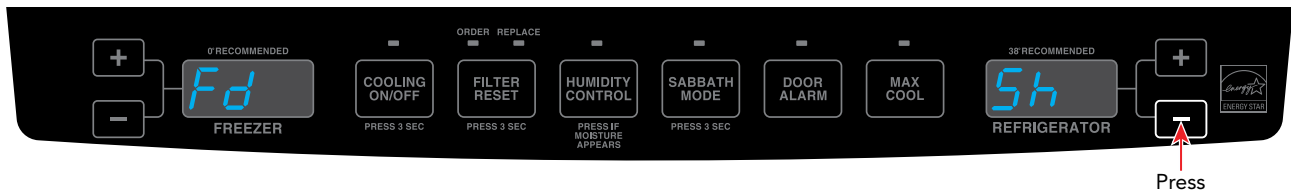

6. Press refrigerator temperature “-” (down) keypad again to force defrost .

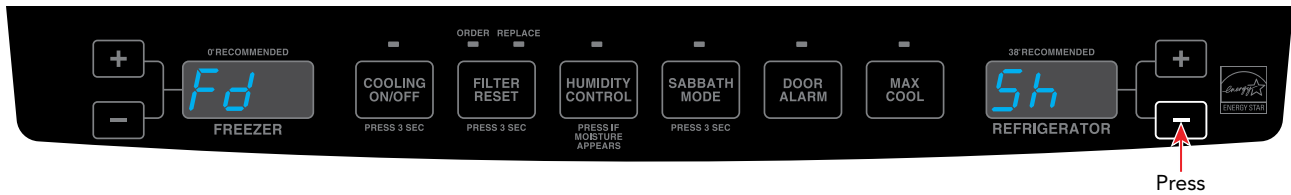

7. Fd and Sh will flash in display indicating unit is in defrost.

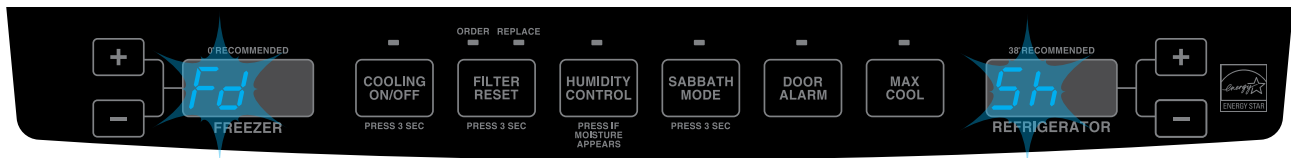

Entering Service Test Mode

1. Press and hold the “DOOR ALARM” keypad.

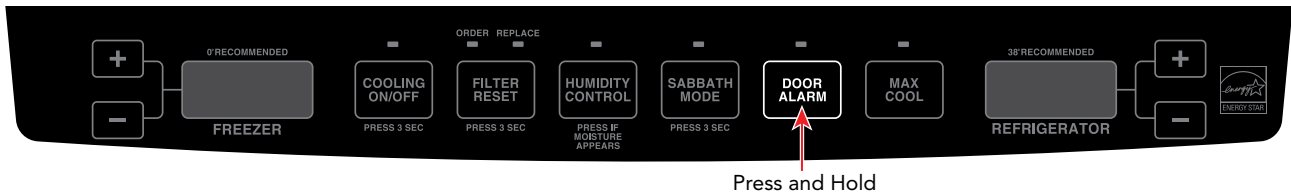

2. Within three seconds, press and hold refrigerator temperature “+” (up) keypad. Both keypads are now being held in.



3. While still holding the refrigerator temperature “+” (up), release the “DOOR ALARM” keypad and wait three seconds.

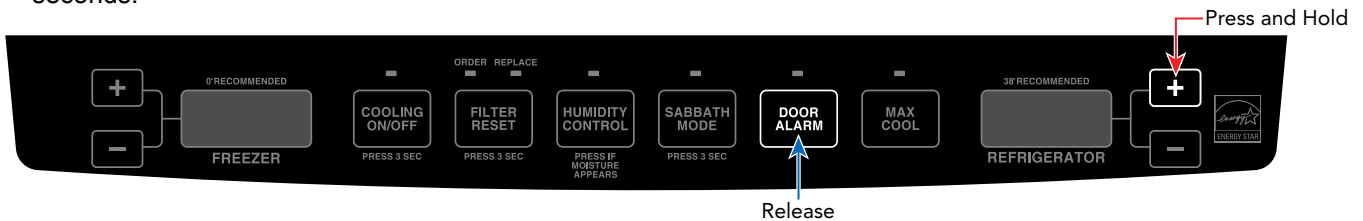

4. When entered successfully, the freezer temperature screen will display SE.



5. Entry is confirmed by pressing the refrigerator temperature “+” (up) keypad. Freezer temperature screen will display 101. Refrigerator screen will display OFF.

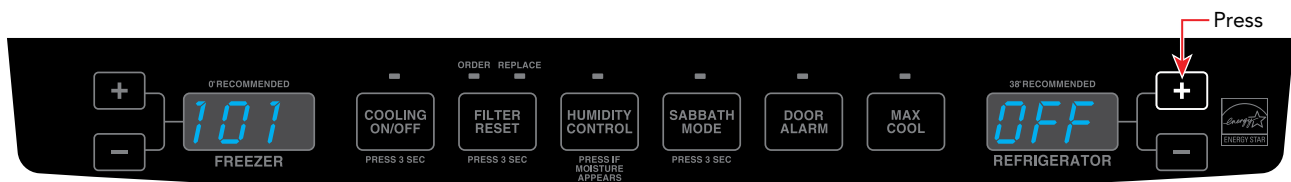

7. To exit Service Test Mode, open and close refrigerator door(s) or hold door alarm for 3 seconds.

Service Tests

When the Test Mode has been entered, the first test will be for the defrost test.

101 Defrost Heater and Defrost Circuit

Press the refrigerator temperature “+” (up) or “-” (down) keypad to energize or de-energize the defrost circuit. The display will read OFF when de-energized as shown below. **OP** when energized with open defrost thermostat and **CL** when energized with closed defrost thermostat.

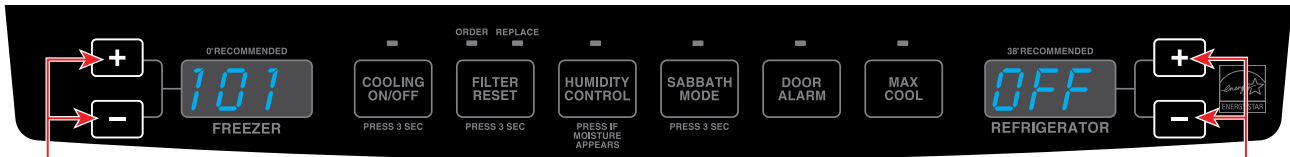

Press either button to toggle through test cycles

Press either button to cycle defrost On and Off

102 Compressor/Condenser Fan

Press the refrigerator temperature “+” (up) or “-” (down) keypad to toggle Compressor/Condenser fan ON and OFF.

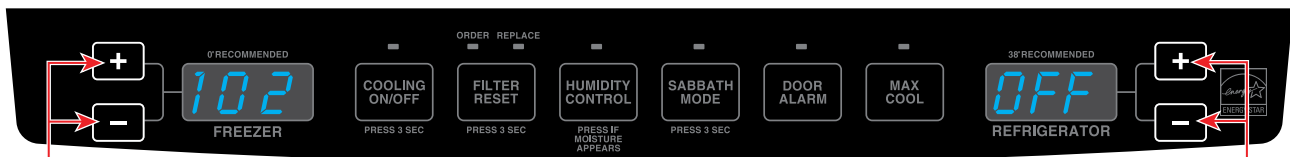

Press either button to toggle through test cycles

Press either button to cycle compressor and condenser fan motor ON and OFF

112 Freezer Fan

Press the refrigerator temperature “+” (up) or “-” (down) keypad to toggle Freezer Fan OFF, High or Low speed.

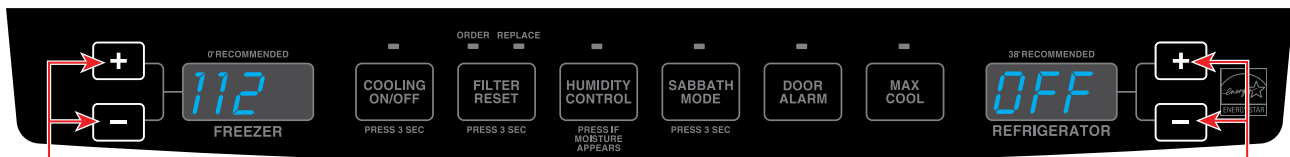

Press either button to toggle through test cycles

Press either button to cycle freezer fan OFF, High or Low speed

Note: Display will show 11.0-14.0 volts for HIGH and 7.75-8.25 volts for LOW. When off 0.0 will be displayed.

Service Tests (continued)

121 Damper Operation

Press the refrigerator temperature “+” (up) or “-” (down) keypad to toggle Damper OP (open) or CL (Closed).

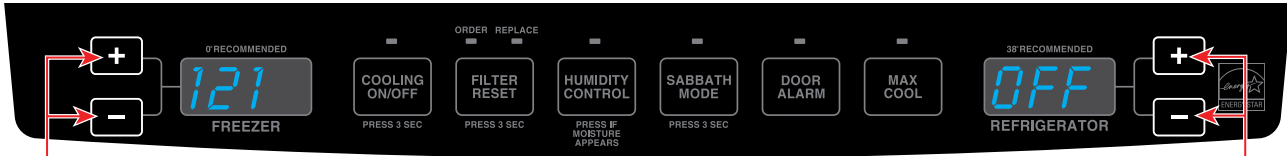

Press either button to toggle through test cycles

Press either button to cycle Damper OPEN or CLOSED

Note: When damper is opening or closing it will display—if damper state is unknown. It can also show DP if damper is moving when initially entering service mode.

131 Mullion Heater

Press the refrigerator temperature “+” (up) or “-” (down) keypad to toggle Mullion Heater Off and On.

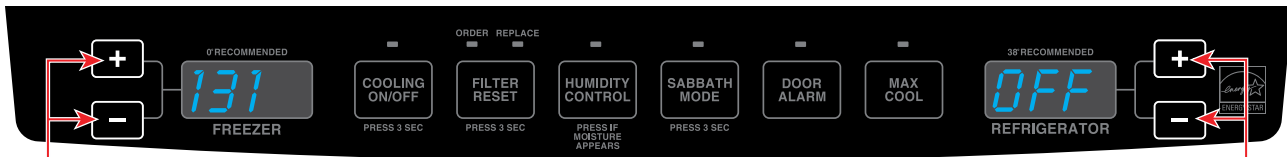

Press either button to toggle through test cycles

Press either button to cycle Mullion Heater ON or OFF

141 Fresh Food Thermistor

This test will check the temperature from the fresh food thermistor. You will see the actual temperature, OP for open thermistor, or SH for shorted thermistor.

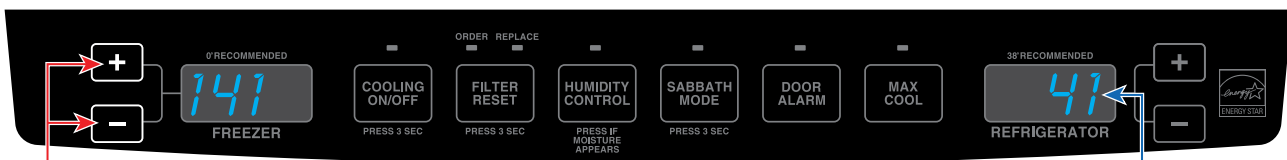

Press either button to toggle through test cycles

Actual temperature in food compartment, OP or SH

142 Freezer Thermistor

This test will check the temperature from the freezer thermistor. You will see the actual temperature, OP for open thermistor, or SH for shorted thermistor.



Press either button to toggle through test cycles

Actual temperature in freezer compartment, OP or SH

Service Tests (continued)

146 Machine Compartment Thermistor

This test will check the machine compartment temperature. You will see the actual temperature, OP open thermistor, or SH shorted thermistor.

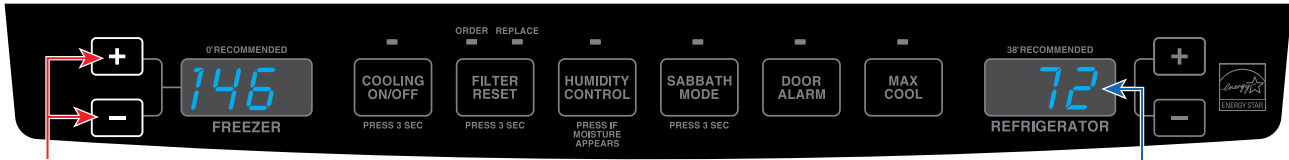

Press either button to toggle through test cycles

Actual temperature in freezer compartment, OP or SH

151 Fresh Food Door State

This test will check the fresh food door switch(es). When either door is open, the display should read OP (open) and when both doors are closed, the display should read CL (closed).

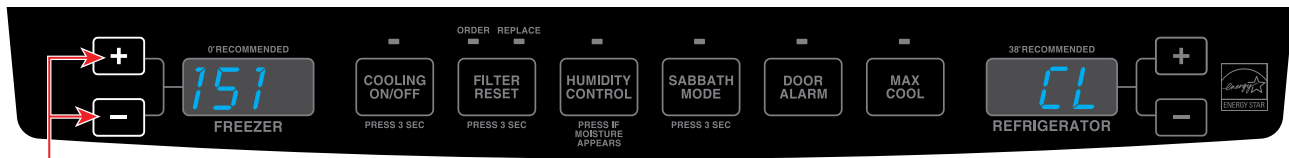

Press either button to toggle through test cycles

Note: By pushing either fresh food door switches, you can toggle state from OP (open) to CL (closed).

152 Freezer Food Door State

This test will check the freezer door switches. When the door is open, the display should read OP (open) and when the door is closed, the display should read CL (closed).

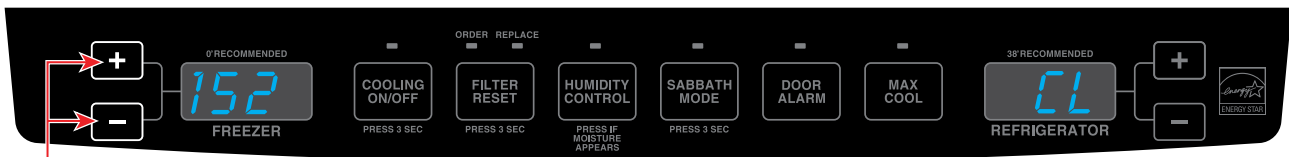

Press either button to toggle through test cycles

Note: By pushing freezer door switch, you can toggle state from OP (open) to CL (closed).

153 Disable Internal Light

This test will enable or disable the internal lights.



Press either button to toggle through test cycles

Press either button to turn internal lights ON or OFF

Service Tests (continued)

163 Water Dispenser

Display shows the state of the water dispenser valve (ON or OFF).

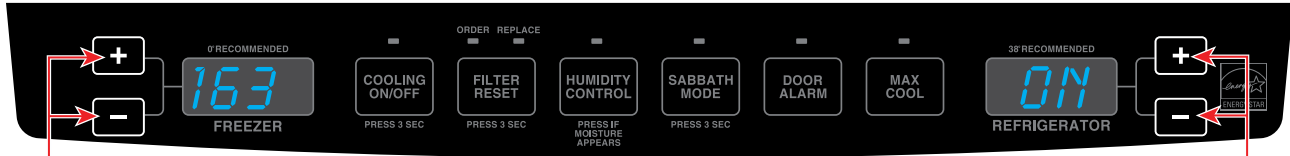

Press either button to toggle through test cycles

Press either button to turn water dispenser valve ON or OFF

174 Water Actuator Internal Dispenser

Display shows the state of the internal dispenser (ON or OFF).



Press either button to toggle through test cycles

Press either button to cycle Internal Dispenser ON or OFF

182 LED Indicator

Press the refrigerator temperature “+” (up) keypad to show operation of LED indicators. All Indicators will flash. Press twice and LED will stop flashing.



Press either button to toggle through test cycles

183 Keypad Operation

Display shows a numeric or letter display indicating the last key pressed.

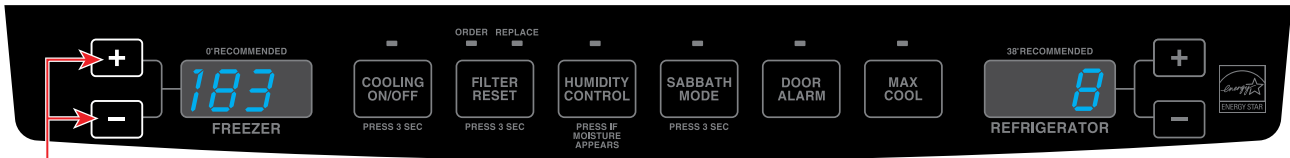

Press either button to toggle through test cycles

Note: Refrigerator + (up) and – (down) keypads have no effect when pressed and freezer temperature keypads remain operational.

Service Tests (continued)

191 Ice Maker Water Valve

Display shows the state of the ice maker water valve (ON or OFF).

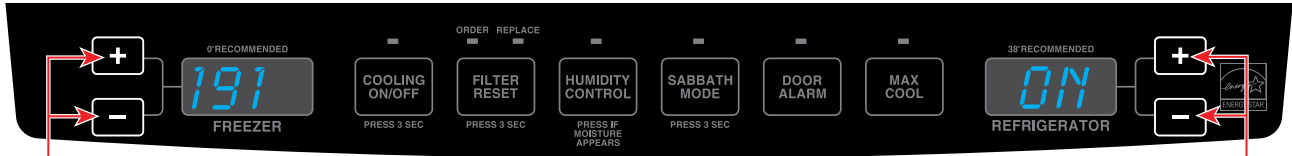

Press either button to toggle through test cycles

Press either button to cycle Ice Maker Valve On or OFF

201 Mullion Heater Override

Press the refrigerator temperature “+” (up) or “-” (down) keypad to cycle this function. When set to OFF, the mullion heater will only operate when the compressor is in the OFF cycle. When set to ON, the heater will operate 100% of the time.

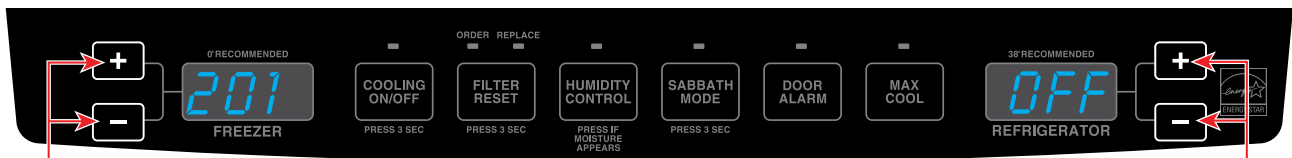

Press either button to toggle through test cycles

Press either button to cycle mullion heater On (100%) or OFF (compressor off)

202 Default Defrost Operation

Press the refrigerator temperature “+” (up) or “-” (down) keypad to toggle defrost operation from normal adaptive defrost (OFF position) to minimum time between defrosts (ON position).

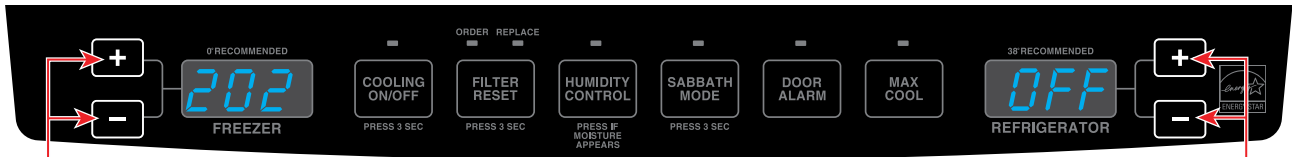

Press either button to toggle through test cycles

Press either button to cycle normal adaptive defrost (OFF) to minimum time between defrosts (ON)

203 Show Temperature Set Points

Press the refrigerator temperature “+” (up) or “-” (down) keypad to change from showing actual temperature (OFF) to show temperature set points only (ON).

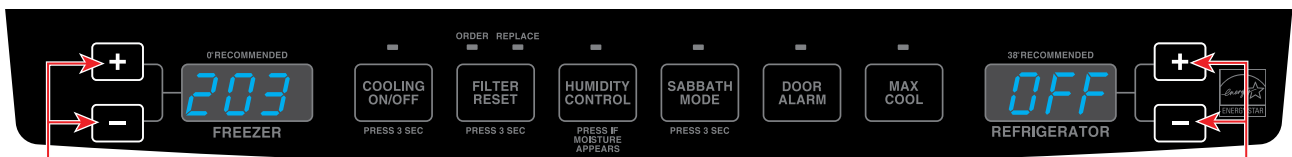

Press either button to toggle through test cycles

Press either button to show actual temperature (OFF) or temperature set points (ON)

Service Tests (continued)

211 Fresh Food Temperature Offsets

Press the refrigerator temperature “+” (up) or “-” (down) keypad to toggle calibration of fresh food temperature plus or minus in 1°F increments up to 6°F.

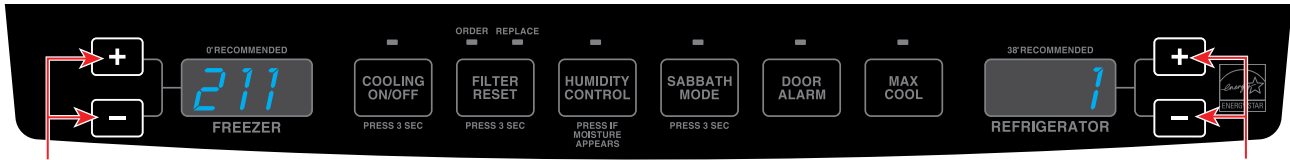

Press either button to toggle through test cycles

Press either button to change calibration of fresh food temperature plus or minus in 1° increments

Note: Temperature will read in fahrenheit regardless of what current temperature scale is being used.

212 Freezer Temperature Offsets

Press the refrigerator temperature “+” (up) or “-” (down) keypad to toggle calibration of freezer temperature plus or minus 1°F in increments up to 6°F.

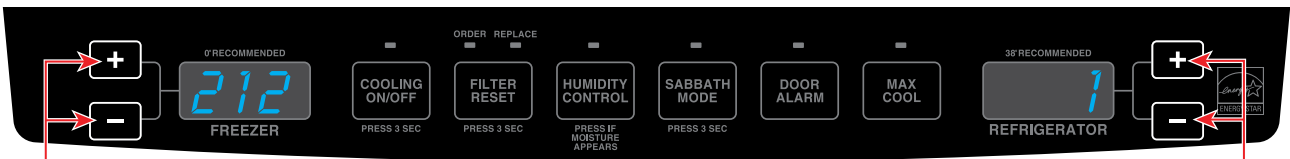

Press either button to toggle through test cycles

Press either button to change calibration of freezer temperature plus or minus in 1° increments

Note: Temperature will read in fahrenheit regardless of what current temperature scale is being used.

221 Reset Default Settings

(CAUTION: this will reset all adjustments made prior to this test)

Press the refrigerator temperature “+” up keypad to toggle reset to factory default settings dEF.

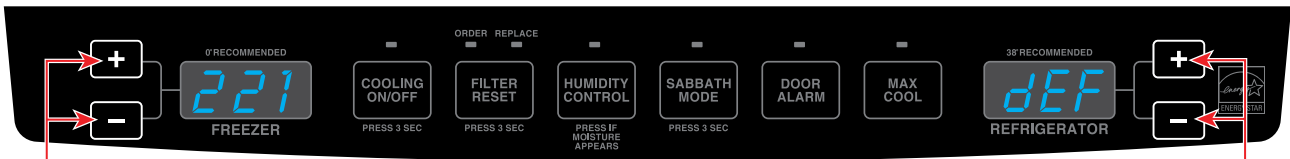

Press either button to toggle through test cycles

Press either button to reset to factory default (dEF)

Service Tests (continued)

231 Water Filter Usage

Display shows the percent water filter consumption since water filter was reset. 100% indicates the filter should be replaced.

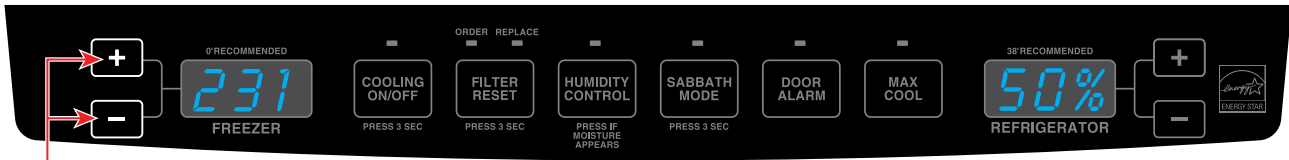

Press either button to toggle through test cycles

232 Water Filter Days In Use

The display shows the number of days since the water filter was reset.

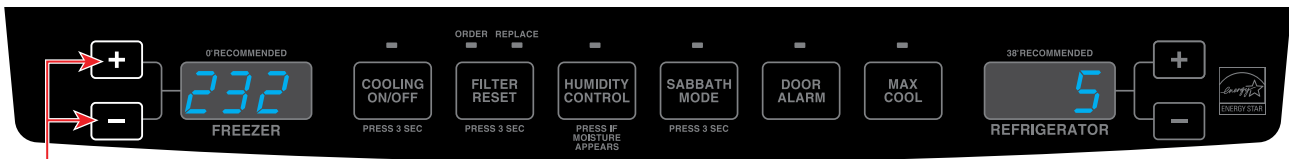

Press either button to toggle through test cycles

241 Software Revision Main Control Board

The display shows the software revision of the main control board.

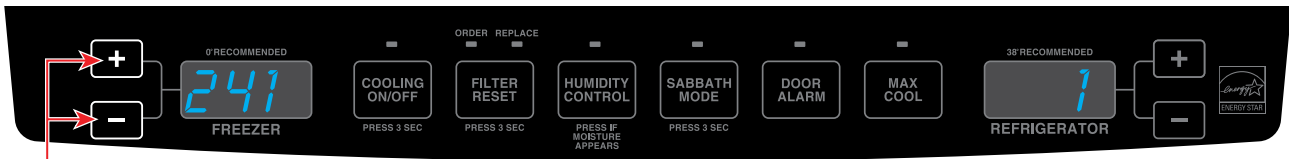

Press either button to toggle through test cycles

242 Software Revision Display Board

The display shows the software revision of the display board.

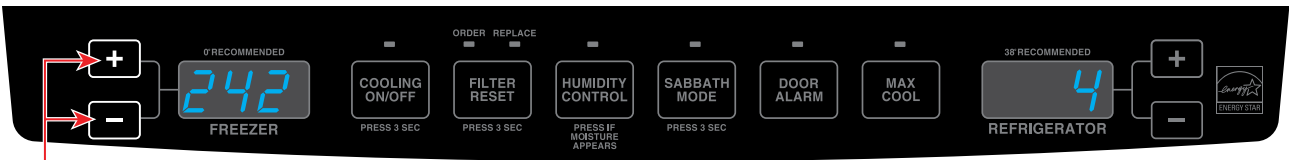

Press either button to toggle through test cycles

Note: Test Mode 301 and above are reserved for engineering use only.

Parts Location—Upper Control Board and Main Control Board

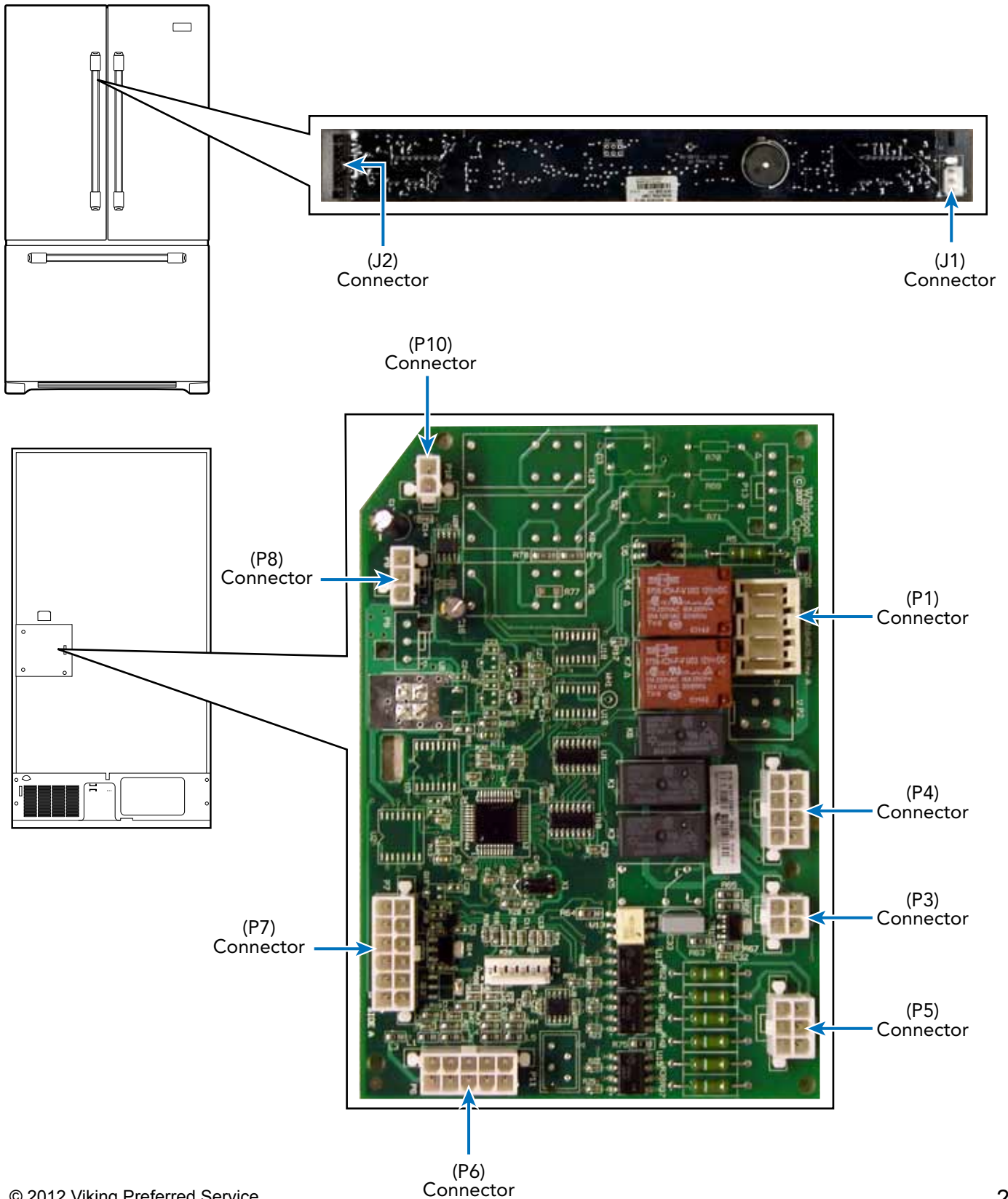

Parts Location—Secondary Control Board

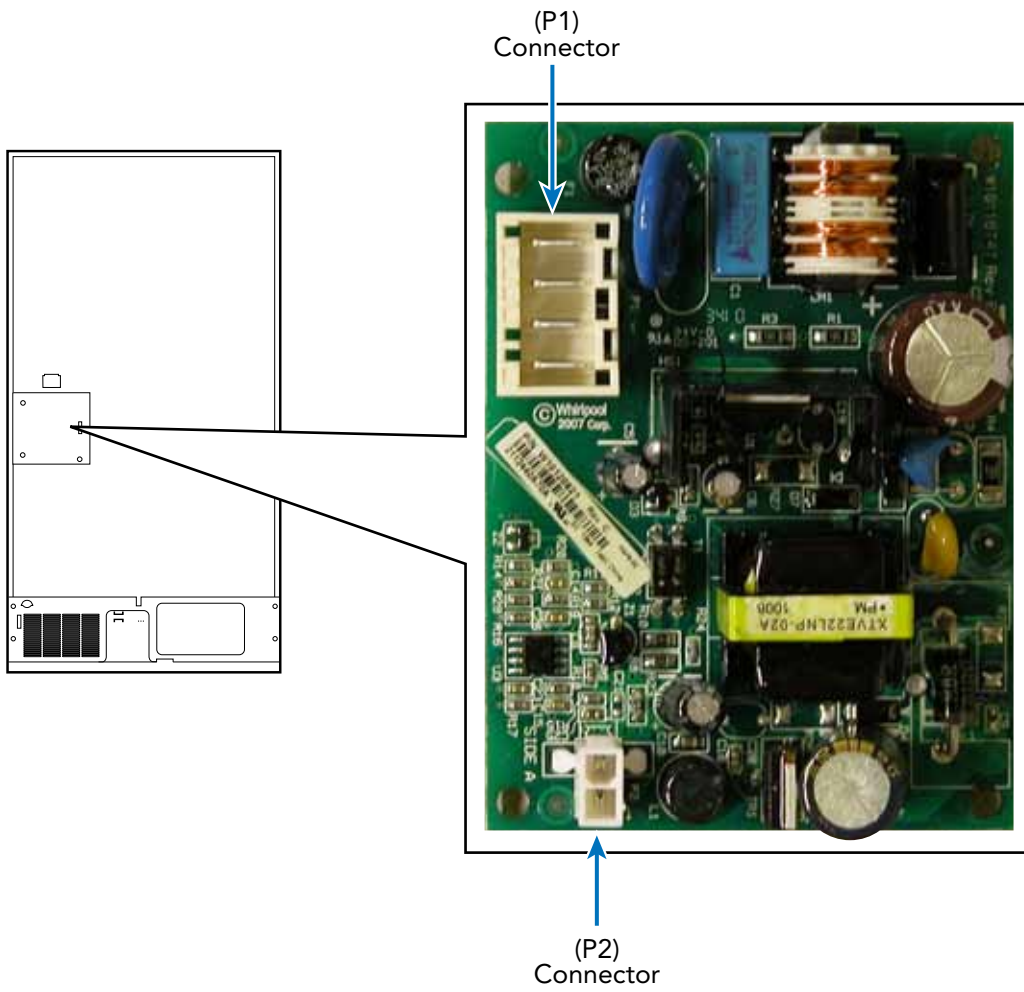

⚠ WARNING

To avoid risk of electrical shock, personal injury, or death, disconnect electrical power to unit using power switch before servicing. After servicing, reconnect power using power switch.

Component Testing

The unit has a main control board, a secondary control board and UI (dispenser) board that control functions of the respective refrigerator/freezer compartment. Components can be diagnosed via these boards. With the board accessed (refer to main and secondary control boards access procedure, page 52 and control board access procedure, page 32), the following can be measured:

Component Testing–Control Board

Component	Test Point	Reading
Defrost Terminator and Defrost Heater	P3-3 (Brown) – P1-2 (White)	55.7K Ω
Refrigerator Light Switch	P1-1 (Red) – P4-3 (Black)	1M Ω
Freezer Light and NC Freezer Light Switch	P1-1 (Red) – P5-1 (Red/Orange)	24.7 Ω
Defrost Terminator	P3-3 (Brown) – P5-6 (Orange)	55.7K Ω
Damper Motor	P5-5 (Blue/Red) – P1-2 (White)	1.4M Ω
Evaporator Fan	P3-1 (Black/Yellow) – P1-2 (White)	1M Ω
Common Damper Motor	P3-2 (Yellow/Red) – P1-2 (White)	–
Evaporator Fan and Defrost Heater	P3-1 (Black/Yellow) – P3-3 (Brown) Defrost Thermostat closed	55.8K Ω
Ice Maker	P1-1 (Red) – P1-2 (White)	100M Ω
Water Dispenser Switch	P6-3 (Yellow) – P6-8 (Yellow)	20K Ω
Normally Closed Motorized Damper	P5-5 (Blue/Red) – P1-2 (White)	∞ Ω
Fresh Food Thermistor	P6-6 (White/Blue) – P6-1 (White/Orange)	2.38K Ω
Freezer Thermistor	P6-7 (White/Yellow) – P6-1 (White/Orange)	2.38K Ω
Ambient Thermistor	P6-9 (White/Violet) – P6-1 (White/Orange)	2.38K Ω
Freezer Thermistor and Ambient Thermistor	P6-6 (White/Blue) – P6-9 (White/Violet)	4.5K Ω
Condenser Fan Motor and PTC Overload Relay	P1-4 (Blue) – P1-2 (White)	3.9 Ω
Condenser Fan Motor and PTC Overload Relay	P1-4 (Blue) – P1-2 (White)	3.9 Ω
Common Freezer Light Switch	P5-1 (Red/Orange) – P1-1 (Red)	3.2M Ω
Power Cord (Neutral)	P1-2 (White)	–
Mullion Heater	P7-9 (Blue/White) – P7-10 (Red/Black)	24.5 Ω
Mullion Heater	P7-9 (Blue/White) – P7-10 (Red/Black)	24.5 Ω
+14 VDC Display PC Board	P10-1 (Red/Black) – P10-2 (Black/Green)	5.6K Ω
Wide Display PC Board	P8-2 (Yellow/Black) – P8-3 (Black/Green)	–
Dig Ground PC Board	P8-3 (Black/Green)	–
Compound Ground and Base Pan Ground	Green/Yellow	–

Main Control Board Wiring Connections

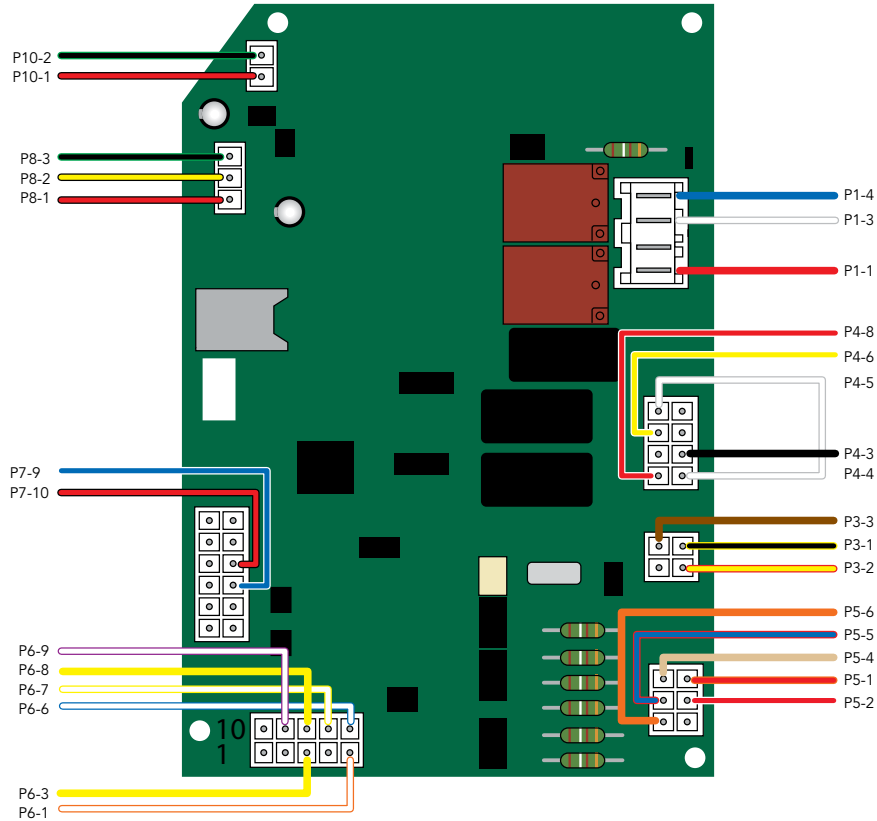

Pin Number	Description	Wire Color
P10-2	Dig Ground	Black/Green
P10-1	+14VDC	Red/Black
P8-3	Dig Ground	Black/Green
P8-2	Wide PCB	Yellow/Black
P8-1	+14VDC	Red/Black
P7-9	Trio Heater	Blue/White
P7-10	+14VDC	Red/Black
P6-9	Ambient Thermister	White/Violet
P6-8	Dispenser	Yellow
P6-7	Freezer Thermister	White/Yellow
P6-6	Fresh Food Thermister	White/Blue
P6-3	Dispenser	Yellow
P6-1	Thermister Ground	White/Orange

Pin Number	Description	Wire Color
P1-4	Compressor	Blue
P1-3	Neutral	White
P1-1	L1	Red
P4-8	L1	Red/White
P4-6	Dispenser Valve	Yellow/White
P4-5	Neutral	White
P4-3	Neutral	Black
P4-4	Neutral	White
P3-3	Defrost Thermostat	Brown
P3-1	Evaporator Fan	Black/Yellow
P3-2	Damper Motor	Yellow/Red
P5-6	Defrost Heater	Orange
P5-2	Damper NO	Blue/Red
P5-4	Ice Maker Valve	Tan
P5-1	FC Lite	Red/Orange
P5-2	RC Lite	Red/White

Secondary Control Board Wiring Connections

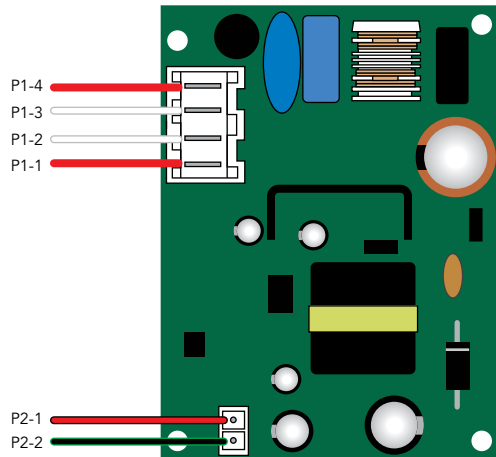

Pin Number	Description	Wire Color
P1-4	L1	Red
P1-3	Neutral	White
P2-2	Dig Ground	White
P1-1	L1	Red
P2-1	+14VDC	Red/Black
P2-2	Dig Ground	Black/Green

Parts Location—Refrigerator

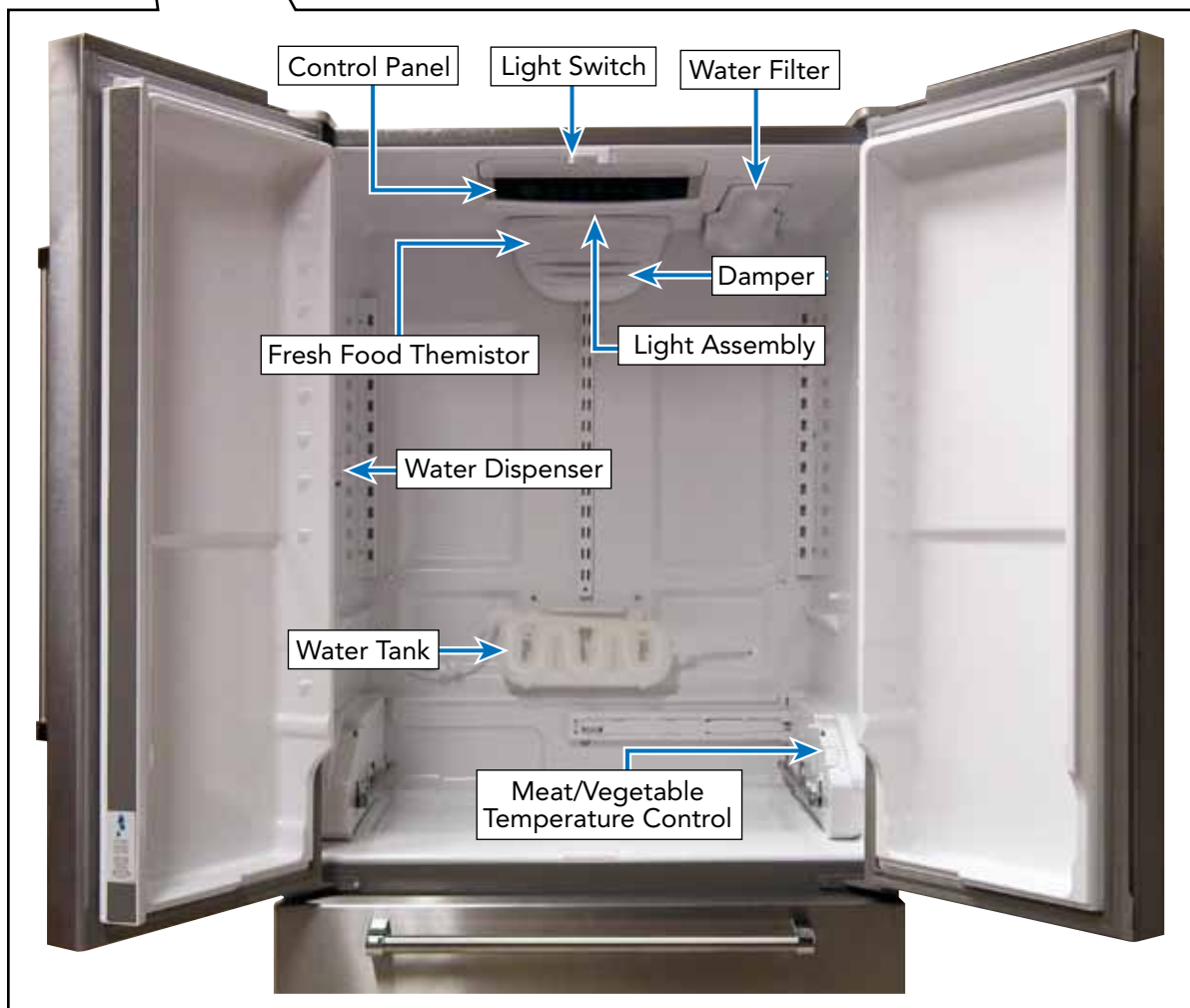
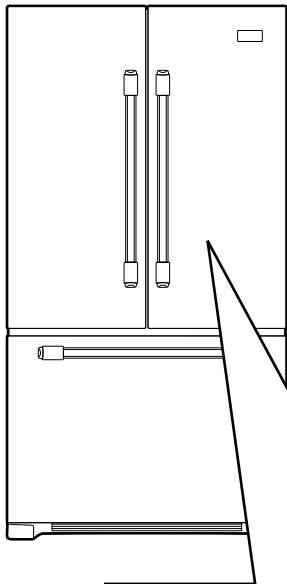

⚠ WARNING

To avoid risk of electrical shock, personal injury, or death, disconnect electrical power to unit using power switch before servicing. Wires removed during disassembly must be replaced on proper terminals to insure correct earth ground and polarization. After servicing, reconnect power using power switch.

Refrigerator Light Bulb

The unit uses standard 40W, 120 VAC light bulbs to illuminate the refrigerator compartment.

To access the light bulb:

1. Open fresh food door, loosen mounting screw and slide cover to rear to release holding tabs.



2. Replace light bulb.



3. Reverse procedure to reinstall cover.

Refrigerator Light Housing

To access light housing:

1. Open doors and remove shelves.
2. Remove light bulb cover and light bulbs (see Refrigerator Light Bulb section at left).
3. Using a screw driver, press tab on the right side of light housing and lower housing into refrigerator cabinet.



4. Disconnect wiring.

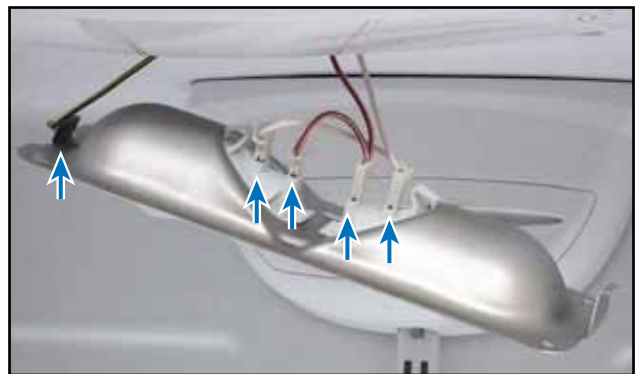

5. Replace or repair as necessary.
6. Reverse procedure to reinstall.

⚠ WARNING

To avoid risk of electrical shock, personal injury, or death, disconnect electrical power to unit using power switch before servicing. Wires removed during disassembly must be replaced on proper terminals to insure correct earth ground and polarization. After servicing, reconnect power using power switch.

Control Board

To access control board:

1. Open doors and remove shelves.
2. Remove light bulbs, (see Refrigerator Light Bulb section, page 30).
3. Insert a screwdriver blade into the slots to release the control board housing.

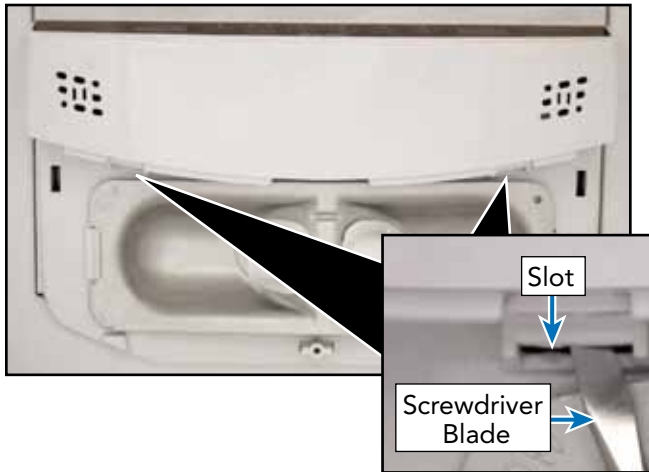

4. Drop down the control board housing and disconnect the wiring.

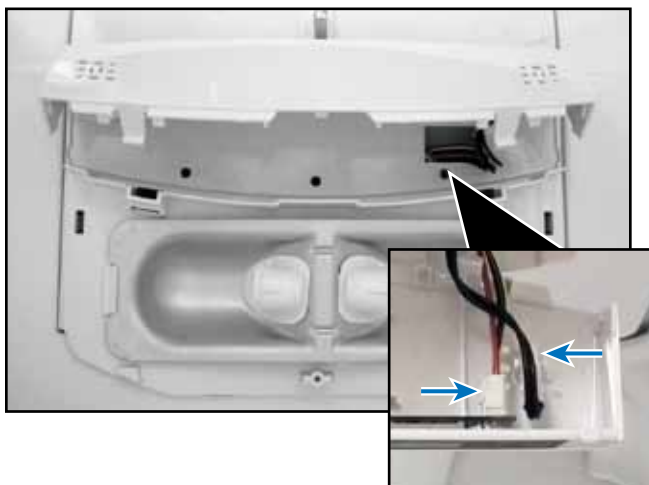

5. Disconnect wiring ribbon and press tabs to release control board from housing.

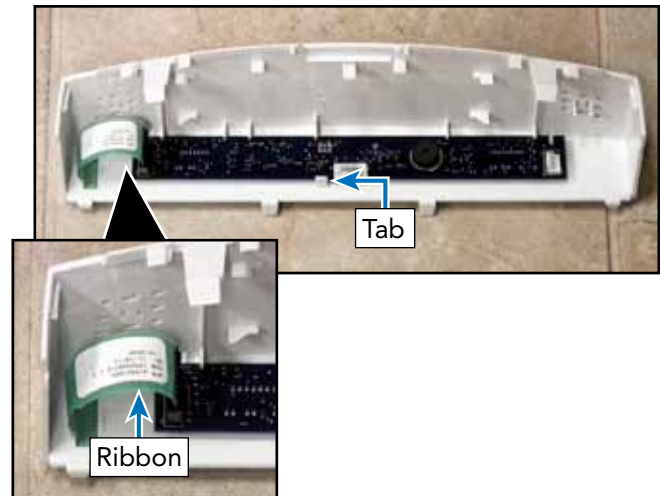

6. Replace or repair as necessary.
7. Reverse procedure to reinstall.

⚠ WARNING

To avoid risk of electrical shock, personal injury, or death, disconnect electrical power to unit using power switch before servicing. Wires removed during disassembly must be replaced on proper terminals to insure correct earth ground and polarization. After servicing, reconnect power using power switch.

Refrigerator Temperature Sensor

The unit uses a Thermistor(NTC - Negative Temperature Coefficient)) to sense refrigerator temperature.

To access temperature sensor:

1. Open doors and remove shelves.
2. Remove control board housing (see Control Board section, Steps 1-4, page 31).
3. Disconnect temperature sensor from control board housing.

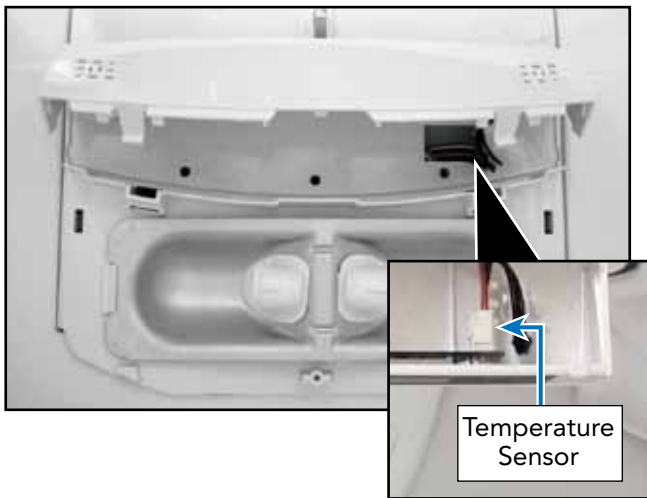

4. Replace or repair as necessary.
5. Reverse procedure to reinstall.

Vegetable/Meat Temperature Control

The unit has a slide control to regulate air flow into the vegetable/meat drawer.

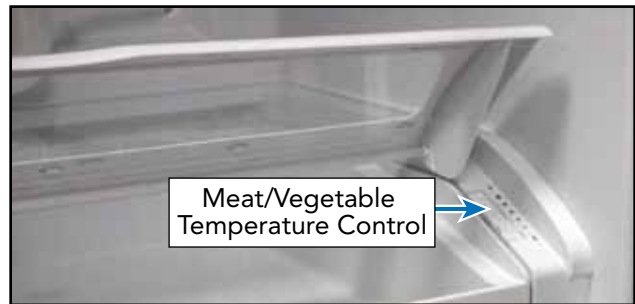

To access vegetable/meat temperature control:

1. Open doors and remove shelves and drawers.
2. Lift up on right tray guide to disengage from inner wall.



3. Rotate right tray guide to disengage clips, then remove temperature control and right tray guide.



4. Repair or replace as necessary.

⚠ WARNING

To avoid risk of electrical shock, personal injury, or death, disconnect electrical power to unit using power switch before servicing. Wires removed during disassembly must be replaced on proper terminals to insure correct earth ground and polarization. After servicing, reconnect power using power switch.

Refrigerator Light Switch

To access the refrigerator light switches:

1. Open door and locate the light switch.
2. Use a flat blade to depress light switch securing tabs.

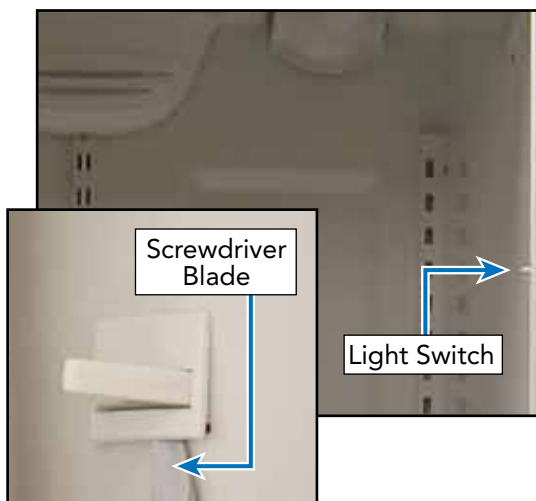

3. Pull switch into refrigerator compartment and disconnect wiring.

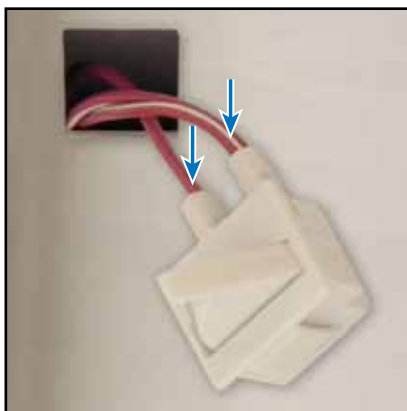

4. Repair or replace switch.
5. Reverse procedure to reinstall.

Water Tank

To access the water tank:

1. Open door and remove shelves and drawers.
2. Remove 1/4" screws securing water tank.

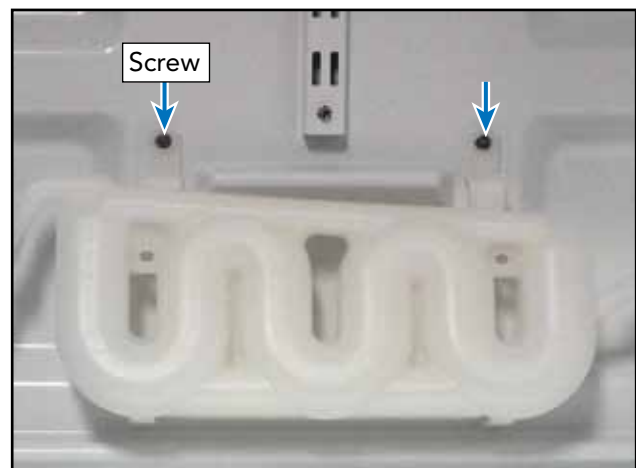

3. Disconnect tank and water lines.



4. Remove water tank.
5. Reverse procedure to reinstall.

WARNING

To avoid risk of electrical shock, personal injury, or death, disconnect electrical power to unit using power switch before servicing. Wires removed during disassembly must be replaced on proper terminals to insure correct earth ground and polarization. After servicing, reconnect power using power switch.

Water Dispenser

To access the water dispenser:

1. Insert a screwdriver blade and carefully remove the top cover of the dispenser.



2. Disconnect water line from dispenser assembly.



3. Press tabs to release switch from side panel. Disconnect wiring.

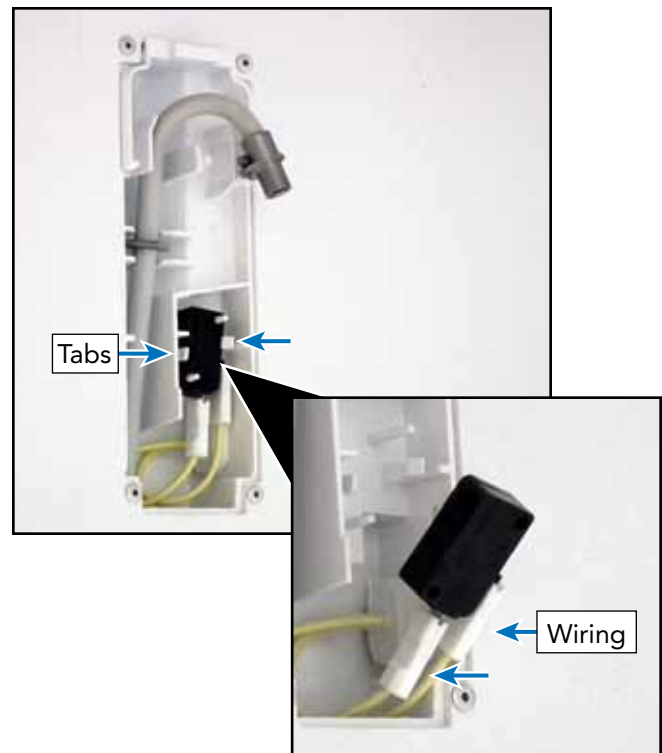

4. Replace or repair as necessary.
5. Reverse procedure to reinstall.

⚠ WARNING

To avoid risk of electrical shock, personal injury, or death, disconnect electrical power to unit using power switch before servicing. Wires removed during disassembly must be replaced on proper terminals to insure correct earth ground and polarization. After servicing, reconnect power using power switch.

Refrigerator Damper:

To access the refrigerator damper:

1. Open doors and remove shelves.
2. Remove louvered cover off of damper control.



3. Remove screws holding housing to rear wall and remove housing.

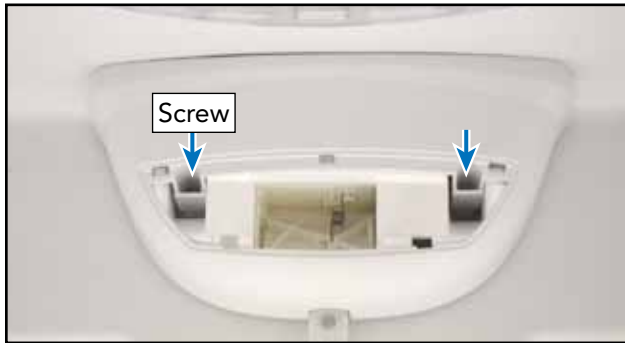

3. Disconnect wiring and remove damper.

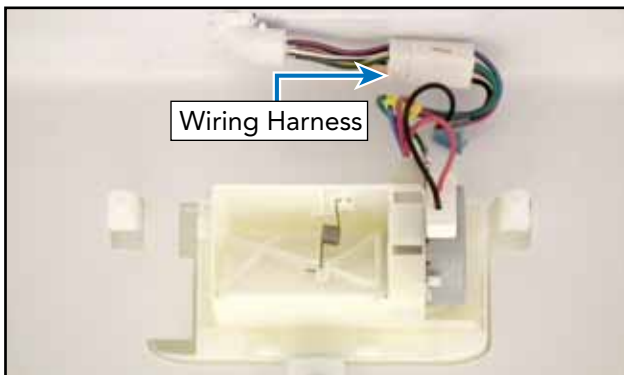

4. Replace or repair as necessary.
5. Reverse procedure to reinstall.

Water Filter

The unit has a water filter system designed to filter a flow rate of 0.78GPM and a maximum pressure of 120 PSI.

To access the water filter:

1. Open door(s), depress filter cover release, and lower filter cover.



2. Remove filter by turning counterclockwise.

Water Flow

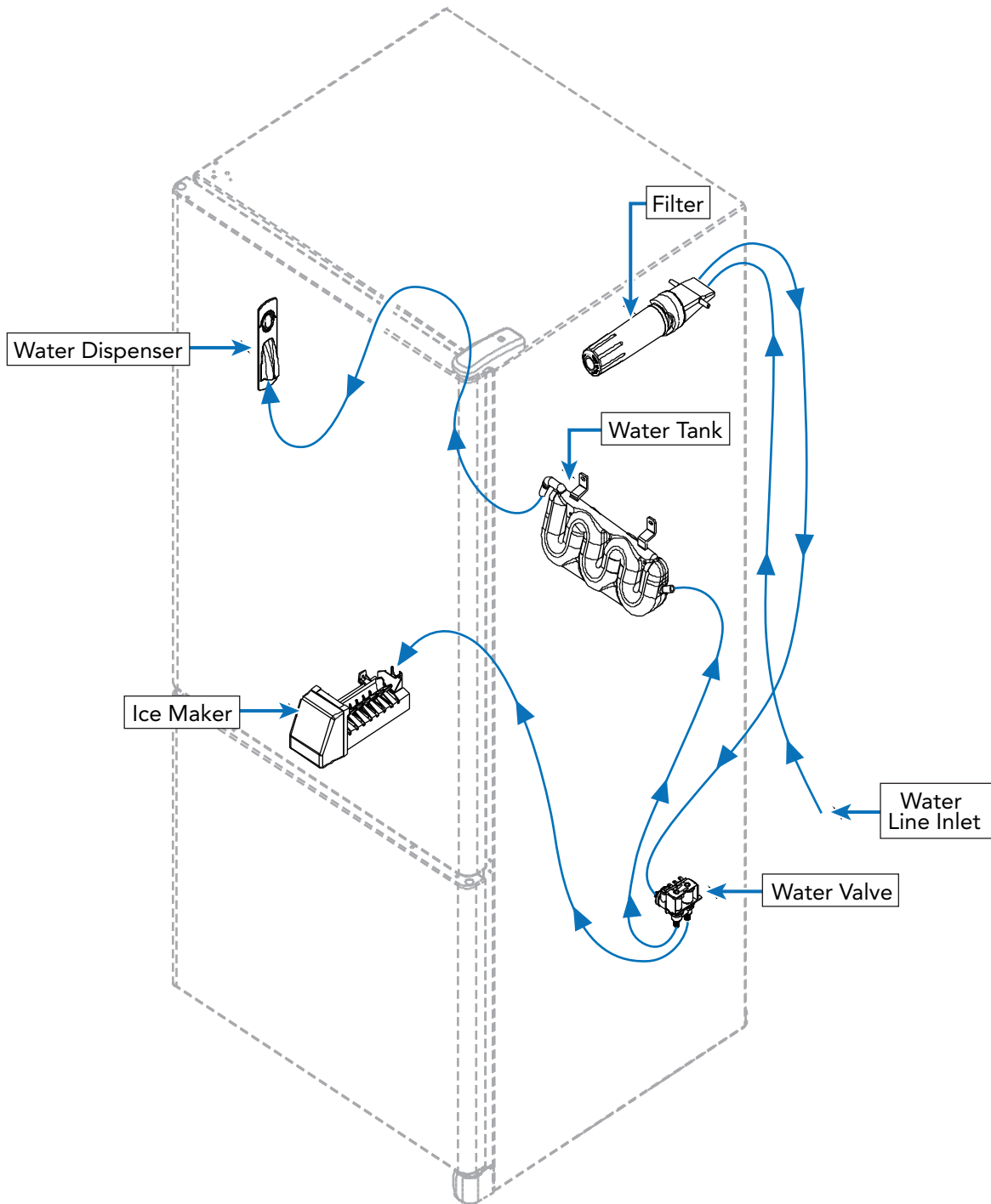

Parts Location–Freezer

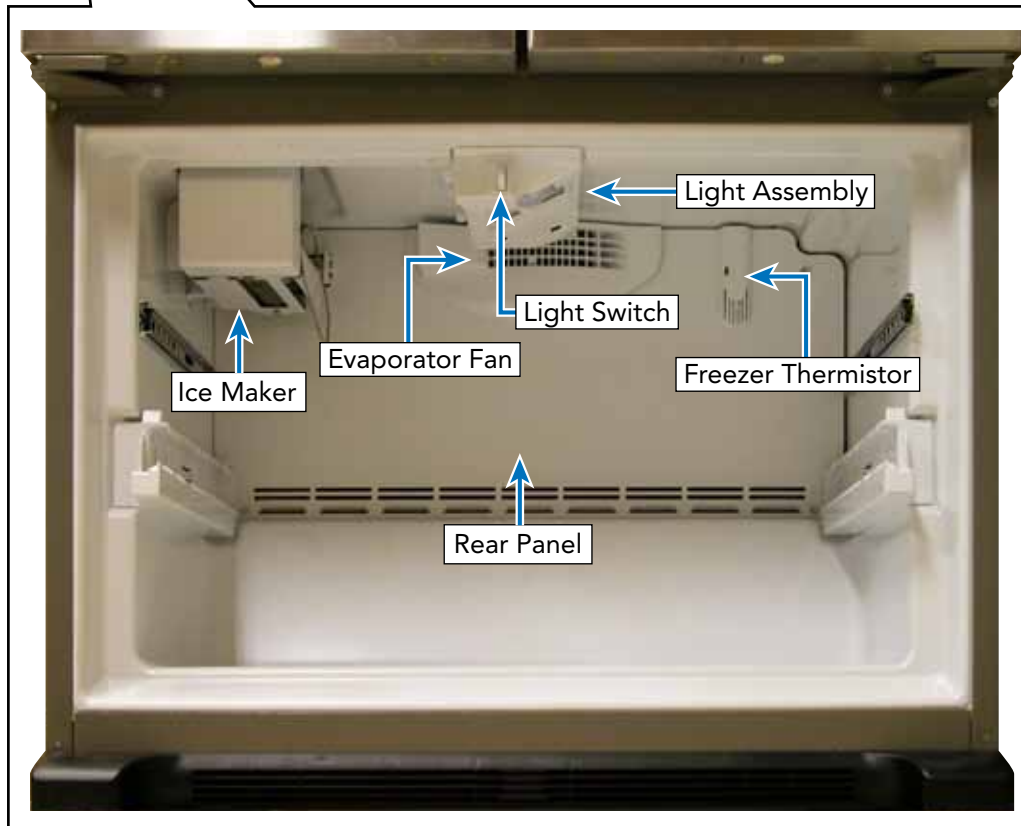
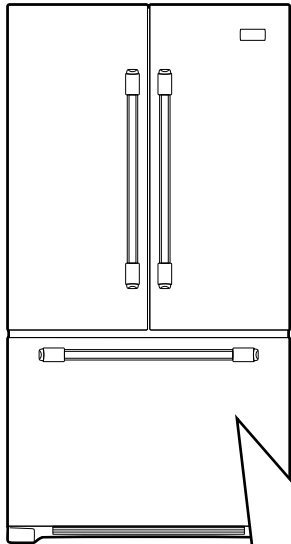

WARNING

To avoid risk of electrical shock, personal injury, or death, disconnect electrical power to unit using power switch before servicing. Wires removed during disassembly must be replaced on proper terminals to insure correct earth ground and polarization. After servicing, reconnect power using power switch.

Freezer Drawer Switch

To access the freezer drawer switch:

1. Open drawer.
2. Use a flat blade to depress light switch securing tab.

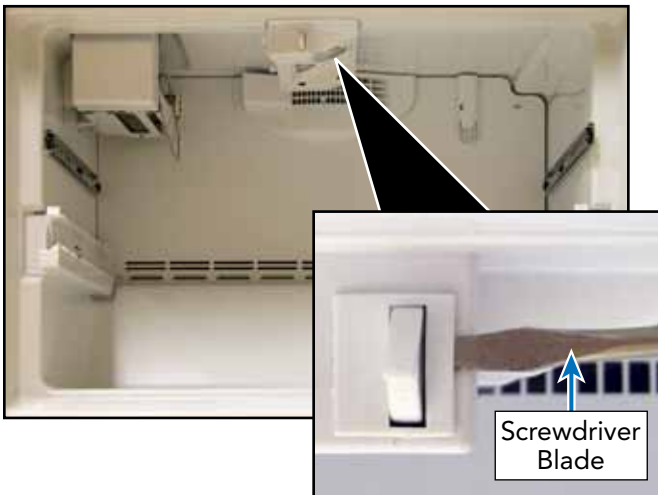

3. Pull switch into freezer compartment and disconnect wiring harness.

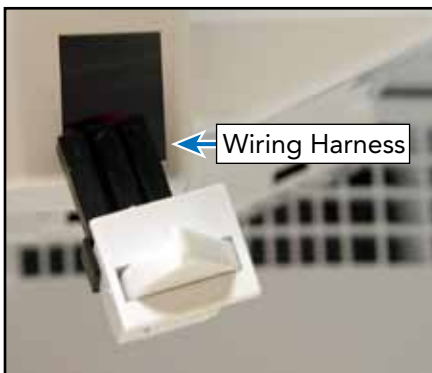

4. Repair or replace switch.
5. Reverse procedure to reinstall.

Freezer Light Bulb

The unit uses a standard 40W, 120 VAC light bulb to illuminate the freezer compartment.

To access the light bulb:

1. Open freezer drawer to replace light bulb.



Freezer Light Housing

To access light housing:

1. Remove freezer light bulb (see Freezer Light Bulb section above).
2. Insert a screwdriver blade into light housing to disengage tabs.

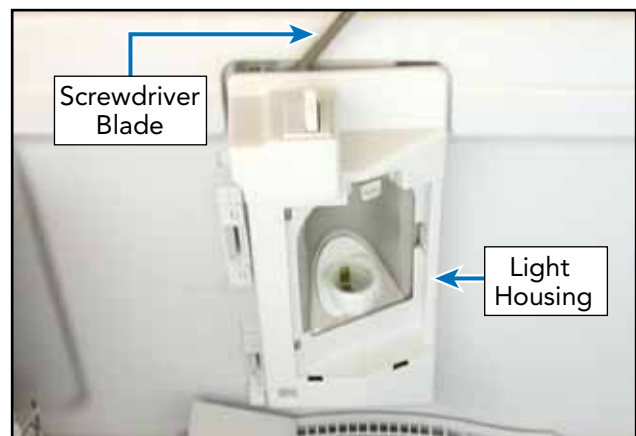

WARNING

To avoid risk of electrical shock, personal injury, or death, disconnect electrical power to unit using power switch before servicing. Wires removed during disassembly must be replaced on proper terminals to insure correct earth ground and polarization. After servicing, reconnect power using power switch.

Freezer Light Housing (continued)

3. Lower light housing, disconnect wiring harness, remove wiring connections and press tab to release light socket from housing.

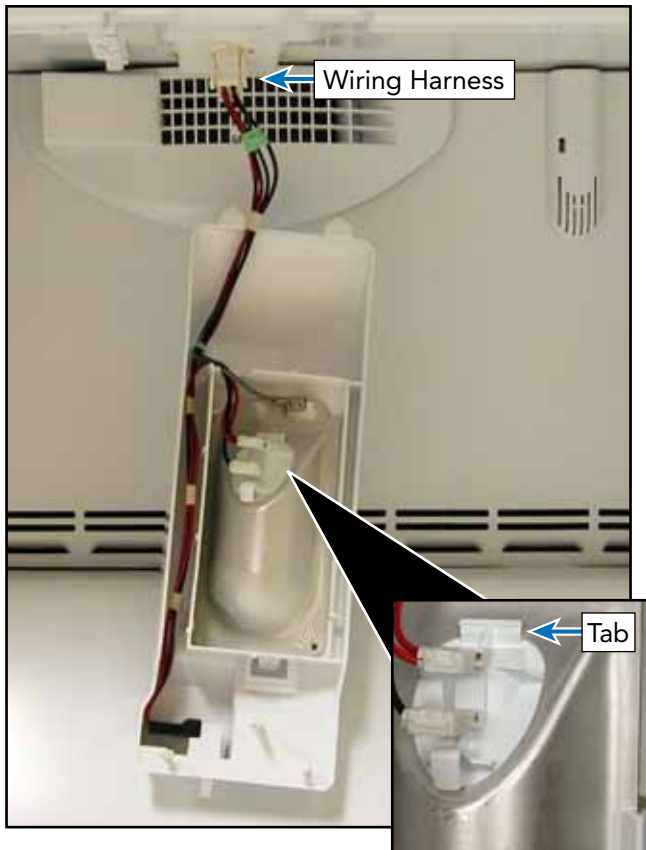

4. Replace or repair as necessary.
5. Reverse procedure to reinstall.

Freezer Drawer, Bins, Baskets, Glides and Glide Adapters

1. Open freezer drawer fully.



2. Lift up on the front of the lower basket to remove from freezer drawer.



WARNING

To avoid risk of electrical shock, personal injury, or death, disconnect electrical power to unit using power switch before servicing. Wires removed during disassembly must be replaced on proper terminals to insure correct earth ground and polarization. After servicing, reconnect power using power switch.

Freezer Drawer, Bins, Baskets, Glides and Glide Adapters (continued)

3. Grasp center bracket on lower bin and lift straight up to remove.

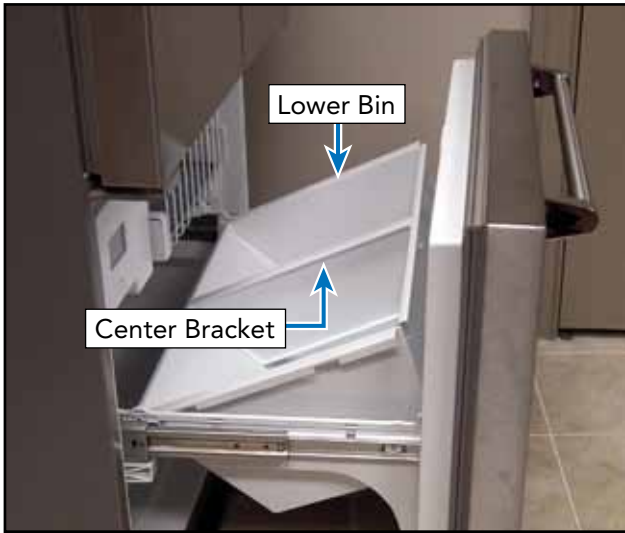

4. From underneath the upper basket and ice bin, press release clips inward on left and right glide adapters.

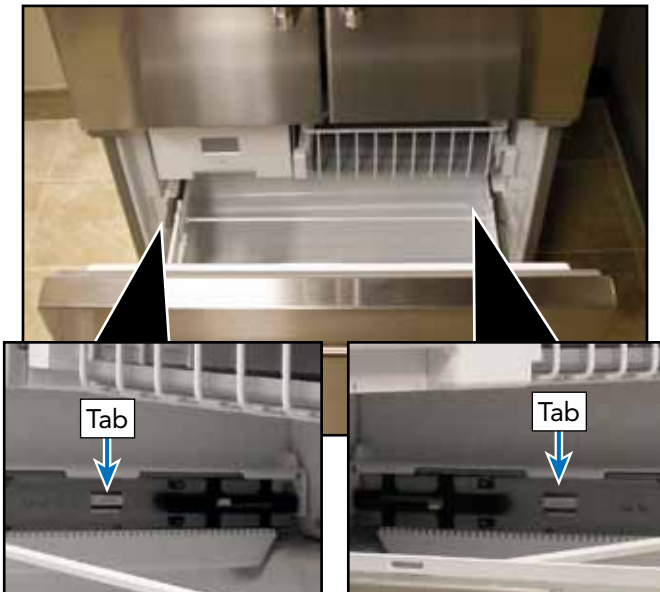

5. Pull door and drawer slides forward to remove.



6. Pull out upper basket. Press release clips on left and right glides. Pull the upper basket forward to remove.

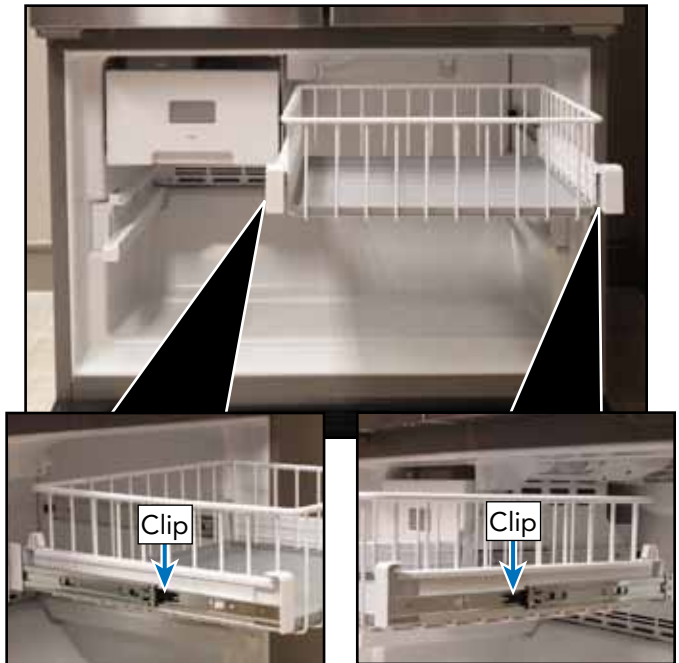

⚠ WARNING

To avoid risk of electrical shock, personal injury, or death, disconnect electrical power to unit using power switch before servicing. Wires removed during disassembly must be replaced on proper terminals to insure correct earth ground and polarization. After servicing, reconnect power using power switch.

Freezer Drawer, Bins, Baskets, Glides and Glide Adapters (continued)

7. Pull out ice maker tray. Press release clips inward on left and right glides. Pull ice maker tray forward to remove.

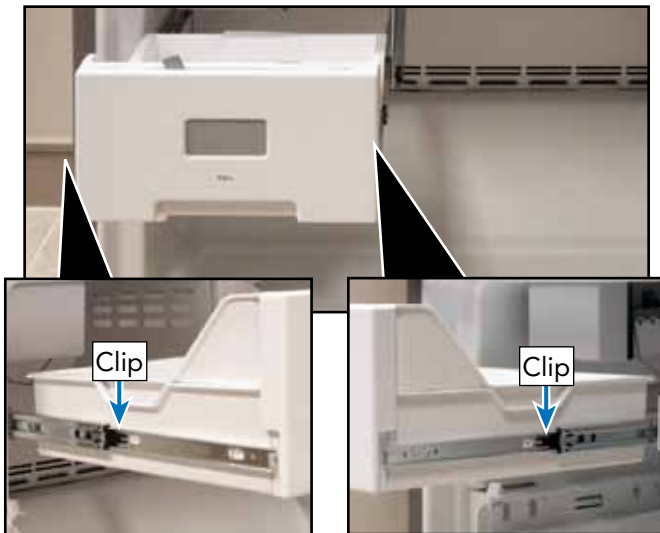

10. Extend left upper glide. Remove securing screws to remove glide.

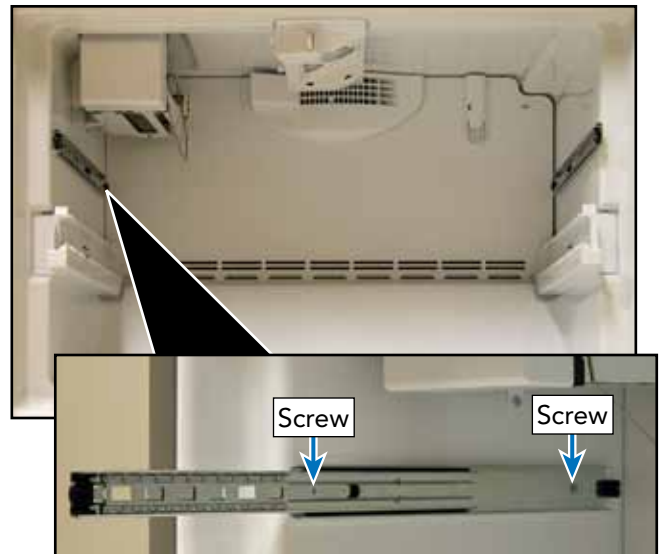

8. Remove screw from center upper drawer glide bracket.

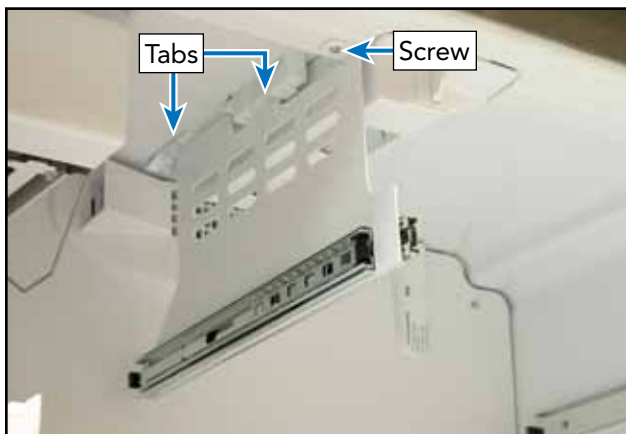

11. Extend right upper glide. Remove securing screws to remove glide.

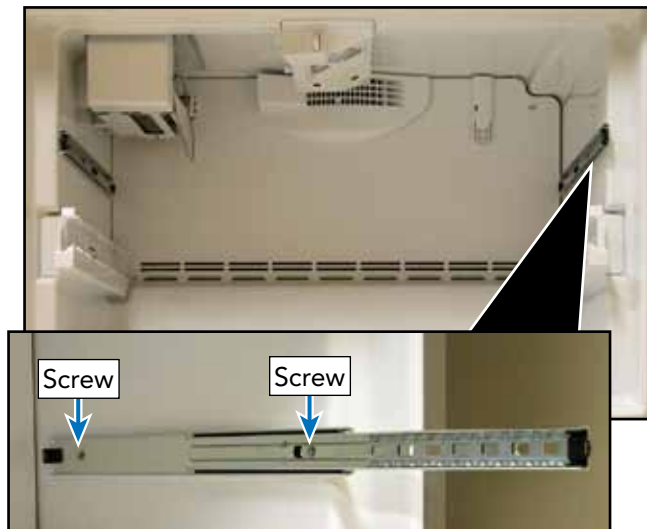

9. Push bracket towards rear of freezer to disengage tabs and remove center upper bracket.

⚠ WARNING

To avoid risk of electrical shock, personal injury, or death, disconnect electrical power to unit using power switch before servicing. Wires removed during disassembly must be replaced on proper terminals to insure correct earth ground and polarization. After servicing, reconnect power using power switch.

Freezer Drawer, Bins, Baskets, Glides and Glide Adapters (continued)

12. Remove securing screws to remove left and right lower basket glide adapters.

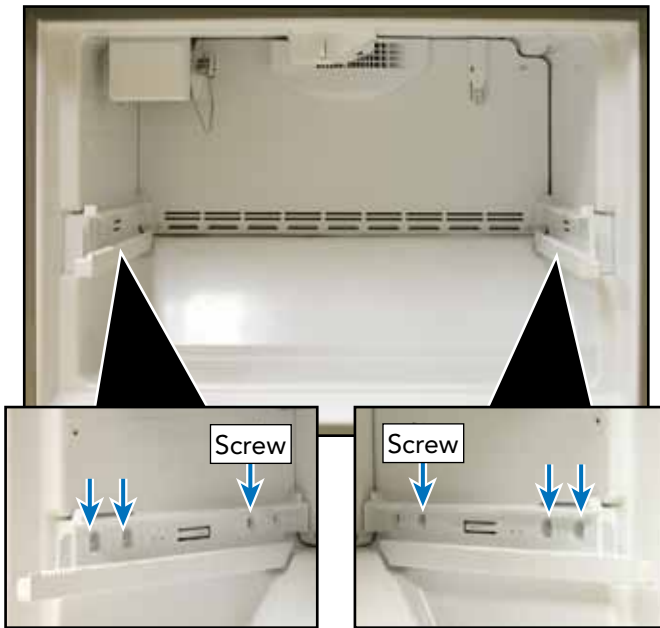

13. Replace or repair as necessary.
14. Reverse procedure to reinstall.

Ice Maker (shown here with cover off)



The unit uses an ice maker that consists of a mold heater, thermostat, motor, and wire harness. The ice maker always starts from and stops at the “park” position. In the park position (the ejector blades are pointing horizontally towards the back of the ice maker). Just before reaching the park position the mold is filled with water. At the park position all electrical components are de-energized, even though the shut-off arm is down, and the ice maker is ready for the next freeze cycle. The ice maker takes from 30 minutes to one hour to freeze the water. The primary time factors are the temperature in the freezer and the amount of airflow around the ice maker. Colder freezer settings and free air space around the ice maker to let air circulate will help make ice faster. After the ice forms, the ice maker continues to wait until it reaches 15°F before it starts the harvest cycle. This ensures that the ice is solid in all the cavities. At 15°F the thermostat closes, the mold heater turns on, and the ejector blades rotate up and forward until they stall out against the ice. The motor is designed to stall out and is geared to generate a lot of pressure. This minimizes the amount of melting needed to extract the ice. As soon as the ice is loose enough to move, the ejector pushes the ice out of the mold during the second half of the first revolution. During the second revolution, the ejector pushes the ice into the bucket.

⚠ WARNING

To avoid risk of electrical shock, personal injury, or death, disconnect electrical power to unit using power switch before servicing. Wires removed during disassembly must be replaced on proper terminals to insure correct earth ground and polarization. After servicing, reconnect power using power switch.

Ice Maker (continued)

Just before the ejector completes the second revolution, the ice maker turns the water valve ON for approximately 7 seconds and refills the mold with approximately 4 ounces of water and the freezing cycle is ready to begin again.

1. To access the ice maker, open the freezer door, remove bottom cover and the ice maker is accessible.
2. To access module, motor, and support assembly, loosen screws securing ice maker to bracket.



3. Lift ice maker from bottom to clear tabs. Disconnect shutoff arm, disconnect wiring harness and remove mold from bracket.



4. Remove securing screws.

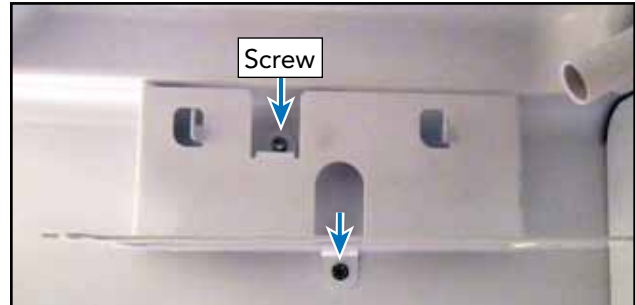

5. Lift the bracket up and toward the front of the freezer to disengage the bracket tabs and remove the bracket.
6. To access module, motor, and support assembly, loosen screws in module access ports, disconnect shutoff arm, disconnect wiring harness and remove mold from support assembly.

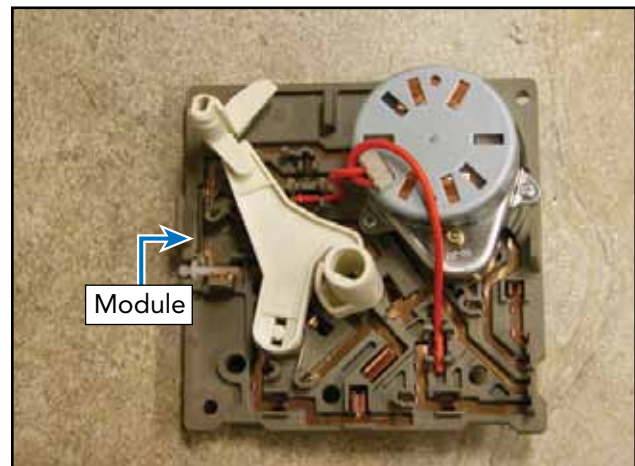

⚠ WARNING

To avoid risk of electrical shock, personal injury, or death, disconnect electrical power to unit using power switch before servicing. Wires removed during disassembly must be replaced on proper terminals to insure correct earth ground and polarization. After servicing, reconnect power using power switch.

Ice Maker (continued)

To make ice, an ice maker needs power, water, and sub-freezing temperatures.

Note: The freezer door switch turns OFF power to the ice maker when the freezer door is open. It will be necessary to manually close the freezer door switch for some troubleshooting steps. Ensure that the shut off arm is down and instruct customer on its use if necessary.

To ensure power to the ice maker without a meter, remove the module cover and take note of the test points.

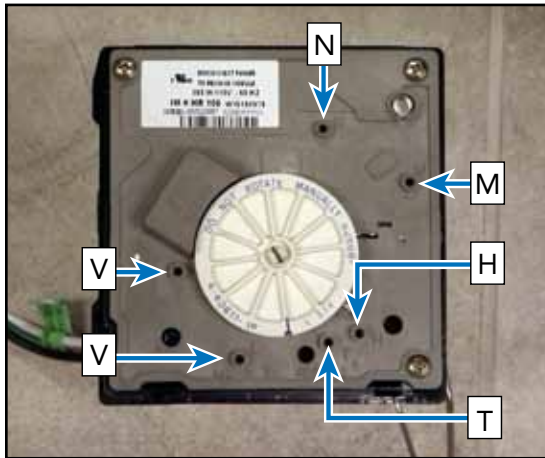

Test Point	Component
N	Neutral side of line
M	Motor connection
H	Heater connection
T	Thermostat connection
L	L1 side of line
V	Water valve connection

Place a 14-gauge jumper wire across test points T and H. With hands clear of the ice maker, manually close the freezer door switch. This will put the ice maker in a manual cycle. If the ejector does not rotate, this indicates no power to the ice maker. Trace power from the wall socket to the door switch and to the connector. Repair circuit and connections or replace door switch as needed. If the ejector begins to rotate (very slowly), there is power. With power present, verify 0 VAC between test points T and H (this verifies the thermostat has closed). Verify heater resistance is approximately 264 Ω. With motor running, verify heater is heating. If no heat is detected, replace mold assembly. Next ensure water is supplied to the ice maker. When the ejector blade gets to the 11 o'clock position, the water valve is energized for 7.5 seconds.

Verify the water valve has 120 VAC between test points V and N and approximately 4.75 ounces of water is dispensed. If voltage is present and water is not dispensed, verify water supply and fill rate. **CAUTION:** DO NOT use a Reverse Osmosis Water Filtration system. It reduces the water pressure below 20 psi and the ice maker will not fill. Use of a Reverse Osmosis system will void the warranty. Poor water quality can cause ice maker to fail or produce unacceptable cubes. Install a water filter to eliminate bad taste, odor, and visible contaminants. Mineral content or sand can restrict screen in water fill valve or particles of sand can keep valve from seating properly.

If water valve does not operate properly, the following could occur: no ice production, small or hollow ice cubes, flooding of ice container. Mineral content can cause lime build up in the mold, wicking of water over the mold and poor

⚠ WARNING

To avoid risk of electrical shock, personal injury, or death, disconnect electrical power to unit using power switch before servicing. Wires removed during disassembly must be replaced on proper terminals to insure correct earth ground and polarization. After servicing, reconnect power using power switch.

Ice Maker (continued)

cube release. Mineral content can also restrict saddle valves. Verify water supply line is ON, water pressure is not below 20 psi, saddle valve is fully open and clear of restrictions. Fully close and open valve to dislodge sediment (if necessary, remove valve and enlarge pierced hole to 3/16" diameter with a drill and reinstall saddle valve). Ensure water line to unit is not pinched/kinked/or clogged, ice is not present in inlet tube blocking water flow, or water pressure is not above 120 psi.

Water fill can be increased by turning the adjustment screw counterclockwise and decreased by turning the screw clockwise. One-half turn will adjust the fill by approximately two thirds of an ounce. If supply is OK replace water valve. If no voltage is present, verify harness. If OK, replace module.

The TCO is a safety device and must NOT be bypassed. If the TCO is found to be electrically open, this indicates an overheat in the ice maker and the ice maker must be replaced.

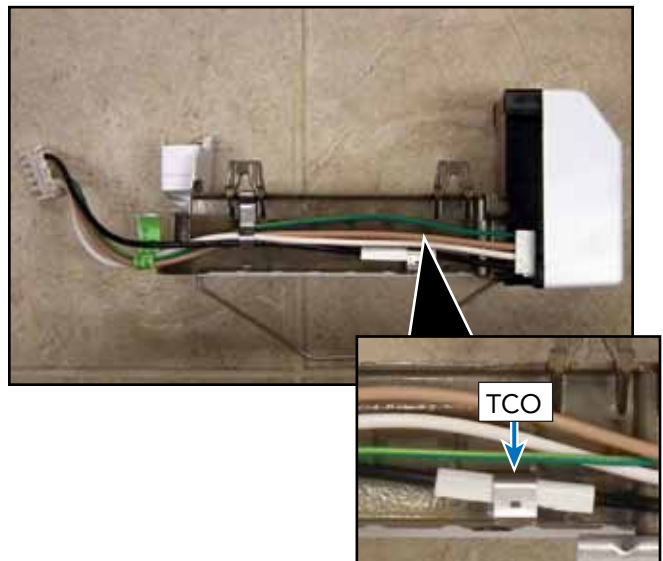

Component Testing–Ice maker Thermal Cut Out (TCO)

Module Ohmmeter Checks with No Power to Ice maker and Ejector Blades in End of Cycle			
Test Points	Component	Module Position	Ohms
L-H	Mold & Heater	Attached to Support	264
L-M	Motor	Separate from Heater	16,100

Module Voltage Checks with Motor or Test Light Power to Ice maker			
Test Points	Component	Line Voltage	0 Volts
T-Module	Power ON	Power OFF	Power OFF
T-H	Bimetal	Open	Closed
L-H	Heater	ON	OFF
L-M	Motor	ON	OFF
N-V	Water Valve	ON	OFF

WARNING

To avoid risk of electrical shock, personal injury, or death, disconnect electrical power to unit using power switch before servicing. Wires removed during disassembly must be replaced on proper terminals to insure correct earth ground and polarization. After servicing, reconnect power using power switch.

Freezer Thermistor

To access freezer thermistor:

1. Remove freezer drawer, baskets, and glide adapters (see Freezer Drawer, Baskets, Bins Glides and Glide Adapters section, pages 39-42).
2. Remove thermistor cover from evaporator cover.
3. Remove thermistor from thermistor cover.
4. Remove evaporator cover (see Evaporator Cover section, page 47).
5. Disconnect wiring.

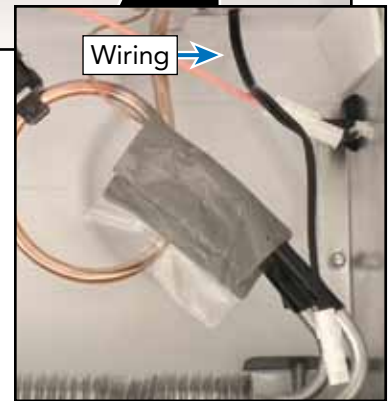
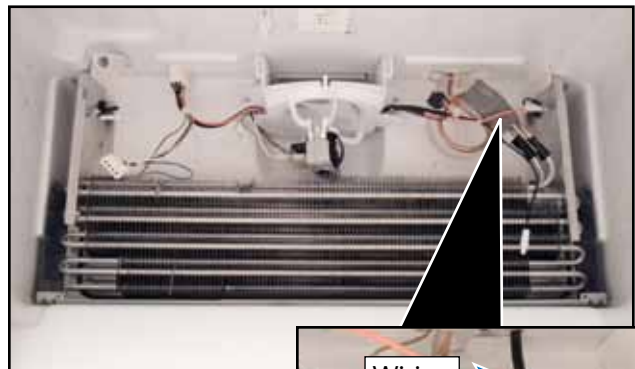
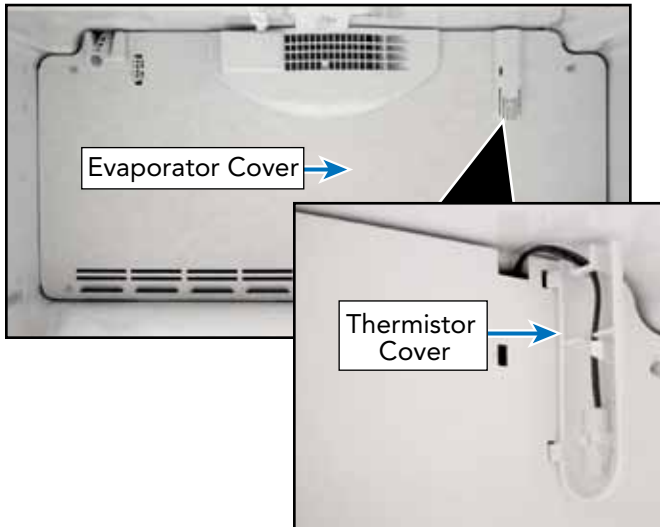

3. Remove thermistor from thermistor cover.

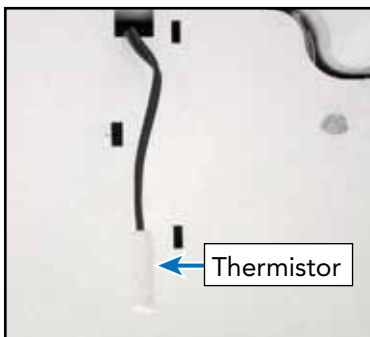

6. Repair or replace thermistor.
7. Reverse procedure to reinstall.

⚠ WARNING

To avoid risk of electrical shock, personal injury, or death, disconnect electrical power to unit using power switch before servicing. Wires removed during disassembly must be replaced on proper terminals to insure correct earth ground and polarization. After servicing, reconnect power using power switch.

Evaporator Cover

1. Remove freezer drawer, baskets, and glide adapters (see Freezer Drawer, Baskets, Bins Glides and Glide Adapters section, pages 39-42).
2. Remove freezer thermistor cover (see Freezer Thermistor section, page 46).
3. Remove evaporator fan cover.

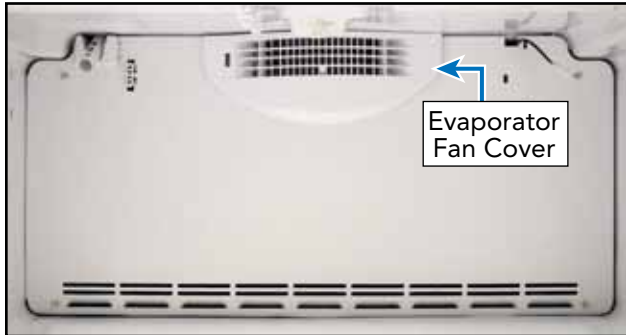

4. Remove securing screws, wiring harness and evaporator cover.



With the evaporator cover removed, the evaporator fan, the freezer thermistor, defrost heater, and defrost thermostat are accessible.

5. Reverse procedure to reinstall.

Evaporator Fan

The unit uses a fan motor to pull air over the evaporator coil and circulate it throughout the unit.

Evaporator Fan access:

1. Remove freezer drawer, baskets, and glide adapters see Freezer Drawer, Baskets, Bins Glides and Glide Adapters section, pages 39-42).
2. Remove evaporator cover (see Evaporator Cover section at left).
3. Remove securing screws.

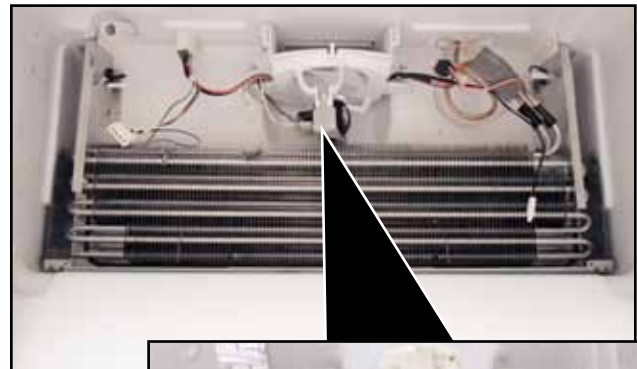

⚠ WARNING

To avoid risk of electrical shock, personal injury, or death, disconnect electrical power to unit using power switch before servicing. Wires removed during disassembly must be replaced on proper terminals to insure correct earth ground and polarization. After servicing, reconnect power using power switch.

Evaporator Fan (continued)

4. Disconnect wiring and unclip thermostat.

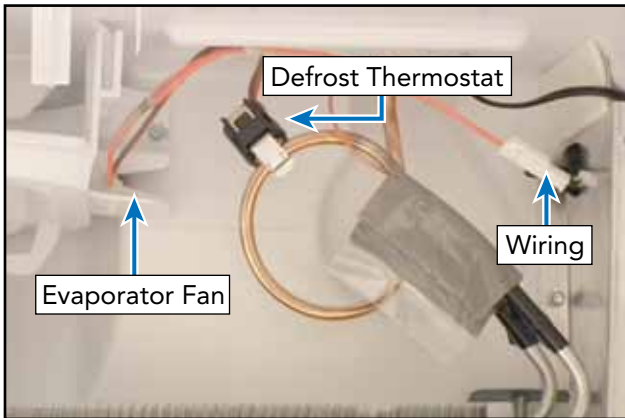
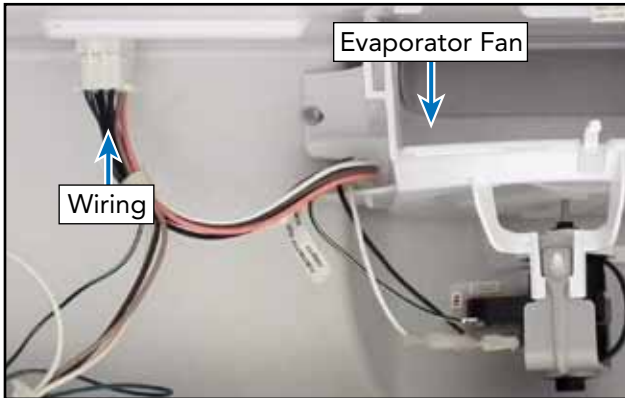

5. Repair or replace fan.
6. Reverse procedure to reinstall.

Defrost Heater

The unit uses a heater to help remove ice buildup during the defrost cycle. When the defrost terminator closes, voltage is supplied to the heater via the control board.

To access defrost heater:

1. Remove freezer drawer, baskets, and glide adapters see Freezer Drawer, Baskets, Bins Glides and Glide Adapters section, pages 39-42).
2. Remove thermistor cover (see Freezer Thermistor section, page 46).
3. Remove evaporator cover (see Evaporator Cover section, page 47).
4. Remove securing screws.

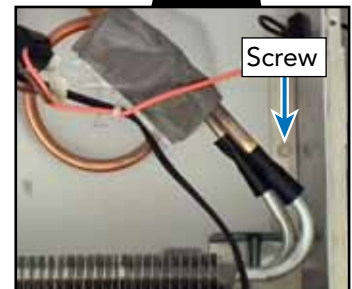
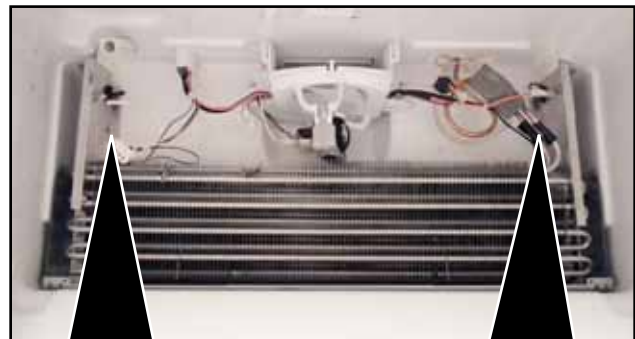

⚠ WARNING

To avoid risk of electrical shock, personal injury, or death, disconnect electrical power to unit using power switch before servicing. Wires removed during disassembly must be replaced on proper terminals to insure correct earth ground and polarization. After servicing, reconnect power using power switch.

5. Disconnect wiring on both ends of heater.

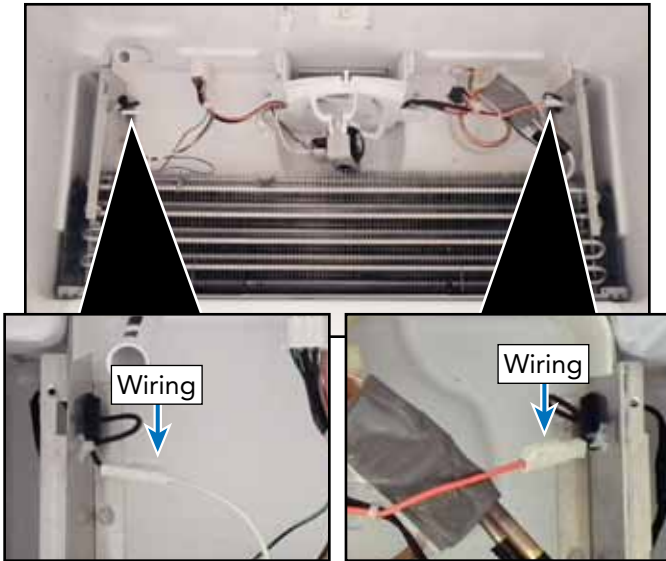

6. Release clips to remove heater.

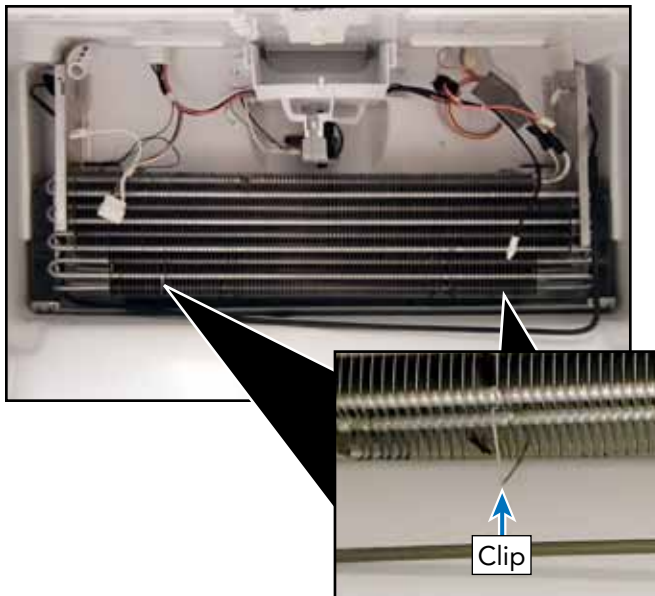

7. Repair or replace defrost heater.
8. Reverse procedure to reinstall.

Defrost Thermostat

The defrost terminator is a bimetal switch that is normally open. When the temperature drops below $20^{\circ}\text{F} \pm 5^{\circ}$, the defrost thermostat closes. This will allow voltage to flow to the defrost heater.

Once the freezer section reaches $42^{\circ}\text{F} \pm 7^{\circ}$, the terminator opens and power to the heater is broken.

To access defrost thermostat:

1. Remove freezer drawer, baskets, and glide adapters see Freezer Drawer, Baskets, Bins Glides and Glide Adapters section, pages 39-42).
2. Remove evaporator cover (see Evaporator Cover section, page 47).
3. Disconnect wiring and unclip thermostat.

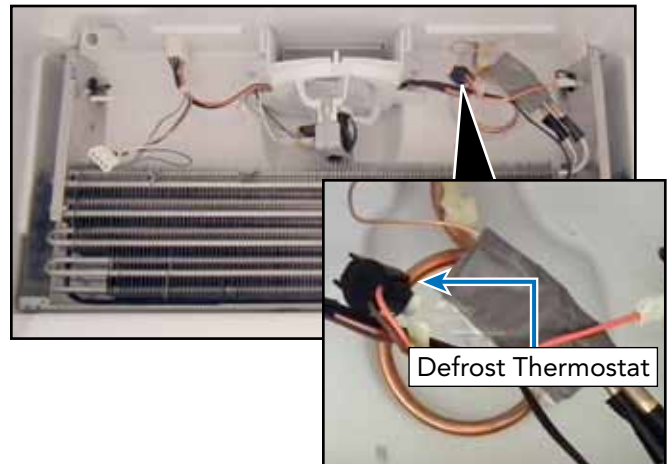

4. Repair or replace defrost thermostat.
5. Reverse procedure to reinstall.

Parts Location–Rear

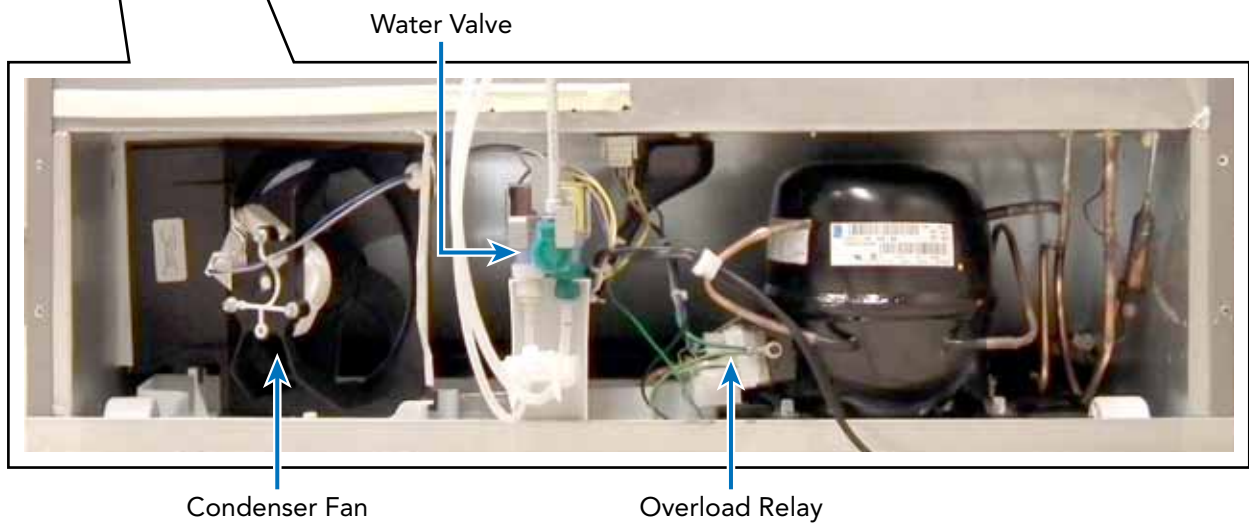
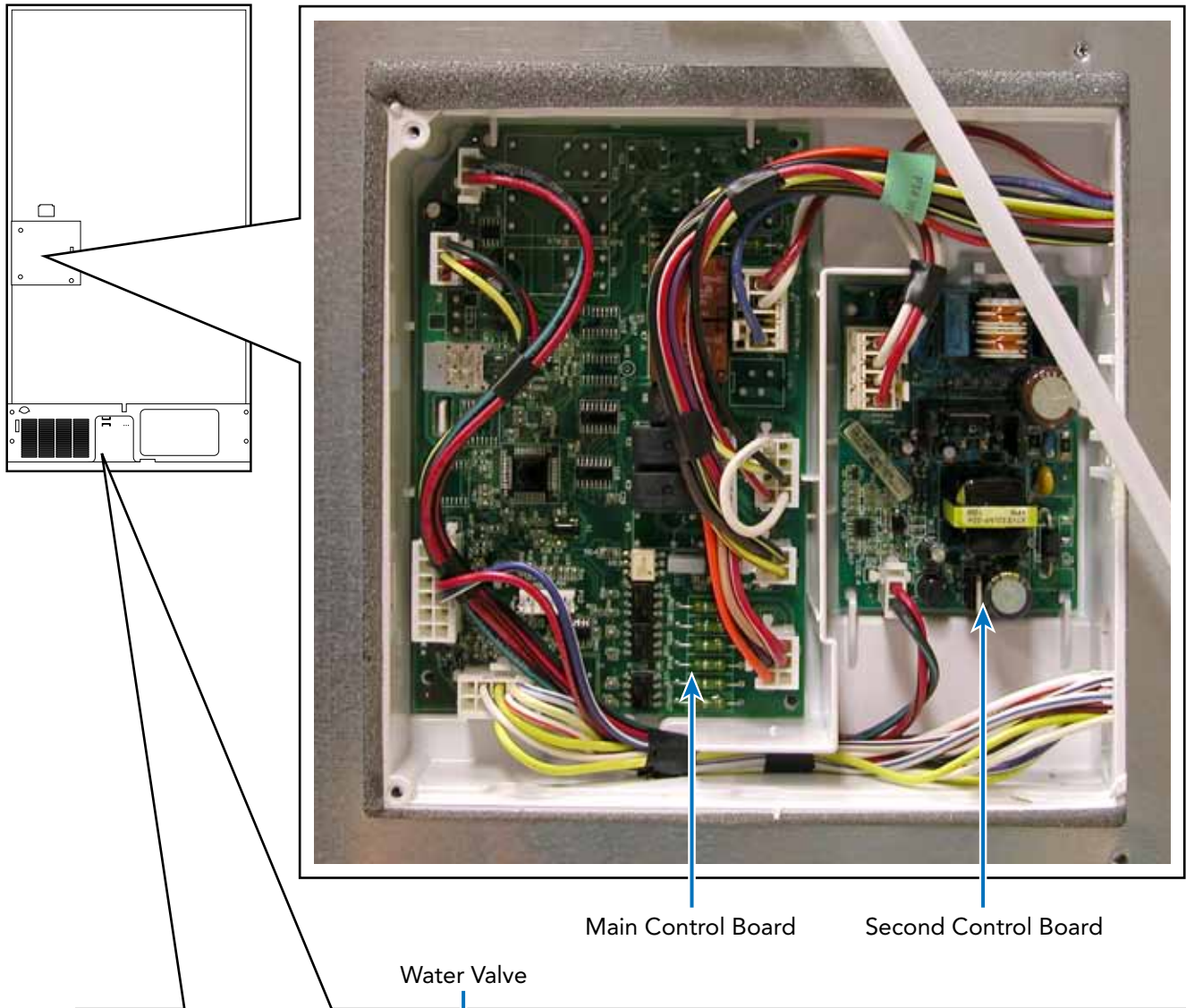

WARNING

To avoid risk of electrical shock, personal injury, or death, disconnect electrical power to unit using power switch before servicing. Wires removed during disassembly must be replaced on proper terminals to insure correct earth ground and polarization. After servicing, reconnect power using power switch.

Main and Secondary Control Boards

To access main and secondary control boards:

1. Remove securing screws and outer control board cover.

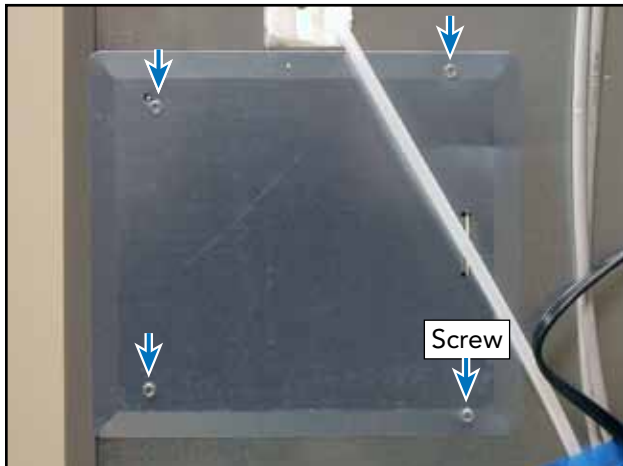

2. Lift off the clear control board cover.



3. Disconnect wiring. Press tab to release main or secondary control board.

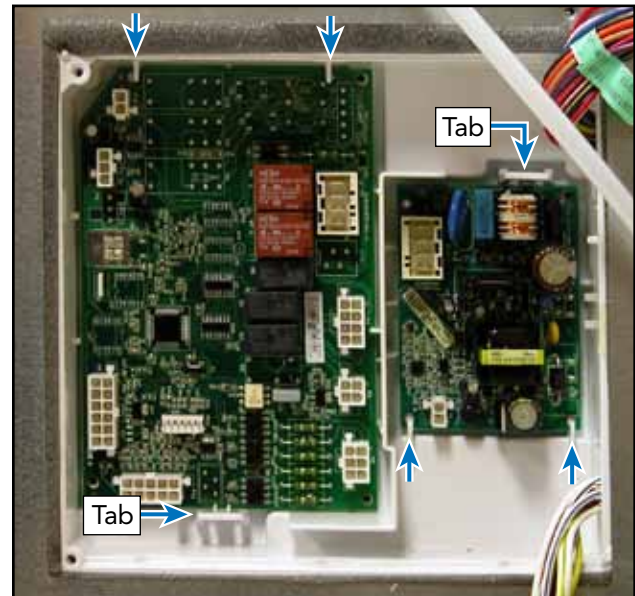

4. Repair or replace control boards.
5. Reverse procedure to reinstall.

⚠ WARNING

To avoid risk of electrical shock, personal injury, or death, disconnect electrical power to unit using power switch before servicing. Wires removed during disassembly must be replaced on proper terminals to insure correct earth ground and polarization. After servicing, reconnect power using power switch.

Overload Relay

To access overload relay:

1. Slide unit out for service. Remove securing screws.

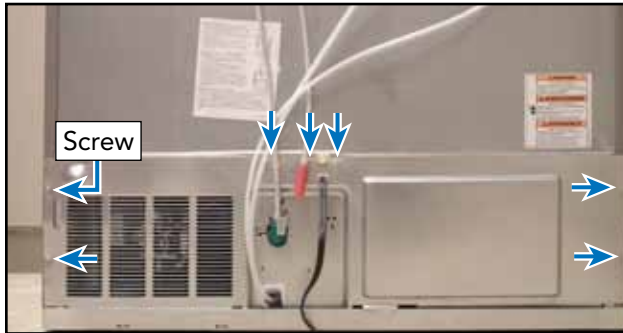

2. Disconnect water valve wiring (see Water Valve section, Step 4, Page 53. Remove lower panel.
3. Remove metal clip, disconnect wiring and remove relay from bracket.

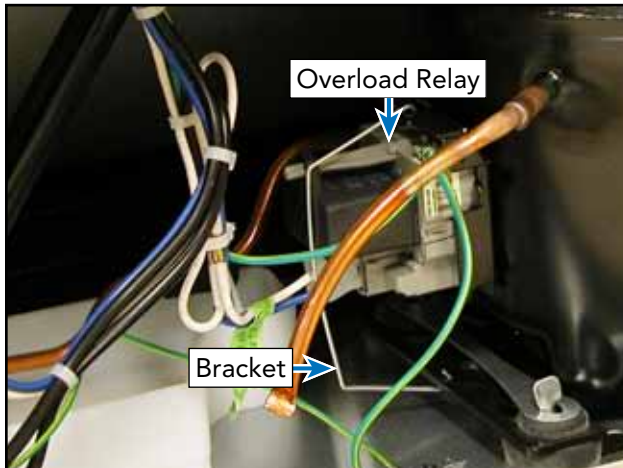

4. Repair or replace overload relay.
5. Reverse procedure to reinstall.

Condenser Fan

The condenser fan is used to provide airflow across the condenser coil and assist in the removal of heat from the condenser coil. It is also used to protect the compressor from overheating.

1. Slide unit out of service. Remove securing screws and lower rear cover (see Overload Relay section at left, Steps 1 and 2).
2. Remove condenser fan securing screws and disconnect wiring.

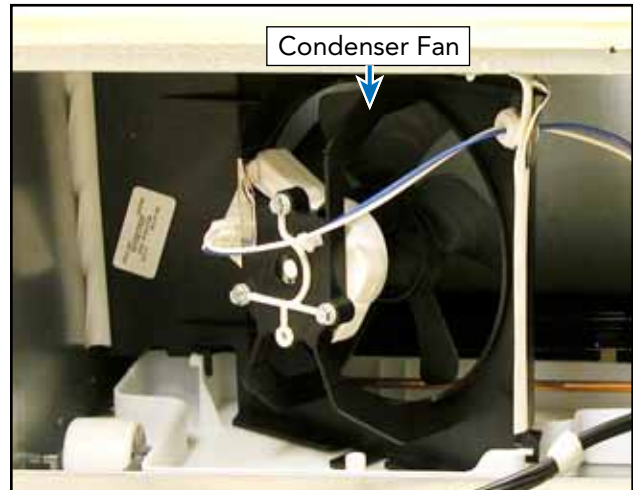

3. Repair or replace condenser fan.
4. Reverse procedure to reinstall.

⚠ WARNING

To avoid risk of electrical shock, personal injury, or death, disconnect electrical power to unit using power switch before servicing. Wires removed during disassembly must be replaced on proper terminals to insure correct earth ground and polarization. After servicing, reconnect power using power switch.

Water Valve

To access overload relay:

1. Slide unit out for service. Remove securing screws and lower rear cover (see Overload Relay section, Step 1, page 52).
2. Remove water valve retaining screw and slide dual tube sweep out of back cover.

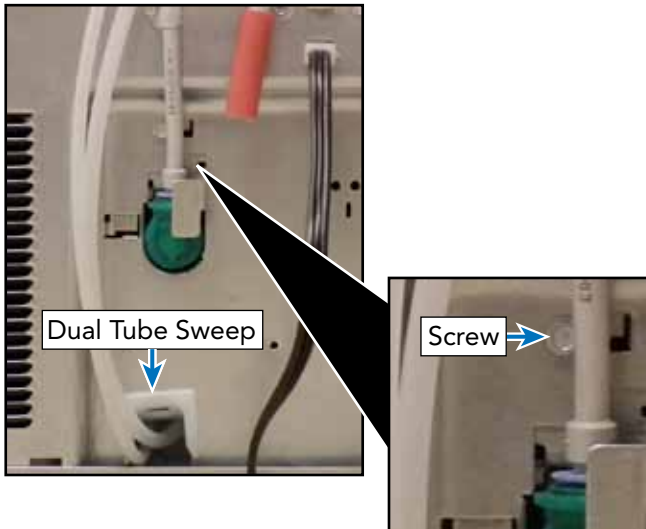

4. Disconnect water valve electrical connections.

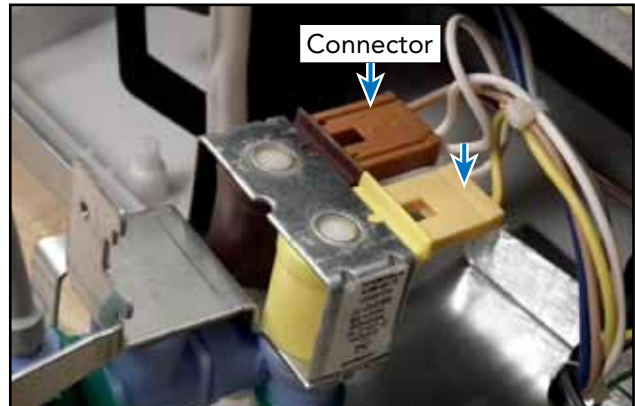

3. Repair or replace water valve.
4. Reverse procedure to reinstall.

3. Disconnect water lines.

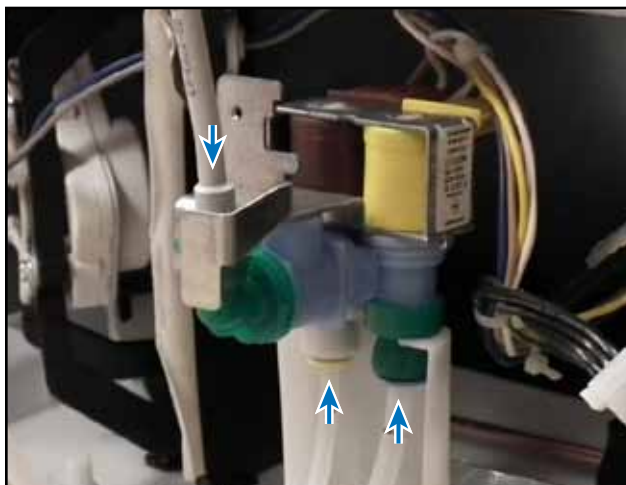

Troubleshooting Guide

Below are some general guides should a problem be detected. Please refer to the test procedures in this manual to determine the defective component.

Problem	Probable Cause	Correction
Unit will not operate	Power supply Circuit breaker Power switch	Verify voltage Reset breaker Turn to the "ON" position
Unit runs continually	Control setting Door seal Dirty condenser Condenser/evaporator fan Control board Heat exchanger	Move to medium setting Verify closure, replace if needed Clean condenser coil Verify movement/operation of fan Verify operation Verify heat exchanger has not separated
Frost on evaporator	Defrost thermostat Evaporator fan Defrost heater Door seal	Check indicator Check connection and possible short/open condition Verify operation and ohm heater Verify closure, replace if needed
Unit running and no lights	Sabbath Mode Open circuit	Take out of Sabbath Mode Replace control board Replace light switch Replace light bulb

Power Problems	Probable Cause	Correction
No power to ice maker at connector socket	No continuity	Determine discontinuity by tracing power
No power to water valve	No continuity	Determine discontinuity by tracing power

Water Problems	Probable Cause	Correction
No water to refrigerator	Supply Supply line Water valve	Turn on supply Look for obstructions in line Look for obstruction in valve Verify valve operation
No water to ice maker	Supply Supply line Water valve	Turn on supply Look for obstructions in line Look for obstruction in valve Verify valve operation
Clogged water valve	Water valve	Replace water valve
Insufficient water to ice maker (with correct fill time)	Restriction in supply line Water Valve	Remove restriction Repair or replace water valve

Troubleshooting Guide (continued)

Water Problems	Probable Cause	Correction
Low water pressure at supply	Low water pressure	Increase water pressure to 20 – 120 PSI
Low water pressure at water valve	Restrictions in line	Remove restrictions
Excessive water pressure	High water pressure	Install pressure regulator and set to 60 PSI
Low water fill volume	Ice maker fill setting Obstructions Water valve	Adjust water fill screw at ice maker Clear obstructions in supply line or supply valve Replace water valve
Excessive water fill volume	Ice maker fill setting Water pressure Water valve Ice maker	Adjust water fill screw at ice maker Reduce water pressure Replace water valve Replace ice maker
Water overflows fill cup	Fill tube Obstruction	Reposition fill tube in fill cup Remove obstruction in fill cup
Water overflows mold	Ice maker fill setting Water pressure Water valve Ice maker Unit or ice maker not level	Adjust water fill screw at ice maker Reduce water pressure Replace water valve Replace ice maker Level ice maker or refrigerator
Leaky water valve	Connections Water valve	Tighten connections Replace water valve

Temperature Problems	Probable Cause	Correction
Refrigerator too warm	Control setting Door seal Airflow Condenser/evaporator fan	Move control to medium setting Verify closure, replace if needed Ensure airflow is not obstructed Verify movement/operation of fan
Refrigerator too cold	Control setting Control board Airflow	Move control to medium setting Verify proper operation Verify airflow is proper
Freezer too warm	Control setting Door seal Dirty condenser Condenser fan Control board Defrost heater Thermistor	Move control to medium setting Verify closure, replace if needed Clean condenser coil Verify operation and no obstructions Verify operation Verify operation Verify operation
Freezer too cold	No continuity	Determine discontinuity by tracing power

Troubleshooting Guide (continued)

Temperature Problems	Probable Cause	Correction
Freezer too cold	Temperature setting Defrost thermostat Control board Thermistor	Move to medium setting Verify thermostat is closing Verify operation Verify operation

Ice Maker Problems	Probable Cause	Correction
Ice maker will not operate	Freezer too warm Shut off arm Water valve Water supply	Verify freezer temperature Verify the arm is in the "ON" position Verify valve operation Verify water supply
Jammed cubes (small or oversized cubes)	Unit/ice maker not level Water fill not proper	Level ice maker or unit Adjust water fill level
Hollow cubes	Low water in mold (Thermostat short cycle) Unit/ice maker not level Obstructions in fill tube Low water pressure Clogged filter	Replace ice maker thermostat Level ice maker or unit Remove obstructions in fill tub end Remove obstructions in fill tube Replace filter
Ice build-up on ejector blades	Hollow cubes Ice maker froze up Fill level	See hollow cubes above Remove ice maker and allow to thaw Adjust water fill level
Cubes falling back into mold during ejection	Small cubes Fill cup displaced	Check fill level Align fill cup
Raised shut-off arm	Shut-off arm in "OFF" position	Lower shut-off arm to "ON" position
Broken or bent shut-off arm	Shut-off arm Ice maker housing broken	Repair /Replace shut-off arm Replace ice maker
Shut-off arm stuck or obstructed	Shut-off arm obstructed	Remove obstruction
Ice maker not level	Unit not level Ice maker not level	Level unit Level ice maker
Thermostat defective	Thermostat	Replace thermostat
Ice stuck-Heater not working	Defective heater	Replace ice maker
Won't cycle test with power available	Ice maker	Refer to ice maker test procedures (page 51)
Won't eject ice with power available	Ice maker	Refer to ice maker test procedures (page 51)

Full Schematic

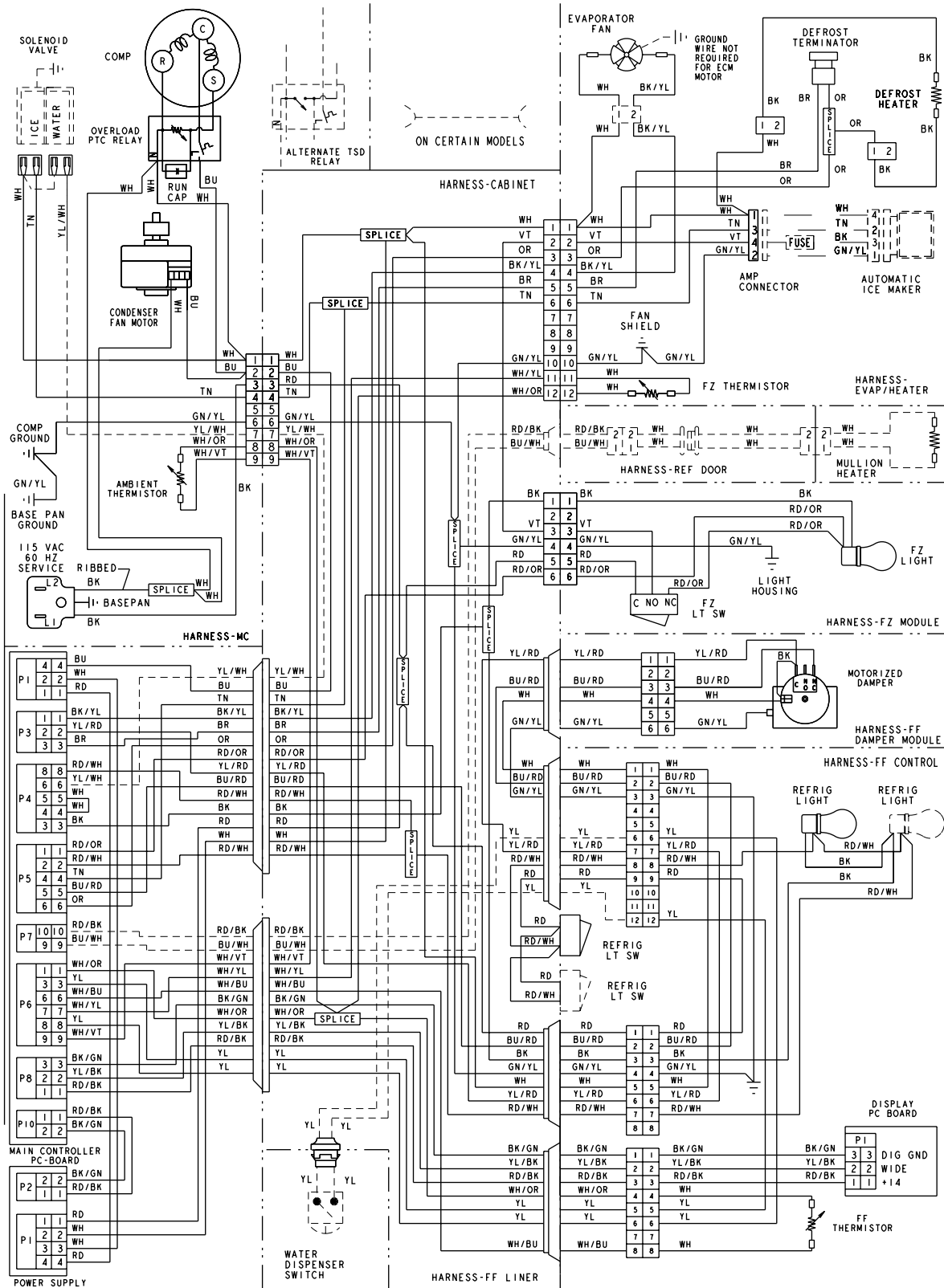

Wiring Diagram

