



Samsung 2 Door 2 Drawer Convertible Side by Side Training Manual

RM255BARB

RM255BASB

RM255BABB

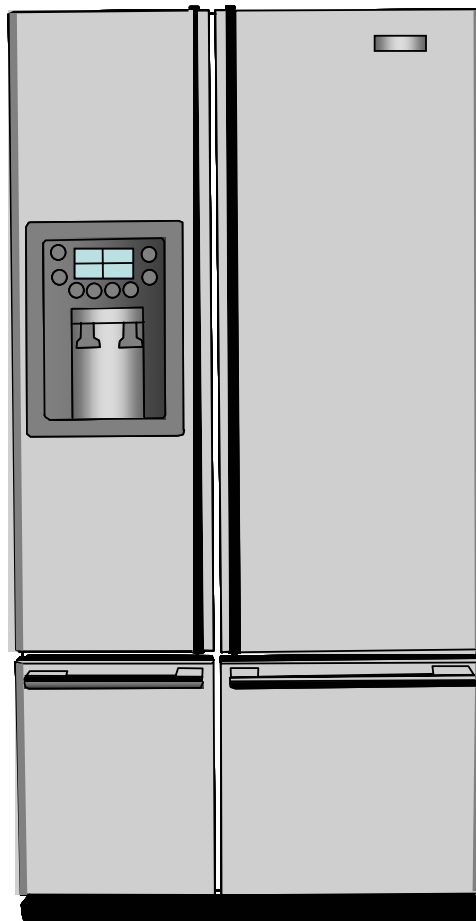



Authorized Training Center Campuses

Maytag maintains an affiliation with ten institutions in the US and Canada to offer technical training sessions focused on Maytag branded product. Maytag supplies the course content and product but each school operates as an independent agent and collects fees accordingly. All training sessions include classroom (30%) and lab time (70%) and cover both basic and advanced troubleshooting techniques. There are three standard one-week courses, Laundry, Refrigeration and Kitchen (Cooking and Dishwashers) and shorter 1, 2 and 3-day offerings. **Check the MAC website or LTS publications for class schedules.** Contact the schools for additional information and brochures

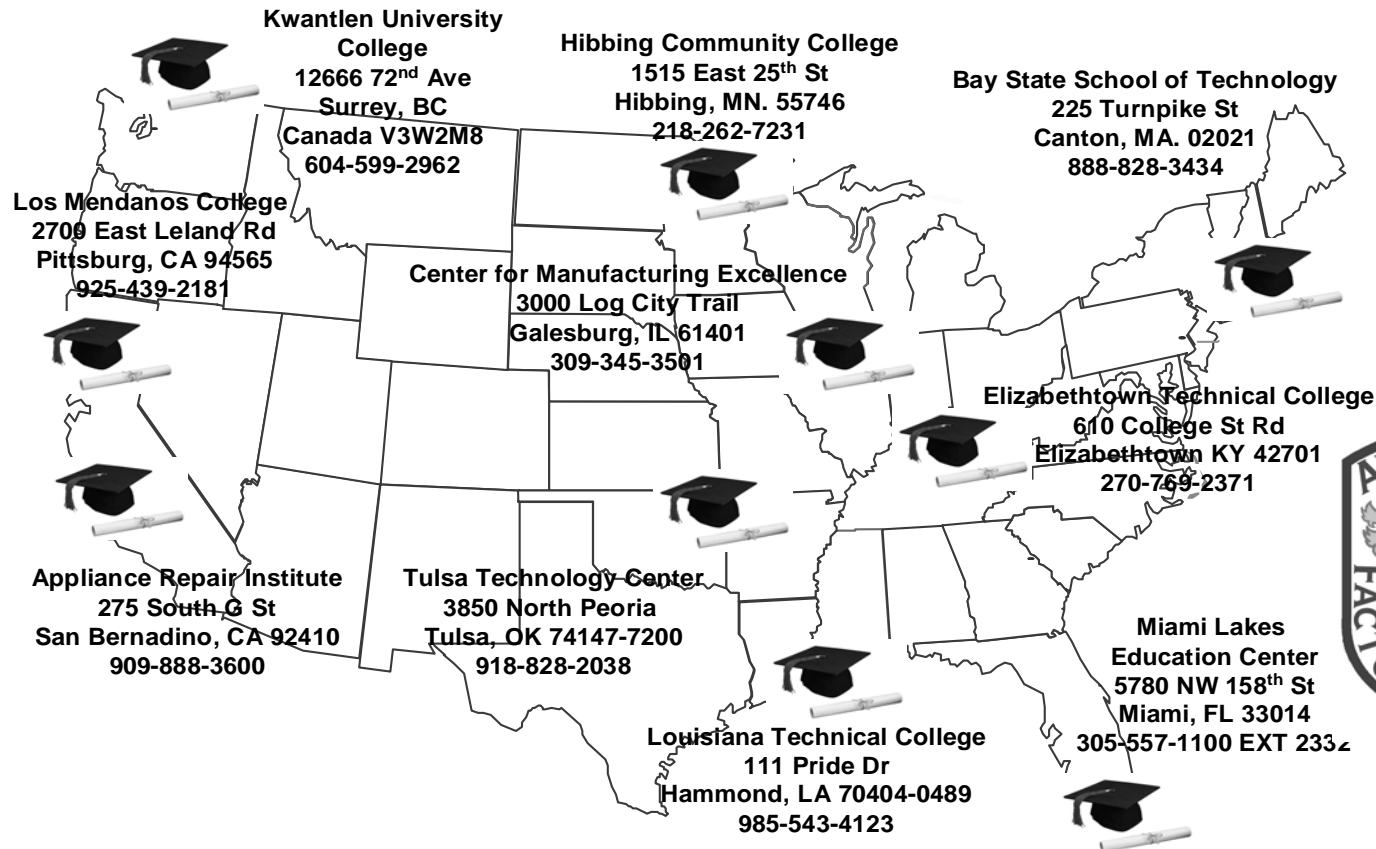



WARNING

IMPORTANT SAFETY NOTICE

This service guide is for service technicians with adequate backgrounds and electrical, electronic, and mechanical experience. Any attempt to repair a major appliance may result in personal injury and property damage. The manufacturer or dealer cannot be responsible for the interpretation of this information.

SAMSUNG ELECTRONICS AMERICA, INC.

Technical Service Guide

Copyright ©2005

All rights reserved. This service guide may not be reproduced in whole or in part in any form without written permission from the SAMSUNG ELECTRONICS Company.

CONTENTS

PRECAUTIONS	5
PRODUCT SPECIFICATIONS	8
OPERATING INSTRUCTIONS & INSTALLATION.....	13
DIASSEMBLY and REASSEMBLY	24
TROUBLESHOOTING.....	37
WIRING DIAGRAM.....	60
PCB DIAGRAM.....	73
CIRCUIT (SCHEMATIC) DIAGRAM.....	74
CURCUIT DESCRIPTIONS.....	75
REFERENCE INFORMATION.....	81

1. PRECAUTIONS(SAFETY WARNINGS)

- Unplug the refrigerator before making any repairs or any replacements.
 - ⇒ Avoid electric shock.
- Use rated components for the replacements.
 - ⇒ Check that they have the correct model number, rated voltage, rated current, operating temperature and so on.
- On repair, be sure that the wires such as harness are bundled tightly and are not exposed by water.
 - ⇒ Bundle wires tightly in order not to be detached by an the external force.
- Upon repair, completely remove dust, particles or other items from housing areas, harness parts, and connectors.
 - ⇒ Cleaning may prevent fire by tracking or short.
- Check if there is any trace of water infiltration on electrical parts.
 - ⇒ If there is kind of trace, change the related components or do the necessary action such as taping using the insulating tape.
- After repair, check the appearance of the assembled parts.
 - ⇒ They must look the same as they did before disassembly.
- Check the conditions surrounding the installed refrigerator.
 - ⇒ When the refrigerator is located at humid or wet place, or the installed state is unstable, change the location.
- If necessary instal a ground conductor.
 - ⇒ This appliance must be properly grounded, especially if there is a possibility of electrical leakage.
- Do not allow consumers to use one outlet for several plugs.
- Check whether the power cord has been placed under an other appliance and gotten, damaged, worn-out squeezed.
 - ⇒ Repair the defective power plug or outlet immediately.
 - ⇒ Make sure that the power cord is not placed under an other appliance or pinched.
- Do not allow consumers to keep bottles or the likes in the Freezer or to keep foods in unstable positions.
- Do not allow consumers to repair the appliance by themselves.
- Do not allow consumers to keep other chemicals except food.
 - ⇒ Medicines and other materials for research, this appliance will not maintain the precisely constant temperature for them.
 - ⇒ Volatile materials (Alcohol, Benzene, Ether, LP gas etc.) - possibility of explosion







PRECAUTIONS(SAFETY WARNINGS)

Read all instructions before repairing the product, and follow to the instructions in order to prevent danger or property damage.

CAUTION/WARNING SYMBOLS DISPLAYED

	Warning	Indicates that a danger of death or serious injury exists.
	Caution	Indicates that a risk of personal injury or material damage exists.

SYMBOLS

	means "Forbidden".
	means "do not disassemble".
	means "do not touch"
	means "Instructions that need to be followed"
	means "power cord should be unplugged from the consent"
	means "Ground to prevent Electric shock".



Warning & Caution

Pull the power plug out to exchange the interior lamp of the refrigerator.

- It may cause electric shock.



Unplug

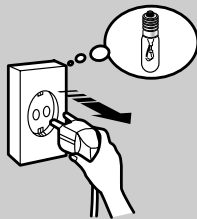

Use rated components for the replacement.

- Check for the correct model, rated voltage, rated current, operating temperature and so on.



Rated components



Upon repair, make sure that the wires such as harness are bundled tightly.

- Bundle wires tightly for them not to be detached by an external force and not to get wet.



Upon repair, remove completely dust or other items from the housing areas, harnesses, and check parts appearance.

- Cleaning may prevent the possible fire by tracking or short.

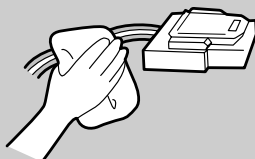

After repair, check the appearance of the assembled components.

- They must look the same as they did before disassembly.

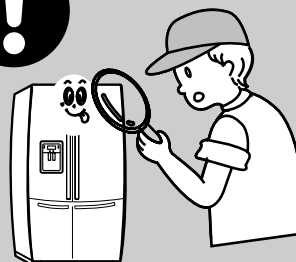

Check if there is any trace indicating water permeation.

- If there is that kind of trace, change the related components or do the necessary treatment such as taping using the insulating tape.

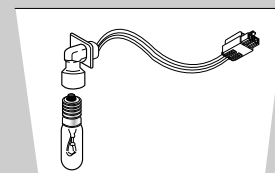

PRECAUTIONS(SAFETY WARNINGS)

* Please let users know following warnings & cautions in detail.



Warning & Caution

Do not allow users to put glass bottles or similar in the freezer.

● Freezing the contents may cause .



Forbidden

Do not allow users to store narrow and long bottles or foods in a small multi-purpose room.

● It may hurt you when the refrigerator door is opened and closed resulting in stuff falling down.



Forbidden



Do not allow users to store pharmaceutical products, scientific materials, etc., in the refrigerator.

● Products which require temperature control should not be stored in the refrigerator.



Forbidden



Do not allow users to insert the power plugs for many products at the same time.

● May cause abnormal generation of heat or fire.



Forbidden

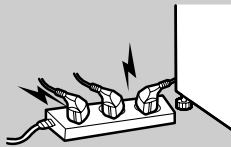

Do not allow users to disassemble, repair or alter.

● It may cause fire or abnormal operation leading to injury.



Do not disassemble

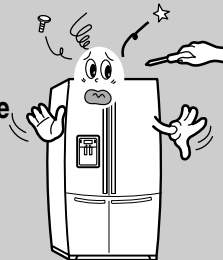

Do not allow users to bend the power cord with excessive force or do not allow the power cord to get pinched by a heavy item.

● May cause fire.

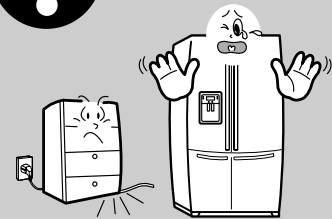

Do not allow users to store articles on top of the product.

● Opening or closing the door may cause things to fall down, which may cause injury.



Forbidden

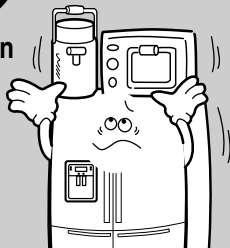

Do not allow users to install the refrigerator in a wet place or a place where water splashes.

● Deterioration of the insulation of electric parts may cause electric shock or fire.

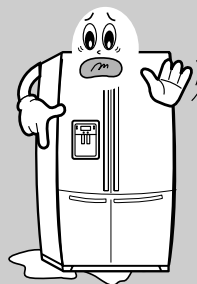

Ensure grounding.

● If grounding is not done, it will cause breakdown and electric shock.



Ground

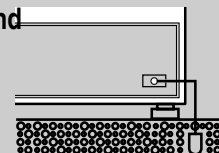

2. PRODUCT SPECIFICATIONS

2-1) Introduction of main functions.....	8
2-2) Model Specifications.....	9
2-4) Electric Parts Specifications.....	10
2-6) Optional Material Specifications.....	12

PRODUCT SPECIFICATIONS

2-1) Introduction of main function

- **THE SAMSUNG side by side refrigerator has the following characteristics:**



TDM System(Time-Divided-Multi-evaporator system)

- Each compartment has one evaporator, so this refrigerator has 4 evaporators. Also, microprocessors and a refrigerant control valve control the refrigeration cycle of the 4 evaporators to achieve high efficiency and high humidity in the fridge. Food odor from one compartment of the refrigerator does not affect food in the other compartments because of separate cooler and air flow systems.

Multi-Flow System

- Cool air circulates through multiple vents on every shelf level. This provides even distribution of cooling inside cabinets to keep your food fresh longer.

Door Alarm

- A beeper reminds you that the door is open.

Xtra Fresh™

- Optimized humidity control keeps vegetables & fruits fresh.

Arctic Select Zone™ Drawer

- The Arctic Select Zone Drawer is convertible from a freezer to a refrigerator by the TDM system. The user can select Power Freeze, Freezer, Soft Freeze, or Cool according to the type of food.

Fresh Select Zone™ Drawer

- The user can select Soft Freeze, Chill, Cool or Fresh according to the type of food. Especially in Cool and Fresh, the drawer humidity is high by the TDM system.



NOTE

This operation instruction covers various models.

The characteristics of your appliance may differ slightly from those described in this manual.

PRODUCT SPECIFICATIONS

2-2) Model Specification

Item		Specification
Model		RM25*****
		Dispenser without beverage station
Net Capacity	Total	24.8 ft ³
	Fridge	11.6 ft ³
	Freezer	7.0 ft ³
	CR Fresh Select Zone	3.8 ft ³
	CF Arctic Select Zone	2.4 ft ³
Net dimension(W×D×H)		$38\frac{7}{8} \times 35\frac{1}{4} \times 70$
Rated Voltage and Frequency		115V/60Hz
Motor Rated Power Consumption		183W
Electric Heater Rated Power Consumption		470W
Refrigerator Type		Indirect Cooling Method Refrigerator
Refrigerant		R-134a
Refrigerant Input Amount		235g(8.29oz)
Product Weight		before packing : 353lbs after packing : 386lbs

PRODUCT SPECIFICATIONS

2-4) Electric Parts Specification



Item			Specification		
Model			RM25*****		
Freezer Components	Compressor	Model	MK183C-L2U		
		Starting type	R.S.C.R		
		Oil Charge	FREOL α - 10 (ESTER)		
	Evaporator	Freezer	SPLIT FIN TYPE		
		Fridge	SPLIT FIN TYPE		
		CR Fresh Select Zone	SPLIT FIN TYPE		
		CF Arctic Select Zone	SPLIT FIN TYPE		
	Condenser		Forced and natural convection type		
	Dryer		Molecular sieve XH-9		
	Capillary tube		F capi 0.85 × 3300mm(0.033" × 129.9") R capi 0.85 × 3000mm(0.033" × 118.1") C capi 3.56 × 650mm(0.140" × 25.6")		
Refrigerant		R-134a			
Room Temperature Sensor Components	Freezer	Model	Temperature Selection	ON(°F)	OFF(°F)
		THERMISTOR (F-SENSOR) 502AT	-14°F	-12°F	-16°F
			-2°F	0°F	-4°F
			6°F	8°F	4°F
	Refrigerator	Model	Temperature Selection	ON(°F)	OFF(°F)
		THERMISTOR (R-SENSOR) 502AT	34°F	36°F	32°F
			38°F	40°F	36°F
			46°F	48°F	44°F
	Defrost Cycle	First Defrost Cycle (Concurrent defrost of F and R)		4 hr ± 10 min	
		Defrost Cycle(FRE)		8 ~ 16hr (varies according to conditions of use)	
Defrost Cycle(REF)		8 ~ 16 hr (varies according to conditions of use)			
Pause time		10 ± 1 min			
Defrost Related Components	Defrost Cycle	R Defrost-Sensor	Model	THERMISTOR (502AT)	
			SPEC	5.0k Ω at 77°F	
		F Defrost-Sensor	Model	THERMISTOR (502AT)	
			SPEC	5.0k Ω at 77°F	
		CF Defrost-Sensor	Model	THERMISTOR (502AT)	
			SPEC	5.0k Ω at 77°F	
	CR Defrost-Sensor	Model	THERMISTOR (502AT)		
		SPEC	5.0k Ω at 77°F		
Bimetal	Operating temperature	60°C OFF / 40°C ON(140°F OFF / 104°F ON)			

PRODUCT SPECIFICATIONS

Items			Specifications		
Model			Dispenser	Home Bar	
Electric Components	Defrost-Heater(FRE)	Conducting F Defrosting	200W		
	Defrost-Heater(REF)	Conducting R Defrosting	80 W		
	Defrost-Heater(CF)	Conducting CF Defrosting	100 W		
	Defrost-Heater(CR)	Conducting CR Defrosting	80 W		
	DRAIN PIPE(FRE)	Conducting F Defrosting	5 W		
	DRAIN PIPE(REF)	Conducting R Defrosting	5 W		
	DISPENSER Heater	Interlock with F-FAN	7W		
	WATER PIPE Heater	-	5W		
	WATER TANK Heater	-	3W		
	Bimetal			60°C OFF / 40°C ON (140°F OFF / 104°F ON)	
	Condenser for COMP (Package type)	Running	250VAC-12μF		
		Starting	-		
	Starting-Relay	Model	J531Q32E4R7M182		
		Operation	4.7 Ω ± 20%		
	Over-load Relay	Model	4TM445PHBYY-53		
		Temp. ON	257 ± 41°F		
		Temp. OFF	156.2 ± 48.2°F		
	Rated Voltage			115V/60Hz	
	MOTOR-BLDC(FRE)			DREP3020LA	
	MOTOR-BLDC(REF)			DREP3020LA	
MOTOR-BLDC (Circuit)			DREP3030LA		
Lamp(FRE)			AC120V/40W × 2		
Lamp(REF)			AC120V/40W × 3		
Lamp(CF)			AC130V/30W × 1		
Lamp(CR)			AC130V/30W × 1		
Door Switch			AC250V 0.5A × 4		
Power cord			AC125V 15A		
Ground Screw			BSBN (BRASS SCREW)		

PRODUCT SPECIFICATIONS

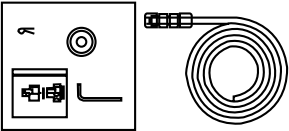
2-6) Optional Material Specifications

Photograph	Part Name	Part Code	Remarks
	FILTER WATER-ASSY	DA29-00012A	
	ASSY-INSTALL FILTER	DA97-01469D	
	INCANDENT LAMP	4713-001194	Refrigerator : 3pcs Freezer : 2pcs 120V, 40W
	INCANDENT LAMP	4713-001172	CF : 1pcs CR : 1pcs 130V, 30W

3. OPERATING INSTRUCTIONS & INSTALLATION

3-1) Digital Panel.....	14
3-2) Temperature Control Operation	14
3-3) Power Freeze and Vacation Operation.....	15
3-4) Lock Function	16
3-5) Functions Where the Ice Dispenser and Water Dispenser Have Been Attached (External Type).....	16
3-6) Light Operation	17
3-7) Machine Room F-Fan Motor Delay Function.....	17
3-8) Ice Maker Function	18
3-9) Defrosting Function.....	22
3-10) Arctic Select Zone Function.....	23
3-11) Select Fresh Zone Function.....	23
3-13) Alarm Function	26
3-14) Communication Error Display Function.....	26
3-15) Self-Diagnostics Function	27
3-16) Load Condition Display Function.....	31
3-17) Operation Condition Recovery Function in Case of Power Outage	32
3-18) Option Setting Function	32

OPERATING INSTRUCTIONS & INSTALLATION

3-1) Digital Panel

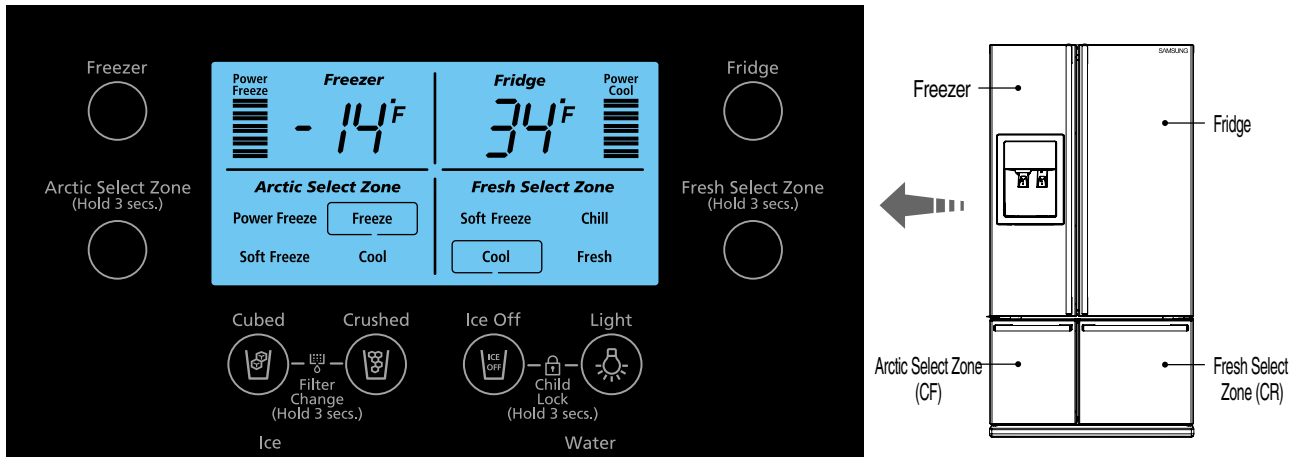

3-2) Temperature Control Operation

1) Temperature Selection for the Freezer Compartment

1-1) There are automatic temperature settings of -2 for the freezer compartment and 38 for the fridge compartment when initially applying electric power after installing refrigerator.

The numbers on the display represent the inside temperature of the refrigerator product. when the set temperature and the displayed temperature are different from each other, it will be automatically adjusted to the set temperature. (actual display range of temperature : 15°F ~ 80°F for the fridge compartment and -25°F ~ 80°F for the freezer compartment)

when the freezer temperature is set, it will display the set temperature for the first 5 seconds. and then, it will display its current temperature.

1-2) The temperature of the freezer compartment may be set to 6°F ~ -14°F by operating the temperature selection button for the freezer compartment.

→ -2°F → -4°F ... → -14°F → Power Freeze → 6°F → 8°F → -2°F ← Selected in rotating sequence

2) Temperature Selection for the Refrigerator Compartment

2-1) The temperature of the refrigerator compartment may be set to 46°F ~ 34°F by operation the temperature selection button for the refrigerator compartment.

(Example: → 38°F → 36°F → 34°F → Power Cool → 46°F → 44°F ... → 38°F)

2-2) Temperature that has been set for the freezer compartment/ the refrigerator compartment may vary by a little difference depending on ambient temperature and user's food storage style. (Take heed because if food would contact too closely with refrigerator temperature sensor position, then under cooling [overcooling] may arise as

※ **Note**) If temperature in the freezer compartment is lower than 41°F (when electric power is supplied again after momentary electricity interruption / when electric power had been cut off for a short time by unstable electric supply because of electricity supply line problem so as to be connected again, then the refrigerator judges it as momentary power interruption. So the refrigerator reads again to use them after saving the temperatures and the functions that had been set in EEPROM

OPERATING INSTRUCTIONS & INSTALLATION

3-3) Power Freeze and Power cool Operation

1) Power Freeze Operation

- 1-1) Select 'Power Freeze' by pressing the freezer compartment button. If 'Power Freeze' function is selected, icon display immediately changes to show the newly selected condition but actual function starts to operate after 10 seconds. Where if 'Power Freeze' function is terminated by reselecting the ordinary freezer compartment button during performance of 'Power Freeze' selection, then icon turns off simultaneously with button input as well as 'Power Freeze' function is instantly terminated.
- 1-2) If power freeze is selected, the COMP and F-FAN operate continuously for 2 hours and 30 minutes.
- 1-3) The refrigerator compartment operates per the current set condition even during power freeze operation.
- 1-4) When power freeze is terminated, ICON signifying the power freeze turns off automatically and operation there is by temperature ordinarily set for the freezer compartment. This temperature ordinarily set for the freezer compartment when power freezing operation has been terminated is automatically set at -2°F .
- 1-5) Even if the condition to start defrosting has been met while the power freezing is in progress, defrosting is delayed until termination of power freezing. If power freezing is selected during defrosting, the ICON turns on readily but the COMP and F-FAN turn on only after defrosting is terminated.

2) Power cool Operation

- 2-1) If power cool is selected by pressing the fridge compartment button, icon display is lighted and the operation is executed. If power cool is canceled by using the fridge compartment button, the icon is extinguished simultaneously and the well as power cool operation is terminated instantly.
- 2-2) The temperature setting of the freezer compartment is feasible even under the condition where power freezing has been selected.
- 2-3) If power cool is selected, COMP and R-FAN operate continuously until the fridge compartment temperature drops down to 24.8°F . When the function automatically terminates if the continuous operation time reaches 2 hours 30 minutes.
- 2-4) If the fridge compartment temperature reached 24.8°F , power cool function terminates after operation for 1 hour at 33.8°F by in inside function irrespective of current setting.
- 2-5) Icon of power cool is automatically extinguished at time point when power cool function is terminated (namely either after elapse of 2 hours 30 minutes or after termination of operation for 1 hour at 33.8°F from time point of arriving at 24.8°F) and afterwards operation is according to temperature ordinarily set for the fridge compartment. (The fridge compartment is converted to the setting of 37.4°F when power cool function is automatically terminated.)
- 2-6) Control may vary according to various variables (temperature setting etc.) besides the above conditions.

3) If Power Freezing and Power cool Have Been Selected Simultaneously

- 3-1) The respective functions apply simultaneously. Namely the power freezing operates the COMP and F-FAN continuously without restriction to the power cool function, while this power cool function operates the COMP and R-FAN continuously until the Fridge Compartment temperature drops down to 24.8°F .

OPERATING INSTRUCTIONS & INSTALLATION

4) At Initial Power On

- 4-1) At initial power on of fridge product when temperature in the freezer compartment is not lower than 14°F and temperature in the fridge compartment is not lower than 50°F, if power freezing and power cool functions are selected, operation will be different from the above functions.
- 4-2) In this case, R-FAN turns off for a little while if power freezing is selected whereas F-FAN turns off for a little while if power cool is selected. This operation works only once at time of initial power on.
- 4-3) This function is to powerfully cool down only the ROOM preferably wanted by customer when using fridge product for first time while temperature in product would be rather high.

3-4) Lock Function

- The lock function is set and canceled by the ICE-OFF and the LIGHT BUTTONS.
 - Lock function is set if ICE-OFF BUTTON and LIGHT BUTTON are simultaneously depressed for 3 seconds under lock cancellation status.
 - If the lock function has been set, then the ice selection function, functions related to the dispenser, and all other functions are to be held because temperature control / power functions / Arctic Select Zone function / Fresh Select Zone function / ice selection function etc. maintain their current setting conditions. (when the lock LED is on.) This function has been developed to prevent random operation by children (infants).
 - If to cancel lock function under condition where lock function has been selected, then lock function may be relieved if ICE-BUTTON and LIGHT BUTTON are simultaneously depressed for 3 seconds so as to be able to operate on front panel.
- If the lock function has been canceled, the lock LED turns off and you may perform key selection. We recommend you to use lock function for user's necessity, and to be well acquainted with it in advance because this function may bring about customer's NON-SENSE CALL.

3-5) Functions in Case Where Ice Dispenser and Water Dispenser Have Been Attached (External Type)

- This function applies only for model where ice maker and ice/water dispenser have been attached.

1) CUBE / CRUSHED / ICE OFF Selection Function

- 1-1) This function is to operate in CUBE/ CRUSHED / (ICE OFF function according to selection upon DISPLAY by user, which selection is made use by each corresponding button.
- 1-2) CRUSHED is automatically selected at initial POWER ON of the refrigerator product.
- 1-3) Water is extracted by operating the WATER SOLENOID VALVE under the condition of WATER LEVER ON.
- 1-4) Operate by using AUGERMOTOR and cubic ice solenoid the ice that has been made in ice tray when drawing out ice after selecting the CUBE.
- 1-5) Operate by using only AUGER MOTOR the ice that has been made in ice tray when drawing out ice after selecting the CRUSHED .
- 1-6) ICE-MAKER stops operation if function of ICE OFF has been selected. After if cubic / crushed are selected, function of ice off is automatically halted so as to facilitate again execution of ice maker function that was in use before ice off.

OPERATING INSTRUCTIONS & INSTALLATION

=> ICE-MAKER stops operation if function of ICE OFF has been selected. After if cubic / crushed are selected, then water is supplied. If cubic / crushed are selected, now you can be promptly provided with ice only that was already formed before selecting ice off.

1-7) When drawing out ice, this is extracted after DISPENSER SWITCH is depressed and ICE COVER is completely opened.

1-8) ICE COVER is shut after 5 seconds from time point when DISPENSER SWITCH turned off after drawing out ice.

1-9) If DISPENSER SWITCH turned ON or WATER SWITCH turned ON, DISPENSER LAMP is lighted but turns off after 5 seconds from time point when DISPENSER SWITCH and WATER SWITCH would have turned OFF.

※ **Caution** : because if ice cover is coercively closed then it may be damaged, please draw out ice once again if ice cover would not be closed, so that the cover operate rationally.

※ **Note**) When drawing out ice after selecting the ice stop, only the ice remaining in ice tray may be drawn out. And even when ice stop has been selected, cubic / crushed may be used restricted to the remaining ice.

2) Water Dispenser Function

2-1) As this function is type of direct connection to water, it works so that water is extracted by opening of water solenoid valve installed at right side of machine compartment if water lever is depressed. If abnormality occurred in water dispenser function, repair it by checking solenoid itself, connection tube, water supply status etc.

3-6) Light Operation

6-1) This function is selected or canceled by light selection button.

6-2) If the light button is selected under light cancellation status, the LIGHT LED and the DISPENSER LIGHT turn on.

6-3) If the WATER SWITCH or the DISPENSER SWITCH is turned on, under the condition of light cancellation status, the DISPENSER LIGHT turns on.

6-4) Under the condition of light function selection, the LIGHT LED and the DISPENSER LIGHT are always turned on regardless of WATER SWITCH and DISPENSER SWITCH operation conditions.

3-7) Machine Room F-Fan Motor Delay Function

- The temperature in this refrigerator is automatically controlled by program depending on ambient temperature. Among the operative functions depending on ambient temperature, the compressor cooling fan (machine room fan) is controlled as shown in the table below. Accordingly, in case that cooling fan may revolve with delay or may not revolve at all according to conditions when operating the compressor, please be acquainted with details and refer to them during service.

	Temperature Range	Load Operation Condition
Machine Room Fan Delay Function	Exterior temperature 46.4°F	Machine room fan is immediately turned on as the compressor is ON.
	Exterior temperature 44.6°F	Machine room fan is OFF regardless of the compressor.

OPERATING INSTRUCTIONS & INSTALLATION

3-8) ICE-MAKER Function (applies only for model with dispenser function)

- This ICE-MAKER function is option specification so as to be drawn to the function explanation for relevant model.
- ICE-MAKER is model attached with unit equipment where is furnished function of automatic ice making so that ice may be made in container inside the freezer compartment and may be drawn out by using ice dispenser under storage status ==> The equipment.

1) Initial Operation

This is operation at initial “power on” or at that after “power off” due to electricity interruption which operation is to restore to horizontality by revolving ice extraction motor.

- 1-1) At first no operation is performed for 2 seconds after initial power on or after power returns after a momentary power outage. But after that, an initial horizontality operation of the ice extraction is performed.
- 2-1) Because the condition of the ice maker is unknown, first the ice extraction motor is turned in the reverse direction to let it come to its most horizontal position possible. The judgment of horizontal position is done by the ice extraction S/W. If this S/W is on for more than 2 seconds during the reverse rotation of the ice extraction motor, then it is judged that the transition to the most horizontal position possible has been made and the ice extraction motor is stopped (1). It waits a second in this condition.
- 3-1) Because condition 2-1) is an upset twisted condition caused by the reverse direction rotation of 2 seconds after sensing the horizontal position, the motor revolves in the forward direction for 200 ms after ice tray S/W off (2) and then It waits 1 second.
- 4-1) Finally to achieve horizontality, the ice tray motor turns again in the reverse direction but it will stop immediately if the ice tray S/W comes on (3), which condition may be interpreted as the horizontal
- 5-1) The standby condition is maintained for 2 hours regardless of any conditions after Ice-Tray horizontality operation. Therefore, under the initial power on condition, there is no movement for 2 hours except for the ice tray horizontality operation.
- 6-1) Ice is made if the ice making temperature has been reached according to the ice tray temperature check after a 2 hours wait period (initial ice extraction mode).

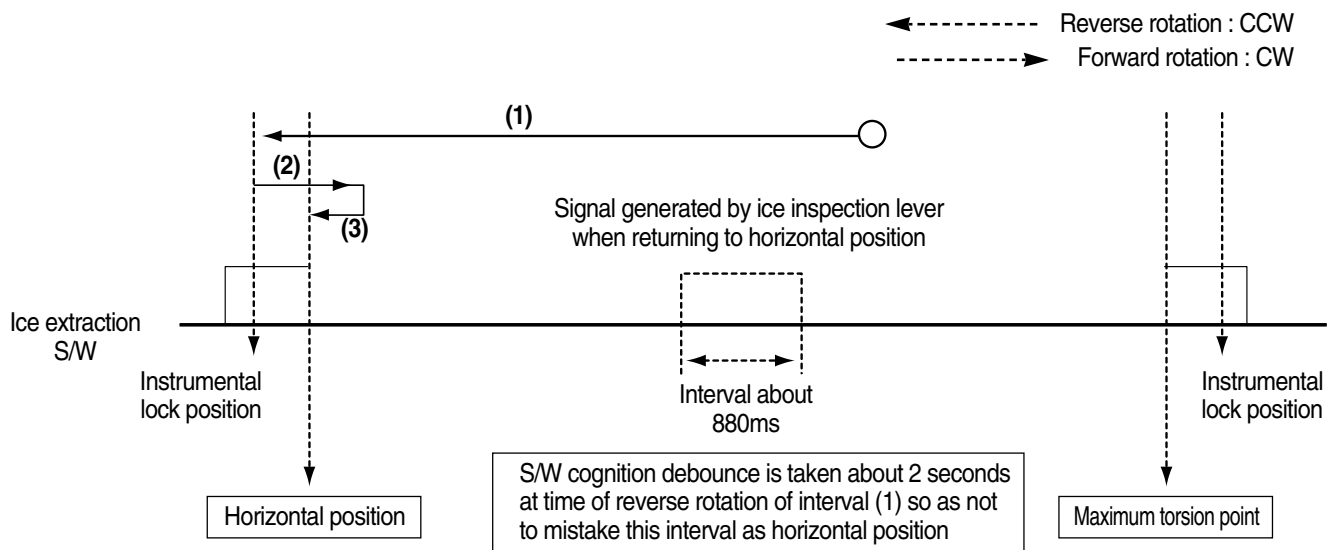

Figure- Horizontal movement operation at initial power on of the product (refers to ice extraction S/W)

OPERATING INSTRUCTIONS & INSTALLATION

2) Water Supply Function

2-1) After finishing the ice extraction operation (initial ice extraction operation, normal ice extraction operation and ice extraction operation of test function) and performing the ice receptacle horizontality operation, if it is judged to have attained horizontality, then there is executed operation of water solenoid located in refrigerator machine compartment for time check function so as to supply water into the ice maker receptacle.

Model	Water Supply Time	Remark
Model furnished with ice-maker function option	Cf. OPTION function & FLOW_SENSOR function	It may be altered by OPTION function and water supply rate may vary depending on water pressure since it is connected directly to the water source.

3) Ice-Making Function

- Here is referred to period until it is opined that water in ICE -TRAY(ice maker vessel) has completely become ice after finishing the water supply operation, which period is judged by sensed temperature (which is alterable option) of ice maker sensor.

3-1) The ice maker sensor temperature is automatically checked after 58 minutes have elapsed (65 minutes in case of overload) from the time when water was supplied into the ice maker receptacle.

3-2) If the ice maker sensor maintains below 1.4°F for 5 minutes, then it is judged that the ice making cycle has been completed.

3-3) In case of initial electric power application to the product or in case of recovery from a power outage, the ice extraction is operated after waiting 2 hours, not detaching the ice after checking the the ice maker sensor even though the temperature may be checked to have reached below 1.4°F

※ **Note)** While it is not full of ice is not fully frozen or when ICE OFF has not been selected, it operates internally at -13.0°F until it becomes full of ice (until the ice tray is of ice). As soon as full ice is achieved, the freezer compartment temperature is automatically controlled at the temperature set by the customer.

4) Ice Extraction Function

- The ice extraction function is to separate the ice in the ice extraction (ice maker vessel) after completing the ice making process. This function is achieved by operating in accordance with to the following steps. These operations are classified into full ice case and non-full ice case according to the ice extraction S/W condition variation:

Full ice case : step 1 → step 2 → step 3 → step 4 → step 5 → step 6

Non-full ice case : step 1 → step 2 → step 6

4-1) **Step 1:** this is stage to check firstly the ice making temperature in order to perform ice extraction where check is performed both if the current ice making temperature is below 1.4°F and if 90 minutes (55minutes in case of power freezing) have elapsed after water supply.

- If the F compartment enters defrosting while waiting for ice tray, counting is restarted from 0 after defrosting is completed so that the check is performed if the ice extraction waiting (58 minutes) has elapsed after defrosting the F compartment. The ice maker temperature sensor enters step 2 if 5 minutes pass after going below 1.4°F .

OPERATING INSTRUCTIONS & INSTALLATION

- 4-2) **Step 2** : operation is to overturn tray in order to separate the ice in the ice tray where tray is overturned by direction rotation of ice extraction motor.
- In case the storage container is full ice: if the ice extraction S/W is ON again before 3.6 seconds elapse from the time the extraction S/W condition changed to "on → off" has occurred after starting rotation of the ice extraction motor, then this means that the storage tray is full of ice so that direction rotation of the motor is interrupted so as to start reverse direction rotation (horizontal movement) after waiting a second. Step 6 is executed.
 - In case the storage is not full ice: if the ice extraction S/W is not ON again after 3.6 seconds from the time when the ice extraction S/W condition changed to "on → off" has occurred after starting rotation of the ice extraction motor, then this is judged to mean that it is not full of ice, in which case normal ice extraction movement is performed and step 3 is executed.
- 4-3) **Step 3** : if the ice extraction S/W is not ON again after 3.6 seconds from the time when the ice extraction S/W condition changed to on "on → off" has occurred after starting rotation of the ice extraction motor, then this is judged to mean that it is for normal ice extraction operation. If F compartment door is opened during ice extraction operation thereafter, operation stops for a while and restarts after Door Close.
- 4-4) **Step 4** : motor rotation stops if the ice extraction S/W turns on after 3.6 seconds have elapsed from the start of the rotation. This point is the maximum torsion point and waits a second under this condition.
- 4-5) **Step 5** : It is a step that ice extraction restores horizontally accomplished by reverse rotation of ice extraction motor. So after step 4, the ice extraction motor turns in the reverse direction when the ice extraction S/W always senses the full ice lever signal regardless of the ice existence of the ice storage container so as to be called the "Return Pulse".
- 4-6) **Step 6** : if the ice extraction S/W turns ON after the "Return Pulse, the reverse rotation of the ice extraction horizontally motor stops and the ice extraction is judged to be in the horizontal position. If now it has been restored horizontally after sensing full ice, water is not supplied but ice extraction is retried consecutively in 1 hour intervals until full ice cancellation. So thereafter, water is supplied if normal ice extraction has been performed.
- 4-7) Figure shows operation specification of ice extraction (in case of non full ice / full ice).
(bold numerals indicate relevant ice tray steps.)

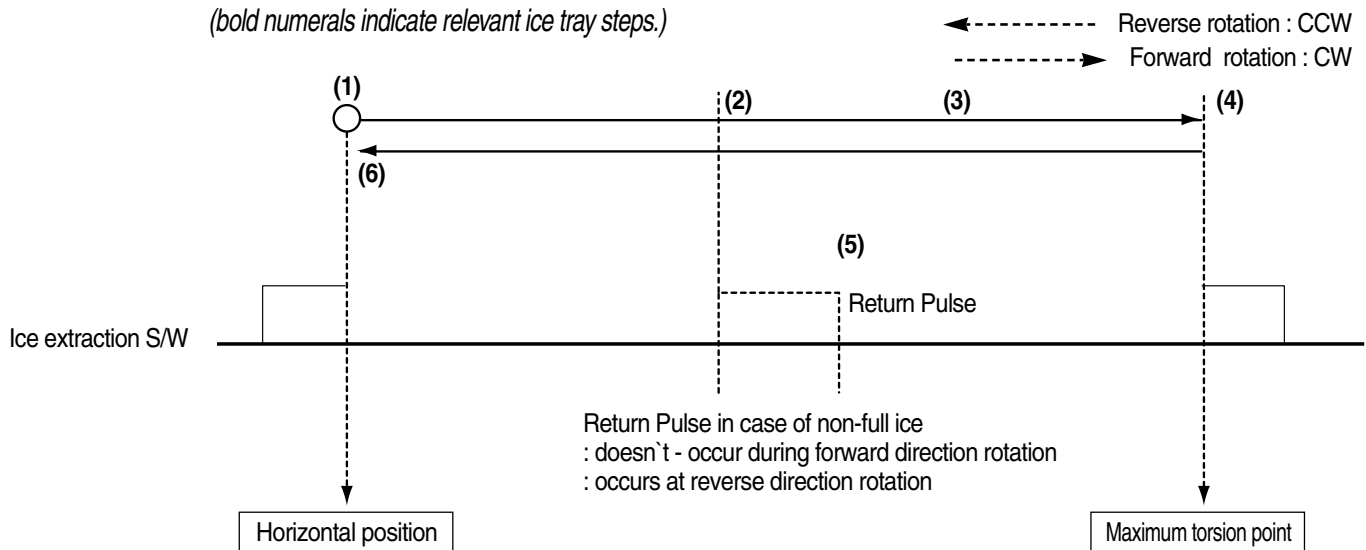

Figure - Normal ice extraction and horizontality operation (in reference to the ice extraction S/W)

OPERATING INSTRUCTIONS & INSTALLATION

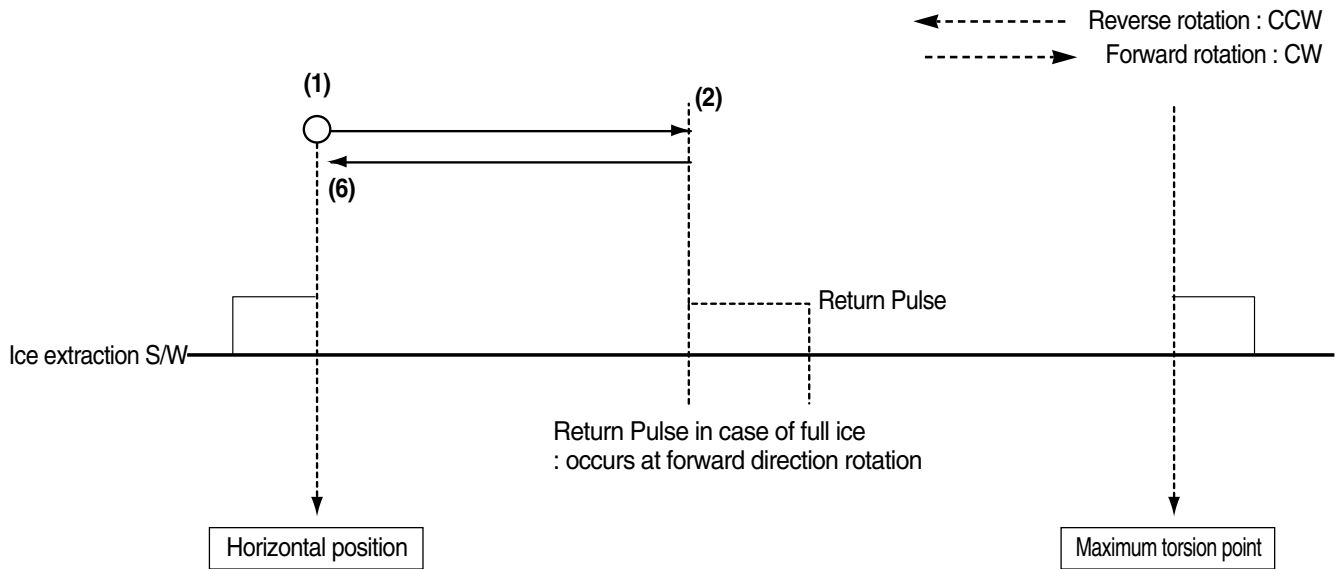

Figure - ice extraction and horizontality operation in case of full ice (in reference to the ice extraction S/W)

5) Test Function

- This function is useful when there is a need for forced operation for testing purposes, A/S, cleaning etc. This function is executed when the test S/W attached to the automatic ice maker itself is pressed for more than 1.5 seconds.

5-1) The test function by pressing test button cannot be engaged during ice extraction, horizontality noise or water supply operation but can operate when in the horizontal condition. Also, the test function cannot operate when ice is full. The operation is only feasible when full ice has been relieved..

5-2) If the test button is pressed for more than 1.5 seconds in horizontal status, the ice extraction is operated directly regardless of the ice making condition of the ice maker container. Beware that water pours out if test function operates with unfrozen water. 1 cycle of water supply is executed at the horizontal noise operation after the ice transfer operation. Therefore it is feasible to check ice extraction operation, horizontality operation and water supply problems by using the test button. When the test function is normally executed, the buzzer sounds "ding dong" and the water supply function is executed. If buzzer does not sound "ding-dong", it signifies abnormality so check and repair is needed.

5-3) If the water supply has finished, it then goes through a normal cycle of ice making → ice extraction → horizontality operation → water supply again.

6) ICE OFF Function

- Ice making can be stopped by pressing the ice selection button to select ICE OFF when either ice is not wanted or its use is not needed.

6-1) ICE OFF is selected if the ice selection button is pressed on the DISPLAY and ICE OFF is canceled if the button is pressed again.

6-2) When the electric power turns on, the refrigerator operates automatically in the ice making mode where fragment ice is automatically selected and the lamp is lit.

6-3) If you want to, ICE OFF is selected by using the ice selection button, then the ice maker does not operate and it maintains the stop condition.

OPERATING INSTRUCTIONS & INSTALLATION

- 6-4) Display lamp is directly extinguished right at the stop selection, but it maintains stop condition after the completion of final water supply if water supply, ice extraction or horizontality noise is under progress.
- 7) At test operation by test key, ice tray operates regardless of F compartment door opening.
- This function basically stops the operation if the F compartment door is opened, so that noise may be minimized.
- 7-1) The ice extraction function promptly stops the operation when the F compartment door is opened while the ice extraction is working where as normal operation is restored when the door is closed.
- 7-2) During water supply, normal function is performed regardless of the F compartment door opening.
- 7-3) When checking by opening the F compartment door, if the extraction has been tilted or is not horizontal, it is a stop condition during ice extraction or horizontality operation because of the F compartment door opening. Then check again after more than 30 seconds elapse from the time when the F compartment door closed to ensure a horizontal condition after the water supply operation, if the extraction has not restored its horizontal status, it is ok to judge it to be a trouble/ failure. When operation stops by the F compartment door opening during (ice extraction) operation, because it has been during actual operation, even the test function does not work, but it may work after water supply completion.
- => When checking by opening the F compartment door during ice extraction or horizontality operation, if the tray is tilted or distorted, it is a stop condition because of F compartment door opening. Then check again after more than 30 seconds have elapsed from time when the F compartment door closed, if the tray has not restored its horizontal status, it is ok to judge it to be a trouble/ failure. When operation stops by the F compartment door opening during ice extraction operation, because it has been during actual operation, even the test function does not work.
- 7-4) During test operation by using the test key, the ice extraction operates regardless of F compartment door opening.

3-9) Defrosting Function

- 1) Defrosting of the F compartment, Arctic Select Zone, R compartment and the Fresh Select Zone is determined by the cumulated time period of COMP. ON.
- 2) In case of initial POWER ON of the refrigerator product, defrosting of the Freezer Compartment and Arctic Zone is executed when 4 hrs. of cumulated COMP. ON time period have elapsed.
- 3) The defrosting period is fixed to 8 hours.
- 4) Judgment of the defrosting period is determined by the exterior temperature, the number of times the F, R DOOR OPEN, and the duration of the F, R DOOR OPEN period.
- 5) The defrosting point temperature HEATER ON (start temperature) is determined by the temperature reading of the R defrosting sensor, the F defrosting sensor, the Arctic Zone defrosting sensor and the Fresh Zone defrosting sensor as follows:

	R Compartment	F Compartment	Arctic Zone		Fresh Zone	Remarks
			Other Setting	When Setting to COOL		
Defrosting Recovery Temperature	53.6°F	53.6°F	53.6°F	62.6°F	62.6°F	

※ **Note)** The defrosting recovery temperature may be changed at any time, for performance improvement etc..

OPERATING INSTRUCTIONS & INSTALLATION

3-10) Arctic Select Zone Function

- 1) Arctic Select Zone is set to Freeze at initial POWER ON.
- 2) The function is set and changed as follows by pressing the Arctic Select Zone button.

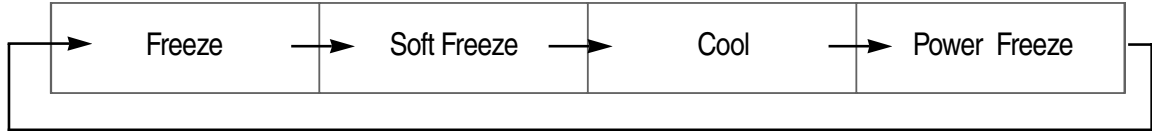

- 3) If pressing the button for initial setting of Arctic Select Zone for 3 seconds, buzzer sound is heard and simultaneously Arctic and Fresh Select Zones are converted to a function setting mode.
- 4) If the Arctic Select setting button is pressed again, in the function setting mode, the function setting is sequentially changed as in item 2 above).
- 5) The function setting mode is canceled when 10 seconds have elapsed after pressing the button and entering the Arctic function setting mode.
- 6) The Arctic Select Zone function operates as follows.

FUNCTION	OPERATION SPECIFICATION	REMARKS
Freeze	Interlocked with the set temp. (5°F ~ -13°F) of the freezer compartment	
Soft Freeze	Arctic Select Zone, 23°F operation	
Cool	Arctic Select Zone, 37.4°F operation	
Power Freeze	- If this function is selected, it operates continuously for 2 hours and 30 minutes. - If this function finishes automatically, it is automatically converted to Freeze.	

3-11) Fresh Select Zone Function

- 1) At initial POWER ON of the refrigerator, the Fresh select Zone is set to Cool.
- 2) This function is set and changed as follows by pressing the Select Fresh Zone button.

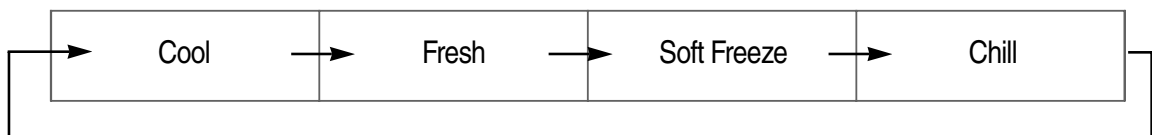

- 3) If initially the button to set the Fresh select Zone is pressed for 3 seconds, the buzzer sounds, and at same time, the mode is converted to the Arctic and Fresh Select Zones function setting mode.
- 4) If the Fresh Select setting button is pressed again, in the setting mode, function setting is sequentially changed as in item 2 above).
- 5) The function setting mode is canceled after 10 seconds have elapsed from pressing the button to Fresh Select Zone.
- 6) Fresh Select Zone function operates as follows.

OPERATING INSTRUCTIONS & INSTALLATION

FUNCTION	OPERATION SPECIFICATION	REMARK
Cool	Fresh Select Zone temp. is controlled by interlock with the set temp. (33.8°F ~ 44.6°F) of the Fridge compartment	
Fresh	Fresh Select Zone, 37.4°F operation	
Soft Freeze	Fresh Select Zone, 23°F operation	
Chill	Fresh Select Zone, 30.2°F operation	

3-12) Test Functions (Forced Operation Start and Forced Defrosting Functions)

- If the Fresh Select Zone key and the F compartment key on the PANEL PCB are simultaneously pressed for more than 8 seconds, then the TEST MODE is entered. Now, whether the F compartment key, the R compartment key, the Arctic Select Zone key or the Fresh Select Zone key is pressed, it operates as a TEST KEY.
- If a TEST KEY is pressed, the test function is changed in sequence to forced operation start (FF) → forced R, CR defrosting → forced R, CR,F, CF defrosting → test cancellation (normal operation) → forced operation start.

To cancel the function during test function operation, it is the most desirable way to turn on the power again after turning it off.

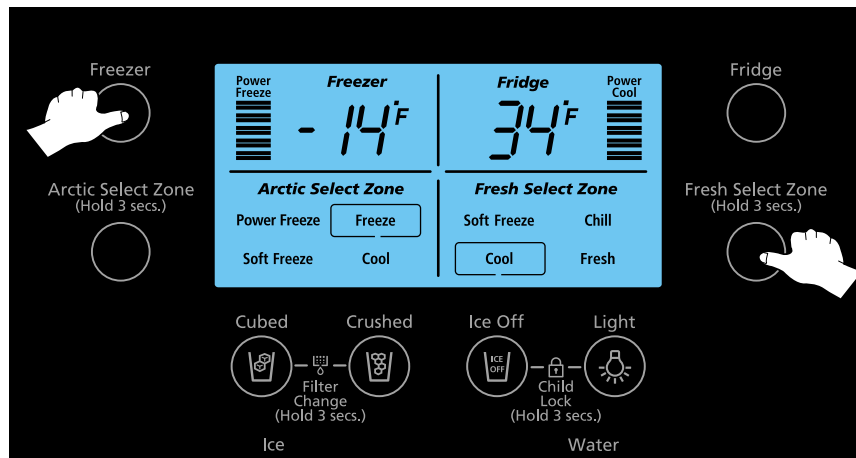

OPERATING INSTRUCTIONS & INSTALLATION

1) Forced Start Operation Function

- 1-1) Forced start operation is selected if the test key is pressed once while in the test mode. At that time the buzzer executes an alarm by making a beep sound.
- 2-1) If forced start operation is selected, then COMP. operates immediately without a 5 minute delay, regardless of operating mode. If it is during defrosting, defrosting shall promptly stop.
- 3-1) If forced start operation is selected, then the COMP. and F FAN perform a PULL-DOWN operation for 24 hours while the R compartment is controlled by the set temperature.
- 4-1) The forced start operation is performed continuously performed until completed, canceled or converted to an other mode (forced F, R, CF, CR defrosting).
- 5-1) If the forced start operation is selected, then along with it, a automatic selection is made for the F compartment "-13°F" and for the R compartment "33.8°F" These settings are not changed (maintains "-13°F" and "33.8°F") even if forced defrosting or test cancellation is selected after more than 1 minute elapses under the condition where forced start operation has been selected Nevertheless the setting are restored to the temperatures that were set before the change to "-13°F" and "33.8°F" if forced defrosting or test cancellation is selected before 1 minute elapses from the time when the forced start operation was selected.
- 6-1) **If forced start operation is finished(24 hours), then F, CF compartment defrosting is executed regardless of previous condition.**
- 7-1) Next, it proceeds normal defrosting opera according to CASE judgment, performing defrosting of the R compartment defrosting.
- 8-1) If randomly canceled during forced start operation (by cancellation mode), the COMP. ON time period during the forced start operation is also added to the accumulation to be considered for the defrosting period.
- 9-1) The power freezing and power refrigeration functions do not work during forced start operation. If any of these functions is selected, the LED display for the selected POWER function turns off spontaneously after approximately 10 seconds..

2) Forced Defrosting Function

- 1-1) If test button is pressed a second time, then R compartment / CR compartment defrosting is executed, and if the test button is pressed a third time, then simultaneous defrosting of F, CF, R, CR compartments is executed, and a beeping sound alarm is also executed.
- 2-1) The beeping sound alarm is executed until completion time of the heating and pause time.

3) Test Cancellation Mode





- 3-1) If the display panel is converted to the test mode and the test button is pressed once more, under the simultaneous defrosting condition, then defrosting of freeze and refrigeration partitions is canceled simultaneously to return to normal operation. Or if main power is turned on after turnoff, then all test functions are canceled.

OPERATING INSTRUCTIONS & INSTALLATION

3-13) Alarm Function

1) Button Touch Sound (Refer to Sounds Table)

1-1) When touching each button on the control panel, an input confirmation sound is generated (see the following table), according to each operating condition.

Description	Sound Group	Sound Pattern
When selecting power freezing / power refrigeration / lock / stop icing / Filter Reset / light	SUB ON (Function Selection)	
When canceling power freezing / power refrigeration / lock / stop icing / light	SUB OFF (Function Cancellation)	
When selecting the cube ice / crushed ice When selecting the Arctic Select Zone function When selecting the Fresh Select Zone function	MODE (Function Change "Ding")	
When selecting the refrigerator compartment / freezer compartment	VERTICAL (Temperature Setting)	
When water supply is finished, in the ice maker test mode	Ding Dong Sound	Existing Ding Dong Sound
Door-open alarm sound	ALERT(Warning Sound)	

1-2) If several plural buttons are pressed simultaneously or in case of wrong button operation, an input confirmation sound is not generated.

2) DOOR-OPEN Alarm Sound

2-1) If F compartment, R compartment, Arctic Zone, or Fresh Zone door remains open for 2 minutes in row, alarm sound is generated by 10 times.

2-2) If the door open condition is maintained even longer, the operation recycles generating the alarm sound 10 times per 1 minute period.

2-3) The alarm sound stops readily if the refrigerator compartment and the freezer compartment are both closed.

3-14) Communication Error Display Function

1) Display Function at PANEL ↔ MAIN MICOM Communication Error

1-1) If 10 seconds elapse without response, after transmission of a communication request from the PANEL MICOM, the PANEL PCB repeats ON/OFF until the communication error is cleared (by repeating ALL ON for 0.5 second and ALL OFF for 0.5 second).

2) Display Function at MAIN ↔ LOAD MICOM Communication Error

2-1) If 10 seconds elapse without response, after transmission of a communication request from the MAIN MICOM to the LOAD [SUB(ORDINATE)] MICOM, then the PANEL PCB DISPLAY repeats ON/OFF until the communication error is cleared (by repeating ALL ON for 0.5 second and ALL OFF for 0.5 second).

OPERATING INSTRUCTIONS & INSTALLATION

3-15) Self-Diagnostics Function

1) Self-Diagnostics Function at Initial POWER ON

- 1-1) MICOM judges internally by itself within several seconds whether there is any error in temperature sensor if electricity is initially applied to the refrigerator.
- 1-2) If an inferior sensors are found as the result of Self-Diagnostics operation, all relevant display LEDs are flickering at 0.5 second interval. But no alarm sound is generated separately.
- 1-3) Under the condition where a display LED flickers due to a bad sensor occurrence, only the Self-Diagnostics function buttons are recognized (the freezing setting + the Refrigeration setting keys shall be pressed simultaneously for 8 seconds) and normal display does not proceed while temperature control is executed only by an emergency operation.
- 1-4) The above status is canceled automatically in case an error with the Self-Diagnostics occurred, if all bad sensors would have been repaired, or if the freezing setting + the Refrigeration setting keys are pressed simultaneously for 8 seconds.

Press the keys simultaneously for 8 seconds.

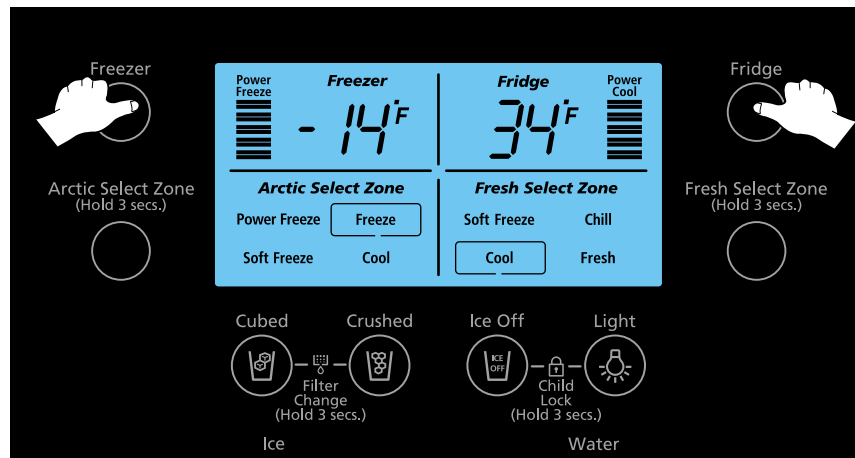

2) Self-Diagnostics Function during Normal Operation

- 2-1) If the freezing setting + the Refrigeration setting keys are pressed simultaneously for 6 seconds, during normal refrigerator operation, the temperature-setting display flickers ALLON/OFF with 0.5 second interval for about 2 seconds. The Self-Diagnostics function is selected when the freezing setting + the Refrigeration setting keys are pressed simultaneously for about 8 seconds, including the 2 seconds during which the LED repeats ON/OFF.
- 2-2) When the Self-Diagnostics mode is mode, the buzzer makes a ding-dong sound.
- 2-3) If the Self-Diagnostics mode is entered, then all LCDs turn off except relevant LCDs where function abnormality arose so as to display their own defect occurrence (cf. Self-Diagnostics Check list below).
- 2-4) Display of error occurrence returns to normal condition after 30-second duration of error display regardless of repair. (Buzzer sound off ding dong when returning to normal condition)
- 2-5) Button input is not accepted during Self-Diagnostics execution.
- 2-6) Among the above Self-Diagnostics items, ICE MAKER SENSOR AND ICE MAKER FUNCTION ERROR CHECKS are only executed in case the user has selected ICE MAKER model option as an external attachment type.

OPERATING INSTRUCTIONS & INSTALLATION

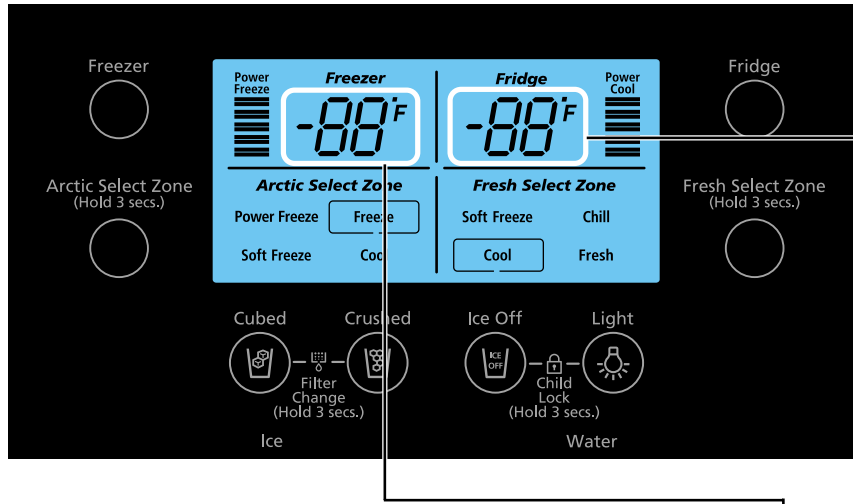

* Self-Diagnostics Checklist



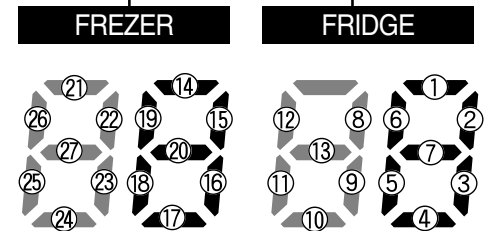











No	BAD ITEM	TROUBLE STATUS
1	I/M-SENSOR	Ice maker sensor system abnormality
2	R-SENSOR	R Compartment sensor system abnormality
3	R-DEF-SENSOR	System abnormality of defrosting sensor for of R compartment
4	R-FAN ERROR I/M	Fan motor system abnormality in R compartment
5	FUNCTION ERROR	Ice maker operation abnormality
6	-	
7	R-DEFROSTING ERROR	Abnormality in defrosting system for R compartment
8	CR-SENSOR	CR compartment sensor system abnormality
9	CR-DEF-SENSOR	Abnormality in defrosting sensor system for CR compartment
10	CF-DEF-SENSOR	Abnormality in defrosting sensor system for CF compartment
11	CR-DEFROSTING ERROR	Abnormality in defrosting system for CR compartment
12	CF-DEFROSTING ERROR	Abnormality in defrosting system for CF compartment
13	WATER HEATER ERROR	Water heater system abnormality
14	EXT-SENSOR	External atmosphere sensor system abnormality
15	F-SENSOR	F compartment sensor system abnormality
16	F-DEF-SENSOR	System abnormality of defrosting sensor for F compartment
17	F-FAN ERROR	Fan motor system abnormality in F compartment
18	C-FAN ERROR	Fan motor system abnormality in machine compartment
19	CF-SENSOR	CF compartment sensor system abnormality
20	F-DEFROSTING ERROR	Abnormality in defrosting system for F compartment
21	CF-FAN ERROR	Fan motor system abnormality in CF compartment
22	CR-FAN ERROR	Fan motor system abnormality in CR compartment
23	-	-
24	ICE PIPE HEATER ERROR	Ice pipe heater system abnormality
25	Uart COMMUNICATION ERROR	Electric power line communication error
26	L—M COMMUNICATION ERROR	Bad communication between LOAD—MAIN MICOM
27	P—M COMMUNICATION ERROR	Bad communication between PANEL—MAIN MICOM







If a corresponding LED flickers, it means abnormality of sensor and part.

OPERATING INSTRUCTIONS & INSTALLATION

* Error items of self-diagnostics

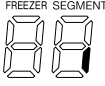
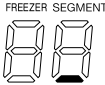
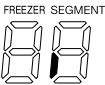
No	ITEM	TROUBLE	REMARK
1	I/M-SENSOR	Electric wire cut, short-circuit, contact failure, sensor housing missing, while in case of displaying a temperature defect, it is only displayed when the sensor detected temperature is not lower than 122°F nor higher than -58°F	FRIDGE SEGMENT 
2	R-SENSOR	Electric wire cut, short-circuit, contact failure, sensor housing missing, while in case of displaying a temperature defect, it is only displayed when the sensor detected temperature is not lower than 122°F nor higher than -58°F	FRIDGE SEGMENT 
3	DEFROSTING SENSOR OF R COMPARTMENT	Electric wire cut, short-circuit, contact failure, sensor housing missing, while in case of displaying a temperature defect, it is only displayed when the sensor detected temperature is not lower than 122°F nor higher than -58°F	FRIDGE SEGMENT 
4	R-FAN ERROR	AN error is displayed when there is a contact failure on the feedback signal line, a motor wire missing or a defect of the motor itself, when operating the relevant fan motor.	FRIDGE SEGMENT 
5	I/M FUNCTION ERROR	An error is displayed when there is bad horizontality and bad ice tray more than twice for each item of the ice maker kit. ** Pertinent only to dispenser models (external attachment type).	FRIDGE SEGMENT 
6	-		FRIDGE SEGMENT 
7	R-DEFROSTING ERROR	Error occurs and is displayed when regarding the R compartment defrosting heater, there is an electric wire cut, short-circuit, contact failure, sensor housing missing, or defective temperature fuse. A defect is displayed if defrosting is not finished after continuous heating for more than 70 min, for the R compartment.	FRIDGE SEGMENT 
8	CR SENSOR	Electric wire cut, short-circuit, contact failure, sensor housing missing, while in case of displaying a temperature defect, it is only displayed when sensor detection temperature is not lower than 122°F nor higher than -58°F.	FRIDGE SEGMENT 
9	DEFROSTING SENSOR OF CR COMPARTMENT	Electric wire cut, short-circuit, contact failure, sensor housing missing, while in case of displaying a temperature defect, it is only displayed when sensor detection temperature is not lower than 122°F nor higher than -58°F.	FRIDGE SEGMENT 
10	DEFROSTING SENSOR OF CF COMPARTMENT	Electric wire cut, short-circuit, contact failure, missing of sensor housing, while in case of display of defect by temperature, it is only displayed when sensor detection temperature is not lower than 122°F or not higher than -58°F	FRIDGE SEGMENT 
11	CR-DEFROST ERROR	Error occurs and is displayed when regarding the CR compartment defrosting heater, there is an electric wire cut, short-circuit, contact failure, sensor housing missing, or defective temperature fuse. A defect is displayed if defrosting is not finished after continuous heating for more than 70 min, for the CR compartment.	FRIDGE SEGMENT 
12	CF-DEFROST ERROR	Error occurs and is displayed when regarding the CF compartment defrosting heater, there is an electric wire cut, short-circuit, contact failure, sensor housing missing, or defective temperature fuse. A defect is displayed if defrosting is not finished after continuous heating for more than 70 min, for the CF compartment.	FRIDGE SEGMENT 
13	WATER HEATER ERROR	An Error is displayed in case of water heater housing missing or electric wire cut.	FRIDGE SEGMENT 
14	EXT-SENSOR	Electric wire cut, short-circuit, contact failure, sensor housing missing, while in case of displaying a temperature defect, it is only displayed when sensor detection temperature is not lower than 122°F nor higher than -58°F.	FREEZER SEGMENT 
15	F-SENSOR	Electric wire cut, short-circuit, contact failure, sensor housing missing, while in case of displaying a temperature defect, it is only displayed when sensor detection temperature is not lower than 122°F nor higher than -58°F.	FREEZER SEGMENT 

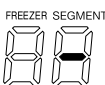
OPERATING INSTRUCTIONS & INSTALLATION

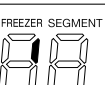
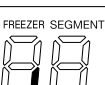
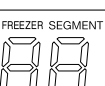
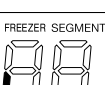
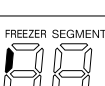
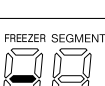
No	ITEM	TROUBLE	REMARK
16	F-DEF-SENSOR	Electric wire cut, short-circuit, contact failure, sensor housing missing, while in case of displaying a temperature defect, it is only displayed when sensor detection temperature is not lower than 122°F nor higher than -58°F.	<small>FREEZER SEGMENT</small> 
17	F-FAN ERROR	Error is displayed in case there is a contact failure on the feedback signal line, motor wire missing or defect of the motor itself, when operating the relevant fan motor.	<small>FREEZER SEGMENT</small> 
18	C-FAN ERROR	Error is displayed in case there is contact failure on the feedback signal line, motor wire missing or defect of the motor itself when operating the relevant fan motor.	<small>FREEZER SEGMENT</small> 
19	CF-SENSOR	Electric wire cut, short-circuit, contact failure, sensor housing missing, while in case of displaying a temperature defect, it is only displayed when sensor detection temperature is not lower than 122°F nor higher than -58°F	<small>FREEZER SEGMENT</small> 
20	F-DEFROSTING ERROR	Error occurs and is displayed when regarding the F compartment defrosting heater, there is a electric wire cut, short-circuit, contact failure, of sensor housing missing, or defective temperature fuse. A defect is displayed if defrosting is not finished after continuous heating for more than 80 min, for the F compartment.	<small>FREEZER SEGMENT</small> 
21	CF-FAN ERROR	Error is displayed in case there is a contact failure on the feedback signal line, motor wire missing or defect of the motor itself, when operating the relevant fan motor.	<small>FREEZER SEGMENT</small> 
22	CR-FAN ERROR	Error is displayed in case there is a contact failure on the feedback signal line, motor wire missing or defect of the motor itself, when operating the relevant fan motor.	<small>FREEZER SEGMENT</small> 
23	-		<small>FREEZER SEGMENT</small> 
24	ICE PIPE HEATER ERROR	Error is displayed in case of ice pipe heater housing missing or electric wire cut.	<small>FREEZER SEGMENT</small> 
25	Uart COMMUNICATION ERROR	Communication error with the electric power cord MODEM	<small>FREEZER SEGMENT</small> 
26	L ↔ M COMMUNICATION ERROR	Whole letters of the LCD panel repeat ON/OFF and buzzer generates alarm sound if communication between MICOM MAIN LOAD is not achieved due to an interruption of more than 10 seconds.	<small>FREEZER SEGMENT</small> 
27	P ↔ M COMMUNICATION ERROR	Whole letters of the LCD panel repeat ON/OFF and buzzer generates alarm sound if communication between MICOM MAIN PANEL is not achieved due to an interruption of more than 10 seconds.	<small>FREEZER SEGMENT</small> 

OPERATING INSTRUCTIONS & INSTALLATION

3-16) Load Condition Display Function

- 1) If the freezing setting + the refrigeration setting keys are pressed simultaneously for about 6 seconds under normal operation condition, the freezer compartment and the refrigerator compartment temperature setting displays go on ALL ON/OFF for about 2 seconds with a 0.5 second interval.
- 2) If the freezing setting + the refrigeration setting keys are pressed simultaneously then released, and the Fresh Zone setting key is pressed (to generate a ding-dong sound), the load status display mode is introduced.
- 3) Load status display mode tells what kind of load is output by the current MICOM signal. It tells only that a MICOM signal has been output but it does not confirm whether or not the load actually operates. So even if the display output shows that the load is operating, in reality the load might not operate due to load abnormality, bad relay on PCB etc. while as such this function may be used in A/S by application.
- 4) Load status display function is maintained for only 30 seconds after which it automatically returns to normal condition.
- 5) Relevant displays about load status is as follows.

* LOAD MODE CHECKLIST

No	LOAD ITEM	LOAD STATUS
1	R-FAN HIGH	R-FAN High speed rotation operation display
2	R-FAN LOW	R-FAN Low speed rotation operation display of R-FAN
3	R-DEF-HEATER	Displays operation of the R compartment defrosting heater
4	START MODE	Operation stage display (not important)
5	OVERLOAD MODE	When ambient temperature is not higher than 93.2°F
6	LOW TEMP. MODE	When ambient temperature is not lower than 62.6°F
7	DISPLAY MODE	During display mode operation
8	COMP	COMP. operation display
9	F-FAN HIGH	F-FAN high speed rotation operation display
10	F-FAN LOW	F-FAN low speed rotation operation display
11	F-DEF-HEATER	Displays operation of the F compartment defrosting heater
12	C-FAN HIGH	C-FAN High speed rotation operation display
13	C-FAN LOW	C-FAN low speed rotation operation display
14	DISPENSER-HEATER	Dispenser heater operation display
15	R-VALVE	Is it lighted when the R-VALVE is OPEN
16	CR-FAN	CR-FAN operation display
17	CR-DEF-HEATER	Operation display of CR compartment defrosting heater
18	ICE-PIPE-HEATER	ICE-PIPE heater operation display
19	F-VALVE	Is it lighted when the F-VALVE is OPEN
20	CF-FAN	CF-FAN operation display
21	CF-DEF-HEATER	Displays operation of the CF compartment defrosting heater
22	WATER-HEATER	Water heater operation display
-	ORDINARY CONDITION	When both no. 5 and 6 are lights-out (64.4°F ~93.2°F)

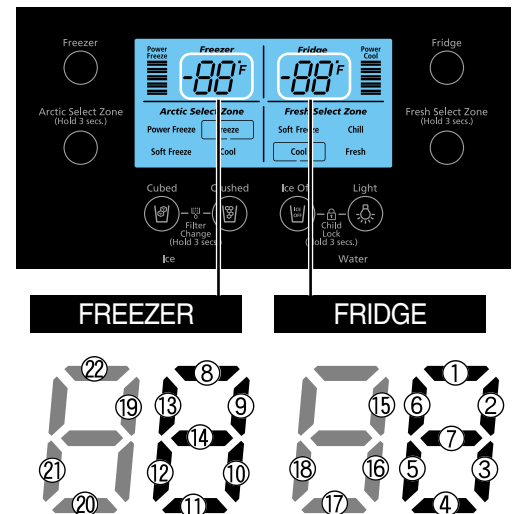

OPERATING INSTRUCTIONS & INSTALLATION

3-17) Operation Condition Recovery Function in Case of Power Outage

- 1) In case of momentary electricity interruption, customer's NON-SENSE CALL would arise if PANEL DISPLAY is initialized. To prevent this, initialization or recovery(of previous operation status) is operated by way of judging the temperature in the freezer compartment.
- 2) If the temperature in the freezer compartment is judged to be below 41°F at initial POWER ON, it is judged to be a momentary electricity interruption during operation, and functions(power freezing, power refrigeration, setting of the freezer compartment, setting of the refrigerator, setting of Arctic Select Zone, setting of Fresh Select Zone, ice type, lock condition, etc.) related to PANEL DISPLAY are restored.
- 3) If the temperature in freezer compartment is judged to be above 41°F at initial POWER ON, it is judged to be a long-term electricity interruption, and PANEL DISPLAY is initialized. (Automatic settings: freezer compartment at -2°F , refrigerator compartment at 38°F , Arctic Select Zone to freeze, and Fresh Select Zone to cool)

3-18) Option Setting Function

Changing to Optional Mode

- If the Arctic Select Zone Setting Key + Refrigerator Compartment Key is simultaneously pressed for about 12 seconds under normal operating condition, display is converted to an option setting mode.



OPERATING INSTRUCTIONS & INSTALLATION

Key Functions After Converting to Option Mode

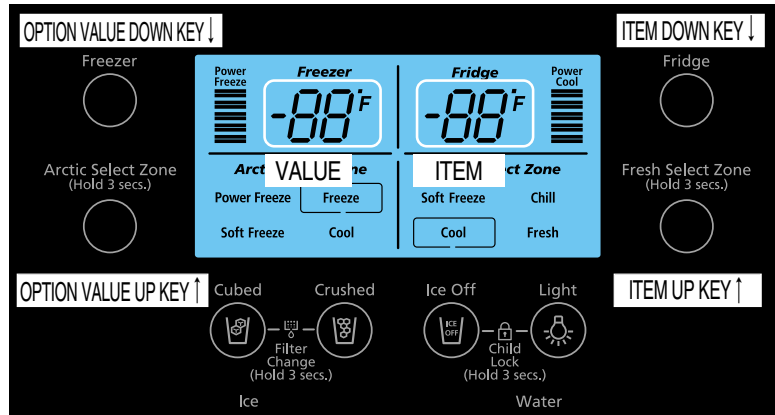

KEY	FUNCTION
Refrigerator Compartment key	ITEM DOWN ↓
Fresh zone, Freezer keys	ITEM UP ↑
Freezer Compartment key	OPTION VALUE DOWN ↓
Arctic Select Zone key	OPTION VALUE UP ↑

1) For example if you wish to shift the freezer compartment standard temperature down by 37.4°F by adjusting option, you may proceed as follows. As this function is to change standard temperature, if current standard temperature of the Freezer Compartment is -0.4°F and is lowered by 37.4°F by using the option, then standard temperature is adjusted at -5.8°F. So in case where temperature option has been changed, internally it operates at actual standard temperature -5.8°F even if it is set at -0.4°F on the panel. Therefore, adjusting standard temperature by 26.6°F indicates that the temperature is adjusted down by 26.6°F from standard temperature that has been set on control panel.

※ **Note)** In principle, product is delivered from warehouse with all data for optional functions cleared. Namely, it is delivered from warehouse with all set values set to "0". However, since some part of set values could have been changed during mass production for quality improvement purpose, please always confirm the quality information and so on.

- 2) If the Arctic Select Zone Setting Key + Refrigerator Compartment Key is simultaneously pressed for about 12 seconds under normal operating condition, display is converted to an option setting mode.
- 3) After changing to option mode, display of "0" is lighted on the freezer compartment and refrigerator compartment respectively. (Though it is supposed to be delivered from warehouse as such "0" for freezer compartment and "0" for refrigerator compartment), the standard set values could have been changed during mass production for quality improvement purpose, and delivered as such.)temperature display.

OPERATING INSTRUCTIONS & INSTALLATION

4) If "6" is set as shown in the following option table for the freezer compartment after setting at "0" for the refrigerator compartment, standard temperature of freezer compartment is lowered by -26.6°F. (Refer to the figure of temperature change for freezer compartment)

: If you wait 20 seconds after completing the adjustment, the MICOM saves the set value on EEPROM and returns to normal display and the option setting mode is canceled.

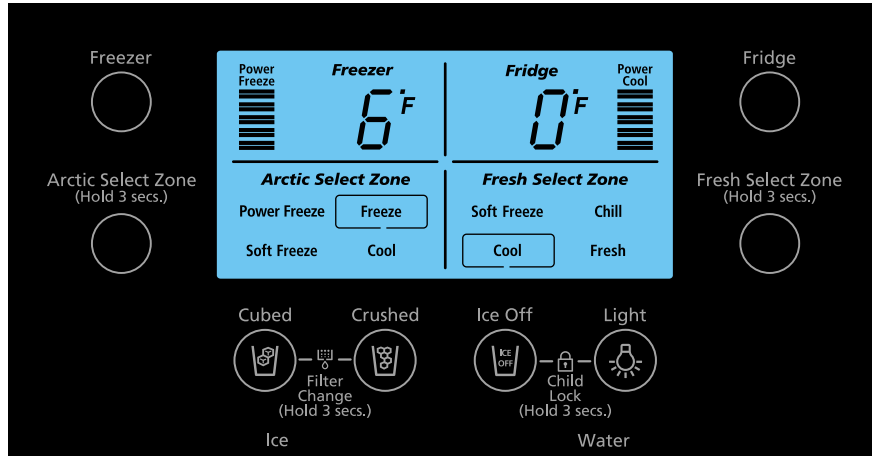

5) The above method of option change is applied to all models regardless of ICE DISPENSER/WATER attachment without discrimination.

6) Temperature control of refrigerator compartment, water supply rate control, ice maker sensor temperature change, CR compartment temperature control, etc. are available in the same manner as above.

7) Abstain from making random changes at your will except in special cases because every refrigerator product is delivered from the factory with the option functions set in EEPROM. And if you change a setting option at your will, don't turn off electric power before recovery to normal display because the option function settings are only finished if the display returns to normal 20seconds after your setting change.

1) Temperature Change Table for the Freezer Compartment

※ **Note)** Though there are other items adjustable by option, do not set options other than those of A/S MANUAL contents because other items are related to refrigerator control functions. (please don't set options other than those shown in the A/S MANUAL contents.)

OPERATING INSTRUCTIONS & INSTALLATION

Set Value	Option Value
F Compartment Set value for temperature display	
0	32°F
1	31.1°F
2	30.2°F
3	29.3°F
4	28.4°F
5	27.5°F
6	26.6°F
7	25.7°F
8	32.9°F
9	33.8°F
10	34.7°F
11	35.6°F
12	36.5°F
13	37.4°F
14	38.3°F
15	39.2°F

Application Example) When to lower the reference temperature of the Freezer Compartment to 26.6°F.

KEY	Temperature Shift for the Freezer Compartment
MODEL	Common for all models
Option Item	Position: R compartment temperature display



2) Temperature Change Table for the Refrigerator Compartment

Set Value	Option Value
R Compartment Set value for temperature display	
0	32
1	31.1°F
2	30.2°F
3	29.3°F
4	28.4°F
5	27.5°F
6	26.6°F
7	25.7°F
8	32.9°F
9	33.8°F
10	34.7°F
11	35.6°F
12	36.5°F
13	37.4°F
14	38.3°F
15	39.2°F

Application Example) When to heighten the reference temperature of the Refrigerator Compartment to 34.7°F.

KEY	Temperature Shift for the Refrigerator Compartment
MODEL	Common for all models
Option Item	Position: R compartment temperature display

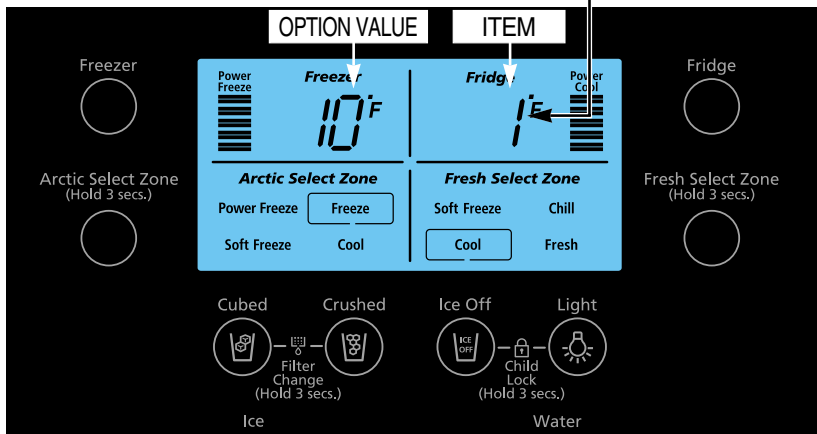

OPERATING INSTRUCTIONS & INSTALLATION

■ The following options apply only to models attached with ice maker.

In case of basic model, the following items cannot be set.

3) Water Supply Quantity Control Function, for the Ice Maker

Automatic water supply quantity control option by flow sensor.

Setting Item	Display Position
Automatic water supply quantity control for Ice Maker	2

Automatic Water Supply Quantity	Option Value (Temperature Display for the Freezer Compartment)
95 cc	0
85 cc	1

Application Example) When changing the supply water quantity to 85 cc

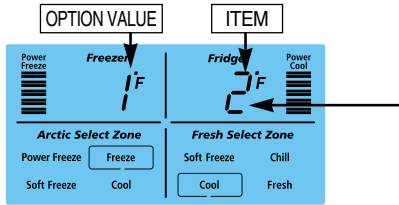

5) Temperature Change of Ice Making Sensor for Ice Maker

This is the judgment reference temperature for the ice making sensor to check whether the ice in ICE MAKER has been completely frozen.

Setting Item	Display Position (Temperature display of the Refrigerator compartment)
Standard temperature control for ice maker sensor	4

Sensing temperature of ice maker sensor	Display of the freezer compartment
1.4°F	0
3.2°F	1
5°F	2
6.8°F	3
8.6°F	4
10.4°F	5
-0.4°F	6
-2.2°F	7

4) Function to Control the Ice Tray Wait Time for Ice Maker

Setting Item	Display Position (Temperature display of the Refrigerator compartment)
Ice extraction wait time control for ice maker	3

Wait time for ice tray	Display of the freezer compartment
58 minutes	0
57 minutes	1
56 minutes	2
55 minutes	3
54 minutes	4
53 minutes	5
52 minutes	6
51 minutes	7
50 minutes	8
49 minutes	9
48 minutes	10
47 minutes	11
46 minutes	12
45 minutes	13
59 minutes	14
60 minutes	15

6) CR Room Temperature Shift Function

- This option alters the standard temperature for the CR compartment.

Setting Item	Display Position (Temperature display of the Refrigerator compartment)
CR Compartment Temperature Shift (Standard temp. change)	20

CR Compartment Temperature Shift	Display on the freezer compartment
32°F	0
31.1°F	1
30.2°F	2
29.3°F	3
32.9°F	4
33.8°F	5
34.7°F	6
35.6°F	7

5. DISASSEMBLY AND REASSEMBLY

5-1) Door Assy

5-2) Door Sub Parts

Control Panel.....	47
Door Gasket.....	47
Door Handle.....	47

5-3) Refrigerator Compartments

Refrigerator Door Light Switch.....	48
Tempered Glass Shelf.....	48
Refrigerator Light.....	48
Plastic Drawers in the Refrigerator.....	48
Gallon Door Bin	48

5-4) Freezer Compartments

Door Bin in Freezer.....	49
Freezer Door Light Switch.....	49
Plastic Drawer in Freezer.....	49
Freezer Shelf.....	49
Ice Dispenser & Ice Maker.....	50
Freezer Light.....	50
Auger Motor Case.....	51
Upper Ductwork.....	51
Partition in the Freezer.....	52
Evaporator Cover.....	52
Evaporator Fan Motor in Arctic Select Zone.....	53
Evaporator Fan Motor.....	53
Evaporator in Freezer.....	53
Freezer Thermistor.....	54
Ice-Maker Thermistor.....	54
Water Tank.....	54
Partition in the Refrigerator.....	54
Evaporator Cover in the Refrigerator.....	55
Evaporator Fan Motor in the Refrigerator.....	55
Evaporator in Refrigerator.....	56
Refrigerator Thermistor.....	56
Fresh/Arctic Select Zone Thermistor.....	56
Evaporator Fan Motor in Fresh Select Zone.....	57
Upper Ductwork.....	57
Machine Compartment & Electric Box.....	58
Sub-Condenser.....	58
Water Solenoids.....	58
Condenser Fan	58

DISASSEMBLY AND REASSEMBLY

5-1) Door Assy



Removing the Front Leg Cover

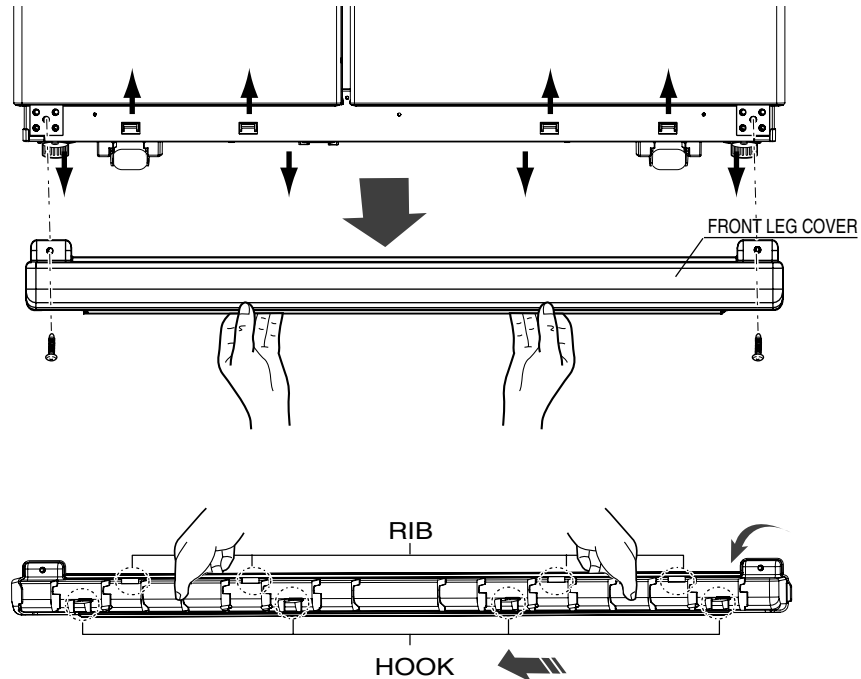

Pull the leg-front-cover down with both hands and remove it by lifting it up with the upper rib. And then, disengage the lower hooks.



Removing the Freezer Door



NOTE

- Lift the door straight up.
- Be careful not to pinch the water tubing and wire harness on the door.
- Place doors on a protected surface.

1) With the door closed, remove the upper hinge cover (①) using a screwdriver, and then push the lever-hook (②) on the connector and disconnect the wires.

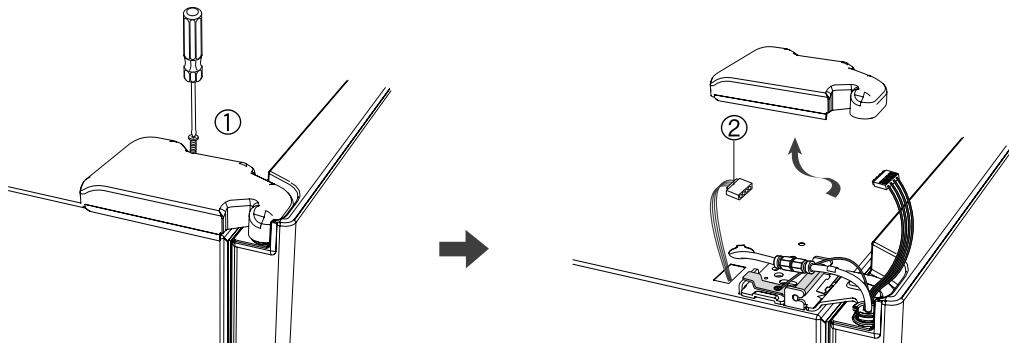

DISASSEMBLY AND REASSEMBLY



Removing the Freezer Door

2) Remove the water tube by pressing the coupler-ring (3) and pulling the water tube (4) away.

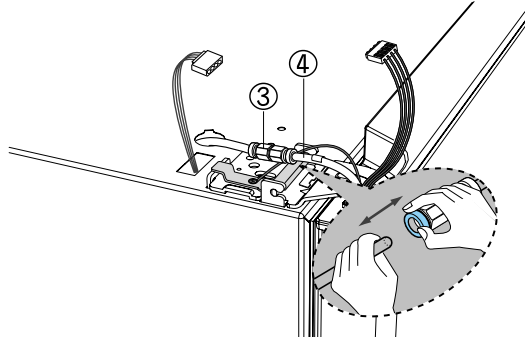

NOTE Do not cut the water tube. Separate it from the coupler.

3) Pull and open the latch (5), and take off the door hinge (6) along the arrow.
Be careful when removing the door to ensure that it does not fall on you.

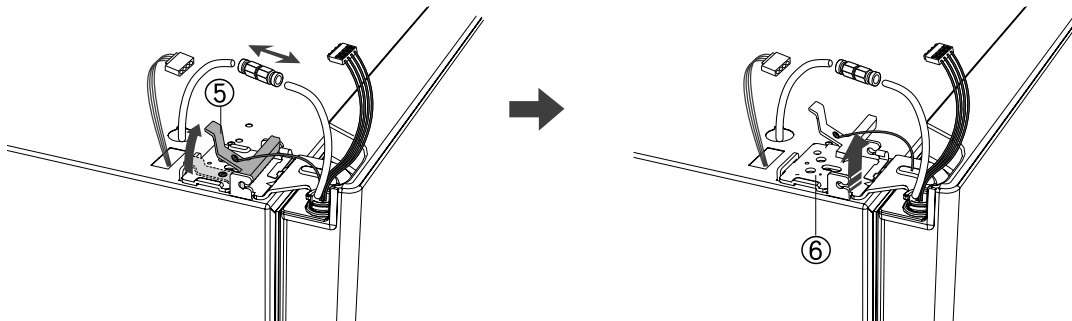

4) Remove the door from the lower hinge (7) by carefully lifting the door (8).

5) Remove hinge screws (9).

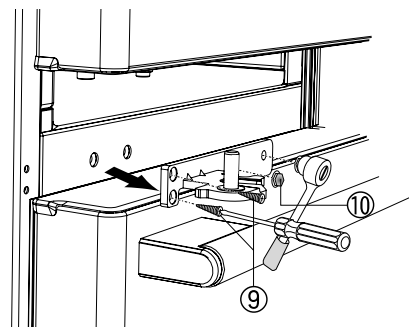
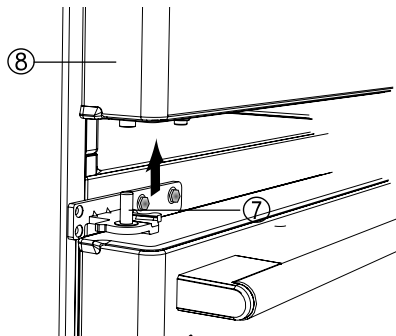



Removing the Refrigerator Door

1) With the door closed, remove the upper hinge cover (①) using a screwdriver.

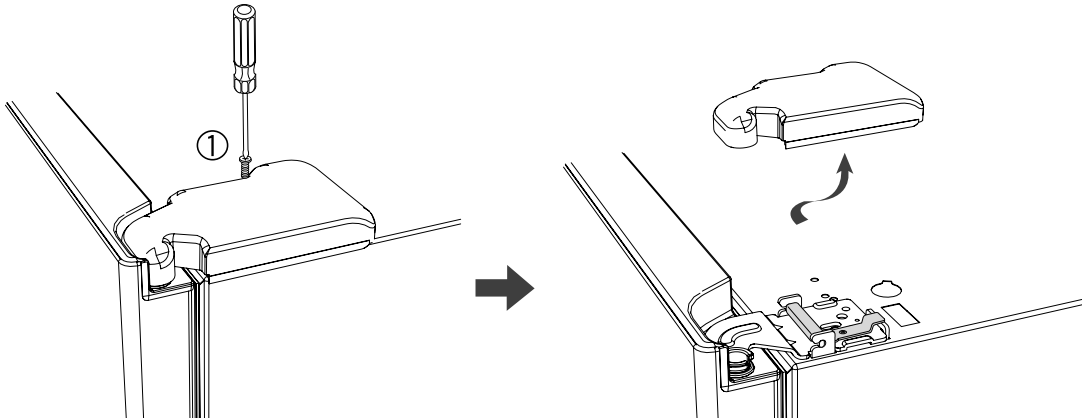

2) Pull and open the latch (②), and take off the door hinge (③) along the arrow.

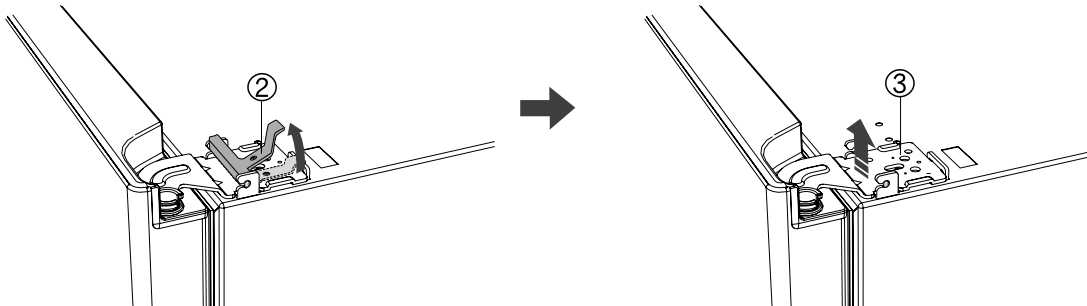

3) Remove the door from the lower hinge (④) by lifting the door (⑤).

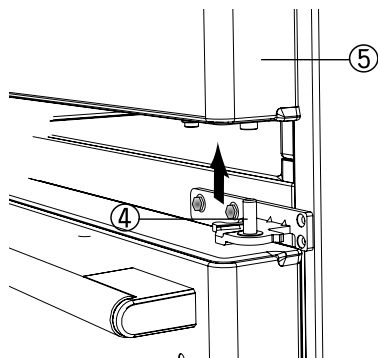

4) Remove the hinge screw (⑥).

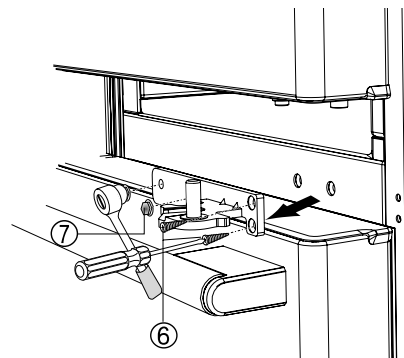



How to Disassemble the Fresh Select Zone Door

1) Open the Fresh Select Zone Door.

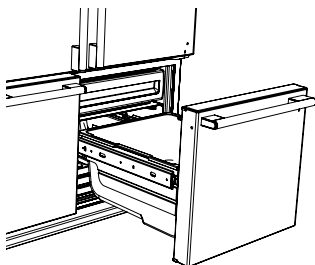

2) Take out the box in the Fresh Select Zone.

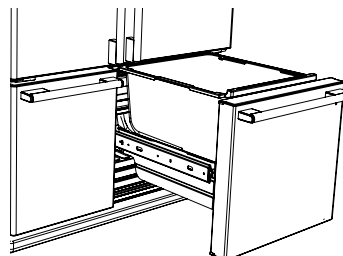

3) Remove two screws holding it to the liner on the left side of the rail.

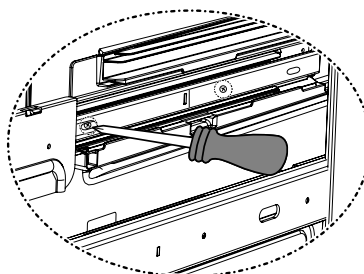
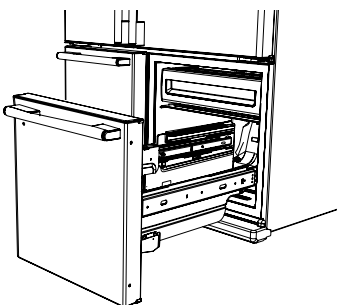

If you pull out the door completely, you will find a screw between bracket rail and liner. Also the other screw is located in the center of rail on the liner.

4) Remove two screws holding it to the liner on the right side of the rail.

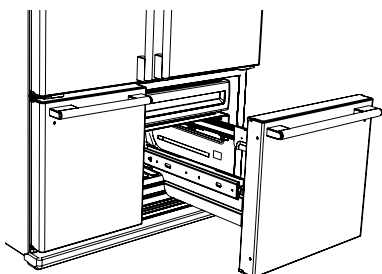

5) Carefully pull out the door to the end to separate it.

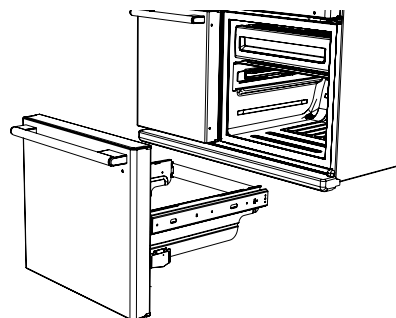



Reattaching the Freezer Door

1) Reattach the hinge screws (1).

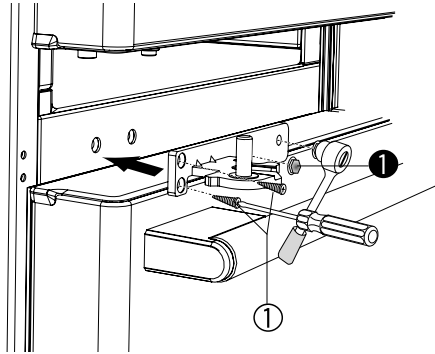

2) Place the hole in the bottom of the door (3) over the hinge (2).

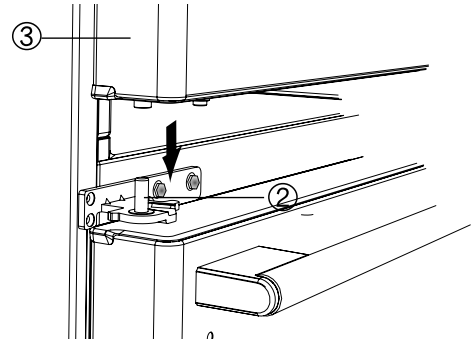

3) Insert the upper hinge shaft (4) into the hole (5). After levelling between the hinge brackets (6). Reattach and close the latch (7).

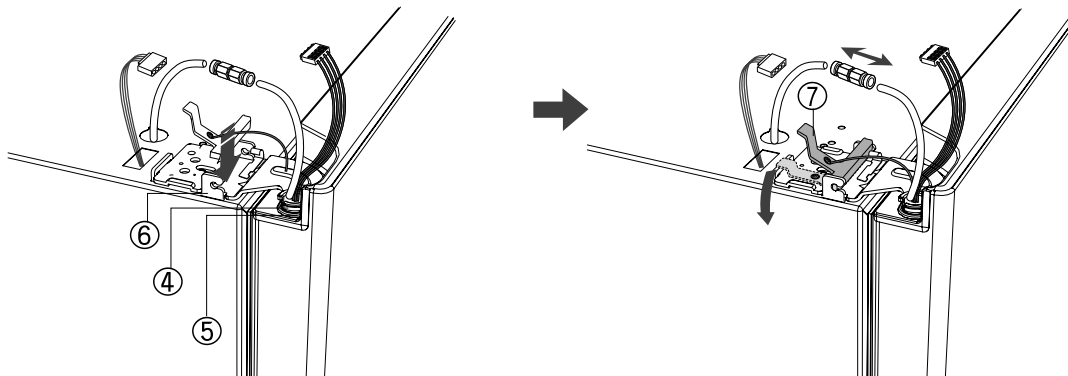

4) Connect the wires (8) and the water tube (9).

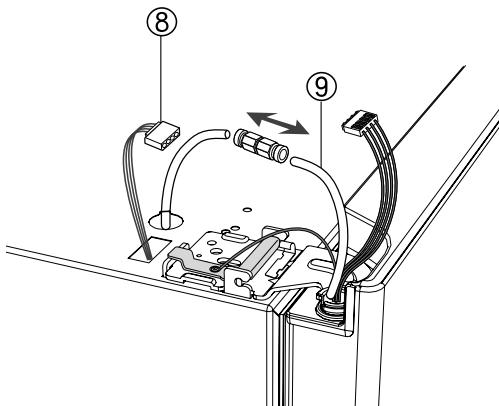

5) Put the front part of the upper hinge cover (10) on the front part of the upper hinge (11) and reattach it from the front part of the upper hinge cover first.

6) Reattach the hinge screw (12).

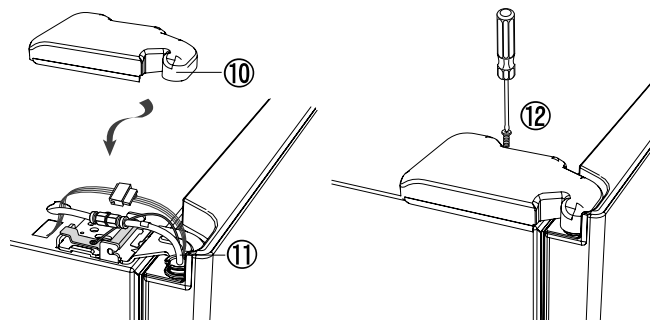

Be sure to insert the water tube and push it to the end.



Reattaching the Refrigerator Door

1) Reattach hinge screws (①).

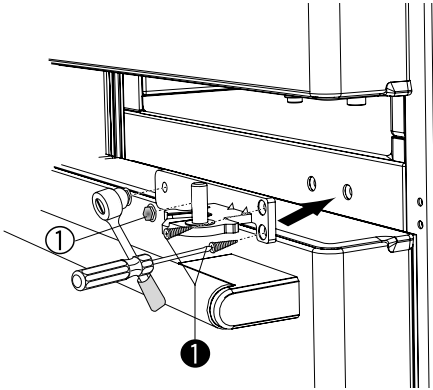

2) Place the hole in the bottom of the door (③) over the hinge (②).

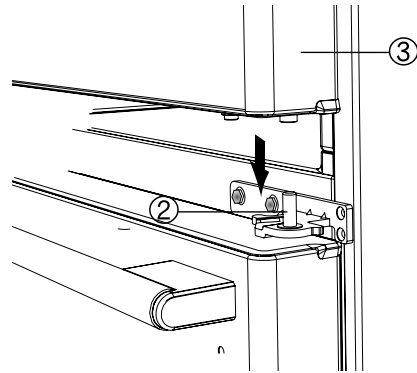

3) Insert the upper hinge shaft (④) into the hole (⑤). After levelling between the hinge brackets (⑥). Reattach and close the latch (⑦) along the arrow.

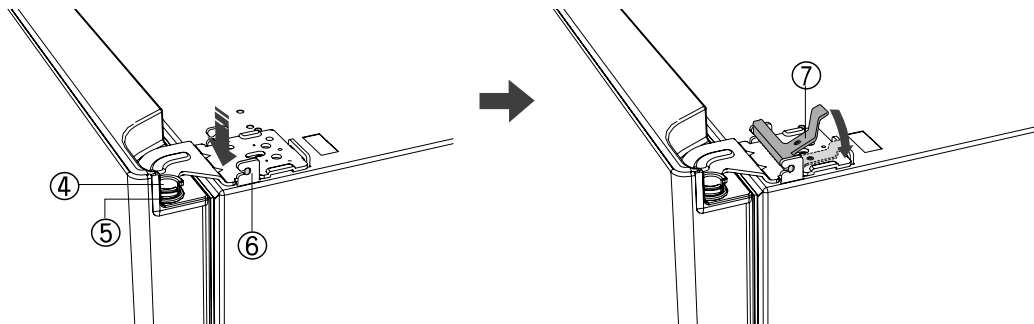

4) Put the front part of the upper hinge cover (⑧) on the front part of the upper hinge (⑨) and reattach it from the front part of the upper hinge cover first.

5) Reattach the hinge screw (⑩).

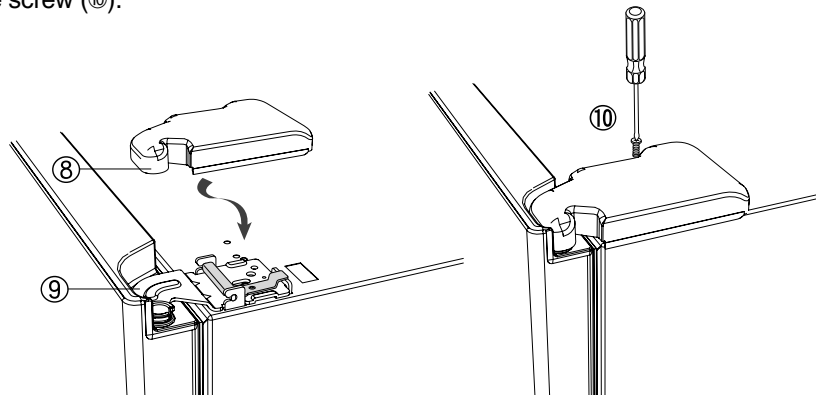



Reattaching the Front Leg Cover

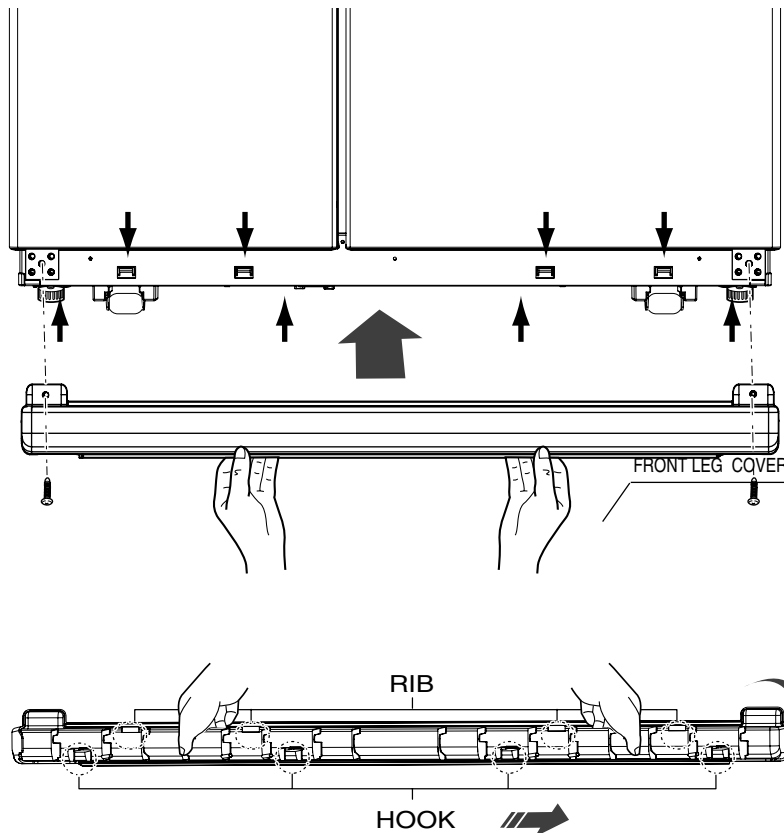

Hold the leg-front-cover with both hands and insert it while sliding the hooks along the guide at the bottom.
Then, lift up the leg-front-cover a little bit and snap the upper ribs into the locking tabs.



LEVELLING

If the front of the appliance is slightly higher than the rear, the door can be opened and closed easier.

1

The appliance tilts down to the left.

Turn the left adjusting leg in the direction of the arrow with a flat head screwdriver until the appliance is level.

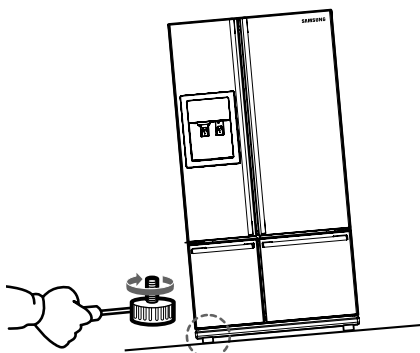

2

The appliance tilts down to the right.

Turn the right adjusting leg in the direction of the arrow with a flat head screwdriver until the appliance is level.

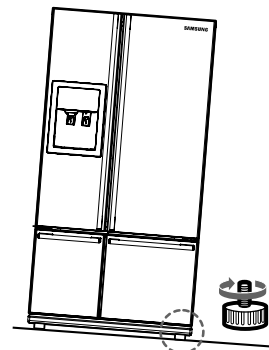



How to Disassemble the Arctic Select Zone Door

1) Open the Arctic Select Zone Door.

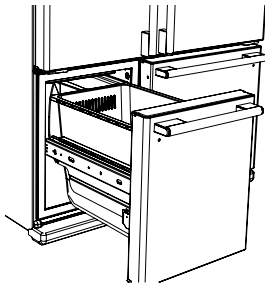

2) Take the box out of the Arctic Select Zone.

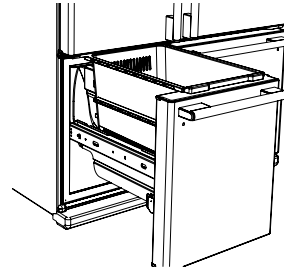

3) Remove two screws holding it to the liner on the left side of the rail.

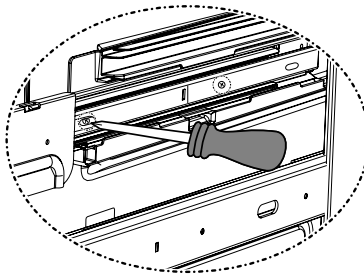
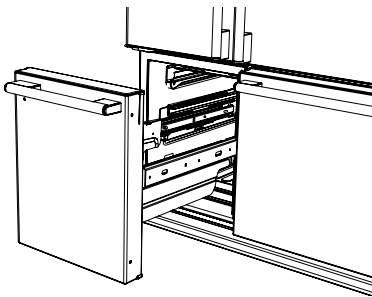

If you pull out the door completely, you will find a screw between bracket rail and liner. Also the other screw is located in the center of rail on the liner.

4) Remove two screws holding it to the liner on the right side of the rail.

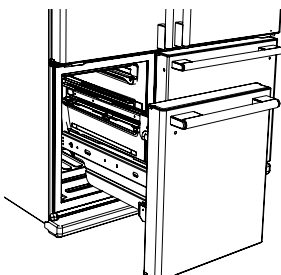

5) Pull out the door carefully to the end to separate it.

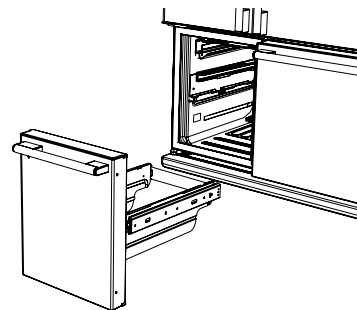

DISASSEMBLY AND REASSEMBLY



Connect the water line to the refrigerator.

- 1) Slip the compression nut and plastic ferrule through the plastic tube.
- 2) After inserting the sleeve, tighten the compression nut onto 1/4" compression fitting(union).



NOTE Do not overtighten the compression nut.

- 3) Slip the compression ferrule and nut on copper (or plastic) tubing as shown. Tighten the compression nut onto the compression fitting(union).
- 4) Turn water on and check for any leakage.

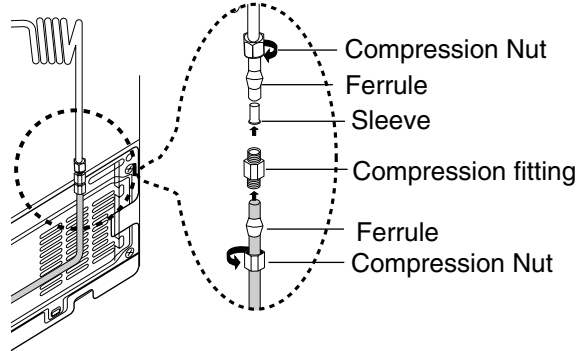

NOTE Water line must be connected to drinkable water only. Cut off 1/4 inch square to prevent leaks when reconnected.



Install the water filter.

- 1) Open the cartridge cover as shown by pulling and pushing up at the front,



NOTE The water filter cartridge is located at the upper right corner of the refrigerator compartment. When the display in the control panel "filter change", it is necessary to be changed the filter cartridge.

- 2) Remove the water filter from the box then position the arrow of the cartridge in line with the cartridge cover.



NOTE Under the high water pressure, water drops may happen. If you put the small tray beneath the hole of filter cover, it will be helpful to clean the shelf.

- 3) Insert the filter as shown and Push until you hear the clicking sound.



NOTE Be sure to align the hook of the filter cartridge and housing.

- 4) Close the filter cartridge cover.



NOTE After changing filter cartridge, drain the first six glassful of water off to remove the trapped air. Do not repeat pushing and pulling, water pressure and trap will make a spurt of water.

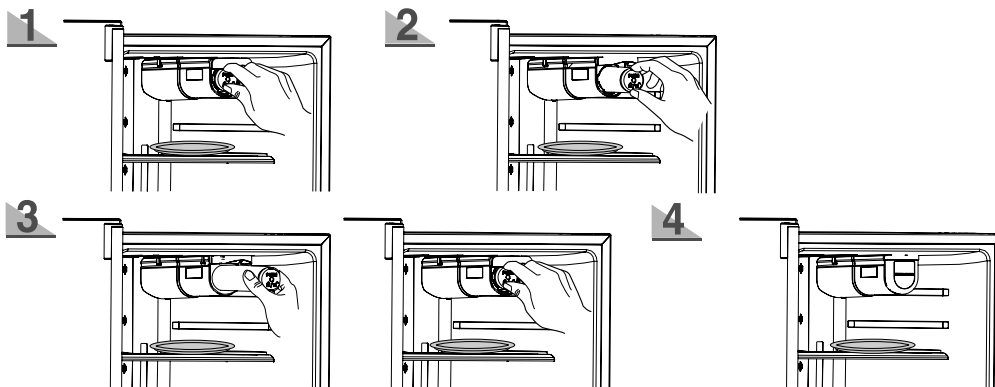

DISASSEMBLY AND REASSEMBLY

5-2) Door Sub Parts

Control Panel

1. Insert a flat-blade screwdriver in the slot as shown, and unlock the tabs.
2. Lift it up as shown
3. Disconnect the wire connector.

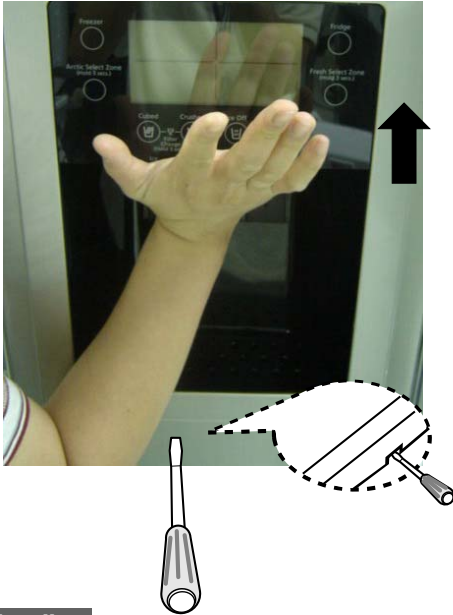

Door Gasket

The door gasket is a molded gasket set into a channel located in the door liner.

1. Open the door.
2. Grasp the gasket and pull it out until the molded gasket separates from the door liner.



Door Handle

The door handles allow access into the refrigerator and freezer. They are front mounted with screws.

1. Remove the screw on the upper part of the handle
2. Lift the handle upward

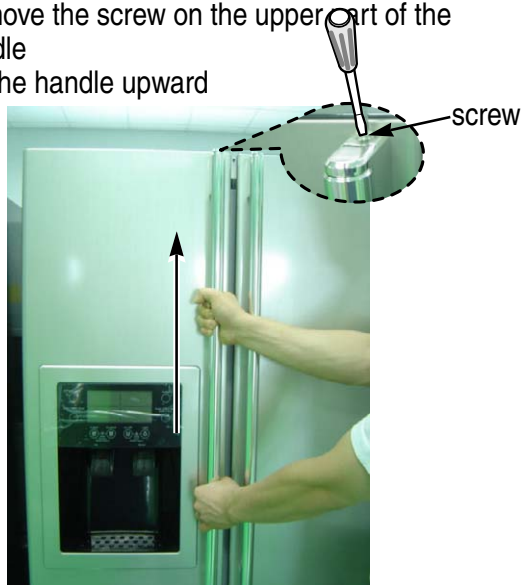

DISASSEMBLY AND REASSEMBLY

5-3) Refrigerator Compartments

Refrigerator Door Light Switch

The refrigerator has a door light switch located in the upper right corner for the refrigerator.

1. Use a small flat-blade screwdriver to unlock the locking tab and pull the switch out until you can see the wire connector.



Tempered Glass Shelf

These shelves allow the storage of larger items and easy access by pulling out.

1. Pull the shelf out as far as it goes.
2. Lift it up and remove it.



Plastic Drawers in the Refrigerator

Drawers are designed for storing fruits, vegetables, and deli items. The drawers are located in the lower portion of the refrigerator.

1. Pull out the drawer as far as it goes.
2. Tilt the drawer up and pull it out until it is removed.



Refrigerator Light

The refrigerator lights are located in the upper portion of the refrigerator.

1. At first, push both sides of the upper lamp cover → marked around the top of cold air duct, then pull out of the air duct.
2. push both sides of the bottom lamp cover, → marked on the air duct, then pull out.
3. After changing the bulb, reattach the bottom light cover, then the upper light cover.

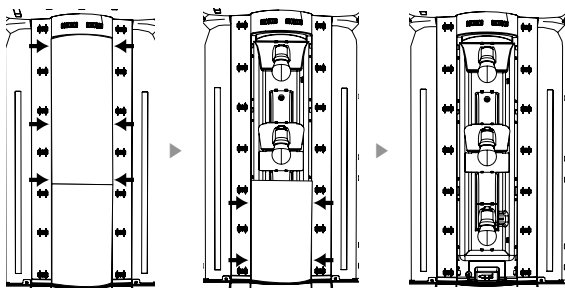

Gallon Door Bin

The door bins allow storage of perishable items.

1. Push the bin up and slide it out.



DISASSEMBLY AND REASSEMBLY

5-4) Freezer Compartments

Door Bin in Freezer

The door bins allow storage of perishable items.

1. Push the bin up and slide it out.



Plastic Drawer in Freezer

Drawers are designed for storage of meat and dried foods. The drawers are located in the lower portion of freezer.

1. Pull out the drawer as far as it goes.
2. Tilt the drawer up and pull it out until it is removed.



Freezer Door Light Switch

This switch is located in the left-hand portion of the freezer and sends a signal to the processor.

1. With a small flat-blade screwdriver, unlock the locking tabs and pull the switch out until you can see the wire connector.
2. Disconnect the wire connector and remove the switch.

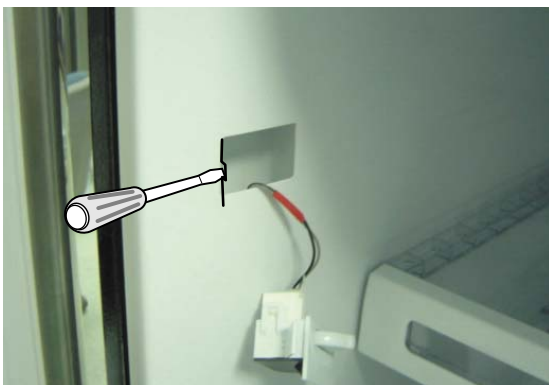

Freezer Shelf

The shelves slide out for easy access to frozen items.

1. Slide the shelf out as far as it goes.
2. Tilt it downward and pull it out of the compartment.



DISASSEMBLY AND REASSEMBLY

Ice Dispenser & Ice Maker

The ice dispenser is located in the upper portion of freezer. This assembly is to store and dispense ice made by the icemaker.

1. Lift the ice bucket up ① and slide out the ice dispenser assembly ②.



The Ice Maker is located inside of the Ice Dispenser assembly

1. Remove Ice Maker Support screw(2), and pull it out.
2. Disconnect the ice maker wire connector
3. Push the Locking Tab(1), and pull(2) the Ice Maker Kit

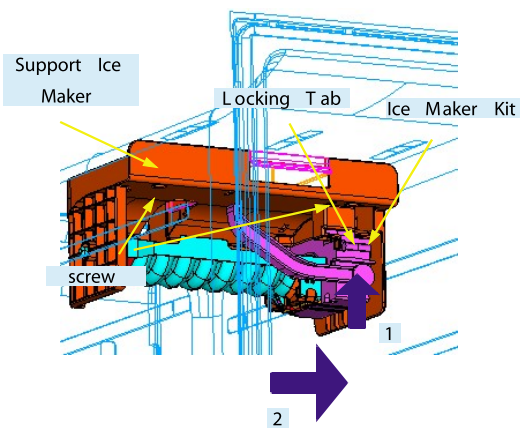

In order to assemble the IceMaker Kit.

1. Align the Gear Motor Shaft with Ice Tray hole to assemble.
2. Slide the IceMaker Kit like the arrow(1)
3. Connect the ice maker wire connector.
4. Align the tab holes with tabs(2) located in the top of liner, and slide the ice maker inward.
5. Tighten the screws (2) of the ice maker support.

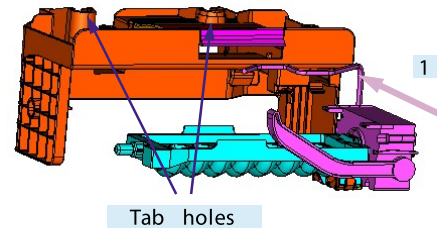
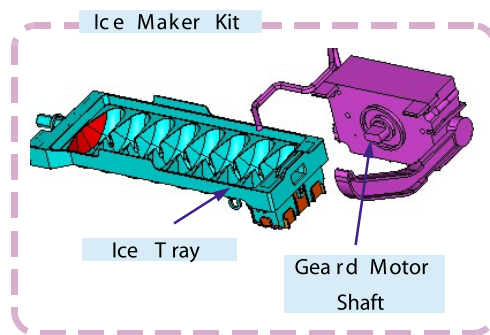

Freezer Light

The freezer light is located in the bottom of auger motor case. The light is covered with an opaque cover.

1. Remove the light cover by pressing the cover.



DISASSEMBLY AND REASSEMBLY

Auger Motor Case

This shelf is designed to support the ice maker & ice dispenser.

1. Remove the screws(2) on the side of the case
2. Slide the case out while disconnecting the wire connector.

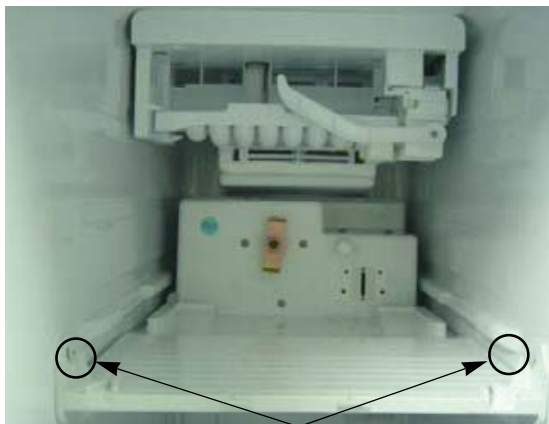

Screws

Upper Ductwork

1. Remove the screw cap and screw.
2. Slide the upper fan ductwork out while disconnecting the wire connector (Lamp and Thermistor).



DISASSEMBLY AND REASSEMBLY

PARTITION IN THE FREEZER

The Partition is located in the lower part of the freezer. Before separating the partition, take out all the shelves and cases which are above the partition.

1. Unscrew the partition(a screws).



2. Insert the flat-tip screwdriver into the center groove of the partition, and lift it up.



3. Insert the flat-tip screwdriver in the center of insulation-partition, and lift it up slightly. And then open the door in the power compartment, and lift it upward to separate.



EVAPORATOR COVER

For the disassembly of evaporator cover, water tank and partition should be disassembled first..

1. Remove the cap screws(2 pieces), and then remove other screws(4 pieces).

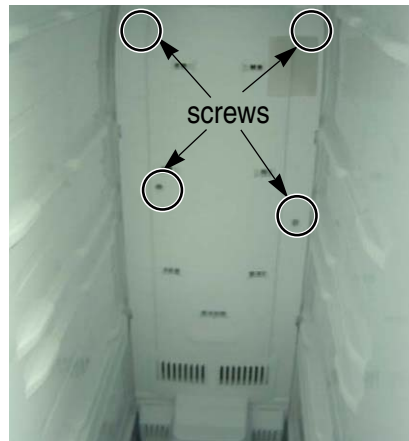

2. Pull the upper part of the evaporator cover slightly.



3. Separate the housing terminal connected to the right side of evaporator cover, and lift it up carefully using both hands.



DISASSEMBLY AND REASSEMBLY

EVAPORATOR FAN MOTOR IN ARCTIC SELECT ZONE

The Evaporator fan motor in the arctic select zone is located in the lower part of evaporator cover.

1. Remove the screws(2 pieces)attached to the Fan-Cover.



2. Separate the insulation covering the fan by removing the sponge and tape.



3. Separate the housing terminal connected to the fan, and lift up the fan.



Evaporator Fan Motor

The evaporator fan is located in the lower rear of the refrigerator. This fan circulates cold air in the refrigerator.

1. Remove the screws(4 pieces) from the four corners of fan bracket.
2. Take the fan motor assembly off.



Evaporator in Freezer

The Evaporator is located in the bottom of the freezer

1. Take off the freezer partition in.
2. Disassemble the fan motor.
3. Disconnect the wire connector (Heater, Bimetal, and Thermistor).
4. Desolder the inlet and outlet tubes.
5. Remove the evaporator.
6. Take the same steps as above to confirm the system.

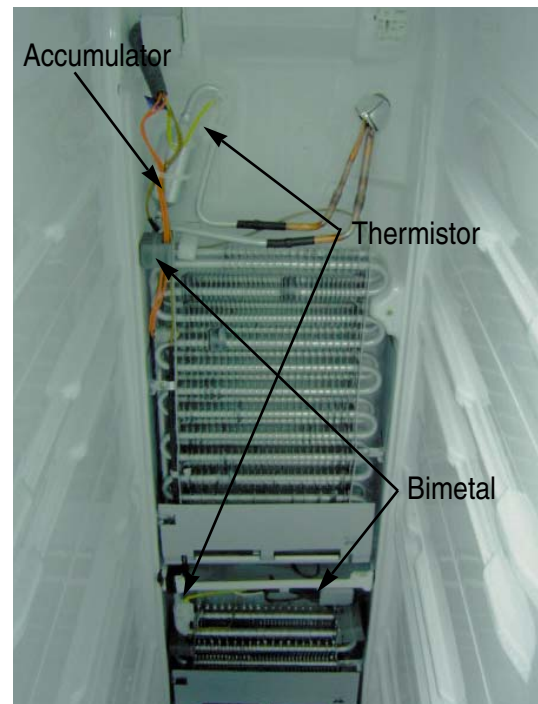

DISASSEMBLY AND REASSEMBLY

Freezer Thermistor

The refrigerator thermistor is located inside of the light cover of the refrigerator

1. Unscrew the upper left part of Ductwork, and pull the projected part of the Thermistor cover to separate.
2. Separate the housing which is inside of the Thermistor cover, and replace the sensor.

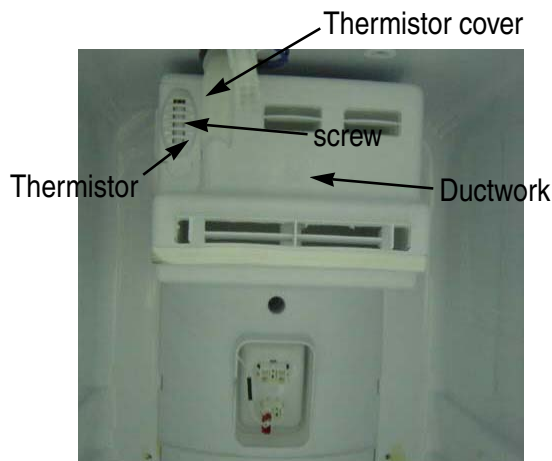

Ice-Maker Thermistor

The Ice maker thermistor is located in its bottom. The temperature signal is sent to the micro-processor.

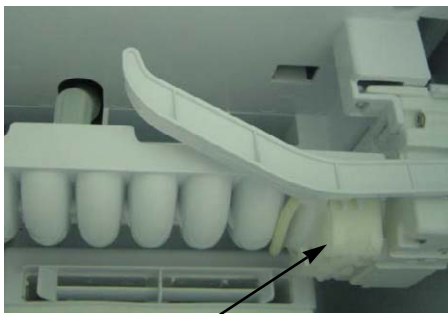

Water Tank

The water Tank is located in the lower part of the refrigerator. Before disassembling the Water Tank, take out all shelves and cases located in front of the Water Tank.

1. Unscrew the water tank(2 screws)to separate, and lift it up.



PARTITION IN THE Fridge

Partition is located in the lower part of refrigerator. For the disassembly of partition, water tank should be disassembled first.

1. Unscrew the partition. (2 screws)



2. Insert the flat-tip screwdriver into the center groove of the partition, and lift it up.

DISASSEMBLY AND REASSEMBLY



2. Pull the upper part of the evaporator cover slightly.

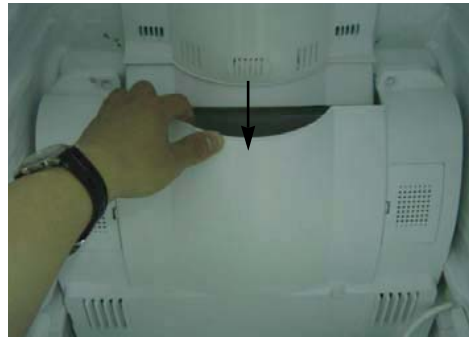

3. Insert the flat-tip screwdriver into the center of insulation-partition, and lift it up slightly to open the door in the lower compartment. then lift the insulation-partition upward to separate.



3. Separate the housing terminal connected to the right side of evaporator cover, and lift it up carefully using both hands.



evaporator cover in the Refrigerator

For the disassembly of evaporator cover, water tank and partition should be disassembled first.

1. Remove the cap screws(4 pieces), and remove other screws(4 pieces).



Evaporator Fan Motor in Refrigerator

The evaporator fan is located in the middle rear of the freezer. This fan circulates cold air in the freezer.

1. Remove screws (4 pieces) from the four corners of the fan bracket.
2. Disassemble the fan motor.



DISASSEMBLY AND REASSEMBLY

Evaporator in Fridge

The evaporator is located in the bottom of the refrigerator.

1. Take off the partition in the refrigerator.
2. Take off the evaporator cover in the refrigerator.
3. Disconnect the wire connector.(Heater and Thermistor)
4. Desolder the capillary tube and the suction line from the evaporator.
5. Remove the evaporator.
6. With a file, score the capillary tube just upstream of the soldered point. Break off the soldered section to help prevent solder from plugging the tube during soldering.
7. Place a new evaporator and braze the suction and capillary tube to the evaporator using silver solder.
8. Install a replacement dryer.
9. Evacuate and recharge the system using reasonable procedures.

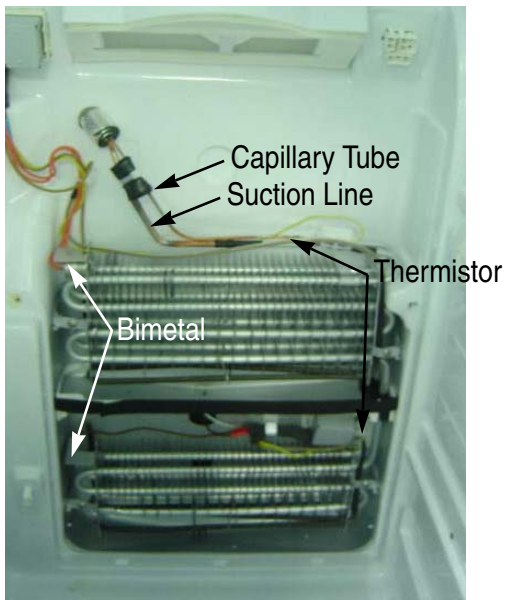

Refrigerator Thermistor

The refrigerator thermistor is located inside the refrigerator light cover

1. Put your finger into the side groove of the lamp cover, and pull the cover to separate.
2. Remove the screw in the lower part of Ductwork, and pull the Thermistor cover.
3. Separate the housing inside the of Thermistor cover, and replace the sensor.

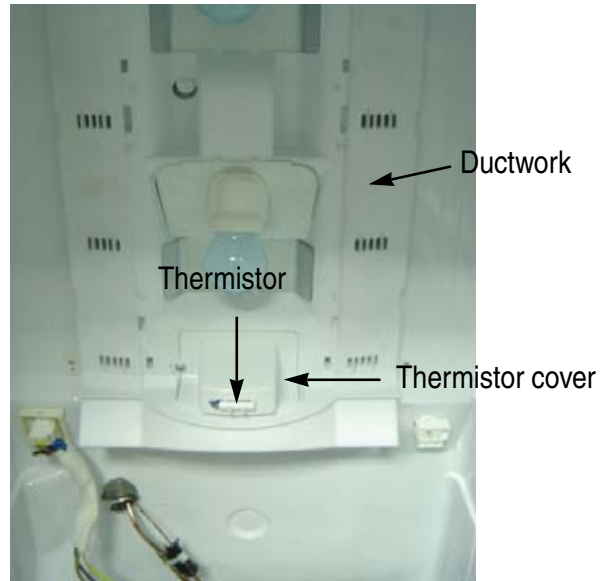

Fresh /Arctic Select Zone™ Thermistor

Fresh/Arctic Select Zone Thermistor is located in the lower part of evaporator cover

1. Unscrew both sides of the Thermistor cover.
2. Remove Thermistor cover by pulling it out.
3. Remove the tapes inside of cover, and remove the front side Insulation to replace the Thermistor.

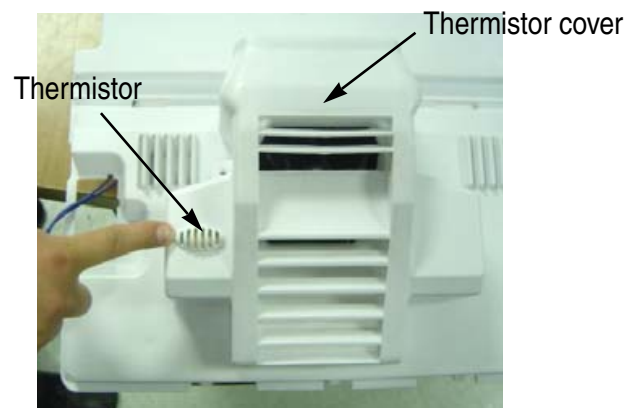

DISASSEMBLY AND REASSEMBLY

Evaporator Fan Motor in Fresh Select Zone™

The Evaporator Fan Motor in the Fresh Select Zone is located in the lower part of the cooling compartment.

1. Unscrew the fan-cover. (2 screws)



2. Separate the insulation covering the fan by removing the sponge and tape.



3. Separate the housing terminal connected to the fan, and lift up the FAN.



UPPER DUCTWORK

1. First separate the two lamp-covers which are in the upper part.



2. Unscrew the lower part and the center of the duct-work.



3. Unscrew (2 screws) the upper part of the evaporator cover to take out the duct work by pulling.



4. Separate the sensor-cover in the lower part of duct work. And then separate the housing terminals (lamp & thermistor) and pull them out using both hands.



DISASSEMBLY AND REASSEMBLY

Machine Compartment & Electric Box

1. Disconnect the power cord of the refrigerator.
2. Remove the fixing screws (8) of compressor cover.

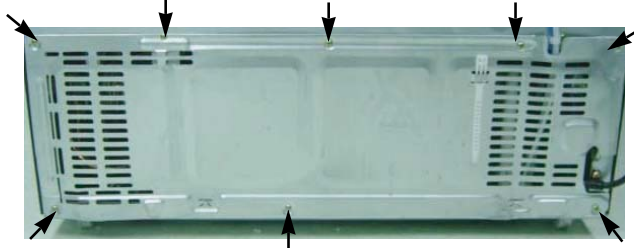

3. Slide up and take off the compressor cover to see the machine compartment.

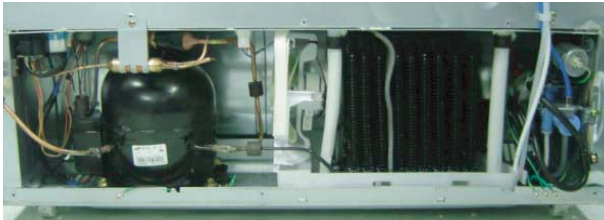

4. Unscrew the electric box cover in the rear of refrigerator with the crossed-head screwdriver.(2 screws)



5. Separate the electric box by lifting up to see pcb-main-assy.

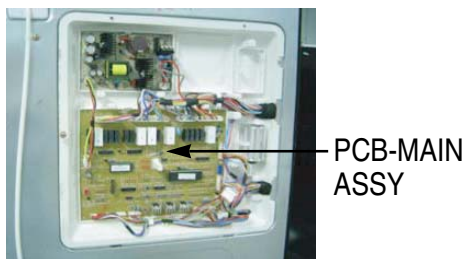

Sub-condenser

The sub-condenser is located in the machine compartment. Heat is released by the condenser fan.

1. Desolder the compressor discharge & the sub-condenser outlet.
2. Take out the sub-condenser.



Water Solenoids

When the solenoids receive a signal from the micro-processor, they supply water to the water dispenser or the ice maker.

1. Remove bracket screw (1) on cabinet bottom right sid.
2. Take the solenoid assembly out.
3. Disconnect the water tubes (3).



Condenser Fan

The condenser Fan is located in the middle of the machine compartment. It cools down the sub-condenser and the compressor.

1. Disconnect the condenser fan wire.
2. Separate the condenser fan hook attached to the drain water tray by slightly lifting and pulling the condenser fan.
3. Take the condenser fan assembly off.



DISASSEMBLY AND REASSEMBLY

REMOVING THE ARCTIC SELECT ZONE ACCESSORIES

1

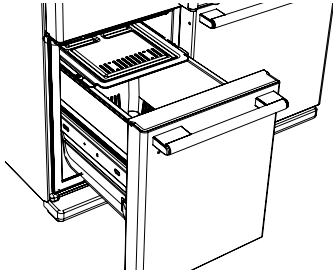

Open the Arctic Select Zone Door.
Hold the front side of cover, and pull it out.

2

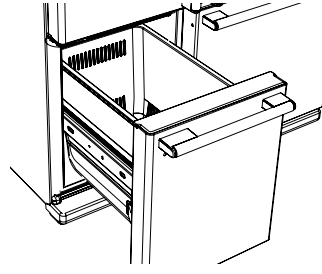

Open the door, and pull the Arctic Select Zone Door out to the end to take the basket out.

3

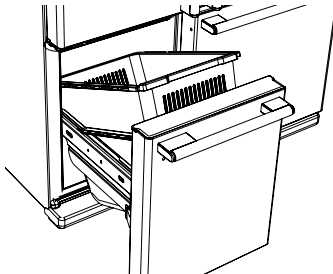

Lift the front side of basket first, and then take it out carefully.



NOTE

- Empty the basket before taking it out.

REMOVING THE FRESH SELECT ZONE ACCESSORIES

1

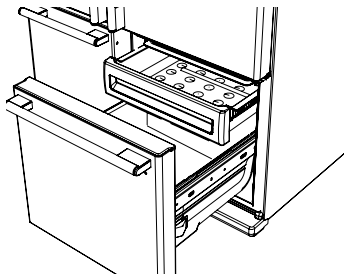

Open the Fresh Select Zone door. Hold the front side of upper drawer, and pull it out.

2

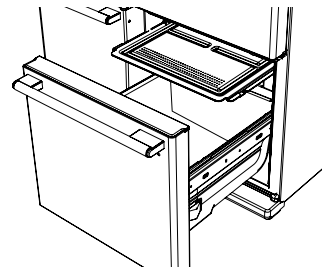

Pull the front side of upper cover out.

3

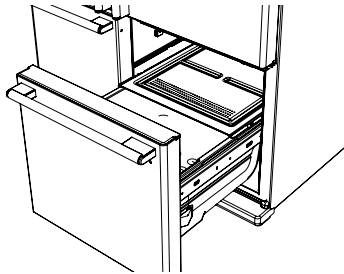

Pull the front side of cover out.

4

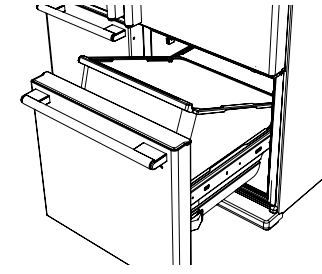

Lift the front side of basket first, and take it out carefully (using both hands).



NOTE

- Empty the basket first before taking it out.

DIAGNOSTIC

6-1) If power is not ON

Caution!

At the power of main PCB, the 115V AC and a high-voltage over DC 170V occur. Please be careful with repair and measurement

To check the main PCB, please see the "operation descriptions and references" in the manual.

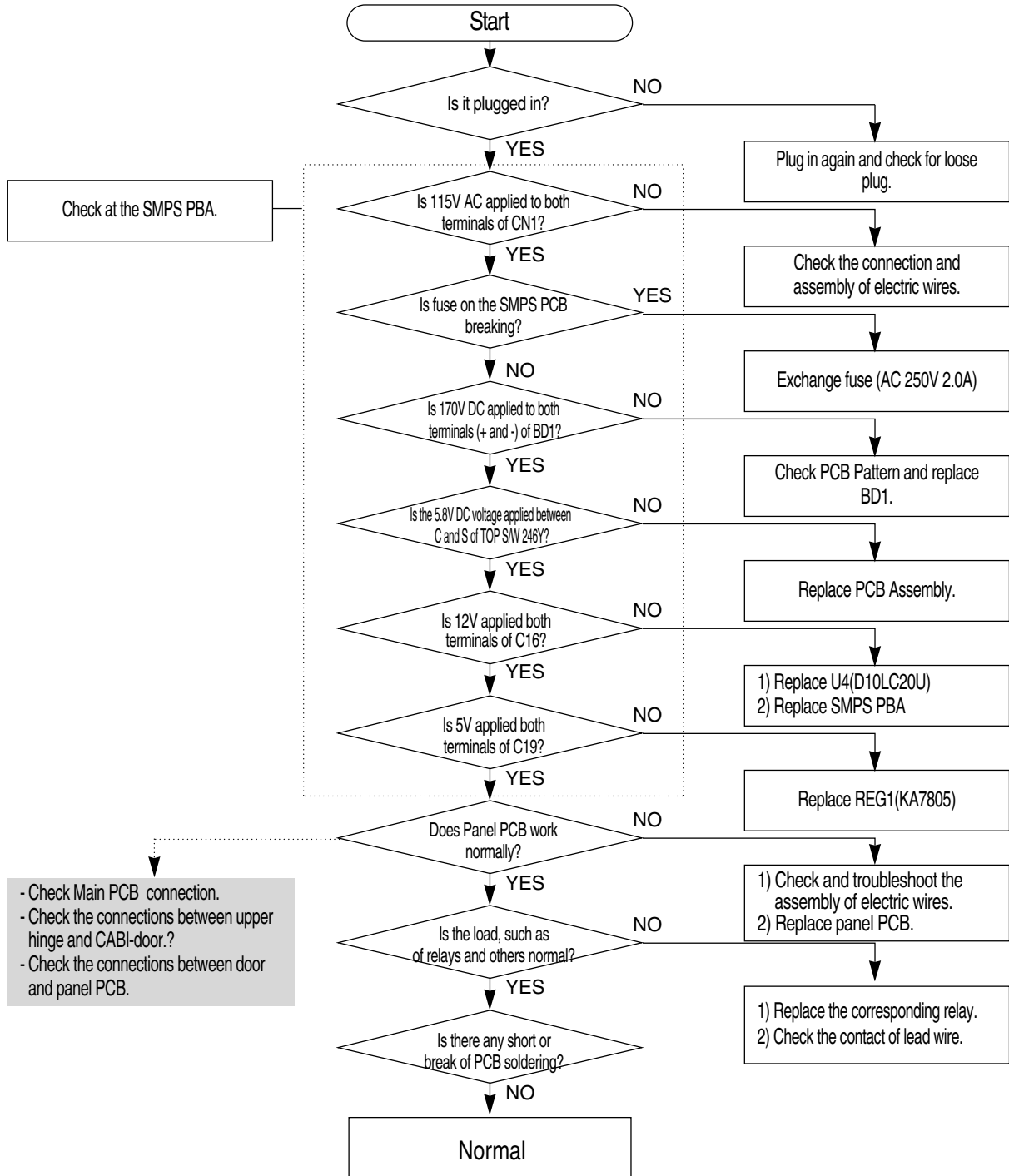

6-2) If the compressor doesn't work normally

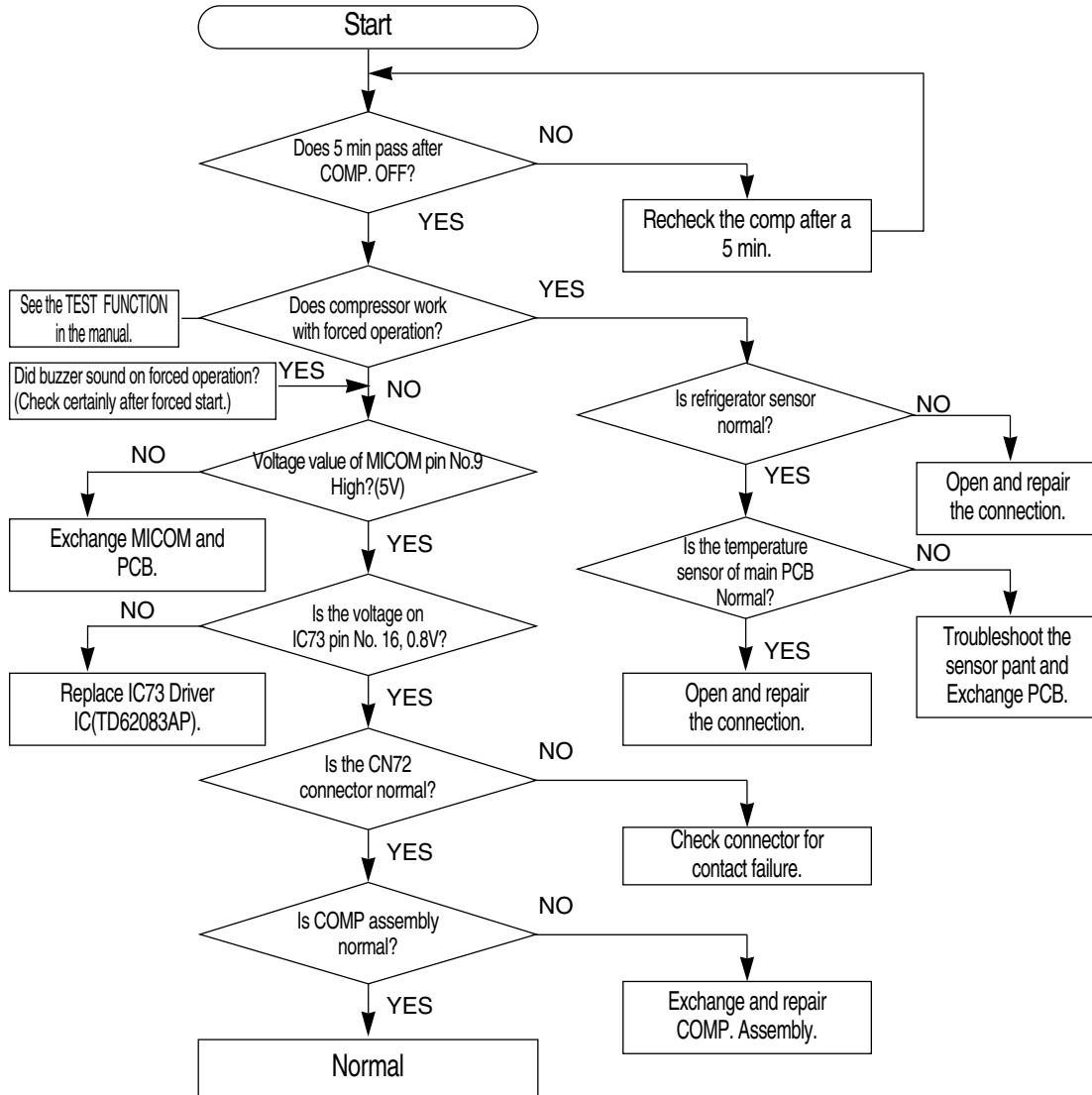

6-3) If the defrost function doesn't work

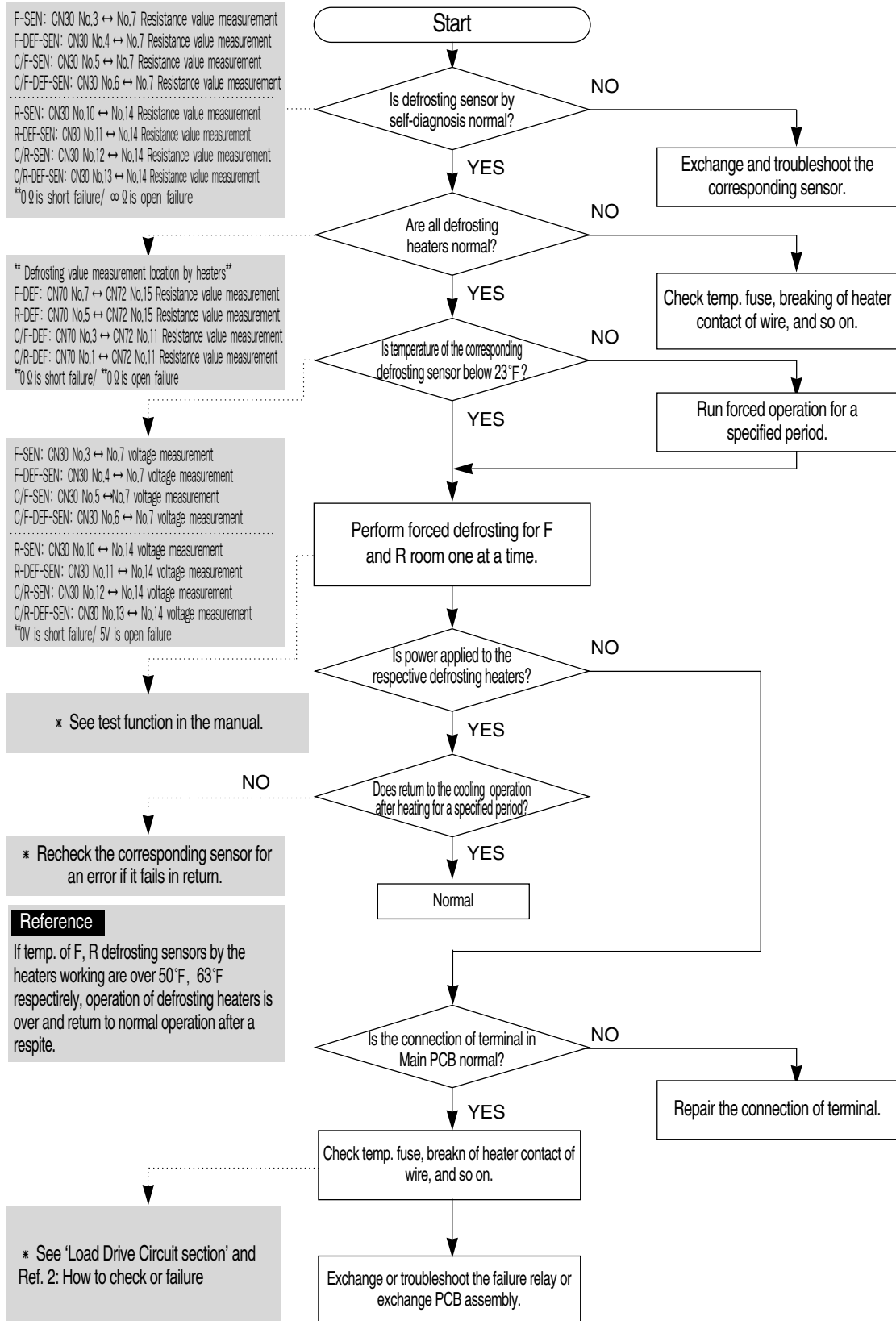

DIAGNOSTIC

6-4) If there is a trouble with self-diagnosis(sensor failure)

- Error in sensor can be seen on the front display of refrigerator. If sensor failure is found when power is initially impressed to refrigerator, the product will not work, and display is repeatedly blinking in the trouble occurred sensor.
- Even if sensor has failure during the operation refrigerator will not stop working but can't run the normal cooling operation because of being operated in the Emergency Operation mode. Thus, be sure to follow instructions in the manual when you make self-diagnosis.

1) If the ambient temperature sensor has trouble

This model has an ambient temperature sensing operation in the panel PCB. The sensed information is communicated between main PCB and panel PCB. So you must review the causes of failure without disassembling the panel PCB. If it displays the sensor ERROR in the parts related to the ambient temperature sensor on the panel, it is understood that the communication with MAIN PCB is normal. In this case, check the sensor unit, missing wires and short & breaking or wires, etc.

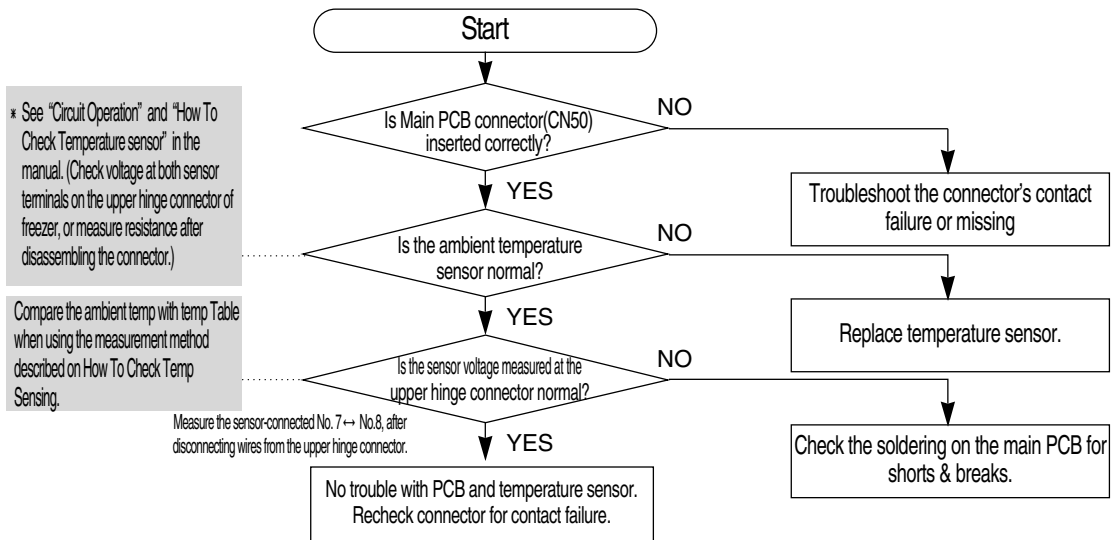

2) If the temperature sensor of Refrigerator has trouble (Apply to the other sensor checks.)

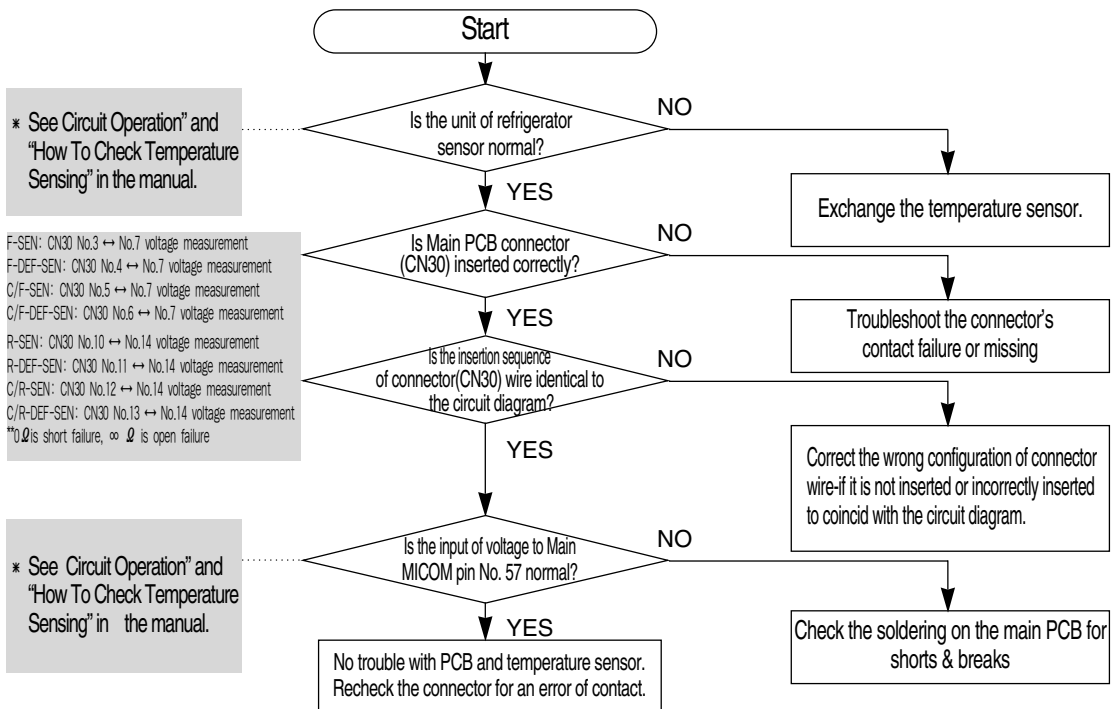

6-5) Alarm Sounds continuously(related to the buzzer)

1) If “Ding-Dong” sounds continuously

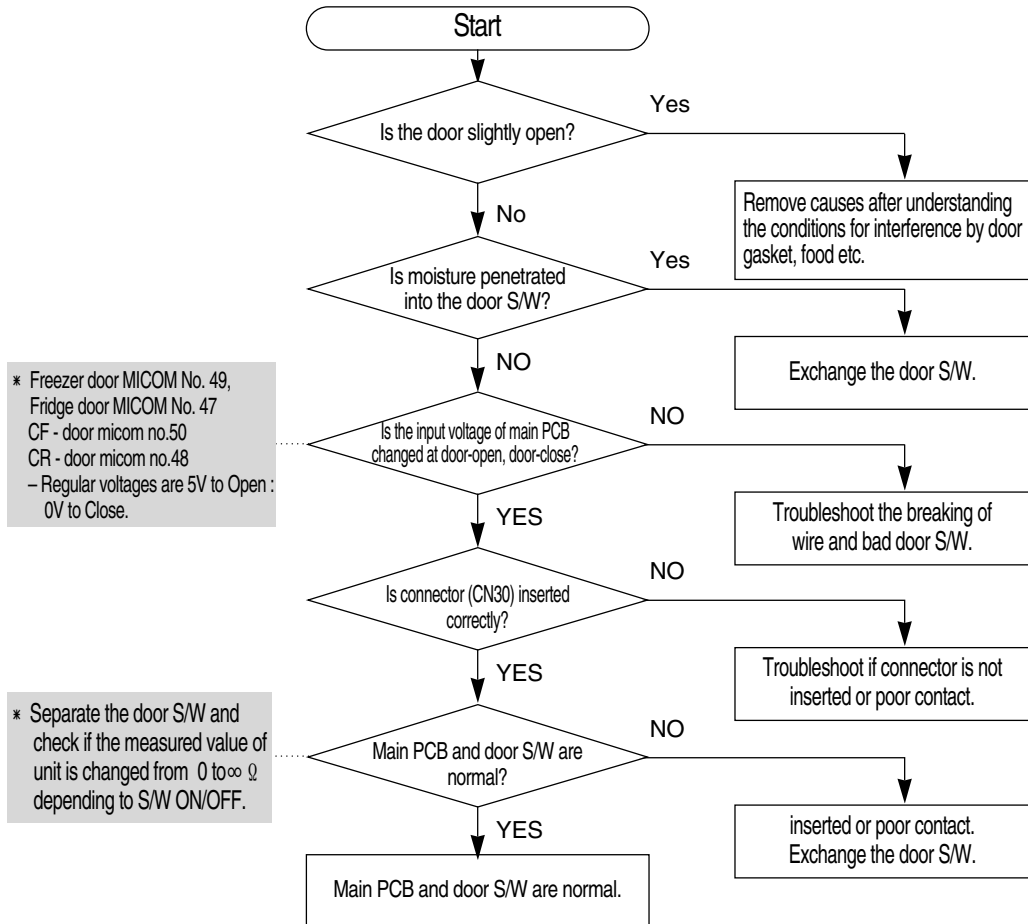

2) If “Beep” sounds continuously

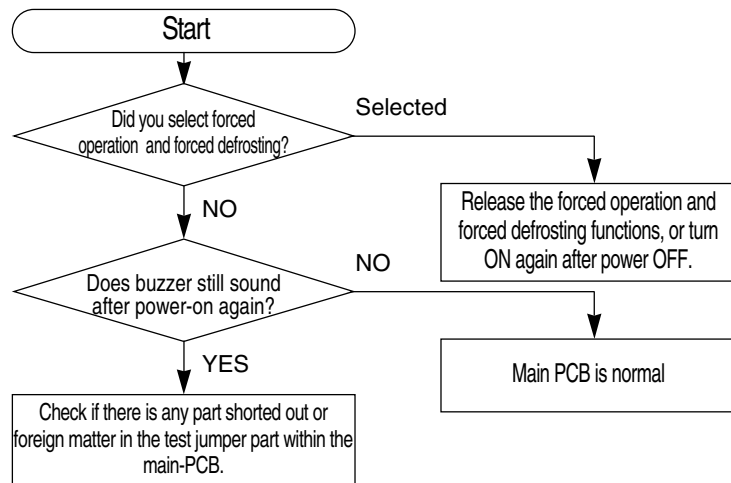

DIAGNOSTIC

3) If the buzzer doesn't sound

This model is equipped with the buzzer on the Panel PCB. If buzzer doesn't sound in case of button operation, forced operation or door opening, separate the panel PCB first to check if buzzer is broken or there are any soldering failures.

It is not easy to troubleshoot it as the Panel PCB is made with SMD parts. You are strongly required to replace the assembly with a new one, unless the failure is not serious, for example S/W pressing failure, surface part come-off, etc.

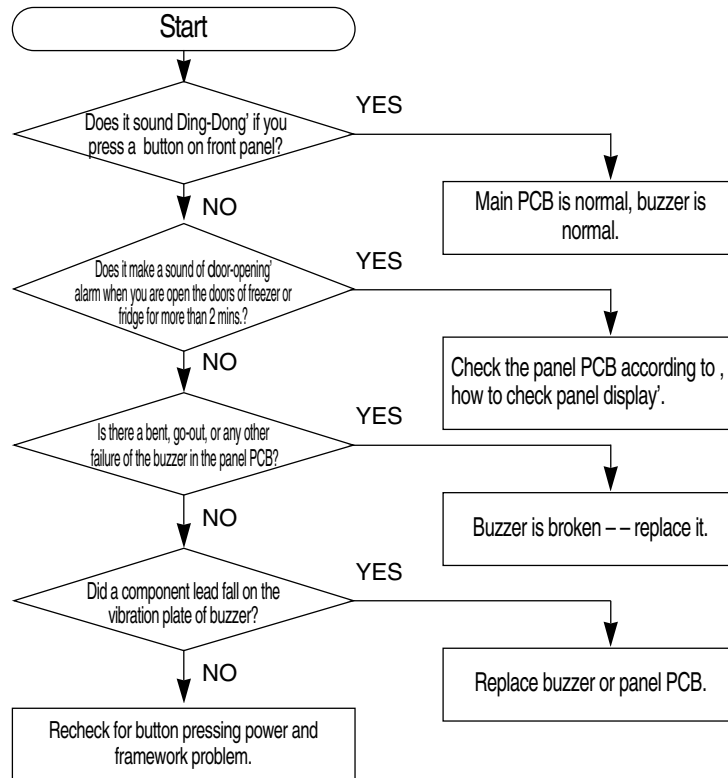

DIAGNOSTIC

6-6) If the panel PCB is not working normally:

1) Where all lights of the panel PCB are disabled, or only some lamps are disabled.

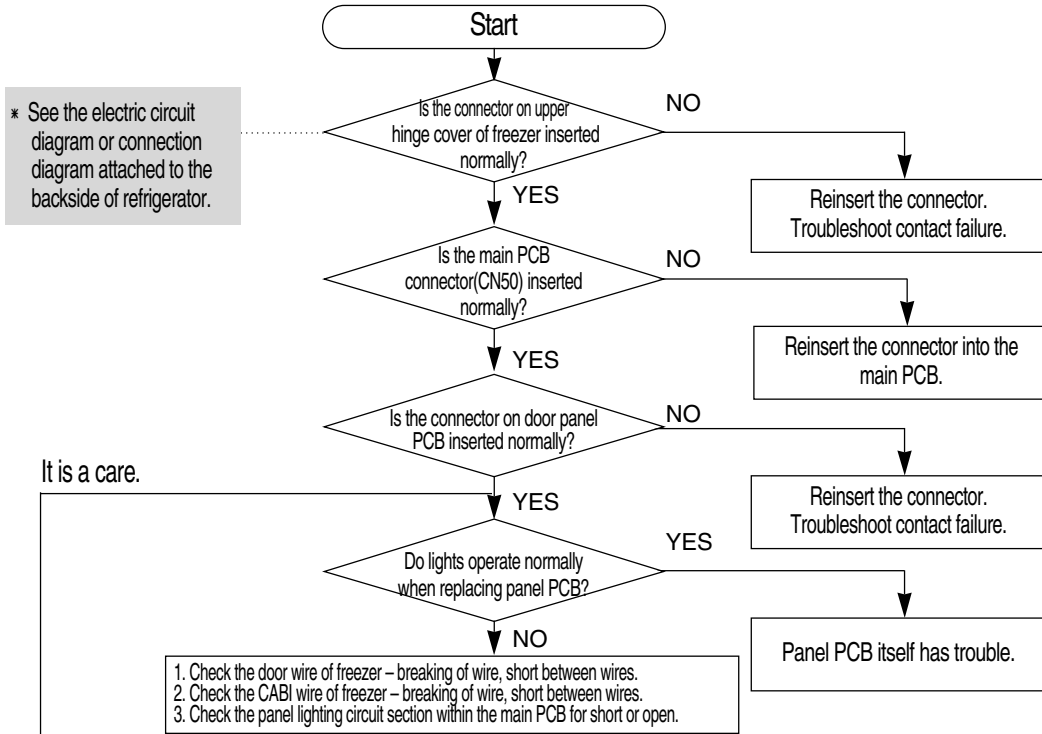

It is a care.

2) Where the Panel PCB key isn't selected:

- The basic check way : Please follow the basic check method, and then if it doesn't work proceed as follows.

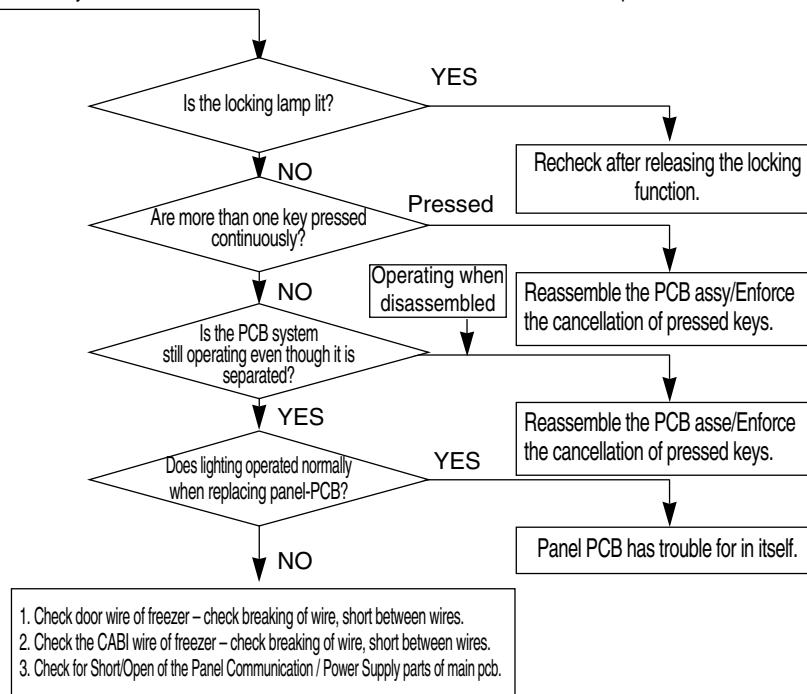

DIAGNOSTIC

6-7) If fan motor doesn't working normally.

- This refrigerator uses a BLDC FAN motor and this motor is driven by 8 ~12V DC.
- Under the normal condition of COMP ON, it is operated together with F-FAN motor. F-Fan motor may not work depending on the conditions. If the door is opened and closed once at a high ambient temperature, the BLDC motor would be operated after 1 minute or delayed longer. Therefore, you are advised not to take it for an error.

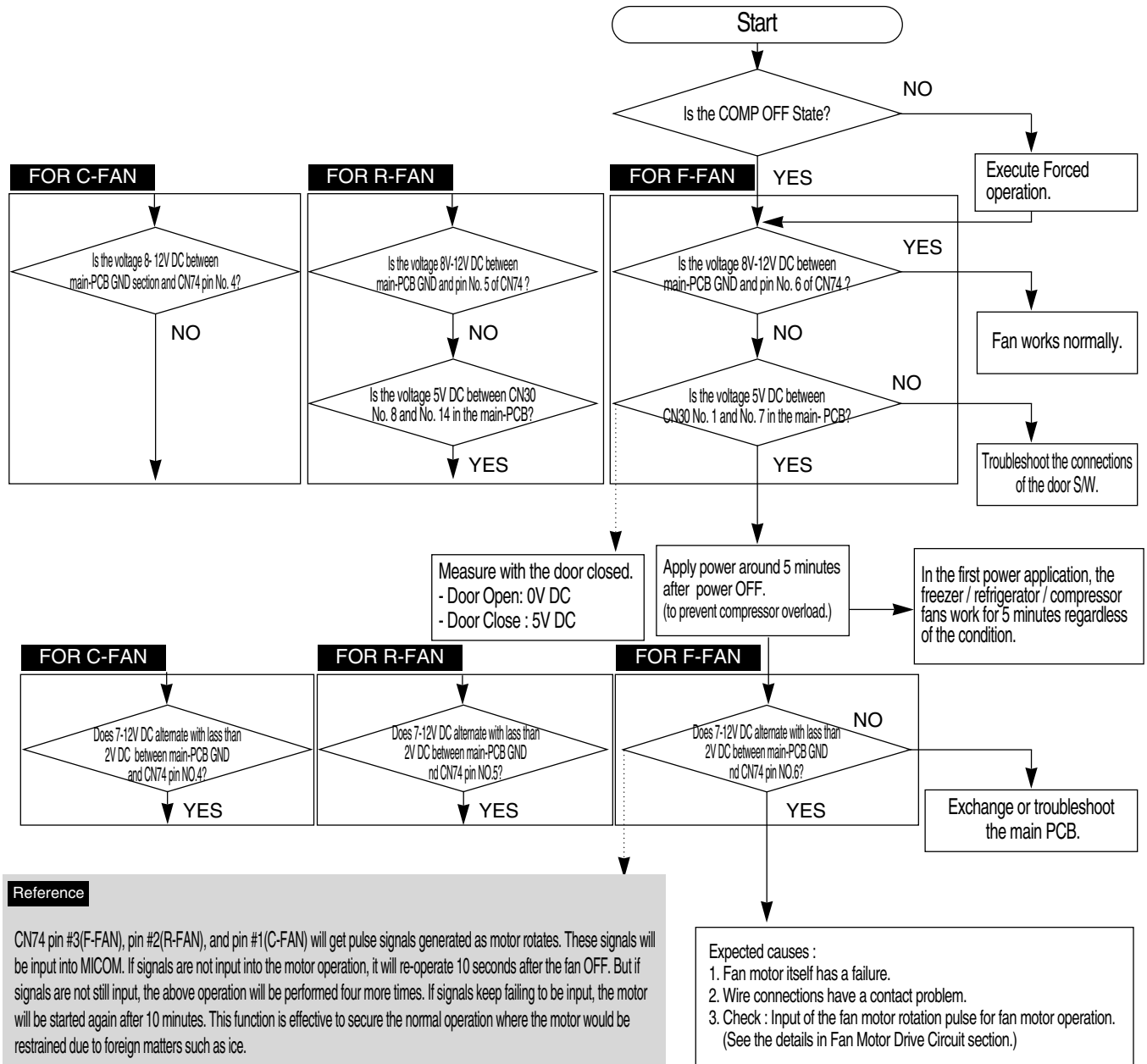

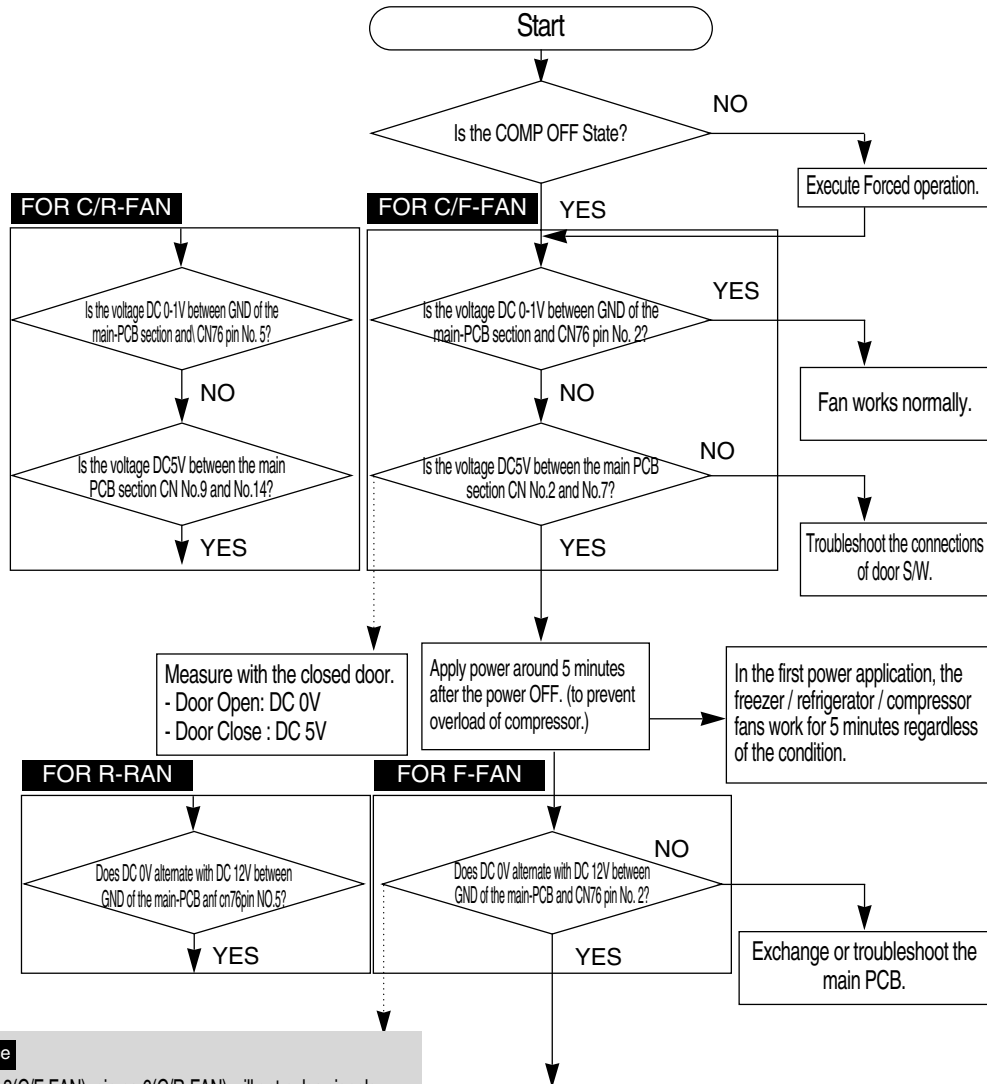

Reference

CN76 No. 3(C/F-FAN), pin no.6(C/R-FAN) will get pulse signals which is generated when the motor rotates. These signals will be inputted into MICOM. Unless signals are not inputted in the motor operation, it will be ON 10 seconds after the fan OFF. But if signals are not still entered, the above operation will be performed four times more. Without signals entered continuously, the motor will get restarted after 10 minutes. This function is effective to secure normal operation where the motor would be restrained due to foreign matters such as ice. Ref

DIAGNOSTIC

6-9) If Ice Cubed or/and Ice Crushed don't work normally

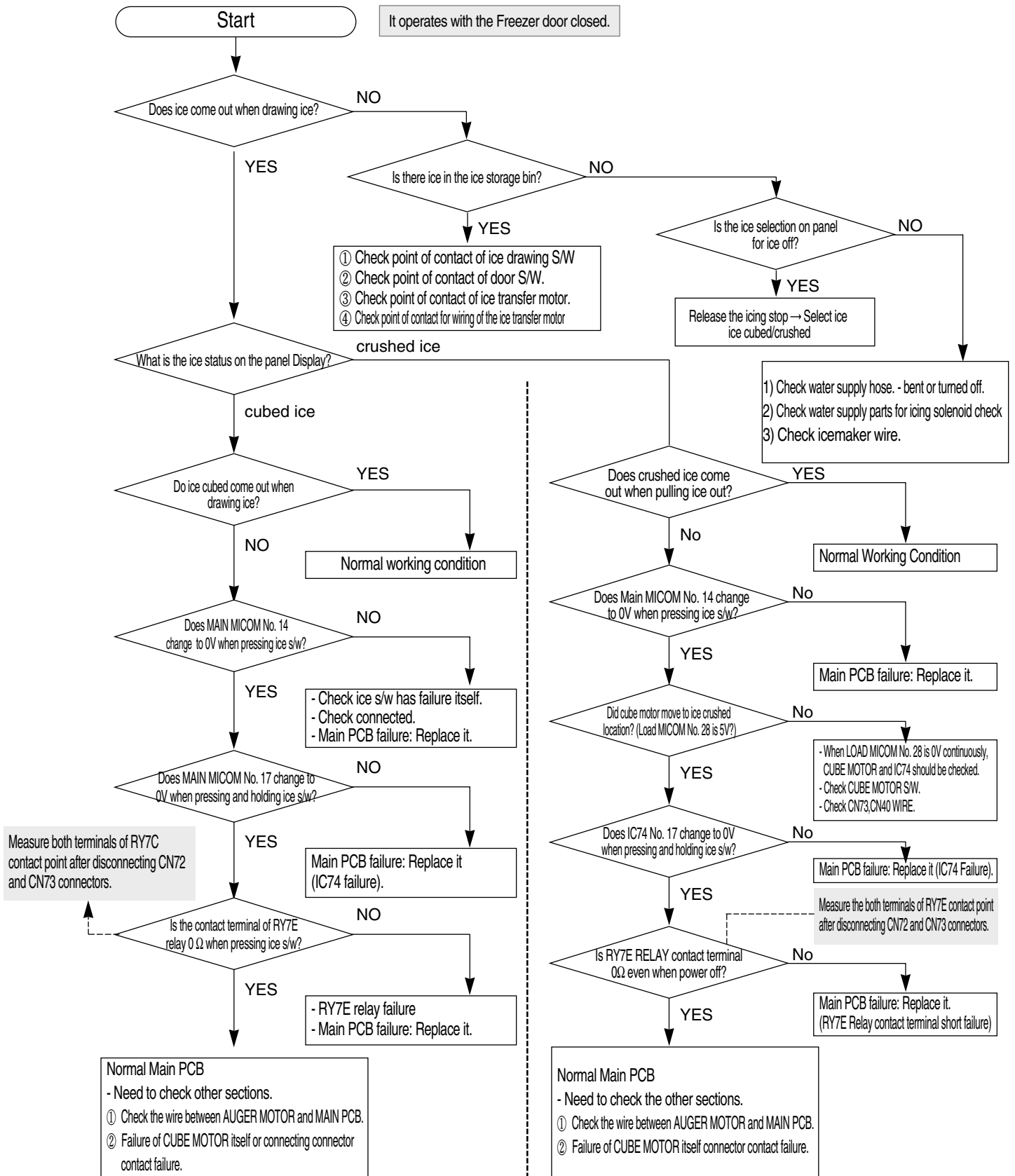

DIAGNOSTIC

6-8) If Indoor Lamp of Freezer/Refrigerator doesn't light

⚠ Caution!

1. When replacing the indoor lamp of freezer or refrigerator, please turn the power OFF to avoid an electric shock.
2. Please be sure to avoid a burn by the excessive heating of incandescent light bulb.

* An example of F-Room Lamp is presented as follows.
And you may apply the same principle and method to the other indoor lamps.

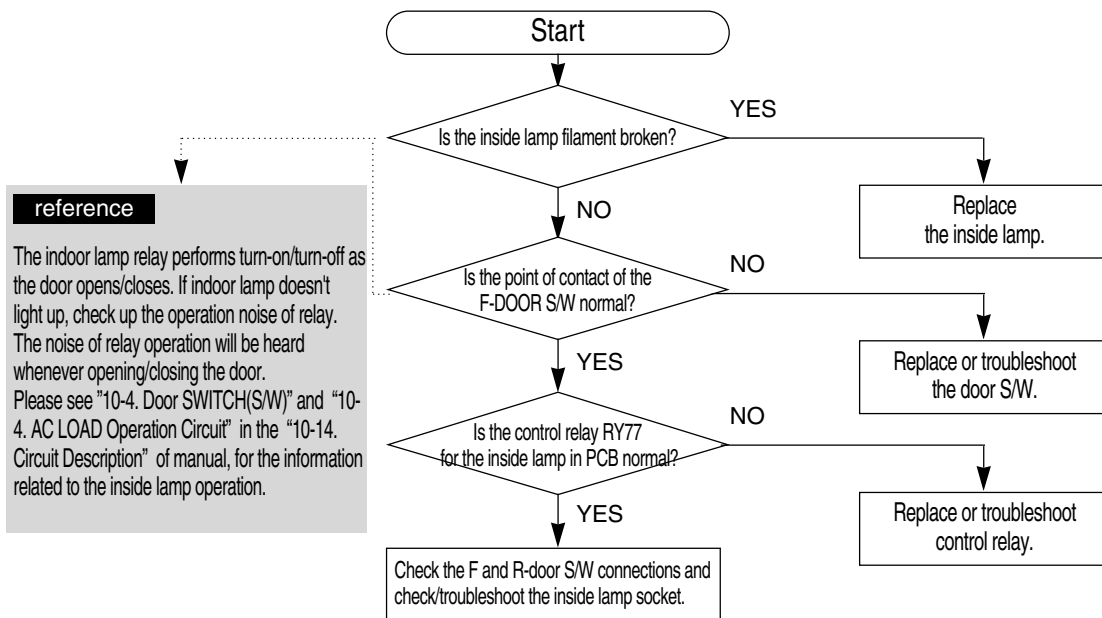

Reference

If the door is opened, contact of door S/W is opened and voltage of 5V is applied to MICOM to finally sense the Openness. If 5V is sensed more than 2 minutes afterwards, Door-Open alarm will sound 'ding-dong' for 10 seconds every 1 minute. For that reason, if the door S/W has a failure, refrigerator makes 'ding-dong' sound every 1 minute. Please take note of it during service.

DIAGNOSTIC

6-10) If Water Drawer doesn't work normally

Preliminary Check

1. Stop water supply before disassembling or assembling because water is directly supplied to the water valve.
2. Keep in mind to avoid shock hazard during disassembly because power is always present on one side of wire.

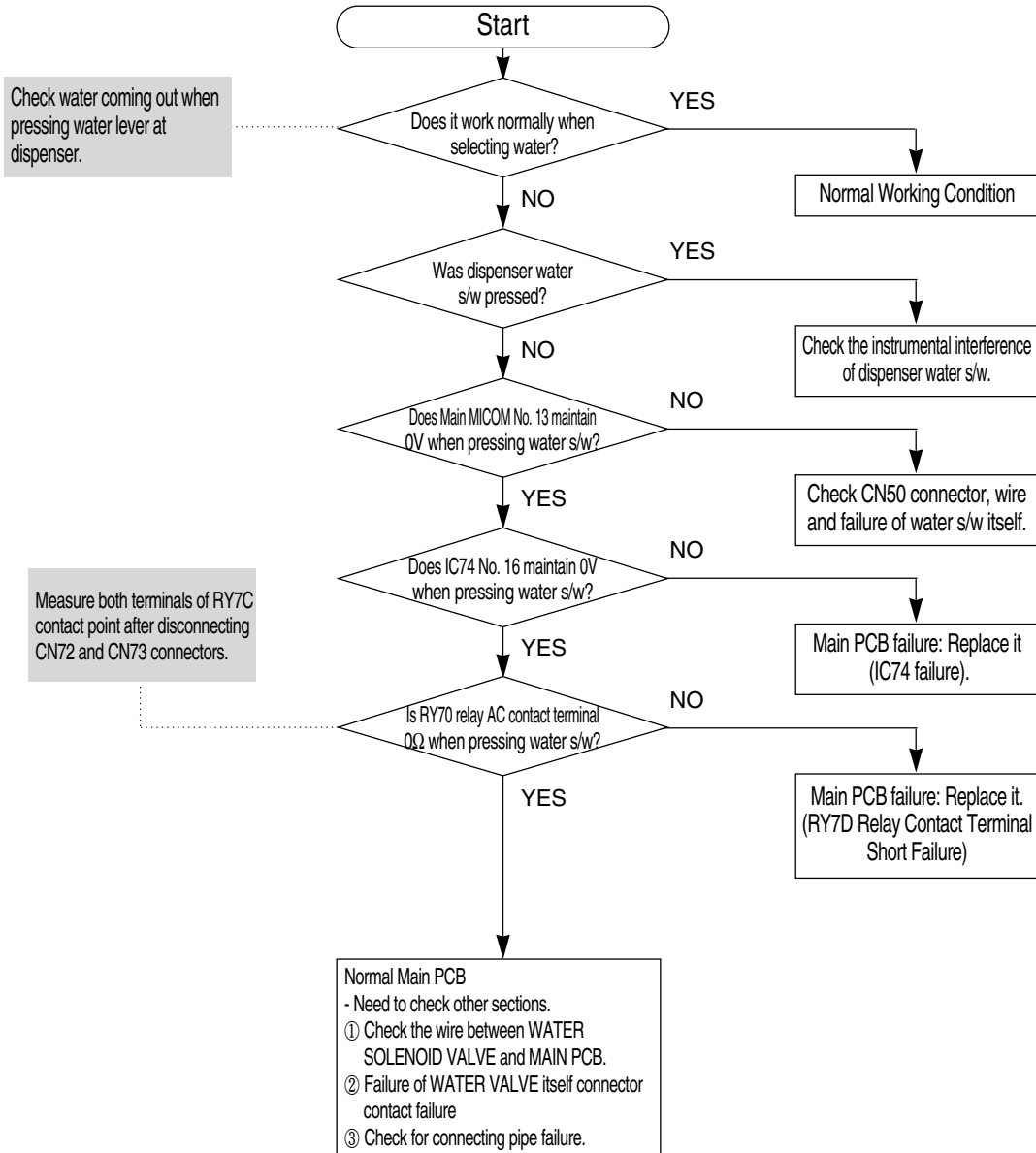

DIAGNOSTIC

6-11) If Dispenser LED Lamp doesn't light

Caution

1. Dispenser LED Lamp is working with 12V DC.(=Dispenser LED Lamp has 12V DC power supply.) Anyone without approval or other than the qualified engineer is prohibited to perform the repair or disassembling work due to the danger of high voltage DC current.
2. To replace LED Lamp, the dispenser cover should be disassembled. Anyone without approval or other than the qualified engineer is prohibited to perform the repair or disassembling work due to the danger of AC voltage applied parts in the dispenser.

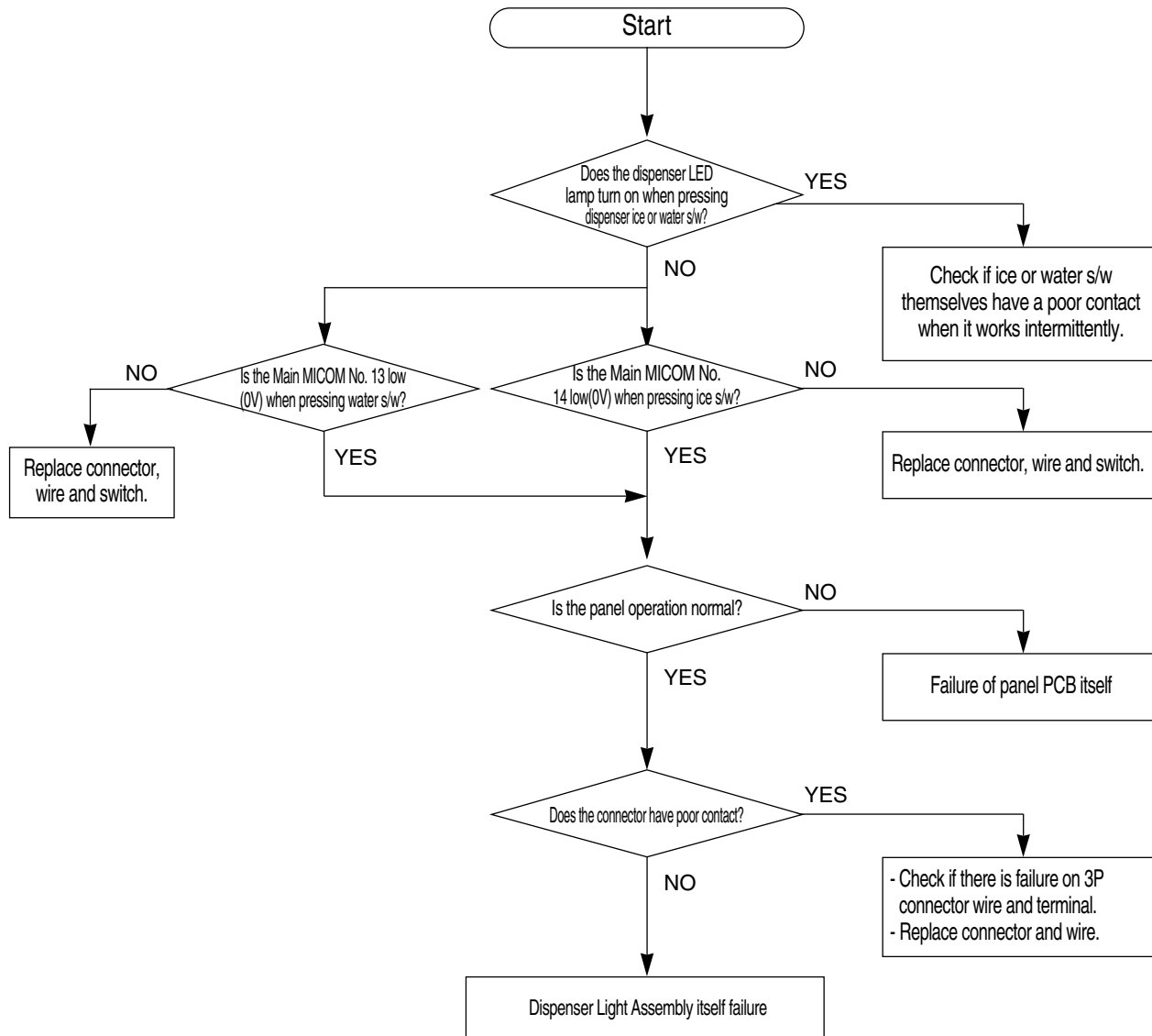

9. WIRING DIAGRAM

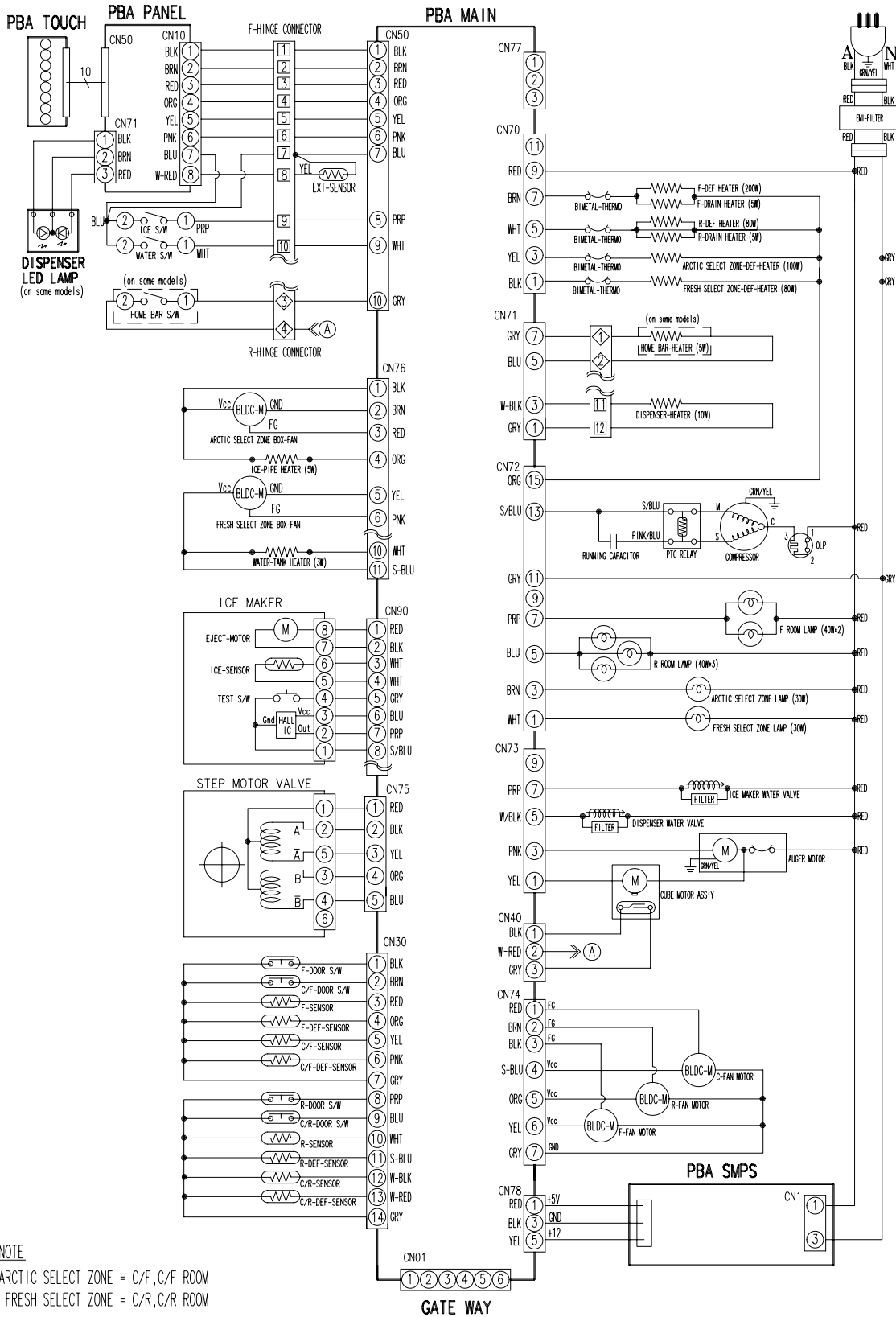

PCB DIAGRAM

10-2) CONNECTOR ARRANGEMENT (Main Board)

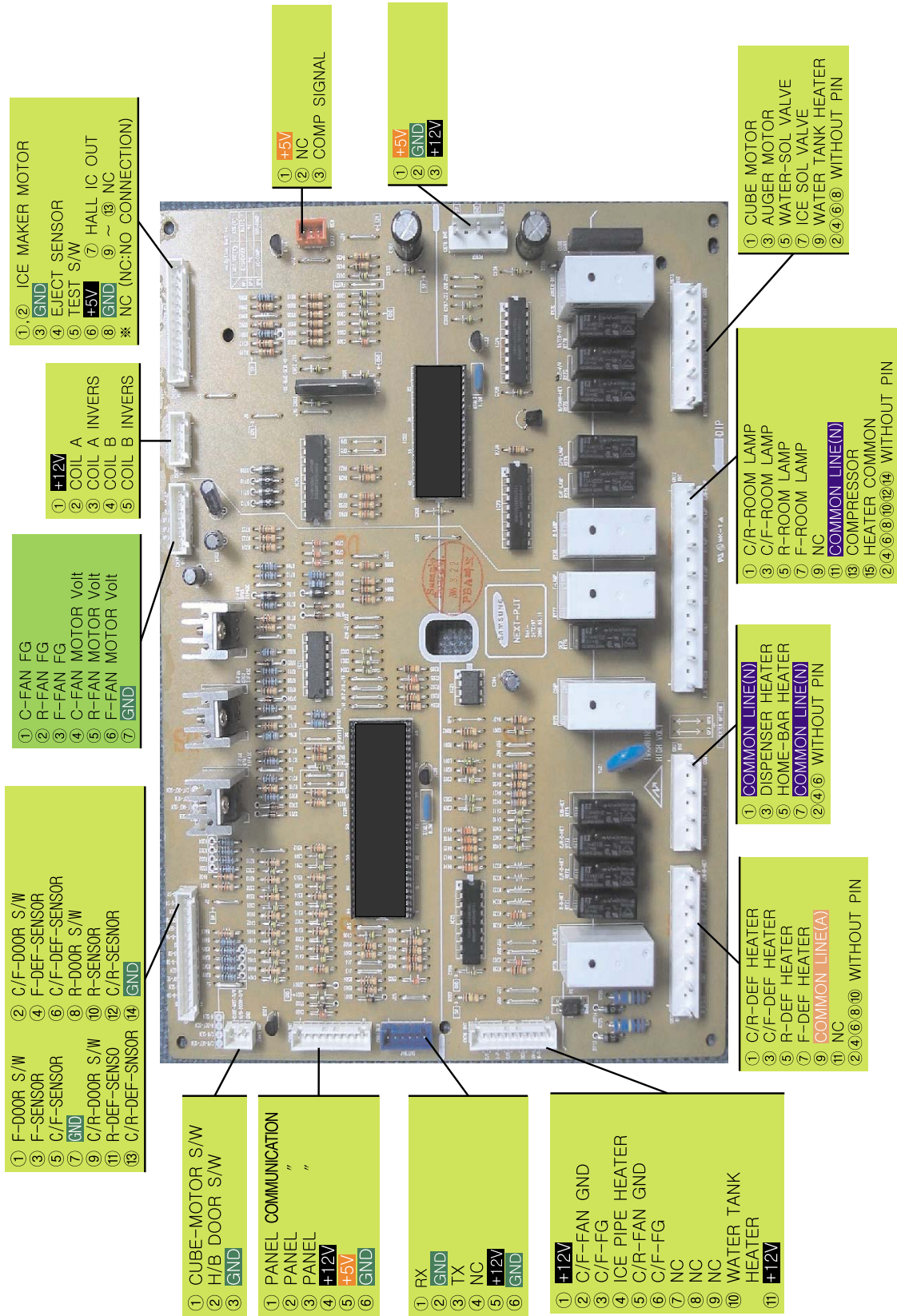

CIRCUIT(SCHEMATIC) DIAGRAM

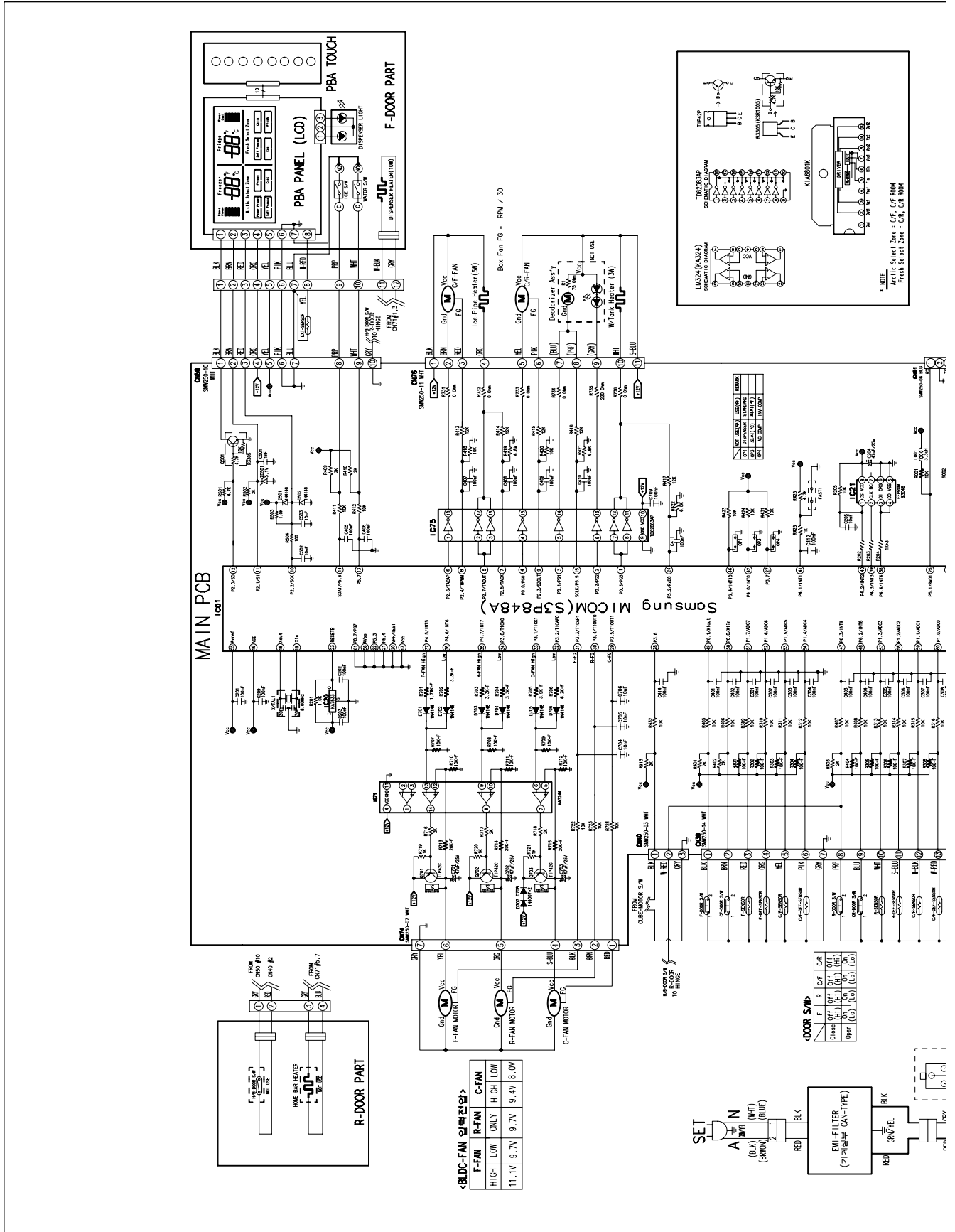

Circuit Descriptions

10-3) CONN ECTOR ARRANGEMENT (SMP S Board)



- ① COMMON LINE(A)
- ③ COMMON LINE(N)

- ① +5V (RED)
- ③ GND (BLK)
- ⑤ +12V (YEL)

Circuit Descriptions

12-1) POWER BUS



AC INPUT CONNECTOR

— 5V
— GND
— 12V

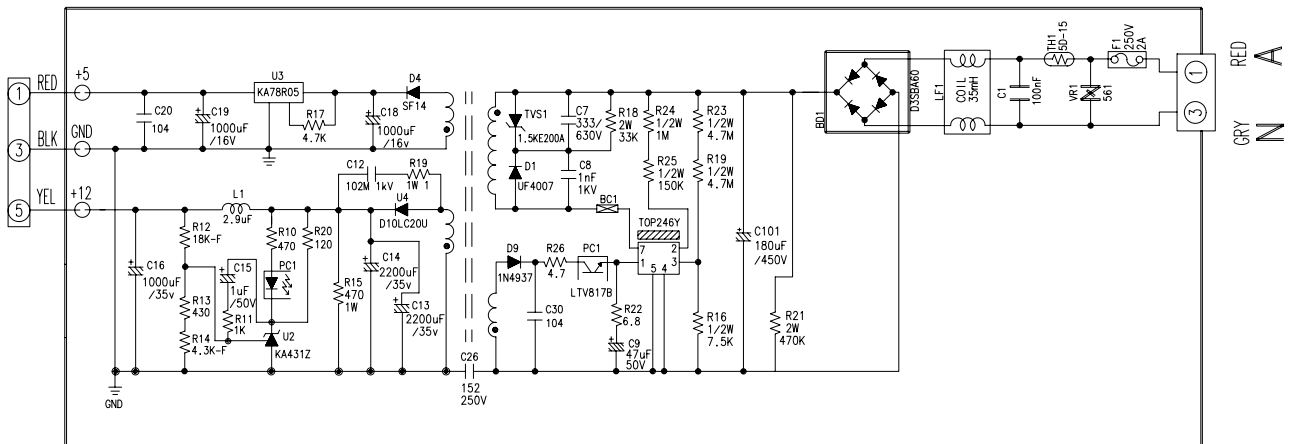

This POWER BUS, and SMPS (Switch Mode Power Supply), is an improved efficiency power-conversion circuit for converting AC input voltage to high voltage DC. However, a consistent attention should be paid to the POWER BUS because 115V AC and 170V DC may be generated. The voltage input has AC applied into BD1 (Rectifier Circuit) through FUSE (F1) and LF1, and smoothes the rectified voltage through C101 (180uF/450V). As a result, DC voltage is applied into the SMPS TRANS. At the same time, the rectified DC voltage is applied into No. 2 of U5 (TOP246Y)08 through R24 and R25, and starts initial IC operation. With the role of SNUBBER Circuit (D1, R18, C7, TVS1, C8), also controls the switching wave-formed P-P voltage to protect U5 IC. R21 (2W/470K) is the parts that special regard must be paid to the safety against potential electric shock during SVC, which is charged with power ON and discharging electricity with power OFF. When the initial operating voltage is applied into U5 No. 2 PIN, the U5 IC starts high speed (130KHz) switching operation. And then the input voltage is applied into NP1 (primary winding) of TRANS first, and a voltage proportional to

CIRCUIT DESCRIPTIONS

Temp.(°F)	Temp.(°C)	Resistance(Ω)	Voltage(V)
-43.6	-42	98.9	4.54
-41.8	-41	93.7	4.52
-40.0	-40	88.9	4.49
-38.2	-39	84.2	4.47
-36.4	-38	79.8	4.44
-34.6	-37	75.7	4.42
-32.8	-36	71.8	4.39
-31.0	-35	68.2	4.36
-29.2	-34	64.7	4.33
-27.4	-33	61.5	4.30
-25.6	-32	58.4	4.27
-23.8	-31	55.6	4.24
-22.0	-30	52.8	4.20
-20.2	-29	50.2	4.17
-18.4	-28	47.8	4.13
16.6	-27	45.5	4.10
-14.8	-26	43.3	4.06
-13.0	-25	41.2	4.02
-11.2	-24	39.2	3.99
-9.4	-23	37.4	3.95
-7.6	-22	35.7	3.91
-5.8	-21	34.0	3.86
-4.0	-20	32.4	3.82
-2.2	-19	30.9	3.78
-0.4	-18	29.5	3.73
1.4	-17	28.1	3.69
3.2	-16	26.9	3.64
5.0	-15	25.7	3.60
6.8	-14	24.5	3.55
8.6	-13	23.4	3.50
10.4	-12	22.4	3.46

Temp.(°F)	Temp.(°C)	Resistance(Ω)	Voltage(V)
12.2	-11	21.4	3.41
14.0	-10	20.5	3.36
15.8	-9	19.6	3.31
17.6	-8	18.7	3.26
19.4	-7	17.9	3.21
21.2	-6	17.2	3.16
23.0	-5	16.4	3.11
24.8	-4	15.7	3.06
26.6	-3	15.1	3.01
28.4	-2	14.5	2.96
30.2	-1	13.9	2.90
32.0	0	13.3	2.85
33.8	1	12.7	2.80
35.6	2	12.2	2.75
37.4	3	11.7	2.70
39.2	4	11.3	2.65
41.0	5	10.8	2.60
42.8	6	10.4	2.55
44.6	7	10.0	2.50
46.4	8	9.6	2.45
48.2	9	9.2	2.40
50.0	10	8.8	2.35
51.8	11	8.5	2.30
53.6	12	8.2	2.25
55.4	13	7.9	2.20
57.2	14	7.6	2.15
59.0	15	7.3	2.10
60.8	16	7.0	2.06
62.6	17	6.7	2.01
64.4	18	6.5	1.97
66.2	19	6.2	1.92

Temp.(°F)	Temp.(°C)	Resistance(Ω)	Voltage(V)
68.0	20	6.01	1.88
69.8	21	5.79	1.83
71.6	22	5.58	1.79
73.4	23	5.38	1.75
75.2	24	5.19	1.71
77.0	25	5.00	1.67
78.8	26	4.82	1.63
80.6	27	4.65	1.59
82.4	28	4.49	1.55
84.2	29	4.33	1.51
86.0	30	4.18	1.47
87.8	31	4.03	1.44
89.6	32	3.89	1.40
91.4	33	3.76	1.37
93.2	34	3.63	1.33
95.0	35	3.51	1.30
96.8	36	3.39	1.27
98.6	37	3.28	1.23
100.4	38	3.17	1.20
102.2	39	3.06	1.17
104.0	40	2.96	1.14
105.8	41	2.86	1.11
107.6	42	2.77	1.09
109.4	43	2.68	1.06
111.2	44	2.59	1.03
113.0	45	2.51	1.00
114.8	46	2.43	0.98
116.6	47	2.35	0.95
118.4	48	2.28	0.93
120.2	49	2.21	0.90

CIRCUIT DESCRIPTIONS

- 1) As shown in the Figure, C/F, C/R FAN are connected to the CN75 connector, and FAN MOTOR consists of ND, VCC, FG.
- 2) If you intend to operate the C/F-FAN or C/R-FAN according to a certain condition in the MAIN PCB, which controls the refrigerator, follow the instructions below.
- 3) For example, to operate C/F-FAN, a 5V voltage comes out of MICOM #6 first. Then, the 5V voltage is input to IC75 #1 PIN, and the #18 PIN has a changed electric potential from 0V to GND.
- 4) 12V is connected to CN76 ①, and input to C/F-FAN Vcc. FAN MOTOR GND is connected to IC75 #18 PIN through CN76 ②.
- 5) Thus, with the IC75 #18 PIN changed to GND by the signal from MICOM#6 PIN, the FAN MOTOR will be operated in the order 12V → CN76 ① → C/F①-FAN Vcc → C/F-FAN GND → CN76 ② → **IC75 #18 PIN** → GND.
- 6) Here, with normal operation of the FAN MOTOR, a square wave is generated in MOTOR FG, and this wave is input as follows, MOTOR FG → CN76 ③ → R413 → MICOM #8.
- 7) Using this FG signal, it can be determined whether the FAN MOTOR is operating normally, and in case of FG signal errors, FAN motor errors are detected to use as refrigerator error data.
- 8) When the MICOM #6 signal changes to 0V again, IC75 # 1 PIN is OFF, and IC75 #18 PIN is OFF. Thus, current cannot flow, and the FAN MOTOR will stop..

		MICOM STATUS	IC75 INPUT	IC75 OUTPUT
C/F-FAN	ON	#6 5V	#1 5V	#18 GND(0.8V)
	OFF	#6 0V	#1 0V	#18 11~12V
C/R-FAN	ON	#4 5V	#4 5V	#15 GND(0.8V)
	OFF	#4 0V	#4 0V	#15 11~12V



The principle of operation is equally applied to the C/F and C/R FAN, and the BOX FAN uses the same specification.

BOX FAN SPEC
12V / 0.2A

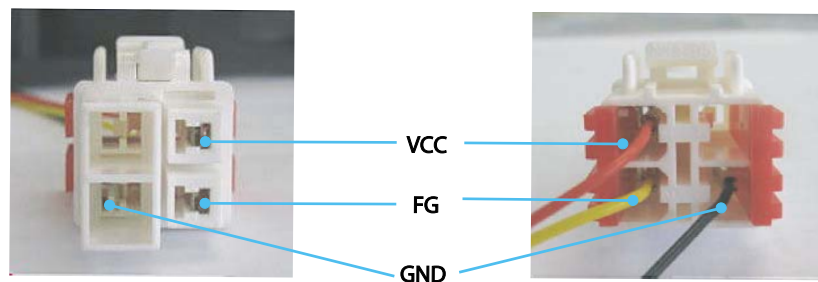

CIRCUIT DESCRIPTIONS

12-9. INTERNAL REFRIGERATOR FAN MOTOR OPERATING CIRCUIT

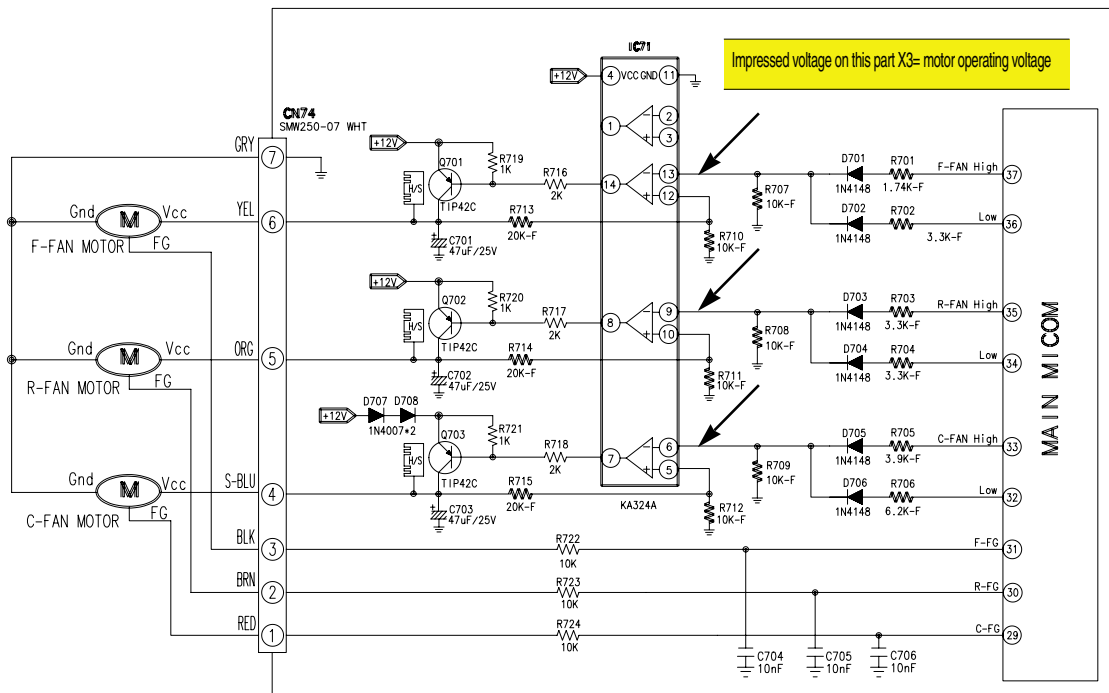

■ MOTOR DRIVE CIRCUIT DESCRIPTIONS

1) This refrigerator uses BLDC MOTORS for the purpose of saving power consumption, the BLDC MOTOR is used for the freezing compartment, cooling compartment, and machine room motor (this motor drive circuit is a common circuit used in other models)

2) PRINCIPLE OF OPERATION

In the above electric circuits, you may notice that the circuits are similar for each motor. For example, the F-FAN motor is represented here. FAN motor operates in high/low speed according to conditions. To operate the F-FAN, a certain voltage should be applied OP-AMP #13 PIN as shown in the Figure.

A certain voltage is applied OP-AMP #13 according to the operation of MICOM #37(HIGH RPM), #36(LOW PRM). Tripled by this voltage (Gain value currently set), you may get the voltage applied the motor.

If OP-AMP #13 PIN voltage is 3V, 9V is impressed into motor by $3V \times 3 = 9V$ formula.

3) COMPARISON IN HIGH/LOW SPEED

	VOLTAGE APPLIED TO MOTOR			REMARKS
	F-FAN	R-FAN	C-FAN	
HIGH	11.1V	9.7V	9.4V	In case of normal motor operation, a certain frequency is input to MICOM #31(F), #30(R), #29(C), and the MICOM checks out for any errors in motor operation based on this signal. (Frequency (Hz) x 12 = Motor rpm)
LOW	9.7V	9.7V	8.0V	

* Voltage errors range within $\pm 0.2V$.

13. REFERENCE INFORMATION

13-1) Model Name(Nomenclature)

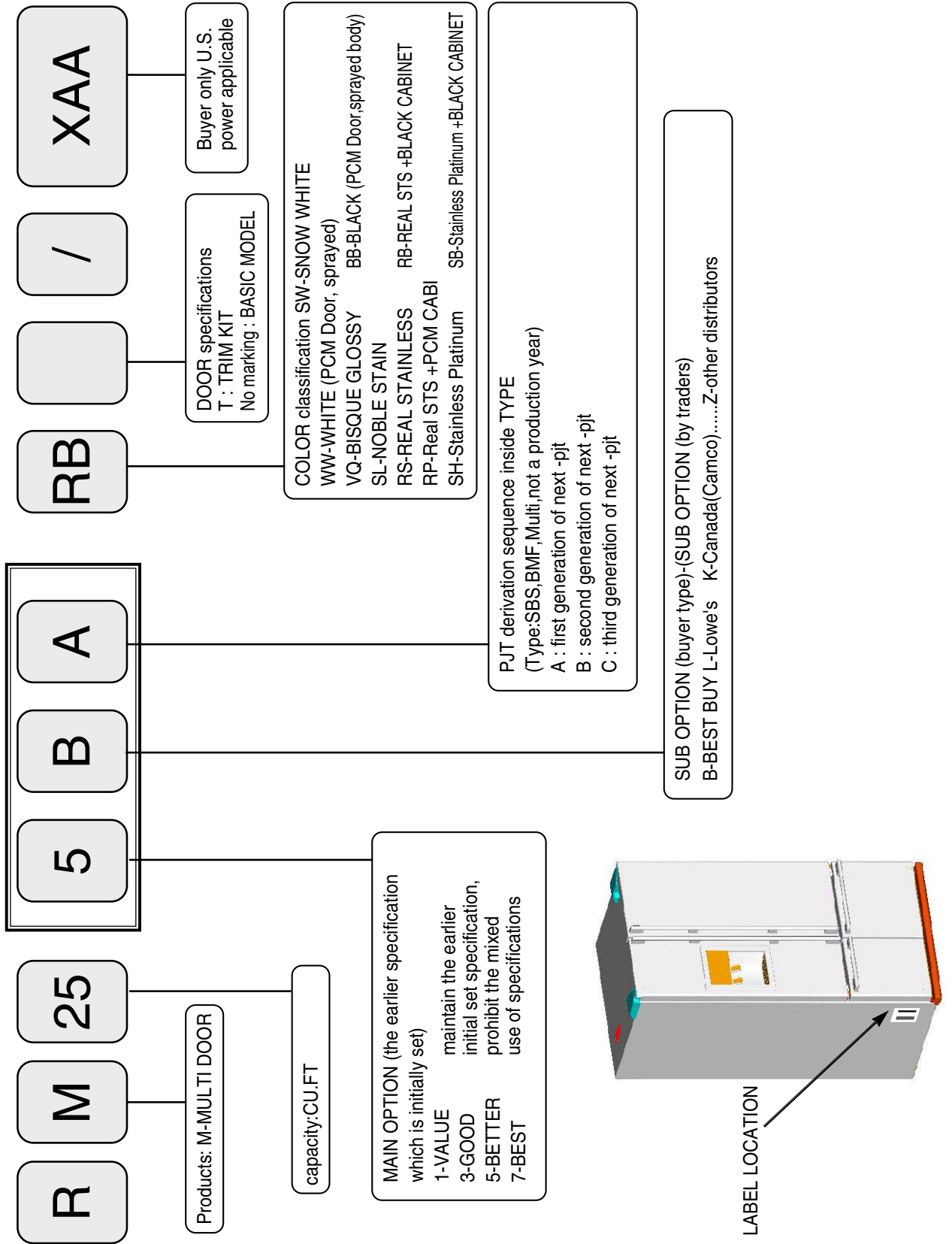

REFERENCE INFORMATION

13-2) Q & A

Problem	Possible Causes	What To Do
The refrigerator does not work sufficiently or at all	• Disconnected power plug	• Check that the power plug is properly connected.
	• Is the temperature control on the display panel set to the correct temperature?	• Try setting it to a lower temperature.
	• Is the refrigerator in direct sunlight or located near a heat source?	• Move the refrigerator to the proper location.
	• Is the back of the refrigerator too close to the wall?	
The food in the refrigerator is frozen	• Is the temperature control on the display panel set to the correct temperature?	• Try setting it to a warmer temperature.
	• Is the temperature in the room too low?	
	• Did you store the food with a high water content in the coldest part of the refrigerator.	
Unusual noises or sounds are heard		• Check that the floor is levelled and stable.
	• Is the back of the refrigerator too near to the wall?	• Move the refrigerator to the proper location.
	• Was anything dropped behind or under the refrigerator?	• Remove the foreign object.
	• A “ticking” sound may be heard from inside the refrigerator. This is normal and occurs because various accessories contract or expand.	
The front corners and sides of the cabinet are hot; condensation occurs	• HOT-PIPE is installed in the front corners of the refrigerator. That makes refrigerator’s temperature lower quickly and saves the power consumption.	• Normal state
	• Condensation can occur when you leave the door open for a long time.	• Normal state
Ice is not dispensed	• Did you stop the ice making function?	• See the control panel.
	• Is there any ice in the storage unit?	• See the ice container.
	• Is the water pipe connected and the shut-off valve open?	• See the valve.
	• Is the freezer temperature too warm?	• Set the temperature lower.
	• Did you wait for 12 hours after installation of the water supply line before making ice?	
You can hear water bubbling in the refrigerator	• The bubbling comes from the refrigerant circulating in the refrigerator and is normal.	• Normal state
There is a bad smell in the refrigerator	• Wrap strong smelling food so that it is airtight. Throw away any rotten food.	
Frost forms on the wall of the freezer wall		• Allow sufficient space between stored food for efficient air circulation.
	• Is the air vent blocked?	
	• Is the door closed properly?	
No water is supplied	• Is the water pipe connected and the shut-off valve open?	
	• Is the water supply pipe crushed?	
	• Is the water tank frozen because the refrigerator temperature is too low? Select a warmer setting on the display panel.	

REFERENCE INFORMATION

Problem	Possible Causes	What To Do
Small or hollow cubes	Water filter clogged.	• Replace filter cartridge with new cartridge or with plug.
	Door left open.	• Check to see if a package is holding the door open.
Slow ice cube freezing	Temperature control not set cold enough.	• See about the controls.
	Defrost heater is on.	• This is normal.
Cube dispenser does not work(on some models)	Icemaker turned off or water supply turned off.	• Turn on icemaker or water supply.
	Ice cubes are frozen to the icemaker feeler arm.	• Remove cubes and move the feeler arm to the ON position.
	Irregular ice clumps in the storage container.	• Break up with fingertip pressure and discard remaining clumps. • Freezer may be too warm. Adjust the freezer control to a colder setting, one position at a time, until clumps do not form.
	Dispenser is LOCKED.	• Press and hold the CHILD LOCK for 3 seconds.
Water has poor taste/odor (on some models)	Water dispenser has not been used for a long time.	• Dispense water until all water in system is replenished.
Water in first glass is warm (on some models)	Normal when refrigerator is first installed.	• Wait 24 hours for the refrigerator to completely cool down.
	Water dispenser has not been used for a long time.	• Dispense water until all water in system is replenished.
	Water system has been drained.	• Allow several hours for replenished supply to chill.
Water dispenser does not work(on some models)	Water supply line turned off or not connected.	• See Installing the water line.
	Water filter clogged.	• Replace filter cartridge or remove filter and install plug.
	Air may be trapped in the water system.	• Press the dispenser arm for at least two minutes.
	Dispenser is LOCKED.	• Press and hold the CHILD LOCK pad for 3 seconds.
Water spurting from dispenser (on some models)	Newly-installed filter cartridge.	• Run water from the dispenser for 3 minutes (about one and a half gallons).
Water is not dispensed (on some models) but icemaker is working	Water in reservoir is frozen.	• Call for service.
	Refrigerator control setting is too cold.	• Set to a warmer setting.
Water on kitchen floor or on bottom of freezer	Ice cubes stuck in icemaker. (Green power light on icemaker blinking).	• Turn off the icemaker, remove cubes, and turn the icemaker back on.
	Drain in the bottom of the freezer clogged.	• See Care and cleaning. • Check the lock on filter.
No water or ice cube production	Cubes jammed in chute.	• Poke ice through with a wooden spoon.
	Supply line or shutoff valve is clogged.	• Call a plumber.
	Water filter clogged.	• Replace filter cartridge or remove filter and install plug.
	Dispenser is LOCKED.	• Press and hold the CHILD LOCK pad for 3 seconds.

REFERENCE INFORMATION

13-3) Additional Information

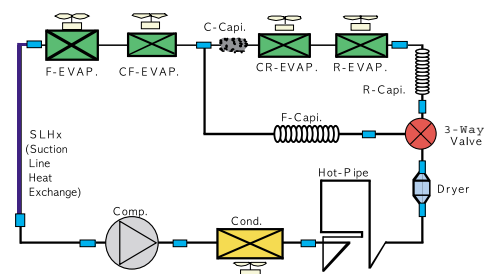
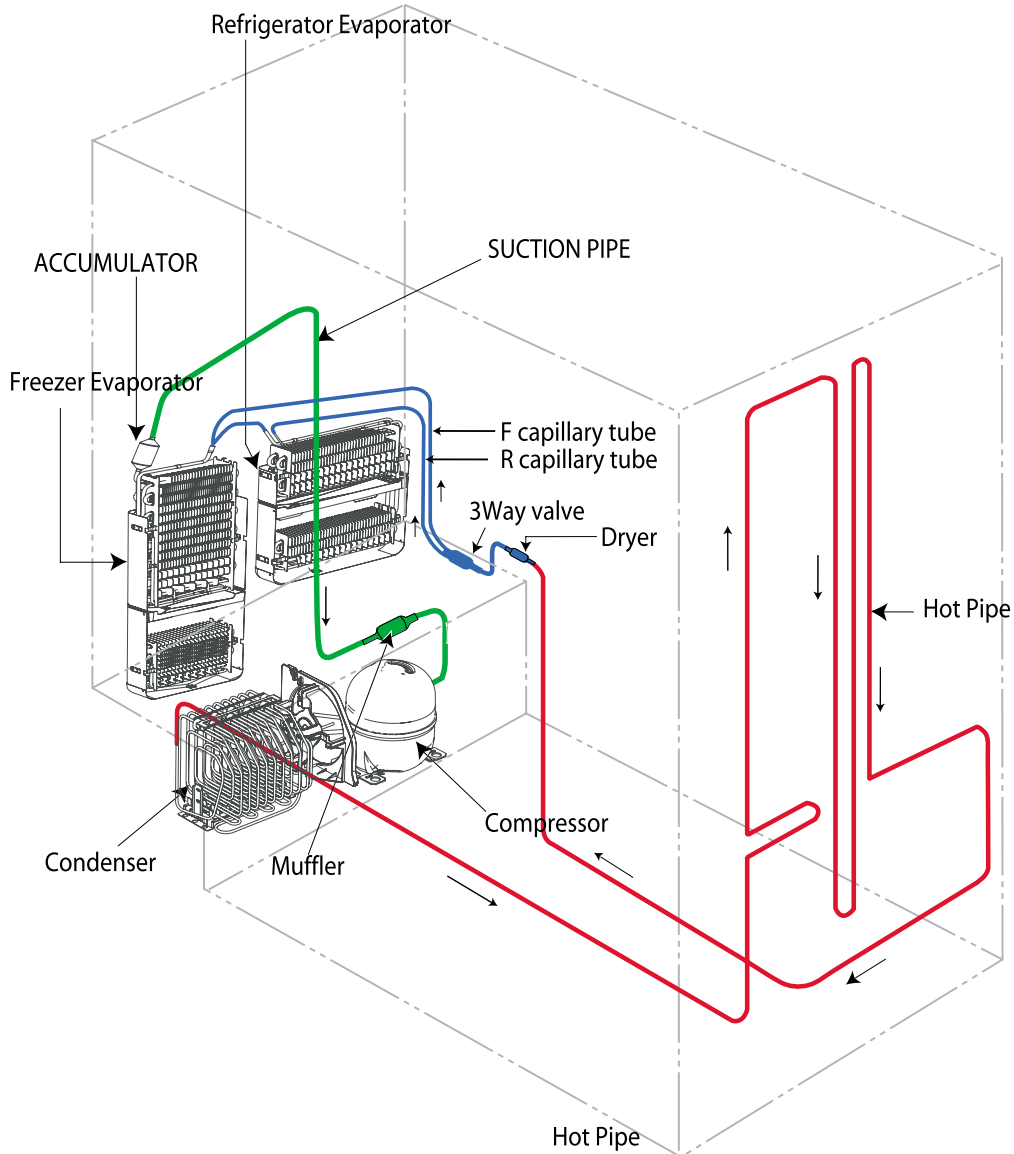
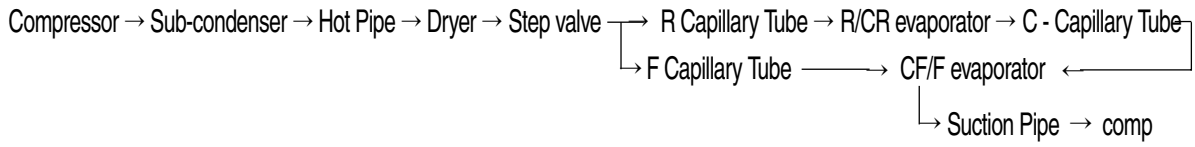

REFERENCE INFORMATION

Freezer

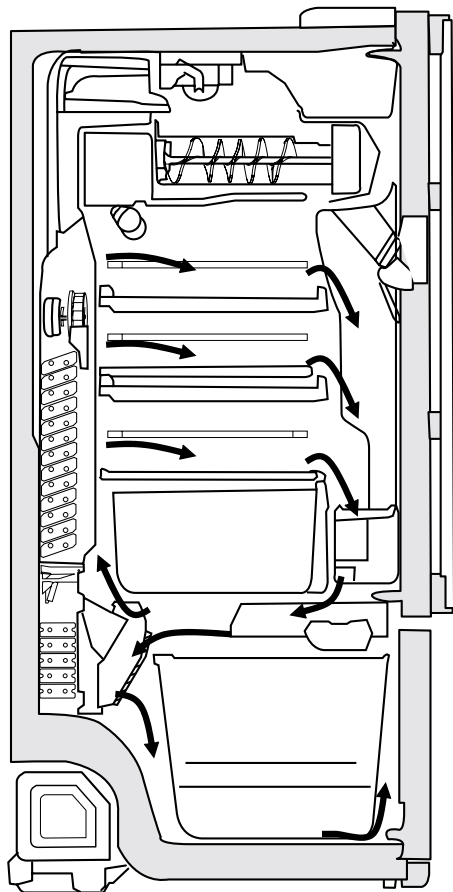

Refrigerator

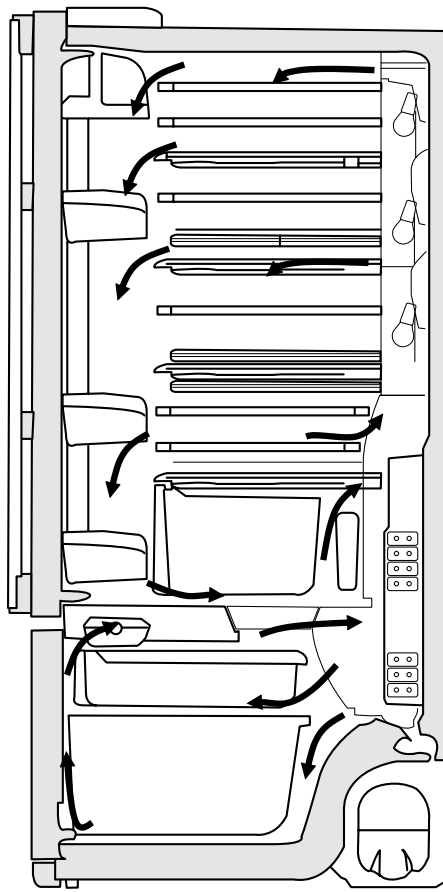

Notes:



***Be Aware, Be Alert
Always work safely.
On the Job, On the Road, In the Home
Every Time, All the Time***

