

LIEBHERR

Use and Care and Installation Manual

Fully integrated combined
refrigerator-freezers

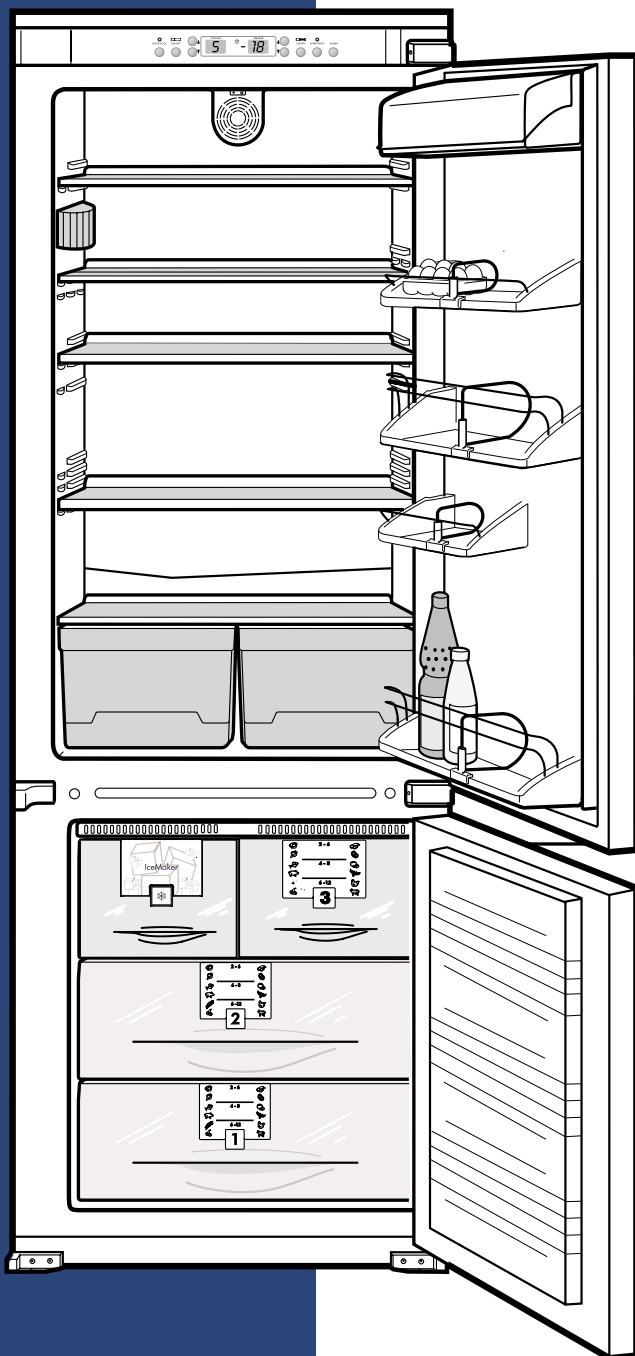

HC1001/HC1050
2606 7082 132-03

Congratulations on your purchase. Choosing this appliance means you want all the benefits of state-of-the-art refrigeration technology, guaranteeing you top quality, a long appliance life span and excellent reliability.

Your fully integrated combined refrigerator-freezer provides an elegant addition to your kitchen. The appliance blends in with your cabinets because it is actually mounted inside of a kitchen cabinet! The doors and handles are identical to the other cabinets in your kitchen.

The features on your appliance have been designed to ensure maximum convenience - day in, day out.

This appliance has been manufactured with recyclable materials using an environmentally friendly process, so together we're making an active contribution to the preservation of our environment.

To get to know all the benefits of your new appliance, please read the information contained in these operating instructions carefully.

We know you will be pleased with your new appliance.

Additional benefits

- CFC/FC-free
- Energy-optimized refrigerant circuit
- Energy-efficient insulation

- User-friendly electronic controls
- Temperature can be controlled within climate rating range, regardless of room temperature
- Refrigerator and freezer compartments defrost automatically - no need to spend time defrosting

- Big net-refrigerator capacity
- Variable and practical features
- Safety-glass storage shelves
- Big net-freezer capacity
- Shelves can be removed to make space for large items

- Freezer temperature increase alarm
- Audible door open alarm
- Power failure/FrostControl display
- Fresh food can be fast-frozen as required
- Frozen food temperature display
- Bright interior light
- Practical door arrangement for tall bottles

- Easy to clean
- Door hinges can be reversed
- Slider system for easy kitchen cabinet installation

A delight in freshness

LIEBHERR

Operating and Control Elements - *Figure 1*

Freezer

- (1) Temperature Display and Setting Display
- (2) Temperature Buttons
- (3) Main ON/OFF Button
- (4) SuperFrost Button with LED Showing Active Function
- (5) Alarm Button

Refrigerator

- (6) Childproof Lock (refrigerator and freezer display)
- (7) Temperature Display and Setting Display
- (8) Temperature Buttons
- (9) Refrigerator ON/OFF Button
- (10) SuperCooling Button
- (11) Fan with Rocker Switch

Description of Refrigerator

- (12) Butter and Cheese Compartment
- (14) Adjustable Storage Shelves
- (15) Interior Light
- (16) Vegetable, Salad and Fruit Bins
- (17) Defrost Drain (refrigerator)
- (18) Adjustable Bottle Holder
- (19) Door Rack for Large Bottles and Drinks
- (20) Model Plate
- (21) Coldest Area of Refrigerator, Suitable for Heat-Sensitive and Highly Perishable Foods

Description of Freezer

- (22) Re-circulated Air Slits
- (23) IceMaker (some models)
- (24) Removable Shelf to Make Space for Large Items
- (25) Drawers with Information System
- (26) Ice Cube Tray (only in models without IceMaker)

Model Plate

- (27) Type Designation
- (28) Service Number
- (29) Appliance/Serial Number

IMPORTANT

PLEASE READ AND FOLLOW THESE INSTRUCTIONS

These instructions contain Warning and Caution statements. This information is important for safe and efficient installation and operation.

Always read and follow all Warning and Caution statements!



DANGER

States a hazard will cause serious injury or death if precautions are not followed.



WARNING

Warning indicates a potentially hazardous situation which, if not avoided, could result in death or serious injury.



CAUTION

Caution indicates a potentially hazardous situation which, if not avoided, may result in minor or moderate injury.

CAUTION

This highlights information that is especially relevant to a problem-free installation and operation.

Make sure incoming voltage is the same as the appliance rating.

To reduce the risk of fire, electric shock, or personal injury, installation work and electrical wiring must be done by a qualified electrician in accordance with all applicable codes and standards, including fire-rated construction.

TABLE OF CONTENTS

Contents	Page
Installation Guidelines	2
Area Requirements	2
Electrical Requirement	2
Customer's Responsibility	2
Venting the Appliance.....	2
Disposal of Old Appliance.....	3
Important Safety Information.....	3
Electrical Safety.....	4
Unpacking	5
Disposal of Carton.....	5
Examining Loose Parts	5
Installation	6
Kitchen Cabinet Construction.....	6
Designing the Kitchen Cabinet Doors.....	9
Reversing Door Hinges	10
Water Connection For IceMaker Models Only.....	11
Connection to the Water Supply	11
Installing Into a Kitchen Cabinet	13
Attaching the Kitchen Cabinet Doors.....	18
Operation	19
Safety Regulations	19
Turning the Appliance ON and OFF	19
Setting the Temperature	20
Childproof Lock.....	20
Changing the Temperature Display	21
Temperature Display.....	21
Display Brightness.....	21
Alarm	22
Power Failure/FrostControl Display	22
SuperCooling.....	23
Cooling with Fan.....	23
Refrigerator Compartment	24
Arranging Food.....	24
Shelf Arrangement.....	24
Interior Light.....	25
Freezer Compartment	26
SuperFrost	26
Freezing and Storage	26
Freezer Tray	28
Information System.....	28
Making Ice Cubes.....	28
To Start the IceMaker	29
To Clean the IceMaker	30
Notes on Defrosting.....	31
Cleaning.....	31
Energy Saving Tips	31
Troubleshooting	32
Customer Service	33
Appliance Information	33

NOTE

All types and models are subject to continuous improvement. The manufacturer reserves the right to make modifications in the shape, equipment and technology.

A delight in freshness

INSTALLATION GUIDELINES

Area Requirements

Verify the following:

- Floors can support refrigerator's weight plus approximately 1200 pounds (544 kg) of food weight.
- Finish kitchen floor height is level. Kitchen cabinet that the appliance is installed in must be shimmed to the floor level if the floor heights are not equal.
- Remove anything attached to the rear or side walls of appliance that would prevent proper installation or impede proper ventilation.
- Cutout dimensions are accurate.
- Electrical outlet is in correct location.

Do not install this refrigerator-freezer next to any other refrigerator or freezer except another Liebherr model. Liebherr models are designed to allow side-by-side installation. They are equipped with a heating system to eliminate condensation when refrigerators or freezers are installed side-by-side. Installing this refrigerator-freezer next to any other refrigerator or freezer can cause condensation or cause damage to the Liebherr refrigerator-freezer.

Electrical Requirement

If codes require a separate grounding circuit to be used, have a qualified electrician install the circuit.

WARNING

ELECTRICAL SHOCK HAZARD!

- **Do not ground to a gas pipe. Check with a qualified electrician if you are not sure the appliance is properly grounded. Do not have a fuse in the neutral or grounding circuit.**
- **Failure to follow these instructions could result in death or serious injury.**

WARNING

ELECTRICAL SHOCK HAZARD!

- **Electrically ground refrigerator.**
- **Do not use an extension cord.**
- **Failure to follow these instructions could result in fire, death or serious injury.**

WARNING

ELECTROCUTION HAZARD!

- Electrical Grounding Required. This appliance is equipped with a three-prong (grounding) polarized plug for your protection against possible shock hazards.**
- **DO NOT remove the round grounding prong from the plug.**
 - **DO NOT use a two-prong grounding adapter.**
 - **DO NOT use an extension cord to connect power to the unit.**
 - **Failure to follow these instructions could result in death or serious injury.**

Customer's Responsibility

A 115 Volt, 60 Hz, 15 Amp fused electrical supply is required. We recommend using a dedicated circuit for this appliance to prevent electrical overload. Follow the National Electrical Code and local codes and ordinances when installing the receptacle.

Venting the Appliance

DO NOT restrict the air flow. Air flow must be provided for the appliance to operate. The factory air vents provide 31 square inches (200 cm²) of air flow per appliance. If you are replacing the factory air vents with an overlay, the air flow must be the same or greater than the factory air vents.

INSTALLATION GUIDELINES



DANGER

Disposal of Old Appliance

Be sure to follow your local requirements for disposal of appliances. Discarded appliances can be dangerous. To help prevent an accident:

- Remove the door(s).
- Cut off the power cable from the discarded appliance.
- Cut off the prongs from the power cable plug and discard them.
- Leave the shelves and drawers in place.

Following these instructions reduces the possibility of causing personal injury, especially to children playing.

Contact the trash collection agency in your area for additional information.

Important Safety Information

This appliance is intended for domestic use only. Use the appliance only for its intended purpose, the storage of food products. Follow the cautions and safety warnings throughout this instruction manual including the following:

- Do not allow children to play with the appliance. Children must not climb, sit or stand on the shelves, drawers or door.
- To prevent possible injury due to an electrical shock, be sure to disconnect the power cord or turn off the circuit breaker before replacing the interior light or cleaning the appliance.
- To prevent possible injury due to broken glass, use hand protection when replacing the interior light.
- To prevent possible injury or damage to the appliance, do not use steam cleaning equipment to clean the appliance.
- Do not operate the appliance in the presence of explosive fumes.

- In the event of a power outage, minimize opening the appliance door(s). Protect the food either by placing dry ice on top of the packages or using a local frozen food locker if the power failure is of a long duration. Do not attempt to re-freeze any frozen food that has thawed out.
- To avoid possible injury, only adjust an empty shelf. Do not attempt to adjust a shelf with food on it.
- Wait 30 minutes to 1 hour after installation before you plug in the appliance. This allows the refrigerant and system lubrication to reach equilibrium.



WARNING

ELECTRICAL SHOCK HAZARD!

- **Start-up should only take place if the appliance has been installed according to these instructions.**
- **Failure to follow these instructions could result in death or serious injury.**

INSTALLATION GUIDELINES

Electrical Safety

Connect this appliance to a 110-120 VAC, 15 amp circuit that is controlled by a circuit breaker or fuse. In some communities, a wall switch is required to turn power to the appliance OFF and ON. This appliance should have its own separate grounded circuit. Do not use an extension cord.

The top of the electric outlet must be located within 82-5/8 in. (2100 mm) (Figure 2) from the top of the base in the cabinet.

The power cord is equipped with a three-prong (grounding) plug for your protection against possible shock hazards. To maintain this protection:

- Do not modify the plug by removing the round grounding prong.
- Do not use a two-prong adapter. Where a two-prong wall receptacle is encountered, contact a qualified electrician and have it replaced with a three-prong receptacle in accordance with all local codes and ordinances.
- Do not use a power cord that is frayed or damaged.

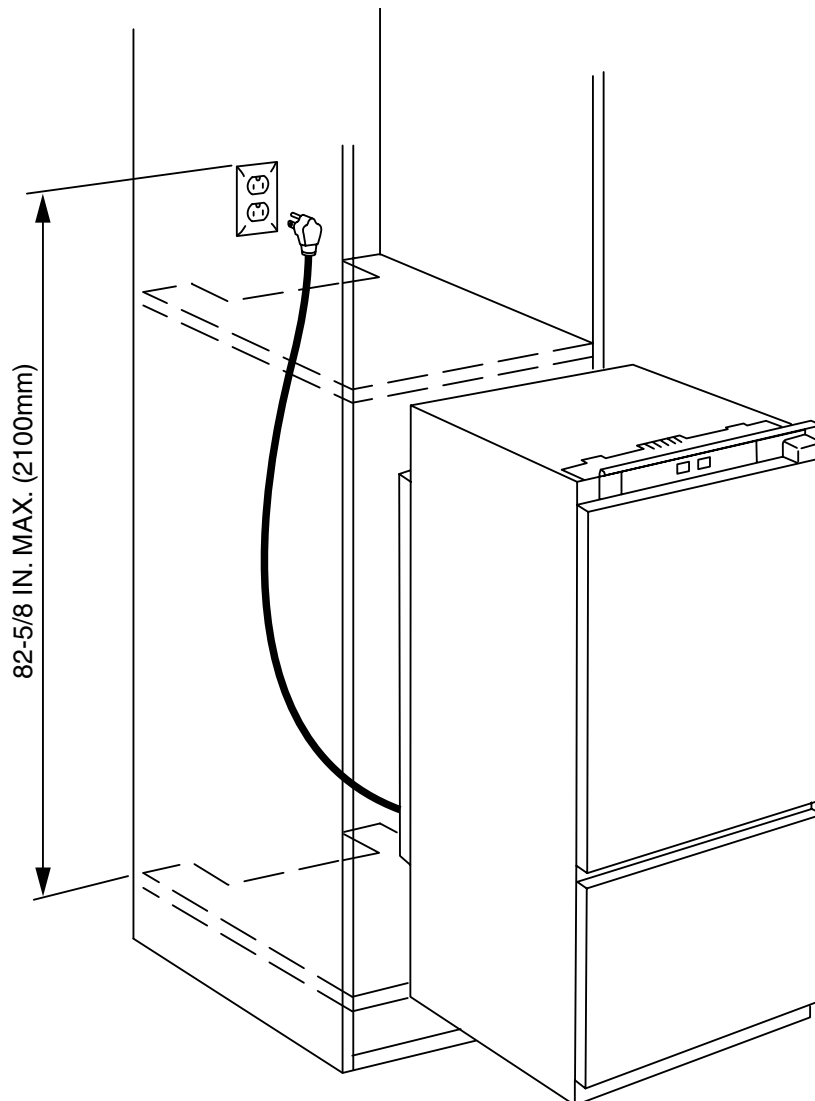

Figure 2

⚠ CAUTION

BACK INJURY HAZARD!

- To avoid risk of personal injury or property damage, have two people unpack and move this appliance into place.
- Failure to follow these instructions may result in minor or moderate injury.

⚠ CAUTION

Protect the finished floor surface before you uncrate the appliance.

As soon as you uncrate the appliance:

- Examine the unit and packaging for shipping damage. Contact the carrier immediately if you suspect there is any damage.
- Note the type (model number), service number, appliance / serial number, date of purchase and where purchased on the spaces provided in the back of this manual.

Disposal of Carton

The packaging is designed to protect the appliance and individual components during moving and is made of recyclable materials. Please take the packaging material to your local recycling facility.

- Corrugated board/board
- Molded polystyrene (foamed, CFC-free polystyrene)
- Polythene bags and sheets
- Polypropylene straps

⚠ WARNING

SUFFOCATION HAZARD!

- Keep packaging materials away from children. Polythene sheets and bags can cause suffocation!
- Failure to follow these instructions could result in death or serious injury.

Examining Loose Parts - Figure 3

Make sure you received all installation and other loose parts. Note the vinyl trim may be taped to the front of the unit. If any parts are missing, contact your Liebherr dealer.



1. Freezer Tray
2. Ice Cube Tray (only with appliances without IceMaker)

Figure 3

INSTALLATION

Kitchen Cabinet Construction

This is a fully integrated refrigerator-freezer which means that it is **fully enclosed** by a kitchen cabinet. This type of cabinet must be carefully constructed using the proper dimensions **and it must provide proper ventilation** to ensure proper appliance operation.

Kitchen Cabinet Airflow

1. The following ventilation dimensions must be observed:
 - There must be a ventilation space at least 31 in.² (200 cm²) at the airflow inlet (**Fig. 4, 1**) **and** at the airflow outlet (**Fig. 4, 2**).
 - There must be a clear ventilation space (**without any obstructions**) of at least 1-1/2 in. (38 mm) at the back of the kitchen cabinet (**Figure 5**).
 - The top ventilation space can be either directly over the appliance (**Fig. 4, 2**) or next to the ceiling over a cabinet (**Fig. 4, 3**), or through a vent installed in a soffit (**Fig. 4, 4**).

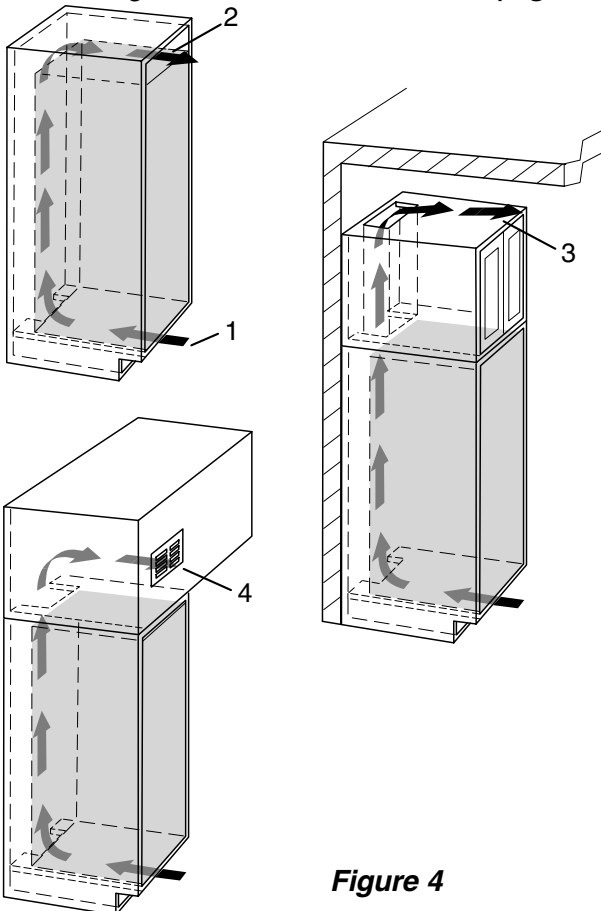

Figure 4

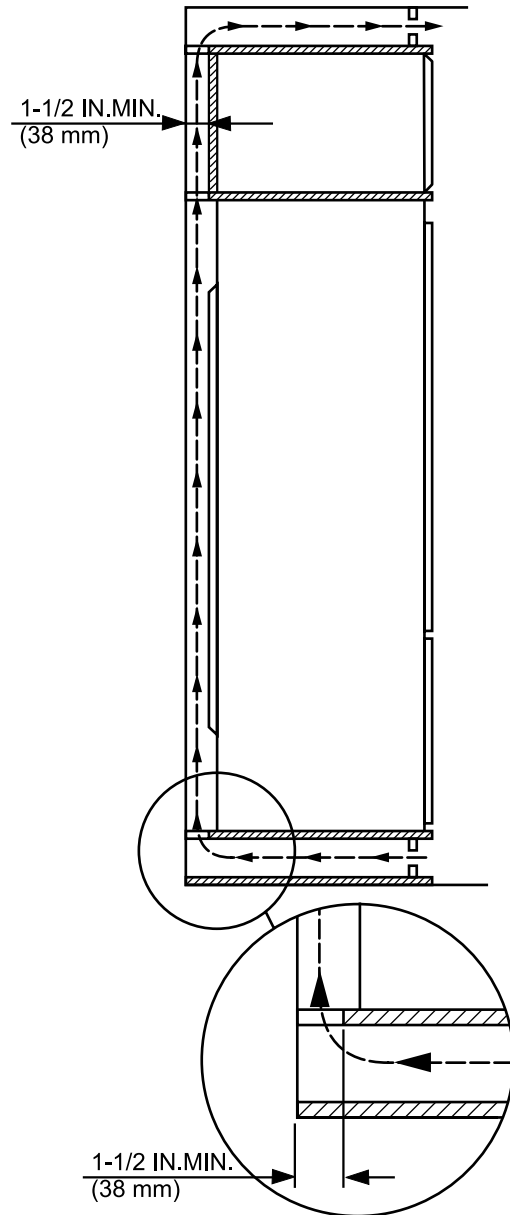

Figure 5

2. Ventilation through the cabinet base at the bottom can be achieved by installing the provided ventilation grille (**Fig. 6, 3**) or via a ventilation opening of at least 31 in.² (200 cm²).

When using the provided ventilation grille (**Fig. 6, 3**), please proceed as follows:

- In the cabinet base, cut out a ventilation opening that is 17-23/32 in. (450 mm) in width and 2-7/32 in. (56 mm) in height (**Figure 6**).
- Insert ventilation (**Fig. 6, 3**) grille into the cabinet base cut-out (**Fig. 6, 1**).
- From the back side, slide the snap-fits (**Fig. 6, 2**) into the grille until the hooks make contact with the cabinet base.
- Completely mount cabinet base (with ventilation grille and snap-fits) to kitchen cabinet.

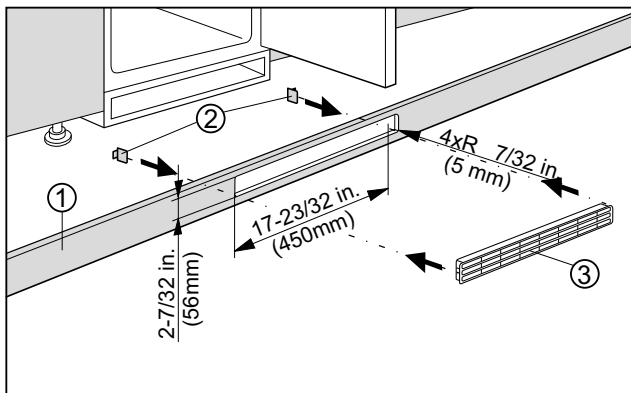

Figure 6

Construction of Kitchen Cabinet - *Figure 7*

Construct the kitchen cabinet using the dimensions shown in **Figure 7**.

1. Align the kitchen cabinet with a level (**Fig. 7, 2**) and a square. If necessary, shim underneath the cabinet to make it level. The floor and side walls must be at right angles to each other.
2. Install the refrigerator-freezer in stable kitchen cabinets only.
3. The joint between the upper and the lower kitchen cabinet door must align with the joint between the upper and lower refrigerator-freezer door.

If you use a pre-designed kitchen cabinet, you may need to shim the refrigerator-freezer so the doors are properly aligned.

Follow the dimensions provided in **Figure 7** to determine if any shims (**Fig. 7, 4**) are required. Also make sure you adjust the height of the kitchen cabinet (**Fig. 7, Dimension "D"**) if you need to add any shims.

4. Use a fish line (**Fig. 7, 1**) to pull the plug up to reach the outlet (**Fig. 7, 3**).

INSTALLATION

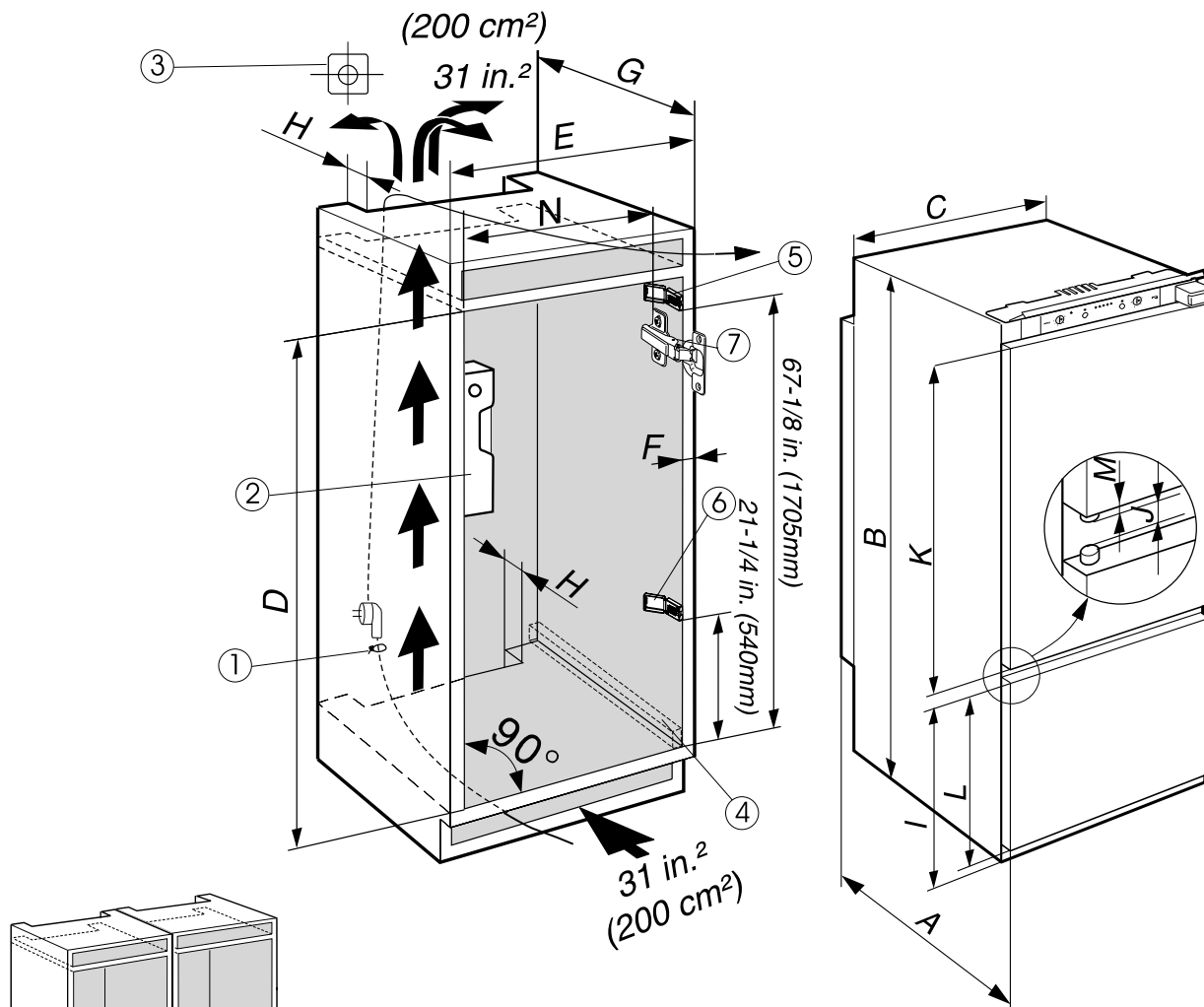

Figure 7

Make a separate kitchen cabinet for each appliance for Side by Side installations.

- A. 21-7/32" (544 mm)
- B. 69-5/8" (1772 mm)
- C. 21-1/4" (540 mm)
- D. 69-25/32" - 70-3/8" (1772 - 1788 mm)
- E. 24" (609.6 mm) (American Style Cabinet)
- 23-5/8" (600 mm) (European Style Cabinet)
- G. 21-21/32" (550 mm) minimum
- H. 1-1/2". (38 mm) minimum
- I. 26-13/16" (681 mm)
- J. 15/16" (24 mm)
- K. 39-27/32" (1012 mm)
- L. 26-1/8" (664 mm)
- M. 1/8" (3 mm)
- N. 21-7/16" (544.5 mm)

(clearance needed between kitchen cabinet hinge projection and inside of left wall of kitchen cabinet)
Ventilation space at least 31 in.² (200 cm²) is required.

- ① Fish line for power cord
- ② Level
- ③ Electrical Outlet, The top of the electric outlet must be located within 82-5/8 in. (2100 mm) (Figure 2) from the top of the base in the cabinet.
- ④ Place shims under appliances as necessary
- ⑤ Upper cabinet spacer for 24 in. (610 mm) cabinet width (dimension "E") ONLY
- ⑥ Lower cabinet spacer for 24 in. (610 mm) cabinet width (dimension "E") ONLY
- ⑦ Kitchen Cabinet Hinge

Designing the Kitchen Cabinet Doors

You need two doors for the kitchen cabinet, one on top for the refrigerator compartment, and one on the bottom for the freezer compartment. In general, the doors have these characteristics:

- The doors should be at least 5/8 in. (16 mm) thick to allow the connecting rails to be fastened to them.
- With both doors closed, there should be a minimum of 1/8 in. (3 mm) between the upper and lower doors. Also, there should be an 1/8 in. (3 mm) clearance between the upper door and the cabinet door above it (if any).
- The top edge of the upper door (**Fig. 8, 1**) and lower door (**Fig. 8, 2**) should be even with the doors of adjoining cabinet(s), if any.
- **The position of the joint between the kitchen cabinet doors must be level with the position of the joint between the appliance doors (Fig. 8, 2).**
- Adjust the door alignment *before* installing the appliance. It is impossible to adjust the door with the appliance installed.
- Check the installation dimensions according to **Figure 7**.
- Use high quality inside hinges (**Fig. 9, 1**) to mount the doors to the cabinet. The hinges should be adjustable to make sure the doors fit squarely when they are closed.
- Make sure that you account for the projection (thickness) of the hinge you select. You must have 21-7/16 in. (544.5 mm) clearance between left inner wall of the cabinet and the projection (thickness) of the hinge. See **Figure 7** dimension "N."
- The maximum hinge opening angle is 110°.
- Consider having a professional install the refrigerator-freezer in your kitchen cabinet.

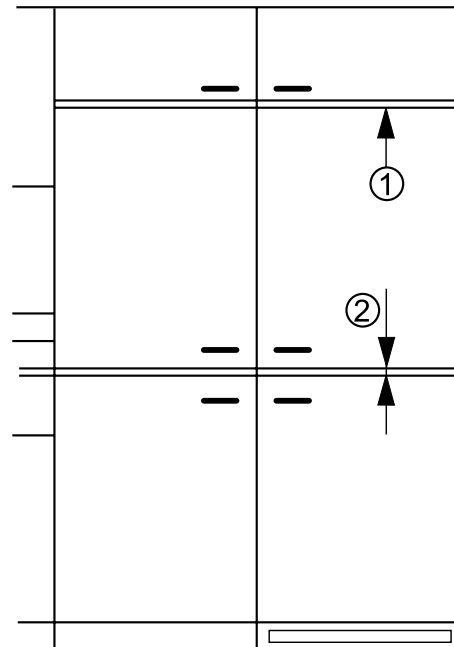

Figure 8

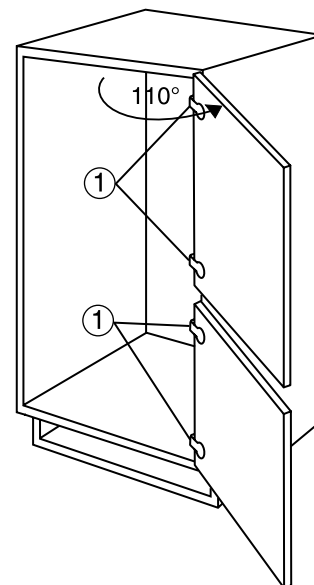

Figure 9

INSTALLATION

Reversing Door Hinges - Figure 10

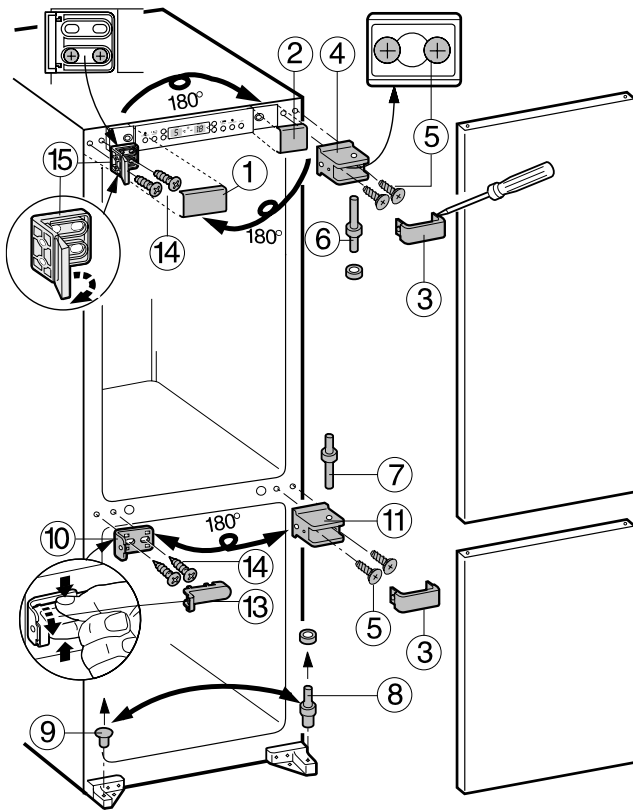

Figure 10

The door hinges can be changed from one side to the other if desired.

1. Pull off the covers (**Fig. 10, 1**) and (**Fig. 10, 2**).
2. Open bracket (**Fig. 10, 15**) and remove screws (**Fig. 10, 14**). When installing into the kitchen cabinet, replace bracket on the opposite side using the same screws.
3. Using caution, press in the side of the hinge covers (**Fig. 10, 3**) with a tool and remove covers.
4. Unthread the outside screw (**Fig. 10, 5**) in the hinge, halfway. Remove the inside screw completely.

5. Open the top door slightly. Push the door and hinge (**Fig. 10, 4**) out and remove simultaneously.
6. Remove the hinge pin (**Fig. 10, 7**). Pull out the bottom door and remove.
7. Remove the plug (**Fig. 10, 9**).
8. Transfer the hinge pin (**Fig. 10, 8**) to the other side.
9. Remove the bracket (**Fig. 10, 10**) and cover (**Fig. 10, 13**) by pressing the cover together, then tilt out the bottom. When installing into the kitchen cabinet, replace on the opposite side using the same screws.
10. Remove the center hinge screws (**Fig. 10, 5**). Remove the center hinge (**Fig. 10, 11**). Rotate hinge 180° and install on the opposite side using the same screws. Thread the outside screw halfway in. Attach the hinge through the keyhole-shaped hole and slide in. Tighten both screws.
11. Place the bottom door on the hinge pin (**Fig. 10, 8**). Close door and insert the center hinge pin (**Fig. 10, 7**) with the longer side down. Be sure washers are in place.
12. Place the top door on pin (**Fig. 10, 7**) and close door.
13. Place the top hinge (**Fig. 10, 4**) together with pin (**Fig. 10, 6**) with the longer side up in the door mounting hole. Tilt the door away slightly and suspend the hinge on the screw (**Fig. 10, 5**). Slide the door in and tighten both screws.
14. Check for proper alignment of all doors. Adjust if necessary.

Water Connection For IceMaker Models Only - Figure 11

⚠ WARNING

ELECTRICAL SHOCK HAZARD!

- **Disconnect the water supply before connecting the water lines for the IceMaker. Make sure the refrigerator is not plugged in and there is no electric power going to the refrigerator.**
- **Failure to follow these instructions could result in death or serious injury.**

- The water pressure must be between 21.8-87.0 psi (1.5-6 bar).
- Use a 1/4 in. OD copper line to connect the water supply to the solenoid valve. This is not supplied with the refrigerator (**Figure 11**).
- A shut-off valve, such as the saddle valve illustrated here, must be installed between the hose line and the main water supply so the water supply can be stopped if necessary.

Do not install the shut-off valve behind the refrigeration unit.

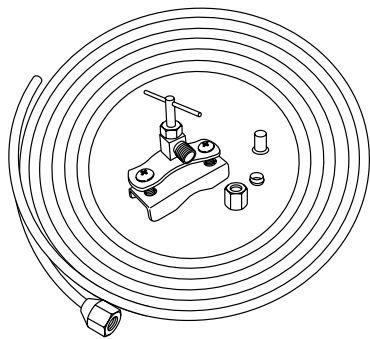

Figure 11

- If you have hard water, we recommend you install a water softener. Also, a filter must be installed if the water contains solids such as sand.
- All equipment and devices used to supply the water to the appliance must comply with the current regulations for your geographical area.

Connection to the Water Supply - Figures 12, 13

1. Install the shut-off valve, water filter and automatic shut-off device as required.

Note

The solenoid valve is located at the rear of your refrigerator-freezer.

2. Place a 1/4" OD copper tubing between the shut-off valve and solenoid valve. Make sure there is approximately 30" (70 cm) of excess tubing behind the unit for easy connection.

IMPORTANT

The solenoid valve has a Metric R3/4 male connection.

A R3/4(metric) to a 1/4" OD adapter and cable clip are supplied with the icemaker.

3. Remove the cover cap (**Fig. 13, 4**) from the solenoid valve (**Fig. 13, 1**). Install the brass adapter (**Fig. 13, 2**) with sealing ring (**Fig. 13, 6**) on the solenoid valve (**Fig. 13, 1**). Attach the copper tube to the brass adapter (**Fig. 13, 2**). Secure the copper tube (**Fig. 13, 3**) to the appliance using the cable clip (**Fig. 13, 5**).
4. Open the shut-off valve for the water supply and check the entire water system for leaks. Before the appliance is used for the first time, a licensed plumber should bleed air from the system.
5. Insert the electrical plug for the appliance into the electrical outlet (**Figure 12**).
6. Move the combined refrigerator-freezer into final position in the cabinet.

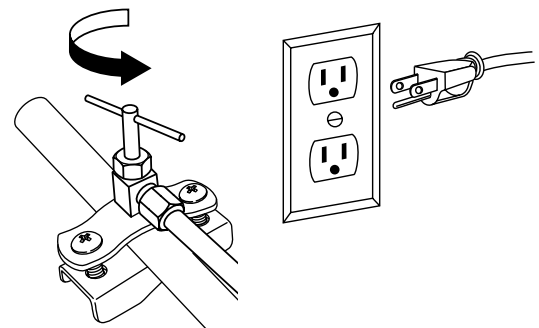

Figure 12

A delight in freshness

INSTALLATION

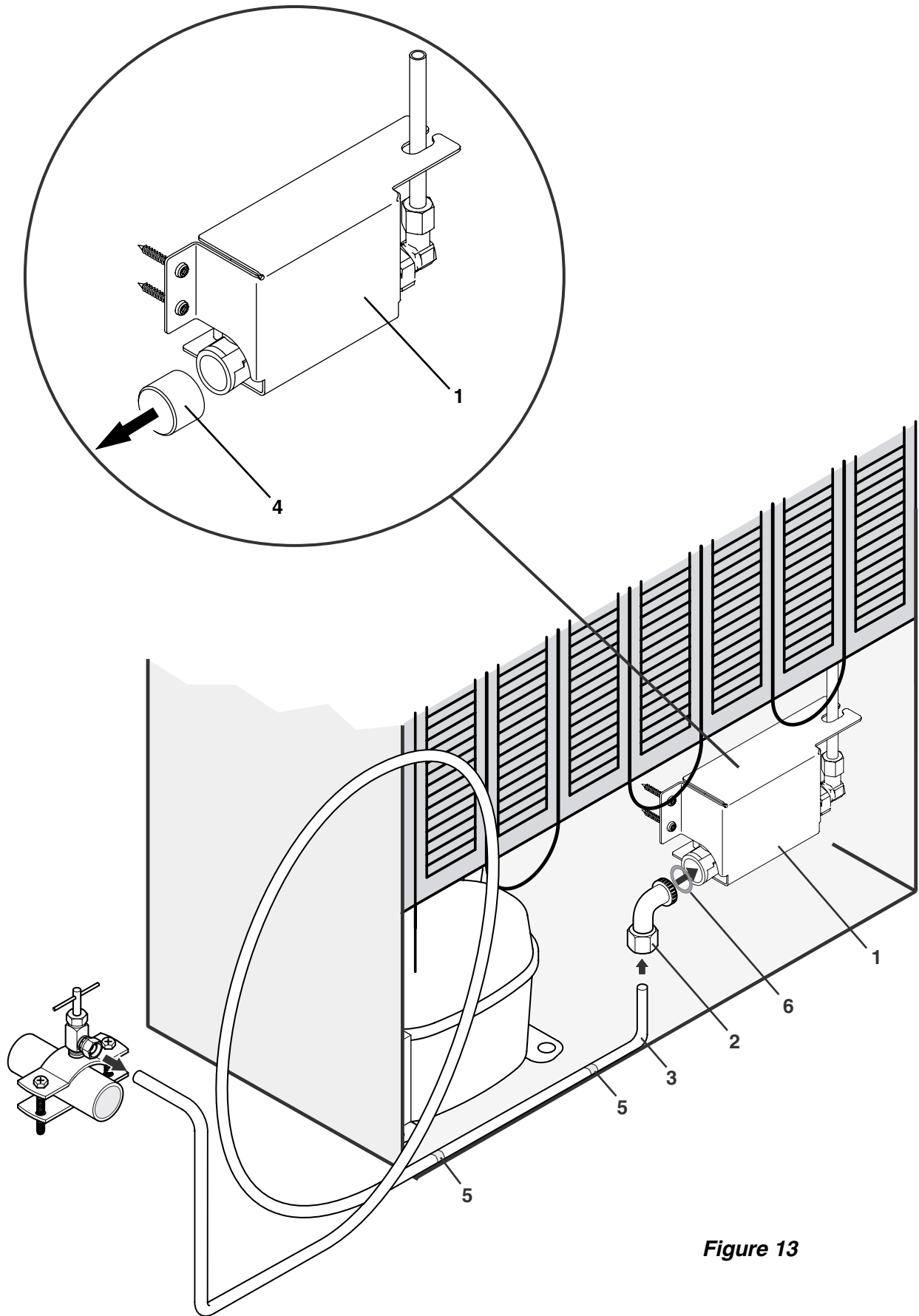

Figure 13

A delight in freshness

Installing Into a Kitchen Cabinet















<p>②①</p> <p>1x</p> 	<p>②②</p> <p>2x</p>  <p>∅ 3,5 x 8</p>	
<p>②②</p> <p>13x</p> <p>∅ 4 x 14</p> 	<p>②③</p> <p>2x</p> 	<p>②④</p> <p>2x</p> <p>∅ 5 x 75</p> 
<p>②⑤</p> <p>1x</p> 	<p>②⑥</p> <p>2x</p> 	<p>②⑦</p> <p>2x</p> <p>∅ 5 x 80</p> 
<p>②⑧</p> <p>4x</p> 	<p>②⑨</p> <p>4x</p> <p>∅ 3,9 x 9,5</p> 	<p>③③</p> <p>4x</p> <p>∅ 4 x 19</p> 
<p>③①</p> <p>4x</p> 	<p>③①</p> <p>4x</p> 	<p>③②</p> <p>2x</p> 

Figure 14

All attachment components are provided.

CAUTION

To protect the appliance from possible damage, allow the appliance to stand 30 minutes to 1 hour in place before turning the electricity on. This allows the refrigerant and system lubrication to reach equilibrium.

1. Insert the equalizer trim (Fig. 15, 20) in the slot so it is **flush on the handle side** and on the edge of the appliance front. Secure to the appliance with collar screws (Fig. 15, 21).

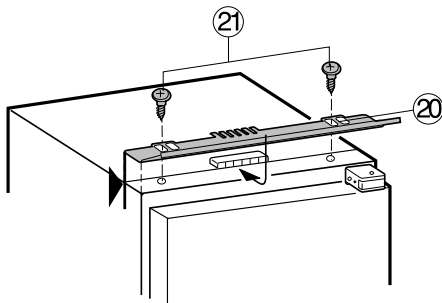

Figure 15

2. Gently pry open the top bracket cover (Fig. 16, 1).

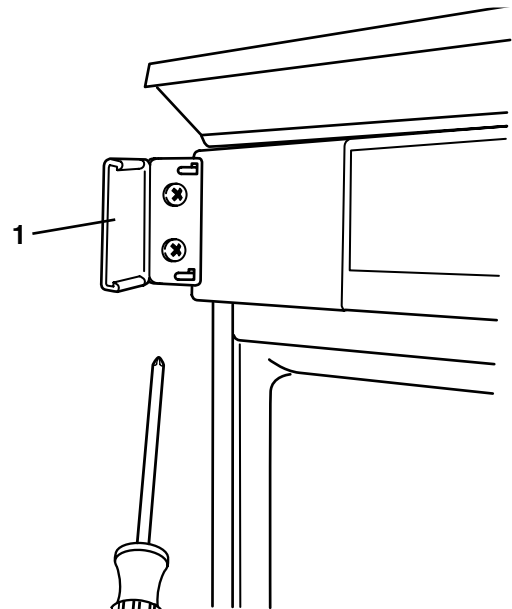

Figure 16

3. Position the power source cable so it can be easily connected once the appliance is installed. Use a piece of string to fish the cable (Fig. 7, 1) if necessary.

INSTALLATION

4. If the kitchen cabinet is 24 in. (609.6 mm) wide (American Style Cabinet):

- If the kitchen cabinet is 24 in. (609.6 mm) wide, one or two cabinet spacers, (**Fig. 7, 5**) and (**Fig. 7, 6**), are required. These cabinet spacers are supplied with the appliance.
- If the upper cabinet spacer (**Fig. 7, 5**) *does not* interfere with the top kitchen cabinet door hinge, install it in the location shown in **Figure 7** using the screws provided (**Fig. 17, 33**). Make sure the front edge of the spacer is recessed 1/8 in. (3 mm) from the edge of the kitchen cabinet wall. The plastic hinge of the cabinet spacer should face the rear wall of the cabinet.
- All 24 in. (609.6 mm) wide cabinets require the lower cabinet spacer (Fig. 7, 6).** Install it in the location shown in **Figure 7** using the screws provided (**Fig. 17, 33**). Make sure the front edge of the spacer is recessed 1/8 in. (3 mm) from the edge of the kitchen cabinet wall. The plastic hinge of the cabinet spacer should face the rear wall of the cabinet.
- Close the cap(s).

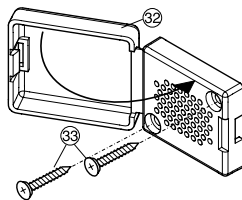

Figure 17

5. Slide the appliance into the kitchen cabinet (**Figure 18**):

- Make sure the handle side of the appliance is against the kitchen cabinet.
- Make sure the front of the bottom bracket and front of the bottom hinge (**Fig. 18, 1**) are flush with the front edge of the kitchen cabinet.
- Align the front edge of the open top bracket (**Fig. 18, 2**) so it is flush with the front edge of the kitchen cabinet. With the top bracket open, the distance between the front edge of the kitchen cabinet and the appliance housing must be 1-11/16 in. (43 mm).
- Verify the distance between the front edge of the kitchen cabinet and the appliance on the hinge side (**Fig. 18, 3**) is 1-11/16 in. (43 mm).

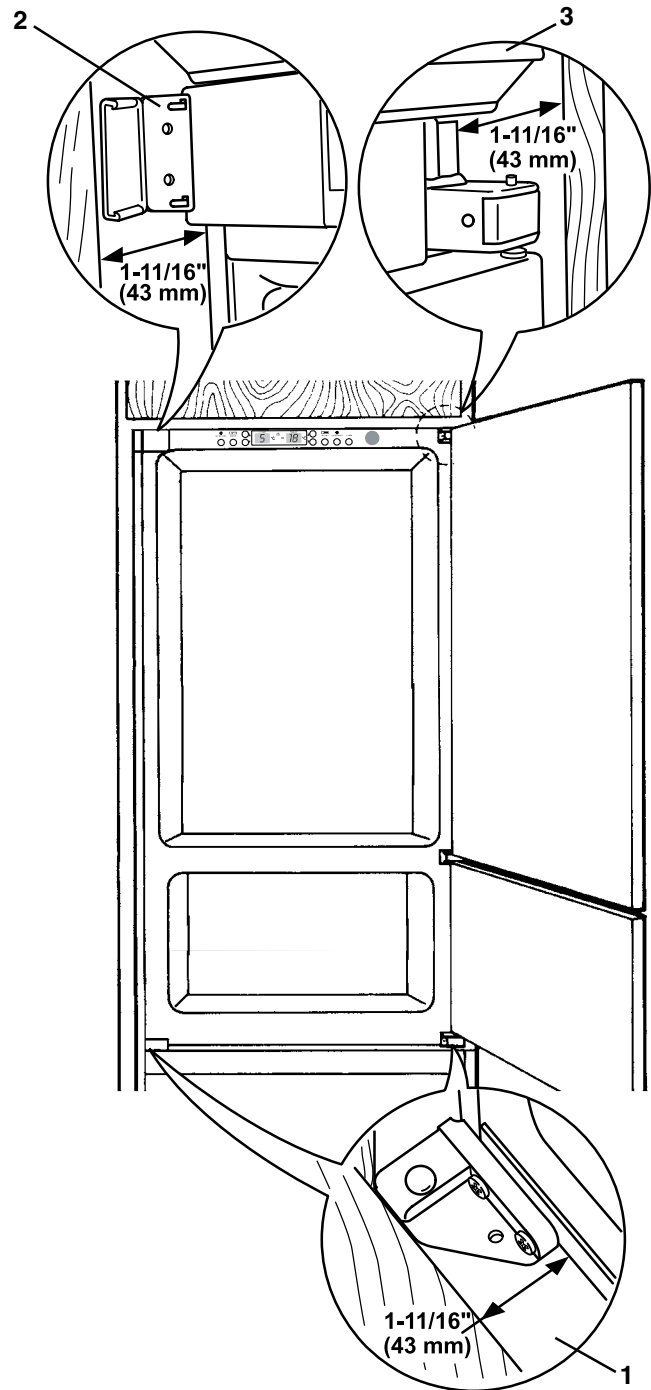

Figure 18

6. Secure the appliance into the kitchen cabinet.

Note

DO NOT install screw (Fig. 19, 24 / 27) or hinge spacer (Fig. 19, 23 / 26), at top appliance door hinge (Fig. 19, 18) if it interferes with kitchen cabinet door hinge.

- a) Place the appropriate hinge spacer (Fig. 19, 23 / 26) between the appliance door hinge (Fig. 19, 19) and the kitchen cabinet wall or cabinet spacer (Fig. 19, 32):
- For 3/4 in. (19 mm) thick cabinet walls – use small spacer (Fig. 19, 23).
 - For 5/8 in. (16 mm) thick cabinet walls – use large spacer (Fig. 19, 26).
- b) Use the appropriate screws (Fig. 19, 24 / 27) according to the thickness of the kitchen cabinet walls:
- For 3/4 in. (19 mm) thick cabinet walls – use No. 5 x 75 mm screws (Fig. 19, 24).
 - For 5/8 in. (16 mm) thick cabinet walls – use No. 5 x 80 mm screws (Fig. 19, 27).
- c) If you are using a cabinet spacer (Fig. 19, 32) make sure the screws go through the cabinet spacer.

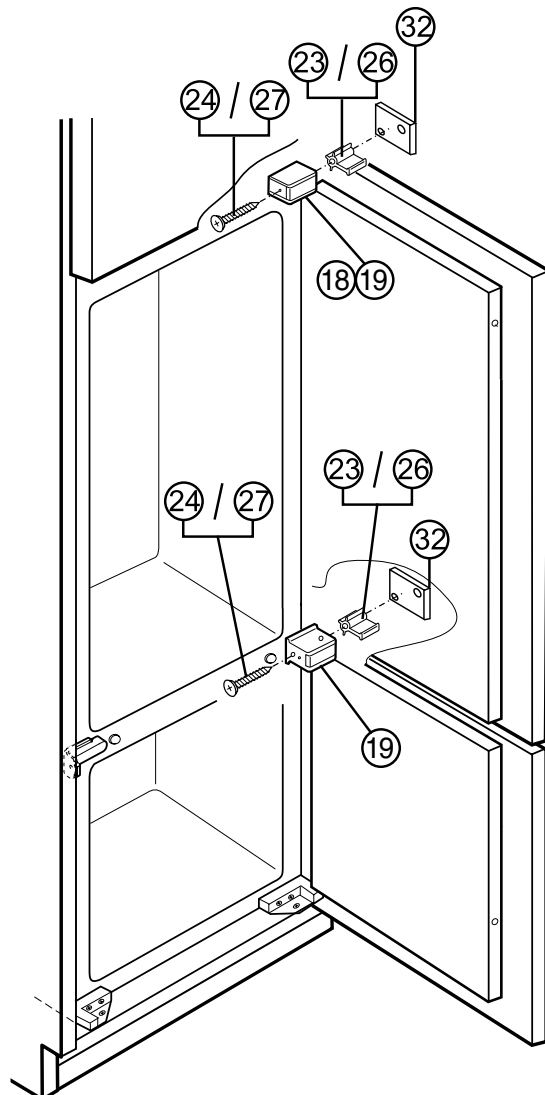

Figure 19

INSTALLATION

7. Attach appliance to the floor of the kitchen cabinet by threading screws (**Fig. 20, 22**) through bottom brackets (**Fig. 20, 12**).

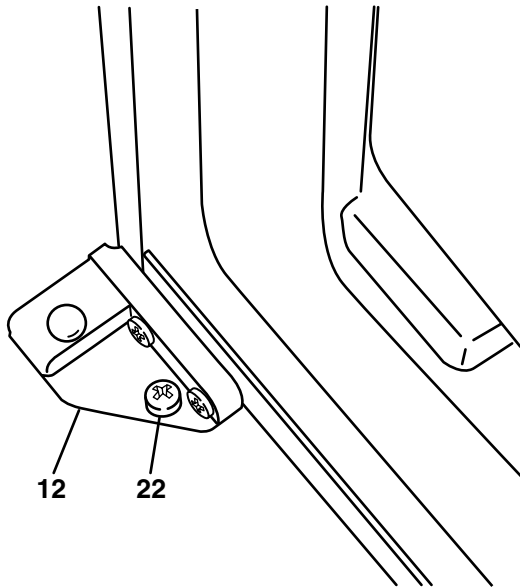

Figure 20

8. Remove the center bracket cover (**Fig. 21, 13**) and then the center bracket (**Fig. 21, 10**).

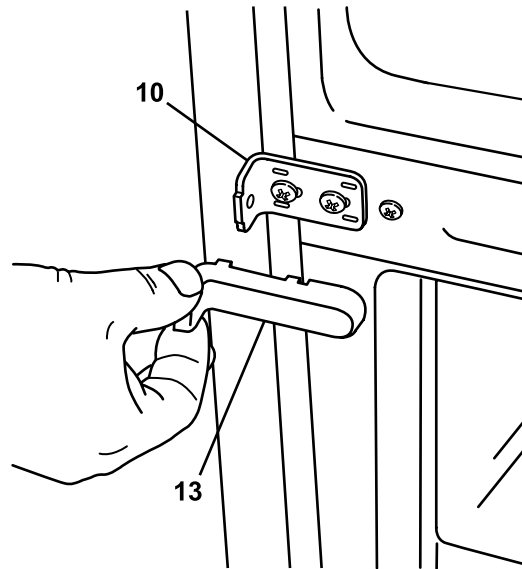

Figure 21

9. Cut sealing strip (**Fig. 22, 25**) to the length of the recess on the handle side of appliance. Press sealing strip into place between appliance and kitchen cabinet wall on handle side of appliance.

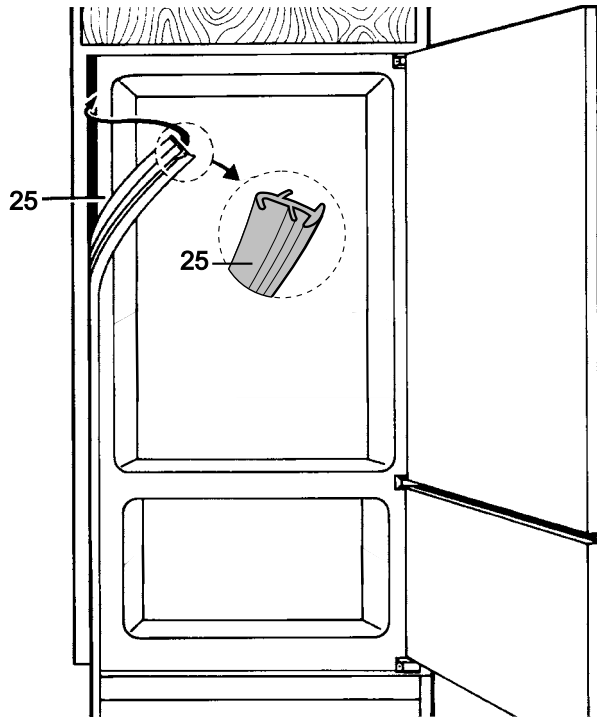

Figure 22

10. Reinstall middle bracket (**Fig. 23, 15**) to appliance. Attach bracket to kitchen cabinet with a screw (**Fig. 23, 22**). Snap cover into place.

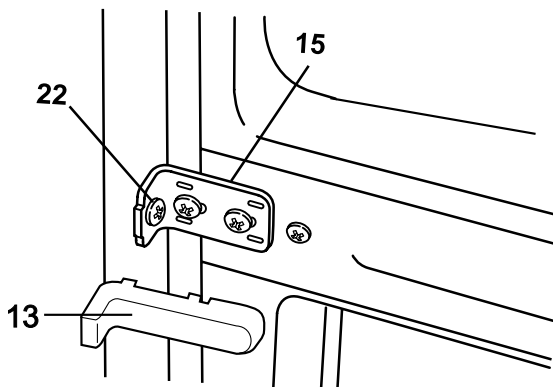

Figure 23

11. Install top bracket (**Fig. 24, 15**) to kitchen cabinet using two screws (**Fig. 24, 22**). Snap cover into place.

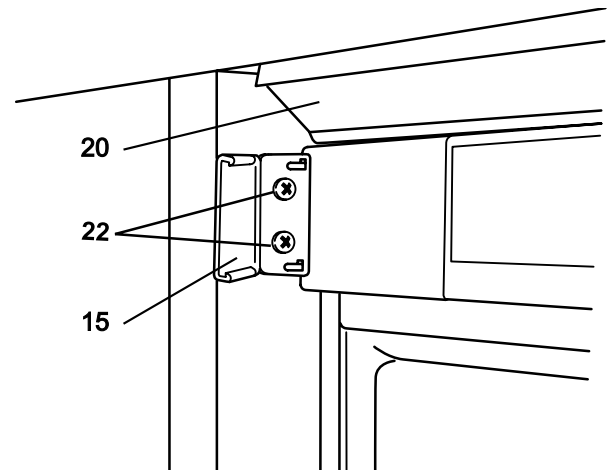

Figure 24

12. Align the equalizer trim (**Fig. 24, 20**) so it is *parallel* with the bottom edge of the top wall of the kitchen cabinet (it must not project beyond this edge).

INSTALLATION

Attaching the Kitchen Cabinet Doors - Figures 25, 26

1. Attach at least one connecting element (Fig. 25, 28) to each appliance door using the screws (Fig. 25, 29) provided. Some large doors may need two connecting elements (Fig. 25, 28) and connecting rails (Fig. 25, 30).
 - a) Use the pre-drilled hole(s) in each appliance door to attach the connecting element(s) (Fig. 25, 28) to the door of the appliance.
 - b) Make sure the connecting elements (Fig. 25, 28) and connecting rails (Fig. 25, 30) do not interfere with the kitchen cabinet door handles.

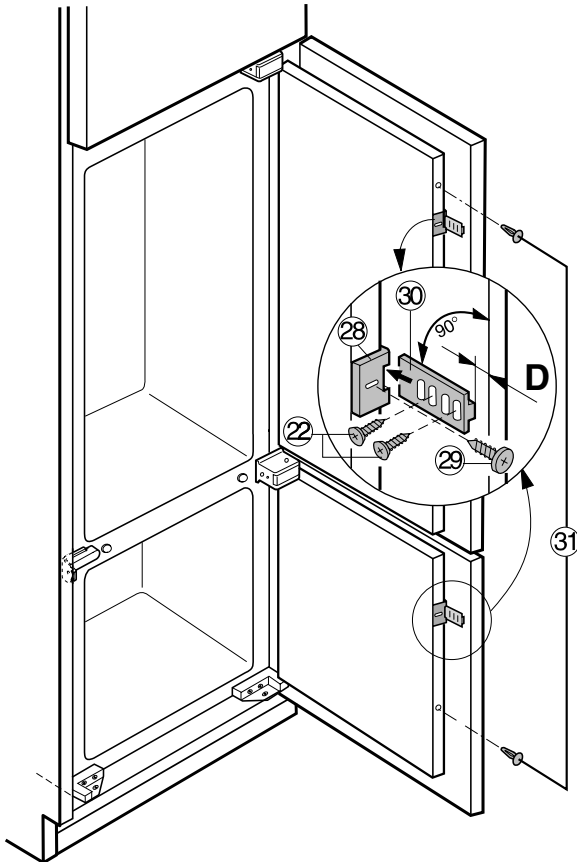

Figure 25

2. Open the kitchen cabinet door completely.
 - a) Slide one connecting rail (Fig. 25, 30) into each connecting element (Fig. 25, 28).
 - b) Attach the connecting rails (Fig. 25, 30) to the kitchen cabinet doors using the screws (Fig. 25, 22) provided.
 - i) Make sure the front edge of each connecting rail is recessed (dimension "D" in Figure 25) from the edge of the kitchen cabinet door.

D = thickness of kitchen cabinet wall + 1/8 in. (3 mm)

 - ii) Make sure the connecting rails (Fig. 25, 30) are parallel to the bottom edge of the kitchen cabinet doors.
3. Adjust the connecting elements (Fig. 25, 28) so there is a 1/32 in. (1 mm) gap (Figure 26) between the door of the kitchen cabinet and the handle side of the kitchen cabinet wall when the door is closed.

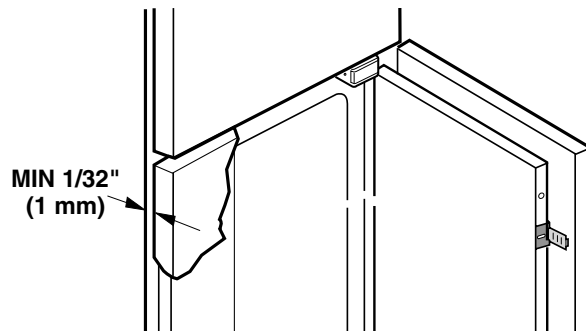

Figure 26

4. Use an awl to open the remaining holes on the front edge of each appliance door. Insert plugs (Fig. 25, 31) into each hole.

CAUTION

To protect the appliance from possible damage, allow the appliance to stand 30 minutes to 1 hour in place before turning the electricity on. This allows the refrigerant and system lubrication to reach equilibrium.

Safety Regulations

The appliance is designed to cool, freeze and store food and to make ice. It is designed as a household appliance. We cannot underwrite a warranty for any other use.

The appliance is set to operate within specific ambient temperature limits according to its climate rating. These temperature limits should not be exceeded. The correct climate rating for your appliance is indicated on the model plate.

This is explained as follows:

Climate Rating	Set for Ambient Temperatures of
SN	50°F to 90°F (10°C to 32°C)
SN-T	50°F to 109°F (10°C to 43°C)
N	61°F to 90°F (16°C to 32°C)
ST	65°F to 100°F (18°C to 38°C)
T	65°F to 109°F (18°C to 43°C)

- The refrigerant circuit has been tested for leaks.
- The appliance complies with current safety regulations UL250 and CSA C22.2 #63.

We recommend cleaning the appliance before turning it on for the first time. See **Cleaning**. Turn on the appliance approximately two hours before loading it with frozen food. Do not load the appliance with frozen food until the temperature shows at least 0°F (-18°C).

WARNING

TIPOVER HAZARD!

- Do not allow children to play with the appliance. Children must not climb, sit or stand on the shelves, drawers or door.
- Failure to follow these instructions could result in death or serious injury.

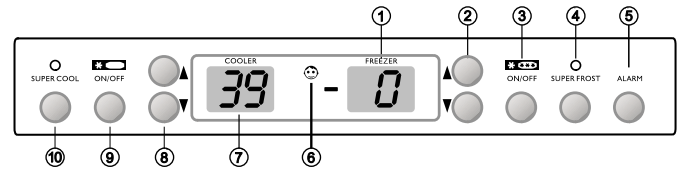

Turning the Appliance ON and OFF - Figure 1

Pressing the main ON/OFF button (Fig. 1, 3) always turns the *entire* appliance, both the refrigerator *and* the freezer compartment, *on or off*.

Turning ON

Press the **ON/OFF Buttons** (Fig. 1, 3 or 9) so that the *temperature displays* (Fig. 1, 1) and (Fig. 1, 7) *light up, flash or display* (---).

- The **refrigerator compartment** is turned on when the *temperature display* (Fig. 1, 7) *is on* and the interior light is operational.

- ON / OFF  The **freezer compartment** is turned on when the *temperature display* (Fig. 1, 1) *is on*. The alarm will sound when the appliance is turned on for the first time and when the appliance is warm. Press the **Alarm Button** (Fig. 1, 5) to turn it off. See **Alarm**.

OPERATION

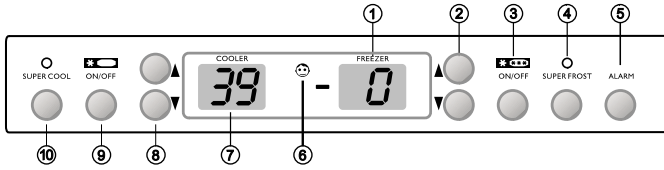

Turning OFF

⚠ WARNING

ELECTRICAL SHOCK HAZARD!



- To prevent possible injury due to an electrical shock, be sure to disconnect the power cord or turn OFF the circuit breaker before replacing the interior light or cleaning the appliance.
- To avoid injury or damage, do not use steam cleaning equipment to clean the appliance.
- Failure to follow these instructions could result in death or serious injury.

Turn off the *entire* appliance with the main **ON/OFF Button (Fig. 1, 3)** so that the temperature displays go out.

Note

If you only want to **switch off the refrigerator compartment** (keeping the freezer compartment switched on; useful when you go on vacation, for example), press the **ON/OFF Button (Fig. 1, 9)**. The refrigerator temperature display (Fig. 1, 7) and the interior light will go out. The freezer temperature display (Fig. 1, 1) must remain on.

Setting the Temperature - Figure 1

The appliance is pre-set for normal operation. We recommend temperatures of 41°F (5°C) in the refrigerator and 0°F (-18°C) in the freezer.

▼ To reduce the temperature:

Press the **Down Refrigerator Temperature Button; (Fig. 1, 8)**. or press the **Down Freezer Temperature Button; (Fig. 1, 2)**.

▲ To increase the temperature:

1. Press the **Up Refrigerator or Freezer Button**. While you are entering the temperature, the set temperature will flash on the display.

2. When you press the temperature setting buttons for the first time, the most recent setting (known as the “reference setting”) is displayed.
3. You can change the settings in increments of approximately 1°F or 1°C by briefly pressing the buttons again. If the buttons are held down the temperature setting will change faster.
4. Approximately five seconds after the button has been released, the display will automatically show the actual freezing or cooling temperature (known as the “actual setting”).
5. You can change the temperatures:
 - In the refrigerator - between 36°F and 45°F (2°C and 7°C) and
 - In the freezer - between 7°F and -15°F (-14°C and -26°C).

Whether you can obtain the lowest temperature depends on where the appliance is positioned (if it is located in an area with a high ambient temperature it may not reach the lowest temperature).

Childproof Lock - Figure 1



The childproof lock is designed to protect the appliance from being turned OFF accidentally.

1. **Turning ON:** Hold down the **Alarm Button (Fig. 1, 5)** and then press the **SuperFrost Button (Fig. 1, 4)**. Keep both buttons pressed simultaneously for approximately three seconds.
 - A double beep confirms your entry.
 - The **Childproof Lock Display (Fig. 1, 6)** will come ON.
2. **Turning OFF:** Press this key combination again; the display (Fig. 1, 6) will now turn off.

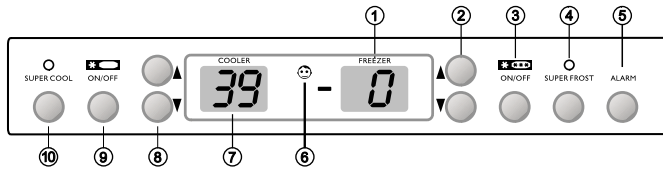

Changing the Temperature Display

The temperature reading can be displayed in either degrees Fahrenheit or degrees Celsius.

When the appliance is first turned on or after a power failure, the refrigerator Temperature Display and Setting Display (**Fig. 1, 7**) will show the set temperature display, either degrees Fahrenheit or degrees Celsius, for five seconds. Then, the actual temperature is displayed.

To change the temperature display:

1. First press and hold the **Alarm Button** (**Fig. 1, 5**) and then additionally the **Down Refrigerator Temperature Button** (**Fig. 1, 8**) for seven seconds. The set temperature display will blink six times.
2. While the temperature display is blinking, hold the **Alarm Button** and use the **Down Refrigerator Temperature Button** to change the temperature display.
3. After making the change, the new temperature display will blink six times. Then both temperature displays will show the actual temperature value.

39

Temperature Display - Figure 1

In normal operation, the following settings will be displayed:

- The average refrigerator temperature in display (**Fig. 1, 7**)
- The warmest frozen food temperature in display (**Fig. 1, 1**).

When starting up for the first time or when the appliance is warm, dashes will appear until the temperature reaches a level that can be displayed; 32°F to 60°F (0°C to 19°C) in the refrigerator and below 32°F (0°C) in the freezer.

It will take between three and eight hours for the required temperature, 0°F or 39°F (-18°C or 4°C), to be reached and displayed permanently in the display, depending on the ambient conditions and the temperature setting.

The display will “flash:”

- If you change the temperature or
- If the temperature rises by several degrees, indicating cold loss, e.g. if you place fresh, “warm” food in the freezer or if you remove or repack frozen food, the temperature may rise for a short time due to warm air flowing into the freezer. Once you have finished loading or repacking, the electronics will automatically reset the temperature to the most recent setting. Short-term rises in temperature will not affect the frozen food.

If “F0” to “F5” appears in the display, the appliance has a fault. Have the fault number available when you contact the customer service department. See **Customer Service**.

Display Brightness - Figure 1

Your appliance is delivered with the display brightness set to low.

When the door is opened or the temperature settings are changed, the display automatically switches to bright for one minute, or as long as the alarm state lasts. You can change the brightness if required.

- **To make display brighter:** Keep the **Alarm Button** pressed while simultaneously pressing the **Up Freezer Temperature Button** (**Fig. 1, 2**).
- **To make display darker:** Keep the **Alarm Button** pressed while simultaneously pressing the **Down Freezer Temperature Button** (**Fig. 1, 2**).

OPERATION

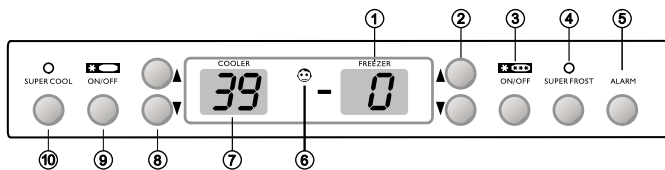

Alarm - Figure 1

The alarm helps to protect frozen food and to save energy.

- The audible warning device is turned OFF by pressing the **Alarm Button (Fig. 1, 5)**.
- It turns OFF automatically as soon as the temperature is low enough.

Audible door alarm

- This sounds when the door has been left open for longer than about 60 seconds.
- The sound switch-OFF function is active as long as the door is left open.
- The alarm automatically switches back to standby when the door is shut.

Audible / visual temperature alarm

- It always sounds if the freezer temperature is not low enough (dependent on the temperature setting).
- The temperature display flashes at the same time. This can be caused by:
 - warm, fresh food being placed in the freezer,
 - too much warm air from the outside entering when rearranging or removing frozen food.

The temperature display will continue to “flash” until the cause of the alarm has been rectified. It will then stop flashing and light up continually. The alarm is now automatically reset.

Power Failure / FrostControl Display - Figure 1

nR If **nR** appears in the display, this means the freezer temperature has risen too **high** during the last few hours or days due to a power failure.

Once the power is back on, the appliance will continue to operate at the most recent temperature setting.

- If you press the **Alarm Button (Fig. 1, 5)** while the display is reading **nR**, the highest temperature registered during the power failure will be displayed.
- Check the quality of the food in case it has become too warm or even defrosted.
- The highest temperature will appear for approximately one minute. After that, the actual temperature in the freezer will reappear.
- The **nR** in the display will disappear once the **Alarm Button** is pressed again.

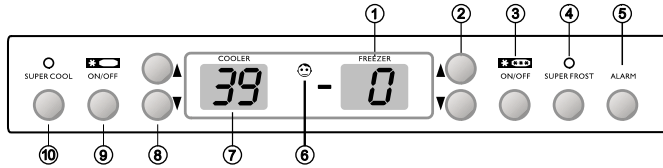

Cooling with Fan - Figure 1



Cooling with the fan generates relatively even temperatures on all of the shelves. All food will be chilled to the same relevant temperature, which you can select. The forced air circulation ensures that the temperature is relatively the same in all areas of the refrigerator.

As a rule this is recommended:

- in high room temperatures, approximately 95°F (35°C) or higher and
- if the air humidity is high, e.g. during the summer.

Turning ON/OFF: Press fan switch (Fig. 1, 11).

= ON, 0 = OFF.

Note

- The energy consumption will increase when the fan is turned ON.
- To save energy, the fan will turn OFF automatically when the door is open.

SuperCooling - Figure 1



The **SuperCooling Button (Fig. 1, 10)** switches the refrigerator compartment to maximum cooling. It is recommended particularly if you wish to cool large quantities of food, drinks, freshly baked goods or meals rapidly.

- **Turning ON:** Press the **SuperCooling Button (Fig. 1, 10)** briefly so it lights up. The refrigerator temperature will drop to its lowest value (dependent on the room temperature).

Note

The SuperCooling function uses slightly more energy. After approximately six hours, however, the refrigerator switches back automatically to normal energy-saving operation. If required, the SuperCooling function can be turned OFF sooner.

- **Turning OFF:** Press the **SuperCooling Button (Fig. 1, 10)** again until it goes out.

REFRIGERATOR COMPARTMENT

Arranging Food - Figure 27

When the fan is off, the natural circulation of air in the refrigerator compartment results in different temperatures in different parts of the refrigerator. The refrigerator is coldest just above the vegetable bins and near the rear wall (best for sausage and meat products); it is warmest at the front, at the top and in the door (best for spreadable butter, cheese, etc.). **Do not put food against the rear wall; the food could freeze.**

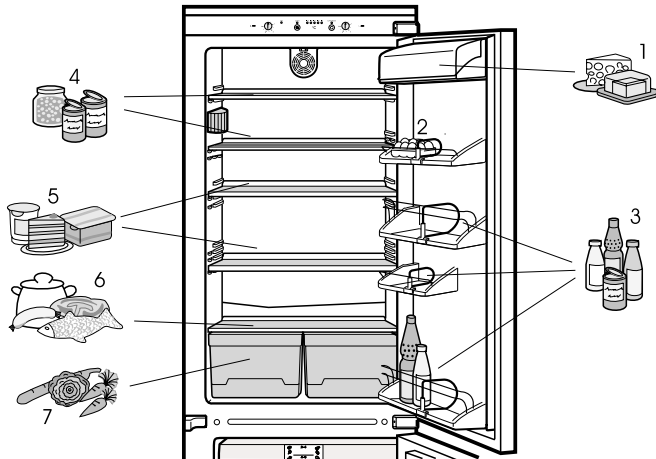

- (1) butter, cheese
- (2) eggs
- (3) cans, drinks, bottles
- (4) preserves
- (5) dairy products, baked goods, drinks
- (6) raw meat, cold meats, fish, pre-cooked meals
- (7) fruit, vegetables, salad

Figure 27

Notes

- Store food so air can circulate properly around it. Do not pack the refrigerator too full.
- Liquids and food which give off or absorb odors and flavors should always be stored covered or in closed containers.
- Always store food which gives off or is sensitive to ethylene gases such as fruit, vegetables and salads separately or wrapped in order not to affect their storage life. For example, do not store tomatoes together with kiwis or cabbage.

Shelf Arrangement

CAUTION

LACERATION HAZARD!

- To avoid possible injury, only adjust an empty shelf. Do not attempt to adjust a shelf with food on it.
- Failure to follow these instructions may result in minor or moderate injury.

You can rearrange the height of the shelves and door racks as required.

Repositioning the door racks - Figure 28

Empty the door rack, slide the door rack up, pull out toward you and replace in reverse order.

Adjusting the bottle holder

You can protect the bottles from falling over when the door is opened and closed. Always hold by the plastic handle.

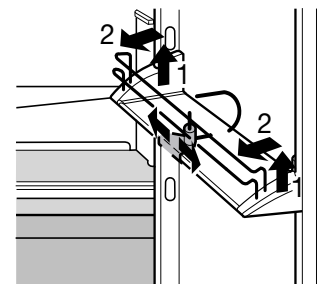

Figure 28

REFRIGERATOR COMPARTMENT

Repositioning the shelves - *Figure 29*

- Empty the shelf, lift the shelf, slide forward and remove.
Always insert shelves with the raised edge at the back pointing up, otherwise food may freeze onto the rear wall.
- The glass shelves are fitted with stops to prevent them from being pulled out accidentally.

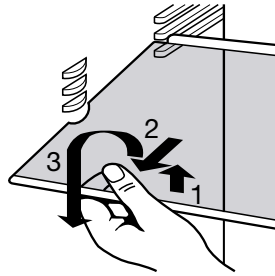

Figure 29

If you need space for large bottles and containers - *Figure 30*

Lift the front half of the split glass shelf and carefully slide it under the back half until the stops click into the recesses.

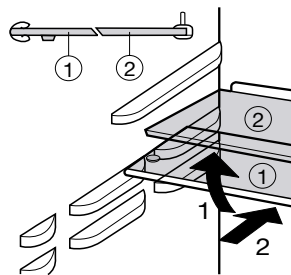

Figure 30

Interior Light

This turns OFF automatically after the door has been opened for approximately 15 minutes. If it does not turn ON when the door is opened briefly, but the temperature display is working, the bulb may be defective.

Replacing the bulb:

⚠ WARNING

ELECTRICAL SHOCK HAZARD!

- To prevent possible injury due to an electrical shock, be sure to disconnect the power cord or turn OFF the circuit breaker before replacing the interior light or cleaning the appliance.
- Failure to follow these instructions could result in death or serious injury.

⚠ CAUTION

LACERATION HAZARD!

- To prevent possible injury due to broken glass, use hand protection when replacing the interior light.
- Failure to follow these instructions may result in minor or moderate injury.

1. **Bulb data:** Only use bulbs of the same size and 25 W maximum. Current and voltage must agree with the details on the model plate.

2. Press the light cover together at the sides (**Fig. 31, 1**). Lift it out and unclip at back (**Fig. 31, 2**).

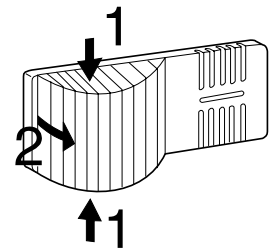

Figure 31

3. Replace the bulb (**Figure 32**).
4. Clip the back end of the cover in and clip the sides into place.

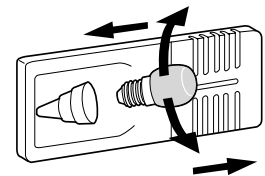

Figure 32

A delight in freshness

FREEZER COMPARTMENT

SuperFrost - Figure 1

Fresh food should be frozen completely and as rapidly as possible. Frozen food can also be given a cold boost. This is provided by the SuperFrost feature and ensures that the nutritional value, appearance and flavor of the food remain intact.

- The maximum amount of food which can be frozen in 24 hours is shown on the model plate ("Freezing capacity ... kg/24h"), (Fig. 1, 30). This amount varies according to the model and climate rating.

Freezing with SuperFrost - Figure 1

Press the **SuperFrost Button** (Fig. 1, 4) briefly so it lights up. The freezer temperature will decrease and the appliance will change to the lowest temperature.



For small amounts of frozen food, it is normally sufficient to turn ON SuperFrost six hours beforehand. For the **maximum** amount (see freezing capacity on the model plate) you will need to turn it ON 24 hours before.

- Then place the fresh food inside the freezer, preferably in the top drawers.

If freezing the maximum quantity of food, do not use the drawers. Place the wrapped food directly on the shelves. Once the food is frozen, load it into the drawers.

- The SuperFrost function turns OFF automatically. Depending on the quantity of food placed in the freezer, this will normally be between 30 hours and a maximum of 65 hours. The freezing process is now complete, the SuperFrost LED will go out and the freezer will switch back to normal energy-saving operation.

Note

You do not have to turn ON the SuperFrost function:

- When placing frozen food in the freezer.
- When freezing up to approximately 4-1/2 lbs (2 kg) fresh food daily.

Freezing and Storage

Do Not Freeze:

Lettuce, radishes, grapes, whole apples, pears and fatty meat.

Food to Freeze:

Meat, game, poultry, fresh fish, vegetables, fruit, dairy products, bread, baked goods, pre-cooked meals.

- Pack frozen food in standard freezer bags or reusable plastic, metal or aluminum containers.
- Do not allow fresh food which is to be frozen to come into contact with food already frozen. Always keep packages dry in order to avoid them sticking together.
- Always write the date and contents on the package and do not exceed the stated storage time for the food. This prevents spoiling.
- Pack food which you are freezing yourself in quantities right for your household. To ensure the food freezes completely and quickly, the following quantities should not be exceeded per package:
 - fruit, vegetables: up to 2-1/4 lbs (1 kg);
 - meat: up to 5-1/2 lbs (2.5 kg).
- Blanch **vegetables** after washing and cutting them. (Add to boiling water for 2-3 minutes, remove and quickly cool down in cold water. If you blanch with a steamer or microwave oven, please follow the operating instructions.)
- Do not salt or season fresh food or blanched vegetables before freezing. Only lightly salt and season other food. Some spices can alter their flavor intensity.
- Do not freeze bottles and cans as they might burst. Drinks can be cooled down quickly, but take the bottles or cans out of the freezer compartment after an hour at the most.

FREEZER COMPARTMENT

Storage

Each drawer and shelf can take up to 55 lbs (25 kg) frozen food. By removing the 2nd and 3rd drawers and the shelf you can create a double-height space for large frozen food items. This enables you to freeze such things as poultry, large pieces of meat or large cakes without first having to cut them up, so they can be served “whole” afterwards.

If you want to use the maximum net-capacity, you can remove the drawers and store items directly on the shelves.

- Always leave the bottom drawer in the appliance.
- If you have removed the top drawer, *do not* cover the fan slits at the back, otherwise the freezer will not work properly.

Removing Drawers - Figure 33 and 34

CAUTION

LACERATION HAZARD!

- To avoid possible injury, only adjust an empty shelf. Do not attempt to adjust a shelf with food on it.
- Failure to follow these instructions may result in minor or moderate injury.

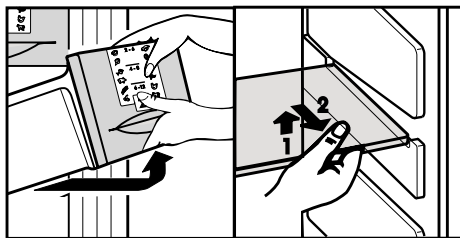

Figure 33

Figure 34

- Removing drawers (Figure 33): Pull forward until the drawer stops and lift out.

- Removing the shelf (Figure 34): Remove the 2nd and 3rd drawers. Lift the front edge of the shelf up and pull it out.

To insert: simply slide shelf in and allow the front edge to click into place.

- Always store identical food items together to avoid the door being open for unnecessarily long periods and to save energy.
- Do not exceed storage times given.

Thawing

WARNING

POISONING HAZARD!

- Do not attempt to re-freeze any thawed, previously frozen food.
- Failure to follow these instructions could result in death or serious injury.

Only take out as much food as is needed for thawing. Cook food which has been thawed as quickly as possible. Frozen food can be thawed in the following ways:

- in a microwave oven
- in the refrigerator: the safer way to thaw food because there is less chance of bacteria growth and it saves energy. Use this method for high density food such as roasts or poultry.
- Flat portions of meat or fish can be cooked when partially thawed.
- Vegetables can be cooked from frozen (in half the normal time).

FREEZER COMPARTMENT

Freezer Tray - Figure 35

The freezer tray is used for gently freezing berries, herbs, vegetables and other small items and prevents them from sticking together. Items being frozen will largely retain their shape, and it will be easier to remove exactly the right quantity later on.

- Spread the items out loosely on the tray.
- Suspend the freezer tray in one of the top drawers. Freeze for 10 to 12 hours, then transfer to a freezer bag or container and put in a drawer.
- To defrost, spread the frozen items out loosely.

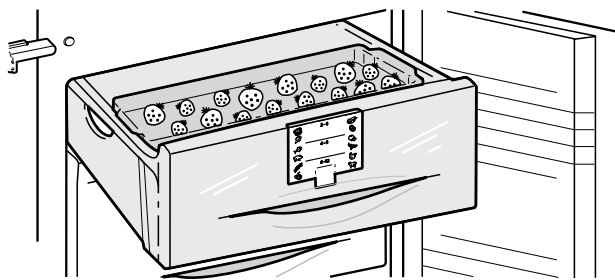

Figure 35

Information System - Figure 37

Use frozen food within the recommended period. The numbers between the symbols indicate the storage period in months for different kinds of frozen foods. Storage times given are guidelines for food frozen at home. Whether or not the lower or upper value is applicable depends on the food quality and how it was processed prior to freezing. The lower values always apply to food with a high fat content.

pre-cooked meals		2 - 6		sausages
ice-cream				bread
fish		4 - 8		mushrooms
pork				game
vegetables		6 - 12		poultry
fruit				beef/veal
		2		

Figure 37

Making Ice Cubes - Figure 38

Appliances without IceMaker

1. Fill the ice cube tray with water.
2. Place the ice cube tray in the appliance and leave it to freeze.
3. Remove the ice cubes from the tray by twisting the tray or holding it upside down for a short time under running water.

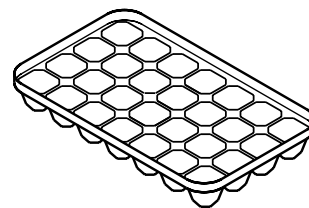

Figure 38

FREEZER COMPARTMENT

To Start the IceMaker - Figure 39

The IceMaker will only work if the combined refrigerator-freezer is connected to the electrical outlet. It will only make ice cubes if the freezer compartment is operating and if the minimum freezer temperature is 14°F (-10°C).

The IceMaker is in the top left drawer in the freezer compartment of the combined refrigerator-freezer. You can identify this drawer by its labeling "IceMaker."

To turn ON

- Pull out the drawer.
- Press the "ON/OFF" button so the control lamp comes on (**Figure 39**).
- Close the drawer.

Note

The IceMaker can only make ice cubes if the drawer is completely closed.

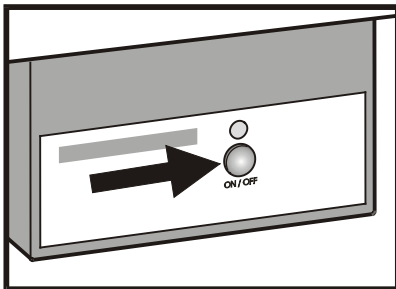

Figure 39

To turn OFF

If you do not need any ice cubes, the IceMaker can be turned off independently of the freezer compartment.

- Press the "ON/OFF" button for approximately 1 second so the control lamp goes out.

Note

If the IceMaker is turned off, the empty drawer can also be used to freeze and store food.

To make ice cubes

After you start the icemaker for the first time it may take up to 24 hours before the first ice cubes are ready.

Note

The first three batches of ice must not be consumed or used. This will help ensure that the water supply lines are free of contaminants.

The production capacity depends on the temperature inside the freezer compartment. The lower the temperature, the more ice can be produced over a period of time.

The ice cubes fall out of the icemaker into the drawer. When the ice reaches a certain level in the drawer, the appliance stops producing ice automatically.

If you need a large quantity of ice you can change out the drawer to the right with the complete "Ice-Maker" drawer. When you close the drawer the icemaker will immediately start production.

FREEZER COMPARTMENT

To Clean the IceMaker - *Figure 40*

The IceMaker (arrow in **Figure 40**) can be cleaned by using this procedure.

1. Pull out the drawer and remove the ice.
2. Clean the drawer with warm water and mild dish detergent.
3. To access the IceMaker for cleaning:
 - a. With the drawer pulled out, press and hold the "ON/OFF" button until the LED goes out (takes about 1 second).
 - b. Continue to hold the button and after 10 seconds the LED will start to flash.
 - c. Insert the drawer while the LED is flashing. The IceMaker should rotate down into the cleaning position.
 - d. Remove the drawer.

4. Clean the IceMaker with warm water. If you need to use a cleaning aid, use a mild dish detergent and rinse. **You will need to throw out the first three batches of ice if you use any soap.**
5. Push the "ON/OFF" button until the LED lights and insert the drawer.
6. **Throw out the first three batches of ice to remove any soap residue.**

Note

If you need to leave the IceMaker off, clean the IceMaker but do not push the "ON/OFF" button in Step 5.

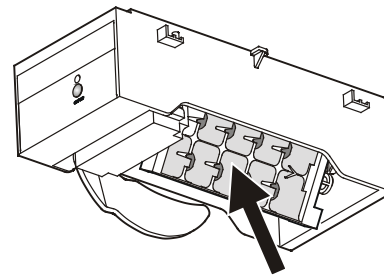

Figure 40

Notes on Defrosting

The NoFrost system **automatically** defrosts the appliance.

In the refrigerator compartment

The water that forms on the rear wall drains into an evaporation container at the back of the appliance and evaporates automatically through the compressor heat. Drops of water, or frozen drops of water, on the rear wall are perfectly normal. Ensure that the defrost water can flow freely through the defrost drain hole (**Fig. 1, 17**) in the rear wall (**arrow in Fig. 1**).

In the freezer compartment

Any moisture arising collects on the evaporator and freezes, and is periodically defrosted and evaporated. The automatic defrosting system keeps the freezer frost-free and eliminates the time and effort spent on defrosting manually.

Cleaning

WARNING



ELECTRICAL SHOCK HAZARD!

- To prevent possible injury due to an electrical shock, be sure to disconnect the power cord or turn OFF the circuit breaker before replacing the interior light or cleaning the appliance.
- To avoid injury or damage, do not use steam cleaning equipment to clean the appliance.
- Failure to follow these instructions could result in death or serious injury.

Clean the inside and equipment by hand with lukewarm water and a little detergent.

DO NOT use abrasive or scouring sponges. Do not use concentrated cleaning agents and never use abrasive or acid cleaners or chemical solvents.

- We recommend using a soft cloth and an all-purpose cleaner with a neutral pH value. Only use food compatible cleaning and care agents on the inside of the appliance.

- We recommend treating stainless steel appliances with a special stainless steel cleaning agent after normal cleaning.
- Do not allow cleaning water to run down the drain gully or to penetrate the ventilation grilles or electrical components. Dry the appliance.
- Do not damage or remove the model plate on the inside of the appliance (**Fig. 1A**). It is very important for servicing purposes.
- The butter dish can be washed in a dishwasher. The racks, shelves and other components should be cleaned by hand.
- The shelves and door racks can be dismantled for cleaning (**Figure 41**).
- Remove the trim and sides from the glass shelves.
- Remove all protective film from the decorative trim.
- Clean the drain hole (**Fig. 1, 17**) in the rear wall (**arrow in Fig. 1**) frequently. If necessary, clean with a thin object such as a cotton swab.
- Then connect and turn ON the appliance and wait until the temperature reaches the set value before adding food. See **Turning the Appliance ON and OFF**.

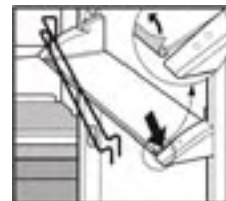

Figure 41

If the appliance is to be **left turned OFF for any length of time**, empty the appliance, disconnect from the power source, clean as described above and leave the door open so as to avoid odors.

Energy Saving Tips

- Ensure there is adequate space around the appliance for ventilation and air extraction.
- Avoid keeping the door open for too long.
- Store food logically. Do not exceed the storage period specified.
- Make sure to allow hot food to cool to room temperature before placing in the appliance.
- Keep the appliance door shut in the event of a breakdown. This will delay the cold loss and will help to maintain the quality of the frozen food longer.

TROUBLESHOOTING

Your appliance is designed and manufactured for a long life and reliable operation.

that even during the warranty period, some repair costs may be your responsibility.

If a problem occurs during operation, check whether it is due to an operating error. Please note

You may be able to correct the following faults by checking the possible causes yourself:

Problem	Possible Cause and Remedy
Appliance does not work, display is OFF	<ul style="list-style-type: none">- Is the appliance turned ON properly?- Is the power source plug properly inserted in the socket?- Is the circuit breaker or fuse in operating condition?
The interior light does not come ON	<ul style="list-style-type: none">- Is the refrigerator compartment turned ON?- Has the door been open for more than 15 minutes?- The bulb is defective. Change the bulb as described in Interior light.
Loud running noise	<ul style="list-style-type: none">- Is the appliance standing firmly on the floor, or does the compressor cause nearby items of furniture or objects to vibrate? If necessary, move bottles and containers apart.- Bubbling noises are normal. These are caused by the refrigerant flowing around the refrigerant circuit.- A short clicking sound: This will be heard whenever the compressor turns ON or OFF automatically.- Motor noise: This will be slightly louder for a brief period when the compressor turns ON. The refrigerating capacity will increase when the SuperFrost function is activated, fresh food has just been placed in the appliance or the door has been left open for a while. A low-pitched humming sound is caused by air flow noises in the fan.
The compressor continues to run for a long time	On energy saving models, this is perfectly normal. When less refrigeration is required, the VCC compressor switches to a low speed. It will run almost constantly, but it still saves energy.
<ul style="list-style-type: none">- The alarm sounds,- the temperature is not cold enough	<ul style="list-style-type: none">- Have you put too much fresh food into the freezer without activating SuperFrost? See SuperFrost.- Does the door close properly?- Is the appliance sufficiently ventilated? Clean ventilation grilles if necessary.- Is the ambient temperature too hot? See Safety Regulations.- Has the appliance been opened too often or left open too long?- If applicable, wait until the appliance reaches the required temperature itself.
<i>nA</i> appears in the display	There has been a power failure; proceed as described in Power Failure/FrostControl Display .
IceMaker is not making any ice.	<ul style="list-style-type: none">- Is the IceMaker turned on?- Is the water supply line open?- Is the IceMaker drawer closed properly?

Customer Service - Figure 1



If your refrigerator is not working properly, or if the temperature display reads "F0" to "F5", this means there is a fault. Please contact your nearest customer service department.

Give the **fault number displayed**, together with the

- **Type Designation (Fig. 1, 27),**
- **Service Number (Fig. 1, 28) and**
- **Appliance / Serial Number (Fig. 1, 29)**

as given on the model plate, to ensure prompt, accurate servicing. The model plate is located inside the appliance on the left-hand side.

Leave the appliance closed until the customer service engineer arrives to prevent any further cold loss.

Appliance Information

Record this information when the appliance is installed.

Type Designation: _____

Service Number: _____

Appliance / Serial Number: _____

Date of Purchase: _____

Where Purchased: _____

For Service and Parts in the U.S.:

Liebherr Service Center

15545 N. 77th Street
Scottsdale, AZ 85260
Phone: (480) 998-0141
Fax: (480) 998-7877
Toll Free: **1-866-LIEBHERR** or
1-866-543-2437

E-mail: Liebherr@adcoservice.com

For Service and Parts in Canada:

EURO-LINE APPLIANCES

2150 Winston Park Drive - Unit 20
Oakville, Ontario, L6H 5V1
Phone: (905) 829-3980
Fax: (905) 829-3985
Toll Free: **1-888-LIEBHERR** or
1-888-543-2437

www.euro-parts.ca

A delight in freshness

LIEBHERR WARRANTY PLAN

FULL TWO YEAR WARRANTY - For two years from the date of original purchase, your Liebherr warranty covers all parts and labor to repair or replace any part of the product which proves to be defective in materials or workmanship.

FULL FIVE YEAR WARRANTY - For five years from the date of original purchase, your Liebherr warranty covers all parts and labor to repair or replace any components that prove to be defective in materials or workmanship in the sealed system. The "Sealed System" means only the compressor, condenser, evaporator, drier and all connecting tubing.

LIMITED 6TH THROUGH 12TH YEAR WARRANTY - From the 6th through 12th year from the date of original purchase, your Liebherr warranty covers all parts that prove to be defective in materials or workmanship in the Sealed System (parts only).

TERMS APPLICABLE TO EACH WARRANTY

All service provided by Liebherr under the warranty must be performed by authorized Liebherr service representatives, unless otherwise specified by Liebherr. Service will be provided in the home during normal business hours. This warranty applies only to products installed for normal residential use. Details regarding a non-residential warranty are available on request.

The warranty applies only to products installed in Canada and any one of the fifty states of the United States or the District of Columbia. This warranty does not cover any parts or labor to correct any defect caused by negligence, accident or improper use, maintenance, installation, service or repair, including but not limited to improper removal and reinstallation of the condensing unit.

The remedies described above for each warranty are the only ones which Liebherr will provide, either under these warranties or under any warranty arising by operation of law. Liebherr will not be responsible for any consequential or incidental damages arising from the breach of these warranties or any other warranties, whether express, implied or statutory.

Some states do not allow the exclusion or limitation of incidental or consequential damages so the above limitation or exclusion may not apply to you. This warranty gives you specific legal rights and you may also have other rights which vary from state to state.

To receive parts and/or service and the name of the Liebherr authorized service representative nearest you, contact your Liebherr dealer or distributor or contact the Liebherr designated national service provider:

US: Liebherr@adcoservice.com, or call 1-866-LIEBHERR or 1-866-543-2437

Canada: www.euro-parts.ca, or call 1-888-LIEBHERR or 1-888-543-2437.