



LG

<http://biz.lgservice.com>

SXS REFRIGERATOR **SERVICE MANUAL**

CAUTION

**PLEASE READ THE SAFETY PRECAUTIONS OF THIS MANUAL CAREFULLY
BEFORE REPAIRING OR OPERATING THE REFRIGERATOR**

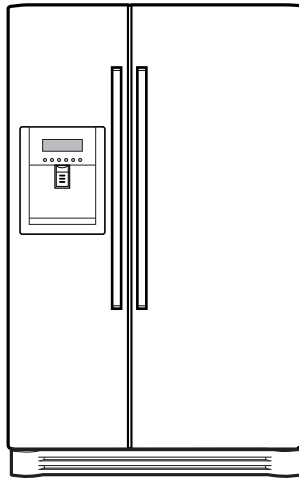

MODEL: LSC26905TT

**COLOR: STAINLESS
WESTERN BLACK
STAINLESS
TITANIUM
NEO TITANIUM**

CONTENTS

WARNINGS AND PRECAUTIONS FOR SAFETY	3
SPECIFICATIONS.....	4
PARTS IDENTIFICATION	7
HOW TO INSTALL THE REFRIGERATOR	11
HOW TO ADJUST THE DOOR HEIGHT.....	11
FILTER	12
HOW TO CONTROL THE ICEMAKER WATER SUPPLY.....	14
MICOM FUNCTION	16
EXPLANATION OF MICOM CIRCUIT	32
EXPLANATION OF PWB CIRCUIT	32
PWB PARTS DIAGRAM AND LIST	59
PWB CIRCUIT DIAGRAM	79
ICEMAKER AND DISPENSER WORKING PRINCIPLES AND REPAIR	87
WORKING PRINCIPLES.....	87
FUNCTION OF ICEMAKER	88
ICEMAKER TROUBLESHOOTING.....	91
ICEMAKER CIRCUIT	92
CIRCUIT	94
TROUBLE DIAGNOSIS.....	98
TROUBLESHOOTING	98
FAULTS	108
SEALED SYSTEM REPAIR	125
HOW TO DEAL WITH CLAIMS.....	132
HOW TO DISASSEMBLE AND ASSEMBLE	137
DOOR.....	137
HANDLE	138
FAN SHROUD GRILLE	139
ICEMAKER ASSEMBLY.....	139
WATER-VALVE DISASSEMBLY METHOD	140
FAN AND FAN MOTOR DISASSEMBLY METHOD	140
DISPENSER.....	141
EXPLODED VIEW	143
REPLACEMENT PARTS LIST	166

WARNINGS AND PRECAUTIONS FOR SAFETY

Please observe the following safety precautions to use the refrigerator safely and correctly and to prevent accident or injury when servicing.

1. Be careful of an electric shock. Disconnect power cord from wall outlet and wait for more than three minutes before replacing PWB parts. Shut off the power whenever replacing and repairing electric components.
2. When connecting power cord, wait for more than five minutes after power cord was disconnected from the wall outlet.
3. Check if the power plug or cord is pinched between the refrigerator and the wall. If the cord is damaged, it could cause fire or electric shock.
4. If the wall outlet is overloaded, it may cause a fire. Use a dedicated circuit for the refrigerator.
5. Be sure the outlet is grounded, This is particularly important in wet or damp areas.
6. Use standard electrical components.
7. Make sure hooks are correctly engaged. Remove dust and foreign materials from the housing and connecting parts.
8. Do not fray, damage, run over, kink, bend, pull out, or twist the power cord.
9. Please check for evidence of moisture intrusion in the electrical components. Replace the parts or mask with insulation tape if moisture intrusion was confirmed.
10. Do not touch the icemaker with hands or tools to confirm the operation of geared motor.
11. Do not suggest that customers repair their refrigerator themselves. This work requires special tools and knowledge. Non-professionals could cause fire, injury, or damage to the product.
12. Do not store flammable materials such as ether, benzene, alcohol, chemicals, gas, or medicine in the refrigerator.
13. Do not put anything on top of the refrigerator, especially something containing water, like a vase.
14. Do not put glass bottles full of water into the freezer. The contents will freeze and break the glass period.
15. When you scrap or discard the refrigerator, remove the doors and dispose of it where children are not likely to play in or around it.

SPECIFICATIONS

3. Ref No. :LSC26905TT (Refer to appendix)

ITEMS	SPECIFICATIONS	ITEMS	SPECIFICATIONS
DIMENSIONS	908 x 896 x 1771 mm	DRIER	MOLECULAR SIEVE XH-7
W x D x H	(35 ¹¹ / ₁₆ X35 ⁵ / ₁₆ X69 ¹¹ / ₁₆ in.)	CAPILLARY TUBE	ID Ø0.83
NET WEIGHT	130 kg (286.6 lbs.)	FIRST DEFROST	4 - 5 Hours
COOLING SYSTEM	Fan Cooling	DEFROST CYCLE	13 - 15 Hours
TEMPERATURE CONTROL	Micom Control	DEFROSTING DEVICE	Heater, Sheath
DEFROSTING SYSTEM	Full Automatic	ANTI-SWEAT HEATER	Dispenser Duct Door Heater
	Heater Defrost		Dispenser Heater
INSULATION	Cyclo-Pentane	ANTI-FREEZING HEATER	Water Tank Heater
			Damper Heater
COMPRESSOR	PTC Starting Type	FREEZER LAMP	40W (1 EA)
EVAPORATOR	Fin Tube Type	REFRIGERATOR LAMP	40W (2 EA)
CONDENSER	Wire Condenser	DISPENSER LAMP	15W (1 EA)
REFRIGERANT	R134a (185g) (6 ¹ / ₂ oz.)		
LUBRICATING OIL	FREOL @ 10G (320 cc)		

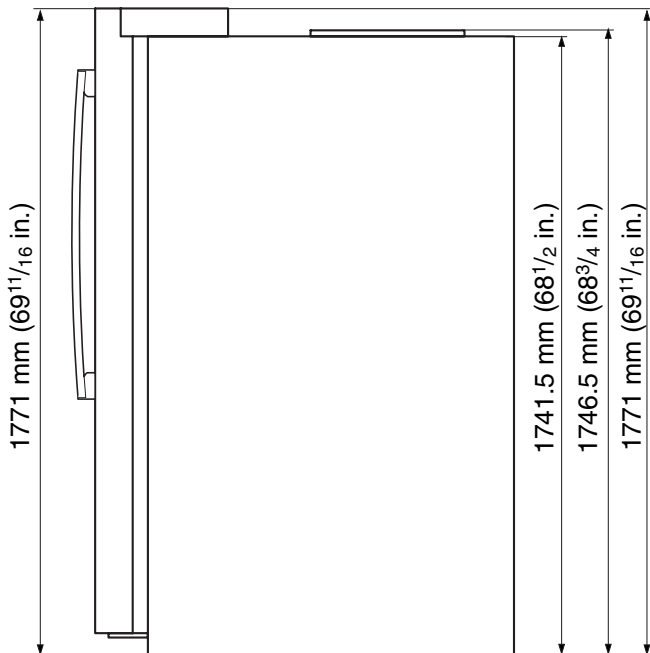

Front View

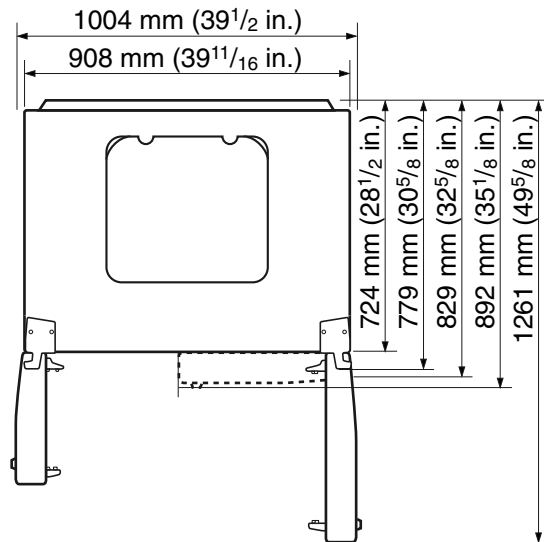

Top View

HOW TO INSTALL THE REFRIGERATOR

1. How to adjust the Refrigerator Door Height

- Make the refrigerator level first. (If the refrigerator is not installed on a flat floor, the height of freezer and refrigerator door may not be the same.)

1. If the freezer door is lower than the refrigerator door:

2. If the freezer door is higher than the refrigerator door:

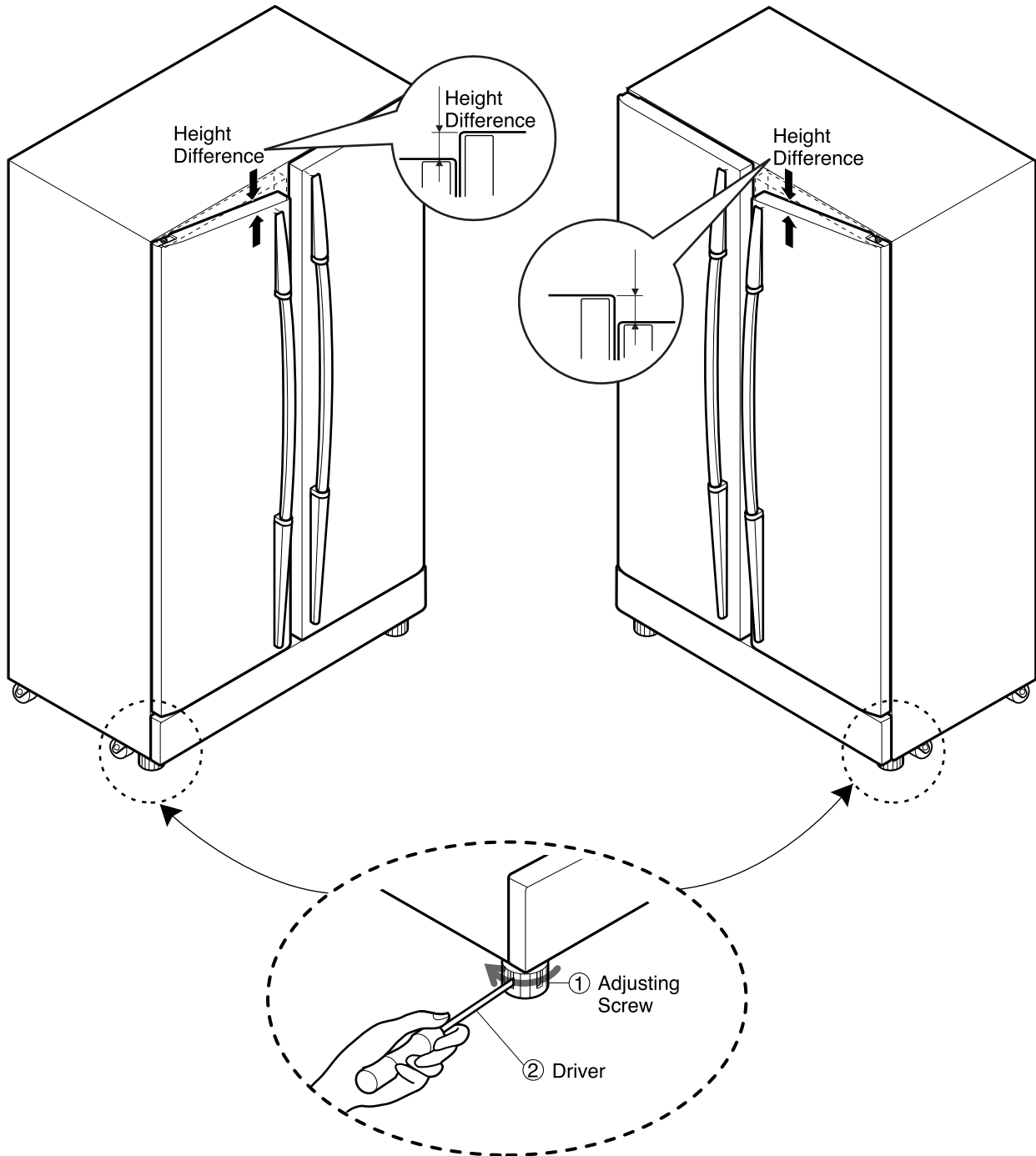

Insert a driver ② into the groove ① if the adjusting screw and turn in the direction of the arrow (clockwise) until the refrigerator is level.

HOW TO INSTALL THE REFRIGERATOR

2. Filter

Replace the filter when the indicator light comes on or the performance of the icemaker or water dispenser decreases noticeably.

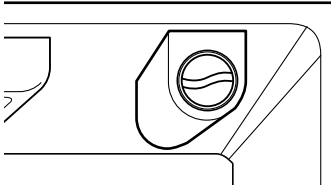

After changing the water filter cartridge, reset the water filter status display and indicator light by pressing and holding the **BUTTON** for 3 seconds. (page 18)

1. Remove the old cartridge.

Twist the knob of the cartridge counter clockwise.

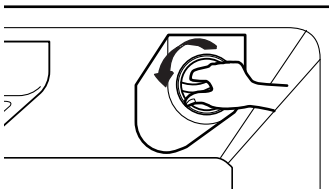

When the cartridge is removed, you will feel it click .

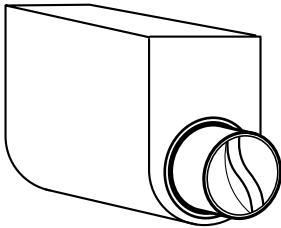

Pull out the cartridge.

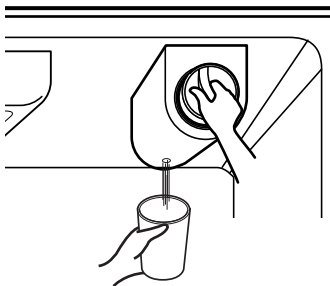

NOTE: There will be some water (25cc) in the filter cartridge. Some spilling may occur. Catch it in a bowl or towel.

2. Replace with a new cartridge.

Take the new cartridge out of its packaging and remove the protective cover from the o-rings.

With cartridge knob in the vertical position, push the new filter cartridge into the cover until it stops.

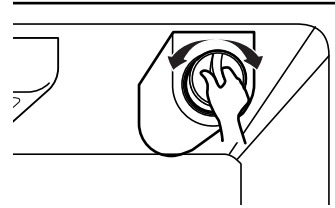

If you can't turn the filter from side to side, it isn't fully inserted. Push it in firmly and twist it into place. You will feel and hear the snap when it clicks into place.

Using the handle, twist the cartridge clockwise about 1/4 turn.

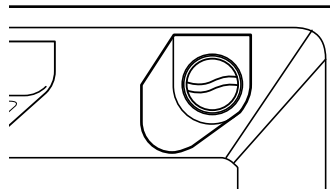
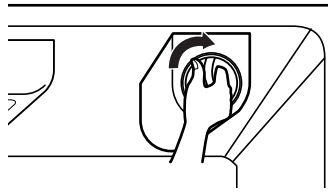

3. Flush the Water System After Replacing Filter Dispense water through the water dispenser for 3 minutes to purge the system.

There may be a little air in the line, causing noise or hissing. Run the water at the dispenser until the hissing stops to purge the air from the system.

NOTE: - To purchase replacement water filter cartridges, visit your local appliance dealer or part distributor.

- You can also visit our website : www.lgeus.com or call 1-800 -243-000.

FITER ASSEMBLY, WATER

LG MDL	PART NO	MAKER
GR-L267BV(T)R	5231JA2006A	CUNO
GR-L267BV(T)RA		
GR-L267BS(T,S)PA	5231JA2002A	CUNO
GR-L267BNRY		

HOW TO INSTALL THE REFRIGERATOR

■ Install Water Filter (Applicable to some models only)

■ Before Installing Water Filter

1. Before installing the filter, take out the top shelf of the refrigerator after tilting it to the direction ① and lifting it to the direction ② and move it to the lower part.
2. Remove the lamp cover by pressing the protrusion under the cover and pulling the cover to the front.

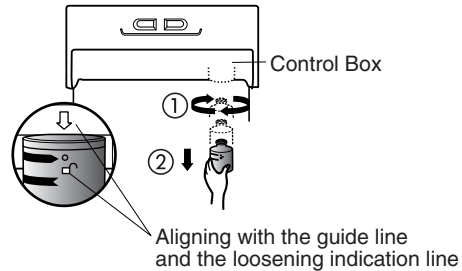
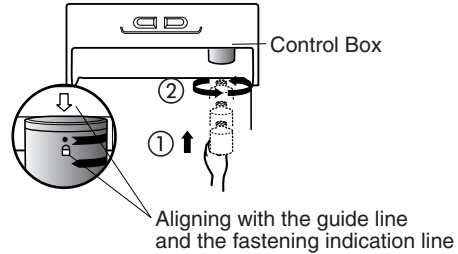
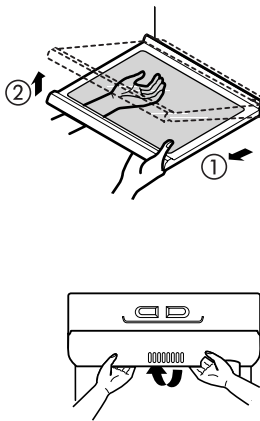

■ Installing water filter

1. Initial installation of water filter

Remove the filter substitute cap by turning it counterclockwise ① by 90 degrees and pulling it down.

Note : Keep the cap safe to use it later when you do not use the filter.

Remove the red cap from the filter and attach the sticker. Insert the upper part of the filter ① after aligning with the guideline marked on the control box, and fasten it by turning it clockwise by 90 degrees.

Note : Check that the guideline and the fastening indication line are aligned.

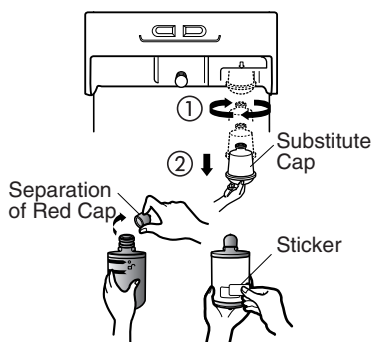

■ After installing water filter

Reassemble the lamp cover and the top shelf of the refrigerator. To place the top shelf of the refrigerator, raise the front part of the shelf a bit so that the hook of the shelf is fits into the groove.

To purge the water filter system, let the water run for at least 3 minutes.

NOTE : Open the refrigerator and check for water droplets on the shelf under the filter.

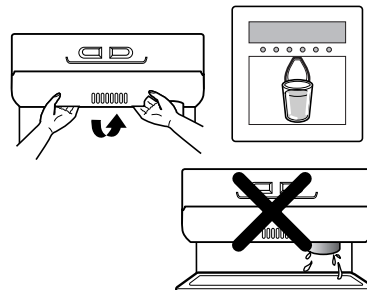

2. Replacement of water filter

While holding the lower part of the filter, turn it counterclockwise ① by 90 degrees and pull it down.

Note : Check that the guideline and the loosening indication line are aligned.

HOW TO INSTALL THE REFRIGERATOR

3. How to Control the Amount of Water Supplied to Icemaker.

3-1. Confirm the amount of water supplied to the icemaker.

1. Pull out the ice bin shelf in the upper part of the freezer compartment.

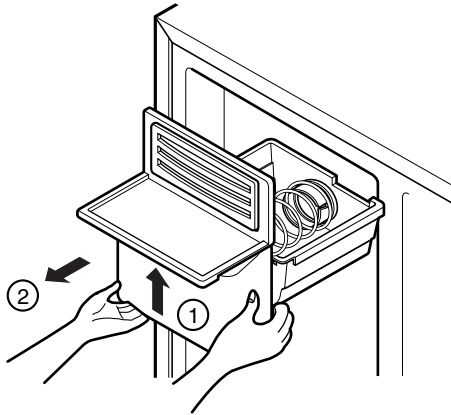

Caution : • Do not put hands or tools into the chute to confirm the operation of geared motor.
It may damage the refrigerator or hurt your hands.

2. Turn on the electricity after connecting water pipe.

- 1) Press the test switch under the icemaker for two seconds as shown below.
- 2) The bell rings(ding~dong), the ice tray rotates, and water comes out the icemaker water tube.
- 3) The water is supplied into the tray two or three times. The amount is small each time.
Put a container under the ice tray and press test switch.
- 4) When the ice tray rotates, the water in it will spill. Collect the spilled water and discard it.
- 5) When ice tray has finished rotation, water comes out the water tube. Check the amount that goes into the ice tray. (Refer to the drawing below. The optimum amount is 110cc.(almost 4 oz.))

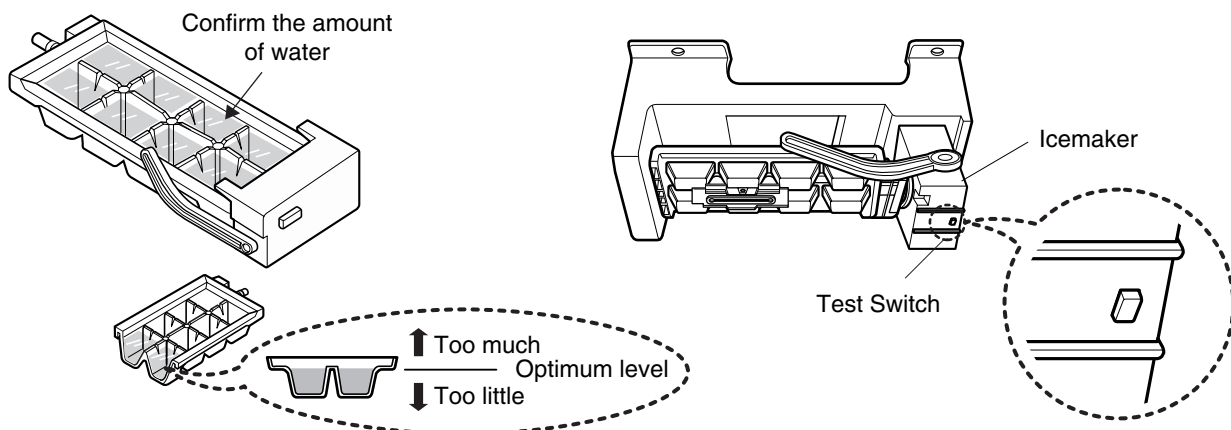

* It is acceptable if the adjusted water level is less than the optimum level.

HOW TO INSTALL THE REFRIGERATOR

3-2. Control the amount of water supplied to the icemaker.

Caution : • Unplug the power cord from the wall outlet and wait at least three minutes before removing the main PWB cover. 310 Volts are present in the control panel.

1. Disconnect PWB cover from the upper part of the refrigerator.
2. Adjust the amount of water supplied by using the DIP switches.

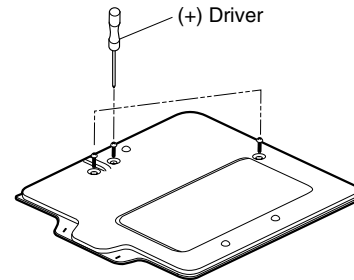

■ Water Supplying Time Control Option

No	GR-L267BV(T)R GR-L267BNRY (Refer to an appendix)			GR-L267BV(T)RA GR-L267BV(T,S)PA (Refer to an appendix)			REMARKS
	DIP SWITCH SETTING		WATER SUPPLY TIME	DIP SWITCH SETTING			
	S1	S2		S1	S2	S3	
1	OFF	OFF	6.5 SEC	OFF	OFF	OFF	* The quantity of water supplied depends on DIP switch setting conditions and water pressure as it is a direct tap water connection type. (the water supplied is generally 80 cc to 120 cc) * DIP switch is on the main PWB.
2	ON	OFF	5.5 SEC	ON	OFF	OFF	
3	OFF	ON	7.5 SEC	OFF	ON	OFF	
4	ON	ON	8.5 SEC	ON	ON	OFF	
5				OFF	OFF	ON	
6				ON	OFF	ON	
7				OFF	ON	ON	
8				ON	ON	ON	

- 1) The water supplying time is set at five seconds when the refrigerator is delivered.
- 2) The amount of water supplied depends on the setting time and water pressure (city water pressure).
- 3) If the ice cubes are too small, increase the water supplying time. This happens when too little water is supplied into the ice tray.
- 4) If the ice cubes stick together, decrease the water supplying time. This happens when too much water is supplied into the ice tray.

Caution : When adjusting the amount of water supplied, adjust step by step. Otherwise the water may spill over.

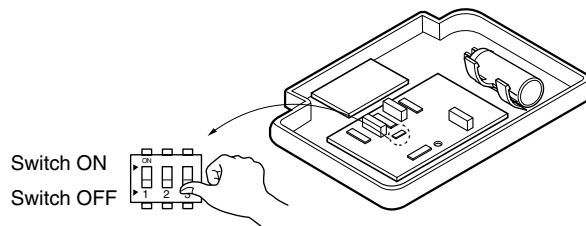

3. When the adjustment of the control switch for the amount of water supplied is complete, check the level of water in the ice

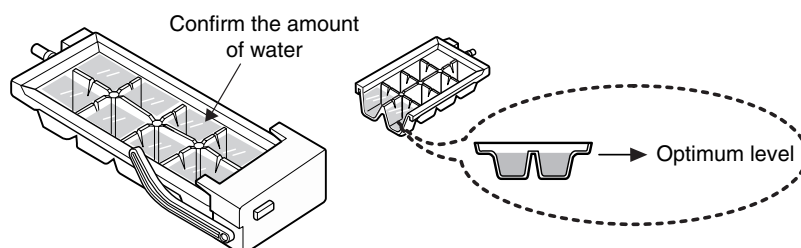

MICOM FUNCTION

1. Monitor Panel

1-1. GR-L267BV(T)RA, GR-L267BV(T, S)PA (Refer to appendix)

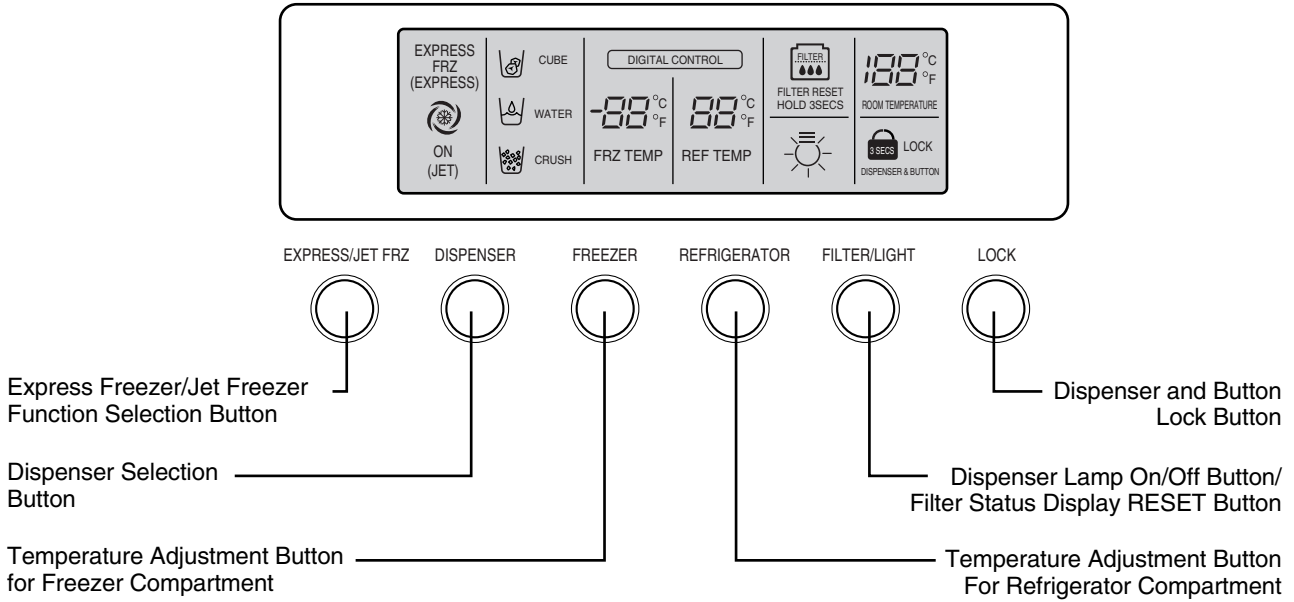

1-2. GR-L267BV(T)R (Refer to appendix)

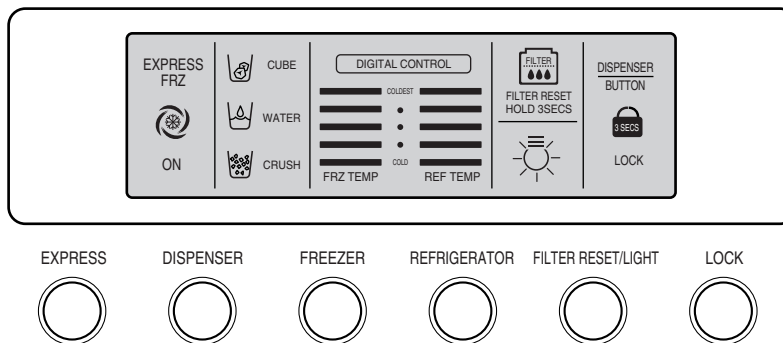

1-3. GR-L267BNRY (Refer to an appendix)

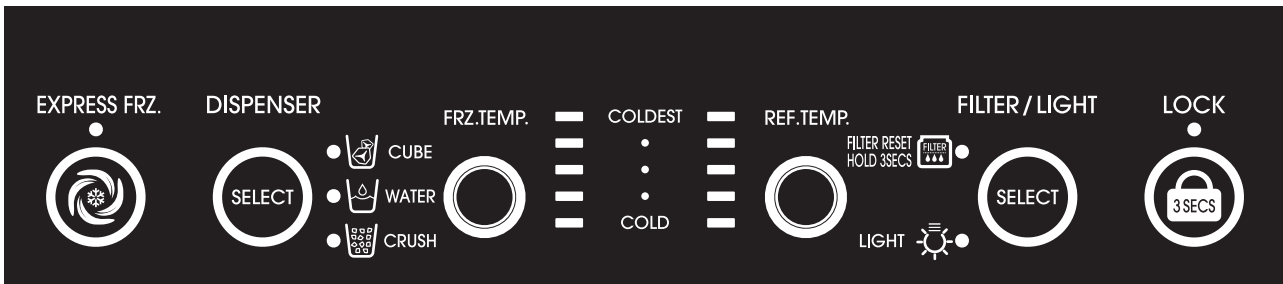

MICOM FUNCTION

1-4. Display Second Function

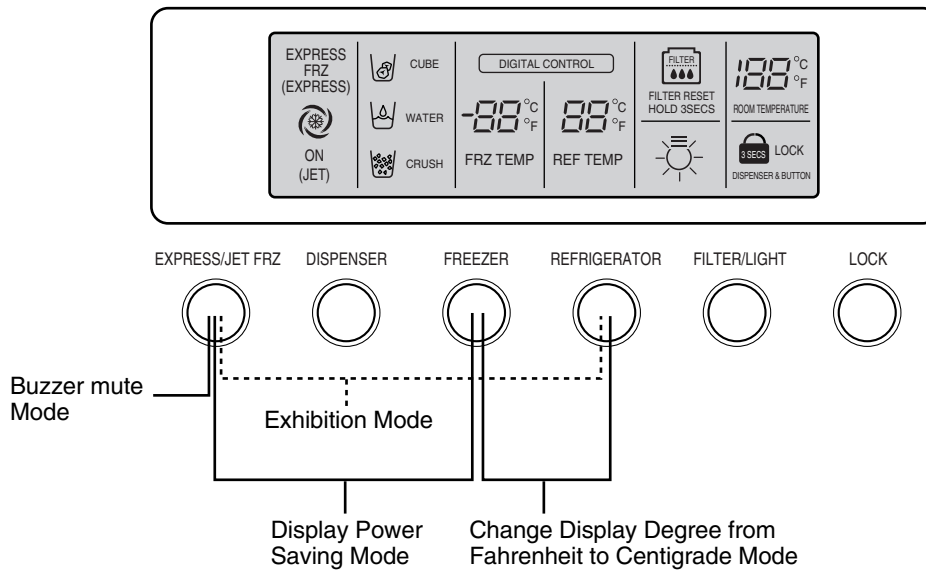

1. Buzzer sound mute Mode

The buzzer sound is set to OFF.

It activates by sounding the recognition sound of Ding~ after pressing and holding **Express FRZ** button more than 5 seconds. It inactivates when resetting the mode power.

2. Display Power saving Mode

Power Save Mode puts the display into standby mode until the door is opened.

To put the display into Power Save Mode, press and hold the **FREEZER** and **EXPRESS FRZ** buttons simultaneously for 5 seconds until the Ding~ sounds. (Use both buttons for this to work.) When Power Save Mode is activated, the display remains OFF unless a door is opened or a button is pressed. The display will return to the OFF position after 30 seconds' inactivity.

To remove the display from Power Save Mode, press and hold the **FREEZER** and **EXPRESS FRZ** buttons simultaneously for 5 seconds until the Ding~ sounds. The Power Save Mode default setting is OFF after a power interruption.

3. Change Display Degree to Centigrade Mode from Fahrenheit Mode

To change temperature display from Fahrenheit to Celsius press and hold **FREEZER** and **REFRIGERATOR** buttons simultaneously for more than 5 seconds. Do the same to convert back to Celsius.

4. Exhibition with Demo Mode

Demo mode is available for displaying the refrigerator in a sales setting or similar condition.

It allows the display, dispenser, lights, and fan to operate without running the compressor.

To enter the DEMO mode, press and hold the **REFRIGERATOR** and **EXPRESS FRZ** buttons simultaneously for 5 seconds until the Ding~ sounds.

















To exit the DEMO mode and return to normal operation, press and hold the **REFRIGERATOR** and **EXPRESS FRZ** buttons simultaneously for 5 seconds until the Ding~ sounds again.

The refrigerator will default to the NORMAL mode (DEMO mode OFF) if the power fails.

MICOM FUNCTION

2. Description of Function

2-1-1. Function of Temperature Selection

Division	Power Initially On	1st Press	2st Press	3th Press	4th Press
Setting temperature	5 4 3  2  1 	5 4  3  2  1 	5  4  3  2  1 	5 4 3 2  1 	5 4 3 2  1 
Temperature Control	Medium	Medium High	High	Low	Medium Low
Freezer Control	-2 °F	-5 °F	-8 °F	7 °F	1 °F
Refrigeration Control	37 °F	34 °F	32 °F	46 °F	41 °F

* The temperature can vary $\pm 3^{\circ}\text{C}$ (26.6 °F ~ 37.4 °F) depending on the load condition.

❖ Press the button to cycle through the settings in this order: (Medium) → (Medium High) → (High) → (Low) → (Medium Low).

- The temperature displayed is the SET temperature, NOT the actual temperature inside the refrigerator. The actual temperature varies, depending upon the temperature of items put into the refrigerator and other variables.
- It takes the refrigerator a while to get down to the set temperature from the initial power- on. Wait at least 24 hours after initial power- up to put food into the refrigerator. If the temperature is unsatisfactory, adjust it and wait 24 hours. It may take three or four days to get the adjustment to your satisfaction.
- The freezer is automatically set to MEDIUM HIGH if the icemaker is set to ON.

2-1-2. Outside temperature display function

1. The ambient temperature sensor is located under the upper right hinge cover. This sensor reads the temperature of the room and displays it in the upper right corner of the display.
2. The ambient temperature is displayed between 16 °F and 120 °F. Outside of that range, the display will show **Er**.
3. Since the ambient temperature sensor is located at the hinge, its reading may differ from other thermometers in the room.

MICOM FUNCTION

2-1-3. Lock Function (dispenser and display button lock)

1. In power application of refrigerator, the **LOCK** text is turned off at the right side of lock graphic of display with the lock release status.
2. If desiring to lock the display the dispenser and control panel, push on the LOCK button more than 3 seconds. LOCK text is turned on at the right side of lock graphic of display with lock status.
3. The buzzer sound and control panel and dispenser function is not performed even if pressing display button other than lock key in the lock status.
4. If desiring to release the lock status and pressing the lock button more than 3 seconds. LOCK text is turned off at the right side of lock graphic of display with the lock release status.

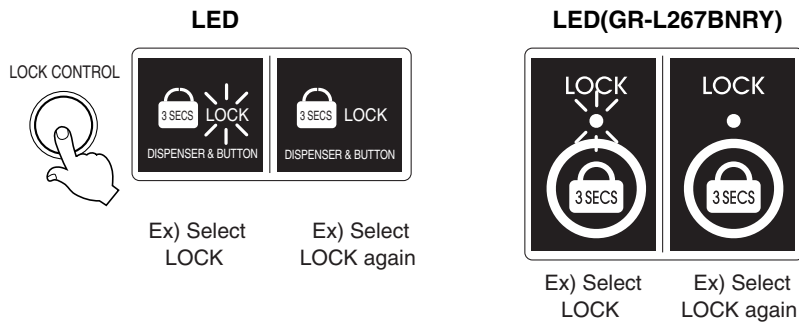

2-1-4. Filter condition display function

1. There is a replacement indicator light for the water filter cartridge on the dispenser.
2. Water filter needs replacement once six months.
3. Water filter light and FILTER RESET HOLD 3 SECONDS text turn on to tell you need to replace the filter soon.
4. After replace the filter, press and hold the lock button more than 3seconds. Then water filter light and FILTER RESET HOLD 3 SECONDS text turn off with reset status.

Classification	In initial Power On / Filter RESET	Replace indicator light on
Filter Status Display		

LED(GR-L267BNRY)

Classification	In initial Power On / Filter RESET	Replace indicator light on
Filter Status Display		

MICOM FUNCTION

2-2. Dispenser use selection

You can select water or ice.

- * Please select water, crunched ice, and cubed ice by pressing the  button as you desire.
- * Use your cup to press lightly on the actuator.
 - Each graphic is indicated for the selected function.
 - You'll hear a CLICK when the ice door closes 5 seconds after ice is dispensed.

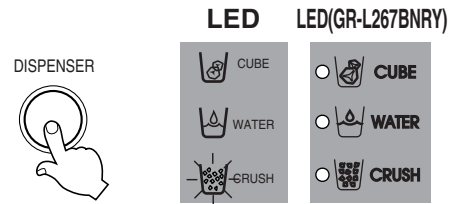

REFERENCE : Hold your cup in the dispenser for a few seconds after dispensing ice or water to catch the last few drops or pieces of ice.

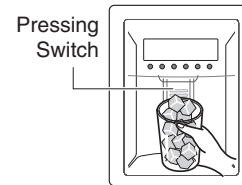

2-3. Express Freezing/JET Freezing Selection

Select this function to expedite freezing.

- Press the button to cycle to toggle between the settings.
- The arrow mark graphic remains at the **ON** status after flickering 4 times when selecting Special Refrigeration EXPRESS FRZ or JET FRZ.
- Expressing freezer or jet freezer function automatically turns off if a fixed time passes.

LED (GR-L267BV(T,S)PA) (Refer to an appendix)



LED (GR-L267BV(T)R, GR-L267BV(T)RA) (Refer to an appendix)



LED (GR-L267BNRY) (Refer to an appendix)



2-4. Dispenser Light

- Dispenser switch or dispenser light button turns the dispenser light **ON** and **OFF**.
- The dispenser light function is repeated following below whenever pressing FILTER RESET/LIGHT button.
- If dispenser light continuously turns on more than 7 minutes with dispenser light button, the dispenser light turns off automatically period.



Dispenser light
ON/OFF LED

MICOM FUNCTION

2-5. Express freezing

1. Express freezing increases the cooling speed in the freezer by running the fan and the compressor simultaneously.
2. Express freezing is released if the power fails and is restored.
3. The temperature setting is not changed when Express Freeze is selected.
4. You can change the temperature in the freezer and the refrigerator even if Express Freeze has been selected and is in progress.
5. The refrigerator operates independently of the Express Freeze setting and operation.
6. At the end of the Express Freeze cycle, the freezer defaults to its original setting.
7. If frost removal starting time is arrived during Express freezing, Express freezing operation is done only for the remaining time after completion of frost removal when the Express freezing operation time passes 90 minutes. If passing 90 minutes, Express freezing operation is done only for 2 hours after completion of frost removal.
8. If pressing Express freezing button during frost removal, the Express freezing LCD or LED is turned on but if pressing the Express freezing, compressor operates after the remaining time has passed.
9. If selection Express freezing within 7 minutes (delay for 7 minutes of compressor) after the compressor stops, compressor operates after the remaining time has passed.
10. The Freezer fan motor operates at the high speed of RPM during operation of Express freezing.

2-6. Jet Freezing (GR-L267BV(T,S)PA (Refer to appendix)

1. Jet Freeze increases the cooling speed in the Jet Freeze area of the freezer by running both the compressor and the Jet Freeze Box fan.
2. Jet freezing is released if the power fails and is restored.
3. The set temperature display is not changed by selecting Jet Freeze.
4. If Jet Freeze is selected, the compressor and the freezer fan will both operate.
The refrigerator temperature will drop and the Jet Freeze box motor will run for a maximum of 2 hours
After that, Jet Freeze is released and the freezer defaults to its original setting.
5. To keep the Jet Freeze fan motor from becoming ice- bound, the controller spins it up for 10 seconds every hour.
6. The Jet Freeze fan motor will not be detected as a failure because it is a 12 V DC motor.
7. The Jet Freeze fan motor will run for one minute if the freezer adjust button is pressed and held for over 1 second.

MICOM FUNCTION

2-7. OptiChill Function (GR-L267BV(T,S)PA Model) (Refer to appendix)

1. The OptiChill is positioned at the bottom of fresh food room separately and allow the user to select and adjust a desired temperature according to kinds of food such as meat, fish, vegetables and fruits and so on. The selected temperature to any kinds of food let user to keep their food longer.
2. OptiChill comprises of OptiChill sensor at the rear of OptiChill and a damper between OptiChill and freezer room and a temperature adjusting display at the top of it.
3. When OptiChill is turned on, it defaults to FRUIT VEGE. If only the refrigerator door is opened, the OptiChill LED will be ON.
4. Each consecutive press of the SELECT button cycles through the options in this order and shows a target temperature: FRUIT VEGE (39°F) → CHILED ROOM (30°F) → PARTIAL FREEZING (27°F) → FRUIT VEGE (39°F).
5. The OptiChill temperature is read by the MICOM. The MICOM will close and open the damper based upon the temperature.
6. To keep the OptiChill damper from becoming ice- bound, the controller opens and/ or closes it every hour.



NOTCH	Partial Freezing	Chilled Room	Fruit VEGE
Display	27°F	30°F	39°F

MICOM FUNCTION

2-8. Control of variable type of freezing fan

1. To increase cooling speed and load response speed, MICOM variably controls freezing room fan motor at the high speed of RPM and standard RPM.
2. MICOM only operates in the input of initial power or express freezing operation or load response operation for the high speed of RPM and operates in the standard RPM in other general operation.
3. If opening doors of freezing / cold storage room or home bar while fan motor in the freezing room operates, the freezing room fan motor normally operates (If being operated in the high speed of RPM, it converts operation to the standard RPM). However, if opening doors of freezing room or home bar, the freezing room fan motor stops.
4. As for monitoring of BLDC fan motor error in the freezing room, MICOM immediately stops the fan motor by determining that the BLDC fan motor is locked or fails if there would be position signal for more than 115 seconds at the BLDC motor. Then it displays failure (refer to failure diagnosis function table) at the display part of refrigerator, the BLDC motor doesn't operate more. If you want to operate the BLDC motor, turn off and on power resource.

2-9. Control of cooling fan motor

1. The cooling fan motor performs ON/OFF control by linking with the COMP.
2. It controls at the single RPM without varying RPM.
3. Failure sensing method is same as in fan motor of freezing fan motor (refer to failure diagnosis function table for failure display). (Except GR-L267BNRY)

2-10. Door opening alarm

1. Buzzer generates alarm sound if doors are not closed even when more than a minute consecutively has passed with doors of freezer / refrigerator or home bar opened.
2. After the door has been open for one minute, the buzzer sounds for 1/2 second and then sounds three times every 30 seconds.
3. If all doors are closed when the alarm sounds, it is cancelled immediately.

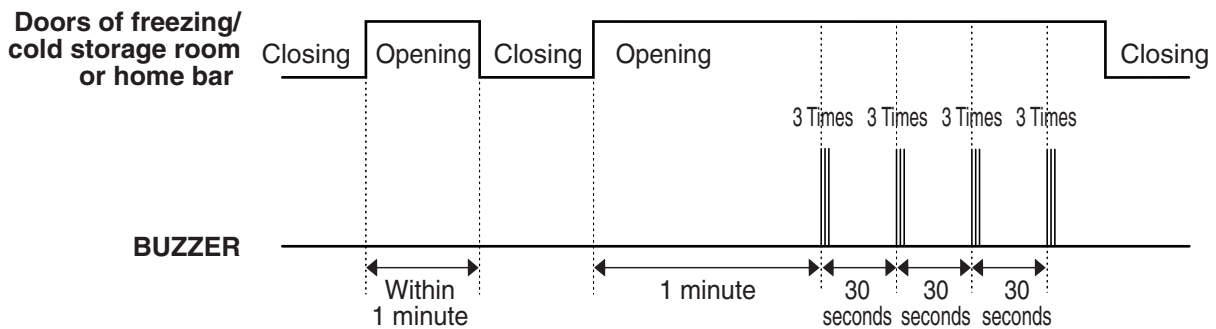

2-11. Ringing of button selection buzzer

1. The ding~ will sound whenever a button is pressed.

MICOM FUNCTION

2-12. Ringing of compulsory operation, compulsory frost removal buzzer

1. If pressing the test button in the Main PCB, a beep will sound.
2. In selecting compulsory operation, alarm sound is repeated and completed in the cycle of On for 2/10 second and Off for 1 8/10 second three times.
3. In selecting compulsory frost removal, alarm sound is repeated and completed in the cycle of On for 2/10 second , Off for 2/10 second, On for 2/10 second and Off for 1 4/10 second three times.

2-13. Defrost function

1. Defrost is performed whenever total operation time of compressor becomes 7 ~ 7 1/2 hour.
2. In providing initial power (or returning power failure), frost removal starts whenever total operation time of compressor becomes 4 ~ 4 1/2 hour.
3. Defrost is completed if temperature of a defrost sensor becomes more than 5°C after starting defrost. The defrost cycle will fail if there frigerator does not reach a temperature of 5°C (9 °F)two hours into the defrost cycle.
4. The defrost cycle will not operate of the defrost sensor fails, arcs, or shorts out.

2-14. Refrigerator lamp automatically off

- Refrigerator lamp turns on and off by refrigerator door switch.
- If refrigerator lamp continuously turns on more than 7 minutes, the refrigerator room lamp turns off automatically period.

MICOM FUNCTION

2-15. Sequential operation of built-in product

Built-in products such as compressor, frost removal heater, freezing room fan, Cooling fan and step motor damper are operated sequentially as follows to prevent noise and part damage due to simultaneous operation of several parts in applying initial power and completing test.

Function	Load Operation Sequence	Remark
In applying Initial power	<p>When temperature of a frost removal sensor becomes more than 45°C (113°F) (In purchase, movement)</p> <pre> graph LR A[POWER ON] -- 0.3 sec. --> B[COMP ON] B -- 0.3 sec. --> C[F-FAN & C-FAN ON] C -- 0.3 sec. --> D[R-STEP MOTOR DAMPER ON] D -- 0.3 sec. --> E[OPTICHILL STEP DAMPER MOTOR ON] </pre>	<p>If error occurs during operation, initial operation is not done.</p> <p>■ Sequence of load operation when closing Freezer and Refrigerator.</p>
	<p>When temperature of a frost removal sensor becomes less than 45°C (113°F) (In power failure, service)</p> <pre> graph LR A[POWER ON] -- 0.3 sec. --> B[FROST REMOVAL HEATER ON] B -- 0.3 sec. --> C[FROST REMOVAL HEATER OFF] C -- 6.0 sec. --> D[DAMPER & DUCT DOOR & OPTICHILL HEATER ON] D -- 0.3 sec. --> E[DAMPER & DUCT DOOR & OPTICHILL HEATER OFF] F[PIPE & DISP' HEATER ON] -- 0.3 sec. --> G[PIPE & DISP' HEATER OFF] G -- 0.3 sec. --> H[COMP ON] H -- 0.3 sec. --> I[F-FAN & C-FAN ON] I -- 0.3 sec. --> J[R-STEP MOTOR DAMPER ON] J -- 0.3 sec. --> K[OPTICHILL STEP DAMPER MOTOR ON] </pre>	
TEST MODE	<p>Test mode 1 (Compulsory function)</p> <pre> graph LR A[TEST SWITCH PRESS Once] --> B[OTHER LOAD OFF] B -- 0.3 sec. --> C[COMP ON] C -- 0.3 sec. --> D[F-FAN & C-FAN ON] D -- 0.3 sec. --> E[R-STEP MOTOR DAMPER ON] E -- 0.3 sec. --> F[OPTICHILL STEP DAMPER MOTOR CLOSE] </pre>	<p>If pressing switch once more in the test mode 2 or temperature of a frost removal sensor is more than 45°C (113°F), it immediately returns to the test mode for initial operation (COMP operates after 7 minutes).</p>
	<p>Test mode 2 (Compulsory frost removal)</p> <pre> graph LR A[TEST SWITCH PRESS 2 Times] --> B[COMP OFF] B -- 0.3 sec. --> C[F-FAN & C-FAN OFF] C -- 0.3 sec. --> D[FROST REMOVAL HEATER ON] D -- 0.3 sec. --> E[R-STEP MOTOR DAMPER CLOSE] </pre>	

MICOM FUNCTION

2-16. Failure Diagnosis Function

1. Failure diagnosis function is to facilitate service when a failure occurs and produces an error code.
2. In occurrence of failure, pressing the function adjustment button does not perform function.
3. If nonconforming matters occurred are released during display of failure code, MICOM returns to the original state (Reset).
4. Failure code is displayed on the display part of setting temperature for the freezing room and the display part of setting temperature for the cold storage room of display, which are placed at the display part of a refrigerator. All the display graphics other than a failure code are turned off.

(1) GR-L267BV(T)R Model (Refer to appendix)

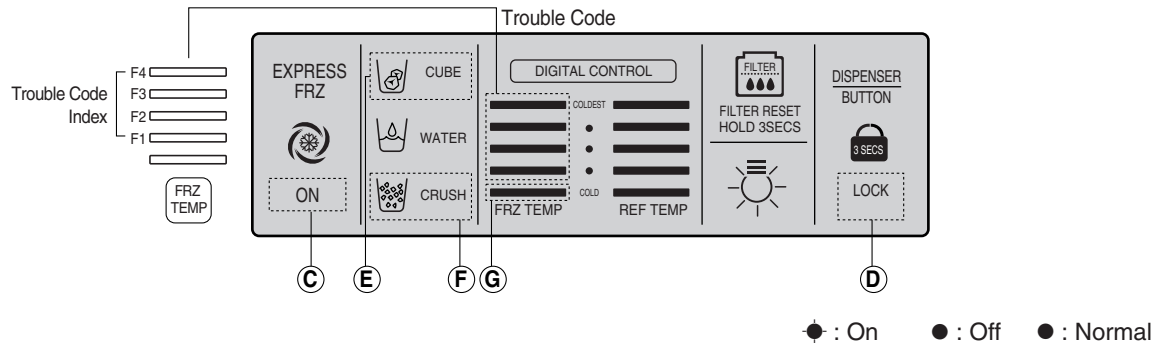

No.	Item	Trouble Code Index				Contents of failure	Product operation status in failure				
		F1	F2	F3	F4		Compressor	Freezing BLDC motor	Cooling BLDC motor	Defrost Heater	Stepping motor damper
1	Abnormal freezer sensor	○	●	●	●	Freezer sensor short circuit	ON for 15minutes/ OFF for 15minutes	Standard RPM	○	○	○
2	Abnormal refrigerator sensor 1 (R1) (Upper part in the refrigerator compartment)	●	○	●	●	Refrigerator sensor1 short circuit	○	Standard RPM	○	○	Full opening for 10 minutes/ Full closing for 15 minutes
3	Abnormal refrigerator sensor 2 (R2) (Upper part in the refrigerator compartment)	Normal display (Note 1)				Refrigerator sensor2 short circuit	○	Standard RPM	○	○	○
4	Abnormal defrost sensor	●	●	○	●	Abnormal short circuit	○	Standard RPM	○	No defrost	○
5	Failed defrosting	○	○	○	○	Defrost heater, temperature fuse short circuit, unplugged connector(indicated 4 hour later after trouble)	○	Standard RPM	○	○	○
6	Abnormal freezing BLDC motor	○	●	●	○	Motor defect, hooked of lead wire to fan, contact of structures with fan, short or open of lead wire(there is no signal of BLDC motor more than 115 seconds in operation of fan motor)	○	OFF	○	○	○
7	Abnormal cooling BLDC motor	○	○	●	●		○	Standard RPM	OFF	○	○
8	Abnormal ambient sensor	Normal display (Note 1)				Ambient sensor short circuit	○	○	○	○	○
9	Abnormal icemaker sensor	Normal display (Note 1)				Icemaker sensor short circuit	○	○	○	○	○
10	Abnormal icemaker unit	Normal display (Note 1)				Faulty icemaker unit motor or hall ic, lead wire short circuit, faulty motor driving circuit	○	○	○	○	○
11	Abnormal W/T sensor	Normal display (Note 1)				Water Tank sensor short circuit	○	○	○	○	○

MICOM FUNCTION

(2) GR-L267BV(T)RA, GR-L267BV(T,S)PA (Refer to appendix)

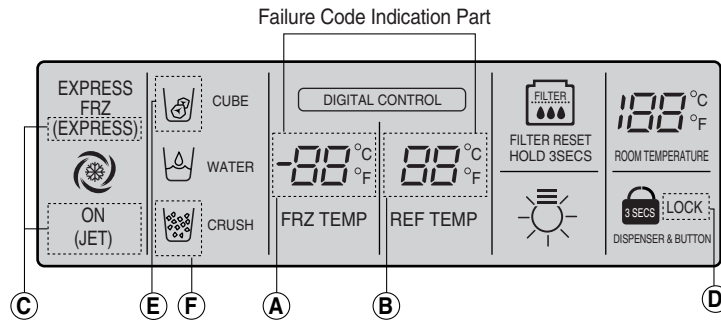

○ : Proper operation

No.	Item	Failure code indication part		Contents of failure	Product operation status in failure				
		Freezer room notch temperature display	Refrigerator room notch temperature display		Compressor	Freezing BLDC motor	Cooling BLDC motor	Defrost Heater	Stepping motor damper
1	Abnormal freezer sensor	Er	FS	Freezer sensor short circuit	ON for 15minutes/ OFF for 15minutes	Standard RPM	○	○	○
2	Abnormal refrigerator sensor 1 (R1) (Upper part in the refrigerator compartment)	Er	rS	Refrigerator sensor1 short circuit	○	Standard RPM	○	○	Full opening for 10 minutes/ Full closing for 15 minutes
3	Abnormal refrigerator sensor 2 (R2) (Middle part in the refrigerator compartment)	Normal display (Note 2)		Refrigerator sensor2 short circuit	○	Standard RPM	○	○	○
4	Abnormal defrost sensor	Er	dS	Abnormal short circuit	○	Standard RPM	○	No defrost	○
5	Failed defrosting	Er	dH	Defrost heater, temperature fuse short circuit, unplugged connector(indicated 4 hour later after trouble)	○	Standard RPM	○	○	○
6	Abnormal freezing BLDC motor	Er	FF	Motor defect, hooked of lead wire to fan, contact of structures with fan, short or open of lead wire(there is no signal of BLDC motor more than 115 seconds in operation of fan motor)	○	OFF	○	○	○
7	Abnormal cooling BLDC motor	Er	CF		○	Standard RPM	OFF	○	○
8	Abnormal communication	Er	CO	Short or open of lead wire connecting between main PCB and display PCB, transmission tr and receiving part	○	Standard RPM	○	○	○
9	Abnormal ambient sensor	Normal display (Note 2)		Ambient sensor short circuit	○	○	○	○	○
10	Abnormal Optichill sensor	Normal display (Note 1)		Optichill sensor short circuit	○	○	○	○	○
11	Abnormal icemaker sensor	Normal display (Note 1)		Icemaker sensor short circuit	○	○	○	○	○
12	Abnormal icemaker unit	Normal display (Note 1)		Faulty icemaker unit motor or hall ic, lead wire short circuit, faulty motor driving circuit.	○	○	○	○	○
13	Abnormal W/T sensor	Normal display (Note 1)		Water Tank Sensor short circuit	○	○	○	○	○
14	Abnormal Drive Micom Communication	Normal display (Note 1)		Abnormal of TR, Micom between Set Micom and Drive Micom (OptiChill Display)in MAIN PCB	○	○	○	○	○

MICOM FUNCTION

(3) GR-L267BNRY (Refer to appendix)

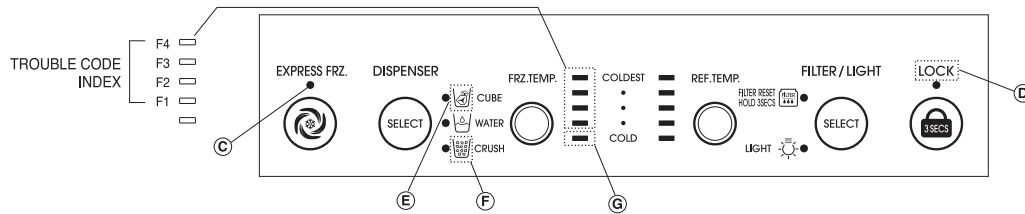

○ : PROPER OPERATION

NO	ITEM	TROUBLE CODE INDEX				CONTENTS OF FAILURE	PRODUCT OPERATION STATUS IN FAILURE				
		F1	F2	F3	F4		COMPRESSOR	FREEZING BLDC MOTOR	COOLING BLDC MOTOR	DEFROST HEATER	STEPPING MOTOR DAMPTER
1	ABNORMAL FREEZER SENSOR	○	●	●	●	FREEZER SENSOR SHORT CIRCUIT	ON FOR 15 MINUTES / OFF FOR 15 MINUTES	STANDARD RPM	○	○	○
2	ABNORMAL REFRIGERATOR SENSOR1(R1) (UPPER PART IN THE REFRIGERATOR COMPARTMENT)	●	○	●	●	REFRIGERATOR SENSOR1 SHORT CIRCUIT	○	STANDARD RPM	○	○	FULL OPENING FOR 10 MINUTES / FULL CLOSING FOR 15 MINUTES
3	ABNORMAL REFRIGERATOR SENSOR2(R2) (UPPER PART IN THE REFRIGERATOR COMPARTMENT)	NORMAL DISPLAY (NOTE 1)				REFRIGERATOR SENSOR2 SHORT CIRCUIT	○	STANDARD RPM	○	○	○
4	ABNORMAL DEFROST SENSOR	●	●	○	●	ABNORMAL SHORT CIRCUIT	○	STANDARD RPM	○	NO DEFROST	○
5	FAILED DEFROSTING	○	○	○	○	DEFROST HEATER, TEMPERATURE FUSE SHORT CIRCUIT, UNPLUGGED CONNECTOR (INDICATED 4 HOURS LATER AFTER TROUBLE)	○	STANDARD RPM	○	○	○
6	ABNORMAL FREEZING BLDC MOTOR	○	●	●	○	MOTOR DEFECT, HOOKED OF LEAD WIRE TO FAN, CONTACT OF STRUCTURES WITH FAN, SHORT OR OPEN OF LEAD WIRE (THERE IS NO SIGNAL OF BLDC MOTOR MORE THAN 65 SECONDS IN OPERATION OF FAN MOTOR)	○	OFF	○	○	○
7	ABNORMAL AMBIENT SENSOR	NORMAL DISPLAY (NOTE 1)				AMBIENT SENSOR SHORT CIRCUIT	○	○	○	○	○
8	ABNORMAL ICEMAKER SENSOR	NORMAL DISPLAY (NOTE 1)				ICEMAKER SENSOR SHORT CIRCUIT	○	○	○	○	○
9	ABNORMAL ICEMAKER UNIT	NORMAL DISPLAY (NOTE 1)				FAULTY ICEMAKER UNIT MOTOR OR HALL IC, LEAD WIRE SHORT CIRCUIT, FAULTY MOTOR DRIVING CIRCUIT	○	○	○	○	○
10	ABNORMAL W/T SENSOR	NORMAL DISPLAY (NOTE 1)				WATER TANK SENSOR SHORT CIRCUIT	○	○	○	○	○

MICOM FUNCTION

Note1) R2-sensor, OptiChill sensor and water tank sensor, Ice maker-sensor, Ice maker Unit are not indicated on the failure indicating part but indicated in checking Display (When pressing for more than the button of freezing temperature and super freezer button for more than 1 second).

R2-sensor (middle room) or Abnormal Drive Micom Communication	<input type="checkbox"/> Normal: LED or LCD graphic on the (C) part turns on <input type="checkbox"/> Abnormal: LED or LCD graphic on the (C) part turns off	The other LED or LCD Graphics Turn On.
OptChill sensor or Water tank sensor	<input type="checkbox"/> Normal: LED or LCD graphic on the (D) part turns on <input type="checkbox"/> Abnormal: LED or LCD graphic on the (D) part turns off	
Icemaking sensor	<input type="checkbox"/> Normal: LED or LCD graphic on the (E) part turns on <input type="checkbox"/> Abnormal: LED or LCD graphic on the (E) part turns off	
Icemaker unit	<input type="checkbox"/> Normal: LED or LCD graphic on the (F) part turns on <input type="checkbox"/> Abnormal: LED or LCD graphic on the (F) part turns off	
Ambient sensor (GR-L267V(T)R (Refer to appendix) Model Only)	<input type="checkbox"/> Normal: LED or LCD graphic on the (G) part turns on <input type="checkbox"/> Abnormal: LED or LCD graphic on the (G) part turns off	

Note 2) Freezer notch temperature display and refrigerator notch temperature display (Failure code indication part) are normally indicated in abnormal ambient sensor, and **Er** indicated on the ambient temperature display (except for the ambient temperature display, other LEDs or LCDs are indicated normally)

* LCD (LED) check function: If simultaneously pressing express freezer button and freezing temperature adjustment button for a second, the back light is turned on and all display LCD(LED) graphics on. If releasing the button, the LCD (LED) graphic displays the previous status, the back light is turned off (LCD graphic and back light ON/OFF check).

MICOM FUNCTION

2-17. Test Function

1. The purpose of test function is to check function of the PWB and product and to search for the failure part at the failure status.
2. Test button is placed on the main PCB of refrigerator (test switch), and the test mode will be finished after maximum 2 hours regardless of test mode and then is reset to the normal status.
3. Function adjustment button is not perceived during performance of test mode.
4. In finishing test mode, always pull the power cord out and then plug-in it again for the normal state.
Always wait at least 3 minutes before restarting a compressor to allow the pressures to equalize and to avoid damage.
5. If nonconforming contents such as sensor failure are found during performance of test mode, release the test mode and display the failure code.
6. If you press the TEST button while a failure code is displayed, the test mode will not begin.

Mode	Operation	Contents	Remarks
Test 1	Press test button once (strong cold mode)	<ol style="list-style-type: none"> 1. Continuous operation of compressor 2. Continuous operation of freezing bldc motor (high-speed RPM) and cooling bldc motor 3. Defrost heater turns off 4. Stepping motor damper is completely opened (open of baffle) 5. Optichil stepping motor damper is completely closed. 6. All display LEDs or LCD graphics turn on. 	Freezing fan turns off in door opening.
Test 2	Press test button once at the test mode 1 status (forced defrost mode)	<ol style="list-style-type: none"> 1. Compressor OFF 2. Freezing bldc motor and cooling bldc motor turn off 3. Defrost heater turns on 4. Stepping motor damper is completely closed (closing of baffle) 5. OptiChil stepping motor damper is completely closed. 6. GR-L267BV(T)RA, GR-L267BV(T,S)PA (Refer to appendix) GR-L267BV(T)R (Refer to appendix) 	Return to the normal mode when the defrost sensor is above +5°C
Normal Status	Press test button once at the test mode 2 status	Return to the initial status.	Compressor will operate after delay for 7 minutes

TEST MODE1 STATUS DISPLAY

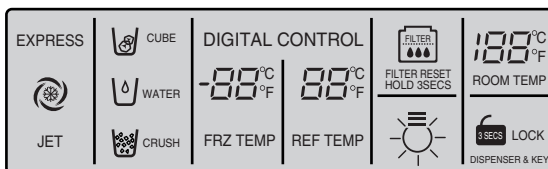

TEST MODE2 STATUS DISPLAY

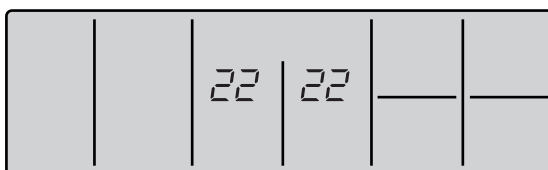

MICOM FUNCTION

2-18. Function of dispenser and water dispenser built-in

1. The dispenser allows ice and water to be served without opening the freezer door.
2. Press the dispenser switch (the rubber button) after selecting crushed ice, cubed ice, or water. The dispenser door will open automatically. It will close automatically 5 seconds after dispensing is completed, and you will hear the CLICK.
3. The dispenser will not operate when the freezer door is open.
4. The ice dispenser will automatically stop after 3 minutes even without an OFF signal. The ice door will close automatically 5 seconds after that, and you will hear the CLICK.
5. Dispenser Lamp ON/ OFF Function.
The dispenser lamp is operated in conjunction with the dispenser switch. It comes on when ice or water is dispensed, and turns off when dispensing is completed.
6. Selection function of water/crushed/cube ice
 - 1) This allows the selection of water/cubed/crushed ice. Press the button to cycle through WATER → CRUSHED →CUBED.
 - 2) At initial power-on, the dispenser defaults to CUBED ICE.
 - 3) When CUBE ICE is selected, the geared motor rotates so CUBED ICE is dispensed.
 - 4) When CRUSHED ICE is selected, the geared motor rotates in the opposite direction so CRUSHED ICE is dispensed.
7. Water dispenser function
 - 1) Select WATER to dispense water.
 - 2) The water line is a direct connection to the household water supply. If water is selected at the dispenser, a solenoid opens and allows water to flow. A similar solenoid is operated in conjunction with the icemaker to fill it at the appropriate time in its cycle.

EXPLANATION FOR MICOM CIRCUIT

1. Explanation for PWB circuit

1-1. Power circuit

The power circuit includes a Switched Mode Power Supply (SMPS). It consists of a rectifier (BD1 and CE1) converting AC to DC, a switch (IC2) switching the DC voltage, a transformer, and a feedback circuit (IC3 and IC4).

Caution : Since high voltage (160 Vdc) is maintained at the power terminal, wait at least 3 minutes after unplugging the appliance to check the voltages to allow the current to dissipate.

Voltage of every part is as follows:

Part	VA1	CE1	CE2	CE3	CE4	CE5
Voltage	120 Vac	160 Vdc	14 Vdc	12 Vdc	15.5 Vdc	5 Vdc

(1) GR-L267BV(T)R (Refer to appendix)

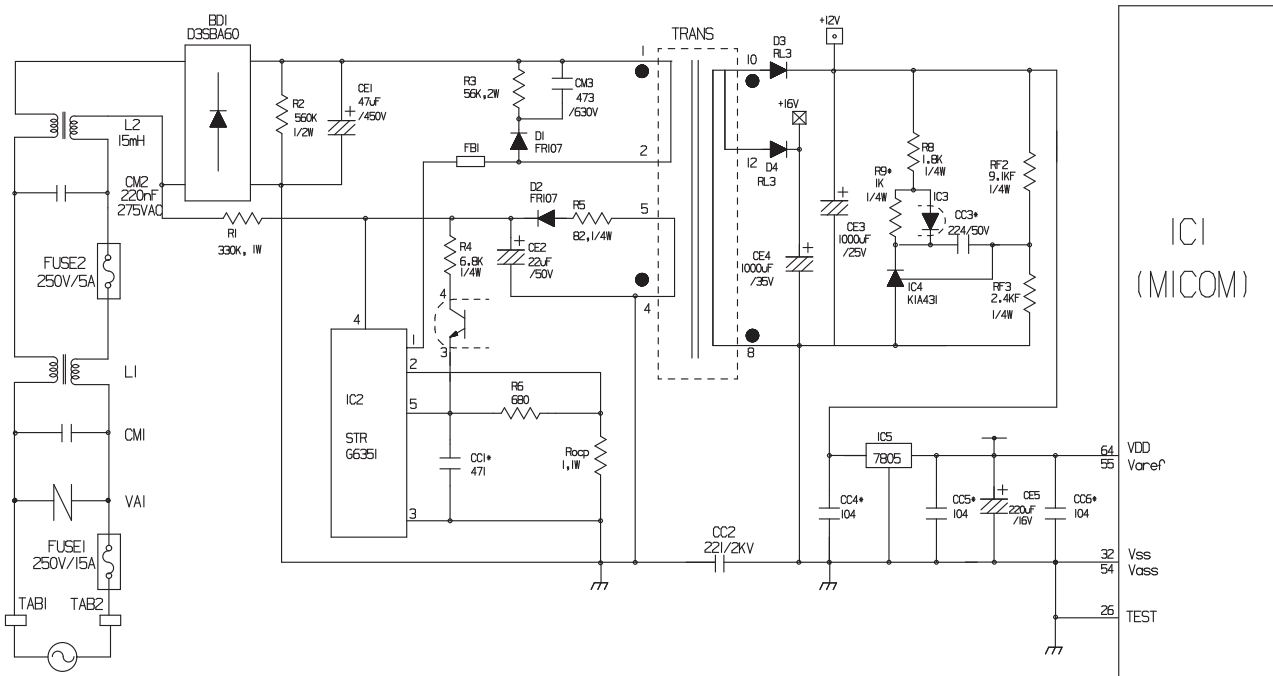

EXPLANATION FOR MICOM CIRCUIT

1-2. Oscillation circuit

The oscillation circuit generates a basic clock signal for synchronization and time calculation related to the transmission of data and calculations made by the MICOM (IC1). The oscillator (OSC1) must always be replaced with an exact rated part, because if this spec is changes, the time calculations of the MICOM will be affected and it might not work at all.

(1) GR-L267BV(T)R, BNRV (Refer to appendix)

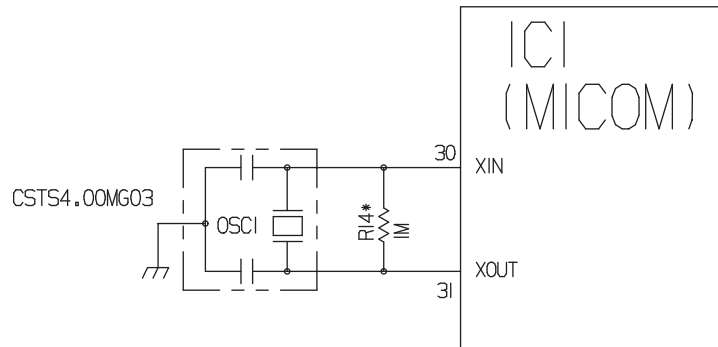

(2) GR-L267BV(T)RA (Refer to appendix)

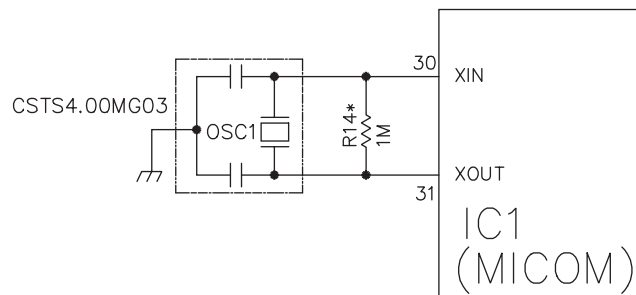

(3) GR-L267BV(T,S)PA (Refer to appendix)

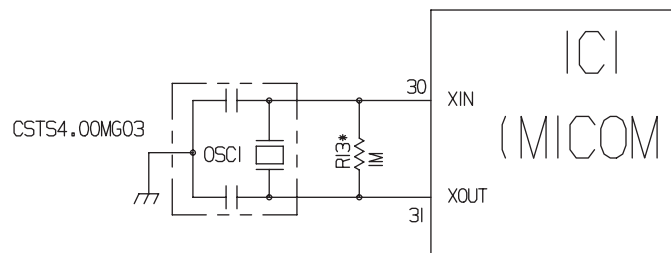

EXPLANATION FOR MICOM CIRCUIT

1-3. Reset circuit

The RESET circuit allows various parts of the MICOM, such as RAM, defrosting, etc., to be restarted from the initial state when power is interrupted or restored. A LOW signal applied to the reset terminal for 10 ms causes the MICOM to reset itself. During normal operation, the voltage at the reset terminal is 5 Vdc. If the reset fails, the MICOM will not operate.

(1) GR-L267BV(T)R, BNRV (Refer to appendix)

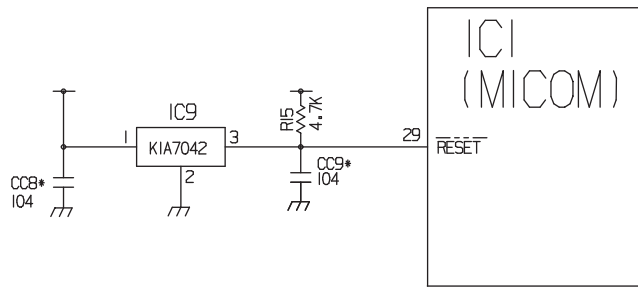

(2) GR-L267BV(T)RA (Refer to appendix)

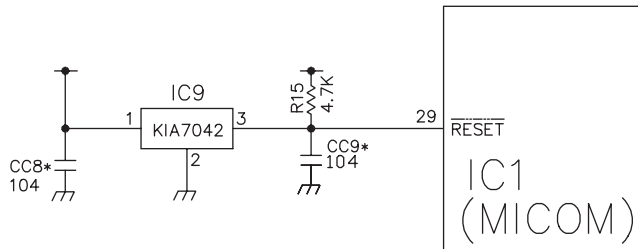

(3) GR-L267BV(T,S)PA (Refer to appendix)

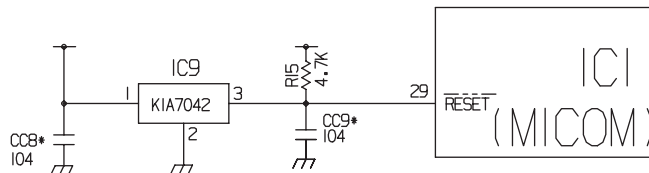

EXPLANATION FOR MICOM CIRCUIT

1-4. Load/dispenser operation, door opening circuit

1. LOAD DRIVING CIRCUIT

- * The fan operates at the regular speed even if the door of the refrigerator or freezer is opened. When the doors are closed, the fan reverts to its original speed.
- * (A), (B), (C), and (D) of door switch for the freezer or refrigerator are connected to the door open sensing circuit in parallel toward both ends of switch to determine door open at MICOM.
- * In the TEST mode, the fan will stop if any door is opened. It will resume operation when the door is closed.

Type of Load	Compressor	Frost Removal Heater	AC Converting Relay	Refrigerator LAMP	Dispenser Heater
Measuring part (IC6)	IC6-16	IC6-13	IC6-12	IC6-15	IC6-14
Status	ON	Within 1 V			
	OFF	12 V			

(1) GR-L267BV(T)R (Refer to appendix)

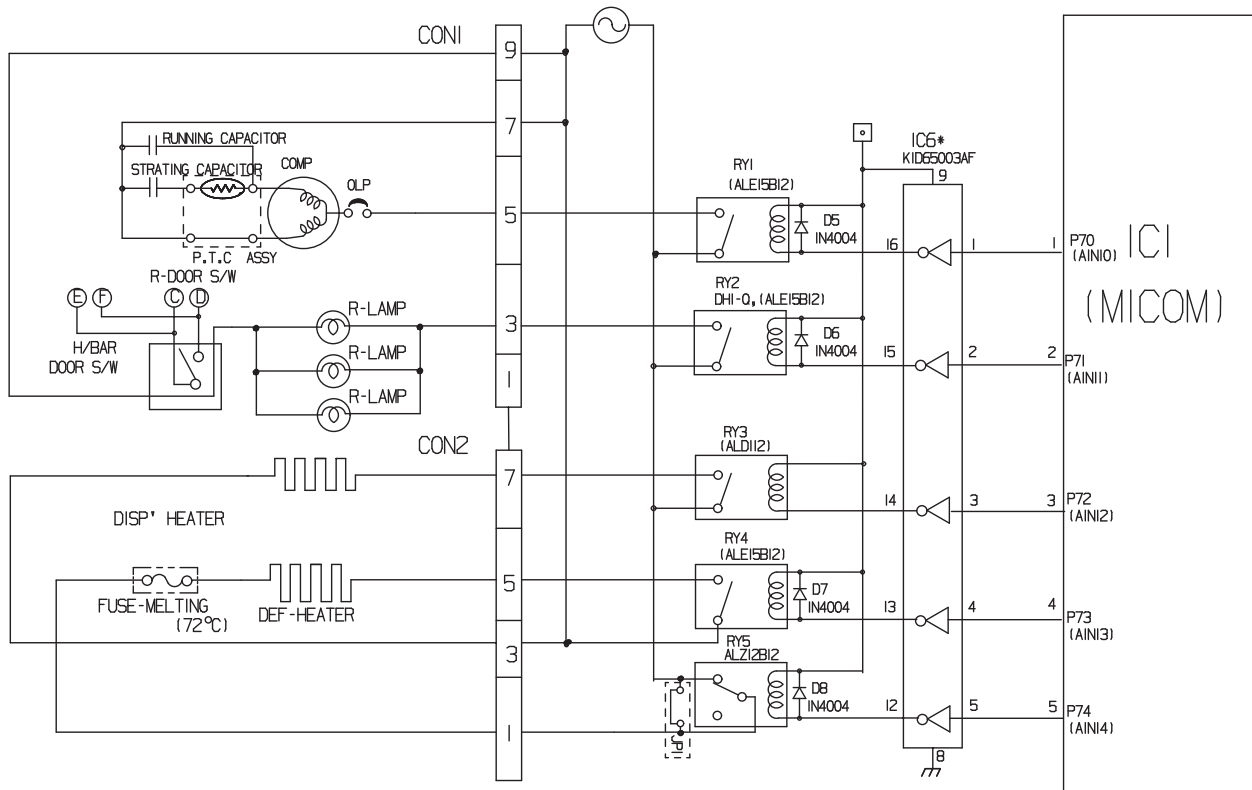

EXPLANATION FOR MICOM CIRCUIT

(2) GR-L267BNRY (Refer to appendix)

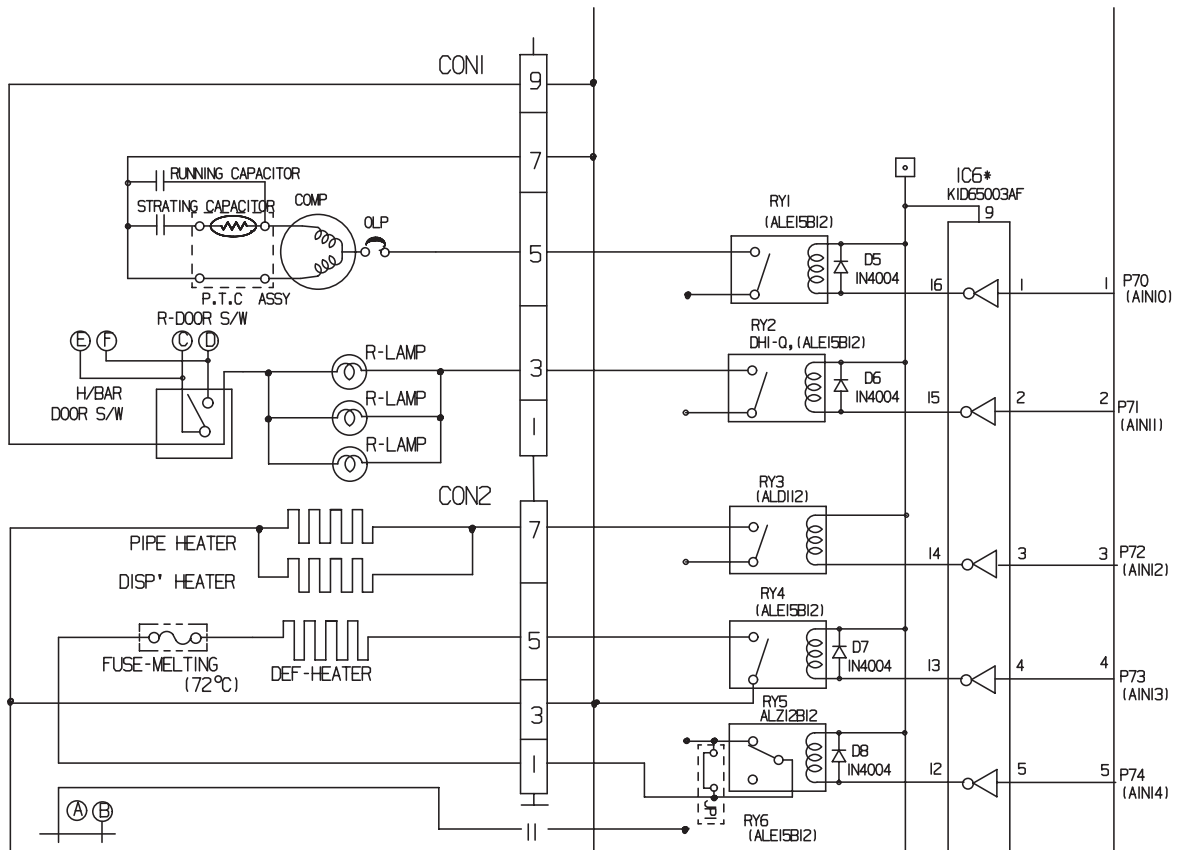

EXPLANATION FOR MICOM CIRCUIT

(3) GR-L267BV(T)RA (Refer to appendix)

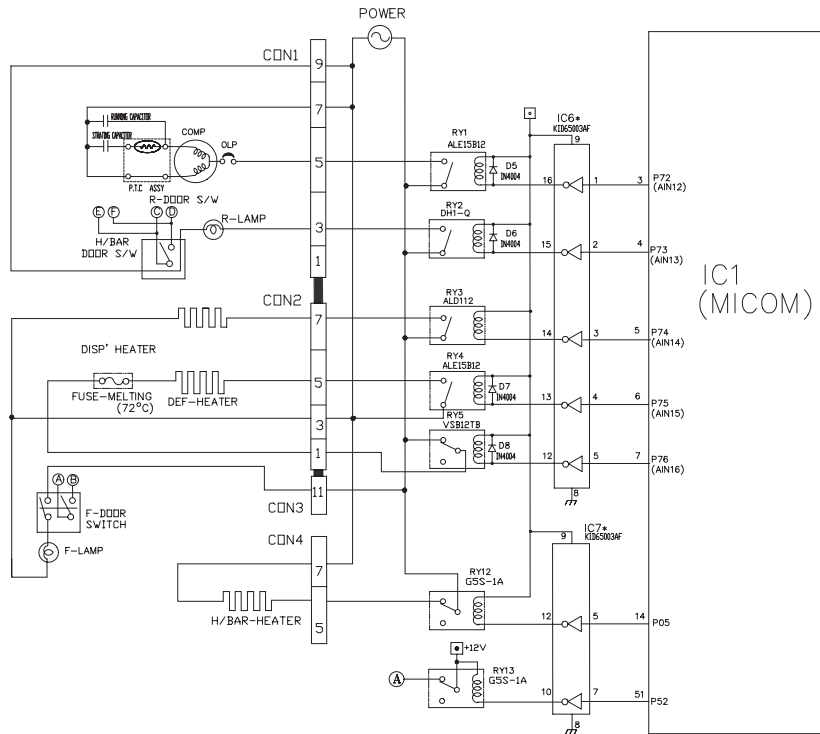

(4) GR-L267BV(T,S)PA (Refer to appendix)

Type of Load	Compressor	Frost Removal Heater	AC Converting Relay	Refrigerator LAMP	Dispenser Heater
Measuring part (IC6)	IC6-15	IC6-11	IC6-10	IC6-14	IC6-12
Status	ON	Within 1 V			
	OFF	12 V			

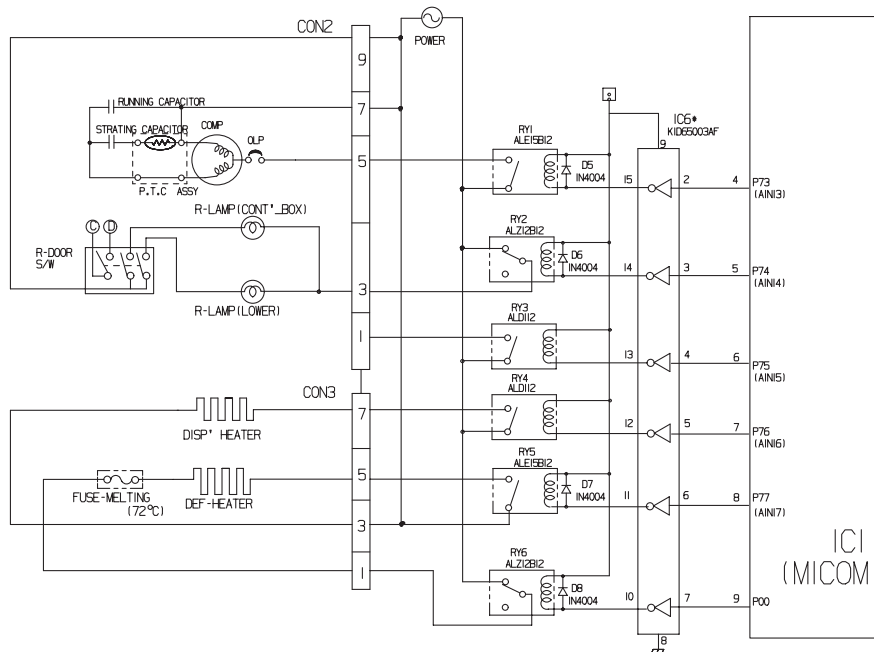

EXPLANATION FOR MICOM CIRCUIT

2. Dispenser operation circuit

(1) GR-L267BV(T)R, BNRV (Refer to appendix)

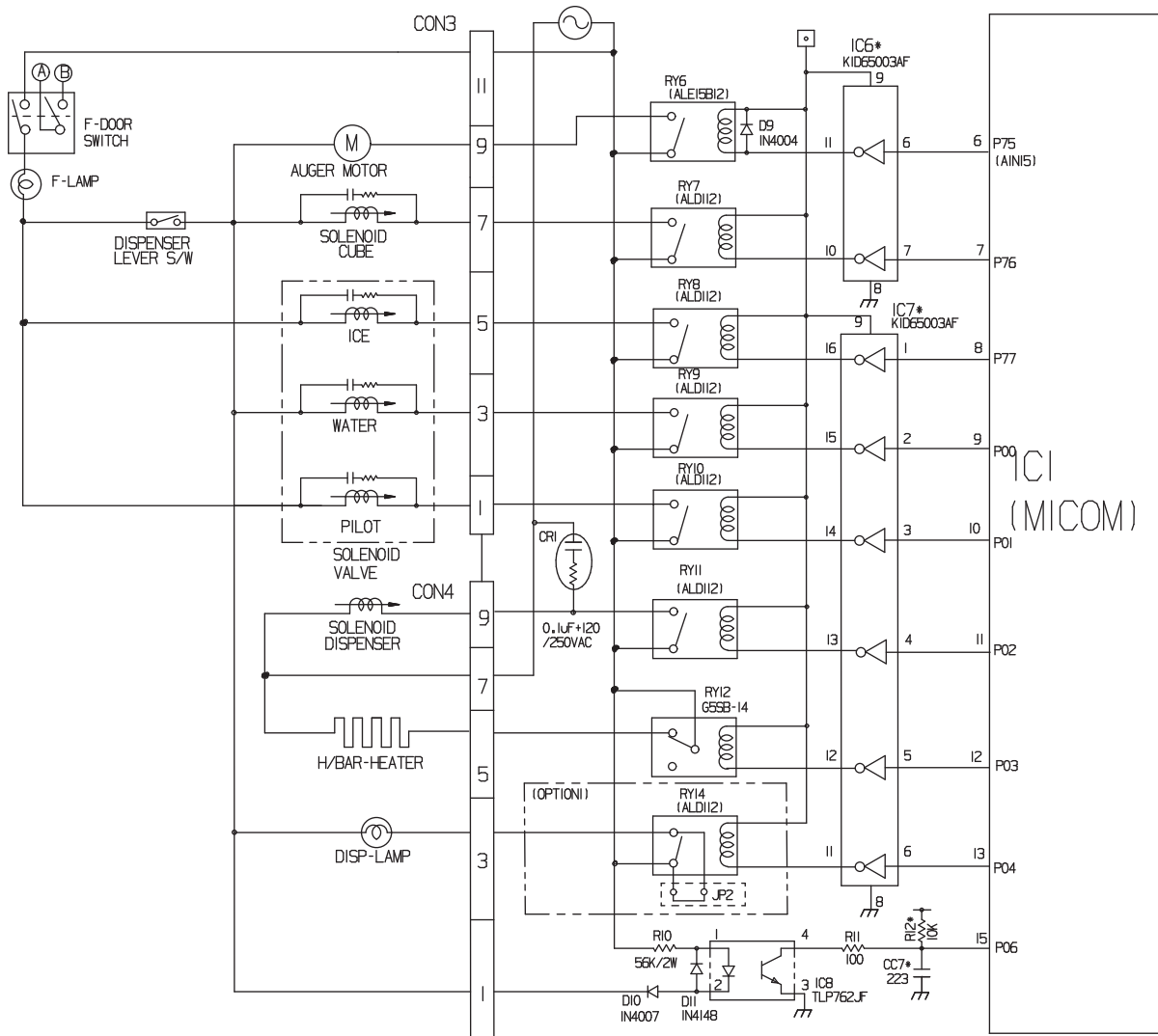

1) Check load driving status

Type of Load	GEARED MOTOR	SOLENOID CUBE	WATER VALVE	SOLENOID DISPENSER
			WATER	
Measuring part	IC6-11	IC6-10	IC7-15	IC7-13
Status	ON	Within 1 V		
	OFF	12 V		

2) Lever Switch sensing circuit

Measuring part	IC1(MICOM) (No. 16)	
Lever S/W		
ON (Press)	5 V	(60 Hz)
OFF	0 V	5V

EXPLANATION FOR MICOM CIRCUIT

(2) GR-L267BV(T)RA (Refer to appendix)

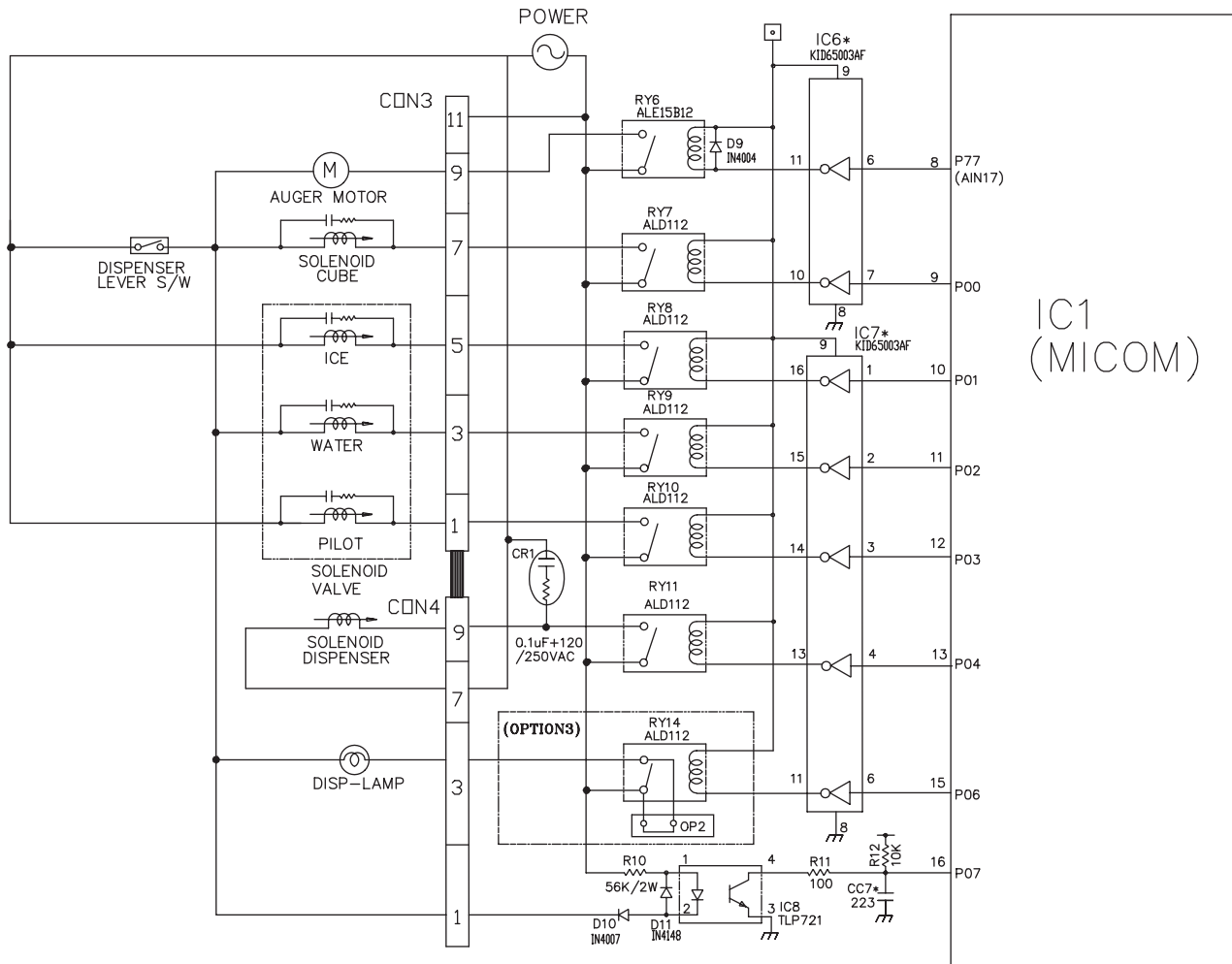

1) Check load driving status

Type of Load	GEARED MOTOR	SOLENOID CUBE	WATER VALVE		SOLENOID DISPENSER
			WATER		
Measuring part	IC6-11	IC6-10	IC7-15		IC7-13
Status	ON	Within 1 V			
	OFF	12 V			

2) Lever Switch sensing circuit

Measuring part	IC1(MICOM) (No. 16)	
Lever S/W		
ON (Press)	5 V	(60 Hz)
OFF	0 V	5V

EXPLANATION FOR MICOM CIRCUIT

(3) GR-L267BV(T,S)PA (Refer to appendix)

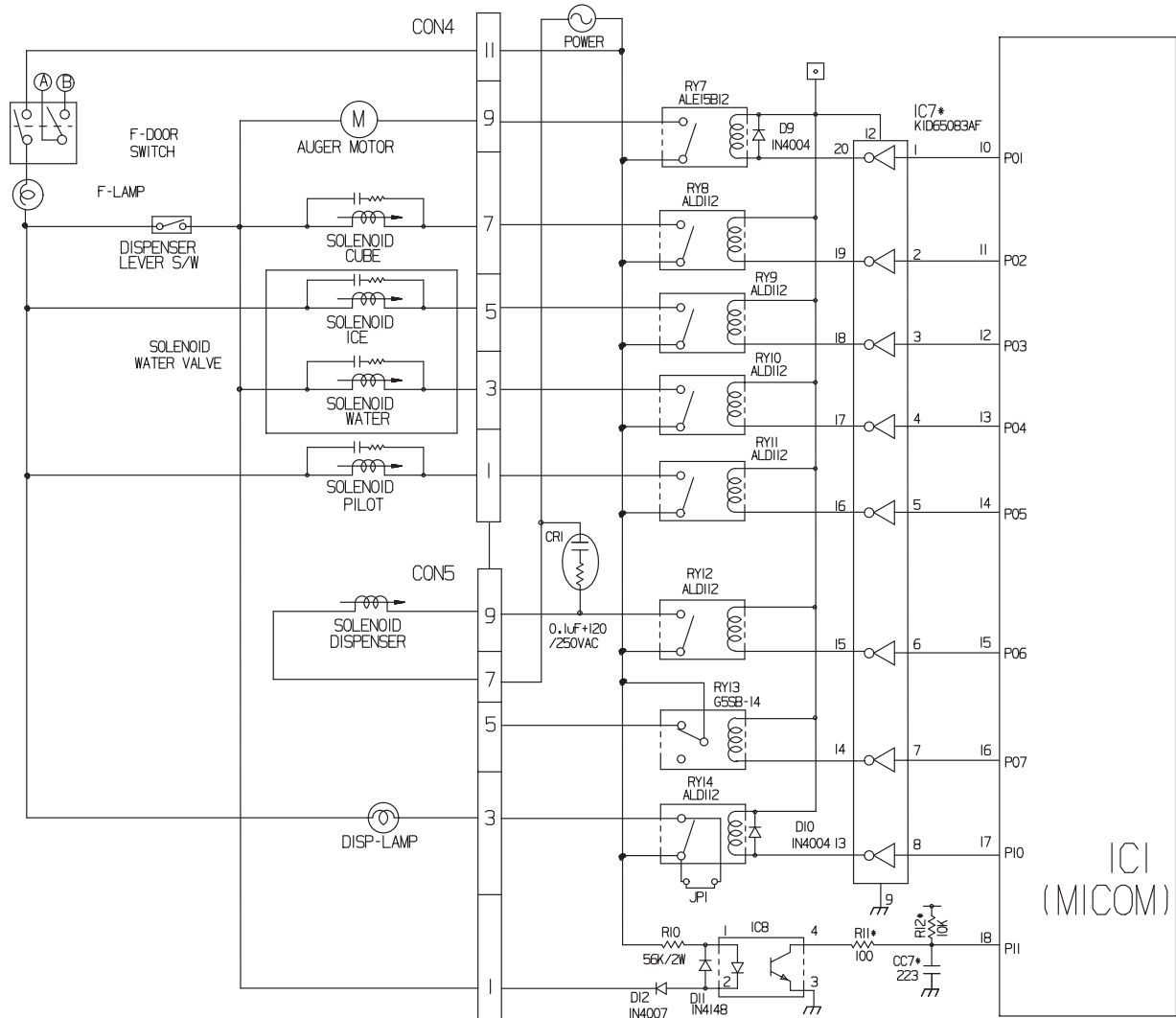

1) Check load driving status

Type of Load	GEARED MOTOR	SOLENOID CUBE	WATER VALVE	SOLENOID DISPENSER
			WATER	
Measuring part	IC7-20	IC7-19	IC7-17	IC7-15
Status	ON	Within 1 V		
	OFF	12 V		

2) Lever Switch sensing circuit

Measuring part	IC1(MICOM) (No. 16)	
Lever S/W		
ON (Press)	5 V	(60 Hz)
OFF	0 V	5V

EXPLANATION FOR MICOM CIRCUIT

3. Door opening sensing circuit

(1) GR-L267BV(T)R, BNRV (Refer to appendix)

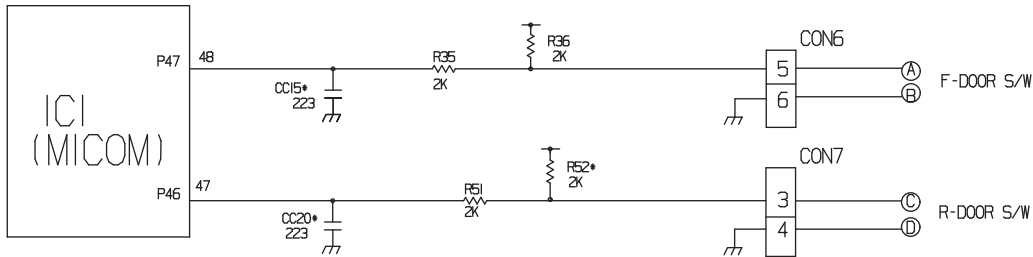

(2) GR-L267BV(T)RA (Refer to appendix)

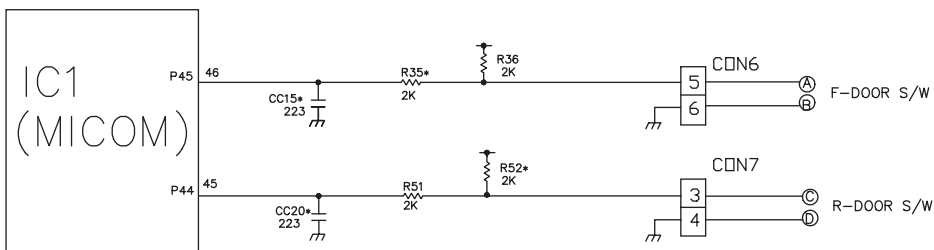

(3) GR-L267BV(T,S)PA (Refer to appendix)

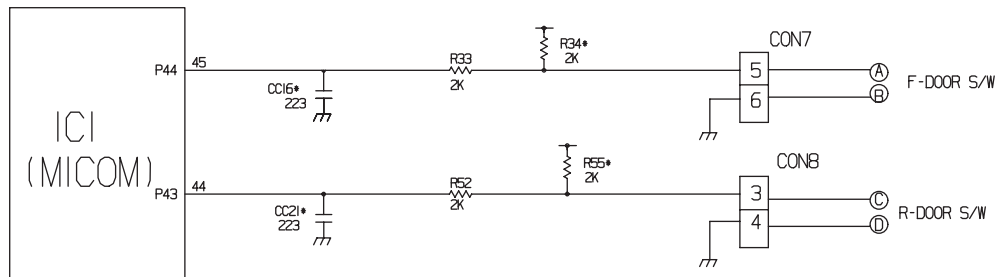

Measuring part	IC1 (MICOM) No. (44, 45) / (45, 46) / (47, 48) Pin
Door of Freezer / Refrigerator	
Closing	5 V (A) - (B), (C) - (D) . Switch at both ends are at OFF status)
Opening	0 V (A) - (B), (C) - (D) . Switch at both ends are at ON status)

* Since door switches (A) and (B) are interconnected, if either fails, the other will not respond properly.

* If either switch fails, the light will not come on.

EXPLANATION FOR MICOM CIRCUIT

1-5. Temperature sensing circuit

(1) GR-L267BV(T)R, BNRV (Refer to appendix)

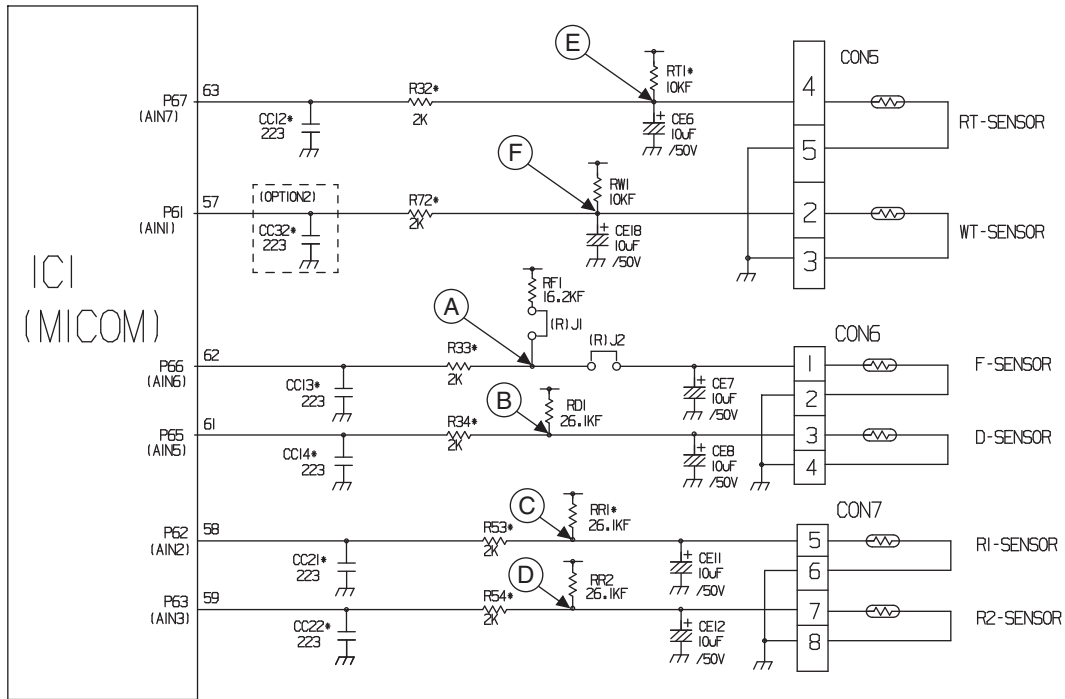

(2) GR-L267BV(T)RA (Refer to appendix)

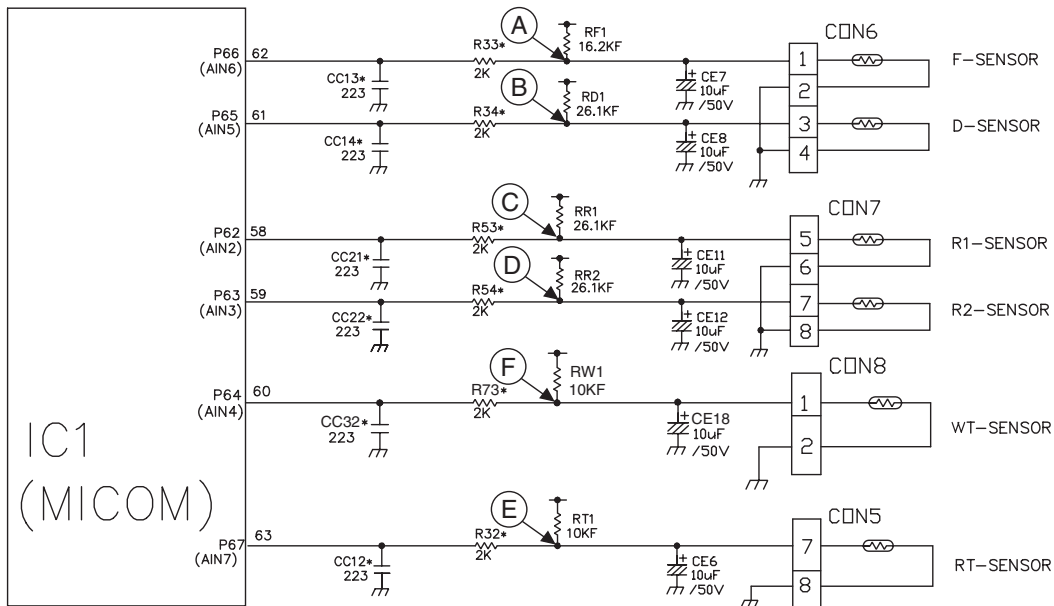

EXPLANATION FOR MICOM CIRCUIT

(3) GR-L267BV(T,S)PA (Refer to appendix)

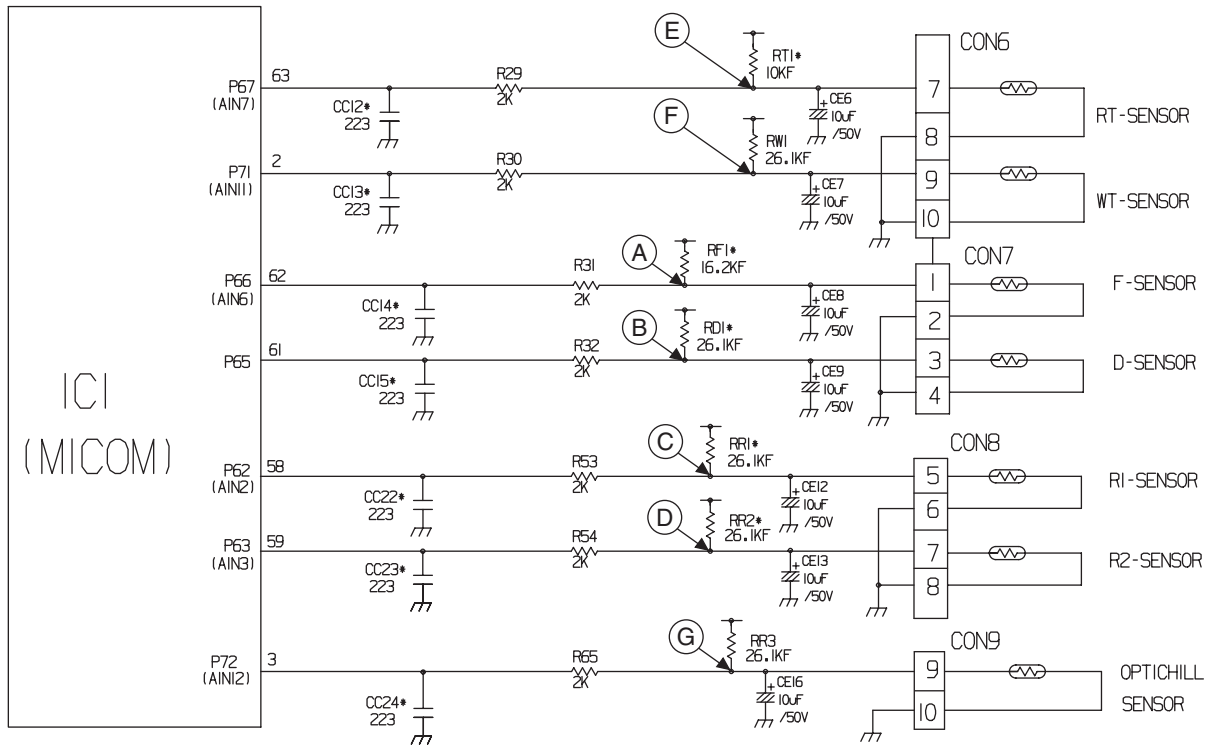

The circuits involving the freezer and refrigerator sensors control the temperature in both the freezer and the refrigerator. The Icemaker sensor detects when ice is made. The defrost sensor determines both the need for defrosting and the efficiency of the defrost operation. See the table below for voltages and checkpoints.

SENSOR	CHECK POINT	NORMAL(-30 °C ~ 50 °C)	IN SHORT	IN OPEN
Freezing sensor	POINT (A) Voltage	0.5 V~4.5 V	0 V	5 V
Defrost sensor	POINT (B) Voltage			
Refrigerator sensor 1	POINT (C) Voltage			
Refrigerator sensor 2	POINT (D) Voltage			
Room temperature sensor	POINT (E) Voltage			
Water tank sensor	POINT (F) Voltage			
Optichill sensor	POINT (G) Voltage			

EXPLANATION FOR MICOM CIRCUIT

1-6. Switch entry circuit

The following circuits are sensing signals from the test switch, damper motor reed switch for testing and diagnosing the refrigerator.

(1) GR-L267BV(T)R, BNRV (Refer to appendix)

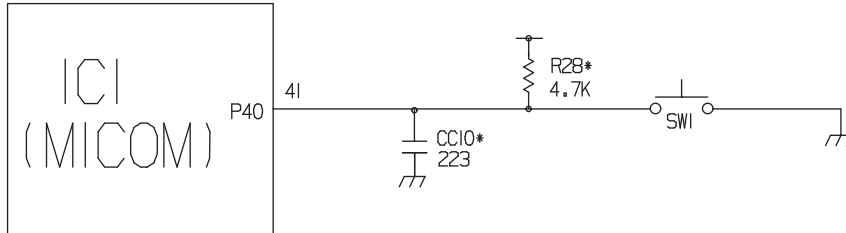

(2) GR-L267BV(T)RA (Refer to appendix)

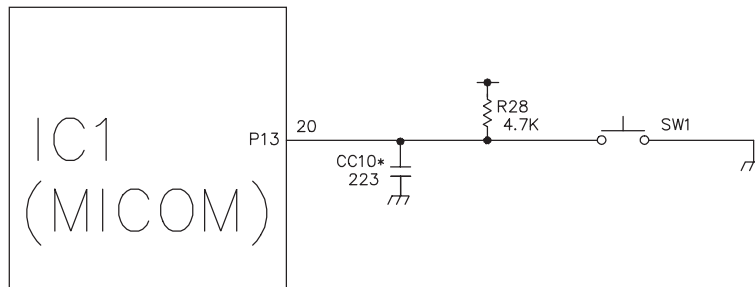

(3) GR-L267BV(T,S)PA (Refer to appendix)

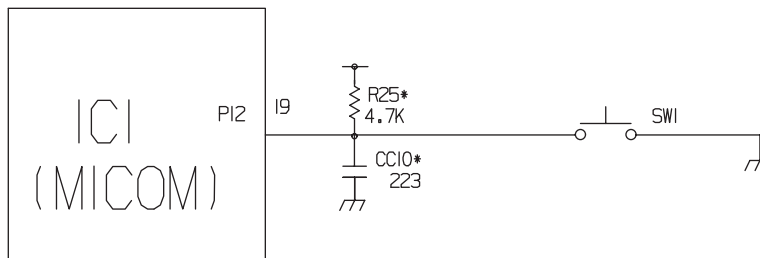

EXPLANATION FOR MICOM CIRCUIT

1-7. Option designation circuit (model separation function)

(1) GR-L267BV(T)RA (Refer to appendix)

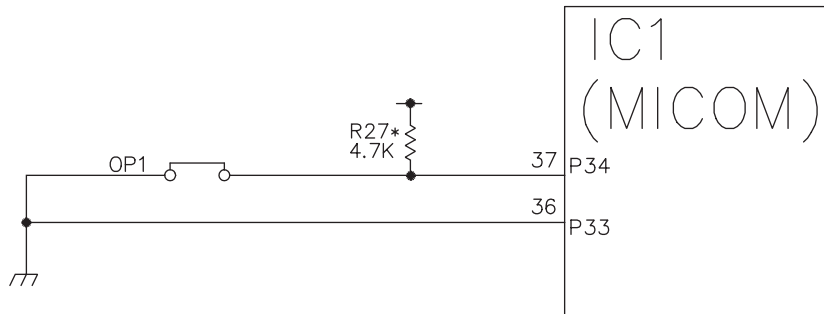

(2) GR-L267BV(T,S)PA (Refer to appendix)

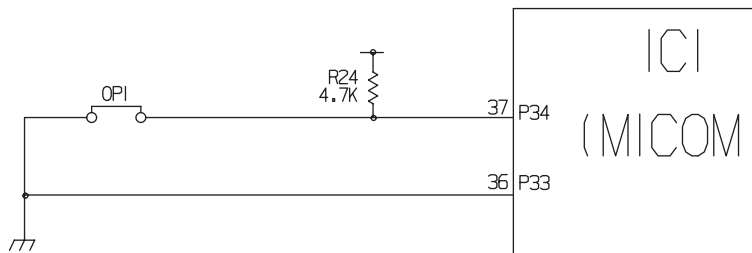

The circuits shown above may vary by model.

►These circuits are preset at the factory and cannot be altered.

EXPLANATION FOR MICOM CIRCUIT

1-8. Stepping motor operation circuit

(1) GR-L267BV(T)R, BNRV (Refer to appendix)

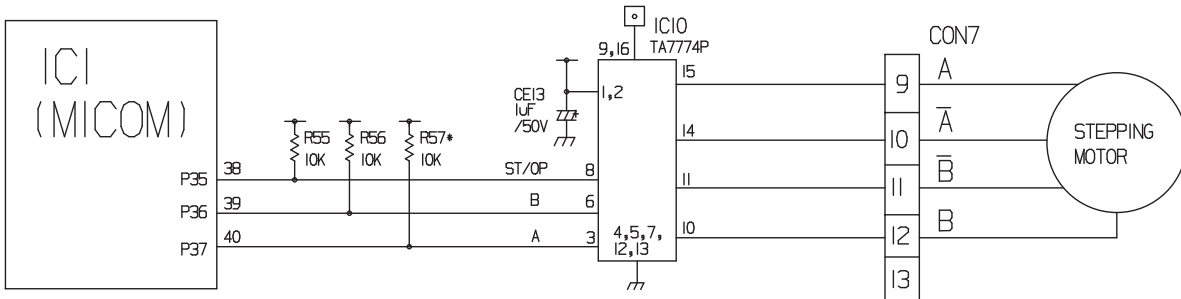

(2) GR-L267BV(T)RA (Refer to appendix)

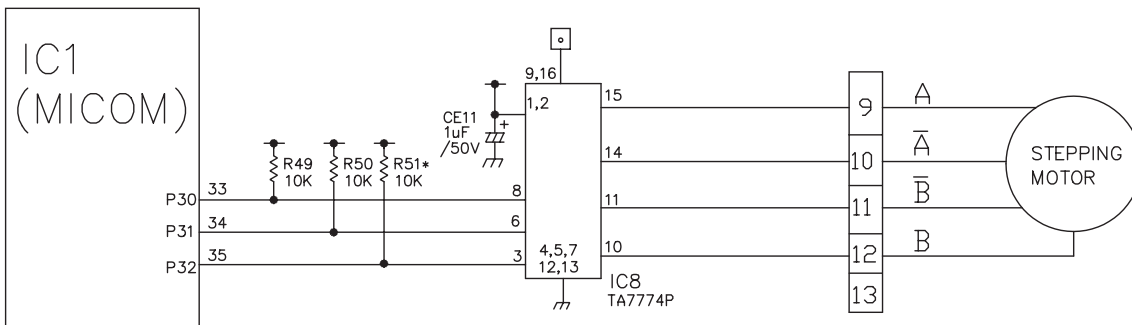

(3) GR-L267BV(T,S)PA (Refer to appendix)

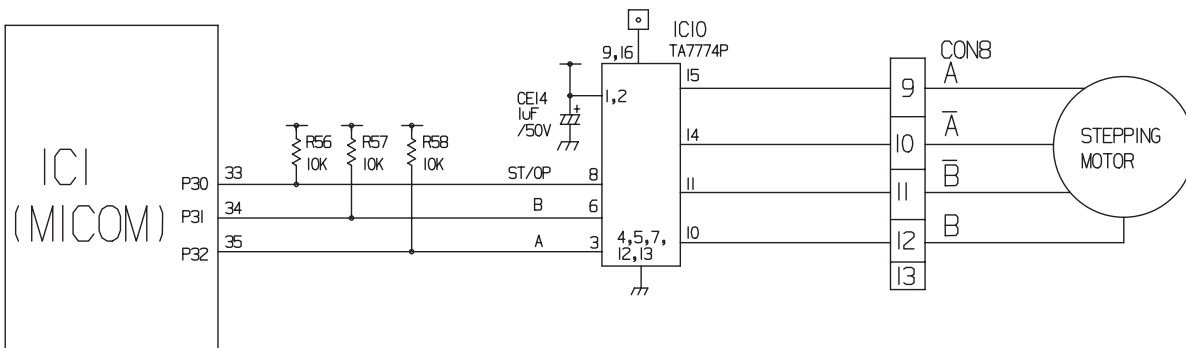

EXPLANATION FOR MICOM CIRCUIT

The motor is driven by magnetism formed in the areas of the coils and the stator. Rotation begins when a HIGH signal is applied to MICOM Pin 33 of IC10 (TA7774F). This causes an output of HIGH and LOW signals on MICOM pins 34 and 35.

Explanation) The stepping motor is driven by sending signals of 3.33 mSEC via MICOM pins 33, 34, and 35, as shown in the chart below. These signals are output via terminals 10, 11, 14, and 15 via input terminals 3, 6, and 8 of IC10 (TA7774F), the motor drive chip. The output signals allow the coils wound on each phase of the stator to form a magnetic field, which causes rotation. Input to the terminals INA and INB of IC10 as shown in the chart below drives the motor.

CCW (Reverse rotation) ← → (Positive rotation) CW

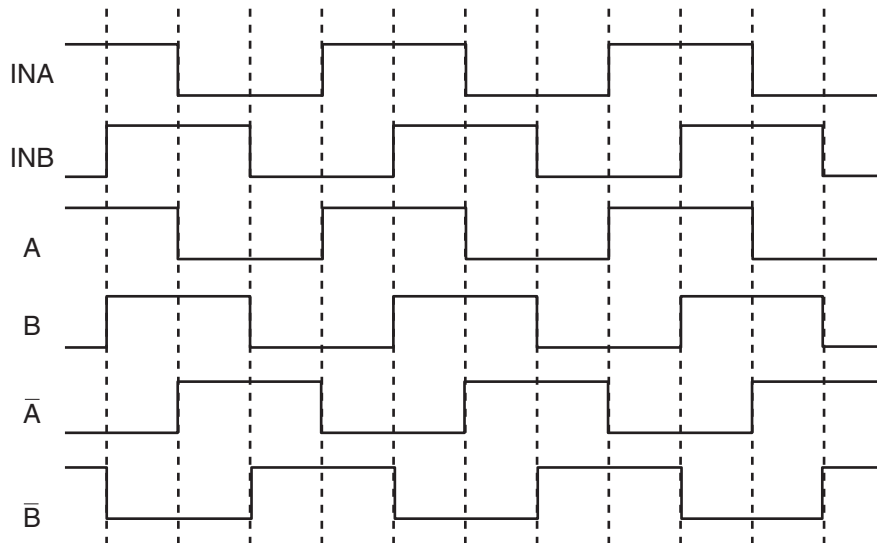

EXPLANATION FOR MICOM CIRCUIT

1-9. Fan motor driving circuit (freezer, mechanical area)

1. The circuit cuts all power to the fan drive IC, resulting in a standby mode.
2. This circuit changes the speed of the fan motor by varying the DC voltage between 7.5 Vdc and 16 Vdc.
3. This circuit stops the fan motor by cutting off power to the fan when it senses a lock-up condition.

	Ⓐ, Ⓓ part	Ⓑ part	Ⓔ part
Motor OFF	5V	2V or less	2V or less
Motor ON	2 ~ 3V	12 ~ 14V	8 ~ 16V

(1) GR-L267BV(T)R (Refer to appendix)

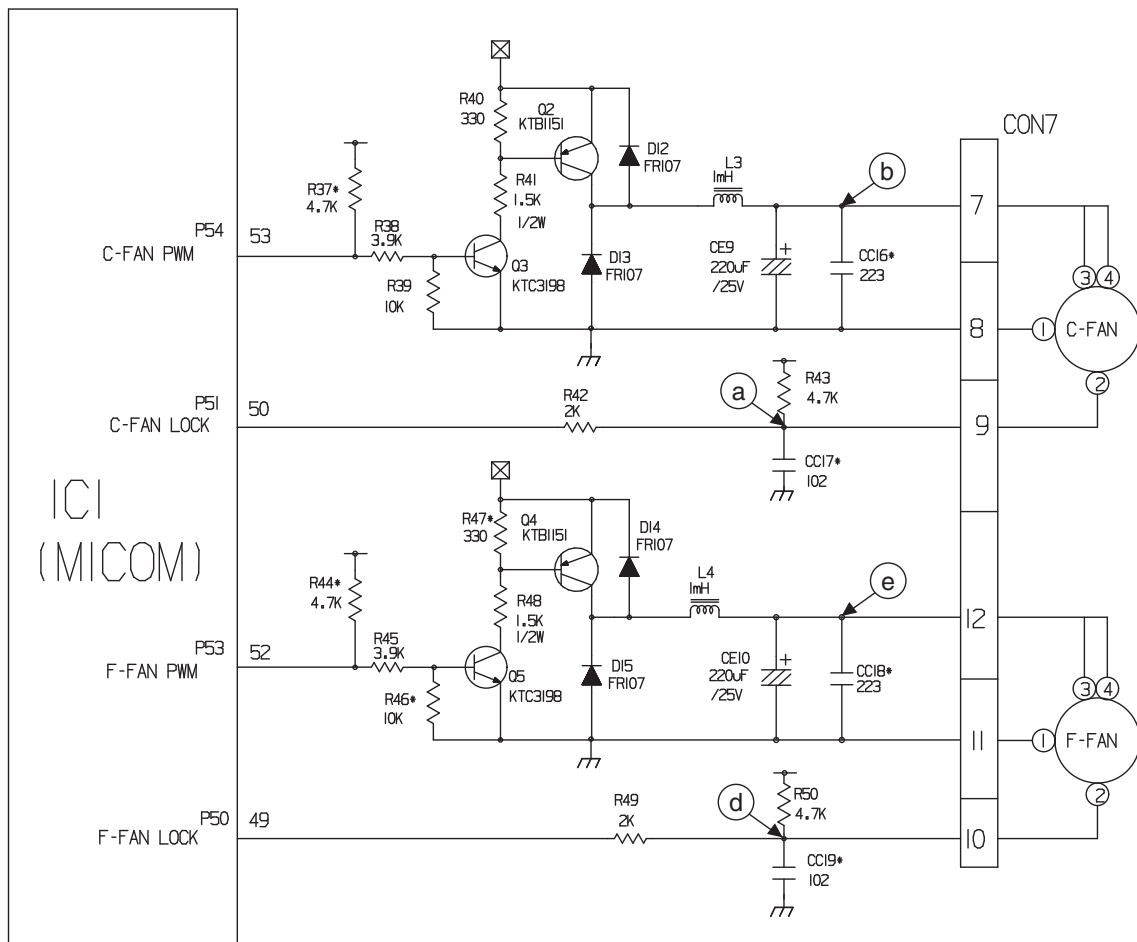

EXPLANATION FOR MICOM CIRCUIT

(2) GR-L267BNRY (Refer to appendix)

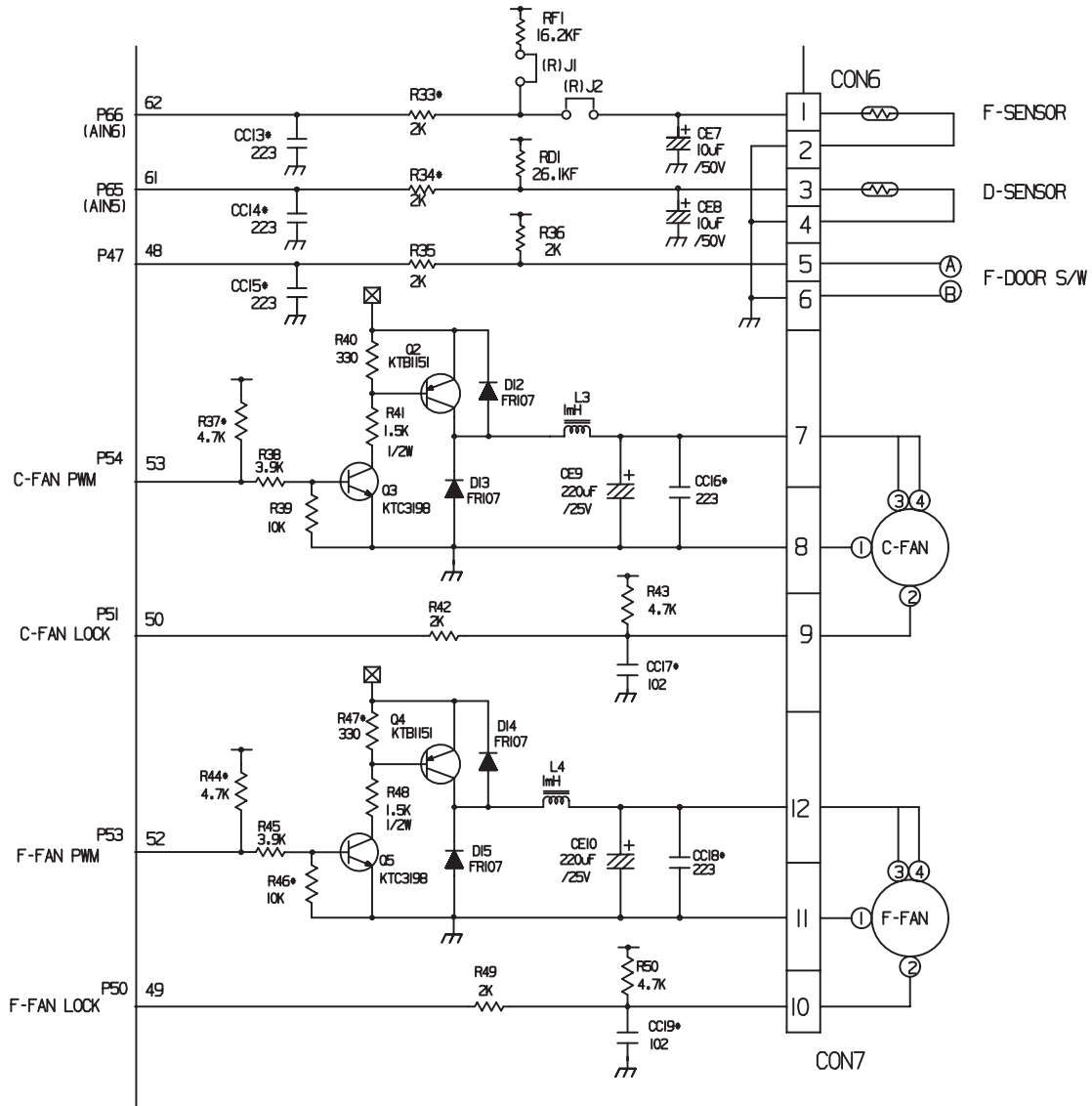

EXPLANATION FOR MICOM CIRCUIT

(3) GR-L267BV(T)RA (Refer to appendix)

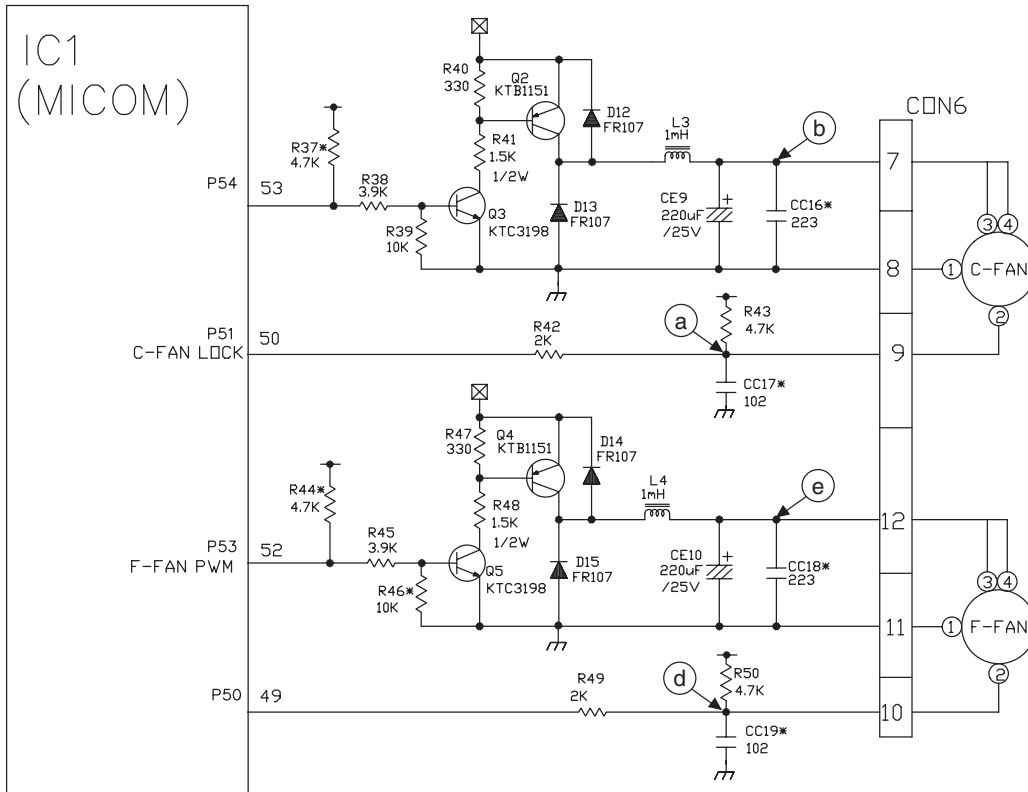

(4) GR-L267BV(T,S)PA (Refer to appendix)

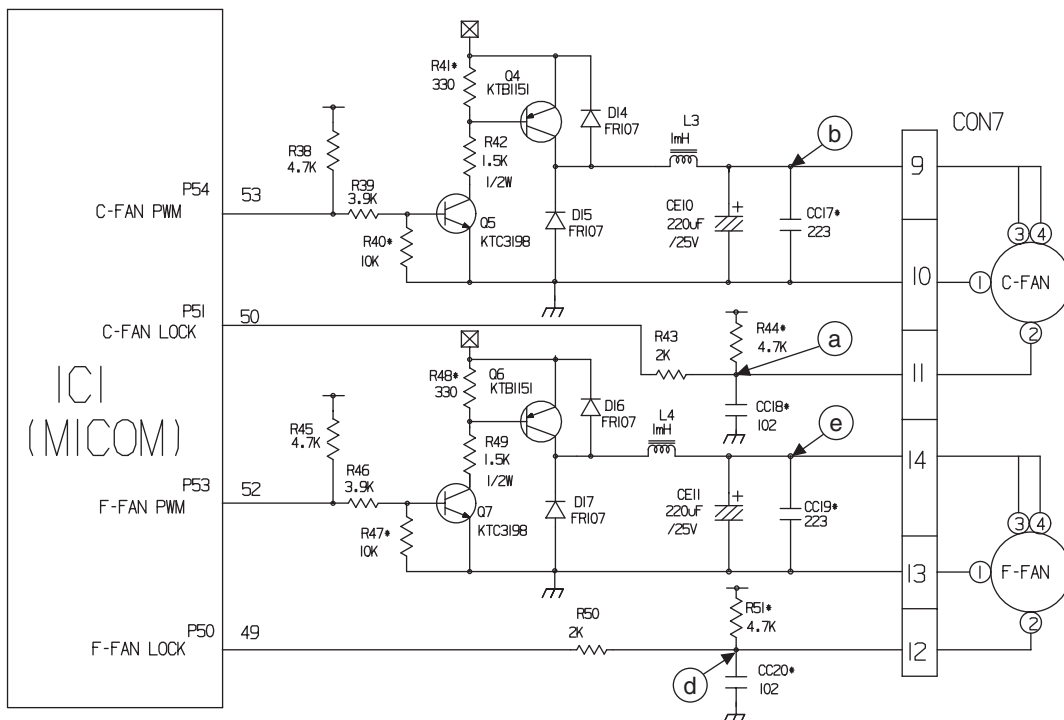

EXPLANATION FOR MICOM CIRCUIT

1-10. Temperature compensation and temperature compensation circuit

1. Temperature compensation in freezer and refrigerator

(1) GR-L267BV(T)R (Refer to appendix)

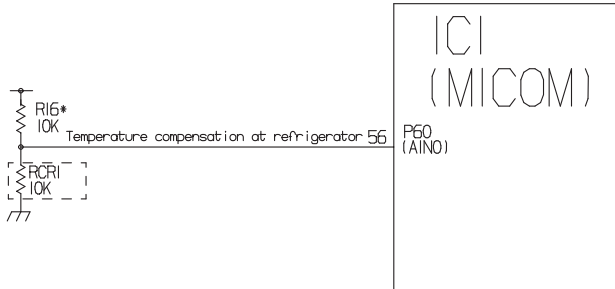

(2) GR-L267BV(T)RA (Refer to appendix)

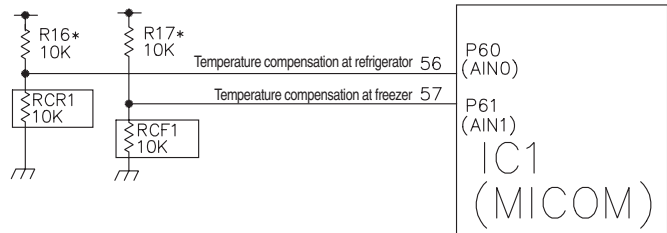

(3) GR-L267BV(T,S)PA (Refer to appendix)

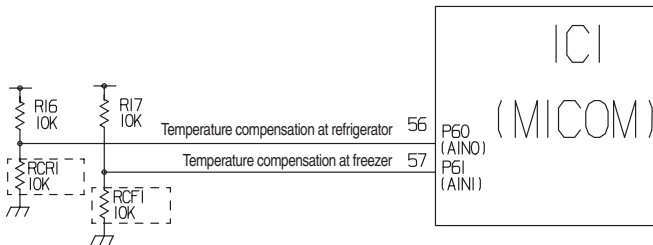

Freezer		Refrigerator		Remarks
Resistance value (RCF1)	Temperature compensation	Resistance value (RCR1)	Temperature compensation	
180 kΩ	+5 °C [+9°F]	180 kΩ	+2.5 °C [+4.5°F]	↑ Warmer
56 kΩ	+4 °C [+7.2°F]	56 kΩ	+2.0 °C [+3.6°F]	
33 kΩ	+3 °C [+5.4°F]	33 kΩ	+1.5 °C [+2.7°F]	
18 kΩ	+2 °C [+3.6°F]	18 kΩ	+1.0 °C [+1.8°F]	
12 kΩ	+1 °C [+1.8°F]	12 kΩ	+0.5 °C [+0.9°F]	
10 kΩ	0 °C [0°F]	10 kΩ	0 °C [0°F]	Reference temperature
8.2 kΩ	-1 °C [-1.8°F]	8.2 kΩ	-0.5 °C [-0.9°F]	↓ Cooler
5.6 kΩ	-2 °C [-3.6°F]	5.6 kΩ	-1.0 °C [-1.8°F]	
3.3 kΩ	-3 °C [-5.4°F]	3.3 kΩ	-1.5 °C [-2.7°F]	
2 kΩ	-4 °C [-7.2°F]	2 kΩ	-2.0 °C [-3.6°F]	
470 Ω	-5 °C [-9°F]	470 Ω	-2.5 °C [-4.5°F]	

► Temperature compensation table by adjustment value (difference value against current temperature)

Ex) If you change compensation resistance at the refrigerator (RCR1) from 10 kΩ (current resistance) to 18 kΩ (modified resistance), the temperature at the refrigerator will increase by +1°C[+1.8°F].

EXPLANATION FOR MICOM CIRCUIT

► Temperature compensation table at the refrigerator is as follows:

	Modification resistance Current resistance	470 Ω	2 kΩ	3.3 kΩ	5.6 kΩ	8.2 kΩ	10 kΩ	12 kΩ	18 kΩ	33 kΩ	56 kΩ	180 kΩ
		Refrigerator (RCR1)	470Ω	No change	0.5 °C [0.9 °F] Up	1 °C [1.8 °F] Up	1.5 °C [2.7 °F] Up	2 °C [3.6 °F] Up	2.5 °C [4.5 °F] Up	3 °C [5.4 °F] Up	3.5 °C [6.3 °F] Up	4 °C [7.2 °F] Up
2 kΩ	0.5 °C [0.9 °F] Down		No change	0.5 °C [0.9 °F] Up	1 °C [1.8 °F] Up	1.5 °C [2.7 °F] Up	2 °C [3.6 °F] Up	2.5 °C [4.5 °F] Up	3 °C [5.4 °F] Up	3.5 °C [6.3 °F] Up	4 °C [7.2 °F] Up	4.5 °C [8.1 °F] Up
3.3 kΩ	1 °C [1.8 °F] Down		0.5 °C [0.9 °F] Down	No change	0.5 °C [0.9 °F] Up	1 °C [1.8 °F] Up	1.5 °C [2.7 °F] Up	2 °C [3.6 °F] Up	2.5 °C [4.5 °F] Up	3 °C [5.4 °F] Up	3.5 °C [6.3 °F] Up	4 °C [7.2 °F] Up
5.6 kΩ	1.5 °C [2.7 °F] Down		1 °C [1.8 °F] Down	0.5 °C [0.9 °F] Down	No change	0.5 °C [0.9 °F] Up	1 °C [1.8 °F] Up	1.5 °C [2.7 °F] Up	2 °C [3.6 °F] Up	2.5 °C [4.5 °F] Up	3 °C [5.4 °F] Up	3.5 °C [6.3 °F] Up
8.2 kΩ	2 °C [3.6 °F] Down		1.5 °C [2.7 °F] Down	1 °C [1.8 °F] Down	0.5 °C [0.9 °F] Drop	No change	0.5 °C [0.9 °F] Up	1 °C [1.8 °F] Up	1.5 °C [2.7 °F] Up	2 °C [3.6 °F] Up	2.5 °C [4.5 °F] Up	3 °C [5.4 °F] Up
10 kΩ	2.5 °C [4.5 °F] Down		2 °C [3.6 °F] Down	1.5 °C [2.7 °F] Down	1 °C [1.8 °F] Down	0.5 °C [0.9 °F] Down	No change	0.5 °C [0.9 °F] Up	1 °C [1.8 °F] Up	1.5 °C [2.7 °F] Up	2 °C [3.6 °F] Up	2.5 °C [4.5 °F] Up
12 kΩ	3 °C [5.4 °F] Down		2.5 °C [4.5 °F] Down	2 °C [3.6 °F] Down	1.5 °C [2.7 °F] Down	1 °C [1.8 °F] Down	0.5 °C [0.9 °F] Down	No change	0.5 °C [0.9 °F] Up	1 °C [1.8 °F] Up	1.5 °C [2.7 °F] Up	2 °C [3.6 °F] Up
18 kΩ	3.5 °C [6.3 °F] Down		3 °C [5.4 °F] Down	2.5 °C [4.5 °F] Down	2 °C [3.6 °F] Down	1.5 °C [2.7 °F] Down	1 °C [1.8 °F] Down	0.5 °C [0.9 °F] Down	No change	0.5 °C [0.9 °F] Up	1 °C [1.8 °F] Up	1.5 °C [2.7 °F] Up
33 kΩ	4 °C [7.2 °F] Down		3.5 °C [6.3 °F] Down	3 °C [5.4 °F] Down	2.5 °C [4.5 °F] Down	2 °C [3.6 °F] Down	1.5 °C [2.7 °F] Down	1 °C [1.8 °F] Down	0.5 °C [0.9 °F] Down	No change	0.5 °C [0.9 °F] Up	1 °C [1.8 °F] Up
56 kΩ	4.5 °C [8.1 °F] Down		4 °C [7.2 °F] Down	3.5 °C [6.3 °F] Down	3 °C [5.4 °F] Down	2.5 °C [4.5 °F] Down	2 °C [3.6 °F] Down	1.5 °C [2.7 °F] Down	1 °C [1.8 °F] Down	0.5 °C [0.9 °F] Down	No change	0.5 °C [0.9 °F] Up
180 kΩ	5 °C [9 °F] Down	4.5 °C [8.1 °F] Down	4 °C [7.2 °F] Down	3.5 °C [6.3 °F] Down	3 °C [5.4 °F] Down	2.5 °C [4.5 °F] Down	2 °C [3.6 °F] Down	1.5 °C [2.7 °F] Down	1 °C [1.8 °F] Down	0.5 °C [0.9 °F] Down	No change	

► Temperature compensation at the freezer is performed the same as at the refrigerator. The value for the freezer is twice that of the refrigerator.

► This circuit enters the necessary level of temperature compensation for adjusting the appliance. The method is the same for every model in this appliance family.

EXPLANATION FOR MICOM CIRCUIT

2. Compensation circuit for temperature at freezer

(1) GR-L267BV(T)RA (Refer to appendix)

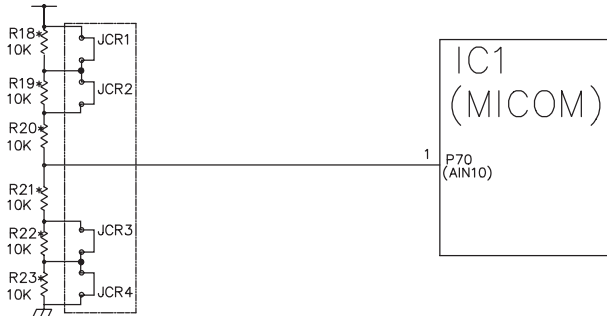

(2) GR-L267BV(T,S)PA (Refer to appendix)

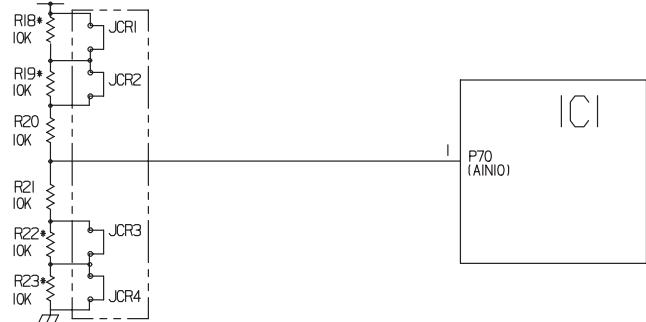

Temperature compensation in CUT		
JCR1	+1 °C [+1.8 °F]	+2 °C [+3.6 °F]
JCR2	+1 °C [+1.8 °F]	
JCR3	-1 °C [-1.8 °F]	-2 °C [-3.6 °F]
JCR4	-1 °C [-1.8 °F]	

Compensation for weak-cold		Compensation for over-cold		Temperature compensation value at refrigerator	Remarks
JCR3	JCR4	JCR1	JCR2		
<input type="checkbox"/>	<input type="checkbox"/>	<input type="checkbox"/>	<input type="checkbox"/>	0 °C (In shipment from factory)	
CUT	<input type="checkbox"/>	<input type="checkbox"/>	<input type="checkbox"/>	-1 °C [-1.8 °F]	
<input type="checkbox"/>	CUT	<input type="checkbox"/>	<input type="checkbox"/>	-1 °C [-1.8 °F]	
<input type="checkbox"/>	<input type="checkbox"/>	CUT	<input type="checkbox"/>	+1 °C [+1.8 °F]	
<input type="checkbox"/>	<input type="checkbox"/>	<input type="checkbox"/>	CUT	+1 °C [+1.8 °F]	
CUT	CUT	<input type="checkbox"/>	<input type="checkbox"/>	-2 °C [-3.6 °F]	
<input type="checkbox"/>	<input type="checkbox"/>	CUT	CUT	+2 °C [+3.6 °F]	
CUT	<input type="checkbox"/>	CUT	<input type="checkbox"/>	0 °C [0 °F]	
CUT	<input type="checkbox"/>	<input type="checkbox"/>	CUT	0 °C [0 °F]	
<input type="checkbox"/>	CUT	CUT	<input type="checkbox"/>	0 °C [0 °F]	
<input type="checkbox"/>	CUT	<input type="checkbox"/>	CUT	0 °C [0 °F]	
CUT	CUT	CUT	<input type="checkbox"/>	-1 °C [-1.8 °F]	
<input type="checkbox"/>	CUT	CUT	CUT	+1 °C [+1.8 °F]	
CUT	CUT	CUT	CUT	0 °C [0 °F]	

► This circuit allows adjustment of the set temperature for compensation by changing jumpers at locations JCR1~JCR4.

EXPLANATION FOR MICOM CIRCUIT

1-11. Communication circuit and connection Lead Wire between main PCB and display PCB

The following communication circuit is used for exchanging information between the main MICOM of the Main PCB and the dedicated MICOM of the LED (LCD) Display PCB.

A bi-directional lead wire assembly between the two boards is required for the display to function properly.

Poor communication occurs if a continuous information exchange fail to continue for more than 2 minutes between main MICOM of main PCB and LCD (LED) dedicated MICOM for LCD (LED) control of display PCB.

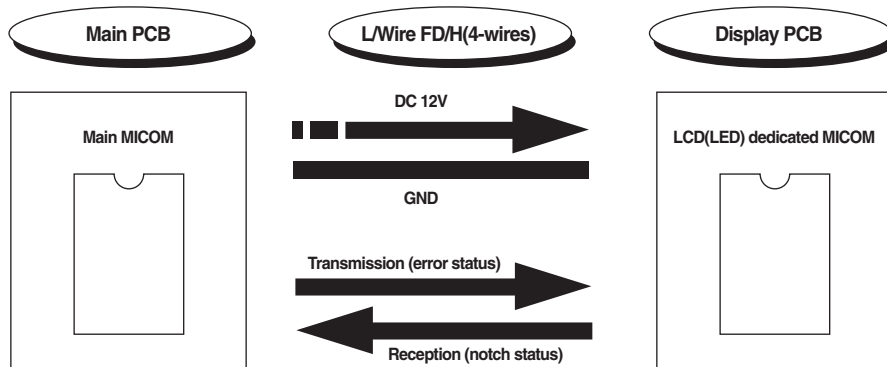

(1) GR-L267BV(T)R, BNRV (Refer to appendix)

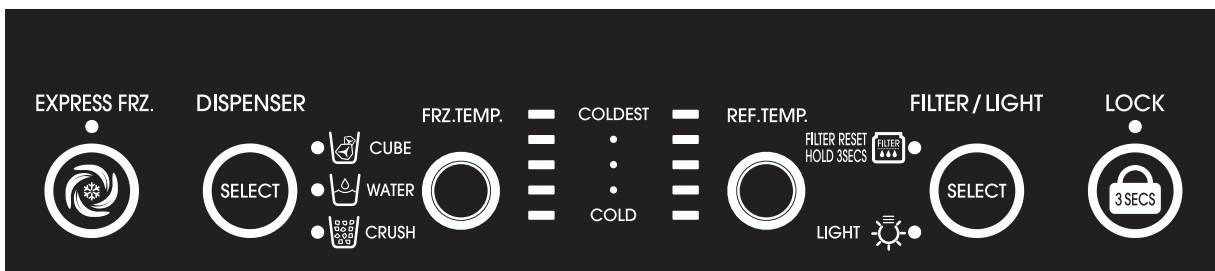
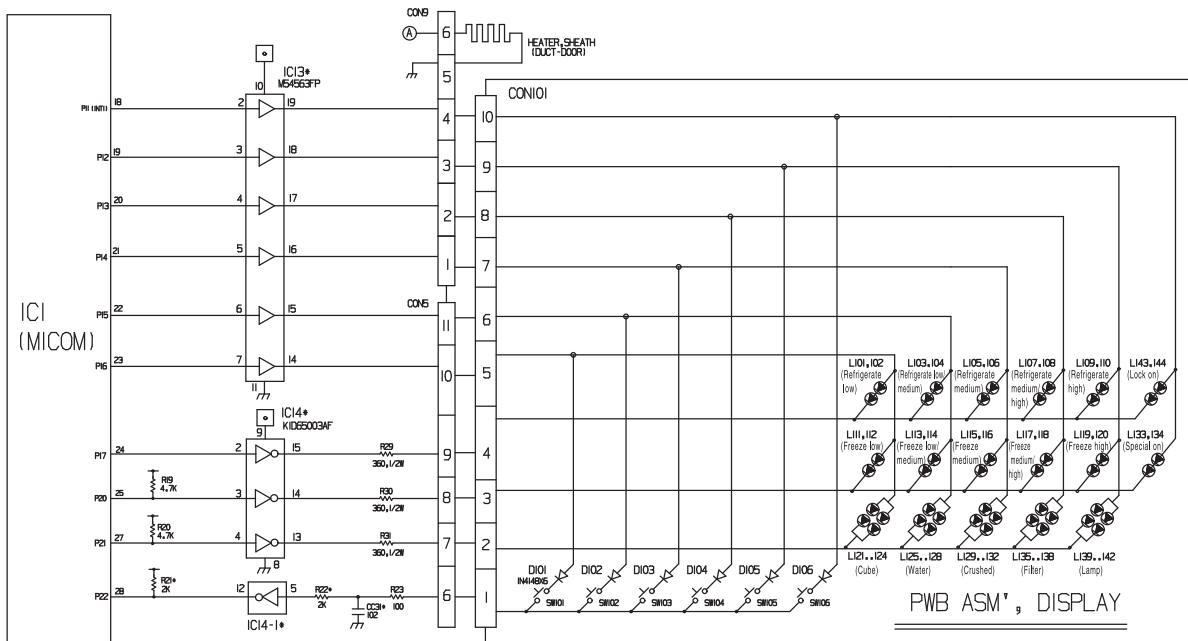

EXPLANATION FOR MICOM CIRCUIT

(2) GR-L267BV(T)RA (Refer to appendix)

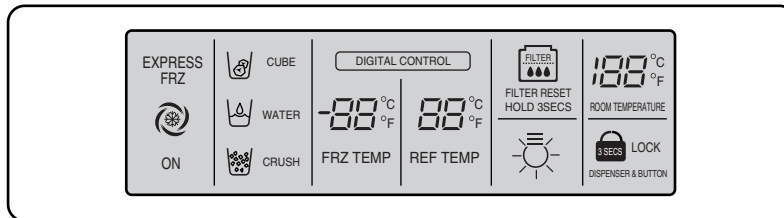
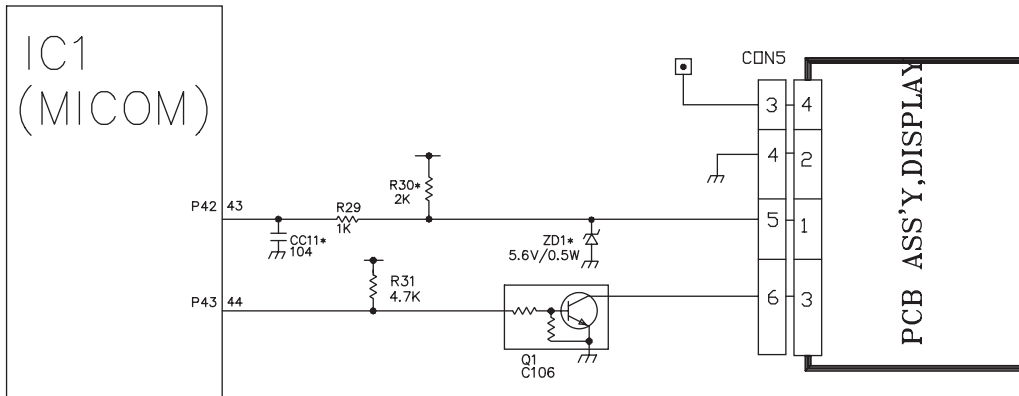

(3) GR-L267BV(T,S)PA (Refer to appendix)

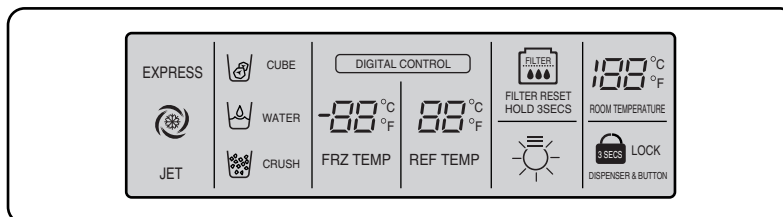
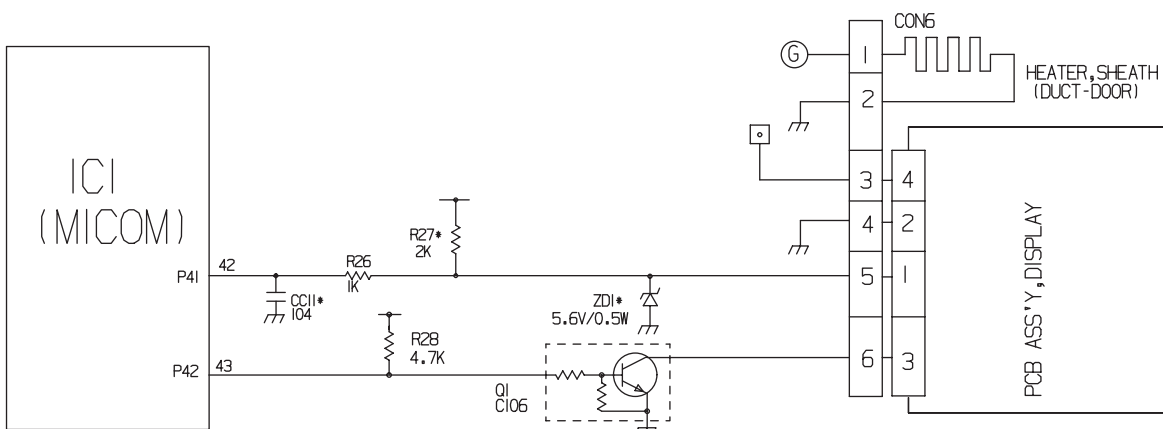

EXPLANATION FOR MICOM CIRCUIT

2) Sensor resistance characteristics table

Measuring Temperature (°C)	Measuring Temperature (°F)	Freezing Sensor	Cold storage sensor 1 & 2 Frost removal sensor, Outside sensor
-20 °C	-4 °F	22.3 kΩ	77 kΩ
-15 °C	+5 °F	16.9 kΩ	60 kΩ
-15 °C	+14 °F	13.0 kΩ	47.3 kΩ
-5 °C	+23 °F	10.1 kΩ	38.4 kΩ
0 °C	+32 °F	7.8 kΩ	30 kΩ
+5 °C	+41 °F	6.2 kΩ	24.1 kΩ
+10 °C	+50 °F	4.9 kΩ	19.5 kΩ
+15 °C	+59 °F	3.9 kΩ	15.9 kΩ
+20 °C	+68 °F	3.1 kΩ	13 kΩ
+25 °C	+77 °F	2.5 kΩ	11 kΩ
+30 °C	+86 °F	2.0 kΩ	8.9 kΩ
+40 °C	+104 °F	1.4 kΩ	6.2 kΩ
+50 °C	+122°F	0.8 kΩ	4.3 kΩ

- ▶ Resistance value allowance of sensor is ±5%.
- ▶ When measuring the resistance value of the sensor, allow the temperature of that sensor to stabilize for at least 3 minutes before measuring. This delay is necessary because of the sense speed relationship.
- ▶ Use a digital tester to measure the resistance. An analog tester has to great a margin of error.
- ▶ Resistance of the cold storage sensor 1 and 2 shall be measured with a digital tester after separating CON8 of the PWB ASSEMBLY and the MAIN part.
- ▶ Resistance of the freezing sensor shall be measured with a digital tester after separating CON7 of the PWB ASSEMBLY and the MAIN part.

EXPLANATION FOR MICOM CIRCUIT

1-12. OptiChill stepping MOTOR/Display

(1) GR-L267BV(T,S)PA (Refer to appendix)

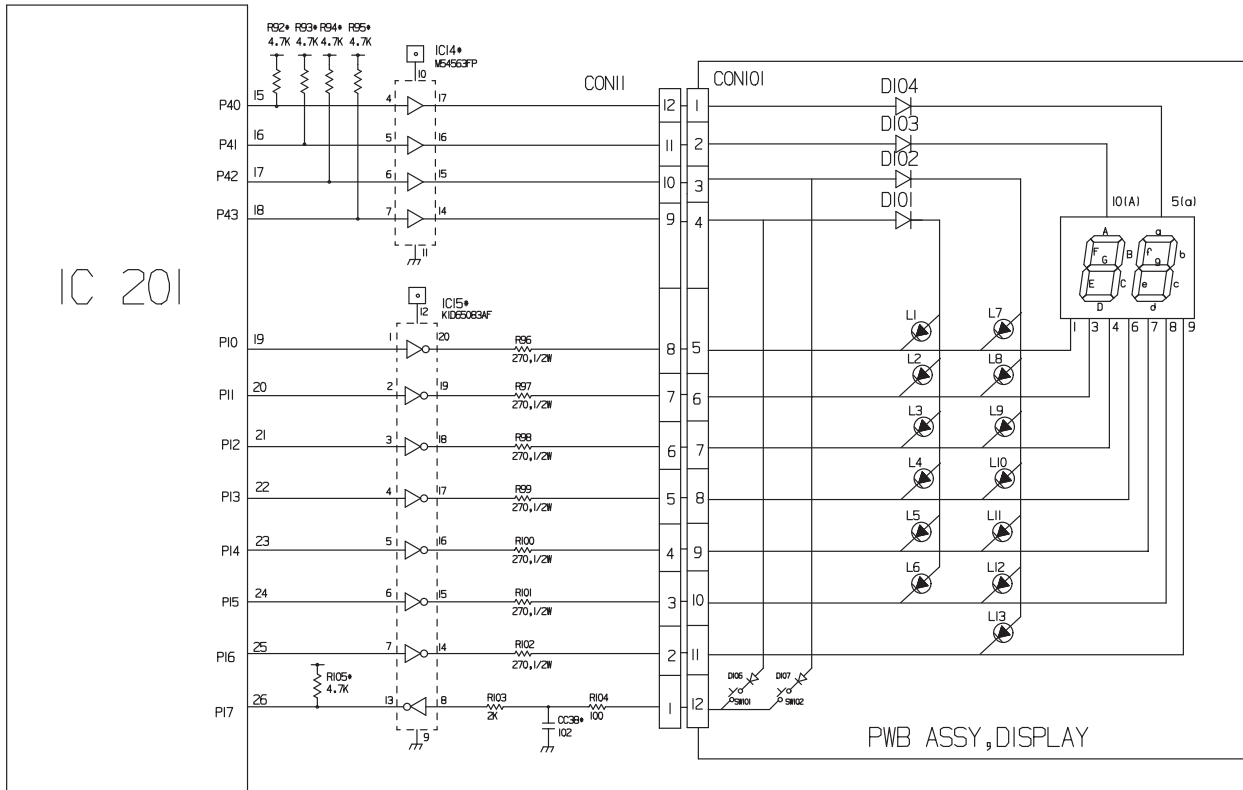
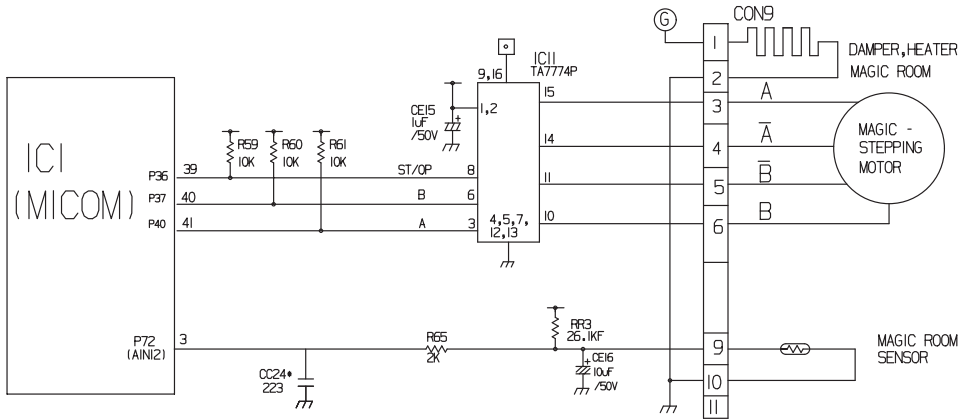

1-13. Jet Freezing

(1) GR-L267BV(T,S)PA (Refer to appendix)

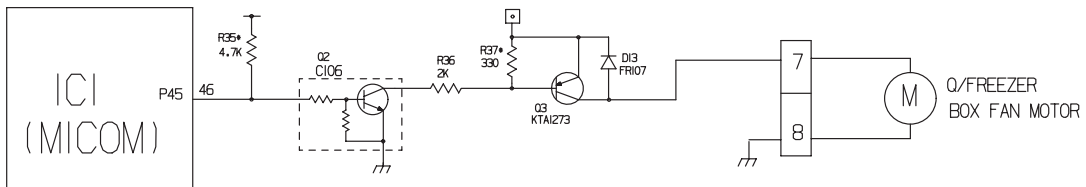

EXPLANATION FOR MICOM CIRCUIT

2. PWB parts diagram and list

2-1. PWB Assembly, main part diagram

(1) GR-L267BV(T)R (Refer to appendix)

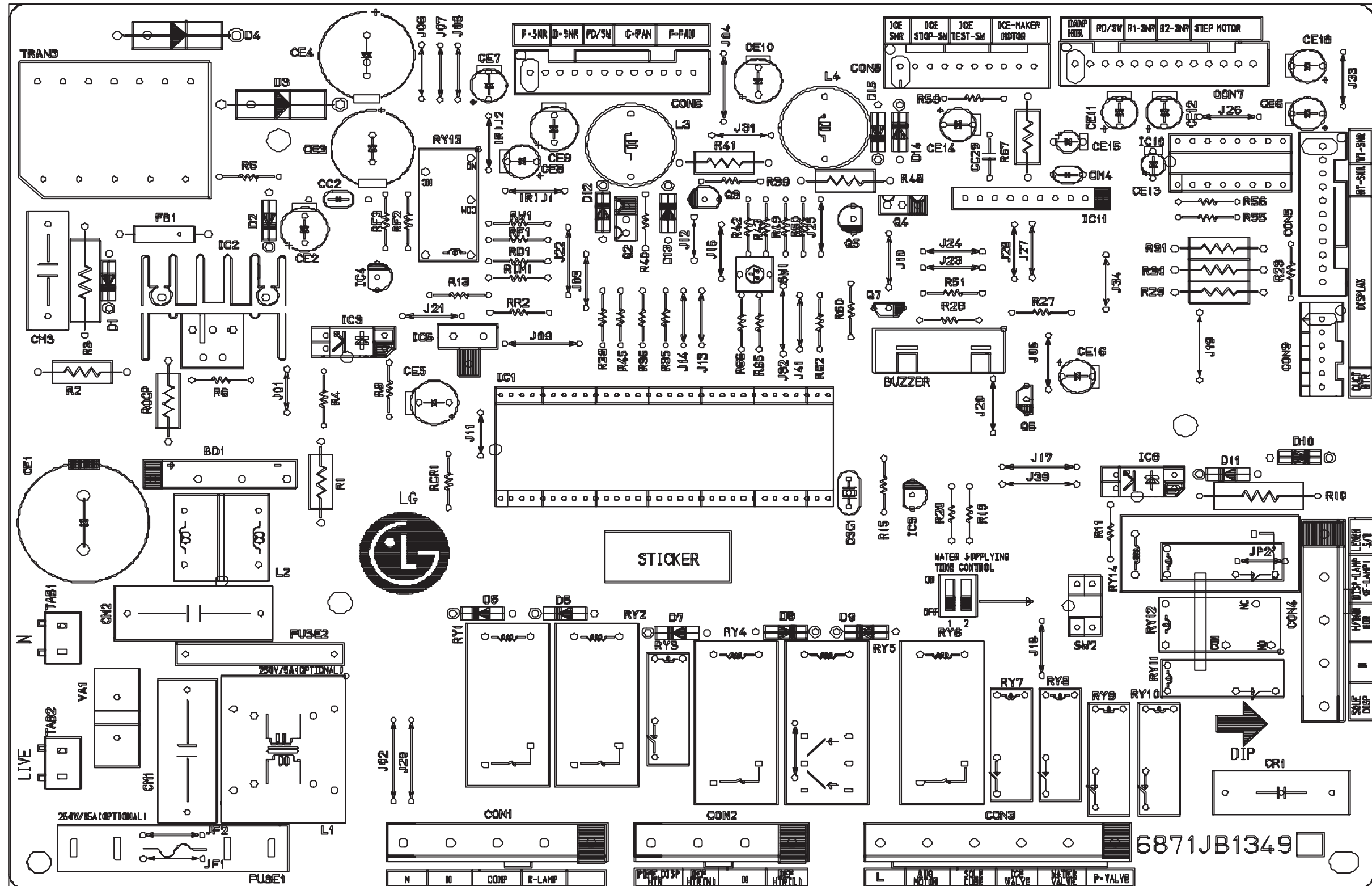

EXPLANATION FOR MICOM CIRCUIT

(2) GR-L267BV(T)RA (Refer to appendix)

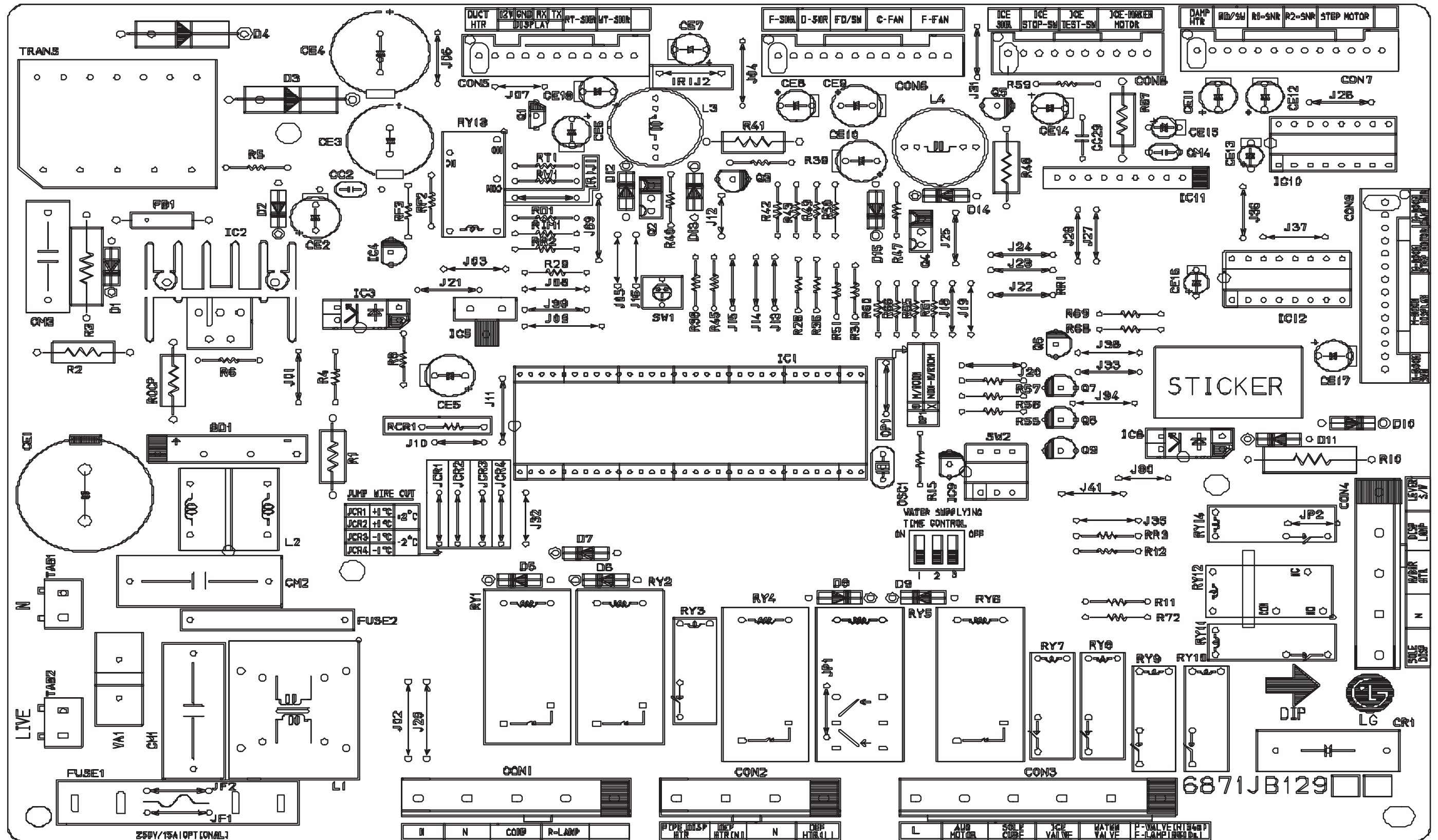

EXPLANATION FOR MICOM CIRCUIT

(3) GR-L267BV(T,S)PA (Refer to appendix)

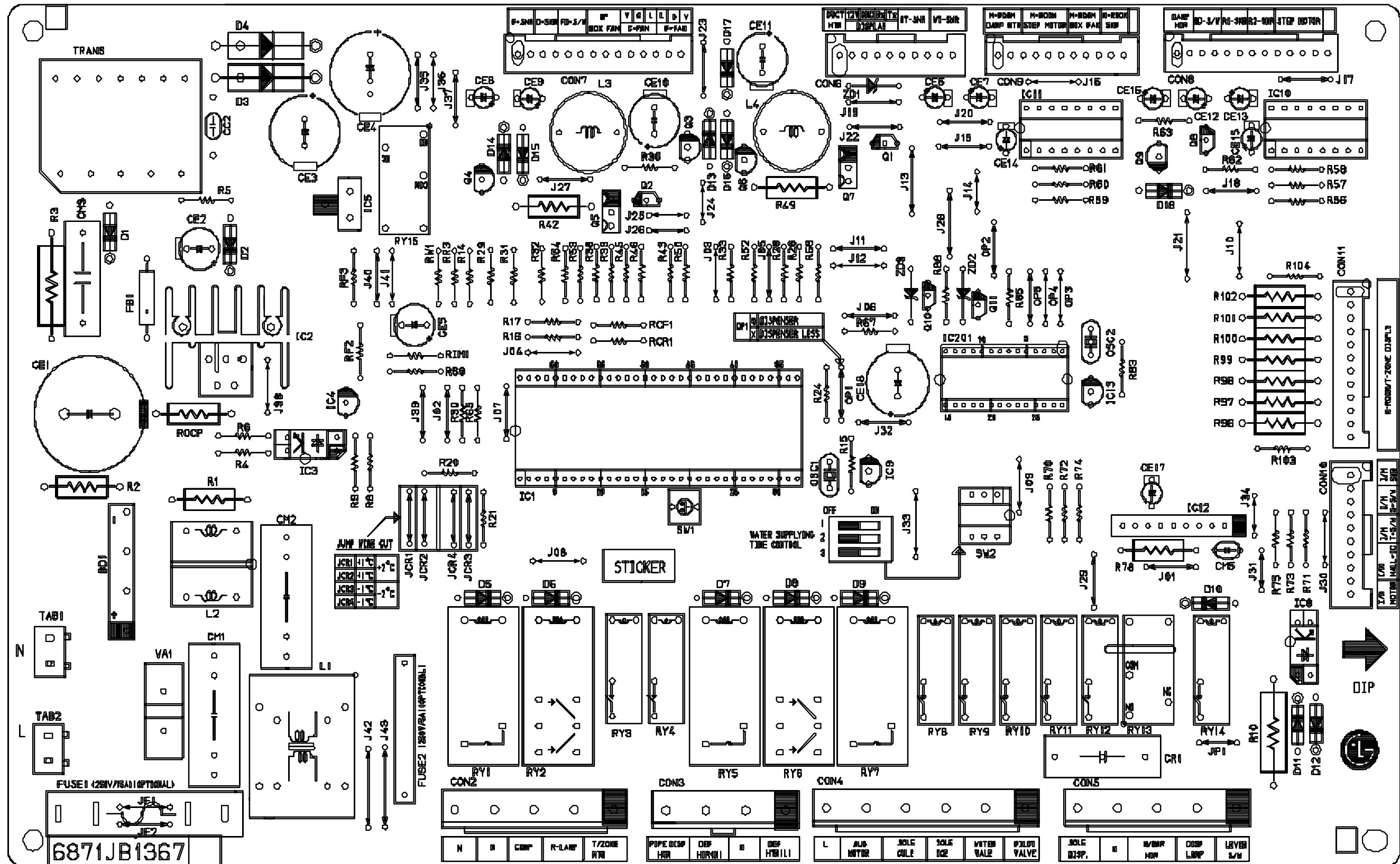

EXPLANATION FOR MICOM CIRCUIT

2-2. Parts list

(1) GR-L267BV(T)R (Refer to appendix)

No	P/NO	DESCRIPTION	SPEC	MAKER	REMARK
1	6870_BB179B	PWB(PCB)	L/P267*R CHD-PJT UL NON-M/ROOM VER-2	DOO SAN	T=1,6(NON-MAGIC ROOM)
2	6170_BB2013C	TRANSFORMER,SMP3 COIL I	CD2/CH-PJT DELUXE NAESJ	SAM IL	TRANS
2	6170_BB2013D	TRANSFORMER,SMP3 COIL I	CD2/CH-PJT DELUXE 100-127V	SAM IL	TRANS
3	6630W02707	CONNECTOR (CIRC),WAFER	YW396 YEONHO 7P 3.96MM (7P-2,4,6)	YEON HO	CON2
4	6630W00509	CONNECTOR (CIRC),WAFER	YW396 YEONHO 9P 3.96MM YW396-09AV RED	YEON HO	CON4
5	6630W02609	CONNECTOR (CIRC),WAFER	YW396 YEONHO 9P 3.96MM (9P-2,4,6,8)	YEON HO	CON1
6	6630W01111	CONNECTOR (CIRC),WAFER	YW396 YEONHO 11P 3.96MM YW396-11AV (11P-2,4,6,8,10)	YEON HO	CON3
7	6630_BB007K	CONNECTOR (CIRC),WAFER	917789-1 AMP 11P 2.5MM STRAIGHT SN	AMP	CON5
8	6630_BB007J	CONNECTOR (CIRC),WAFER	917788-1 AMP 10P 2.5MM STRAIGHT SN	AMP	CON8
9	6630_BB007L	CONNECTOR (CIRC),WAFER	917790-1 AMP 12P 2.5MM STRAIGHT SN	AMP	CON6
10	6630_BB010A	CONNECTOR (CIRC),WAFER	917791-1 AMP 13P 2.5MM STRAIGHT SN	AMP	CON7
11	6630_BB007E	CONNECTOR (CIRC),WAFER	917784-1 AMP 6P 2.5MM STRAIGHT SN	AMP	CON9
12	01ZZ_L0258B	IC,DRAWING	TM87PM41N 64P SDIP ST OTP TOMORROW-PJT N/S IBODEFN BETTERI	TOSHIBA	IC1
13	O1PMGSK001A	IC,POWER MANAGEMENT	STR-G635IL SANKEN SPIN T0220 ST SMP3 I CHIP	SANKEN	IC2
14	O1PMGNE001A	IC,POWER MANAGEMENT	PS2561-1 NEC 4P,DIP BK : TLP762.F	NEC	IC3,8
15	O1KE431000A	IC,KEC	K1A431 3 PIN TP - -	KEC	IC4
16	O1KE780500W	IC,LINEAR	K1A7805PI - - - -	KEC	IC5
17	O1KE650030C	IC,KEC	K1D65003AF 16SOP BK 7CH DRIVER	KEC	IC6,7
18	O1KE704200A	IC,KEC	K1A7042P KEC 3P BK RESET	KEC	IC9
19	O1T0777400A	IC,DRAWING	TA7774AP 16,SDIP BK DRIVE,IC STEPPING MOTOR	TOSHIBA	IC10
20	O1RH622200A	IC,ROHM	BAG222 10SIP BK REVERSIBLE MOTOR DRIVER	ROHM	IC11
21	O1RH934600D	IC,ROHM	BR93LC46RF-W 8PIN SOP BK EEPROM	ROHM	IC12
22	O1STLM001A	IC,STANDARD LOGIC	M64563FP MITSUBISHI 20 R/T CONVERT	MITSUBISHI	IC13
23	O1KE650030C	IC,KEC	K1D65003AF 16SOP BK 7CH DRIVER	KEC	IC14
24	6920000001A	RELAY	ALE15B12 MATSUSHITA 250VAC 16A 12VDC IA NO VENTING	MATSUSHITA	RY1,4,6
	6920_BB2005B	RELAY	G5J5-IA-NT OMRON 250VAC 16A 12VDC IA NO VENTING	OMRON	
	6920_BB2005C	RELAY	DHIU II DEC 250VAC 16A 12VDC IA VENTING	DAIICHI	
25	6920_BB2004D	RELAY	DH1ZD1-0-0 (JAPAN) DEC 250VAC 10A 12VDC IA NO VENTING	DAIICHI	RY2
	6920000001A	RELAY	ALE15B12 MATSUSHITA 250VAC 16A 12VDC IA NO VENTING	MATSUSHITA	RY2(EXPORT)
	6920_BB2005B	RELAY	G5J5-IA-NT OMRON 250VAC 16A 12VDC IA NO VENTING	OMRON	
	6920_BB2005C	RELAY	DHIU II DEC 250VAC 16A 12VDC IA VENTING	DAIICHI	
27	6920A90002A	RELAY	ALD12 MATSUSHITA 250VAC 3A 12VDC IA NO VENTING	MATSUSHITA	RY3,7,8,9,11
	6920_BB2003A	RELAY	G5N-1A OMRON 250VAC 1.5A 12VDC IA	OMRON	
28	6920A90002A	RELAY	ALD12 MATSUSHITA 250VAC 3A 12VDC IA NO VENTING	MATSUSHITA	RY10(PILOT)
	6920_BB2003A	RELAY	G5N-1A OMRON 250VAC 1.5A 12VDC IA	OMRON	
29	6920A90002A	RELAY	ALD12 MATSUSHITA 250VAC 3A 12VDC IA NO VENTING	MATSUSHITA	RY14(DISP'-LAMP)
	6920_BB2003A	RELAY	G5N-1A OMRON 250VAC 1.5A 12VDC IA	OMRON	
30	6920AL_Z001A	RELAY	ALZ12B12 NAIS 250VAC 16A 12VDC IC NO VENTING	NAIS	RY5
31	6920_BB2009B	RELAY	G55B-14 OMRON 250VAC 5A 12VDC IC NO-VENTING	OMRON	RY12(H/BARI)
32	6920_BB2009B	RELAY	G55B-14 OMRON 250VAC 5A 12VDC IC NO-VENTING	OMRON	RY13
33	6212_BB001B	RESONATOR,CERAMIC	CS750400MG03 MURATA 4MHZ - TP -	MURATA	OSC1
34	6102_BB001A	VARIATOR	SV0621D-14A SAMMHA UL/VDE BK 620V	SAW MHA, IL JIN	VA1
35	6102_BB001E	VARIATOR	SV06271D-14A SAMMHA UL/VDE BK 270V	SAW MHA, IL JIN	VA1
36	0DR107009AA	DIODE,RECTIFIERS	FR107 TP DELTA D041 1000V IA 3	DELTA	DI,2,12,13,14,15
37	0DRSA00090A	DIODE,RECTIFIERS	RL3 SANKEN BK NON 350V 3.5A 80A 50NSEC 0.1MA	SANKEN	D3
38	0DRSA00090A	DIODE,RECTIFIERS	RL3 SANKEN BK NON 350V 3.5A 80A 50NSEC 0.1MA	SANKEN	D4
39	0DRB30000AA	DIODE,RECTIFIERS	D358A60 BK SHINDENGEN 600V 4A	SHINDENGEN	D01
40	0DD400409AA	DIODE,RECTIFIERS	IN4004 PYUNG CHANG TP26 D041 400V IA 30A 75NS 5UA	DELTA,PYUNGCHANG	D5-9
41	0DD400709AA	DIODE,RECTIFIERS	IN4007 MOTOROLA TP D041 600V 1.5A 60A 75NS 10UA	DELTA,PYUNGCHANG	D10
42	0DD4148098B	DIODE,SWITCHING	IN4148 TP ROHM D035 75V 450MIL	ROHM,PYUNGCHANG	D11
43	0CE4762V6E0	CAPACITOR,FIXED ELECTROLYTIC	47UF HE 450V 20% BULK SNAP IN	RUBYCON,SAMMHA	CE1(105)
44	0CE686ZUGED	CAPACITOR,FIXED ELECTROLYTIC	68UF MXC 400V 20% BULK SNAP IN	RUBYCON,SAMMHA	CE1(105)
45	0CE226ZK638	CAPACITOR,FIXED ELECTROLYTIC	22UF YXA 50V 20% FM5 TP 5	RUBYCON,SAMMHA	CE2(105)
46	0CE108Z4610	CAPACITOR,FIXED ELECTROLYTIC	1000UF YXG 25V 20% FL BULK	RUBYCON,SAMMHA	CE3(105)
47	0CE108Z4610	CAPACITOR,FIXED ELECTROLYTIC	1000UF YXG 35V 20% FL BULK	RUBYCON,SAMMHA	CE4(105)
48	0CE227ZF638	CAPACITOR,FIXED ELECTROLYTIC	220UF YK 16V 20% FM5 TP 5	RUBYCON,SAMMHA	CE5(85)
49	0CE227X4638	CAPACITOR,FIXED ELECTROLYTIC	220UF RD 25V 20% FM5 TP 5	RUBYCON,SAMMHA	CE9,10(105)
50	0CE105ZK638	CAPACITOR,FIXED ELECTROLYTIC	1UF YK 50V 20% FM5 TP 5	RUBYCON,SAMMHA	CE13(85)
51	0CE107Z4638	CAPACITOR,FIXED ELECTROLYTIC	100UF YK 25V 20% FM5 TP 5	RUBYCON,SAMMHA	CE15(85)
52	0CE106ZK638	CAPACITOR,FIXED ELECTROLYTIC	10UF YK 50V 20% FM5 TP 5	RUBYCON,SAMMHA	CE6-8,11,12,14(85)
53	0CE4766H638	CAPACITOR,FIXED ELECTROLYTIC	47UF SMS,S6 25V 20% FM5 TP 5	RUBYCON,SAMMHA	CE16(85)
54	0CE106ZK638	CAPACITOR,FIXED ELECTROLYTIC	10UF YK 50V 20% FM5 TP 5	RUBYCON,SAMMHA	CE18(85) (WT-SNR)
55	0CK471DK96A	CAPACITOR,FIXED CERAMIC(HIGH DIELECTRIC)	0.00047UF 2012 50V 80%,-20% R/TP X7R	MURATA	CC1
56	0CK2210Z510	CAPACITOR,FIXED CERAMIC(HIGH DIELECTRIC)	220P 2KV K B 5	SAW MHA, DOOSAN	CC2
57	0CK224DK94A	CAPACITOR,FIXED CERAMIC(HIGH DIELECTRIC)	220NF 2012 50V 80%,-20% F1Y5V1 R/TP	MURATA	CC3
58	0CK104DK94A	CAPACITOR,FIXED CERAMIC(HIGH DIELECTRIC)	100NF 2012 50V 80%,-20% R/TP F1Y5V1	MURATA	CC4-6,8,9,30
59	0CK2230K96A	CAPACITOR,FIXED CERAMIC(HIGH DIELECTRIC)	22NF 2012 50V 80%,-20% R/TP X7R	MURATA	CC7,10,12-16,18,20-28
60	0CK2230K96A	CAPACITOR,FIXED CERAMIC(HIGH DIELECTRIC)	22NF 2012 50V 80%,-20% R/TP X7R	MURATA	CC32 (WT-SNR)
61	0CK102DK96A	CAPACITOR,FIXED CERAMIC(HIGH DIELECTRIC)	1NF 2012 50V 80%,-20% R/TP X7R	MURATA	CC17,19,31
62	0CK2230K949	CAPACITOR,FIXED CERAMIC(HIGH DIELECTRIC)	22NF 50V Z F 1A52	TAE YANG	CC29
63	0C022418670	CAPACITOR,FIXED FILM	0.22UF D 275V 20% M/PP NI R	PILKOR	CM2

EXPLANATION FOR MICOM CIRCUIT

No	P/NO	DESCRIPTION	SPEC	MAKER	REMARK
64	OCF33408670	CAPACITOR, FIXED FILM	330NF 0.275V 20% BULK M/PP NI	PILKOR	CM1
65	OC04732Y430	CAPACITOR, FIXED FILM	47000PF S 630V J M/PE NI R	SEIL	CM3
66	OC02231N409	CAPACITOR, FIXED FILM	0.022UF D 100V J PE TP	SAMHWA	CM4
67	ORW3303J609	RESISTOR, FIXED POWER COATED WIRE-WOUND	330K OHM 1 W 5% TA52	SMART, CHOHYANG	R1
68	OR05603H609	RESISTOR, FIXED CARBON FILM	560K OHM 1/2 W 5% TA52	SMART, CHOHYANG	R2
69	ORS5602K641	RESISTOR, FIXED METAL OXIDE FILM	56K OHM 2 W 5.00% F20	SMART, CHOHYANG	R3
70	OR06801G609	RESISTOR, FIXED CARBON FILM	6.8K OHM 1/4 W 5.00% TA52	SMART, CHOHYANG	R4
71	OR00822G609	RESISTOR, FIXED CARBON FILM	82 OHM 1/4 W 5.00% TA52	SMART, CHOHYANG	R5
72	OR01000G609	RESISTOR, FIXED CARBON FILM	100 OHM 1/4 W 5.00% TA52	SMART, CHOHYANG	R5
73	OR06800G609	RESISTOR, FIXED CARBON FILM	680 OHM 1/4 W 5.00% TA52	SMART, CHOHYANG	R6
74	ORW0101J609	RESISTOR, FIXED POWER COATED WIRE-WOUND	1 OHM 1 W 5% TA52 (NON-INDUCTIVE)	SMART, CHOHYANG	ROCP
75	ORW0560J609	RESISTOR, FIXED POWER COATED WIRE-WOUND	0.56 OHM 1 W 5% TA52 (NON-INDUCTIVE)	SMART, CHOHYANG	ROCP
76	OR01801G609	RESISTOR, FIXED CARBON FILM	1.8K OHM 1/4 W 5% TA52	SMART, CHOHYANG	R8
77	ORS5602K641	RESISTOR, FIXED METAL OXIDE FILM	56K OHM 2 W 5.00% F20	SMART, CHOHYANG	R10
78	OR00682H609	RESISTOR, FIXED CARBON FILM	68 OHM 1/2 W 5.00% TA52	SMART, CHOHYANG	R67
79	OR01000G609	RESISTOR, FIXED CARBON FILM	100 OHM 1/4 W 5% TA52	SMART, CHOHYANG	R11, 23
80	OR01002G609	RESISTOR, FIXED CARBON FILM	10K OHM 1/4 W 5% TA52	SMART, CHOHYANG	R39, 55, 56
81	OR04701G609	RESISTOR, FIXED CARBON FILM	4.7K OHM 1/4 W 5% TA52	SMART, CHOHYANG	R13, 15, 19, 20, 43, 50, 65, 66
82	OR03600H609	RESISTOR, FIXED CARBON FILM	360 OHM 1/2 W 5% TA52	SMART, CHOHYANG	R29, 30, 31
83	OR01001G609	RESISTOR, FIXED CARBON FILM	1K OHM 1/4 W 5% TA52	SMART, CHOHYANG	R26, 27
84	ORH2200L622	RESISTOR, METAL GLAZED(CHIP)	220 OHM 1/8 W 5% 2012 R/TP	RCHM	R77
85	ORH1001L622	RESISTOR, METAL GLAZED(CHIP)	1K OHM 1/8 W 5% 2012 R/TP	RCHM	R9
86	ORH1004L622	RESISTOR, METAL GLAZED(CHIP)	1M OHM 1/8 W 5% 2012 R/TP	RCHM	R14
87	ORH1002L622	RESISTOR, METAL GLAZED(CHIP)	10K OHM 1/8 W 5% 2012 R/TP	RCHM	R12, 16, 46, 57
88	ORH4701L622	RESISTOR, METAL GLAZED(CHIP)	4.7K OHM 1/8 W 5% 2012 R/TP	RCHM	R24, 25, 28, 37, 44, 61, 73-76, 78
89	ORH2001L622	RESISTOR, METAL GLAZED(CHIP)	2K OHM 1 / 8 W 5% 2012 R/TP	RCHM	R21, 22, 32-34, 52-54, 58, 63, 64
90	ORH3300L622	RESISTOR, METAL GLAZED(CHIP)	330 OHM 1/8 W 5% 2012 R/TP	RCHM	R47
91	ORH2001L622	RESISTOR, METAL GLAZED(CHIP)	2K OHM 1 / 8 W 5% 2012 R/TP	RCHM	R72 (WT-SNR)
92	ORJ0000E672	RESISTOR, METAL GLAZED(CHIP)	0 OHM 1/8 W 5% 2012 R/TP	RCHM	CC32 (WT-SNR)
93	ORR2612E472	RESISTOR, METAL GLAZED(CHIP)	26.1K OHM 1/8 W 1% 2012 R/TP	RCHM	RRI
94	ORH1002L422	RESISTOR, METAL GLAZED(CHIP)	10K OHM 1/8 W 1% 2012 R/TP	RCHM	RT1
95	OR01002G609	RESISTOR, FIXED CARBON FILM	10K OHM 1/4 W 5% TA52	SMART, CHOHYANG	RCR1
96	OR01202G609	RESISTOR, FIXED CARBON FILM	12K OHM 1/4 W 5% TA52	SMART, CHOHYANG	RCR1
97	OR08201G609	RESISTOR, FIXED CARBON FILM	8.2K OHM 1/4 W 5.00% TA52	SMART, CHOHYANG	RCR1
98	OR03901G609	RESISTOR, FIXED CARBON FILM	3.9K OHM 1/4 W 5% TA52	SMART, CHOHYANG	R38, 45
99	OR03300G609	RESISTOR, FIXED CARBON FILM	330 OHM 1/4 W 5.00% TA52	SMART, CHOHYANG	RA0
100	OR01501H609	RESISTOR, FIXED CARBON FILM	1.5K OHM 1/2 W 5% TA52	SMART, CHOHYANG	R41, 48
101	OR02001G609	RESISTOR, FIXED CARBON FILM	2K OHM 1/4 W 5% TA52	SMART, CHOHYANG	R35, 36, 42, 49, 51, 59, 60, 62
102	ORW1622G409	RESISTOR, FIXED METAL FILM	16.2K OHM 1/4 W 1.00% TA52	SMART, CHOHYANG	R1M1, R1
103	ORW2612G409	RESISTOR, FIXED METAL FILM	26.1K OHM 1/4 W 1.00% TA52	SMART, CHOHYANG	R1M1, R12
104	ORW101G409	RESISTOR, FIXED METAL FILM	9.1K OHM 1/4 W 1.00% TA52	SMART, CHOHYANG	RF2
105	ORW2401G409	RESISTOR, FIXED METAL FILM	2.4K OHM 1/4 W 1.00% TA52	SMART, CHOHYANG	RF3
106	ORW1002G409	RESISTOR, FIXED METAL FILM	10K OHM 1/4 W 1.00% TA52	SMART, CHOHYANG	RW1
107	OR01201G609	RESISTOR, FIXED CARBON FILM	1.2K OHM 1/4 W 5% TA52	SMART, CHOHYANG	(R) J1
108	OR01201G609	RESISTOR, FIXED CARBON FILM	1.2K OHM 1/4 W 5% TA52	SMART, CHOHYANG	(R) J2
109	OTRKE00008A	TRANSISTOR, BIPOLARS	KEC KTBI51 BK T0126 60V 5A	KEC	Q2, 4
110	OTR319809AA	TRANSISTOR	KTC3198-TP-Y IKTClB15KEC	KEC	Q3, 5
111	OTR106009AC	TRANSISTOR	KRA 106M(KRA2206) KEC TP T092M 50V 100MA	KEC	Q6
112	OTR106009AF	TRANSISTOR	KRC 106M KEC TP T092M 50V 100MA	KEC	Q7
113	6210JBB001A	FILTER(CIFRC), EMC	BF33510A0 SAMIHA 52 -	SAW WHA	FBI
114	6600RRT001W	SWITCH, TACT	THVV502GAA POSTECH 12V DC 50MA TAPING	POSTECH	SW1
115	6600JBB003B	SWITCH, DIP	KSD02H OTAX NONE NONE 2P DIP S/W	OTAX	SW2
116	6854B50001A	JUMP WIRE	0.6MM 175,100,125,150MM TP TAPING SN	DAE A LEAD	J01-14, 16-29, 31-34, 39, 41
117	6854B50001A	JUMP WIRE	0.6MM 175,100,125,150MM TP TAPING SN	DAE A LEAD	J1
118	6854B50001A	JUMP WIRE	0.6MM 175,100,125,150MM TP TAPING SN	DAE A LEAD	J2
119	6854B50001A	JUMP WIRE	0.6MM 175,100,125,150MM TP TAPING SN	DAE A LEAD	(R) J1
120	6854B50001A	JUMP WIRE	0.6MM 175,100,125,150MM TP TAPING SN	DAE A LEAD	(R) J2
121	6854B50001A	JUMP WIRE	0.6MM 175,100,125,150MM TP TAPING SN	DAE A LEAD	JF1, J2
122	6908JBJ002A	BUZZER	EM-20K BLUEJON PIEZO 2KHZ 80DB	BLUEJON	BUZZER
123	6200JBB001B	FILTER(CIFRC), EMC	I20+0.1UF PILKOR - -	PILKOR	CR1
124	6200JBB009B	FILTER(CIFRC), EMC	CH40050 TNC BK - -	TNC	L1
125	6200JBB007X	FILTER(CIFRC), EMC	UV11-05320 TNC BK 0.5A 320MH	TNC	L2
126	OLR1001M4FO	INDUCTOR, RADIAL LEAD	1000UH 20% R 6X12.5 BULK	TNC	L3, 4
127	3J02447C	FUSE, DRAWING	15A 250V - EF	SAM JU	FUSE1
128	6901JBB001A	FUSE ASSEMBLY	KORE-PJT N/S	SAM JU	FUSE HOLDER
129	OF55001B502	FUSE, SLOW BLOW	5000MA 250 V 5.2X20 LD/GL UL / CSA	SAM JU	FUSE2
130	0001030F	CONNECTOR (CIFRC), WAFER	GP88191-2 HAN KUK DAN JA NA NA NA	KET	TAB1, 2
131	4920JBJ007A	HEAT SINK	23.3x17x25 DRIVE IC STR R-S64, 65, 73 2PIN 1-SCREW 3MM	TAE SUNG	(IC) 2
132	15BF030241B	SCREW TAP TITE(S), BINDING HEAD	+ D3.0 L8.0 M5WR3/FZY	-	(IC) 2
133	9VWF0120000	SOLDER(ROSIN WIRE) R50	DI, 20	-	-
134	49111004	SOLDER, SOLDERING	NA HEESUNG METAL BAR SN 63% NA	HEE SUNG	-
135	59333105	FLUX	SG:0.825-0.830 KOREA F.H-206	KCKI	-

EXPLANATION FOR MICOM CIRCUIT

(2) GR-L267BNRY (Refer to appendix)

No	P/NO	DESCRIPTION	SPEC	MAKER	REMARK
1	670.880.98	RESISTOR	L/2674R 0V0-0.1U UL NON-W/ROOM VER-2	UDC SAN	T1,1,6(NON-MAGIC ROOM)
2	670.820.30	TRANSFORMER,SMP3 COIL	02/0H-FJT DELUXE WESJ	SAM LI	TRANS
3	6630M02707	CONNECTOR (ICRCL) WAFER	YR365 YEONHO 7P 3.95MM (7P-2,4,6)	YEON HO	CON2
4	6630M00509	CONNECTOR (ICRCL) WAFER	YR365 YEONHO 5P 3.95MM YR365-05AV RED	YEON HO	CON4
5	6630M02509	CONNECTOR (ICRCL) WAFER	YR365 YEONHO 5P 3.95MM (5P-2,4,6,B)	YEON HO	CON1
6	6630M01111	CONNECTOR (ICRCL) WAFER	YR365 YEONHO 11P 3.95MM YR365-11AV (11P-2,4,6,B,I,O)	YEON HO	CON3
7	6630.88007K	CONNECTOR (ICRCL) WAFER	91789-1 AMP 11P 2.5MM STRAIGHT SN	AMP	CON5
8	6630.88007J	CONNECTOR (ICRCL) WAFER	91789-1 AMP 10P 2.5MM STRAIGHT SN	AMP	CON8
9	6630.88007L	CONNECTOR (ICRCL) WAFER	91789-1 AMP 12P 2.5MM STRAIGHT SN	AMP	CON6
10	6630.88007A	CONNECTOR (ICRCL) WAFER	91789-1 AMP 13P 2.5MM STRAIGHT SN	AMP	CON7
11	6630.88007E	CONNECTOR (ICRCL) WAFER	91784-1 AMP 6P 2.5MM STRAIGHT SN	AMP	CON9
12	0177.82005N	IC, DRAWING	1M874MAIN 64P SDIP ST DIP GR-00 TOW-FJT UL	TOSHIBA	IC1
13	0177.82005N	IC, DRAWING	1M874MAIN 64P SDIP ST DIP GR-00 YINKE-FJT BETTER INDIA	TOSHIBA	IC1
14	01FM69001A	IC, POWER MANAGEMENT	STR-062EL SANKEN 8PIN 10220 ST SMP3 T-CHIP	SANKEN	IC2
15	01FM69001A	IC, POWER MANAGEMENT	PS2661-1 NEC 4P, DIP BK : TL762.F	NEC	IC3,B
16	01KE43000A	IC, KECC	KIA431 3 PIN TP - -	KECC	IC4
17	01KE43000A	IC, KECC	KIA7825P	KECC	IC5
18	01KE43000C	IC, KECC	KID55003AF 1650P BK 7CH DRIVER	KECC	IC6,7
19	01KE70420A	IC, KECC	KIA7042P KECC 3P BK RESET	KECC	IC9
20	01D177400A	IC, DRAWING	1A7774AP 16, SDIP BK DRIVE, IC STEPPING MOTOR	TOSHIBA	IC10
21	01R492200A	IC, CHIP	BA3222 165P BK REGULABLE MOTOR DRIVER	ROHM	IC11
22	01R492400D	IC, CHIP	BR93 CA65P 8 PIN SMD BK FERROH	ROHM	IC12
23	0215TL0001A	IC, STANDARD LOGIC	NE4558FP MITSUBISHI 20 R/TIP CONVERT	MITSUBISHI	IC13
24	01KE650030C	IC, KECC	KID65003AF 1650P BK 7CH DRIVER	KECC	IC14
25	6520.82004D	RELAY	AL6282 MATSUSHITA 250VAC 16A 12VDC IA NO VENTING	MATSUSHITA	RY1,4,6
26	6520.82004E	RELAY	OHU II DEC 250VAC 16A 12VDC IA NO VENTING	JAIL	RY2
27	6520.82004F	RELAY	ALD12 MATSUSHITA 250VAC 3A 12VDC IA NO VENTING	MATSUSHITA	RY3,7,8,9,11
28	6520.82004G	RELAY	65N-1A1 JAPAN 250VAC 5A 12VDC IA NO VENTING	OMRON	RY10,PILOT1
29	6520.82004H	RELAY	65N-1A1 JAPAN 250VAC 5A 12VDC IA NO VENTING	OMRON	RY14(DISP) LAMP/F LAMP1
30	6520.82004I	RELAY	65N-1A1 JAPAN 250VAC 5A 12VDC IA NO VENTING	OMRON	
31	6520.82004J	RELAY	65N-1A1 JAPAN 250VAC 5A 12VDC IA NO VENTING	OMRON	
32	6520.82004K	RELAY	65N-1A1 JAPAN 250VAC 5A 12VDC IA NO VENTING	OMRON	
33	6520.82004L	RELAY	65N-1A1 JAPAN 250VAC 5A 12VDC IA NO VENTING	OMRON	
34	6520.82004M	RELAY	65N-1A1 JAPAN 250VAC 5A 12VDC IA NO VENTING	OMRON	
35	6520.82004N	RELAY	65N-1A1 JAPAN 250VAC 5A 12VDC IA NO VENTING	OMRON	
36	6520.82004O	RELAY	65N-1A1 JAPAN 250VAC 5A 12VDC IA NO VENTING	OMRON	
37	6520.82004P	RELAY	65N-1A1 JAPAN 250VAC 5A 12VDC IA NO VENTING	OMRON	
38	6520.82004Q	RELAY	65N-1A1 JAPAN 250VAC 5A 12VDC IA NO VENTING	OMRON	
39	6520.82004R	RELAY	65N-1A1 JAPAN 250VAC 5A 12VDC IA NO VENTING	OMRON	
40	6520.82004S	RELAY	65N-1A1 JAPAN 250VAC 5A 12VDC IA NO VENTING	OMRON	
41	6520.82004T	RELAY	65N-1A1 JAPAN 250VAC 5A 12VDC IA NO VENTING	OMRON	
42	000448098B	DIODE, SWITCHING	1N4148 1P ROHM 0035 75V 450ML	ROHM (PHN)HANG	D1
43	002476260D	CAPACITOR, FIXED ELECTROLYTIC	47UF 16V 450V 20% BULK SMD IN (KLTAR/CAM)	SAMHWA/SAM YOUNG/ALBIONCVG-LUXON	CE1(105)
44	002476260E	CAPACITOR, FIXED ELECTROLYTIC	68UF 16V 450V 20% BULK SMD IN (KLTAR/CAM)	SAMHWA/SAM YOUNG/ALBIONCVG-LUXON	CE1(105)
45	002226K633	CAPACITOR, FIXED ELECTROLYTIC	22UF 16V 50V 20% FMS TP 51YXA/SMI	SAM YOUNG/SAMHWA/ALBIONCVG-LUXON	CE2(105)
46	002089H430	CAPACITOR, FIXED ELECTROLYTIC	1000UF 16V 50V 20% FL BULK (KX/YXG/LU)	SAMHWA/SAM YOUNG/ALBIONCVG-LUXON	CE3(105)
47	002089H430	CAPACITOR, FIXED ELECTROLYTIC	1000UF 16V 50V 20% FL BULK (KX/YXG/LU)	SAMHWA/SAM YOUNG/ALBIONCVG-LUXON	CE3(105)
48	002227F633	CAPACITOR, FIXED ELECTROLYTIC	22UF 16V 50V 20% FMS TP 51YXA/SMI	SAM YOUNG/SAMHWA/ALBIONCVG-LUXON	CE4(105)
49	002227F633	CAPACITOR, FIXED ELECTROLYTIC	22UF 16V 50V 20% FMS TP 51YXA/SMI	SAM YOUNG/SAMHWA/ALBIONCVG-LUXON	CE4(105)
50	002227F633	CAPACITOR, FIXED ELECTROLYTIC	22UF 16V 50V 20% FMS TP 51YXA/SMI	SAM YOUNG/SAMHWA/ALBIONCVG-LUXON	CE4(105)
51	002089H430	CAPACITOR, FIXED ELECTROLYTIC	100UF 16V 50V 20% FMS TP 51YXA/SMI	SAM YOUNG/SAMHWA/ALBIONCVG-LUXON	CE5(105)
52	002089H430	CAPACITOR, FIXED ELECTROLYTIC	100UF 16V 50V 20% FMS TP 51YXA/SMI	SAM YOUNG/SAMHWA/ALBIONCVG-LUXON	CE5(105)
53	002089H430	CAPACITOR, FIXED ELECTROLYTIC	100UF 16V 50V 20% FMS TP 51YXA/SMI	SAM YOUNG/SAMHWA/ALBIONCVG-LUXON	CE5(105)
54	002089H430	CAPACITOR, FIXED ELECTROLYTIC	100UF 16V 50V 20% FMS TP 51YXA/SMI	SAM YOUNG/SAMHWA/ALBIONCVG-LUXON	CE5(105)
55	002220K210	CAPACITOR, FIXED CERAMIC(HIGH DIELECTRIC)	0.00047F 20V 50V 20% R7P X7R	SAMHWA/SAM YOUNG/ALBIONCVG-LUXON	CE1(B5) (INT-SNR)
56	002220K210	CAPACITOR, FIXED CERAMIC(HIGH DIELECTRIC)	220P 20V K B 5	SAM WHA, HONGMING	CC2
57	002220K210	CAPACITOR, FIXED CERAMIC(HIGH DIELECTRIC)	220F 20V 50V 80% 20% F1Y5V1 R7P	MURATA	CC3
58	002220K210	CAPACITOR, FIXED CERAMIC(HIGH DIELECTRIC)	100NF 20V 50V 80% 20% R7P F1Y5V1	MURATA	CC4 5,6,8,9,30
59	002220K210	CAPACITOR, FIXED CERAMIC(HIGH DIELECTRIC)	22NF 20V 50V 80% 20% R7P X7R	MURATA	CC1,10,12,15,16,20,28
60	002220K210	CAPACITOR, FIXED CERAMIC(HIGH DIELECTRIC)	22NF 20V 50V 80% 20% R7P X7R	MURATA	CC10
61	002220K210	CAPACITOR, FIXED CERAMIC(HIGH DIELECTRIC)	1NF 20V 50V 80% 20% R7P X7R	MURATA	CC2 (INT-SNR)
62	002220K210	CAPACITOR, FIXED CERAMIC(HIGH DIELECTRIC)	1NF 20V 50V 80% 20% R7P X7R	MURATA	CC9,31
63	002220K210	CAPACITOR, FIXED CERAMIC(HIGH DIELECTRIC)	22NF 50V Z F T482	TAE YANG	CC29
64	002220K210	CAPACITOR, FIXED CERAMIC(HIGH DIELECTRIC)	0.22UF 0.275V 20% WMPF NI R	PILKOR	CM2
65	002340870	CAPACITOR, FIXED FILM	330NF 0.275V 20% BULK WMPF NI R	PILKOR	CM1
66	002340870	CAPACITOR, FIXED FILM	4700PF 5.00V 10% JFC NI R	ROHM	CC1
67	002340870	CAPACITOR, FIXED FILM	0.022UF 0.100V J PE TP	SAMHWA	CM4
68	002340870	RESISTOR, FIXED POWER COATED WIRE-WOUND	330K OHM 1/2 W 5% T482	SMART, CHOHYANG	R1
69	002340870	RESISTOR, FIXED CARBON FILM	330K OHM 1/2 W 5% T482	SMART, CHOHYANG	R2
70	002340870	RESISTOR, FIXED METAL OXIDE FILM	33K OHM 2 W 5.00% T482	SMART, CHOHYANG	R3
71	002340870	RESISTOR, FIXED CARBON FILM	6.8K OHM 1/4 W 5.00% T482	SMART, CHOHYANG	R4
72	002340870	RESISTOR, FIXED CARBON FILM	82 OHM 1/4 W 5.00% T482	SMART, CHOHYANG	R5
73	002340870	RESISTOR, FIXED CARBON FILM	100 OHM 1/4 W 5.00% T482	SMART, CHOHYANG	R6
74	002340870	RESISTOR, FIXED CARBON FILM	560 OHM 1/4 W 5.00% T482	SMART, CHOHYANG	R7
75	002340870	RESISTOR, FIXED POWER COATED WIRE-WOUND	1 OHM 1 W 5% T482 (NON-INDUCTIVE)	SMART, CHOHYANG	ROOP
76	002340870	RESISTOR, FIXED POWER COATED WIRE-WOUND	0.56 OHM 1 W 5% T482 (NON-INDUCTIVE)	SMART, CHOHYANG	ROOP
77	002340870	RESISTOR, FIXED CARBON FILM	1.8K OHM 1/4 W 5.00% T482	SMART, CHOHYANG	R8
78	002340870	RESISTOR, FIXED METAL OXIDE FILM	56K OHM 2 W 5.00% T482	SMART, CHOHYANG	R9
79	002340870	RESISTOR, FIXED CARBON FILM	56K OHM 1/2 W 5.00% T482	SMART, CHOHYANG	R67
80	002340870	RESISTOR, FIXED CARBON FILM	100 OHM 1/4 W 5% T482	SMART, CHOHYANG	R11,23
81	002340870	RESISTOR, FIXED CARBON FILM	10K OHM 1/4 W 5% T482	SMART, CHOHYANG	RES,56
82	002340870	RESISTOR, FIXED CARBON FILM	10K OHM 1/4 W 5% T482	SMART, CHOHYANG	R39
83	002340870	RESISTOR, FIXED CARBON FILM	4.7K OHM 1/4 W 5% T482	SMART, CHOHYANG	R13,15,19,20,43,50,55,56
84	002340870	RESISTOR, FIXED CARBON FILM	360 OHM 1/2 W 5% T482	SMART, CHOHYANG	R29,30,31
85	002340870	RESISTOR, FIXED CARBON FILM	1K OHM 1/4 W 5% T482	SMART, CHOHYANG	R26,27
86	002340870	RESISTOR, METAL GLAZED(DIP)	220 OHM 1/8 W 5% 2012 R7P	ROHM	R77
87	002340870	RESISTOR, METAL GLAZED(DIP)	1K OHM 1/8 W 5% 2012 R7P	ROHM	R78
88	002340870	RESISTOR, METAL GLAZED(DIP)	10K OHM 1/8 W 5% 2012 R7P	ROHM	R79
89	002340870	RESISTOR, METAL GLAZED(DIP)	4.7K OHM 1/8 W 5% 2012 R7P	ROHM	R12,16,46,57
90	002340870	RESISTOR, METAL GLAZED(DIP)	2K OHM 1/8 W 5% 2012 R7P	ROHM	R24,25,26,31,44,61,73,75,78
91	002340870	RESISTOR, METAL GLAZED(DIP)	2K OHM 1/8 W 5% 2012 R7P	ROHM	R21,22,32,34,52,54,55,63,64
92	002340870	RESISTOR, METAL GLAZED(DIP)	330 OHM 1/8 W 5% 2012 R7P	ROHM	R47
93	002340870	RESISTOR, METAL GLAZED(DIP)	2K OHM 1/8 W 5% 2012 R7P	ROHM	R72 (INT-SNR)
94	002340870	RESISTOR, METAL GLAZED(DIP)	0 OHM 1/8 W 5% 2012 R7P	ROHM	CE2(INT-SNR)
95	002340870	RESISTOR, METAL GLAZED(DIP)	10K OHM 1/8 W 5% 2012 R7P	ROHM	R11
96	002340870	RESISTOR, FIXED CARBON FILM	10K OHM 1/4 W 5% T482	SMART, CHOHYANG	RCR1
97	002340870	RESISTOR, FIXED CARBON FILM	10K OHM 1/4 W 5% T482	SMART, CHOHYANG	RCR2
98	002340870	RESISTOR, FIXED CARBON FILM	3.3K OHM 1/4 W 5.00% T482	SMART, CHOHYANG	RCR3
99	002340870	RESISTOR, FIXED CARBON FILM	3.3K OHM 1/4 W 5% T482	SMART, CHOHYANG	RCR4
100	002340870	RESISTOR, FIXED CARBON FILM	330 OHM 1/4 W 5.00% T482	SMART, CHOHYANG	RCR5
101	002340870	RESISTOR, FIXED CARBON FILM	1.5K OHM 1/2 W 5% T482	SMART, CHOHYANG	RCR6
102	002340870	RESISTOR, FIXED CARBON FILM	2K OHM 1/4 W 5% T482	SMART, CHOHYANG	RCR7,36,49,51,59,60,62
103	002340870	RESISTOR, FIXED CARBON FILM	2K OHM 1/4 W 5% T482	SMART, CHOHYANG	RCR8
104	002340870	LAMP, WIRE	0 OHM 1.25, 0.05, 0.50MM TP TAPING SN	SMART, CHOHYANG	R42
105	002340870	RESISTOR, FIXED METAL FILM	16.2K OHM 1/4 W 1.00% T482	SMART, CHOHYANG	R14, R15
106	002340870	RESISTOR, FIXED METAL FILM	26.1K OHM 1/4 W 1.00% T482	SMART, CHOHYANG	R11, R12
107	002340870	RESISTOR, FIXED METAL FILM	9.1K OHM 1/4 W 1.00% T482	SMART, CHOHYANG	R17, R18
108	002340870	RESISTOR, FIXED METAL FILM	2.2K OHM 1/4 W 1.00% T482	SMART, CHOHYANG	R19
109	002340870	RESISTOR, FIXED METAL FILM	26.1K OHM 1/4 W 1.00% T482	SMART, CHOHYANG	R1
110	002340870	RESISTOR, FIXED METAL FILM	1.2K OHM 1/4 W 5% T482	SMART, CHOHYANG	IR1,11
111	002340870	RESISTOR, FIXED CARBON FILM	1.5K OHM 1/4 W 5% T482	SMART, CHOHYANG	IR1,12
112	01R62000A	TRANSISTOR,BIPOLARS	2SC1082 BK 100G 50V 5A	KEC	Q1
113	01R62000A	TRANSISTOR,BIPOLARS	KEC 1082BK 100G 50V 5A	KEC	Q2
114	01R39803A	TRANSISTOR	KT398B TP-Y 1KTCIBP1KCC	KEC	Q3
115	01R39803A	TRANSISTOR	KTA 1084(KR2206) KEC TP 103SM 50V 100MA	KEC	Q4
116	01R62000A	TRANSISTOR	KEC 1082 BK 100G 50V 5A	KEC	Q5
117	6210.88001A	FILTER(CIRCUIT), EMC	9F3F3040 SAMHWA 52 -	SAM WHA	FB1

EXPLANATION FOR MICOM CIRCUIT

No	P/NO	DESCRIPTION	SPEC	MAKER	REMARK
114	6600RRT001W	SWITCH, TACT	THW502GAA POSTECH (2V, DC, 50MA TAPING	POSTECH	SW1
115	6600LB0003B	SWITCH, DIP	K5002H OTAX NONE NONE 2P DIP 5/W	OTAX	SW2
116	6654E50001A	JUMP WIRE	0.6MM (75,100,125,150MM) TP TAPING SN	DAE A LEAD	J01-14,16-22,31-34,39,41
117	6654E50001A	JUMP WIRE	0.6MM (75,100,125,150MM) TP TAPING SN	DAE A LEAD	J1
118	6654E50001A	JUMP WIRE	0.6MM (75,100,125,150MM) TP TAPING SN	DAE A LEAD	J2
119	6654E50001A	JUMP WIRE	0.6MM (75,100,125,150MM) TP TAPING SN	DAE A LEAD	TR1 J1
120	6654E50001A	JUMP WIRE	0.6MM (75,100,125,150MM) TP TAPING SN	DAE A LEAD	TR1 J2
121	6654E50001A	JUMP WIRE	0.6MM (75,100,125,150MM) TP TAPING SN	DAE A LEAD	JF1, F2
122	6906LB0002A	BUZZER	BM-20K BLUEON PIEZO 2KHZ 80DB	BLUEON	BUZZER
123	6200LB0001B	FILTER(CIRCT), EMC	120*0.1UF PILKOR - -	PILKOR	CR1
124	6200LB0005B	FILTER(CIRCT), EMC	CH40050 TNC BK - -	TNC	L1
125	6200LB0007X	FILTER(CIRCT), EMC	LV111-05320 TNC BK 0.5A 320MH	TNC	L2
126	0LR000M4F0	INDUCTOR, RADIAL LEAD	1000UH 20% R 6X12.5 BULK	TNC	L4
126	0LR000M4F0	INDUCTOR, RADIAL LEAD	1000UH 20% R 6X12.5 BULK	TNC	L3
127	3J02447C	FUSE, DRAWING	15A 250V - EF	SAW JU	FUSE1
128	6901LB0001A	FUSE, ASSEMBLY	ROBE P.O. 1V'S	SAW JU	FUSE HOLDER
129	0F5500R502	FUSE, SLOW BLOW	5000MA 250 V 5.2X20 LD/GL UL / CSA	SAW JU	FUSE2
130	00001030F	CONNECTOR (CIRCT), WAFER	GPBB191-2 HAN KUK DAN JA NA NA NA	NET	TAB1,2
131	4920LB0007A	HEAT SINK	23_3417*25 DRIVE IC STR R-564,65,73 2PIN 1-SCREW 3MM	TAE SUNG	IC21
132	29F030241B	SCREEN TAP (TITE)S1, BANDING HEAD	+ D3.0 L3.0 MSRP3/727	-	IC21
133	55000000BA	SOLDER(ROSN WIRE) R50	SR-34 PB FREE - LFM-48	-	-
134	55W2U1L05AA	SOLDER, SOLDERING	LFM-38, SN 3.0AG-0.80UX 3.0MM	-	HEE SUNG
135	72452B0004A	FLUX	SV-PBF-06 KSK 12.5 WT% 0.815+-0.003	KOKI	-

EXPLANATION FOR MICOM CIRCUIT

(3) GR-L267BV(T)RA (Refer to appendix)

No	P/NO	DESCRIPTION	SPEC	MAKER	REMARK
1	6870JB8096A	PWB(PCB)	CD2-PJT DELUXE VER-1 NAESU	DOO SAN	T=1.6(MAGIC ROOM)
2	6170JB2013C	TRANSFORMER,SMPSC01LJ	CD2/CH-PJT DELUXE NAESU	SAM IL	TRANS
3	6630VM02707	CONNECTOR (CIRC),WAFER	YW396 YEDNHD 7P 3.96MM (7P-2,4,6)	YEDN HD	CDN2
4	6630VM00509	CONNECTOR (CIRC),WAFER	YW396 YEDNHD 9P 3.96MM YW396-09AV RED	YEDN HD	CDN4
5	6630VM02609	CONNECTOR (CIRC),WAFER	YW396 YEDNHD 9P 3.96MM (9P-2,4,6,8)	YEDN HD	CDN1
6	6630VM01111	CONNECTOR (CIRC),WAFER	YW396 YEDNHD 11P 3.96MM YW396-11AV (11P-2,4,6,8,10)	YEDN HD	CDN3
7	6630JB8007G	CONNECTOR (CIRC),WAFER	917786-1 AMP 8P 2.5MM STRAIGHT SN	AMP	CDN5
8	6630JB8007J	CONNECTOR (CIRC),WAFER	917788-1 AMP 10P 2.5MM STRAIGHT SN	AMP	CDN8
9	6630JB8007L	CONNECTOR (CIRC),WAFER	917790-1 AMP 12P 2.5MM STRAIGHT SN	AMP	CDN6
10	6630JB8010A	CONNECTOR (CIRC),WAFER	917791-1 AMP 13P 2.5MM STRAIGHT SN	AMP	CDN7
11	01ZZJB2030A	IC,DRAWING	TMP87C841N 64 SDIP ST CD2-PJT NAESU MASK	TOSHIBA	IC1(=01ZZJB2030B)
12	01PMGSK001A	IC,POWER MANAGEMENT	STR-G6351L SANKEN 5PIN TD220 ST SMPS 1 CHIP	SANKEN	IC2
13	01PMGNE001A	IC,POWER MANAGEMENT	PS2561-1 NEC 4P,DIP BK = TLP762JF	NEC	IC3,8
14	01KE431000A	IC,KEC	KIA431 3 PIN TP --	KEC	IC4
15	01KE780500W	IC,LINEAR	KIA7805PI - - - -	KEC	IC5
16	01KE650030C	IC,KEC	KID65003AF 16SDP BK 7CH DRIVER	KEC	IC6,7
17	01KE704200A	IC,KEC	KIA7042P KEC 3P BK RESET	KEC	IC9
18	01T0777400A	IC,DRAWING	TA7774AP 16,SDIP BK DRIVE,IC STEPPING MOTOR	TOSHIBA	IC10
19	01RH622200A	IC,RDHM	BA6222 10SIP BK REVERSIBLE MOTOR DRIVER	RDHM	IC11
20	6920000001A	RELAY	AL15B12 MATSUSHITA 250VAC 16A 12VDC 1A NO VENTING	MATSUSHITA	RY1,4,6
21	6920JB2004D	RELAY	DH12D1-D-Q (JAPAN) DEC 250VAC 10A 12VDC 1A NO VENTING	DAIICHI	RY2
22	6920JB2003B	RELAY	ALD112 MATSUSHITA 250VAC 3A 12VDC 1A	MATSUSHITA	RY3,7,8,9,11
23	6920JB2003B	RELAY	ALD112 MATSUSHITA 250VAC 3A 12VDC 1A	MATSUSHITA	RY10(PILOT)
24	6920ALZ001A	RELAY	ALZ12B12 NAIS 250VAC 16A 12VDC 1C NO VENTING	NAIS	RY5
25	6920JB2009A	RELAY	G5S-1 DMRDN 12V 3A 227V 1C	DMRDN	RY12(H/BAR)
26	6920JB2009A	RELAY	G5S-1 DMRDN 12V 3A 227V 1C	DMRDN	RY13
27	6212JB8001B	RESONATOR,CERAMIC	CST50400MG03 MURATA 4MHZ . TP -	MURATA	OSC1
28	6102JB8001A	VARIATOR	SVC621D-14A SAMWHA UL/VDE BK 620V	SAW WHA,IL JIN	VA1
29	0DR107009AA	DIODE,RECTIFIERS	FR107 TP DELTA DD41 1000V 1A 3	DELTA	D1,2,12,13,14,15
30	0DRSA00090A	DIODE,RECTIFIERS	RL3 SANKEN BK NDN 350V 3.5A 80A 50NSEC 0.1MA	SANKEN	D3
31	0DRSA00090A	DIODE,RECTIFIERS	RL3 SANKEN BK NDN 350V 3.5A 80A 50NSEC 0.1MA	SANKEN	D4
32	0DB360000AA	DIODE,RECTIFIERS	D3SBA60 BK SHINDENGEN 600V 4A	SHINDENGEN	BD1
33	0DD400409AA	DIODE,RECTIFIERS	1N4004 PYUNG CHANG TP26 DD41 400V 1A 30A 75NS 5UA	DELTA,PYUNGCHANG	D5-9
34	0DD400709AA	DIODE,RECTIFIERS	1N4007 MOTOROLA TP DD41 600V 1.5A 60A 75NS 10UA	DELTA,PYUNGCHANG	D10
35	0DZR000188A	DIODE,ZENERS	RLZ RDHM R/TP LLD(LL-34) 500MW 5.6V 20MA .PF	RDHM	ZD1
36	0DD414809BB	DIODE,SWITCHING	1N4148 TP RDHM DD35 75V 450MIL	RDHM,PYUNGCHANG	D11
37	0CE476ZV6E0	CAPACITOR,FIXED ELECTROLYTIC	47UF HE 450V 20% BULK SNAP IN	RUBYCON	CE1(105)
38	0CE226ZK638	CAPACITOR,FIXED ELECTROLYTIC	22UF YXA 50V 20% FMS TP 5	RUBYCON	CE2(105)
39	0CE108ZH610	CAPACITOR,FIXED ELECTROLYTIC	1000UF YXG 25V 20% FL BULK	RUBYCON	CE3(105)
40	0CE108ZJ610	CAPACITOR,FIXED ELECTROLYTIC	1000UF YXG 35V 20% FL BULK	RUBYCON	CE4(105)
41	0CE227ZF638	CAPACITOR,FIXED ELECTROLYTIC	220UF YK 16V 20% FMS TP 5	RUBYCON	CE5(85)
42	0CE227XH638	CAPACITOR,FIXED ELECTROLYTIC	220UF RD 25V 20% FMS TP 5	SAW WHA	CE9,10(105)
43	0CE105ZK638	CAPACITOR,FIXED ELECTROLYTIC	1UF YK 50V 20% FMS TP 5	RUBYCON	CE13(85)
44	0CE107ZH638	CAPACITOR,FIXED ELECTROLYTIC	100UF YK 25V 20% FMS TP 5	RUBYCON	CE15(85)
45	0CE106ZK638	CAPACITOR,FIXED ELECTROLYTIC	10UF YK 50V 20% FMS TP 5	RUBYCON	CE6-8,11,12,14(85)
46	0CK471DK96A	CAPACITOR,FIXED CERAMIC(HIGH DIELECTRIC)	0.0047UF 2012 50V 80%,-20% R/TP X7R	MURATA	CC1
47	0CK22102510	CAPACITOR,FIXED CERAMIC(HIGH DIELECTRIC)	220P 2KV K B S	SAW WHA, DOOSAN	CC2
48	0CK224DK94A	CAPACITOR,FIXED CERAMIC(HIGH DIELECTRIC)	220NF 2012 50V 80%,-20% F(Y5V) R/TP	MURATA	CC3
49	0CK104DK94A	CAPACITOR,FIXED CERAMIC(HIGH DIELECTRIC)	100NF 2012 50V 80%,-20% R/TP F(Y5V)	MURATA	CC4~6,8,9,11
50	0CK223DK96A	CAPACITOR,FIXED CERAMIC(HIGH DIELECTRIC)	22NF 2012 50V 80%,-20% R/TP X7R	MURATA	CC7,10,12~16,18,20~28
51	0CK2230K949	CAPACITOR,FIXED CERAMIC(HIGH DIELECTRIC)	22NF 50V Z F TA52	TAE YANG	CC29
52	0CK102DK96A	CAPACITOR,FIXED CERAMIC(HIGH DIELECTRIC)	1NF 2012 50V 80%,-20% R/TP X7R	MURATA	CC17,19
53	0CQ22418670	CAPACITOR,FIXED FILM	0.22UF D 275V 20% M/PP NI R	PILKOR	CM2
54	0CF33408670	CAPACITOR,FIXED FILM	330NF 0 275V 20% BULK M/PP NI	PILKOR	CM1
55	0CQ4732Y430	CAPACITOR,FIXED FILM	47000PF S 630V J M/PE NI R	SEIL	CM3
56	0CQ2231N409	CAPACITOR,FIXED FILM	0.022 UF D 100V J PE TP	SAW WHA	CM4
57	0RW3303J609	RESISTOR,FIXED POWER COATED WIRE-WOUND	330K OHM 1 W 5% TA52	SMART,CHOHYANG	R1
58	0RD5603H609	RESISTOR,FIXED CARBON FILM	560K OHM 1/2 W 5% TA52	SMART,CHOHYANG	R2
59	0RS5602K641	RESISTOR,FIXED METAL OXIDE FILM	56K OHM 2 W 5.00% F20	SMART,CHOHYANG	R3
60	0RD6801G609	RESISTOR,FIXED CARBON FILM	6.8K OHM 1/4 W 5.00% TA52	SMART,CHOHYANG	R4
61	0RD0822G609	RESISTOR,FIXED CARBON FILM	82 OHM 1/4 W 5.00% TA52	SMART,CHOHYANG	R5
62	0RD6800G609	RESISTOR,FIXED CARBON FILM	680 OHM 1/4 W 5.00% TA52	SMART,CHOHYANG	R6
63	0RW0101J609	RESISTOR,FIXED POWER COATED WIRE-WOUND	1 OHM 1 W 5% TA52	SMART,CHOHYANG	R0CP
64	0RD1801G609	RESISTOR,FIXED CARBON FILM	1.8K OHM 1/4 W 5.00% TA52	SMART,CHOHYANG	R8
65	0RD1001G609	RESISTOR,FIXED CARBON FILM	1K OHM 1/4 W 5% TA52	SMART,CHOHYANG	R29
66	0RS5602K641	RESISTOR,FIXED METAL OXIDE FILM	56K OHM 2 W 5.00% F20	SMART,CHOHYANG	R10

EXPLANATION FOR MICOM CIRCUIT

No	P/NO	DESCRIPTION	SPEC	MAKER	REMARK
67	ORD0682H609	RESISTOR, FIXED CARBON FILM	68 OHM 1/2 W 5.00% TA52	SMART, CHOHYANG	R67
68	ORD1000G609	RESISTOR, FIXED CARBON FILM	100 OHM 1/4 W 5% TA52	SMART, CHOHYANG	R11
69	ORD1002G609	RESISTOR, FIXED CARBON FILM	10K OHM 1/4 W 5% TA52	SMART, CHOHYANG	R12, 39, 55~57
70	ORD4701G609	RESISTOR, FIXED CARBON FILM	4.7K OHM 1/4 W 5% TA52	SMART, CHOHYANG	R15, 28, 31, 43, 50, 61, 65, 66
71	ORH1001L622	RESISTOR, METAL GLAZED(CHIP)	1K OHM 1/8 W 5% 2012 R/TP	ROHM	R9
72	ORH1004L622	RESISTOR, METAL GLAZED(CHIP)	1M OHM 1/8 W 5% 2012 R/TP	ROHM	R14
73	ORH1002L622	RESISTOR, METAL GLAZED(CHIP)	10K OHM 1/8 W 5% 2012 R/TP	ROHM	R16~23, 46
74	ORH4701L622	RESISTOR, METAL GLAZED(CHIP)	4.7K OHM 1/8 W 5% 2012 R/TP	ROHM	R13, 24~27, 37, 44
75	ORH2001L622	RESISTOR, METAL GLAZED(CHIP)	2K OHM 1/8 W 5% 2012 R/TP	ROHM	R30, 32~35, 52, 53, 54, 58, 62, 63, 64
76	ORD2001G609	RESISTOR, FIXED CARBON FILM	2K OHM 1/4 W 5% TA52	SMART, CHOHYANG	R36, 42, 49, 51, 59, 60
77	ORD1002G609	RESISTOR, FIXED CARBON FILM	10K OHM 1/4 W 5% TA52	SMART, CHOHYANG	RCR1
77	ORD1202G609	RESISTOR, FIXED CARBON FILM	12K OHM 1/4 W 5% TA52	SMART, CHOHYANG	RCR1
77	ORD8201G609	RESISTOR, FIXED CARBON FILM	8.2K OHM 1/4 W 5.00% TA52	SMART, CHOHYANG	RCR1
78	ORD1002G609	RESISTOR, FIXED CARBON FILM	10K OHM 1/4 W 5% TA52	SMART, CHOHYANG	RCF1
78	ORD1202G609	RESISTOR, FIXED CARBON FILM	12K OHM 1/4 W 5% TA52	SMART, CHOHYANG	RCF1
78	ORD8201G609	RESISTOR, FIXED CARBON FILM	8.2K OHM 1/4 W 5.00% TA52	SMART, CHOHYANG	RCF1
79	ORD3901G609	RESISTOR, FIXED CARBON FILM	3.9K OHM 1/4 W 5% TA52	SMART, CHOHYANG	R38, 45
80	ORD3300G609	RESISTOR, FIXED CARBON FILM	330 OHM 1/4 W 5.00% TA52	SMART, CHOHYANG	R40, 47
81	ORD1501H609	RESISTOR, FIXED CARBON FILM	1.5K OHM 1/2 W 5% TA52	SMART, CHOHYANG	R41, 48
82	ORN1622G409	RESISTOR, FIXED METAL FILM	16.2K OHM 1/4 W 1.00% TA52	SMART, CHOHYANG	RF1, R1M1
83	ORN2612G409	RESISTOR, FIXED METAL FILM	26.1K OHM 1/4 W 1.00% TA52	SMART, CHOHYANG	RD1, RR1, RR2
84	ORN9101G409	RESISTOR, FIXED METAL FILM	9.1K OHM 1/4 W 1.00% TA52	SMART, CHOHYANG	RF2
85	ORN2401G409	RESISTOR, FIXED METAL FILM	2.4K OHM 1/4 W 1.00% TA52	SMART, CHOHYANG	RF3
86	ORN1002G409	RESISTOR, FIXED METAL FILM	10K OHM 1/4 W 1.00% TA52	SMART, CHOHYANG	RT1
87	OTRKE00008A	TRANSISTOR, BIPOLARS	KEC KT8151 BK T0126 60V 5A	KEC	Q2, 4
88	OTR319809AA	TRANSISTOR	KTC3198-TP-Y (KTC1815)KEC	KEC	Q3, 5
89	OTR106009AF	TRANSISTOR, BIPOLARS	KRC106M KEC TP TD92M 50V 100MA	KEC	Q1
90	6210JB8001A	FILTER(CIRC), EMC	BFS3510A0 SAMWHA 52 -	SAW WHA	FB1
91	6600RRT001W	SWITCH, TACT	THVV502GAA POSTECH 12V DC 50MA TAPING	POSTECH	SW1
92	6600JB8003A	SWITCH, DIP	3P DIP S/W	DTAX	SW2
93	6854B50001A	JUMP WIRE	0.6MM 52MM TP TAPING SN	DAE A LEAD	J01~15, 18~31, 36, 37, 39~41
94	6854B50001A	JUMP WIRE	0.6MM 52MM TP TAPING SN	DAE A LEAD	JRC1~JCR4
95	6854B50001A	JUMP WIRE	0.6MM 52MM TP TAPING SN	DAE A LEAD	DP1
96	6854B50001A	JUMP WIRE	0.6MM 52MM TP TAPING SN	DAE A LEAD	DP2
97	6854B50001A	JUMP WIRE	0.6MM 52MM TP TAPING SN	DAE A LEAD	JF1, JF2
98	6200JB8001B	FILTER(CIRC), EMC	120+0.1UF PILKOR - -	PILKOR	CR1
99	6200JB8009B	FILTER(CIRC), EMC	CH940050 TNC BK -	TNC	L1
100	6200JB8007X	FILTER(CIRC), EMC	UV11-05320 TNC BK 0.5A 320MH	TNC	L2
101	OLR1001M4F0	INDUCTOR, RADIAL LEAD	1000UH 20% R 6X12.5 BULK	TNC	L3, 4
102	3J02447C	FUSE, DRAWING	15A 250V - EF	SAM JU	FUSE1
103	6901JB8001A	FUSE ASSEMBLY	KDRE -PJT N/S	SAM JU	FUSE HOLDER
104	0FS5001B502	FUSE, SLOW BLOW	5000MA 250 V 5.2X20 LD/GL UL / CSA	SAM JU	FUSE2
105	0Q01030F	CONNECTOR (CIRC), WAFER	GP881191-2 HAN KUK DAN JA NA NA NA	KET	TAB1, 2
106	4920JB3007A	HEAT SINK	23.3*17*25 DRIVE IC STR R-S64, 65, 73 2PIN 1-SCREW 3MM	TAE SUNG	(IC2)
107	1SBF0302418	SCREW TAP TITE(S), BINDING HEAD	+ D3.0 L8.0 MSWR3/FZY	TAE SUNG	(IC2)
108	9VWF0120000	SOLDER(RDSIN WIRE) RSO	D1.20	-	(IC2)
109	49111004	SOLDER, SOLDERING	NA HEESUNG METAL BAR SN 63% NA	HI SUNG	-
110	59333105	FLUX	SGJ0.825-0.830 KOREA F.H-206	KOKI	-
-	<MAGIC-ROOM>	-	-	-	-
111	6630JB8007M	CONNECTOR (CIRC), WAFER	917791-1 AMP 13P 2.5MM RED	AMP	CON9
112	0ITD777400A	IC, DRAWING	TA7774AP 16, SDIP BK DRIVE, IC STEPPING MOTOR	TOSHIBA	IC12
113	0CE105ZK638	CAPACITOR, FIXED ELECTROLYTIC	1UF YK 50V 20% FM5 TP 5	RUBYCON	CE16(85)
114	0CE106ZK638	CAPACITOR, FIXED ELECTROLYTIC	10UF YK 50V 20% FM5 TP 5	RUBYCON	CE17(85)
115	0CK223DK96A	CAPACITOR, FIXED CERAMIC(HIGH DIELECTRIC)	22NF 2012 50V 80%, -20% R/TP X7R	MURATA	CC30, 31
116	ORH1002L622	RESISTOR, METAL GLAZED(CHIP)	10K OHM 1/8 W 5% 2012 R/TP	ROHM	R70
117	ORD1002G609	RESISTOR, FIXED CARBON FILM	10K OHM 1/4 W 5% TA52	SMART, CHOHYANG	R68, 69
118	ORD4701G609	RESISTOR, FIXED CARBON FILM	4.7K OHM 1/4 W 5% TA52	SMART, CHOHYANG	R71
119	ORD2001G609	RESISTOR, FIXED CARBON FILM	2K OHM 1/4 W 5% TA52	SMART, CHOHYANG	R72
120	ORN2612G409	RESISTOR, FIXED METAL FILM	26.1K OHM 1/4 W 1.00% TA52	SMART, CHOHYANG	RR3
121	OTR106009AC	TRANSISTOR, BIPOLARS	KRA106M (KRA2206) KEC TP TD92M 50V 100MA	KEC	Q6~8
122	6854B50001A	JUMP WIRE	0.6MM 52MM TP TAPING SN	DAE A LEAD	J32~35, 38
-	<INTERFACE PORT>	-	-	-	-
123	6630JB8007C	CONNECTOR (CIRC), WAFER	917782-1 AMP 4P 2.5MM STRAIGHT SN	AMP	CON10
124	ORD4700G609	RESISTOR, FIXED CARBON FILM	470 OHM 1/4 W 5% TA52	SMART, CHOHYANG	R73
125	ORH4701L622	RESISTOR, METAL GLAZED(CHIP)	4.7K OHM 1/8 W 5% 2012 R/TP	ROHM	R74
126	0CK102DK96A	CAPACITOR, FIXED CERAMIC(HIGH DIELECTRIC)	1NF 2012 50V 80%, -20% R/TP X7R	MURATA	CC32
127	6854B50001A	JUMP WIRE	0.6MM 52MM TP TAPING SN	DAE A LEAD	J16, 17, 42

EXPLANATION FOR MICOM CIRCUIT

(4) GR-L267BV(T,S)PA (Refer to appendix)

No	P/N	DESCRIPTION	SPEC	MAKER	REMARK
1	6870_BB197A	PMB(PCB)	CHD-PJT GR-L267B(B)F1 BEST,BETTER3	DOO SAN	T-1,6
2	6170_B2013C	TRANSFORMER,SMP3 COIL 1	12V:1.5 16V:1 (220 NARROW)	SAM IL	TRANS
3	6170_B2013D	TRANSFORMER,SMP3 COIL 1	12V:1.5 16V:1 (110 NARROW)	SAM IL	TRANS
4	6630VM0509	CONNECTOR (CIRC),WAFER	YK396-09AV1SP-2,4,6,8I RED	YEON HO	CON2(FED)
5	6630VM02609	CONNECTOR (CIRC),WAFER	YK396-09AV1SP-2,4,6,8I	YEON HO	CON5
6	6630VM02707	CONNECTOR (CIRC),WAFER	YK396-07AV1TP-2,4,6,I	YEON HO	CON3
7	6630VM0111	CONNECTOR (CIRC),WAFER	YK396-11AV11TP-2,4,6,8,10I	YEON HO	CON4
8	6630_BB007R	CONNECTOR (CIRC),WAFER	917788-2 AMP 10P 2.5MM STRAIGHT SN FED	AMP	CON10(FED)
9	6630_BB007N	CONNECTOR (CIRC),WAFER	917792-1 AMP 14P 2.5MM STRAIGHT SN	AMP	CON7
10	6630_BB007J	CONNECTOR (CIRC),WAFER	917788-1 AMP 10P 2.5MM STRAIGHT SN	AMP	CON6
11	6630_BB007K	CONNECTOR (CIRC),WAFER	917789-1 AMP 11P 2.5MM STRAIGHT SN	AMP	CON9(IN/ROOM)
12	6630_BB007L	CONNECTOR (CIRC),WAFER	917790-1 AMP 12P 2.5MM STRAIGHT SN	AMP	CON11(IN/ROOM)
13	6630_BB010A	CONNECTOR (CIRC),WAFER	917791-1 AMP 13P 2.5MM STRAIGHT SN	AMP	CON8
14	01ZZ_B2056P	IC, DRAWING	TMPS7PMAIN 64 SDIP ST OTP CHD-PJT BEST	TOSHIBA	IC1
15	01ZZ_B2056R	IC, DRAWING	TMPS7PMAIN 64 SDIP ST OTP CHD-PJT BETTER3	TOSHIBA	IC1
16	01ZZ_B2049V	IC, DRAWING	TMPS7PBO3N 28 SDIP ST OTP CHD-PJT BEST,BETTER3 SUB	TOSHIBA	IC201
17	01PMGSK001A	IC, POWER MANAGEMENT	STR-G6351 SANKEN 5P ST	SANKEN	IC2
18	01PMNE001A	IC, POWER MANAGEMENT	PS2561-1 NEC 4P,DIP BK : TLP762.F	NEC	IC3,8
19	01KE431000A	IC,KEC	K1A431 3 PIN TP - - -	KEC	IC4
20	01KE780500Z	IC,KEC	K1A7805P1 - - - - -	KEC	IC5
21	01KE650030C	IC,KEC	K1D65003AF 1650P BK 7CH DRIVER	KEC	IC6
22	01KE650830B	IC,KEC	K1D65083AF 2050P BK 8CH DRIVER	KEC	IC7,15
23	01KE704200A	IC,KEC	K1A7042P 3P BK RESET -	KEC	IC9,13
24	01T077400A	IC, TOSHIBA	TA7774AP 16,SDIP BK DRIVE, IC STEPPING MOTOR	TOSHIBA	IC10
25	01T077400A	IC, TOSHIBA	TA7774AP 16,SDIP BK DRIVE, IC STEPPING MOTOR	TOSHIBA	IC11(IN/ROOM)
26	01STLUM01A	IC, STANDARD LOGIC	M54563FP MITSUBISHI 20 R/TP CONVERT	MITSUBISHI	IC14
27	01RH622200A	IC, ROHM	BA6222 10SIP BK REVERSIBLE MOTOR DRIVER	ROHM	IC12
28	6920000001A	RELAY	ALE15B2 MATSUSHITA 250VAC 16A 12VDC IA NO VENTING	MATSUSHITA	
	6920_B2005B	RELAY	G5J5-1A-NT OMRON 250VAC 16A 12VDC IA NO VENTING	OMRON	RY1,RY5,RY7
	6920_B2005C	RELAY	DH1U II DEC. 250VAC 16A 12VDC IA VENTING	DAIICHI	
29	6920AL 2001A	RELAY	AL12B12 NAIS 250VAC 16A 12VDC IC NO VENTING	MATSUSHITA	RY2(R_LAMP)
30	6920AL 2001A	RELAY	AL12B12 NAIS 250VAC 16A 12VDC IC NO VENTING	MATSUSHITA	RY6
3	6920A90002A	RELAY	ALD112 MATSUSHITA 250VAC 3A 12VDC IA	MATSUSHITA	RY4,8,9,10,11,12
	6920_B2003A	RELAY	GN-1A OMRON 250VAC 1.5A 12VDC IA	OMRON	
32	6920A90002A	RELAY	ALD112 MATSUSHITA 250VAC 3A 12VDC IA	MATSUSHITA	RY14(DISP_ LAMP)
	6920_B2003A	RELAY	GN-1A OMRON 250VAC 1.5A 12VDC IA	OMRON	
33	6920A90002A	RELAY	ALD112 MATSUSHITA 250VAC 3A 12VDC IA	MATSUSHITA	RY3(IN/ROOM)
	6920_B2003A	RELAY	GN-1A OMRON 250VAC 1.5A 12VDC IA	OMRON	
34	6920_B2005B	RELAY	G5EB-14 OMRON 250VAC 5A 12VDC IC NO VENTING	OMRON	RY15
35	6920_B2005B	RELAY	G5EB-14 OMRON 250VAC 5A 12VDC IC NO VENTING	OMRON	RY13(IN/BARI)
36	62129M002A	RESONATOR,CERAMIC	CS15040 MURATA 4MHz +/-0.5% TP 15PF	MURATA	OSC1,2
37	6102_BB001A	VARIABLE	SVC6210-14A SAMMHA UL/VDE BK 620V	SAM MHA,IL JIN	VAI
38	610295V006A	VARIABLE	SVC2710-14A SAMMHA UL/CSA/VDE TP 270V	SAM MHA,IL JIN	VAI
39	0DR107009AA	DIODE,RECTIFIERS	FRI07 TP DELTA 0041 1000V IA 3	DELTA	DI_2,14-17
40	0DR107009AA	DIODE,RECTIFIERS	FRI07 TP DELTA 0041 1000V IA 3	DELTA	DI3(OF)
41	0DR107009AA	DIODE,RECTIFIERS	FRI07 TP DELTA 0041 1000V IA 3	DELTA	DI8(IN/ROOM)
42	0DRSAD0090A	DIODE,RECTIFIERS	RL3 SANKEN BK NON 350V 3.5A 80A 50NSEC 0.1MA	SANKEN	
43	0DRSAD0100A	DIODE,RECTIFIERS	S3L40 SHINDENGEN BK AX14 400V 1.8A 60A 50NSEC 10UA	SHINDENGEN	D3,D4
44	0DR360000AA	DIODE,RECTIFIERS	D3SB460 BK SHINDENGEN 600V 4A	SHINDENGEN	BD1
45	0DD400409AC	DIODE,RECTIFIERS	1N4004 TP PYUNGCHANG - - - - -	DELTA,PYUNGCHANG	D5:10
46	0DD400409AC	DIODE,RECTIFIERS	1N4004 TP PYUNGCHANG - - - - -	DELTA,PYUNGCHANG	D5(10M)
47	0DD400709AA	DIODE,RECTIFIERS	1N4007 TP MOTOROLA - - IA - - -	DELTA,PYUNGCHANG	DI2
48	0DD148038E	DIODE,SWITCHING	1N4148 TP ROHM 0035 25V 450MIL	ROHM,PYUNGCHANG	DI1
49	0DD7M00188A	DIODE,ZENERS	RLZ ROHM R/TP 1LDS(ILL)-341 500M 5.6V 20MA .PF	ROHM	DI1_2,3
49	0CE4762V6ED	CAPACITOR,FIXED ELECTROLYTIC	470UF HE 450V 20% BULK SNAP IN	RUBYCON,SAM MHA	CE1(105°C)
50	0CE6862J610	CAPACITOR,FIXED ELECTROLYTIC	680UF HE 400V 20% BULK SNAP IN	RUBYCON,SAM MHA	CE1(105°C)
51	0CE2262K63B	CAPACITOR,FIXED ELECTROLYTIC	220UF YX 50V 20% FMS TP 5	RUBYCON,SAM MHA	CE2(105°C)
52	0CE1082J610	CAPACITOR,FIXED ELECTROLYTIC	1000UF YX 25V 20% BULK FL	RUBYCON,SAM MHA	CE3(105°C)
53	0CE1082J610	CAPACITOR,FIXED ELECTROLYTIC	1000UF YX 35V 0.2 TP 5 FL	RUBYCON,SAM MHA	CE4(105°C)
54	0CE2278F63B	CAPACITOR,FIXED ELECTROLYTIC	220UF 9MS,SG 16V 20% FMS TP 5	RUBYCON,SAM MHA	CE5(85°C)
55	0CE2278F63B	CAPACITOR,FIXED ELECTROLYTIC	220UF KME TYPE 25V 20% FMS TP 5	RUBYCON,SAM MHA	CE10,11(105°C)
56	0CE1068K63B	CAPACITOR,FIXED ELECTROLYTIC	100UF KM TYPE 50V 20% FMS TP 5	RUBYCON,SAM MHA	CE6-9,12,13(85°C)
57	0CE1068K63B	CAPACITOR,FIXED ELECTROLYTIC	100UF KM TYPE 50V 20% FMS TP 5	RUBYCON,SAM MHA	CE16(85°C) (IN/ROOM)
58	0CE1068K63B	CAPACITOR,FIXED ELECTROLYTIC	10UF 9MS,SG 50V 20% FMS TP 5	RUBYCON,SAM MHA	CE14(85°C)
59	0CE1068K63B	CAPACITOR,FIXED ELECTROLYTIC	10UF 9MS,SG 50V 20% FMS TP 5	RUBYCON,SAM MHA	CE15(85°C) (IN/ROOM)
60	0CE4776H63B	CAPACITOR,FIXED ELECTROLYTIC	470UF 9MS,SG 25V 20% FMS TP 5	RUBYCON,SAM MHA	CE18(85°C)
61	0CE1074H63B	CAPACITOR,FIXED ELECTROLYTIC	1000UF YK 25V 20% FMS TP 5	RUBYCON,SAM MHA	CE17(85°C)
62	0CF33408670	CAPACITOR,FIXED FILM	3300F 275VAC	PILKOR	CM1
63	0CF22408670	CAPACITOR,FIXED FILM	2200F 275VAC	PILKOR	CM2
64	0CD4732Y430	CAPACITOR,FIXED FILM	47000PF 5.630V 5% MPE NI R	SEIL	CM3
65	0CD2231N409	CAPACITOR,FIXED FILM	0.022UF 0.100V .J FF TP	SAMMHA	CM4
66	0CK2202Q51	CAPACITOR,FIXED CERAMIC(High dielectric)	220P 20V K B 5	SAM MHA, DOOSAN	CC2
67	0CX2240K94A	CAPACITOR,FIXED CERAMIC(High dielectric)	220NF 2012 50V 80%, -20% F(Y5V) R/TP	MURATA	CC3
68	0CX1040K94A	CAPACITOR,FIXED CERAMIC(High dielectric)	100NF 2012 50V 80%, -20% R/TP F(Y5V)	MURATA	CC4-6,8,9,11,25-34,36,37
69	0CX2230K96A	CAPACITOR,FIXED CERAMIC(High dielectric)	22NF 2012 50V 80%, -20% R/TP X7R	MURATA	CC7,10,12-17,19,21-23,35
70	0CX2230K96A	CAPACITOR,FIXED CERAMIC(High dielectric)	22NF 2012 50V 80%, -20% R/TP X7R	MURATA	CC24(IN/ROOM)
71	0CX1020K96A	CAPACITOR,FIXED CERAMIC(High dielectric)	10NF 2012 50V 80%, -20% R/TP X7R	MURATA	CC18,20,38
72	0CX470K96A	CAPACITOR,FIXED CERAMIC(High dielectric)	0.0047UF 2012 50V 80%, -20% R/TP X7R	MURATA	CC1

EXPLANATION FOR MICOM CIRCUIT

No	P/NO	DESCRIPTION	SPEC	MAKER	REMARK
73	0RS3303609	RESISTOR, FIXED METAL OXIDE FILM	330K OHM 1 W 5% TA52	SMART, CHOHYANG	R1
74	0RS5602609	RESISTOR, FIXED CARBON FILM	560K OHM 1/2 W 5.00% TA52	SMART, CHOHYANG	R2
75	0RS5602K641	RESISTOR, FIXED METAL OXIDE FILM	56K OHM 2 W 5.00% F20	SMART, CHOHYANG	R3
76	0R068016609	RESISTOR, FIXED CARBON FILM	6.8K OHM 1/4 W 5.00% TA52	SMART, CHOHYANG	R4
77	0R0120016609	RESISTOR, FIXED CARBON FILM	120 OHM 1/4 W 5.00% TA52	SMART, CHOHYANG	R5
78	0R008226609	RESISTOR, FIXED CARBON FILM	82 OHM 1/4 W 5.00% TA52	SMART, CHOHYANG	R6
79	0R068006609	RESISTOR, FIXED CARBON FILM	680 OHM 1/4 W 5.00% TA52	SMART, CHOHYANG	R6
80	0R047016609	RESISTOR, FIXED POWER COATED WIRE-WOUND	0.47 OHM 1 W 5% TA52	SMART, CHOHYANG	ROCP
80	0R056016609	RESISTOR, FIXED POWER COATED WIRE-WOUND	0.56 OHM 1 W 5% TA52	SMART, CHOHYANG	ROCP
81	0R010016609	RESISTOR, FIXED POWER COATED WIRE-WOUND	1 OHM 1 W 5% TA52	SMART, CHOHYANG	ROCP
81	0R018016609	RESISTOR, FIXED CARBON FILM	1.8K OHM 1/4 W 5.00% TA52	SMART, CHOHYANG	R8
82	0R010016609	RESISTOR, FIXED CARBON FILM	1K OHM 1/4 W 5.00% TA52	SMART, CHOHYANG	R9, 26, 67
83	0R091016409	RESISTOR, FIXED METAL FILM	9.1K OHM 1/4 W 1.00% TA52	SMART, CHOHYANG	RF2
84	0R024016409	RESISTOR, FIXED METAL FILM	2.4K OHM 1/4 W 1.00% TA52	SMART, CHOHYANG	RF3
85	0RS5602K641	RESISTOR, FIXED METAL OXIDE FILM	56K OHM 2 W 5.00% F20	SMART, CHOHYANG	R10
86	0R010026609	RESISTOR, FIXED CARBON FILM	10K OHM 1/4 W 5.00% TA52	SMART, CHOHYANG	R16, 17, 20, 21, 56, 57, 58
87	0R047016609	RESISTOR, FIXED CARBON FILM	4.7K OHM 1/4 W 5.00% TA52	SMART, CHOHYANG	R14, 15, 24, 28, 38, 45, 68, 73, 83
88	0R047016609	RESISTOR, FIXED CARBON FILM	4.7K OHM 1/4 W 5.00% TA52	SMART, CHOHYANG	R62 (M/ROOM)
89	0R020016609	RESISTOR, FIXED CARBON FILM	2K OHM 1/4 W 5.00% TA52	SMART, CHOHYANG	R29, 33, 43, 50, 52, 54, 69, 72, 74, 75, 85, 88, 103
90	0R020016609	RESISTOR, FIXED CARBON FILM	2K OHM 1/4 W 5.00% TA52	SMART, CHOHYANG	R36 (OF)
91	0R020016609	RESISTOR, FIXED CARBON FILM	2K OHM 1/4 W 5.00% TA52	SMART, CHOHYANG	R65 (M/ROOM)
92	0R020016609	RESISTOR, FIXED CARBON FILM	2K OHM 1/4 W 5.00% TA52	SMART, CHOHYANG	R63 (M/ROOM)
93	0R039016609	RESISTOR, FIXED CARBON FILM	3.9K OHM 1/4 W 5.00% TA52	SMART, CHOHYANG	R39, 46
94	0R015016609	RESISTOR, FIXED CARBON FILM	1.5K OHM 1/2 W 5.00% TA52	SMART, CHOHYANG	R42, 49
95	0R010006609	RESISTOR, FIXED CARBON FILM	100 OHM 1/4 W 5% TA52	SMART, CHOHYANG	R104
96	0R006826609	RESISTOR, FIXED CARBON FILM	68 OHM 1/2 W 5.0% TA52	SMART, CHOHYANG	R78
97	0R010026609	RESISTOR, FIXED CARBON FILM	10K OHM 1/4 W 5.00% TA52	SMART, CHOHYANG	RF9-61 (M/ROOM)
98	0R01000.622	RESISTOR, METAL GLAZED (CHIP)	100 OHM 1 / 8 W 5% 2012 R/T/P	ROHM	R11
99	0R01004.622	RESISTOR, METAL GLAZED (CHIP)	1M OHM 1 / 8 W 2012 5.00% D	ROHM	R13, 82
100	0R01002.622	RESISTOR, METAL GLAZED (CHIP)	10K OHM 1/8 W 5% 2012 R/T/P	ROHM	R12, 18, 19, 22, 23, 40, 47
101	0R02001.622	RESISTOR, METAL GLAZED (CHIP)	2K OHM 1 / 8 W 2012 5.00% D	ROHM	R27, 34, 55, 66, 84
102	0R04701.622	RESISTOR, METAL GLAZED (CHIP)	4.7K OHM 1 / 8 W 2012 5.00% D	ROHM	R25, 35, 44, 51, 76, 77, 79-81, 86, 89-95, 105
103	0R03300.622	RESISTOR, METAL GLAZED (CHIP)	330 OHM 1 / 8 W 2012 5.00% D	ROHM	R41, 48
104	0R03300.622	RESISTOR, METAL GLAZED (CHIP)	330 OHM 1 / 8 W 2012 5.00% D	ROHM	R37 (OF)
105	0R03300.622	RESISTOR, METAL GLAZED (CHIP)	330 OHM 1 / 8 W 2012 5.00% D	ROHM	R64 (M/ROOM)
106	0R01001.622	RESISTOR, METAL GLAZED (CHIP)	1K OHM 1/8 W 5% 2012 R/T/P	ROHM	R87
107	0R010026609	RESISTOR, FIXED CARBON FILM	10K OHM 1/4 W 5.00% TA52	SMART, CHOHYANG	RCR1
107	0R012026609	RESISTOR, FIXED CARBON FILM	12K OHM 1/4 W 5.00% TA52	SMART, CHOHYANG	RCR1
107	0R082016609	RESISTOR, FIXED CARBON FILM	8.2K OHM 1/4 W 5.00% TA52	SMART, CHOHYANG	RCR1
108	0R010026609	RESISTOR, FIXED CARBON FILM	10K OHM 1/4 W 5.00% TA52	SMART, CHOHYANG	RCF1
109	0R01002.422	RESISTOR, METAL GLAZED (CHIP)	10K OHM 1/8 W 1% 2012 R/T/P	ROHM	RT1
110	0R01622E472	RESISTOR, METAL GLAZED (CHIP)	16.2K OHM 1 / 8 W 2012 1.00% D	ROHM	RF1, R1M1
111	0R02612E472	RESISTOR, METAL GLAZED (CHIP)	26.1K OHM 1 / 8 W 2012 1.00% D	ROHM	RF1, RF1, RF2, R1M1
112	0R02612K409	RESISTOR, FIXED METAL FILM	26.1K OHM 1/4 W 1.00% TA52	SMART, CHOHYANG	RF3 (M/ROOM)
113	0R027004609	RESISTOR, FIXED CARBON FILM	270 OHM 1/2 W 5.00% TA52	SMART, CHOHYANG	R96-102
114	0TR0E00008A	TRANSISTOR, BIPOLARS	KEC KT8151 BK 10126 60V 5A	KEC	04, 06
115	0TR39909CA	TRANSISTOR	KTC399-TP-Y (KTC0815)KEC	KEC	05, 07
116	0TR106009AF	TRANSISTOR, BIPOLARS	KPC 106M KEC	KEC	01, 10, 11
117	0TR106009AF	TRANSISTOR, BIPOLARS	KPC 106M KEC	KEC	02 (OF)
118	0TR106009AF	TRANSISTOR, BIPOLARS	KPC 106M KEC	KEC	08 (M/ROOM)
119	0TR127309AD	TRANSISTOR	KTA1273-Y (KTA966A) TP KEC - -	KEC	09 (M/ROOM)
120	0TR127309AD	TRANSISTOR	KTA1273-Y (KTA966A) TP KEC - -	KEC	03 (OF)
121	6200.88001A	FILTER (CIRC), EMC	BFS351040 SAMIHA 52 -	SAM IHA	FBI
122	6600R1001M	SWITCH, TACT	THV5026AA POSTECH 12V DC 50MA TAPING	POSTECH	SW1
123	6600.88003A	SWITCH, DIP	3P DIP 5/M	OTAX	SW2
124	6854850001A	JUMP WIRE	0.6MM 1521MM TP TAPING SN	DAE A LEAD	J01-J43
125	6854850001A	JUMP WIRE	0.6MM 1521MM TP TAPING SN	DAE A LEAD	JCR1-JCR4
126	6854850001A	JUMP WIRE	0.6MM 1521MM TP TAPING SN	DAE A LEAD	JF1, JF2
127	6854850001A	JUMP WIRE	0.6MM 1521MM TP TAPING SN	DAE A LEAD	JP1
128	6854850001A	JUMP WIRE	0.6MM 1521MM TP TAPING SN	DAE A LEAD	OP1
129	6854850001A	JUMP WIRE	0.6MM 1521MM TP TAPING SN	DAE A LEAD	OP2
130	6854850001A	JUMP WIRE	0.6MM 1521MM TP TAPING SN	DAE A LEAD	OP3
131	6854850001A	JUMP WIRE	0.6MM 1521MM TP TAPING SN	DAE A LEAD	OP4
132	6854850001A	JUMP WIRE	0.6MM 1521MM TP TAPING SN	DAE A LEAD	OP5
133	6200.88000B	FILTER (CIRC), EMC	120x0.1UF PILKOR - -	PILKOR	CR1
134	6200.88009B	FILTER (CIRC), EMC	CH40050 TNC BK	TNC	L1
135	6200.88007X	FILTER (CIRC), EMC	UV11-05320 TNC BK 0.5A 32MH	TNC	L2
136	0L01000MFO	INDUCTOR, RADIAL LEAD	1000UH 20% R 6X12.5 BULK	TNC	L3, 4
137	0F550018502	FUSE, SLOW BLOW	5000MA 250 V 5.2X20 LD/GL UL / CSA	SAM JU	FUSE2
138	3J02447C	FUSE, DRAWING	15A 250V - EF	SAM JU	FUSE1
139	6901.88001A	FUSE ASSEMBLY	KOPE-PJT N/S	SAM JU	FUSE HOLDER
140	4920.83007A	HEAT SINK	23.3x17x25 DRIVE IC STR R-S64,66,73 2PIN I-SCREW 3MM	TAE SUNG	(IC2)
141	159F0302418	SCREW	+ D3.0 L8.0 M6NFB/FZY	-	(IC2)
142	9W1F0120000	SOLDER (ROSN WIRE) R50	DI_20	-	-
143	49111004	SOLDER, SOLDERING	H63A	HI SUNG	-
144	59331005	FLUX	SG10.825-0.830 KOPEA F.H-206	KOKI	-
145	0001030F	CONNECTOR (CIRC), WAFER	GP88191-2 HAN KUK DAN JA NA NA NA	KET	TAB1, 2
146					

EXPLANATION FOR MICOM CIRCUIT

(3) GR-L267BV(T)RA, GR-L267BV(T,S)PA (Refer to appendix)

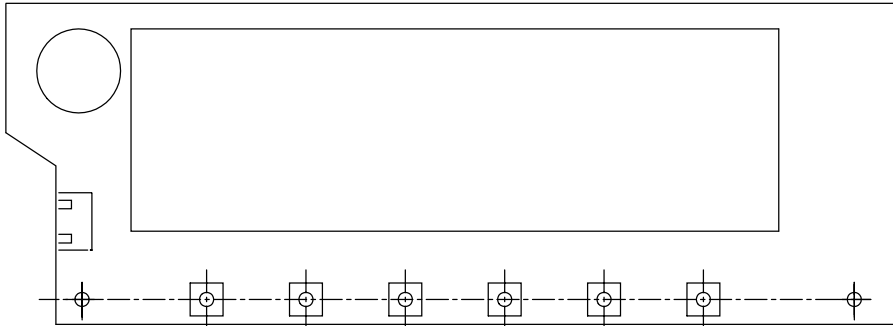

F	E	D	C	B	A	WDRK					
CH-PJT DLX NAESU(QF)	CH-PJT DLX NAESU(QF/JET)	CH-PJT DLX EXPORT(QF)	CH-PJT DLX EXPORT(QF/JET)	CH-PJT DLX USAG(QF)	CH-PJT DLX USAG(QF/JET)		APPLCATION				
Qty	Qty	Qty	Qty	Qty	Qty	No	P/NO	DESCRIPTION	SPEC	MAKER	REMARK
-	-	-	-	-	-	1	-	PWB(PCB)	03 USA MODULE DISPLAY PCB	DDOSAN	FR4
1	1	1	1	1	1	2	-	PWB(PCB)	03 NAESU/EXPORT MODULE DISPLAY PCB	DDOSAN	FR4
-	-	-	-	-	-	3	-	REFLECTOR	03 USA PC-ABS	SEJUL	-
-	-	-	-	-	-	4	-	REFLECTOR	03 NAESU/EXPORT PC-ABS	SEJUL	-
-	-	-	-	-	-	5	4140JB1028A	NAME PLATE_P(CH)	03 CH-PJT QF/JET MODULE USA	SEJUL	-
-	-	-	-	-	-	6	4140JB1028B	NAME PLATE_P(CH)	03 CD2-PJT/CH-PJT QF MODULE USA	SEJUL	-
-	-	-	-	-	-	7	4140JB1028C	NAME PLATE_P(CH)	03 CH-PJT QF/JET MODULE EXPORT	SEJUL	-
-	-	-	-	-	-	8	4140JB1028D	NAME PLATE_P(CH)	03 CD2-PJT/CH-PJT QF MODULE EXPORT	SEJUL	-
-	-	-	-	-	-	9	4140JB1028E	NAME PLATE_P(CH)	03 CH-PJT QF/JET MODULE NAESU	SEJUL	-
-	-	-	-	-	-	10	4140JB1028F	NAME PLATE_P(CH)	03 CH-PJT QF MODULE NAESU	SEJUL	-
1	1	1	1	1	1	11	6630JB8005C	CONNECTOR (CIRC),WAFER	SMAV250-04	YEON HD	CON101
-	-	-	-	-	-	12	-	-	-	-	-
1	1	1	1	1	1	13	01ZZJB2036Q	IC_DRAWING	TMP87CH47U 44P,QFP44-P-1010 TRAY CH-PJT USA	TOSHIBA	IC10(Q=R)
-	-	-	-	-	-	14	-	-	-	-	-
-	-	-	-	-	-	15	-	-	-	-	-
-	-	-	-	-	-	16	-	-	-	-	-
-	-	-	-	-	-	17	-	-	-	-	-
-	-	-	-	-	-	18	-	-	-	-	-
-	-	-	-	-	-	19	-	-	-	-	-
1	1	1	1	1	1	20	01STLM1001A	IC_STANDARD LOGIC	M54563FP MITSUBISHI 20 R/TP CONVERT	MITSUBISHI	IC105
2	2	2	2	2	2	21	01KE650030C	IC_KEC	K1D65003AF 16SDP BK 7CH DRIVER	KEC	IC106,107
-	-	-	-	-	-	22	-	-	-	-	-
1	1	1	1	1	1	23	01STLKE002A	IC_STANDARD LOGIC	K1A78L05F KEC SOT-89 TP REGULATOR	KEC	IC102
1	1	1	1	1	1	24	01STLKE003A	IC_STANDARD LOGIC	K1A7042AF KEC SOT-89 TP RESET IC	KEC	IC103
1	1	1	1	1	1	25	01RH934600D	IC_RDHM	BR93LC46RF-W 8PIN SDP BK EEPROM	ROHM	IC104
1	1	1	1	1	1	26	01STLKE004A	IC_STANDARD LOGIC	KRA106S KEC SOT-23 TP TRANSISTOR	KEC	Q104
3	3	3	3	3	3	27	01STLKE005A	IC_STANDARD LOGIC	KRC106S KEC SOT-23 TP TRANSISTOR	KEC	Q101-103
-	-	-	-	-	-	28	-	-	-	-	-
-	-	-	-	-	-	29	-	-	-	-	-
1	1	1	1	1	1	30	6212BB3245A	RESONATOR,CERAMIC	CSTCR4M00G53-R0 MURATA 4.0MHZ +/- 0.5% T/R SMD	MURATA	DSC101
-	-	-	-	-	-	31	-	-	-	-	-
-	-	-	-	-	-	32	-	-	-	-	-
2	2	2	2	2	2	33	0CE107VF6DC	CAPACITOR,FIXED ELECTR	100UF MV 16V 20% R/TP(SMD) SMD	SAMHWA	CE101,102
1	1	1	1	1	1	34	0CE476VF6DC	CAPACITOR,FIXED ELECTR	47UF MV 16V 20% R/TP(SMD) SMD	SAMHWA	CE103
-	-	-	-	-	-	35	-	-	-	-	-
-	-	-	-	-	-	36	-	-	-	-	-
8	8	8	8	8	8	37	0CK104DK94A	CAPACITOR,FIXED CERAMI	100NF 2012 50V 80%,-20% R/TP F(Y5V)	MURATA	CC101-108
1	1	1	1	1	1	38	0CK102DK96A	CAPACITOR,FIXED CERAMI	1NF 2012 50V 80%,-20% R/TP X7R	MURATA	CC109
1	1	1	1	1	1	39	0RH1000L622	RESISTOR,METAL GLAZEDC	100 OHM 1/8 W 2012 5.00% D	ROHM	R123
1	1	1	1	1	1	40	0RD2200E672	RESISTOR,METAL GLAZEDC	220 OHM 1/8 W 5% 2012 R/TP	ROHM	R106
2	2	2	2	2	2	41	0RD1001E672	RESISTOR,METAL GLAZEDC	1K OHM 1/8 W 5% 2012 R/TP	ROHM	R102,107
2	2	2	2	2	2	42	0RD2001E672	RESISTOR,METAL GLAZEDC	2K OHM 1/8 W 5% 2012 R/TP	ROHM	R101,122
6	6	6	6	6	6	43	0RD4701E672	RESISTOR,METAL GLAZEDC	4.7K OHM 1/8 W 5% 2012 R/TP	ROHM	R103,104,108-110,125
1	1	1	1	1	1	44	0RD1004E672	RESISTOR,METAL GLAZEDC	1M OHM 1/8 W 5% 2012 R/TP	ROHM	R105
-	-	-	-	-	-	45	-	-	-	-	-
1	1	1	1	1	1	46	0RJ0682G676	RESISTOR,METAL GLAZEDC	68 OHM 1/4 W 3216 5.00% D	ROHM	R124
3	3	3	3	3	3	47	0RJ2700H680	RESISTOR,METAL GLAZEDC	270 OHM 1/2 W 5025 5.00% D	ROHM	R119-121
7	7	7	7	7	7	48	0RJ3300H680	RESISTOR,METAL GLAZEDC	330 OHM 1/2 W 5025 5.00% D	ROHM	R111-117
-	-	-	-	-	-	49	0RJ3300H680	RESISTOR,METAL GLAZEDC	330 OHM 1/2 W 5025 5.00% D	ROHM	R118
-	-	-	-	-	-	50	0RJ0000E672	RESISTOR,METAL GLAZEDC	0 OHM 1/8 W 5% 2012 R/TP	ROHM	DP1(EXPORT/NAESU)
-	-	-	-	-	-	51	0RJ0000E672	RESISTOR,METAL GLAZEDC	0 OHM 1/8 W 5% 2012 R/TP	ROHM	DP2(JET/EXPRESS)
-	-	-	-	-	-	52	0RJ0000E672	RESISTOR,METAL GLAZEDC	0 OHM 1/8 W 5% 2012 R/TP	ROHM	DP3(USA/EXTRA)
1	1	1	1	1	1	53	0B7RM00189A	DIODE,ZENERS	R1Z RDHM R/TP LLDSC(LL-34) 500MW 5.6V 20MA PF	ROHM	ZD101
6	6	6	6	6	6	54	0DRM00028A	DIODE,RECTIFIERS	RLR4004 RDHM R/TP SOT23 400V 1A 20A_SEC 10MA	ROHM	D101-106
6	6	6	6	6	6	55	0DSRM00068A	DIODE,SWITCHING	RLS4148 RDHM R/TP LLDSC(LL-34) 75V 450MA 2000MA	ROHM	D107-112
-	-	-	-	-	-	56	-	-	-	-	-
-	-	-	-	-	-	57	0DLLE0048AA	LED	GREEN/YELLOW(3#)	SEJUL	L158-173(RT)
51	51	51	51	51	51	58	0DLLE0048AA	LED	GREEN/YELLOW(3#)	SEJUL	L101-131,134-147,150-153,176,177
-	-	-	-	-	-	59	0DLLE0048AA	LED	GREEN/YELLOW(3#)	SEJUL	L154-157(LAMP)
2	2	2	2	2	2	60	0DLLE0048AA	LED	GREEN/YELLOW(3#)	SEJUL	L178,179(UNLDC)
-	-	-	-	-	-	61	0DLLE0048AA	LED	GREEN/YELLOW(3#)	SEJUL	L132,133,148,149,174,175
-	-	-	-	-	-	62	-	-	-	-	-
-	-	-	-	-	-	63	-	-	-	-	-
1	1	1	1	1	1	64	6908JB8003A	BUZZER,PIEZO CERAMIC	BM-20B BUJEON PIEZO 4KHZ 85DB	BUJEON	BUZZER
6	6	6	6	6	6	65	6600RR1002J	SWITCH,TACT	JTP1138A JEIL 12VDC 50MA SMD	JEIL	SW101-106
-	-	-	-	-	-	66	-	-	-	-	-
20	20	20	20	20	20	67	49111001	SOLDER,SOLDERING	SOLDER(RDSIN WIRE)RSD	HUISUNG	-
50	50	50	50	50	50	68	49111004	SOLDER,SOLDERING	H63A	HUISUNG	-
50	50	50	50	50	50	69	59333105	FLUX	SGJ0.825-0.830 KOREA F.H-206	KOKI	-
-	-	-	-	-	-	70	-	-	-	-	-
-	-	-	-	-	-	71	-	-	-	-	-
-	-	-	-	-	-	72	-	-	-	-	-

EXPLANATION FOR MICOM CIRCUIT

2-4. DISPLAY circuit diagram

(1) GR-L267BV(T)R (Refer to appendix)

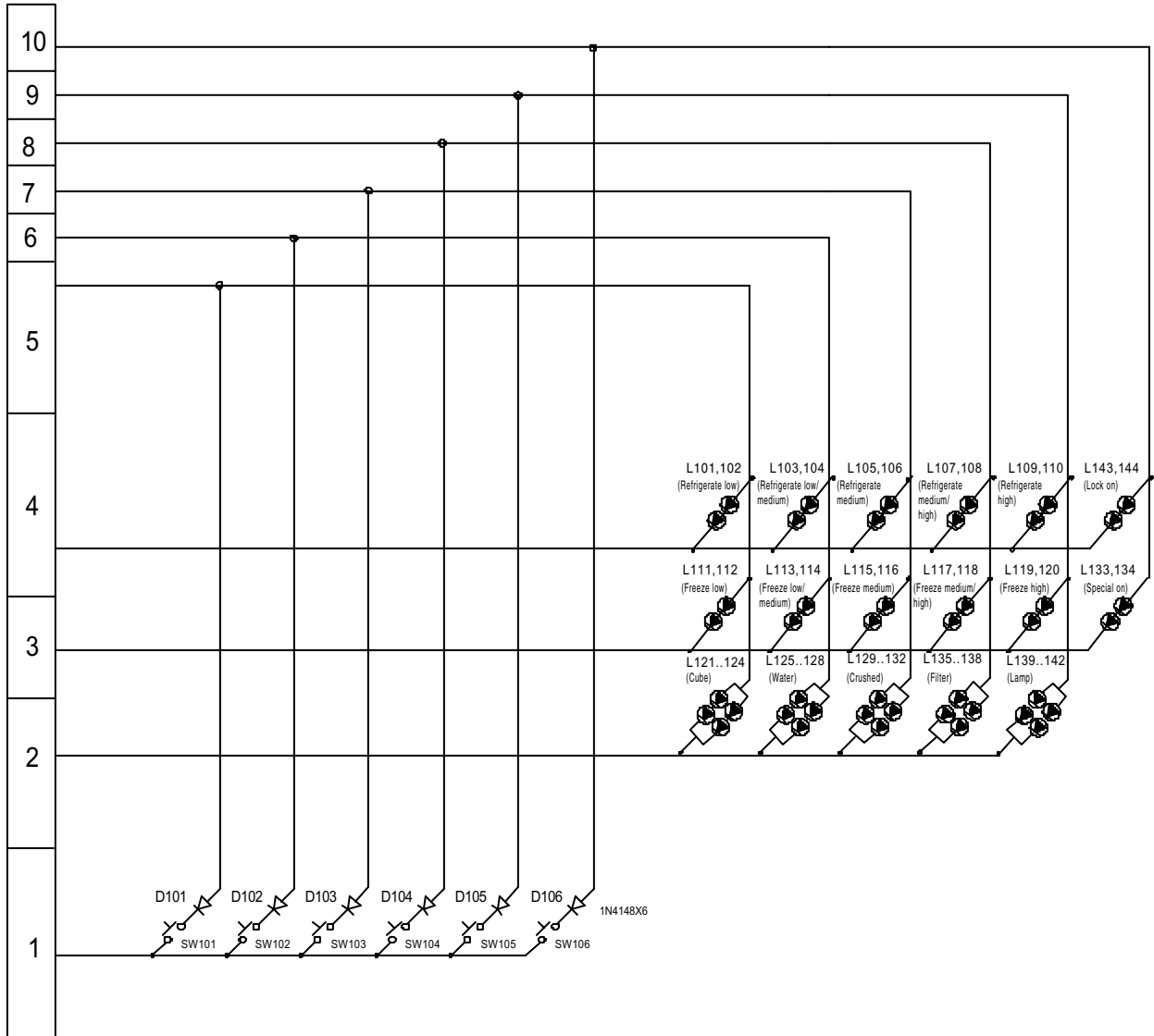

EXPLANATION FOR MICOM CIRCUIT

(2) GR-L267BNRY (Refer to appendix)

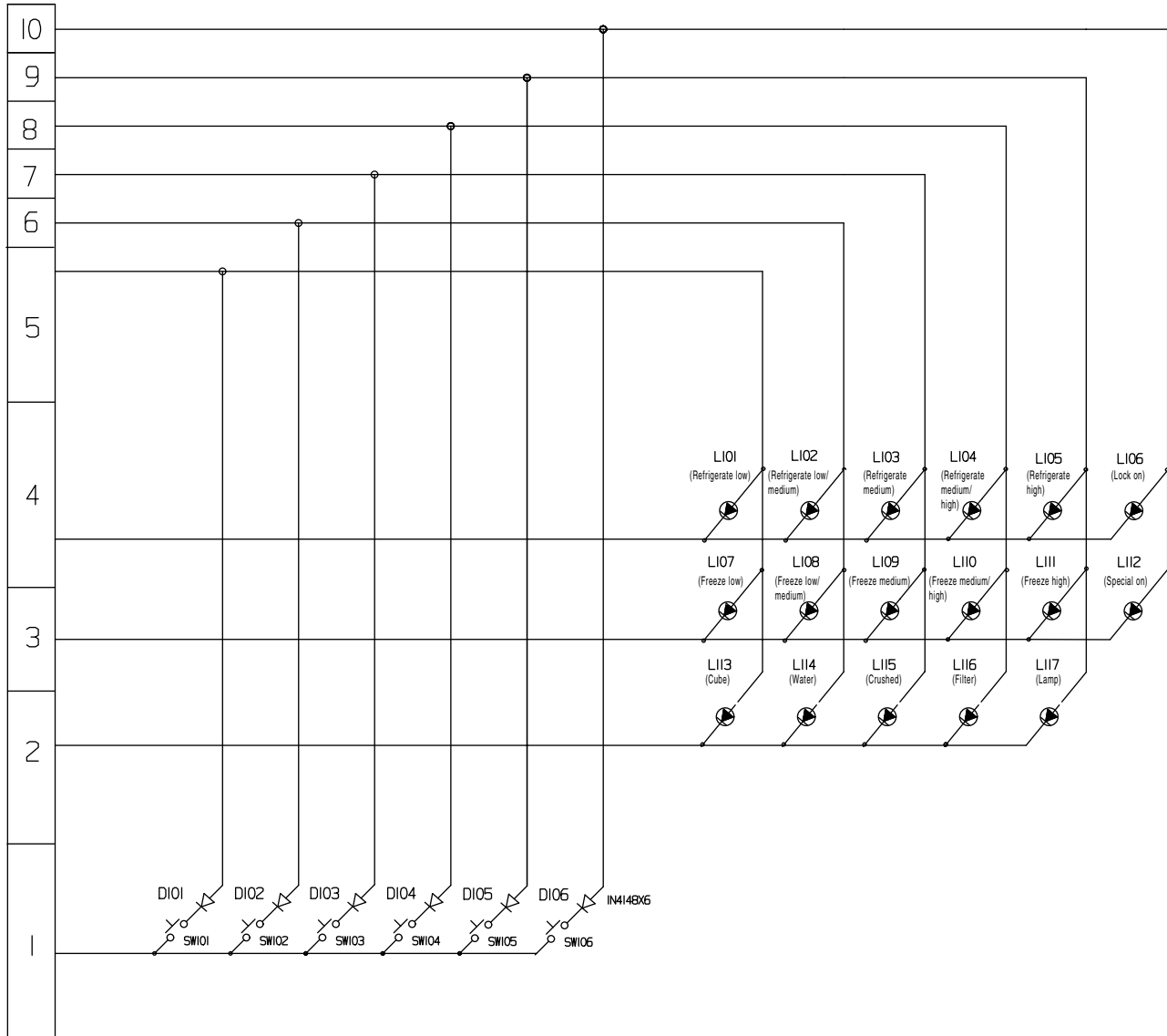

EXPLANATION FOR MICOM CIRCUIT

(3)GR-L267BV(T)RA, GR-L267BV(T,S)PA (Refer to appendix)

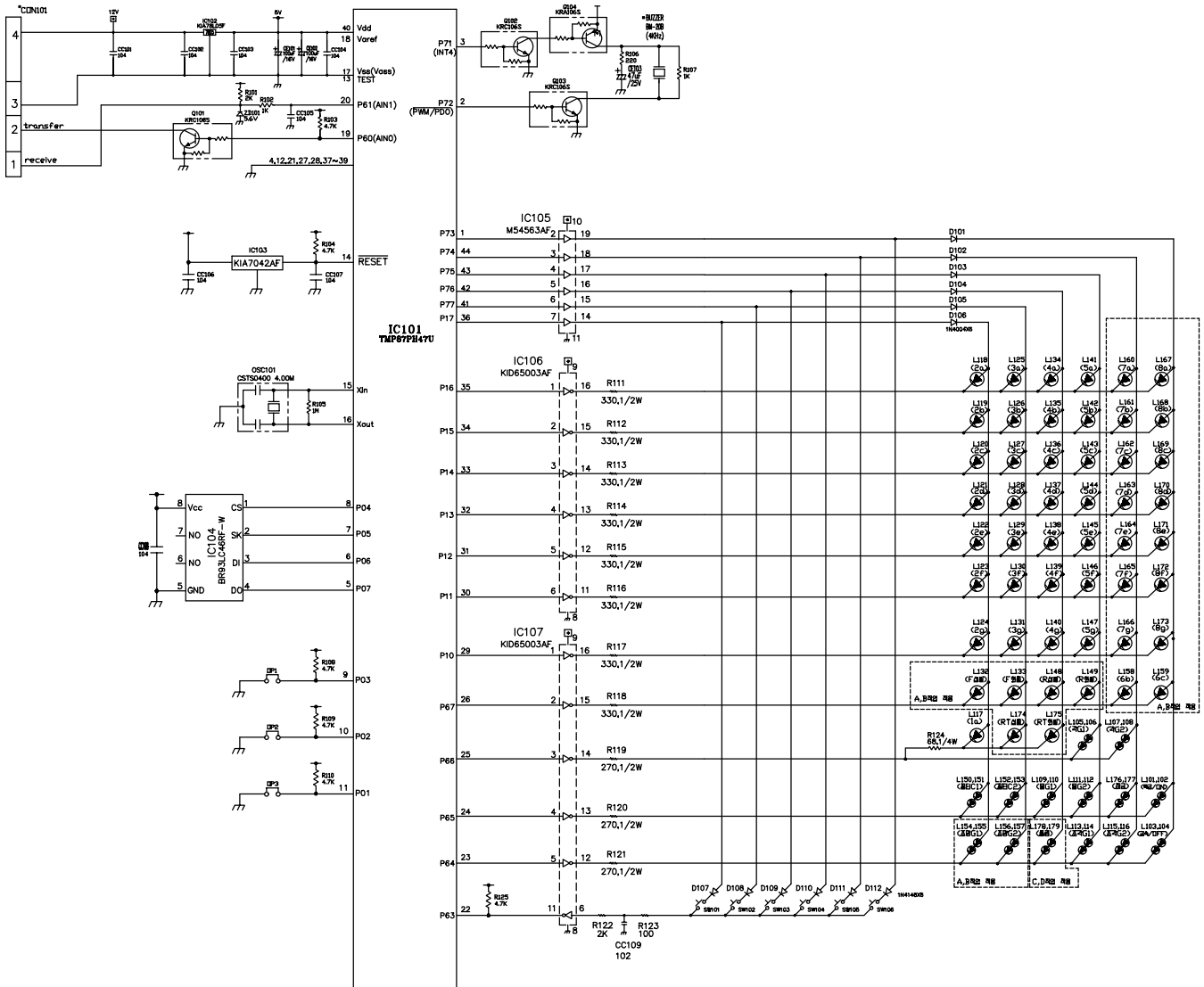

EXPLANATION FOR MICOM CIRCUIT

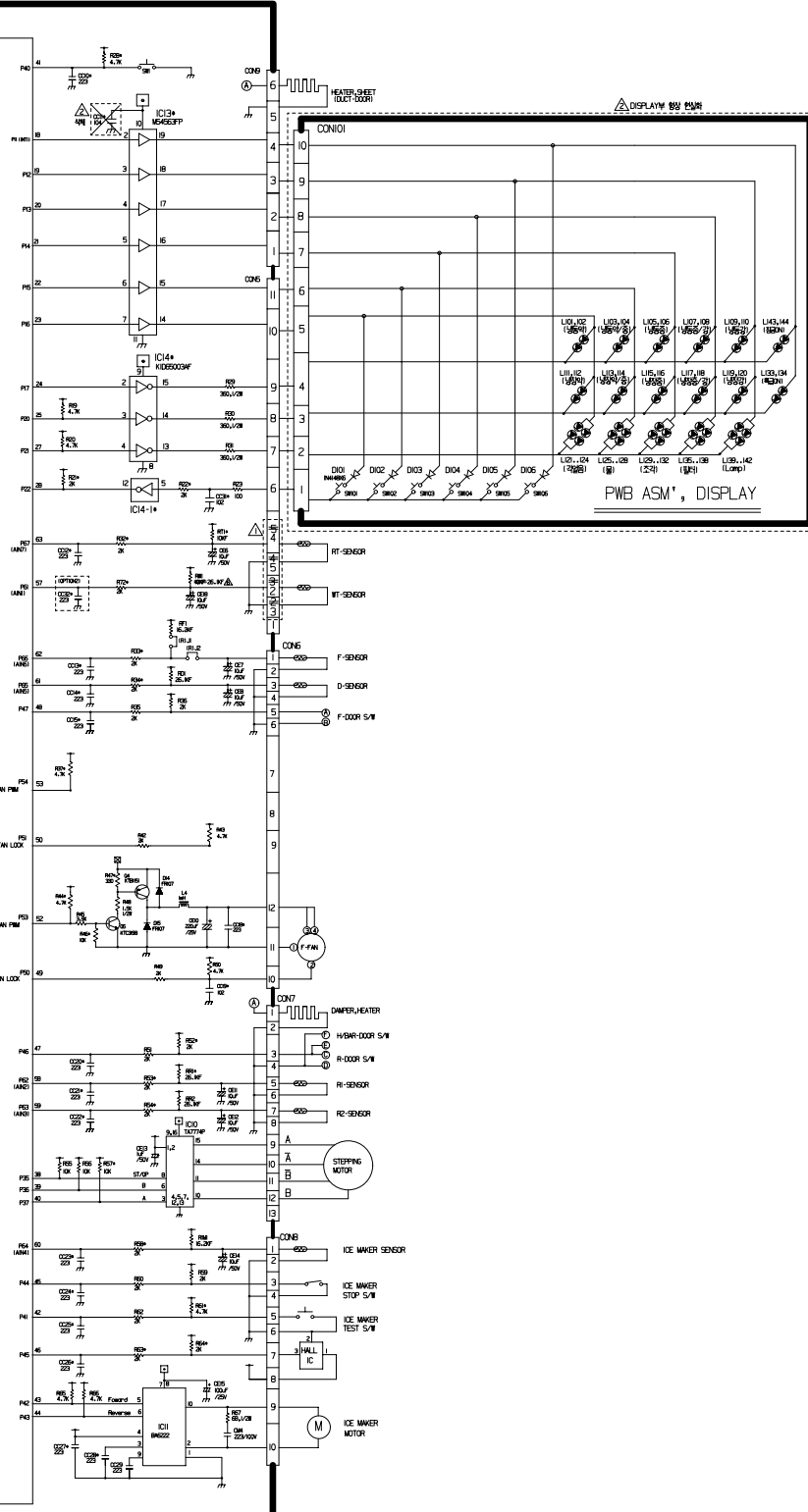

EXPLANATION FOR MICOM CIRCUIT

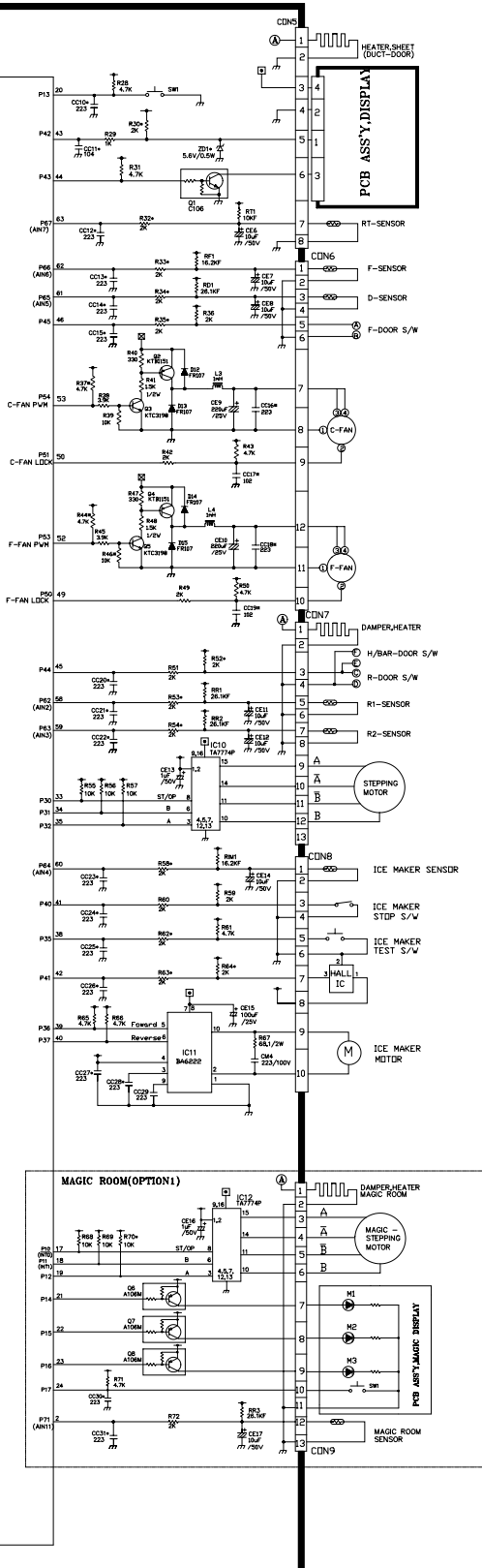

EXPLANATION FOR MICOM CIRCUIT

(4) GR-L267BV(T,S)PA (Refer to appendix)

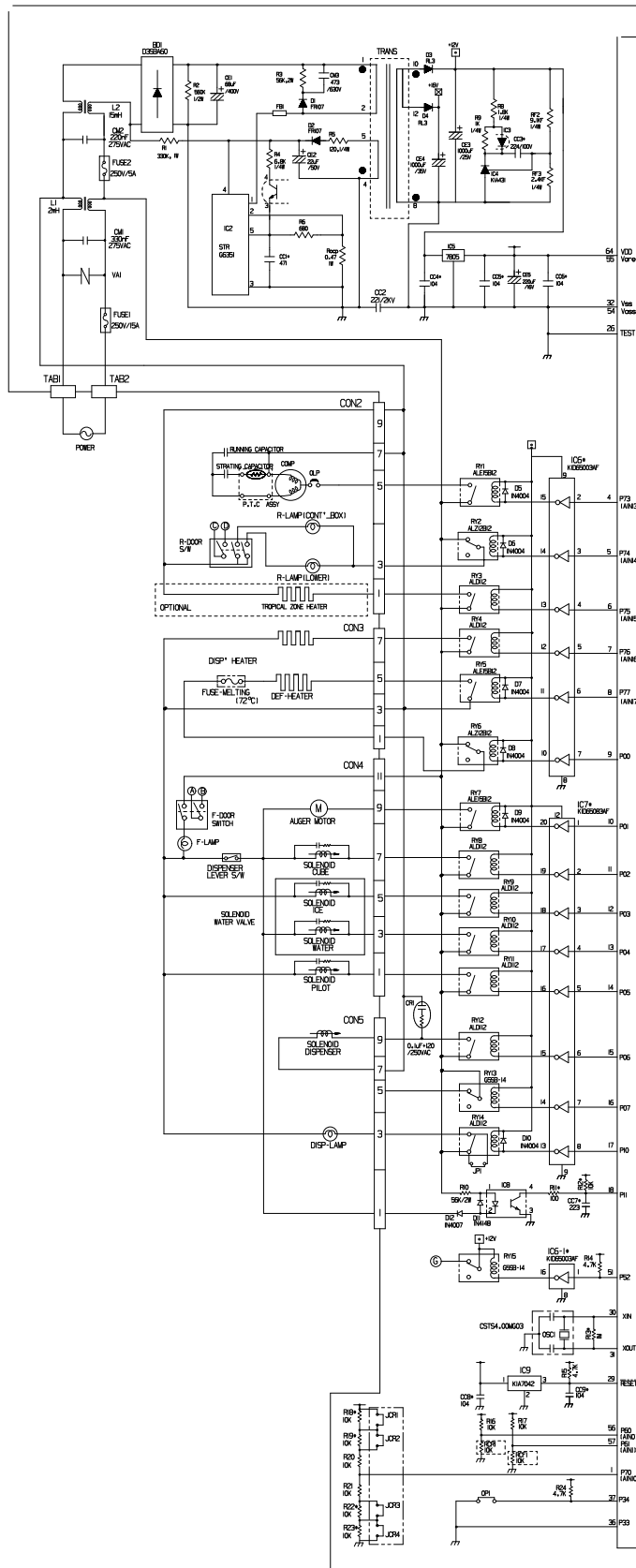

EXPLANATION FOR MICOM CIRCUIT

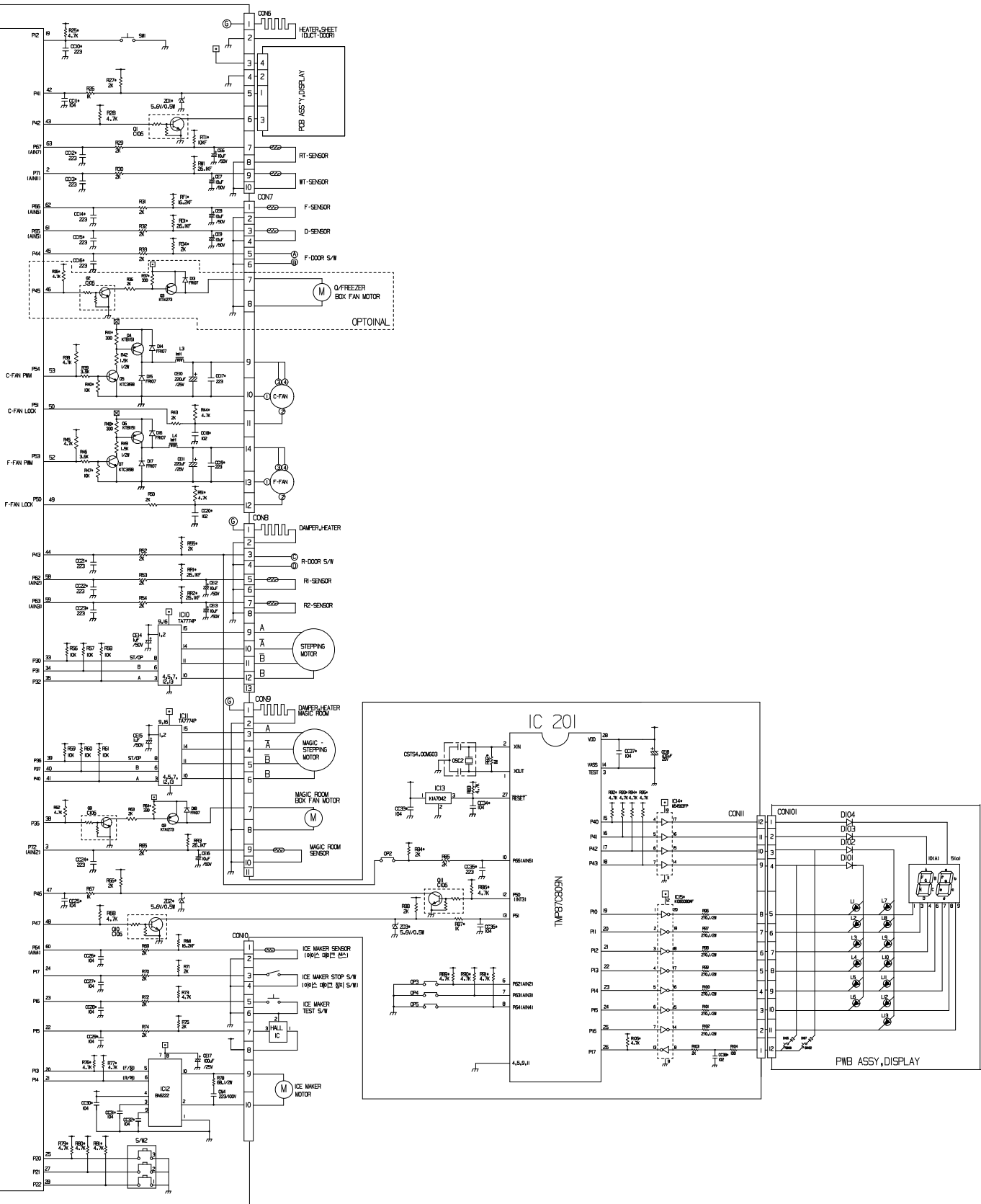

ICEMAKER AND DISPENSER WORKING PRINCIPLES AND REPAIR

1. Working Principles

1-1. ICEMaker Working Principles

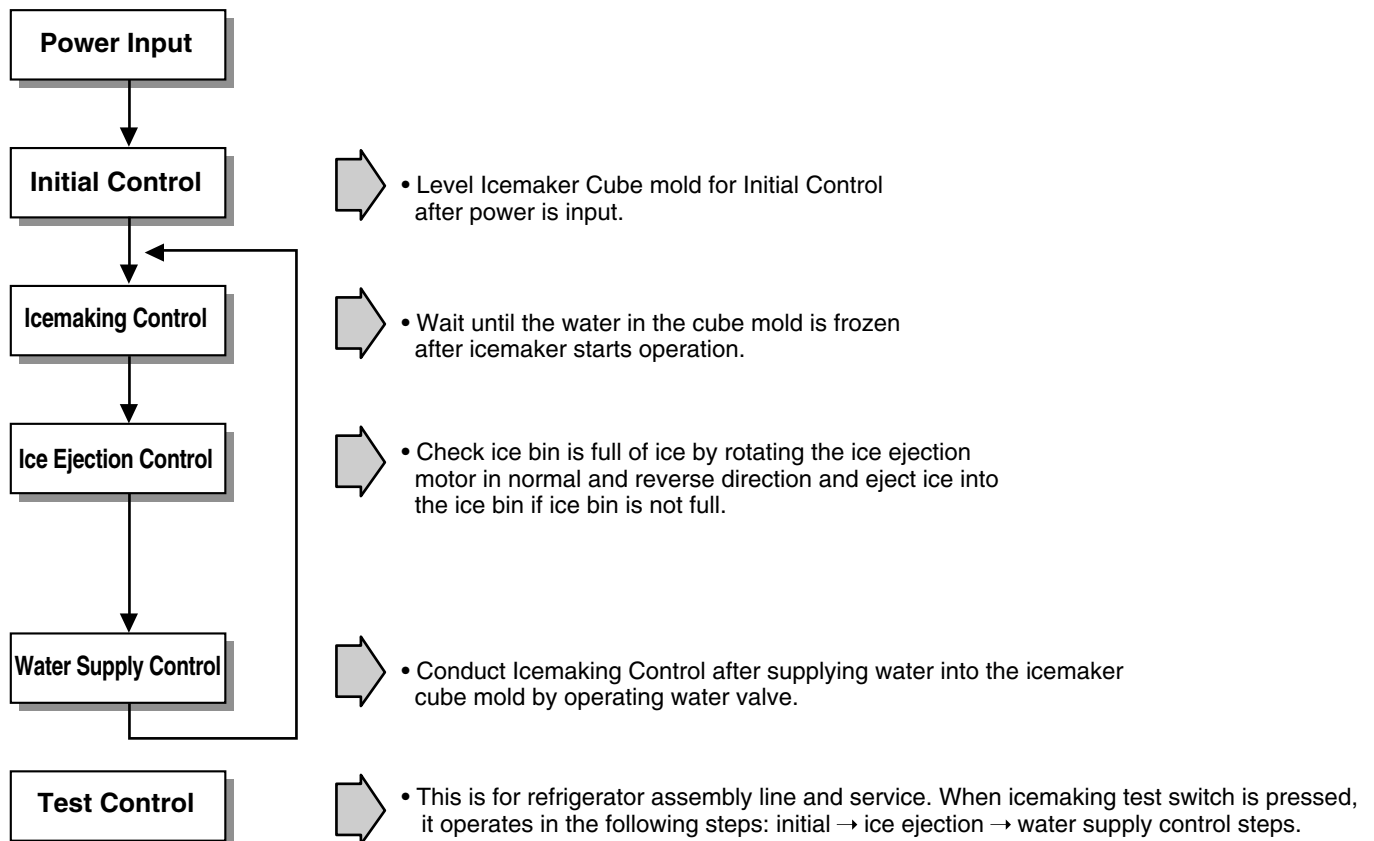

1-2. Dispenser Working Principles

1. This function is available in Model GR-L267BV(T)R, GR-L267BV(T)RA, GR-L267BV(T,S)PA (Refer to appendix) where water and ice are available without opening freezer compartment door.
2. **Crushed Ice** is automatically selected when power is initially applied or reapplied after power cut.
3. When dispenser selection switch is continuously pressed, light is on in the following sequence:
Water → Cube Ice → Crushed Ice.
4. Lamp is on when dispenser button is pressed and vice versa.
5. When dispenser crushed ice rubber button is pressed, dispenser solenoid and geared motor work so that crushed ice can be dispensed if there is ice in the ice bin.
6. If there is ice in the bin, pushing the dispenser button will dispense it.
7. When dispenser water button is pressed, water valve opens and water is supplied if water valve is normally installed on the right side of the machine room.
8. Ice and water are not available when freezer door is open.

ICEMAKER AND DISPENSER WORKING PRINCIPLES AND REPAIR

2. Function of Icemaker

2-1. Initial Control Function

1. When power is initially applied or reapplied after power cut, it detects level of icemaker cube mold after completion of MICOM initialization. The detecting lever moves up and down.
2. The level of ice maker cube mold is judged by output signal, high and low signal, of Hall IC. Make the cube mold to be horizontal by rotating ice ejection motor in normal or reverse direction so that High/Low signal can be applied to MICOM Pin No. 42.
3. If there is no change in signal one minute after the geared motor starts to operate, it stops icemaker operation and check the signal every hour. It resets initialization of icemaker when it becomes normal.
4. It judges that the initial control is completed when it judges the icemaker cube mold is horizontal.
5. Ice ejection conducts for 1 cycle regardless of ice in the ice bin when power is initially applied.

2-2. Water Supply Control Function

1. This is to supply water into the ice maker cube mold by operating water valve in the mechanical area when ice ejection control is completed and ice maker mould is even.
2. The quantity of water supplied is determined by DIP switch and time.

Water Supply Quantity Table

No	GR-L267BV(T)R (Refer to appendix)			GR-L267BV(T)RA, GR-L267BV(T,S)PA (Refer to appendix)				REMARKS
	DIP SWITCH SETTING		WATER SUPPLY TIME	DIP SWITCH SETTING			WATER SUPPLY TIME	
	S1	S2		S1	S2	S3		
1	OFF	OFF	6.5 SEC	OFF	OFF	OFF	6.5 SEC	* The quantity of water supplied depends on DIP switch setting conditions and water pressure as it is a direct tap water connection type. (the water supplied is generally 80 cc to 120 cc) * DIP switch is on the main PWB.
2	ON	OFF	5.5 SEC	ON	OFF	OFF	5.5 SEC	
3	OFF	ON	7.5 SEC	OFF	ON	OFF	6 SEC	
4	ON	ON	8.5 SEC	ON	ON	OFF	7 SEC	
5				OFF	OFF	ON	7.5 SEC	
6				ON	OFF	ON	8 SEC	
7				OFF	ON	ON	9 SEC	
8				ON	ON	ON	10 SEC	

3. If the water supply quantity setting is changed while the power is on, the change will take effect immediately. If it is changed while the icemaker is filling the mold, the new setting will take effect the next time the icemaker cycles.
4. When water supply signal is applied to water and ice valves at the same time during water supply, water shall be supplied to water valve. If water supply signal is applied to ice valve during water supply, water shall be supplied to both water and ice valves.

2-3. Icemaking Control Function

1. Icemaking control is carried out from the completion of water supply to the completion of ice making in the cube mold. Icemaking sensor detects the temperature of cube mold and completes ice making. (ice making sensor is fixed below icemaker cube mold)
2. Icemaking control starts after completion of water supply control or initial control.
3. The icemaker determined it's cycle is completed when the Icemaking sensor reaches -8 °C (17.6°F) after 100 minutes have passes since water filled the mold.
4. It is judged that icemaking is completed when ice maker sensor temperature reaches below -12 °C after 20 minutes in condition 3.

ICEMAKER AND DISPENSER WORKING PRINCIPLES AND REPAIR

2-4. Ice Ejection Control Function

1. This is to eject ice from ice maker cube mold after icemaking is completed.
2. If Hall IC signal is on within 3 6/10 seconds after ice ejection motor rotates in normal direction, it does not proceed ice ejection but waits. If the ice bank is full, ice ejection motor rotates in normal direction in every hour to check the condition of ice bank. If the ice bank is not full, the water supply control starts after completion of ice ejection control. If the ice bin is full, ice ejection motor rotates in reverse direction and stops under icemaking or waiting conditions.
3. If ice bin is not full, ice ejection starts. The cube mold tilts to the maximum and ice is separated from the mold and ice checking lever raises.
4. Ice ejection motor stops for 1 second if Hall IC signal changes from OFF (low) to ON (high) after 3 6/10 seconds when ice ejection motor rotates in normal direction. If there is no change in Hall IC signals within 1 minute after ice ejection motor operates, ice ejection motor stops as ice ejection motor or hall IC is out of order.
5. If ice ejection motor or Hall IC is abnormal, ice ejection motor rotates in normal direction to exercise initial operation. It resets the ice maker if ice ejection motor or Hall IC is normal.
6. The mold stops for 1 second at maximum tilted conditions.
7. The mold returns to horizontal conditions as ice ejection motor rotates in reverse direction.
8. When the mold becomes horizontal, the cycle starts to repeat:
Water Supply → Ice Making → Ice Ejection → Mold Returns to Horizontal

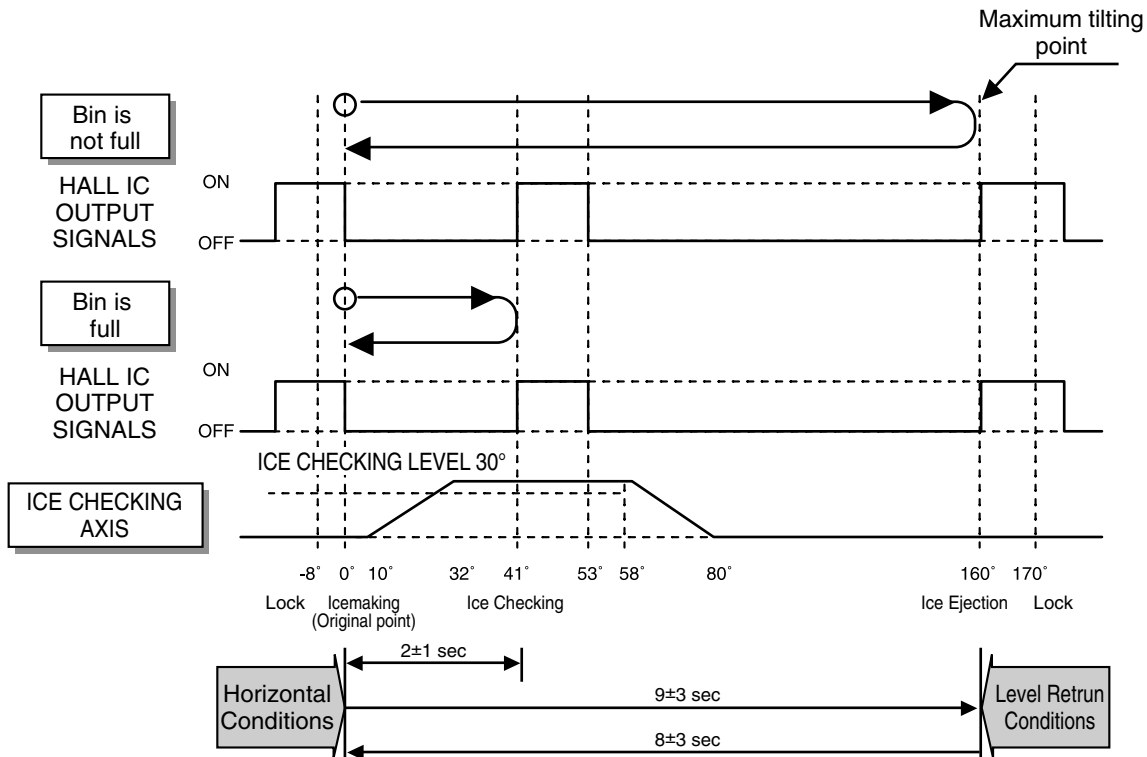

ICEMAKER AND DISPENSER WORKING PRINCIPLES AND REPAIR

2-5 Test Function

1. It is to force the operation during operation test, service, and cleaning. The test switch is mounted under the automatic icemaker. The test function starts when the test switch is pressed for more than 1/2 second.
2. Test button does not work during ice ejection and water supply. It works when it is in the horizontal conditions. If mold is full of ice during test function operation, ice ejection control and water supply control do not work.
3. If the mold is in the horizontal (normal) position and the TEST switch is pressed for more than 1/2 second, ice ejection will begin regardless of how frozen the water might be. When the ejection is completed, the icemaker will refill the mold with water. Consequently, problems related to filling, ejecting, and returning to the horizontal position can be checked using the test switch. When this test is performed, the buzzer will sound and water will fill the mold. Check the icemaker for repair if the buzzer does not sound.
4. When water supply is completed, the cycle operates normally as follows: Icemaking → Ice ejection → Returning to horizontal conditions → Water supply
5. Remove ice from the icemaker cube mold and press test switch when icemaker cube mold is full of ice as ice ejection and water supply control do not work when cube mold is full of ice.

2-6. Other functions relating to freezer compartment door opening

1. When freezer door is open, ice dispenser stops in order to reduce noise and ice drop.
2. When freezer door is open during ice ejection and cube mold returning to horizontal condition, ice ejection and cube mold level return proceed.
3. When freezer door is open, geared motor and cube ice solenoid immediately stop and duct door solenoid stops after 5 seconds.
4. Water dispenser stops in order to protect water drop when freezer door is open.
5. Test function operates normally regardless of refrigerator compartment door opening.

ICEMAKER AND DISPENSER WORKING PRINCIPLES AND REPAIR

3. Icemaker Troubleshooting

* **Troubleshooting:** it is possible to confirm by pressing freezer and refrigerator temperature control buttons for more than 1 second. (icemaker is normal if all LEDs are on); refer to trouble diagnosis function in MICOM function 2-8 (page 21)

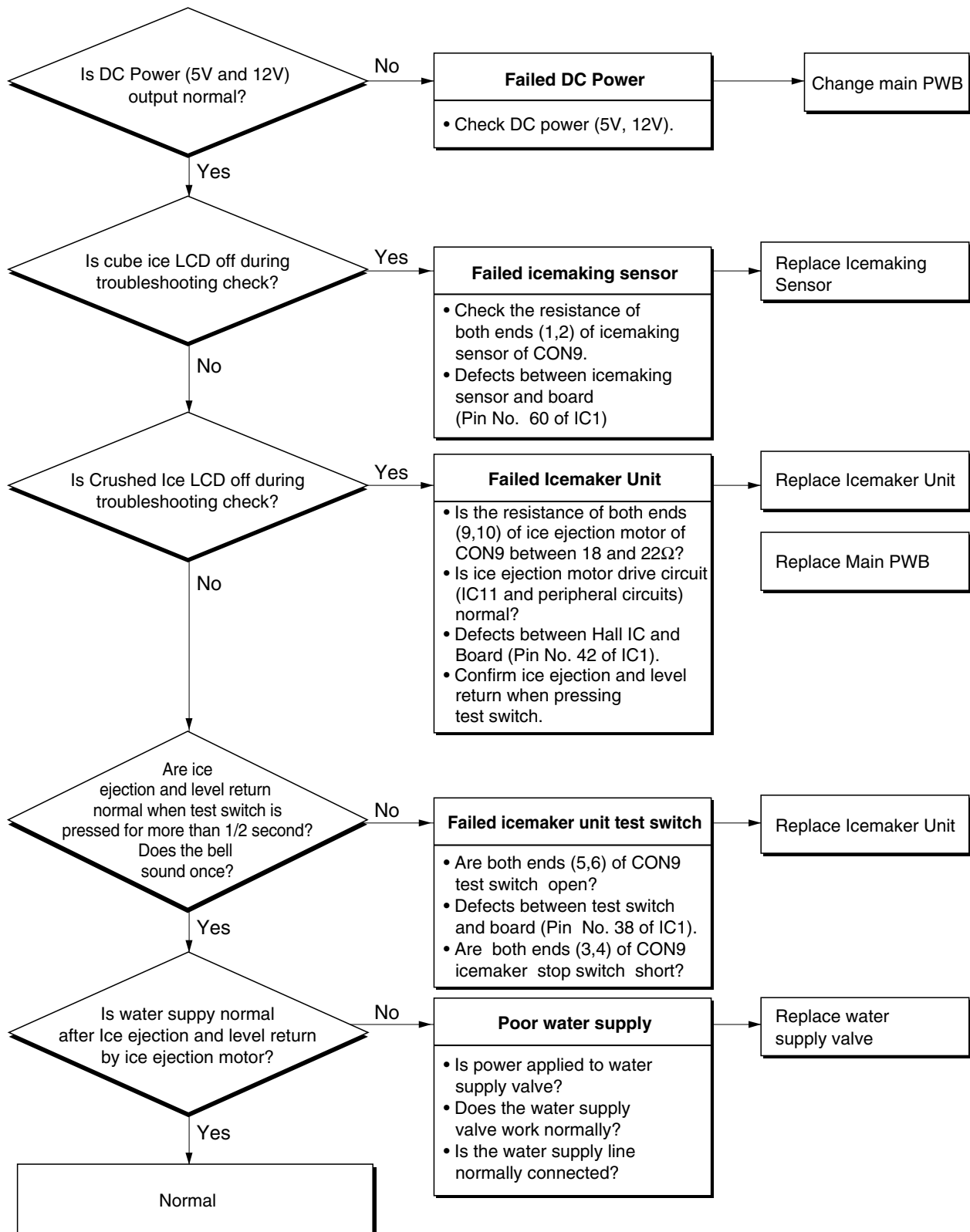

ICEMAKER AND DISPENSER WORKING PRINCIPLES AND REPAIR

4. Icemaker Circuits

(1) GR-L267BV(T)R, BNRY (Refer to appendix)

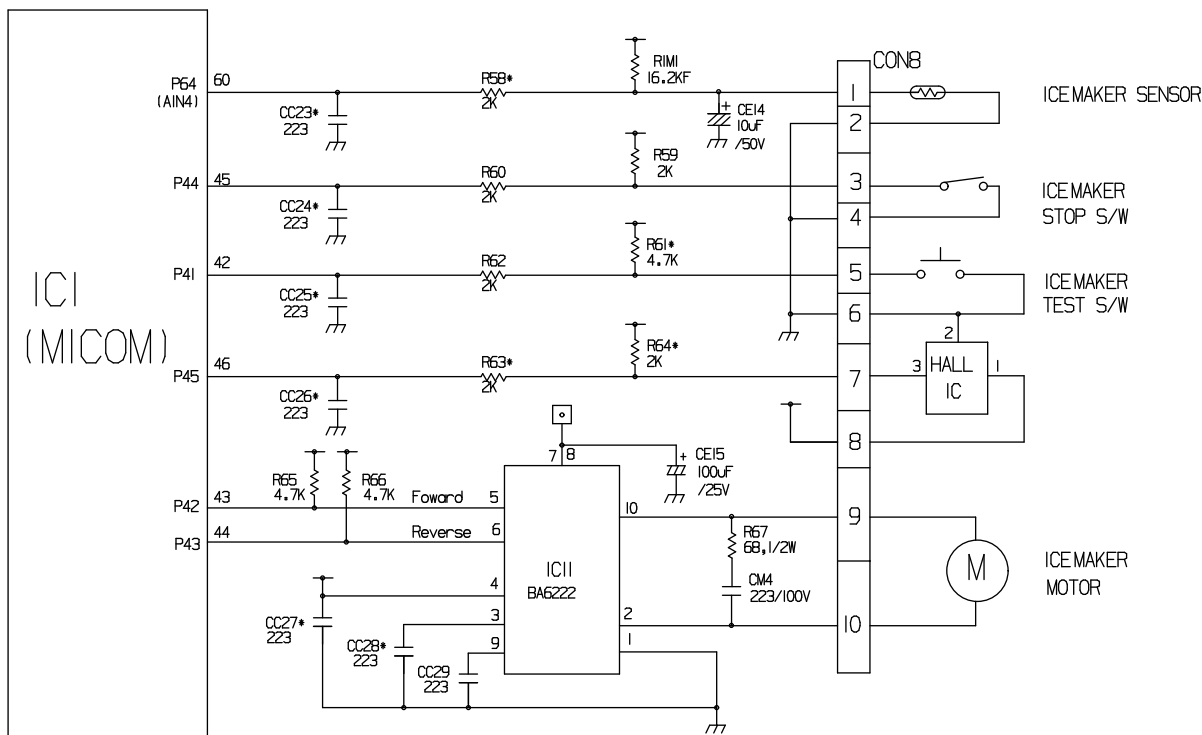

2) GR-L267BV(T)RA (Refer to appendix)

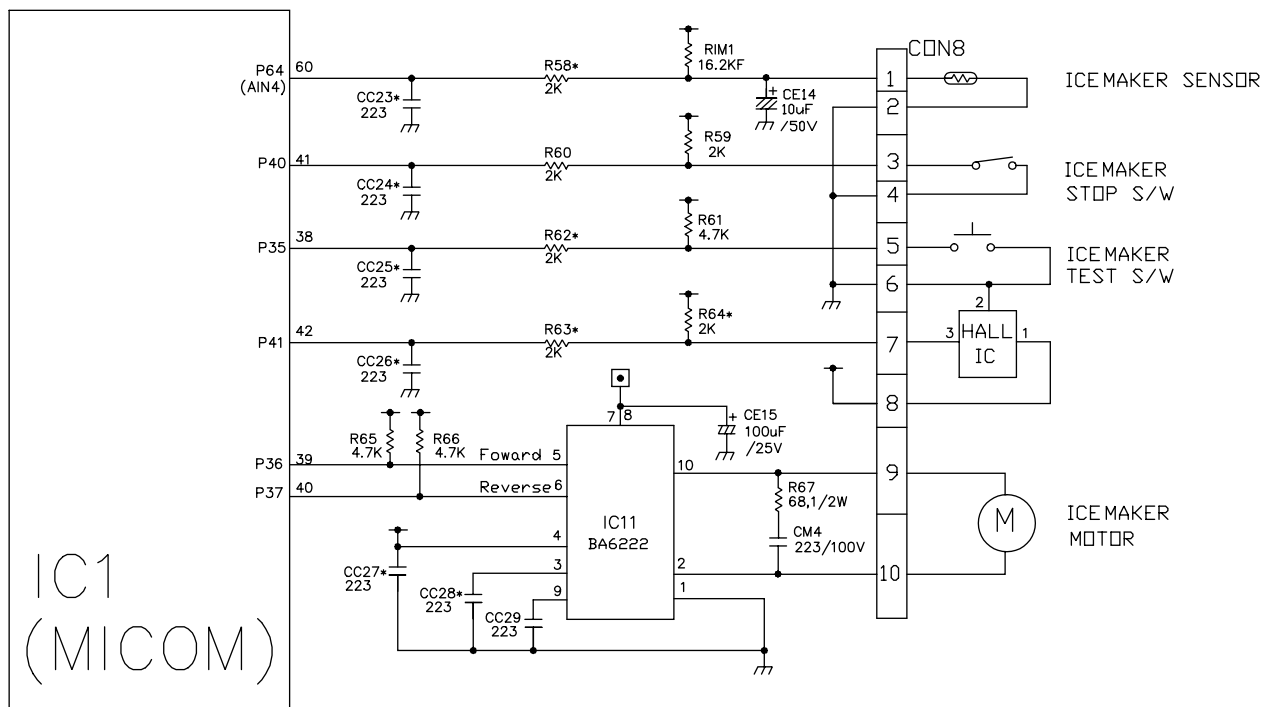

ICEMAKER AND DISPENSER WORKING PRINCIPLES AND REPAIR

(3) GR-L267BV(T,S)PA (Refer to appendix)

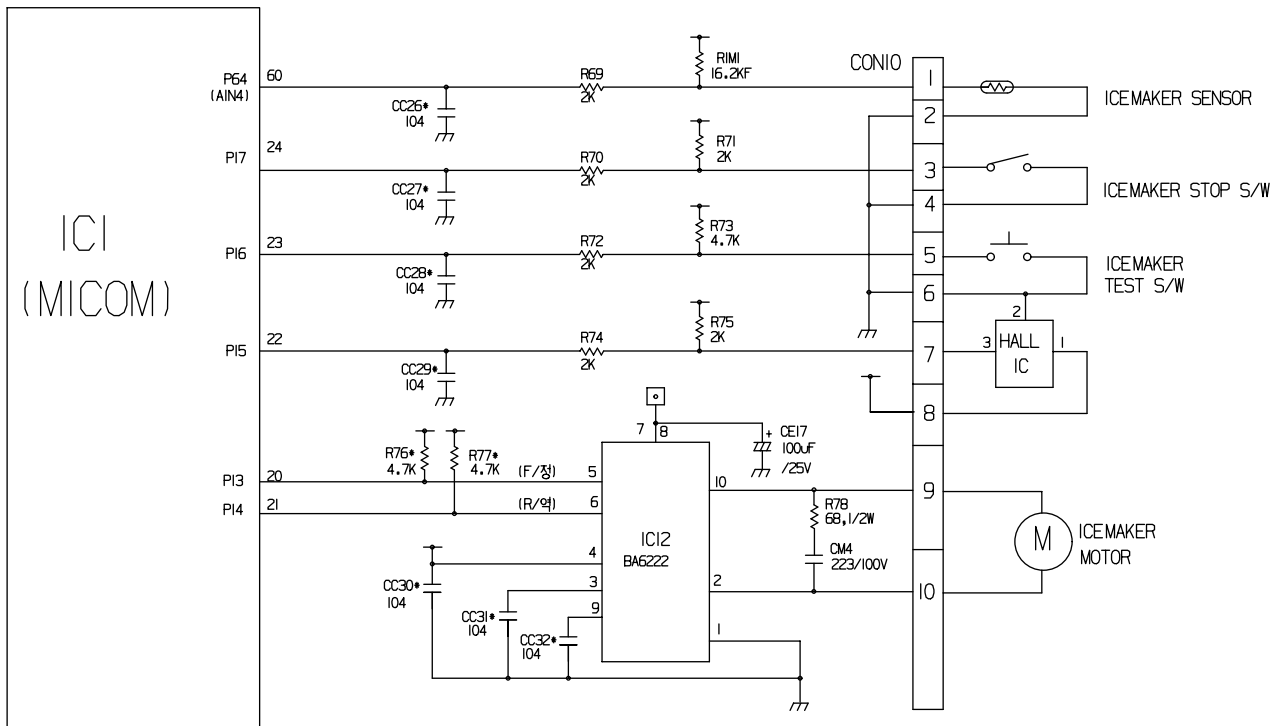

The above icemaker circuits are applied to GR-L267BV(T)R, GR-L267BV(T)RA, GR-L267BV(T,S)PA and composed of icemaker unit in the freezer and icemaker driving part of main PWB. Water is supplied to the icemaker cube mold through the solenoid relay for ice valve of solenoid valve in the mechanical area by opening valve for the set time. Water supply automatically stops when water supply time is elapsed. This circuit is to realize the functions such as ice ejection of icemaker cube mold, ice full detection, leveling, Ice making temperature detection, etc. Refer to the temperature detecting circuits of Main PWB for Ice making temperature detection. Icemaker test switch input detection is the same as the door switch input detection circuit of main PWB.

1. It is to force to operate during operation test, service, and cleaning. The test switch is mounted under the automatic icemaker. The test function starts when the test switch is pressed for more than 1/2 second.
2. Test button does not work during ice ejection and water supply. It works when it is in the horizontal conditions. If cube mold is full of ice during test function operation, ice ejection control and water supply control do not work.
3. Ice ejection carries out regardless of ice formation in the ice making tray if test switch is pressed for more than 1/2 second. Water will be splashed if test switch is pressed before the water in the mold is completely frozen. Water will be supplied while the mold returns to the horizontal conditions after ice ejection. Therefore, the problems of ice ejection, leveling, and water supply can be checked by test switch. When test function performs normally, buzzer sounds and water supply shall carry out. Check it for repair if buzzer does not sound.
4. When water supply is completed, normal cycle works: Icemaking → Ice Ejection → Level Return → Water Supply.
5. If icemaker stop switch is set to ON, normal cycle operates: Icemaking → Ice Ejection → Level Return → Water Supply. If is set to OFF, ice making conducts but ice ejection, level return, and water supply do not work.

CIRCUIT

(1) GR-L267BV(T)R (Refer to appendix)

CIRCUIT DIAGRAM

DELUXE

Several of the parts listed are subject to change according to the country in which the product is intended to be sold and may vary from model to model. Check the particular model number when ordering parts.
 - H/BAR PART (H/BAR HEATER, DOOR SW), CAPACITOR PART, PLUG TYPE, COMPRESSOR GROUND PART, PILOT VALVE, SW PART, OPTIC HILL ZONE, WATER-TANK SENSOR ON CIRCUIT DIAGRAMS ARE SUBJECT TO CHANGE IN DIFFERENT LOCALITIES AND ACCORDANCE WITH MODEL TYPE.

- N : NEUTRAL

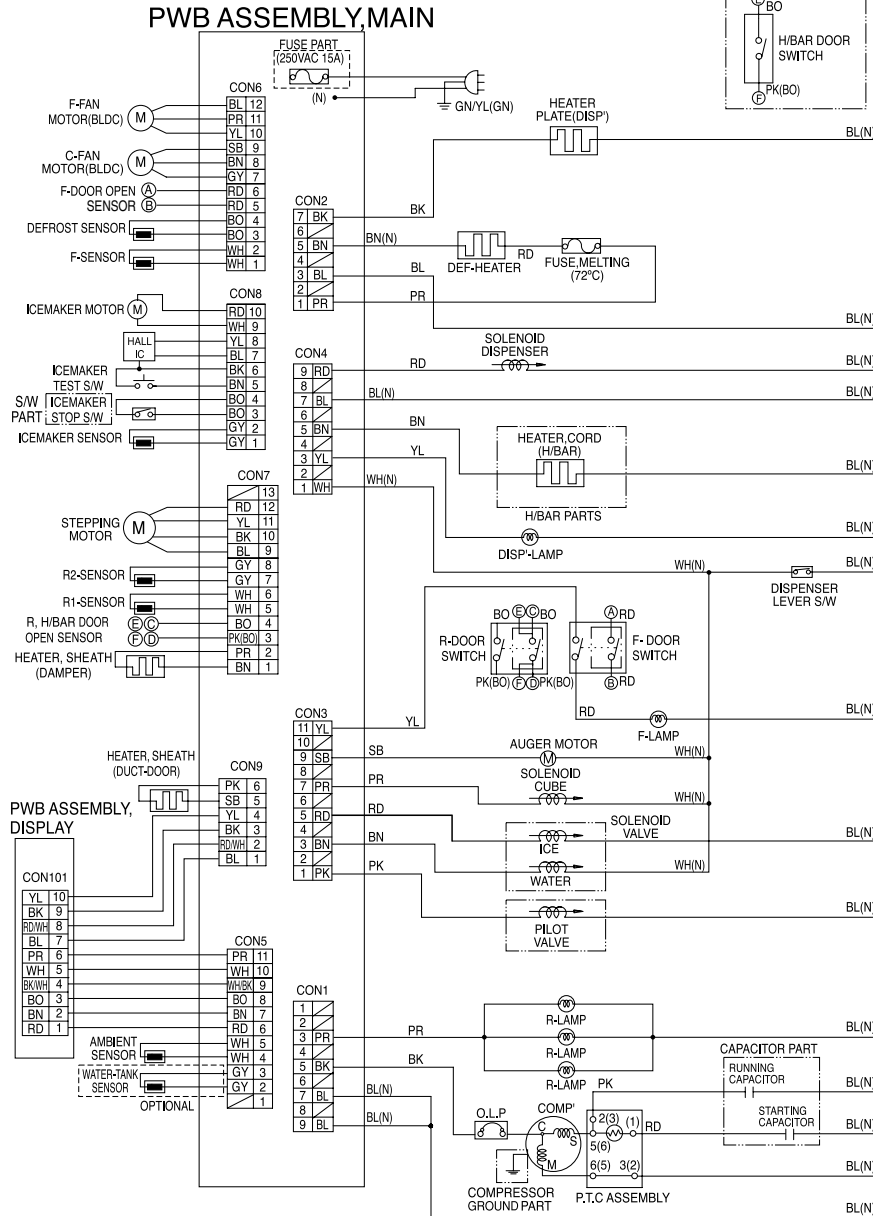

BK : BLACK	BN : BROWN	BO : BRIGHT ORANGE	GY : GRAY	RD : RED
YL : YELLOW	GN : GREEN	PR : PURPLE	WH : WHITE	WH/BK : WHITE/BLACK
SB : SKY BLUE	PK : PINK	GN/YN : GREEN/YELLOW	BL/WH : BLUE/WHITE	RD/WH : RED/WHITE

3854JD1125A

CIRCUIT

(2) GR-L267BNRY (Refer to appendix)

CIRCUIT DIAGRAM

DELUXE

- H/BAR PART(H/BAR HEATER,DOOR S/W),CAPACITOR PART, PLUG TYPE, COMPRESSOR EARTH PART, PILOT VALVE, S/W PART, OPTICILL ZONE,WATER-TANK SENSOR ON CIRCUIT DIAGRAMS ARE SUBJECT TO CHANGE IN DIFFERENT LOCALITES AND ACCORDANCE WITH MODEL TYPE.

- N : NEUTRAL

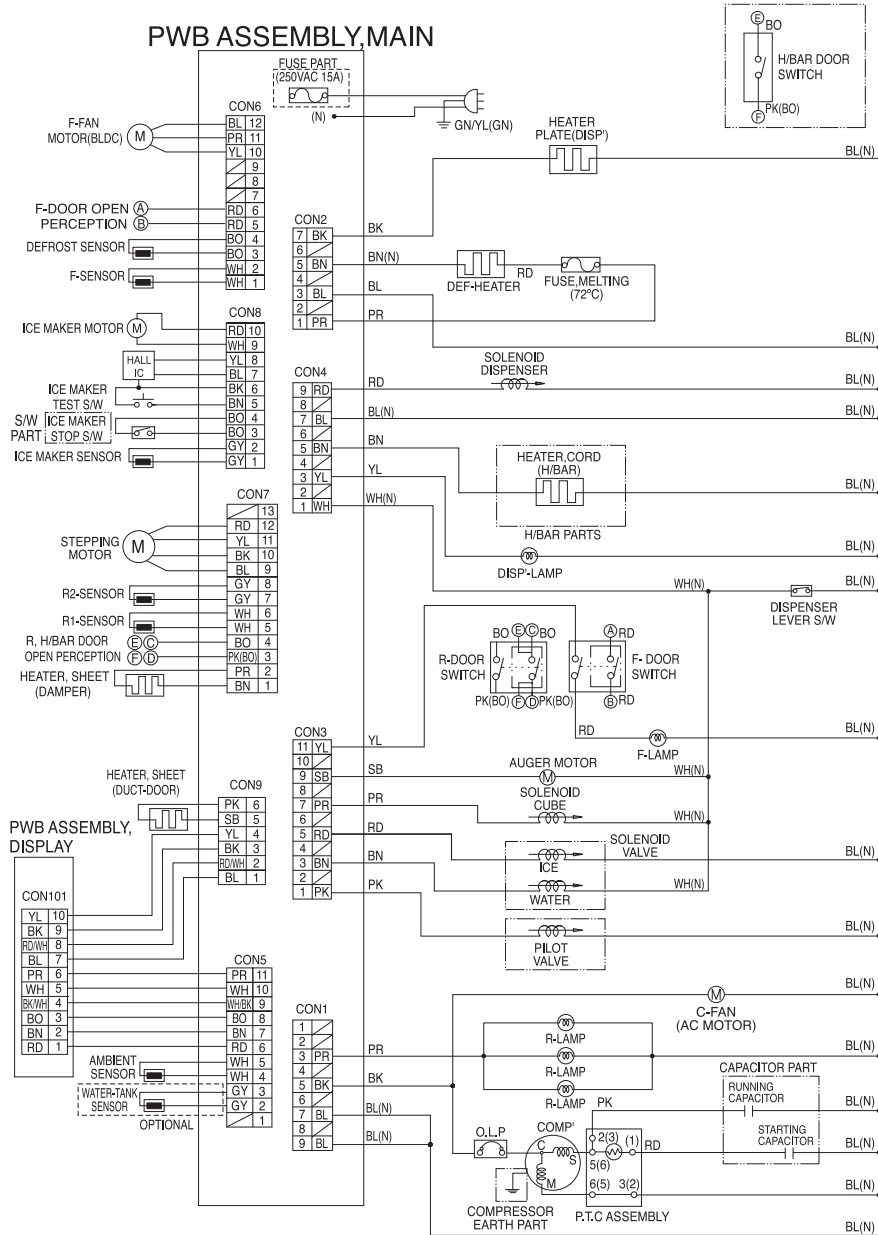

BK : BLACK
YL : YELLOW
SB : SKY BLUE

BN : BROWN
GN : GREEN
PK : PINK

BO : BRIGHT ORANGE
PR : PURPLE
GN/YN : GREEN/YELLOW

GY : GRAY
WH : WHITE
BL/WH : BLUE/WHITE

RD : RED
WH/BK : WHITE/BLACK
RD/WH : RED/WHITE

3854JD1140A

CIRCUIT

(3) GR-L267BV(T)RA (Refer to appendix)

CIRCUIT DIAGRAM

DELUXE

Several of the parts listed are subject to change according to the country in which the product is intended to be sold and may vary from model to model. Check the particular model number when ordering parts.
 - H/BAR PART(H/BAR HEATER,DOOR S/W),CAPACITOR PART, PLUG TYPE, COMPRESSOR GROUND PART,PILOT VALVE, S/W PART, OPTIC HILL ZONE, WATER-TANK SENSOR ON CIRCUIT DIAGRAMS ARE SUBJECT TO CHANGE IN DIFFERENT LOCALITES AND ACCORDANCE WITH MODEL TYPE.

- N : NEUTRAL

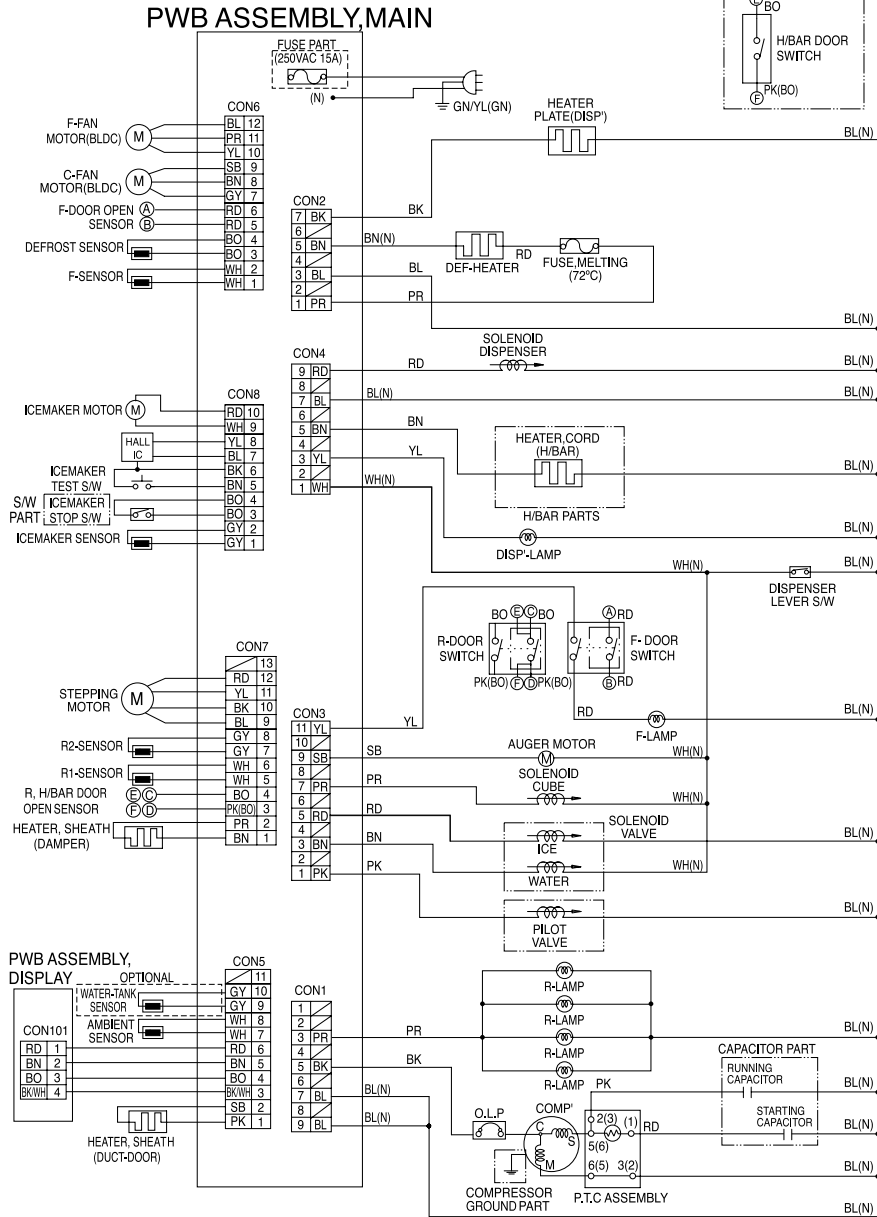

3854JD1125B

CIRCUIT

(4) GR-L267BV(T,S)PA (Refer to appendix)

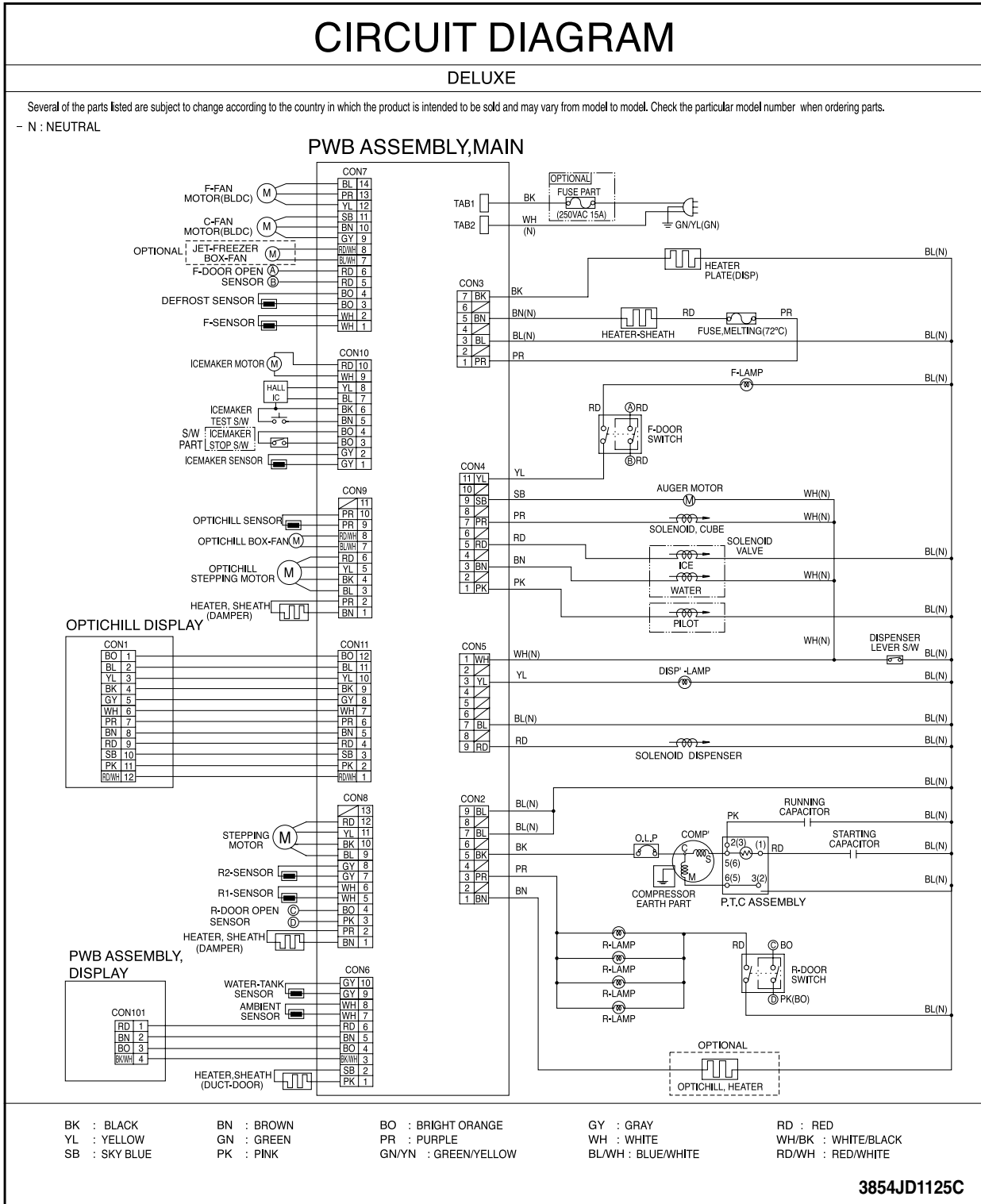

TROUBLE DIAGNOSIS

1. Troubleshooting

CLAIMS.	CAUSES AND CHECK POINTS.	HOW TO CHECK
<p>1. Faulty start</p>	<p>1) No power at outlet. 2) No power on cord.</p> <ul style="list-style-type: none"> - Bad connection between adapter and outlet. (faulty adapter) <ul style="list-style-type: none"> - The Inner diameter of adapter. - The distance between holes. - The distance between terminals. - The thickness of terminal. - Bad connection between plug and adapter (faulty plug). <ul style="list-style-type: none"> - The distance between pins. - Pin outer diameter. <p>3) Shorted start circuit.</p> <ul style="list-style-type: none"> - No power on power cord. <ul style="list-style-type: none"> - Disconnected copper wire. <ul style="list-style-type: none"> - Power cord is disconnected. - Faulty soldering. - Internal electrical short. - Faulty terminal contact. <ul style="list-style-type: none"> - Loose contact. <ul style="list-style-type: none"> - Large distance between male terminal. - Thin female terminal. - Terminal disconnected. - Bad sleeve assembly. - Disconnected. <ul style="list-style-type: none"> - Weak connection. - Short inserted cord length. - Worn out tool blade. - OLP is off. <ul style="list-style-type: none"> - Capacity of OLP is small. - Characteristics of OLP is bad. - Bad connection. - Power is disconnected. <ul style="list-style-type: none"> - Inner Ni-Cr wire blows out. - Bad internal connection. - Faulty terminal caulking (Cu wire is cut). - Bad soldering. - No electric power on compressor. - Faulty compressor. - Faulty PTC. <ul style="list-style-type: none"> - Power does not conduct. - Damage. - Bad characteristics. - Initial resistance is big. - Bad connection with compressor. <ul style="list-style-type: none"> - Too loose. - Assembly is not possible. - Bad terminal connection. <p>4) During defrost. <ul style="list-style-type: none"> - Start automatic defrost. - Cycle was set at defrost when the refrigerator was produced. </p>	<p>* Measuring instrument: Multi tester</p> <ul style="list-style-type: none"> ■ Check the voltage. If the voltage is within $\pm 85\%$ of the rated voltage, it is OK. ■ Check the terminal movement. ■ Check both terminals of power cord. Power conducts:OK. No power conducts:NG ■ Check both terminals of OLP If power conducts:OK. If not:NG. ■ Check the resistance of both terminals. At normal temperature 6: OK. If disconnected:∞.

TROUBLE DIAGNOSIS

CLAIMS.	CAUSES AND CHECK POINTS.	HOW TO CHECK
<p>2. No cooling.</p>	<p>2) Refrigeration system is clogged.</p> <ul style="list-style-type: none"> - Moisture clogged. <ul style="list-style-type: none"> - Residual moisture in the evaporator. <ul style="list-style-type: none"> - Air Blowing. <ul style="list-style-type: none"> - Not performed. - Too short. - Impossible moisture confirmation. - Low air pressure. - Leave it in the air. <ul style="list-style-type: none"> - During rest time. - After work. - Caps are missed. - Residual moisture. <ul style="list-style-type: none"> - Not dried in the compressor. - Elapsed more than 6 months after drying - Caps are missed. - No pressure when it is open. - No electric power on thermostat. <ul style="list-style-type: none"> - Insufficient drier capacity. <ul style="list-style-type: none"> - Dry drier - Drier temperature. - Leave it in the air. <ul style="list-style-type: none"> - Check on package condition. - Good storage after finishing. - Residual moisture in pipes. <ul style="list-style-type: none"> - Caps are missed. <ul style="list-style-type: none"> - During transportation. - During work. - Air blowing. <ul style="list-style-type: none"> - Not performed. - Performed. <ul style="list-style-type: none"> - Too short time. - Low air pressure. - Less dry air. - Moisture penetration - Leave it in the air. - Moisture penetration into the refrigeration oil. - Weld joint clogged. <ul style="list-style-type: none"> - Short pipe insert. - Pipe gaps. <ul style="list-style-type: none"> - Too large. - Damaged pipes. - Too much solder. - Drier clogging. <ul style="list-style-type: none"> - The capillary tube inserted depth. - Too much. - Capillary tube melts. - Over heat. - Clogged with foreign materials. <ul style="list-style-type: none"> - Desiccant powder. - Weld oxides. - Drier angle. - Reduced cross section by cutting. - Squeezed. - Foreign material clogging. <ul style="list-style-type: none"> - Compressor cap is disconnected. - Foreign materials are in the pipe. 	<ul style="list-style-type: none"> ■ Heat a clogged evaporator to check it. As soon as the cracking sound starts, the evaporator will begin to freeze. ■ The evaporator does not cool from the beginning (no evidence of moisture attached). The evaporator is the same as before even heat is applied.

TROUBLE DIAGNOSIS

CLAIMS.	CAUSES AND CHECK POINTS.	HOW TO CHECK
<p>3. Poor Cooling</p>	<p>1) Refrigerant Partly leaked. ┌ Weld joint leak. └ Parts leak.</p> <p>2) Poor defrosting capacity.</p> <p style="margin-left: 20px;">┌ Drain path (pipe) clogged. ┌ Inject adiabatics into drain hose. └ Foreign materials penetration. ┌ Adiabatics lump input. └ Damage by a screw or clamp. └ Other foreign materials input. └ Cap drain is not disconnected.</p> <p style="margin-left: 20px;">┌ Defrost heater does not generate heat. ┌ Parts disconnected. ┌ Plate heater ┌ Wire is cut. └ Heating wire. └ Contact point between heating and electric wire. └ Dent by fin evaporator. └ Poor terminal contacts. └ Cord heater ┌ Wire is cut. └ Lead wire. └ Heating wire. └ Contact point between heating and electric wire. └ Heating wire is corroded. └ Water penetration. └ Bad terminal connection.</p>	<p>■ Check visually.</p> <p>■ Check terminal Conduction: OK. No conduction: NG. If wire is not cut, refer to resistance. P=Power V=Voltage R=Resistance</p> $P = \frac{V^2}{R}$ $R = \frac{V^2}{P}$

TROUBLE DIAGNOSIS

CLAIMS.	CAUSES AND CHECK POINTS.	HOW TO CHECK
<p>3. Poor Cooling</p>	<ul style="list-style-type: none"> Residual frost. <ul style="list-style-type: none"> Weak heat from heater. - Sheath Heater - rated. Too short defrosting time. <ul style="list-style-type: none"> Defrost Sensor. <ul style="list-style-type: none"> - Faulty characteristics. Seat-D (missing, location, thickness). Structural fault. <ul style="list-style-type: none"> Gasket gap. Air inflow through the fan motor. Bad insulation of case door. No automatic defrosting. Defrost does not return. <p>3) Cooling air leak.</p> <ul style="list-style-type: none"> Bad gasket adhesion <ul style="list-style-type: none"> Gap. Bad attachment. Contraction. Door sag. <ul style="list-style-type: none"> Bad adhesion. Weak binding force at hinge. <p>4) No cooling air circulation.</p> <ul style="list-style-type: none"> Faulty fan motor. <ul style="list-style-type: none"> Fan motor. <ul style="list-style-type: none"> Self locked. Wire is cut. Bad terminal contact. Door switch. <ul style="list-style-type: none"> Faults. <ul style="list-style-type: none"> Contact distance. Button pressure. Melted contact. Contact. Refrigerator and freezer switch reversed. Button is not pressed. <ul style="list-style-type: none"> Poor door attachment. Door liner (dimension). Contraction inner liner. Misalignment. Bad terminal connection. Adiabatics liquid leak. 	<p>■ Check the fan motor conduction: OK. No conduction: NG.</p>

TROUBLE DIAGNOSIS

CLAIMS.	CAUSES AND CHECK POINTS.	HOW TO CHECK
<p>3. Poor Cooling</p>	<p>4) No cooling air circulation.</p> <ul style="list-style-type: none"> <ul style="list-style-type: none"> Faulty fan motor. — Fan is constrained. <ul style="list-style-type: none"> Fan shroud contact. - Clearance. Damping evaporator contact. Accumulated residual frost. Small cooling air discharge. <ul style="list-style-type: none"> Insufficient motor RPM <ul style="list-style-type: none"> Fan overload. - Fan misuse. Bad low temperature RPM characteristics. Rated power misuse. Low voltage. Faulty fan. <ul style="list-style-type: none"> Fan misuse. Bad shape. Loose connection. - Not tightly connected. Insert depth. Shroud. — Bent. Ice and foreign materials on rotating parts. 5) Compressor capacity. <ul style="list-style-type: none"> Rating misuse. Small capacity. Low voltage. 6) Refrigerant too much or too little. <ul style="list-style-type: none"> Malfunction of charging cylinder. Wrong setting of refrigerant. Insufficient compressor. - Faulty compressor. 7) Continuous operation <ul style="list-style-type: none"> - No contact of temperature controller. - Foreign materials. 8) Damper opens continuously. <ul style="list-style-type: none"> Foreign materials jammed. <ul style="list-style-type: none"> Adiabatics liquid dump The EPS (styrofoam®) drip tray has sediment in it. A screw or other foreign material has fallen into the drip tray or damper. Failed sensor. - Position of sensor. Characteristics of damper. <ul style="list-style-type: none"> Bad characteristics of its own temperatue. Parts misuse. Charge of temperature - Impact. characteristics. 9) Food storing place. - Near the outlet of cooling air. 	<ul style="list-style-type: none"> ■ Check visually after disassembly. ■ Check visually after disassembly.

TROUBLE DIAGNOSIS

CLAIMS.	CAUSES AND CHECK POINTS.	HOW TO CHECK
<p>4. Warm refrigerator compartment temperature.</p>	<p>1) Clogged cooling path.</p> <ul style="list-style-type: none"> └ Adiabatics liquid leak ?. └ Foreign materials. — Adiabatics dump liquid <p>2) Food storage.</p> <ul style="list-style-type: none"> └ Store hot food. └ Store too much at once. └ Door open. └ Packages block air flow. 	
<p>5. No automatic operation. (faulty contacts)</p>	<p>1) Faulty temperature sensor in freezer or refrigerator compartment.</p> <ul style="list-style-type: none"> └ Faulty contact. └ Faulty temperature characteristics. <p>2) Refrigeration load is too much.</p> <ul style="list-style-type: none"> └ Food. <ul style="list-style-type: none"> └ Too much food. └ Hot food. └ Frequent opening and closing. └ Cool air leak. └ Poor door close. — Partly opens. <p>3) Poor insulation.</p> <p>4) Bad radiation.</p> <ul style="list-style-type: none"> └ High ambient temperature. └ Insufficient space around refrigerator. <p>5) Refrigerant leak.</p> <p>6) Inadequate of refrigerant.</p> <p>7) Weak compressor discharging power.</p> <ul style="list-style-type: none"> └ Different rating. └ Small capacity. <p>8) Fan does not work.</p> <p>9) Button is set at strong.</p>	<p>■ Inspect parts measurements and check visually.</p>
<p>6. Condensation and ice formation.</p>	<p>1) Ice in freeezer compartment.</p> <ul style="list-style-type: none"> └ External air inflow. — Bushing installed incorrectly. └ Door opens but not closes. <ul style="list-style-type: none"> └ Weak door closing power. └ Stopper malfunction. └ Door sag. └ Food hinders door closing. └ Gap around gasket. — Contraction, distortion, loose, door twisted, corner not fully inserted. └ Food vapor. — Storing hot food. — Unsealed food. <p>2) Condensation in the refrigerator compartment.</p> <ul style="list-style-type: none"> └ Door opens but not closes. <ul style="list-style-type: none"> └ Insufficient closing. └ Door sag. └ Food hinders door closing. └ Gasket gap. <p>3) Condensation on liner foam.</p> <ul style="list-style-type: none"> └ Cool air leak and transmitted. <ul style="list-style-type: none"> └ Not fully filled. <ul style="list-style-type: none"> └ Top table part. └ Out plate Ref/Lower part. └ Flange gap. — Not sealed. └ Gasket gap. 	

TROUBLE DIAGNOSIS

CLAIMS.	CAUSES AND CHECK POINTS.	HOW TO CHECK
<p>6. Condensation and ice formation.</p>	<p>4) Condensation on door.</p> <ul style="list-style-type: none"> Condensation on the duct door. - Duct door heater is cut. Condensation on the dispense recess. <ul style="list-style-type: none"> Recess Heater is cut. Duct door is open. / Foreign material clogging. Condensation on the door surface. <ul style="list-style-type: none"> Not fully filled. <ul style="list-style-type: none"> Surface. } Liquid shortage. Corner. } Liquid leak. Adiabatics liquid contraction. Condensation on the gasket surface. <ul style="list-style-type: none"> Bad wing adhesion. <ul style="list-style-type: none"> Wing sag(lower part). Door liner shape mismatch. Corner. <ul style="list-style-type: none"> Too much notch. Broken. Home Bar heater is cut. <p>5) Water on the floor.</p> <ul style="list-style-type: none"> Condensation in the refrigerator compartment. Defrosted water overflows. — Clogged discharging hose. Discharging hose — Evaporation tray located at wrong place. location. Tray drip. <ul style="list-style-type: none"> Damaged. Breaks, holes. Small Capacity. Position of drain. 	
<p>7. Sounds</p>	<p>1) Compressor compartment operating sounds.</p> <ul style="list-style-type: none"> Compressor sound inserted. <ul style="list-style-type: none"> Sound from machine itself. Sound from vibration. <ul style="list-style-type: none"> Restrainer. Bushing seat. <ul style="list-style-type: none"> Too hard. Distorted. Aged. Burnt. Stopper.— Bad Stopper assembly. <ul style="list-style-type: none"> Not fit (inner diameter of stopper). Tilted. Not Compressor base not connected. Bad welding compressor stand(fallen). Foreign materials in the compressor compartment. OLP sound. — Chattering sound. Capacitor noise. — Insulation paper vibration. Pipe sound. <ul style="list-style-type: none"> Pipe contacts each other. — Narrow interval. No vibration damper. <ul style="list-style-type: none"> Damping Bushing-Q. Damping Bushing-S. Capillary tube unattached. 	

TROUBLE DIAGNOSIS

CLAIMS.	CAUSES AND CHECK POINTS.	HOW TO CHECK
7. Sounds	<p>1) Compressor compartment operating sounds.</p> <ul style="list-style-type: none"> Transformer sound. <ul style="list-style-type: none"> Its own fault. — Core gap. Bad connection. — Correct screw connection. Drip tray vibration sound. <ul style="list-style-type: none"> Bad assembly. Distortion. Foreign materials inside. Back cover machine sound. <ul style="list-style-type: none"> Bad connection. Partly damaged. Condenser drain sound. <ul style="list-style-type: none"> Not connected. Bad pipe caulking. <p>2) Freezer compartment sounds.</p> <ul style="list-style-type: none"> Fan motor sound. <ul style="list-style-type: none"> Normal operating sound. Vibration sound. <ul style="list-style-type: none"> Aged rubber seat. Bad torque for assembling motor bracket. Sounds from fan contact. <ul style="list-style-type: none"> Fan guide contact. Shroud burr contact. Damping evaporator contact. Residual frost contact. <ul style="list-style-type: none"> Damaged heater cord. Narrow evaporator interval. Unbalance fan sounds. <ul style="list-style-type: none"> Unbalance. <ul style="list-style-type: none"> Surface machining conditions. Fan distortion. Misshappen. Burr. Ice on the fan. — Air intake (opposite to motor bushing assembly) Motor shaft contact sounds. <ul style="list-style-type: none"> Supporter disorted. Tilted during motor assembly. Resonance. Evaporator noise. <ul style="list-style-type: none"> Evaporator pipe contact. — No damping evaporator. Sound from refrigerant. — Stainless steel pipe shape in accumulator. Sound from fin evaporator and pipe during expansion and contraction. <p>3) Bowls and bottles make contact on top shelf.</p> <p>4) Refrigerator roof contact.</p> <p>5) Refrigerator side contact.</p> <p>6) Insufficient lubricants on door hinge.</p>	

TROUBLE DIAGNOSIS

CLAIMS.	CAUSES AND CHECK POINTS.	HOW TO CHECK
<p>8. Faulty lamp (freezer and refrigerator compartment).</p>	<p>1) Lamp problem. — Filament blows out. — Glass is broken.</p> <p>2) Bad lamp assembly. — Not inserted. — Loosened by vibration.</p> <p>3) Bad lamp socket.</p> <ul style="list-style-type: none"> — Disconnection. — Bad soldering. — Bad rivet contact. — Short. — Water penetration. — Low water level in tray. — Bad elasticity of contact. — Bad contact (corrosion). <p>4) Door switch. — Defective. — Refrigerator and freezer switches are reversed. — Travel distance. — Bad connection. — Bad terminal contact. — Adiabatics liquid leak..</p>	
<p>9. Faulty internal voltage (short).</p>	<p>1) Lead wire is damaged.</p> <ul style="list-style-type: none"> — Wire damage when assembling PTC Cover. — Outlet burr in the bottom plate. — Pressed by cord heater. lead wire, evaporator pipe. <p>2) Exposed terminal.</p> <ul style="list-style-type: none"> — Compressor Compartment terminal. - Touching other components. — Freezer compartment terminal. - Touching evaporator pipe. <p>3) Faulty parts.</p> <ul style="list-style-type: none"> — Transformer. — Coil contacts cover. — Welded terminal parts contact cover. — Compressor. — Bad coil insulation. — Plate heater. — Melting fuse. — Sealing is broken. — Moisture penetration. — Cord heater. — Pipe damaged. — Moisture penetration. — Bad sealing. — Sheath heater. 	<p>■ Connect conduction and non-conduction parts and check with tester. Conduction: NG. Resistance∞: OK.</p>

TROUBLE DIAGNOSIS

CLAIMS.	CAUSES AND CHECK POINTS.	HOW TO CHECK
<p>10. Structure, appearance, and others.</p>	<p>1) Door foam.</p> <ul style="list-style-type: none"> Sag. <ul style="list-style-type: none"> Hinge loose <ul style="list-style-type: none"> Bolt is loosened during transportation. Not tightly fastened. Screw worn out . Weak gasket adhesion. <ul style="list-style-type: none"> Adhesion surface. Fixed tape. <ul style="list-style-type: none"> Not well fixed. Noise during operation. <ul style="list-style-type: none"> Hinge interference. <ul style="list-style-type: none"> Bigger door foam. Hinge-Pin tilted-Poor flatness. No washer. No grease. Malfunction. <ul style="list-style-type: none"> Not closed Interference between door liner and inner liner. Refrigerator compartment is opened when freezer compartment is closed (faulty stopper). <ul style="list-style-type: none"> Stopper worn out. Bad freezer compartment door assembly. No stopper. <p>2) Odor.</p> <ul style="list-style-type: none"> Temperature of refrigerator compartment. <ul style="list-style-type: none"> High. <ul style="list-style-type: none"> Faulty damper control. Button is set at weak. Door is open (interference by food). Deodorizer. <ul style="list-style-type: none"> No deodorizer. Poor capacity. Food Storage. <ul style="list-style-type: none"> Seal condition. Storage of fragrant foods. Long term storage. Others. <ul style="list-style-type: none"> Odors from cleaners or items which shroud not be stored in a refrigerator. 	

TROUBLE DIAGNOSIS

2. Faults

2-1. Power

Problems	Causes	Checks	Measures	Remarks
No power on outlet.	<ul style="list-style-type: none"> - Power cord cut. - Faulty connector insertion. - Faulty connection between plug and adapter. 	<ul style="list-style-type: none"> - Check the voltage with tester. - Check visually. - Check visually. 	<ul style="list-style-type: none"> - Replace the components. - Reconnect the connecting parts. - Reconnect the connecting parts. 	
Fuse blows out.	<ul style="list-style-type: none"> - Short circuit by wrong connection. - Low voltage products are connected to high voltage. - Short circuit by insects. - Electricity leakage. - High voltage. - Short circuit of components (tracking due to moisture and dust penetration). 	<ul style="list-style-type: none"> - Check the fuse with tester or visually. - Check the input volt are with tester (between power cord and products). - Check the resistance of power cord with tester (if it is 0Ω, it is shorted). 	<ul style="list-style-type: none"> - Find and remove the cause of problem (ex. short, high voltage, low voltage). - Replace with rated fuse. 	<ul style="list-style-type: none"> - Replace with rated fuse after confirming its specification. ■ If fuse blows out frequently, confirm the cause and prevent.

2-2. Compressor

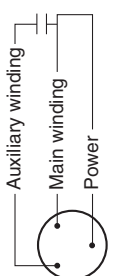
Problems	Causes	Checks	Measures	Remarks
Compressor does not operate.	<ul style="list-style-type: none"> - Faulty PTC. - Compressor is frozen. 	<ul style="list-style-type: none"> - Check the resistance. Value:∞ is defective. - If compressor assembly parts are normal (capacitor, PTC, OLP), apply power directly to the compressor to force operation. 	<ul style="list-style-type: none"> - If resistance is infinite, replace it with new one. - If it is not infinite, it is normal. - Check other parts. - During forced operation: - Operates: Check other parts. - Not operate: Replace the frozen compressor with new one, weld, evacuate, and recharge refrigerant. 	
		<p>OLP</p>  <p>It starts as soon as it is contacted.</p>	<ul style="list-style-type: none"> • Refer to weld repair procedures. 	

TROUBLE DIAGNOSIS

2-3. Temperature

Problems	Causes	Checks	Measures	Remarks
High temperature in the freezer compartment.	Poor cool air circulation due to faulty fan motor.	<ul style="list-style-type: none"> - Lock — Check resistance with a tester. 0Ω: short. ∞Ω: cut. - Rotate rotor manually and check rotation. - Wire is cut. - Bad terminal contact: Check terminal visually. - Fan constraint. — Fan shroud contact: Confirm visually. — Fan icing: Confirm visually. 	<ul style="list-style-type: none"> - Replace fan motor. - Reconnect and reinsert. - Maintain clearance and remove ice (Repair and/or replace shroud if fan is constrained by shroud deformation). 	
	Faulty fan motor due to faulty door switch operation.	<ul style="list-style-type: none"> - Iced button (faulty) operation: Press button to check - Faulty button pressure and contact: Press button to check operation. - Door cannot press door switch button: Check visually. 	<ul style="list-style-type: none"> - Confirm icing causes and repair. - Replace door switch. - Door sag: fix door. - Door liner bent: replace door or attach sheets. 	
	Bad radiation conditions in compressor compartment.	<ul style="list-style-type: none"> - Check the clearance between the refrigerator and wall (50 mm in minimum). - Check dust on the grill in compressor compartment. - Check dust on the condenser coils. 	<ul style="list-style-type: none"> - Keep clearance between refrigerator and walls (minimum 50mm). - Remove dust and contaminants from grill for easy heat radiation. - Remove the dust with vacuum cleaner from the coils condenser while the refrigerator is off. 	<ul style="list-style-type: none"> - The fan may be broken of damaged if cleaned while the refrigerator is running.

TROUBLE DIAGNOSIS

2-4. Cooling

Problems	Causes	Checks	Measures	Remarks
High temperature in the freezer compartment.	Refrigerant leak.	<p><u>Check sequence</u></p> <ol style="list-style-type: none"> 1. Check the welded parts of the drier inlet and outlet and drier auxiliary in the compressor compartment (high pressure side). 2. Check the end of compressor sealing pipe (low pressure side). 3. Check silver soldered parts. 4. Check bending area of wire condenser pipe in compressor compartment (cracks can happen during bending). 5. Check other parts (compressor compartment and evaporators in freezer compartment). 	Weld the leaking part, recharge the refrigerant.	Drier must be replaced.
	Shortage of refrigerant.	<p>Check frost formation on the surface of evaporator in the freezer compartment.</p> <ul style="list-style-type: none"> - If the frost forms evenly on the surface, it is OK. - If it does not, it is not good. 	<ul style="list-style-type: none"> - Find out the leaking area, repair, evacuate, and recharge the refrigerant. - No leaking, remove the remaining refrigerant, and recharge new refrigerant. 	Drier must be replaced.

TROUBLE DIAGNOSIS

Problems	Causes	Checks	Measures	Remarks
High temperature in the freezer compartment.	Cycle pipe is clogged.	<p>Check sequence.</p> <ol style="list-style-type: none"> 1. Check temperature of condenser manually. If it is warm, OK. If it is not, compressor discharging joints might be clogged. 2. Manually check whether hot line pipe is warm. If it is warm, OK. If it is not, condenser outlet weld joints might be clogged. 	<ul style="list-style-type: none"> - Heat up compressor discharging weld joints with touch, disconnect the pipes, and check the clogging. <p>Remove the causes of clogging, weld, evacuate, and recharge the refrigerant.</p> <ul style="list-style-type: none"> - If it's warm, OK. If it's not, condenser discharging line weld joints might be clogged. <p>Disconnect with torch, remove the causes, evacuate, and recharge seal refrigerant.</p>	Drier must be replaced.
	Leak at loop pipe weld joint (discharge) in compressor.	<p>Check sequence.</p> <ol style="list-style-type: none"> 1. Manually check whether condenser is warm, it is not warm and the frost forms partly on the evaporator in the freezer compartment. 	<p>Replace the compressor, weld, evacuate, and recharge refrigerant.</p>	Drier must be replaced.
	Faulty cooling fan in the compressor compartment.	<p>Check sequence.</p> <ol style="list-style-type: none"> 1. Check cooling fan operation. 2. Check that cooling fan is disconnected from the motor. 	<ul style="list-style-type: none"> - Replace if motor does not operate. - If fan is disconnected, check fan damage and reassemble it. <p>■ Refer to fan motor disassembly and assembly sequence.</p>	

TROUBLE DIAGNOSIS

2-5. Defrosting failure

Problems	Causes	Checks	Measures	Remarks
No defrosting.	<p>Heater does not generate heat as the heating wire is cut or the circuit is shorted.</p> <p>1) Heating wire is damaged when inserting into the evaporator.</p> <p>2) Lead wire of heater is cut.</p> <p>3) Heating wire at lead wire contacts is cut.</p>	<p>1. Check the resistance of heater. 0Ω: Short. ∞Ω: Cut. Tens to thousands Ω: OK.</p> <p>2. Check the resistance between housing terminal and heater surface. 0Ω: Short. ∞Ω: Cut. Tens to thousands Ω: Short.</p>	<p>Heating wire is short and wire is cut.</p> <ul style="list-style-type: none"> Parts replacement: Refer to parts explanations. 	<p>Seal the lead wire with insulation tape and heat shrink tube if the cut lead wire is accessible to repair.</p>
Suction tube and discharge orifice:	<p>1. Impurities.</p> <p>2. Ice.</p>	<p>1. Confirm foreign materials. In case of ice, insert the copper line through the hole to check.</p> <p>2. Put hot water into the drain (check drains outside).</p>	<p>1) Push out impurities by inserting copper wire. (Turn off more than 3 hours and pour in hot water if frost is severe.)</p> <p>2) Put in hot water to melt down frost.</p> <p>3) Check the water outlet.</p> <p>4) Push the heater plate to suction duct manually and assemble the disconnected parts.</p>	
Gap between Suction duct and Heater plate (Ice in the gap).		<p>1. Confirm in the Suction duct.</p>	<p>1) Turn off the power, confirm impurities and ice in the gap, and supply hot water until the ice in the gap melts down.</p> <p>2) Push the Heater plate to drain bottom with hand and assemble the disconnected parts.</p>	
Wrong heater rating (or wrong assembly).		<p>1. Check heater label.</p> <p>2. Confirm the capacity after substituting the resistance value into the formula.</p> $P = \frac{V^2}{R}$ <p>(V: Rated voltage of user country) (R: Resistance of tester[Ω])</p> <p>Compare P and label capacity. Tolerance: ±7%</p>	<p>Faults: Replace.</p> <p>- How to replace : Refer to main parts.</p>	

TROUBLE DIAGNOSIS

Problems	Causes	Checks	Measures	Remarks
No defrosting	<p>Melting fuse blows.</p> <p>1) Lead wire is cut.</p> <p>2) Bad soldering.</p> <p>Ice in the Suction duct.</p> <p>1) Icing by foreign materials in the duct.</p> <p>2) Icing by cool air inflow through the gap of heater plate.</p> <p>3) Icing by the gap of heater plate.</p>	<p>- Check melting fuse with tester. - If 0Ω: OK. If ∞Ω: wire is cut.</p> <p>1. Check the inner duct with mirror.</p> <p>2. Check by inserting soft copper wire into the duct (soft and thin copper not to impair heating wire).</p>	<p>Faulty parts: parts replacement.</p> <p>- Check wire color when measuring resistance with a tester.</p> <p>1) Turn power off.</p> <p>2) Raise the front side (door side), support the front side legs, and let the ice melt naturally. (If power is on, melt the frost by forced defrosting.)</p> <p>3) Reassemble the heater plate.</p>	
	<p>Bad cool air inflow and discharge, and bad defrosting due to faulty contact and insertion (bad connector insertion into housing of heater, melting, fuse, and motor fan).</p>	<p>1. Turn on power, open or close the door, check that motor fan operates (If it operates, motor fan is OK).</p> <p>2. Disconnect parts in the refrigerator compartment, check the connection around the housing visually, defrost, and confirm heat generation on the heater. Do not put hands on the sheath heater.</p> <p>3. Check the parts which have faults described in 1 & 2 (mechanical model: disconnect thermostat from the assembly).</p>	<p>1) Check the faulty connector of housing and reassemble wrongly assembled parts.</p> <p>2) If the parts are damaged, remove the parts and replace it with a new one.</p>	

TROUBLE DIAGNOSIS

2-6. Icing

Problems	Causes	Checks	Measures	Remarks
Icing in the refrigerator compartment. - Damper icing. - Pipe icing. - Discharging pipe icing.	1) Bad circulation of cool air. - Clogged intake port in the refrigerator compartment. - Sealing is not good. - Too much food is stored and clogs the discharge port. - Bad defrosting.	- Check the food is stored properly (check discharge and intake port are clogged). - Check icing on the surface of baffle and cool air path (pipe) after dissembling the container box. - Check icing at intake ports of freezer and refrigerator compartment.	- Be acquainted with how to use. - Sealing on connecting parts. - Check the damper and replace it if it has defects. - Check defrost. (After forced defrosting, check ice in the evaporator and pipes.)	- Check the defrost related parts if problem is caused by faulty defrosting.
	2) Faulty door or refrigerator compartment. - Faulty gasket. - Faulty assembly.	- Check gasket attached conditions. - Check door assembly conditions.	- Correct the gasket attachment conditions and replace it. - Door assembly and replacement.	- Replacement should be done when it cannot be repaired.
	3) Overcooling in the refrigerator compartment. - Faulty damper in the refrigerator compartment. - Faulty MICOM (faulty sensor)	- Check refrigerator compartment is overcooled (when button pressed on weak). - Check parts are faulty.	- Replace faulty parts.	
	4) Bad defrosting - Heater wire is cut. - Defective defrost sensor. - Defrosting cycle.	- Check frost on the evaporator after dissembling shroud and fan grille. - Check ice on intake port of freezer and refrigerator compartment.	- Check parts related to defrosting. - Check defrosting. (Check ice on the evaporator and pipe.)	- Moisture does not freeze on the evaporator but can be sucked into the refrigerator, where it condenses and freezes. This interferes with cold air circulation and sublimation of the ice.
	5) Customers are not familiar with this machine. - Door opens. - High temperature, high moisture, and high load.	- Check food interferes with door closing. - Check ice on the ceilings.	- Be acquainted with how to use.	

TROUBLE DIAGNOSIS

Problems	Causes	Checks	Measures	Remarks
Ice in the freezer compartment. - Surface of fan grille. - Wall of freezer compartment. - Cool air discharging port. - Basket(rack) area.	1) Bad cooling air circulation. - Intake port is clogged in the freezer compartment. - Discharging port is Clogged. - Too much food is stored. - Bad defrosting.	- Check food storage conditions visually.(Check clogging at intake and discharging port of cooling air.) - Check food occupation ratio in volume (Less than 75%). - Check frost on the evaporator after dissembling shroud and fan grille. - Check icing at intake port of refrigerator compartment.	- Be acquainted with how to use. - Check defrost (Check ice on the evaporator and pipes after forced defrosting).	- Check the parts related to defrosting if the problem is caused by the faulty defrosting.
- Food surface. - Icing in the shute.	2) Bad freezer compartment door - Faulty gasket - Faulty assembly	- Check gasket attachment conditions. - Check door assembly conditions.	- Correct the gasket attachment conditions and replace it. - Door assembly and replacement.	- Replace when it can not be repaired.
	3) Over freezing in the freezer compartment. - Faulty MICOM.	- Refrigerator operates pull down. (Check if it is operated intermittently) - The Temperature of freezer compartment is satisfactory, but over freezing happens in the refrigerator compartment even though the notch is set at weak .	-Replace defective parts.	
	4) Bad defrosting. - Heater wire is cut. - Faulty defrost sensor. - Defrosting cycle	- Check frost on the evaporator after dissembling shroud and grille. - Check ice on the intake port in the refrigerator compartment.	- Check parts related to defrosting. - Check defrosting. Check ice on the evaporator and pipes after forced defrosting.	
	5) User is not familiar with how to use. - Door opens. - High moisture food water is stored.	- Check food holds door open. - Check ice on the ice tray.	- Be acquainted with how to use.	

TROUBLE DIAGNOSIS

2-7. Sound

Problems	Causes	Checks	Measures	Remarks
Hiss sound	1. Loud sound of compressor operation.	1.1 Check the level of the refrigerator. 1.2 Check the bushing seat conditions (sagging and aging).	1) Maintain horizontal level. 2) Replace bushing and seat if they are sagged and aged. 3) Touch the piping at various place along its route. Install a damper at the point where your touch reduces the noise. 4) Avoid pipe interference. 5) Replace defective fan and fan motor. 6) Adjust fan to be in the center of the fan guide. 7) Leave a clearance between interfering parts and seal gaps in the structures. 8) Reassemble the parts which make sound. 9) Leave a clearance if evaporator pipes and suction pipe touch freezer shroud.	
	2. Pipes resonate sound which is connected to the compressor.	2.1 Check the level of pipes connected to the compressor and their interference. 2.2 Check bushing inserting conditions in pipes. 2.3 Touch pipes with hands or screw -driver (check the change of sound).		
	3. Fan operation sound in the freezer compartment.	3.1 Check fan insertion depth and blade damage. 3.2 Check the interference with structures. 3.3 Check fan motor. 3.4 Check fan motor bushing insertion and aging conditions.		
	4. Fan operation sound in the compressor compartment.	4.1 Same as fan confirmation in the refrigerator. 4.2 Check drip tray leg insertion. 4.3 Check the screw fastening conditions at condenser and drip tray.		

TROUBLE DIAGNOSIS

Problems	Causes	Checks	Measures	Remarks
<p>Vibration sound. Clack.</p>	<ol style="list-style-type: none"> 1. Vibration of shelves and foods in the refrigerator. 2. Pipes interference and capillary tube touching in the compressor compartment. 3. Compressor stopper vibration. 4. Moving wheel vibration. 5. Other structure and parts vibration. 	<ol style="list-style-type: none"> 1-1. Remove and replace the shelves in the refrigerator 1-2. Check light food and container on the shelves. 2-1. Touch pipes in the compressor compartment with hands. 2-2. Check capillary tube touches cover back. 3-1. Check compressor stopper vibration. 4-1. Check vibration of front and rear moving wheels. 5-1. Touch other structures and parts. 	<ol style="list-style-type: none"> 1) Reassemble the vibrating parts and insert foam or cushion where vibration is severe. 2) Leave a clearance where parts interfere with each other. 3) Reduce vibration with bushing and restrainer if it is severe. (especially compressor and pipe). 4) Replace compressor stopper if it vibrates severely. 	
<p>Irregular sound. Click.</p>	<ol style="list-style-type: none"> 1. It is caused by heat expansion and contraction of evaporator, shelves, and pipes in the refrigerator. 	<ol style="list-style-type: none"> 1-1 Check time and place of sound sources. 	<ol style="list-style-type: none"> 1) Explain the principles of refrigeration and that the temperature difference between operation and defrosting can make sounds. 2) If evaporator pipe contacts with other structures, leave a clearance between them (freezer shroud or inner case). 	

TROUBLE DIAGNOSIS

Problems	Causes	Checks	Measures	Remarks
Sound Popping (almost the same as animal's crying sound).	It happens when refrigerant expands at the end of capillary tube.	<ul style="list-style-type: none"> - Check the sound of refrigerant at the initial installation. - Check the sound when the refrigerator starts operation after forced defrosting. - Check the restrainer attachment conditions on the evaporator and capillary tube weld joints. 	<ul style="list-style-type: none"> - Check the restrainer attached on the evaporator and capillary tube weld joints and attach another restrainer. - If it is continuous and severe, insert capillary tube again (depth 15±3mm) - Fasten the capillary tube to suction pipes or detach in the compressor compartment. - Explain the principles of freezing cycles. 	
Water boiling or flowing sound.	It happens when refrigerant passes orifice in accumulator internal pipes by the pressure difference between condenser and evaporator.	<ul style="list-style-type: none"> - Check the sound when compressor is turned on. - Check the sound when compressor is turned off. 	<ul style="list-style-type: none"> - Explain the principles of freezing cycles and refrigerant flowing phenomenon by internal pressure difference. - If sound is severe, wrap the accumulator with foam and restrainer. 	
Sound of whistle when door closes.	When door closes, the internal pressure of the refrigerator decreases sharply below atmosphere and sucks air into the refrigerator, making the whistle sound.	<ul style="list-style-type: none"> - Check the sound by opening and closing the refrigerator or freezer doors. 	<ul style="list-style-type: none"> - Broaden the cap of discharge hose for defrosting in the compressor compartment. - Seal the gap with sealant between out and inner cases of hinge in door. 	

TROUBLE DIAGNOSIS

2-8. Odor

Problems	Causes	Checks	Measures	Remarks
Food Odor.	Food (garlic, kimchi, etc)	<ul style="list-style-type: none"> - Check the food is not wrapped. - Check the shelves or inner wall are stained with food juice. - Be sure food is securely covered with plastic wrap. - Check food cleanliness. 	<ul style="list-style-type: none"> - Dry the deodorizer in a sunny place with adequate ventilation. - Store the food in the closed container instead of vinyl wraps. - Clean the refrigerator and set button at strong. 	
Plastic Odor.	Odors of mixed food and plastic odors.	<ul style="list-style-type: none"> - Check wet food is wrapped with plastic bowl and bag. - It happens in the new refrigerator. 	<ul style="list-style-type: none"> - Clean the refrigerator. - Persuade customers not to use plastic bag or wraps with wet food or odorous foods. 	
Odor from the deodorizer.	Odor from the old deodorizer.	<ul style="list-style-type: none"> - Check the deodorizer odors. 	<ul style="list-style-type: none"> - Dry the deodorizer with dryer and then in the shiny and windy place. - Remove and replace the deodorants. 	*Deodorizer : option

TROUBLE DIAGNOSIS

2-9. MICOM

Problems	Symptom	Causes		Checks	Measures	Remarks	
Bad PCB electric power.	All display LCD are off.	Bad connection between Main PCB and display circuit.	Bad connector connection from main PCB to display PCB.	Visual check on connector connection.	Reconnect connector.		
		Defective PCB transformer.	PCB transformer winding is cut. PCB transformer temperature fuse is burnt out.	Check resistance of PCB transformer input and output terminals with a tester. (If resistance is infinity, trans winding is cut).	Replace PCB transformer or PCB.	Applicable to model without dispenser.	
Abnormal display LCD operation	Defective LCD.	Defective PCB electric circuit parts.	Defective regulator IC (7812, 7805).	Check voltage at input/output terminals.	Replace regulator.	Refer to electric circuit in circuit explanation.	
			PCB electric terminal fuse is burned out.	Check fuse in PCB electric terminal with a tester.	Replace PCB fuse.		
			STR Parts are damaged.	Check if STR No. 2 and 3 pins are cut when power is off.	Replace parts.	Applicable to model with dispenser.	
		Bad connection between Main PCB and display circuit.	Lead Wire connecting main PCB and display PCB is cut or connector terminal connection is bad.	Check Lead Wire terminals connecting Main PCB and display PCB with a tester.	Reconnect Lead Wire and directly connect defective contact terminal to Lead Wire.		
			Defective LCD.	Check if all LCD are on when Main PCB Test switch is pressed (or when both freezer key and power freezer key are pressed at the same time for more than one second.)	Replace display PCB.	Refer to display circuit in circuit explanation.	

TROUBLE DIAGNOSIS

Problems	Symptom	Causes		Checks	Measures	Remarks	
Bad cooling.	Freezer temperature is high.	Compressor does not start.	Compressor Lead Wire is cut.	Check compressor Lead Wire with a tester.	Reconnect Lead Wire.		
			Defective compressor driving relay.	Measure voltage at PCB CON2 (3&9) after pressing main PCB test switch once. It is OK if voltage is normal.	Replace relay RY1 and RY2 or PCB.	Refer to load driving circuit in circuit explanation.	
		Defective freezer sensor.	Defective Freezer sensor parts.	Check resistance of freezer sensor with a tester.	Replace freezer sensor.	Refer to resistance characteristics table of sensor in circuit. Refer to tables on pages 39~42	
			The wrong sensor has been installed. Order by model number and part number.	Confirm the color of sensor in circuits (main PCB sensor housing).	Repair main PCB sensor housing	explanation.	
		Defective freezer fan motor.	Fan motor lead wire is cut.	Check fan motor lead wire with a tester.	Reconnect lead wire.		
			<ul style="list-style-type: none"> Defective door switch (freezer, refrigerator, home bar). Defective fan motor. Defective fan motor driving relay. 	Measure the voltage between PCB power blue line and fan motor after pressing test switch of Main PCB. If the voltage is normal, it is OK.	<ul style="list-style-type: none"> Replace door switch (freezer, refrigerator, and home bar). Replace fan motor. Replace relay RY5 & RY6 or PCB. 	Refer to load driving circuits in circuit explanation.	
	Faulty defrost.		Refer to faulty defrost items in trouble diagnosis functions.		Refer to trouble diagnosis function.		

TROUBLE DIAGNOSIS

Problems	Symptom	Causes	Checks	Measures	Remarks		
Bad cooling	Wrong Refrigerator temperature.	Defective Step Motor Damper.	Check Step Motor damper motor and reed switch and lead wire are cut. Check Step Motor damper part.	Check if Step Motor damper motor and reed switch lead wire are cut with a tester.	Reconnect lead wire.		
			Check Step Motor damper Motor driving relay in PCB.	Refer to Step Motor damper in parts repair guide.	Replace Step Motor damper or refrigerator control box Assembly.		
		Foreign materials in Step Motor damper baffles.	Ice formation on Step Motor damper baffles.	Check Step Motor damper baffle visually.	Remove foreign materials.		
			Defective refrigerator sensor parts.	Check the resistance of refrigerator sensor with a tester.	Replace refrigerator sensor.	Refer to single motor damper driving circuits in circuit explanation.	
		Defective refrigerator sensor	Refrigerator sensor is substituted for other sensor.	Check the sensor color in the circuit. (main PCB sensor housing.)	Repair main PCB sensor housing.		
			Defective refrigerator sensor assembly condition.	Check if refrigerator sensor is not fixed at cover sensor but inner case visually.	Fix again the refrigerator sensor.		

TROUBLE DIAGNOSIS

Problems	Symptom	Causes	Checks	Measures	Remarks
Bad defrost.	Defrost is not working.	Defrost lead wire is cut.	Check if defrost lead wire is cut with a tester.	Reconnect Lead Wire.	
		Defective defrost driving relay.	Check the voltage of CON2 (1 and 7) with a tester after pressing main PCB test switch twice. If the voltage is normal then it is OK.	Replace relay (RY 7 and RY 3) or PCB.	Refer to load driving conditions check in circuit explanation.
		Defective defrost sensor parts.	Check the resistance of defrost sensor with a tester.	Replace defrost sensor.	Refer to sensor resistance characteristic table of circuit explanation.
Defective buzzer	Buzzer continuously rings or door opening alarm does not work.	Defective connecting lead wire from main PCB to door switch.	Check lead wire related to door switch with a tester.	Repair lead wire.	
		Defective door switch parts.	Refer to door switch in parts repair guide.	Replace door switch.	
Defective display button	Buzzer does not sound and buttons do not operate.	Key input wire is cut or bad connector terminal contact in main PCB and display PCB connecting lead wire.	Check input wire with a tester.	Reconnect lead wire and replace or directly connect bad contact terminal to lead wire.	Refer to display circuit in circuit explanation.
		Key is continuously depressed due to structural interference.	Disassemble frame display and confirm visually.	Adjust or replace interfering structures.	

TROUBLE DIAGNOSIS

Problems	Symptom	Causes	Checks	Measures	Remarks
Defective display button.	Buzzer does not sound and buttons do not operate.	Trouble mode indication.	Check trouble diagnosis function.	Repair troubles	Refer to mode indication in function explanations.
Door Buzzer	Buzzer continuously rings or door opening alarm does not work.	Defective connecting lead wire from main PCB to door switch.	Check lead wire associated with door switch.	Repair lead wire.	Check model with dispenser.
		Defective freezer compartment door switch parts.	Refer to door switch in parts repair guide.	Replace Freezer compartment door switch.	
Bad water/ice dispenser.	Ice and water are not dispensed.	Defective connecting lead wire from Main PCB to lever switch.	Check Lead Wire associated with lever switch with a tester.	Repair lead wire.	
		Defective lever switch parts	Refer to door switch in parts repair guide.	Replace lever switch.	
		Defective photo coupler IC parts.	Check voltage change at photo coupler output terminals with lever switch pressed. It is OK if voltage change is between 0V - 5V.	Replace photo coupler IC or PCB.	
		Defective relay associated with ice dispenser (gearing motor, cube, and dispenser solenoid).	Check relay (RY4, RY5, RY12) with a tester.	Replace defective relay.	
		Defective parts associated with ice dispenser (gearing motor, cube, and dispenser solenoid).	Check resistance of parts with a tester.	Replace defective parts.	
		Defective relay associated with water dispenser.	Check relay (RY7) with a tester	Replace defective relay.	
		Defective parts associated with water dispenser.	Check resistance of parts with a tester.	Replace defective parts.	

TROUBLE DIAGNOSIS









3. Sealed System Heavy Repair

3-1. The Heavy Repair Standards for Refrigerator with R134a Refrigerant

NO.	Items	Unit	Standards	Purposes	Remarks	
1	Pipe and piping system opening time.	Min.	Pipe:within 1 hour. Comp:within 10 minutes. Drier:within 20 minutes.	To protect Moisture Penetration.	The opening time should be reduced to a half of the standards during rain and rainy seasons (the penetration of water into the pipe is dangerous).	
2	Welding.	Nitrogen Pressure.	Weld under Nitrogen atmosphere (N ₂ pressure: 0.1~0.2 kg/cm ²)	To protect oxide scale formation.	- Refer to repair note in each part. - R134a refrigerant is more susceptible to leaks than R12 and requires more care during welding. - Do not apply force to pipes before and after welding to protect pipe from cracking.	
3	N ₂ sealed parts.	Confirm N ₂ leak.	Confirm air leaking sounds when removing bushing cap. Sound: usable No sound: not usable	To protect moisture penetration.	- In case of evaporator parts, if it doesn't make noise when removing bushing cap blow dry air or N ₂ gas for more than 1 min use the parts.	
4	Refrigeration Cycle.	Evacuation time	Min.	More than 40 minutes.	To remove moisture.	Note:Only applicable to the model equipped with reverse flow protect plate. Vaccum efficiency can be improved by operating compressor during evacuation. The bushing pipes for R12 refrigerant shall be melted when they are used for R134a refrigerant causes of leak.
		Vacuum degree	Torr	Below 0.5 (ref)		
		Vacuum	EA	High and low Pressure sides are evacuated at the same time for models above 200ℓ		
		Vacuum piping	EA	Use R134a exclusive manifold.	To protect mixing of mineral and ester oils.	
		Pipe coupler	EA	Use R134a cxclusive.	To protect R12 Refrigerant mixing.	
		Outlet (Socket) Plug		R134a exclusive. R134a exclusive		
5	Refrigerant weighing.	EA	Use R134a exclusively. Weighing allowance:±5g Note:Winter:-5g Summer:+5g	Do not mix with R12 refrigerant.	- Do not weigh the refrigerant at too hot or too cold an area. (25°C[77°F] is adequate.) - Use copper charging canister Socket: 2SV Plug: 2PV R134a Note : Do not burn O-ring (rubber) during welding.	
6	Drier replacement.		-Use R134a exclusively for R134a refrigerator -Replace drier whenever repairing refrigerator cycle piping.	To remove the moisture from pipe.		
7	Leak check.		-Do not use soapy water for check. It may be sucked into the pipe.	Detect refrigerant leak area.	-Check oil leak at refrigerant leak area. Use electronic leak detector if oil leak is not found. -The electronic leak detector is very sensitive to halogen gas in the air. It also can detect R141b in urethane. Please practice therefore many times before use.	

TROUBLE DIAGNOSIS

3-2. Summary Of Heavy Repair

Process	Contents	Tools
		
	- Cut charging pipe ends and discharge refrigerant from drier and compressor.	Filter, side cutters
	- Use R134a oil and refrigerant for compressor and drier - Confirm N ₂ sealing and packing conditions before use. Use good one for welding and assembly. - Weld under nitrogen gas atmosphere. (N ₂ gas pressure: 1.42-2.85 psi). - Repair in a clean and dry place.	Pipe Cutter, Gas welder, N ₂ gas
	- Evacuate for more than forty minutes after connecting manifold gauge hose and vacuum pump to high (drier) and low (compressor refrigerant discharging parts) pressure sides. - Evacuation Speed: 113 liters/minute.	Vacuum pump R134a exclusively, Manifold gauge.
	- Weigh and control the allowance of R134a charging canister in a vacuum conditions to be ± 0.176 oz with electronic scales and charge through compressor inlet (Charge while compressor operates). - Weld carefully after pinching off the inlet pipe.	R134a exclusive charging canister (mass cylinder), refrigerant R134a manifold gauge, electronic scales, pinch-off plier, gas welding machine
	- Check leak at weld joints. <input type="checkbox"/> Minute leak : Use electronic leak detector <input type="checkbox"/> Big leak : Check visually. Note: Do not use soapy water for check. - Check cooling capacity ① Check radiator manually to see if warm. ② Check hot line pipe manually to see if warm. ③ Check frost formation on the whole surface of the evaporator. NOTE: Some tools should be reserved for use with R134a exclusively. Tools and gauges used with R134a should be kept clean and stored separately from other tools to avoid cross- contamination by other refrigerants and lubricants.	Electronic Leak Detector, Driver (Ruler).
	- Remove flux from the silver weld joints with soft brush or wet rag. Flux may be the cause of corrosion and leaks. - Clean R134a exclusive tools and store them in a clean tool box or in their place.	Copper brush, Rag, Tool box
	- Installation should be conducted in accordance with the standard installation procedure. Leave space of more than 5 cm (2 inches) from the wall for compressor compartment cooling fan mounted model.	

TROUBLE DIAGNOSIS

3-3. Precautions During Heavy Repair

Items	Precautions
1. Use of tools.	1) Use special parts and tools for R134a.
2. Recovery of refrigerant.	<p>1) Continue to recover the refrigerant for more than 5 minutes after turning the refrigerator off.</p> <p>2) Install a piercing type valve on the high pressure line (drier side). Then use the appropriate recovery equipment to recover the refrigerant from the system. When the refrigerant has been recovered, install a piercing type valve on the low pressure side. IT IS IMPORTANT TO OPEN THE SYSTEM IN THIS ORDER TO KEEP THE OIL FROM BEING FORCED OUT.</p> <p>The use of piercing type valves will allow future servicing and eliminates the possibility of a defective pinch off.</p> <div data-bbox="602 736 1265 1023" data-label="Diagram"> <p>The diagram illustrates a refrigeration cycle. On the left, a circular compressor is connected to a coil-shaped condenser. A line labeled 'Hot Line' connects the condenser to a drier, which is represented as a small rectangular box with a zigzag line inside. To the right of the drier is the evaporator, shown as a rectangular box with an 'X' inside. The line returns from the evaporator to the compressor. A circled '2' is placed near the low pressure side of the compressor, and a circled '1' is placed near the high pressure side of the drier.</p> </div>
3. Replacement of drier.	1) Be sure to replace drier with R134a only when repairing pipes and injecting refrigerant.
4. Nitrogen blowing welding.	<p>1) Use pressurized nitrogen to prevent oxidation inside the piping.</p> <p>(Nitrogen pressure : 1.42 - 2.85 psi)</p>
5. Others.	<p>1) Only nitrogen or R134a should be used when cleaning the inside of piping of the sealed system.</p> <p>2) Check leakage with an electronic leakage tester.</p> <p>3) Be sure to use a pipe cutter when cutting pipes.</p> <p>4) Be careful not the water let intrude into the inside of the cycle.</p>

TROUBLE DIAGNOSIS









3. Sealed System Heavy Repair

3-1. The Heavy Repair Standards for Refrigerator with R134a Refrigerant

NO.	Items	Unit	Standards	Purposes	Remarks	
1	Pipe and piping system opening time.	Min.	Pipe:within 1 hour. Comp:within 10 minutes. Drier:within 20 minutes.	To protect Moisture Penetration.	The opening time should be reduced to a half of the standards during rain and rainy seasons (the penetration of water into the pipe is dangerous).	
2	Welding.	Nitrogen Pressure.	Weld under Nitrogen atmosphere (N ₂ pressure: 0.1~0.2 kg/cm ²)	To protect oxide scale formation.	- Refer to repair note in each part. - R134a refrigerant is more susceptible to leaks than R12 and requires more care during welding. - Do not apply force to pipes before and after welding to protect pipe from cracking.	
3	N ₂ sealed parts.	Confirm N ₂ leak.	Confirm air leaking sounds when removing bushing cap. Sound: usable No sound: not usable	To protect moisture penetration.	- In case of evaporator parts, if it doesn't make noise when removing bushing cap blow dry air or N ₂ gas for more than 1 min use the parts.	
4	Refrigeration Cycle.	Evacuation time	Min.	More than 40 minutes.	To remove moisture.	Note:Only applicable to the model equipped with reverse flow protect plate. Vaccum efficiency can be improved by operating compressor during evacuation. The bushing pipes for R12 refrigerant shall be melted when they are used for R134a refrigerant causes of leak.
		Vacuum degree	Torr	Below 0.5 (ref)		
		Vacuum	EA	High and low Pressure sides are evacuated at the same time for models above 200ℓ		
		Vacuum piping	EA	Use R134a exclusive manifold.	To protect mixing of mineral and ester oils.	
		Pipe coupler	EA	Use R134a cxclusive.	To protect R12 Refrigerant mixing.	
		Outlet (Socket) Plug		R134a exclusive. R134a exclusive		
5	Refrigerant weighing.	EA	Use R134a exclusively. Weighing allowance:±5g Note:Winter:-5g Summer:+5g	Do not mix with R12 refrigerant.	- Do not weigh the refrigerant at too hot or too cold an area. (25°C[77°F] is adequate.) - Use copper charging canister Socket: 2SV Plug: 2PV R134a Note : Do not burn O-ring (rubber) during welding.	
6	Drier replacement.		-Use R134a exclusively for R134a refrigerator -Replace drier whenever repairing refrigerator cycle piping.	To remove the moisture from pipe.		
7	Leak check.		-Do not use soapy water for check. It may be sucked into the pipe.	Detect refrigerant leak area.	-Check oil leak at refrigerant leak area. Use electronic leak detector if oil leak is not found. -The electronic leak detector is very sensitive to halogen gas in the air. It also can detect R141b in urethane. Please practice therefore many times before use.	

TROUBLE DIAGNOSIS

3-2. Summary Of Heavy Repair

Process	Contents	Tools
		
	- Cut charging pipe ends and discharge refrigerant from drier and compressor.	Filter, side cutters
	- Use R134a oil and refrigerant for compressor and drier - Confirm N ₂ sealing and packing conditions before use. Use good one for welding and assembly. - Weld under nitrogen gas atmosphere. (N ₂ gas pressure: 1.42-2.85 psi). - Repair in a clean and dry place.	Pipe Cutter, Gas welder, N ₂ gas
	- Evacuate for more than forty minutes after connecting manifold gauge hose and vacuum pump to high (drier) and low (compressor refrigerant discharging parts) pressure sides. - Evacuation Speed: 113 liters/minute.	Vacuum pump R134a exclusively, Manifold gauge.
	- Weigh and control the allowance of R134a charging canister in a vacuum conditions to be ± 0.176 oz with electronic scales and charge through compressor inlet (Charge while compressor operates). - Weld carefully after pinching off the inlet pipe.	R134a exclusive charging canister (mass cylinder), refrigerant R134a manifold gauge, electronic scales, pinch-off plier, gas welding machine
	- Check leak at weld joints. <input type="checkbox"/> Minute leak : Use electronic leak detector <input type="checkbox"/> Big leak : Check visually. Note: Do not use soapy water for check. - Check cooling capacity ① Check radiator manually to see if warm. ② Check hot line pipe manually to see if warm. ③ Check frost formation on the whole surface of the evaporator. NOTE: Some tools should be reserved for use with R134a exclusively. Tools and gauges used with R134a should be kept clean and stored separately from other tools to avoid cross- contamination by other refrigerants and lubricants.	Electronic Leak Detector, Driver (Ruler).
	- Remove flux from the silver weld joints with soft brush or wet rag. Flux may be the cause of corrosion and leaks. - Clean R134a exclusive tools and store them in a clean tool box or in their place.	Copper brush, Rag, Tool box
	- Installation should be conducted in accordance with the standard installation procedure. Leave space of more than 5 cm (2 inches) from the wall for compressor compartment cooling fan mounted model.	

TROUBLE DIAGNOSIS

3-3. Precautions During Heavy Repair

Items	Precautions
1. Use of tools.	1) Use special parts and tools for R134a.
2. Recovery of refrigerant.	<p>1) Continue to recover the refrigerant for more than 5 minutes after turning the refrigerator off.</p> <p>2) Install a piercing type valve on the high pressure line (drier side). Then use the appropriate recovery equipment to recover the refrigerant from the system. When the refrigerant has been recovered, install a piercing type valve on the low pressure side. IT IS IMPORTANT TO OPEN THE SYSTEM IN THIS ORDER TO KEEP THE OIL FROM BEING FORCED OUT.</p> <p>The use of piercing type valves will allow future servicing and eliminates the possibility of a defective pinch off.</p> <div data-bbox="602 736 1265 1023" data-label="Diagram"> <p>The diagram illustrates a refrigeration cycle. On the left is the Compressor, with a circled '2' next to its low-pressure port labeled 'Low pressure side'. The refrigerant flows clockwise through the Condenser, then through a vertical Hot Line, then through a Drier. A circled '1' is placed next to the high-pressure side of the drier, with an arrow pointing to a small vertical pipe extending upwards, representing a piercing valve. The cycle then passes through the Evaporator and returns to the compressor.</p> </div>
3. Replacement of drier.	1) Be sure to replace drier with R134a only when repairing pipes and injecting refrigerant.
4. Nitrogen blowing welding.	1) Use pressurized nitrogen to prevent oxidation inside the piping. (Nitrogen pressure : 1.42 - 2.85 psi)
5. Others.	<p>1) Only nitrogen or R134a should be used when cleaning the inside of piping of the sealed system.</p> <p>2) Check leakage with an electronic leakage tester.</p> <p>3) Be sure to use a pipe cutter when cutting pipes.</p> <p>4) Be careful not the water let intrude into the inside of the cycle.</p>

TROUBLE DIAGNOSIS

3-4. Practical Work For Heavy Repair

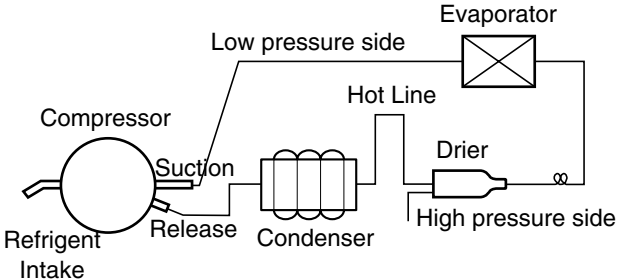
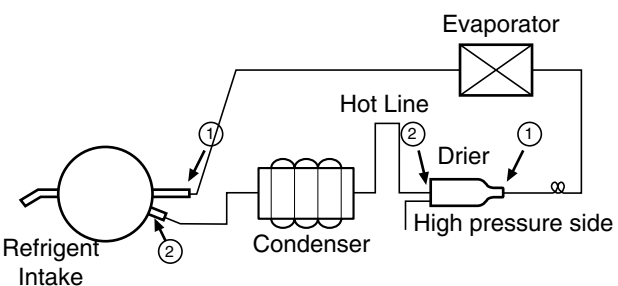
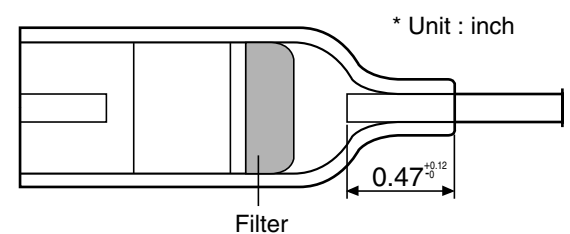
Items	Precautions
<p>1. Removal of residual refrigerant.</p>	<div style="display: flex; justify-content: space-between; align-items: flex-start;"> <div style="text-align: center;">  </div> <div style="width: 25%;"> <p>KEY POINT Observe the sequence for removal of refrigerant. (If not, compressor oil may leak.)</p> </div> </div> <p>1) Continue to recover the refrigerant for more than 5 minutes after turning the refrigerator off.</p> <p>2) Install a piercing type valve on the high pressure line (drier side). Then use the appropriate recovery equipment to recover the refrigerant from the system. When the refrigerant has been recovered, install a piercing type valve on the low pressure side. IT IS IMPORTANT TO OPEN THE SYSTEM IN THIS ORDER TO KEEP THE OIL FROM BEING FORCED OUT.</p> <p>The use of piercing type valves will allow future servicing and eliminates the possibility of a defective pinch off.</p>
<p>2. Nitrogen blowing welding.</p>	<div style="display: flex; justify-content: space-between; align-items: flex-start;"> <div style="text-align: center;">  </div> <div style="width: 25%;"> <p>KEY POINT Welding without nitrogen blowing produces oxidized scales inside a pipe, which affect performance and reliability of a product.</p> </div> </div> <p>When replacing a drier: Weld ① and ② parts by blowing nitrogen (1.42-2.85 psi) to high pressure side after assembling a drier.</p> <p>When replacing a compressor: Weld ① and ② parts by blowing nitrogen to the low pressure side.</p> <p>Note) For other parts, nitrogen blowing is not necessary because it does not produce oxidized scales inside pipe because of its short welding time.</p>
<p>3. Replacement of drier.</p>	<div style="display: flex; justify-content: space-between; align-items: flex-start;"> <div style="text-align: center;">  </div> <div style="width: 25%;"> <p>KEY POINT Be sure to check the inserted length of capillary tube when it is inserted. (If inserted too far, the capillary tube will be blocked by the filter.)</p> </div> </div> <p>Inserting a capillary tube Measure distance with a ruler and put a mark(0.47^{+0.12}/₋₀)on the capillary tube. Insert tube to the mark and weld it</p>

TROUBLE DIAGNOSIS

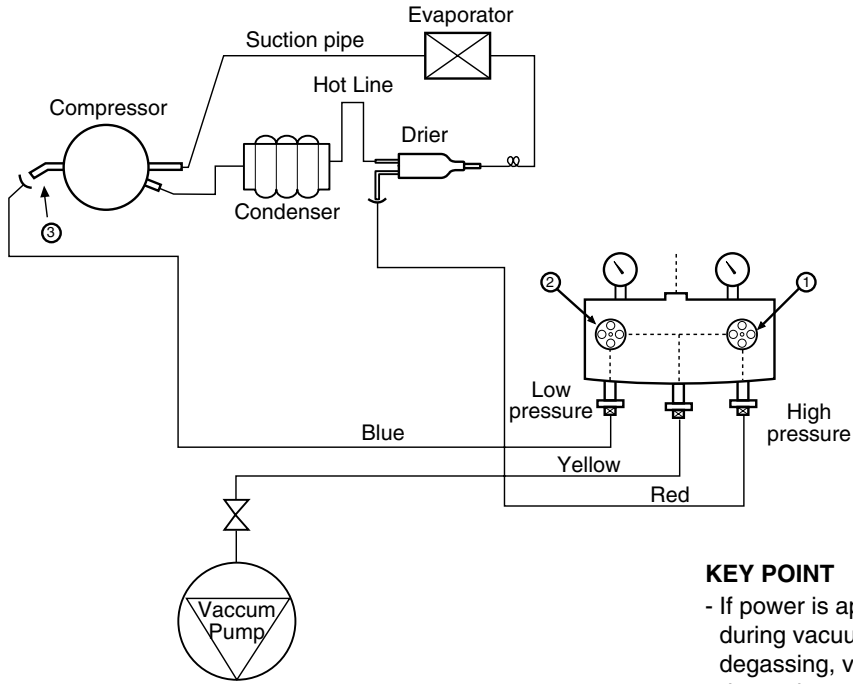
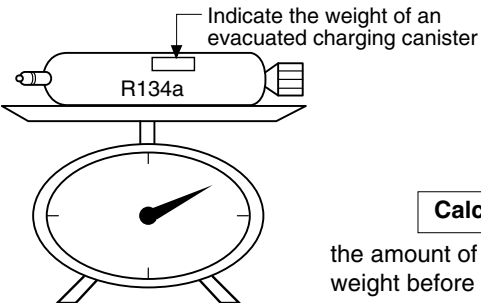
Items	Precautions
<p>4. Vacuum degassing.</p>	<div style="text-align: center;">  </div> <p>Pipe Connection Connect the red hose to the high pressure side and the blue hose to the low pressure side.</p> <p>Vacuum Sequence Open valves ① and ② and evacuate for 40 minutes. Close valve ①.</p> <p>KEY POINT</p> <ul style="list-style-type: none"> - If power is applied during vacuum degassing, vacuum degassing will be more effective. - Run the compressor while charging the system. It is easier and works better.
<p>5. Refrigerant charging.</p>	<p>Charging sequence</p> <ol style="list-style-type: none"> 1) Check the amount of refrigerant supplied to each model after completing vacuum degassing. 2) Evacuate charging canister with a vacuum pump. 3) Measure the amount of refrigerant charged. <ul style="list-style-type: none"> - Measure the weight of an evacuated charging canister with an electronic scale. - Charge refrigerant into a charging canister and measure the weight. Calculate the weight of refrigerant charged into the charging canister by subtracting the weight of an evacuated charging canister. <div style="text-align: center;">  </div> <p>KEY POINT</p> <ul style="list-style-type: none"> - Be sure to charge the refrigerant at around 25°C [77°F]. - Be sure to keep -5g in the winter and +5g in summer. <div style="border: 1px solid black; padding: 5px; text-align: center; margin: 10px auto; width: fit-content;"> Calculation of amount of refrigerant charged </div> <p>the amount of refrigerant charged = weight after charging - weight before charging (weight of an evacuated cylinder)</p>

TROUBLE DIAGNOSIS

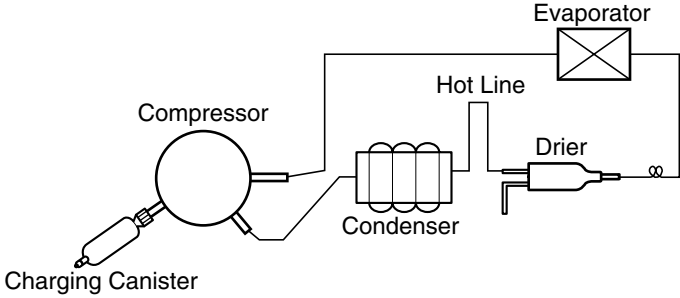
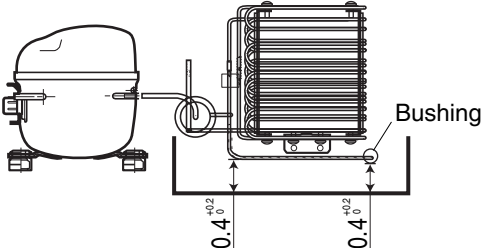
Items	Precautions
	 <p>4) Refrigerant Charging Charge refrigerant while operating a compressor as shown above.</p> <p>5) Pinch the charging pipe with a pinch-off plier after completion of charging.</p> <p>6) Braze the end of a pinched charging pipe with copper brazer and make a gas leakage test on the welded parts.</p>
6. Gas-leakage test	* Test for leaks on the welded or suspicious area with an electronic leakage tester.
7. Pipe arrangement in each cycle	<p>When replacing components, be sure each pipe is replaced in its original position before closing the cover of the mechanical area.</p> 

3-5. Standard Regulations For Heavy Repair

- 1) Observe the safety precautions for gas handling.
- 2) Use JIG (or a wet towel) in order to prevent electric wires from burning during welding. (In order to prevent insulation break and accident.)
- 3) The inner case will melt and the insulation will burn.
- 4) The copper piping will oxidize.
- 5) Do not allow aluminum and copper pipes to touch. (In order to prevent corrosion.)
- 6) Observe that the inserted length of a capillary tube into a drier should be $0.47^{+0.12}_{-0}$ mm.

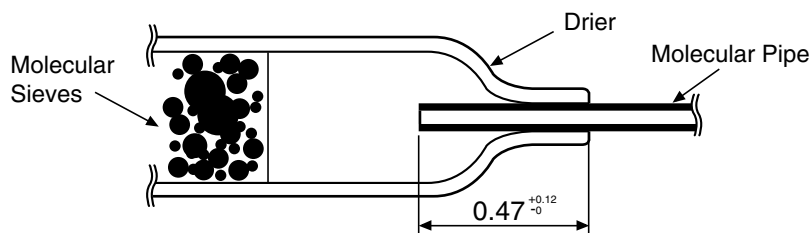

- 7) Make sure that the inner diameter is not distorted while cutting a capillary tube.
- 8) Be sure that the suction pipe and the filling tube should not be substituted each other during welding. (High efficiency pump.)

TROUBLE DIAGNOSIS

3-6. Brazing Reference Drawings

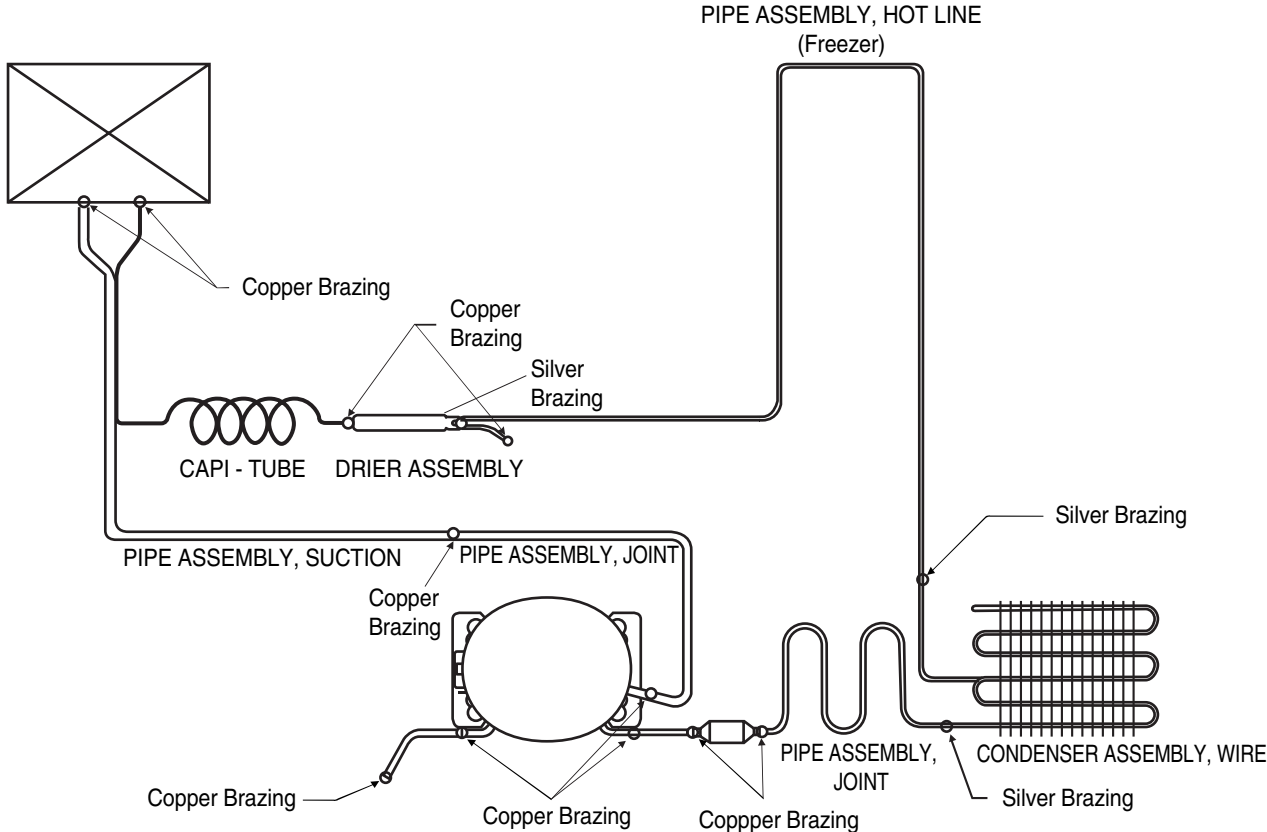

TROUBLE DIAGNOSIS

4. HOW TO DEAL WITH CLAIMS

4-1. Sound

Problems	Checks and Measures
Hiss	<ul style="list-style-type: none"> ■ Explain general principles of sounds. <ul style="list-style-type: none"> • All refrigerators make noises when they run. The compressor and fan produce sounds. There is a fan in the freezer compartment which blows cool air to freezer and refrigerator compartments. Hissing is sounds are heard when the air passes through the narrow holes into the freezer and refrigerator compartments. ■ Cooling Fan sound in the compressor compartment. <ul style="list-style-type: none"> • There is a fan on the back of the refrigerator which cools the compressor compartment. If there is a small space between the refrigerator and the wall, the air circulation sounds may be noticeable. ■ Noise of Compressor. <ul style="list-style-type: none"> • This operating sound happens when the compressor compresses the refrigerant. The compressor rotates at 3600 RPM. The sound of compressor Bigger refrigerators make more noise than small ones
Click	<ul style="list-style-type: none"> ■ Explain the principles of temperature change. <ul style="list-style-type: none"> • The sounds happens when pipes and internal evaporator in the refrigerator compartment expand and contract as the temperature changes during the refrigerator operation. This sound also happens during defrosting, twice a day, when the ice on the evaporator melts.
Clunk	<ul style="list-style-type: none"> ■ Explain that it comes from the compressor when the refrigerator starts. <ul style="list-style-type: none"> • When the refrigerator operates, the piston and motor in the compressor rotate at 3600 RPM. This sound is caused by the vibration of motor and piston when they start and finish their operation. This phenomenon can be compared with that of cars. When an automobile engine starts, it is loud at first but quiets down quickly. When the engine stops, so does the vibration.
Vibration	<ul style="list-style-type: none"> ■ Check the sound whether it comes from the pipes vibration and friction. <ul style="list-style-type: none"> • Insert bushing or leave a space between pipes to avoid the noise. • Fix the fan blade if it is hitting on the shroud • Fix the drip tray if it is loosened. ■ Sound depends on the installation location. <ul style="list-style-type: none"> • Sound becomes louder if the refrigerator is installed on a wooden floor or near a wooden wall. Move it to the another location. • If the refrigerator is not leveled properly, a small vibration can make a loud sound. Please adjust the level of the refrigerator.

TROUBLE DIAGNOSIS

Problems	Checks and Measures
<p>Sounds of water flowing</p>	<p>■ Explain the flow of refrigerant.</p> <ul style="list-style-type: none"> • When the refrigerator stops, the water flowing sound happens. This sound happens when the liquid or vapor refrigerant flows from the evaporator to compressor.
<p>Click</p>	<p>■ Explain the characteristics of moving parts.</p> <ul style="list-style-type: none"> • This noise comes from the MICOM controller's switch on the top of the refrigerator when it is turned on and off.
<p>Noise of Icemaker operation (applicable to model with Icemaker).</p> <ul style="list-style-type: none"> - Noise produced by ice dropping and hitting ice bin. - Noise from motor sounds Hiss. 	<p>■ Explain the procedure and principles of Icemaker operation.</p> <ul style="list-style-type: none"> • The automatic icemaker continuously cycles through water supply → icemaking → ice ejection → repeat. When water is dispensed, the water supply valve in the mechanical area makes hissing sounds and you can hear the water flow. When water freezes, you can hear clicking. When ice is ejected, you can hear the motor run, the tray twist, and ice breaking and falling into the bin.
<p>Noise when dispensing water.</p>	<p>■ Explain the principles of water supplied to dispenser.</p> <ul style="list-style-type: none"> • When the water supply button in the dispenser is pressed, the water supply valve in the compressor compartment opens and let the water flow to the water tank in the lower part of the refrigerator compartment. The water is dispensed by this pressure. When this happens, motor sound and water flowing sound are heard.
<p>Noise when dispensing ice.</p>	<p>■ Explain the principles of ice supply and procedure of crushed icemaking in a dispenser.</p> <ul style="list-style-type: none"> • When ice cube button is pressed, ice stored in the ice bin is moved by an auger and dispensed. If crushed ice button is pressed, the ice cube is crushed. When this happens, ice crushing and hitting ice bin sounds are heard.

TROUBLE DIAGNOSIS

4-2. Measures for Symptoms on Temperature

Problems	Checks and Measures
Refrigeration is weak.	<p>■ Check temperature set in the temperature control knob.</p> <ul style="list-style-type: none"> • Refrigerator is generally delivered with the button set at normal use (MID). But customer can adjust the temperature set depending on their habit and taste. If you feel the refrigeration is weak, then set the temperature control button at strong position. If you adjust the button in the freezer compartment as well, the refrigeration is stronger than adjusting refrigerator only.
The food in the chilled drawer is not frozen but defrosted	<p>■ The chilled drawer does not freeze food.</p> <ul style="list-style-type: none"> • Use chilled drawer for storing fresh meat or fish for short periods. For storing for a long periods or freezing food, use a freezer compartment. It is normal that frozen foods thaw above the freezing temperature (in the chilled drawer).
Refrigerator water is not cool.	<p>■ Check the water storage location.</p> <ul style="list-style-type: none"> • If water is kept in the door rack, move it to a refrigerator shelf. It will then become cooler.
Ice cream softens.	<p>■ Explain the characteristics of ice cream.</p> <ul style="list-style-type: none"> • Because of its ingredients, ice cream melts beginning at 18°F (-8°C). Ice cream will still be soft when ice is still frozen solid. Consequently it should be stored on a lower shelf in the freezer and not in the door. • Store ice cream in a cold place or set the temperature control button of a freezer at strong position.
Refrigeration is too strong.	<p>■ Check the position of temperature control button.</p> <ul style="list-style-type: none"> • Check if refrigeration is strong in whole area of the refrigerator or partly near the outlet of the cooling air. If it is strong in whole area, set the control button at weak. If it is strong only near the outlet of cool air, keep food (especially damp foods and easily frozen foods) away from the outlet.
Vegetables are frozen.	<p>■ Check the vegetables storage.</p> <ul style="list-style-type: none"> • If vegetables are stored in the refrigerator shelf or chilled drawer instead of vegetable drawer, they will be frozen. Set the control button at weak if they are also frozen in the vegetable drawer.
The food stored at inside of the shelf freezes even the control button is set at MID .	<p>■ Check if food is stored near the outlet of the cooling air.</p> <ul style="list-style-type: none"> • The temperature at cooling air outlet is always below the freezing point. Do not store food near the outlet of the cooling air as it block the air circulation. Do not block the outlet. If the outlet of the cooling air is blocked, the refrigerator compartment will not be cooled.

TROUBLE DIAGNOSIS

4-3. Odor and Frost

Problems	Checks and Measures
Odor in the refrigerator compartment.	<ul style="list-style-type: none"> ■ Explain the basic principles of food odor. <ul style="list-style-type: none"> • Each food has its own particular odor. Therefore it is impossible to prevent or avoid food odor completely when food is stored in the completely sealed refrigerator compartment. The deodorizer can absorb some portions of the odor but not all. The intensity of odor depends on refrigerator conditions and environments. ■ Check the temperature control button and set at STRONG. <ul style="list-style-type: none"> • Clean inside of the refrigerator with detergent and remove moisture. Dry inside the refrigerator by opening the door for about 3 or 4 hours and then set the temperature control button at STRONG.
Frost in the freezer compartment	<ul style="list-style-type: none"> ■ Explain the basic principles of frost formation. <ul style="list-style-type: none"> • The main causes for frosting: <ul style="list-style-type: none"> - Door was left open. - Air penetration through the gasket - Too frequent door opening. (parties. etc.) - Hot foods are stored before they are cooled down. The temperature of freezer is -19°C [-2.2°F]. if temperature is set at MID. If hot air comes into the refrigerator, fine frost forms as cold air mixes with hot air. If this happens quite often, much frost forms inside of the refrigerator. If the door is left open in Summer, ice may form inside of the refrigerator.
Frost in ice tray.	<ul style="list-style-type: none"> ■ Explain basic principles of frost formation. <ul style="list-style-type: none"> • When ice tray with full of water is put into a freezer compartment, the water evaporates. If cool air fan operates, the moisture attached to the jaw (protruded part) of ice mold will freeze and form frost. If warm water was put into the ice mold, the situation will become worse.

TROUBLE DIAGNOSIS

4-5. Others

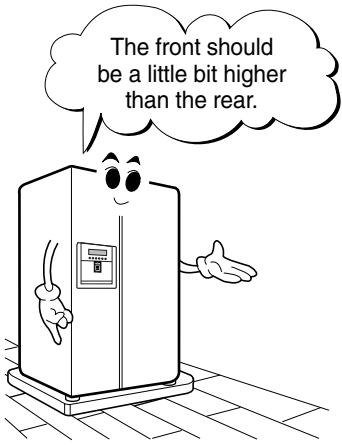
Problems	Checks and Measures
The refrigerator case is hot.	<ul style="list-style-type: none"> ■ Explain the principles of radiator. <ul style="list-style-type: none"> • The radiator pipes are installed in the refrigerator case and partition plate between the refrigerator and the freezer compartment in order to prevent condensation formation. Particularly in summer or after installation of refrigerator, it may feel hot but it is normal. If there is not enough space to dissipate heat, it can be hotter due to lack of heat radiation. Please install a refrigerator in a well-ventilated place and leave the clearance between refrigerator and wall:
Small holes in door liner	<ul style="list-style-type: none"> ■ Explain that the small holes are to release pressure during the manufacturing process. <ul style="list-style-type: none"> • It helps to make a better fit when plastic is vacuum molded and formed and when foam insulation is blown in under pressure.
Electric bills are too much.	<ul style="list-style-type: none"> ■ Explain that the hole is to allow the air to escape when vacuum forming plastic parts and pumping foam insulation into cavities. There are small holes in the plastic liner of some parts of the refrigerator. These holes allow plastic parts to be injection molded and vacuum formed by allowing air bubbles to be expelled. They also allow foam insulation to be pumped into cavities where air bubbles may build up.
Condensation on the inside wall of the refrigerator compartment and the cover of properly vegetable drawer.	<ul style="list-style-type: none"> ■ Explain how to store foods <ul style="list-style-type: none"> • Condensation forms when refrigerator is installed at damp area, door is frequently opened, and wet foods are not stored in the air tight container or wrapped. Be sure to store wet foods in airtight containers or securely covered in plastic wrap.
When is the power connected?	<ul style="list-style-type: none"> ■ When should the power be connected ? <ul style="list-style-type: none"> • You can connect the power immediately after installation. However, if the refrigerator was laid flat before or during installation, you must stand it upright for 6 hours before plugging it in. This allows the refrigerant oils to return to the sump in the compressor. If you operate the refrigerator before the oil has had a chance to settle, you could damage the compressor.
Door does not open properly. <div style="text-align: center; margin-top: 20px;">  </div>	<ul style="list-style-type: none"> ■ Refrigerator compartment door does not open properly. <ul style="list-style-type: none"> • When the door is opened, warm air gets into the refrigerator. As it cools, it sometimes forms a slight vacuum. Pull the door gently to open it. This is normal and causes no harm. ■ When the refrigerator compartment door is opened and closed, the freezer compartment door moves up and down. <ul style="list-style-type: none"> • When one of the doors is closed too forcefully, it can create a slight compression and cause the other door to open slightly. This is normal. Close the door lightly to eliminate this problem. If the doors are adjusted properly (the refrigerator is leveled properly,) the doors will fall closed by themselves. ■ Door opens too easily. <ul style="list-style-type: none"> • There is a magnet in the gasket so it closes securely without a gap. It can be held open easily if something is in the way and obstructs the door's closing. ■ A door does not close properly. <ul style="list-style-type: none"> • If the refrigerator is not properly leveled, the doors will not close easily. Adjust the level using the leveling screws under the front of the refrigerator.

HOW TO DISASSEMBLE AND ASSEMBLE

1. DOOR

1) Remove lower cover and then disconnect water supply tube in the lower part of freezer door.

- Pull the water supply tube ② forward while pressing on the coupling ① as shown in the drawing.

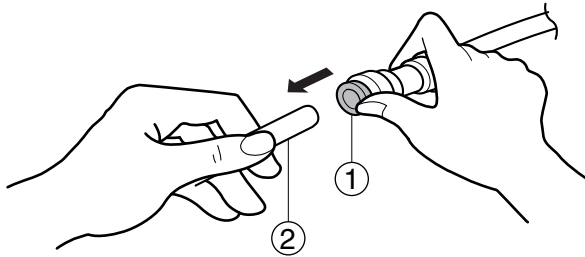

- ⚠ Disconnecting the tube under the door causes about 1.5 liters water to flow out. Please put up a big container to prevent it.

2) Remove the freezer door.

- (1) Loosen hinge cover screw of freezer door and remove cover. Disconnect all connecting lines except grounding cord.

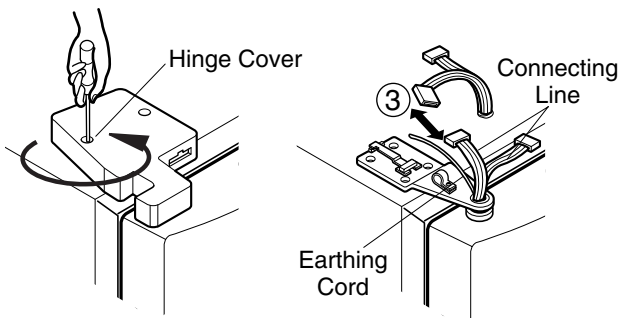

- (2) Turn hinge lever in arrow (A) direction until it is loosened and take it out in arrow (B) direction.

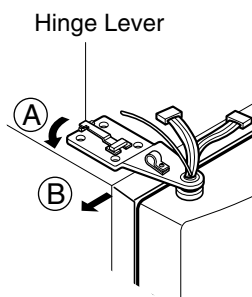

- Note :** • When disconnecting refrigerator door, turn hinge lever counterclockwise.

- If the hinge or bracket are bent during assembly, use two extra screws (Tap Tite M6, Left Hinge attaching screw) in the holes of the upper hinge.

- (3) Disconnect upper hinge ④ from the hinge supporter ⑤ by grasping the front part of upper hinge and lifting up the Upper Hinge Assembly in the direction of the arrow (C) and pull forward in arrow (D) direction. Be careful because the door may fall, damaging the door, the floor, or injuring you.

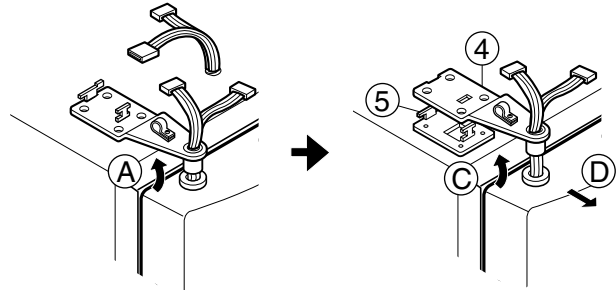

- (4) Lift up the freezer door ⑥ in arrow direction and disconnect the door from the lower hinge ⑦. Don't pull the door forward.

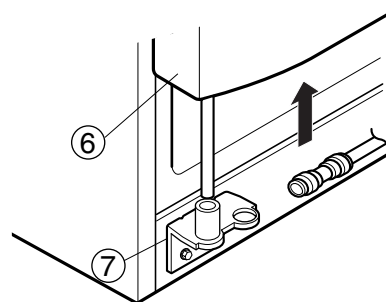

- Note :** • Lift up the freezer door until the water supply tube is fully removed.

- (5) Assembly is the reverse order of disassembly

HOW TO DISASSEMBLE AND ASSEMBLE

2. HANDLE

1. Aluminum Handle Model

- 1) Use a small screwdriver blade in the groove at the side of the Deco Handle to lift and separate the cover. Twist down in the direction of arrow ① and lift the cover in the direction of arrow ②.

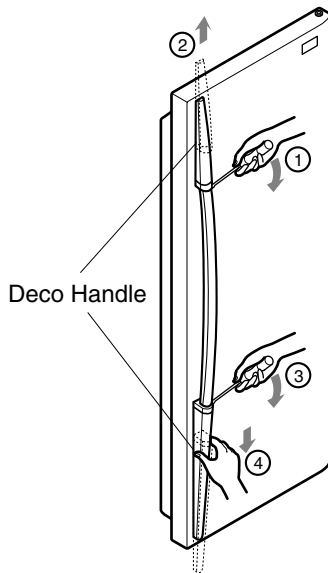

- 2) Use a small screwdriver blade in the groove at the side of the Deco Handle to lift and separate the cover. Twist down in the direction of arrow ③ and lift the cover in the direction of arrow ④.
- 3) Push the handle piece ③ in the direction of the arrow and disconnect it.
- 4) Turn screw in arrow direction with a philips driver and disconnect.

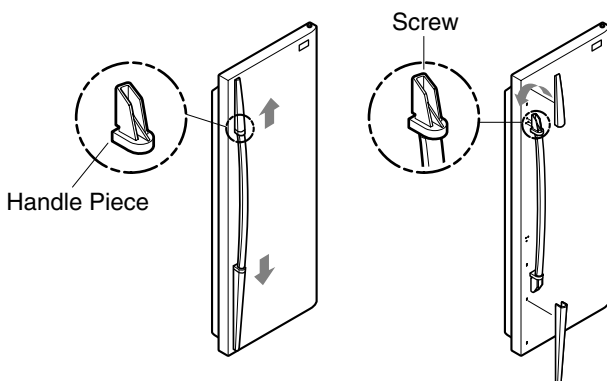

2. Aluminum short handle Model

- 1) Grasp the handle by both hands and push it upward.

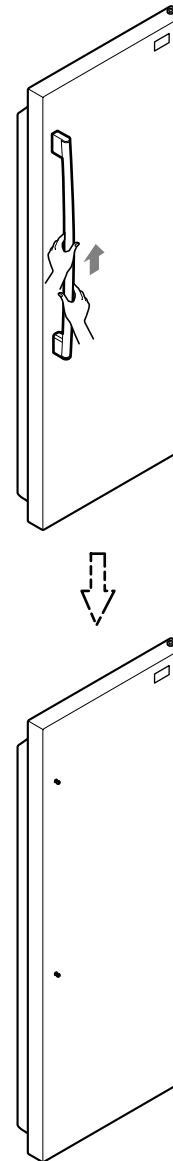

HOW TO DISASSEMBLE AND ASSEMBLE

3. FAN SHROUD GRILLE

- 1) Loosen one screw with a screwdriver blade.
- 2) Disassembly of an upper grille fan : Hold upper part of an upper grille fan and pull forward carefully.
- 3) Disconnect housing A of an upper grille fan from the main body.
- 4) Disassembly of a lower grille fan : Hold upper part of a lower grille fan and pull forward carefully.
- 5) Disassembly of an upper freezer shroud : Hold lower part and pull forward
- 6) Disassembly of an upper freezer shroud : Disconnect housing B
- 7) Check foam sticking conditions around a shroud, upper freezer and low freezer during assembling. if damaged, torn, or badly stuck, assemble with a new one after sealing well.

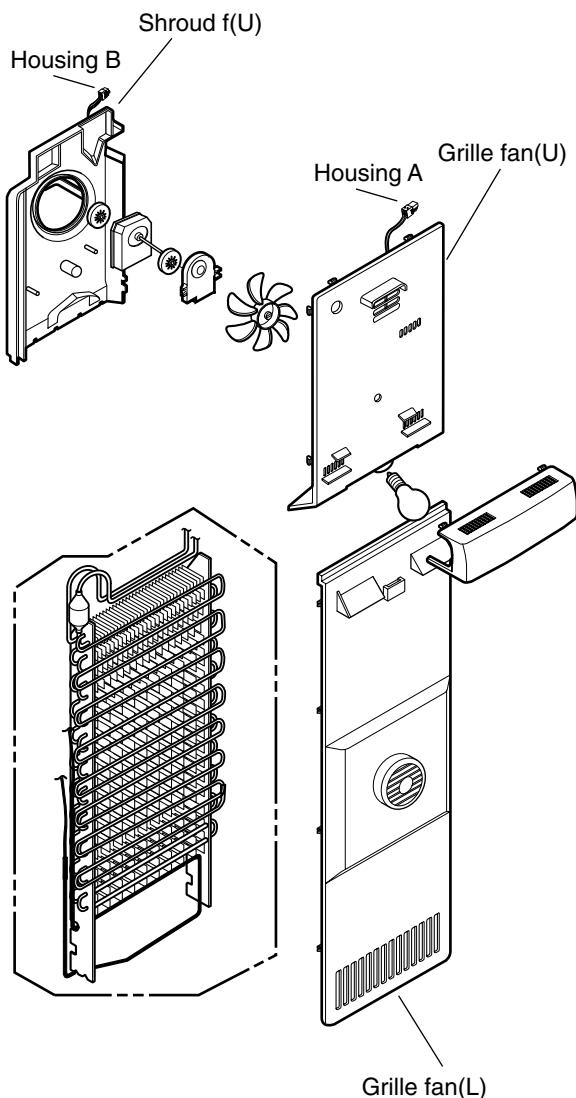

4. ICEMAKER ASSEMBLY

1. Dispenser Model

- 1) How to disassemble:
 - (1) Remove ice bin from the freezer compartment.
 - (2) Loosen two screws on the upper part of icemaker bracket.
 - (3) Disconnect icemaker bracket so that it can slide forward.
 - (4) Disconnect icemaker housing and sensor housing.
 - (5) Disconnect icemaker horizontally by pressing bracket hook part. (Don't disassemble further. The set value may be changed.)
- 2) The assembly is the reverse order of the above disassembly.

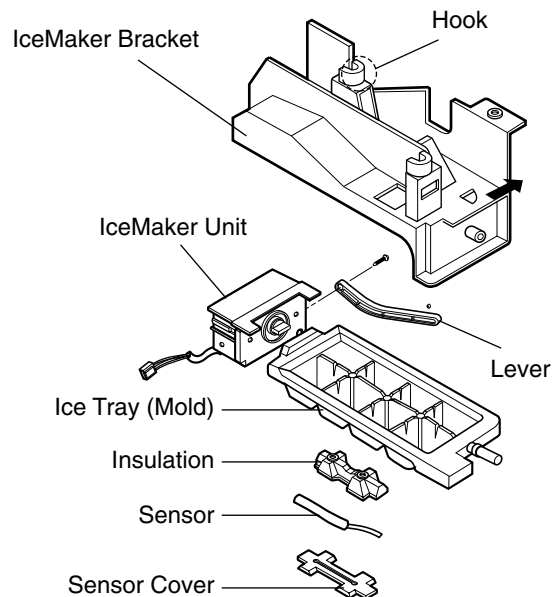

NOTE: If the ice tray (mold) is not horizontal after repair and assembly, something must be wrong. Check it and reassemble if necessary.

HOW TO DISASSEMBLE AND ASSEMBLE

5. WATER-VALVE DISASSEMBLY

METHOD

- 1) Turn off the power of the refrigerator (pull out the plug).
Open the F/R Door and disassemble the Lower Cover.



- 2) Lay a dry towel on the floor and get ready to pour water from the water tank.
Then press the collet to separate the tube from the connector and pour out the water until emptied.
(Refer to the label attached on Front L on how to separate the tube.)

*Disassembly

1. Remove clip. (Retire la abrazadera.)
2. Pull out tube while presiona
(Extraiga el tubo mientras presiona los anillos metalicos y desmontelo.)

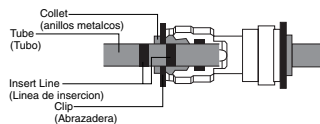

*Assembly

1. Insert tube until you can see only one line.
(Inserte el tubo hasta que solo puesa ver una linea.)
2. After inserting, pull out tube to check if it's properly inserted.
(Tras insertarlo, extraiga el tubo para comprobar si ha sido insertado correctamente.)
3. Assemcie clip. (Monte la abrazadera.)

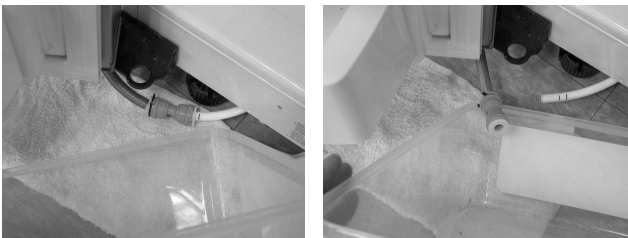

- 3) Lock the water being supplied. Then separate the Water Connection connected to the Water Valve.

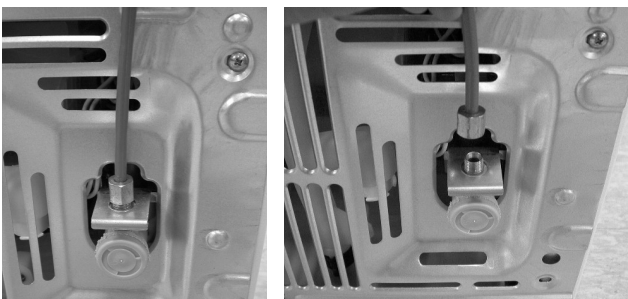

- 4). Separate the Cover Back M/C and Valve Screw.



- 5) Separate the housing and pull out the valve.

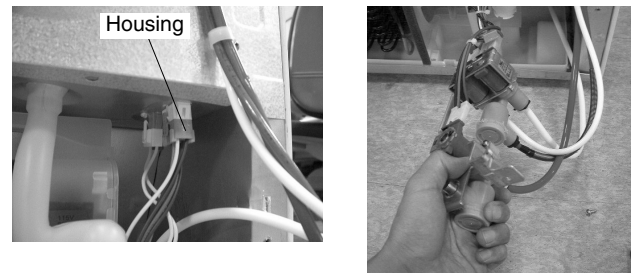

6. FAN AND FAN MOTOR DISASSEMBLY

METHOD

- 1) Using a short screw driver, loosen one SCREW in DRAIN ASSEMBLY, PIPE-Z and one connected to the COVER, MOTOR.

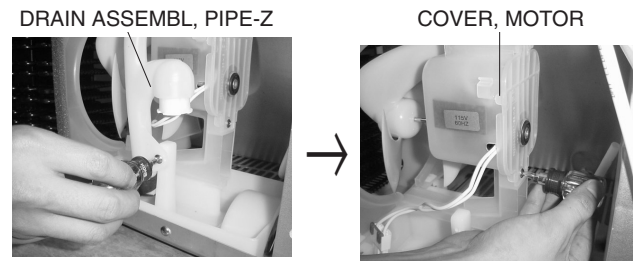

- 2) Pull and separate the FAN ASSEMBLY and MOTOR in counter clockwise based on the MOTOR SHAFT.

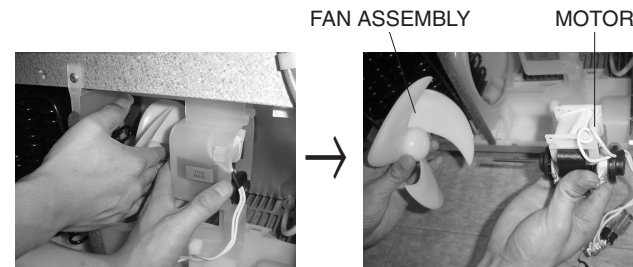

The assembly is in the reverse order of the disassembly and take special care for the following details.

1. Be careful not to bend the tube during assembly.
2. Press the WATER DISPENSER button until water pours out and check for leakage in the CONNECTOR TUBE (It differs by the water pressure but usually takes about 2 minutes until water pours out.)

HOW TO DISASSEMBLE AND ASSEMBLE

7. DISPENSER

- 1) Disconnect funnel and button assembly by pulling down and forward.

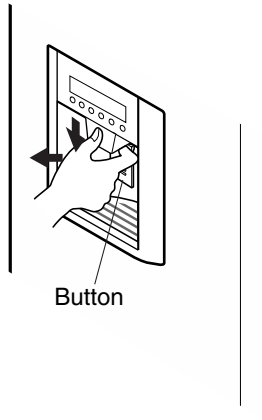

- 4) Loosen four screws with a phillips screwdriver and pull the Funnel Assembly to disconnect.

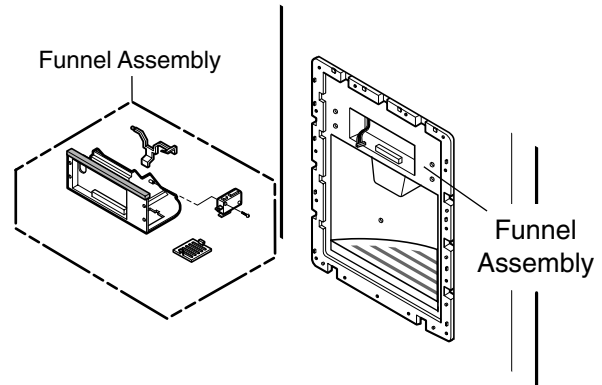

- 2) Remove the Display Frame by pressing a screwdriver between the Frame and the Door and pulling it forward. Insert the screwdriver at the bottom (see drawing, below.) The Frame is attached by hooks at the top. Pull the bottom out and lift the frame up.

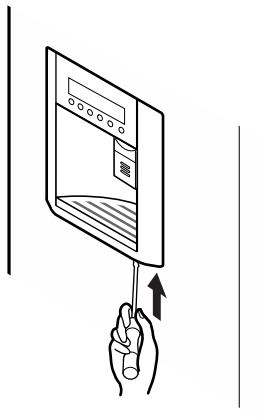

- 5) The Duct Cap Assembly can be disconnected if the hold lever connecting screw is loosened with a phillips driver.

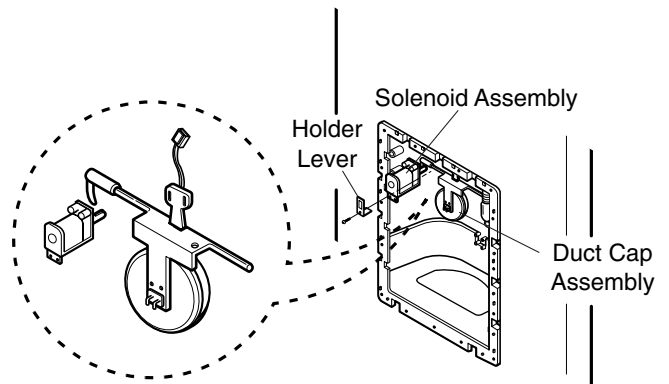

- 3) The Display Assembly can be connected by pressing the top of the Dispenser Cover and pushing it after separating the Display Frame from its housing.

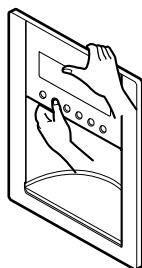

- 6) To install the Duct Cap Assembly, insert one end of the spring into the right hole of the dispenser lever and insert the other end into the right hole in the top part of the dispenser. Then attach the holder at the solenoid switch.

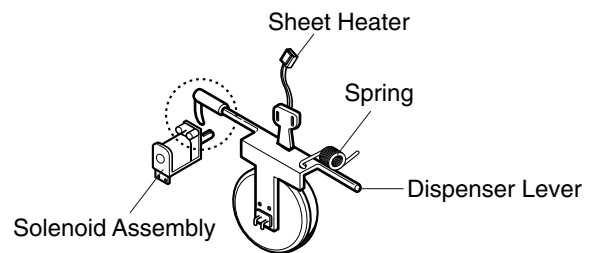

HOW TO DISASSEMBLE AND ASSEMBLE

7) Dispenser Related Parts

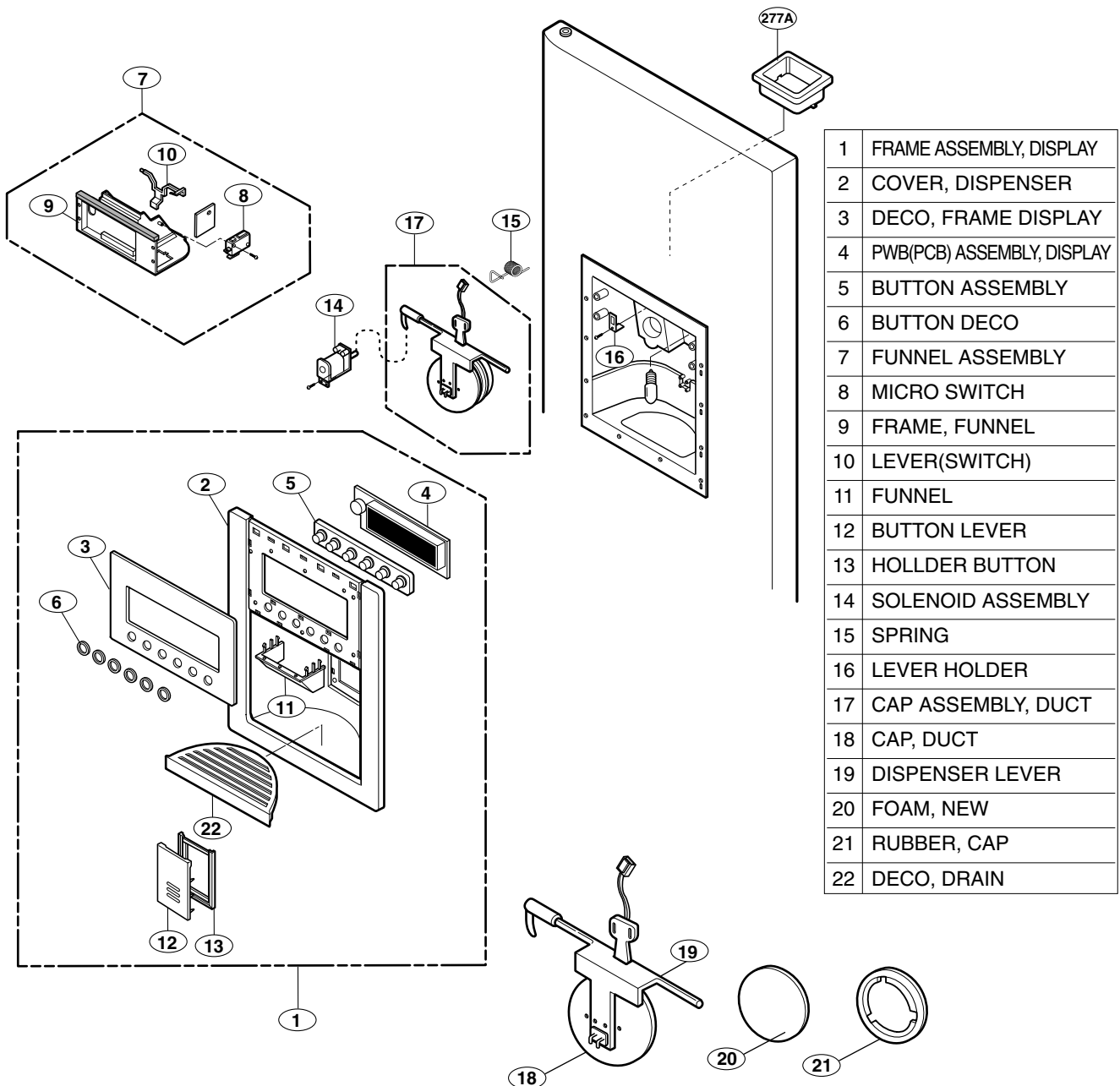

⑰ Cap Assembly, Duct Detailed Drawings

EXPLODED VIEW

FREEZER DOOR PART: LSC26905TT (Refer to appendix)

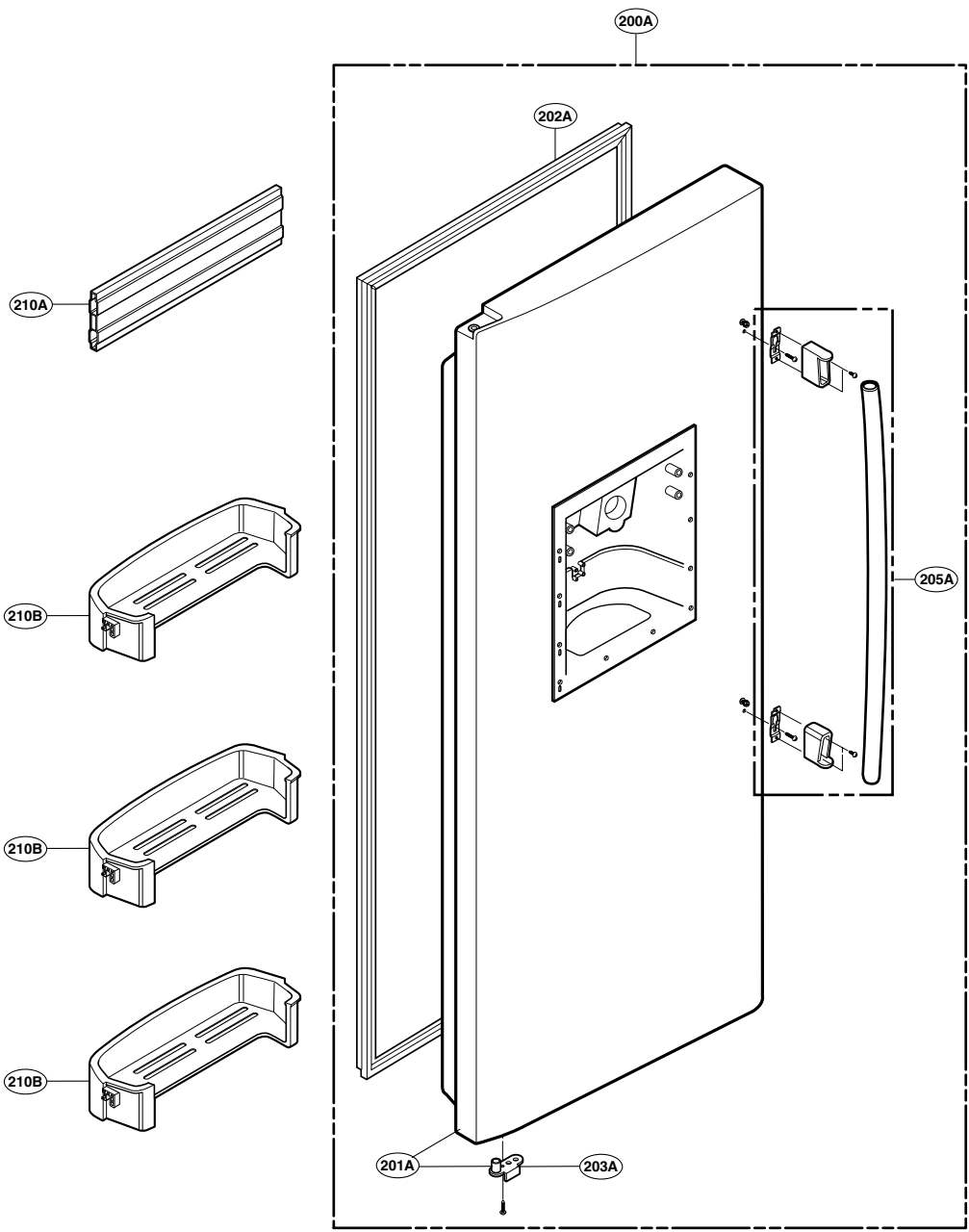

EXPLODED VIEW

REFRIGERATOR DOOR PART: LSC26905TT (Refer to appendix)

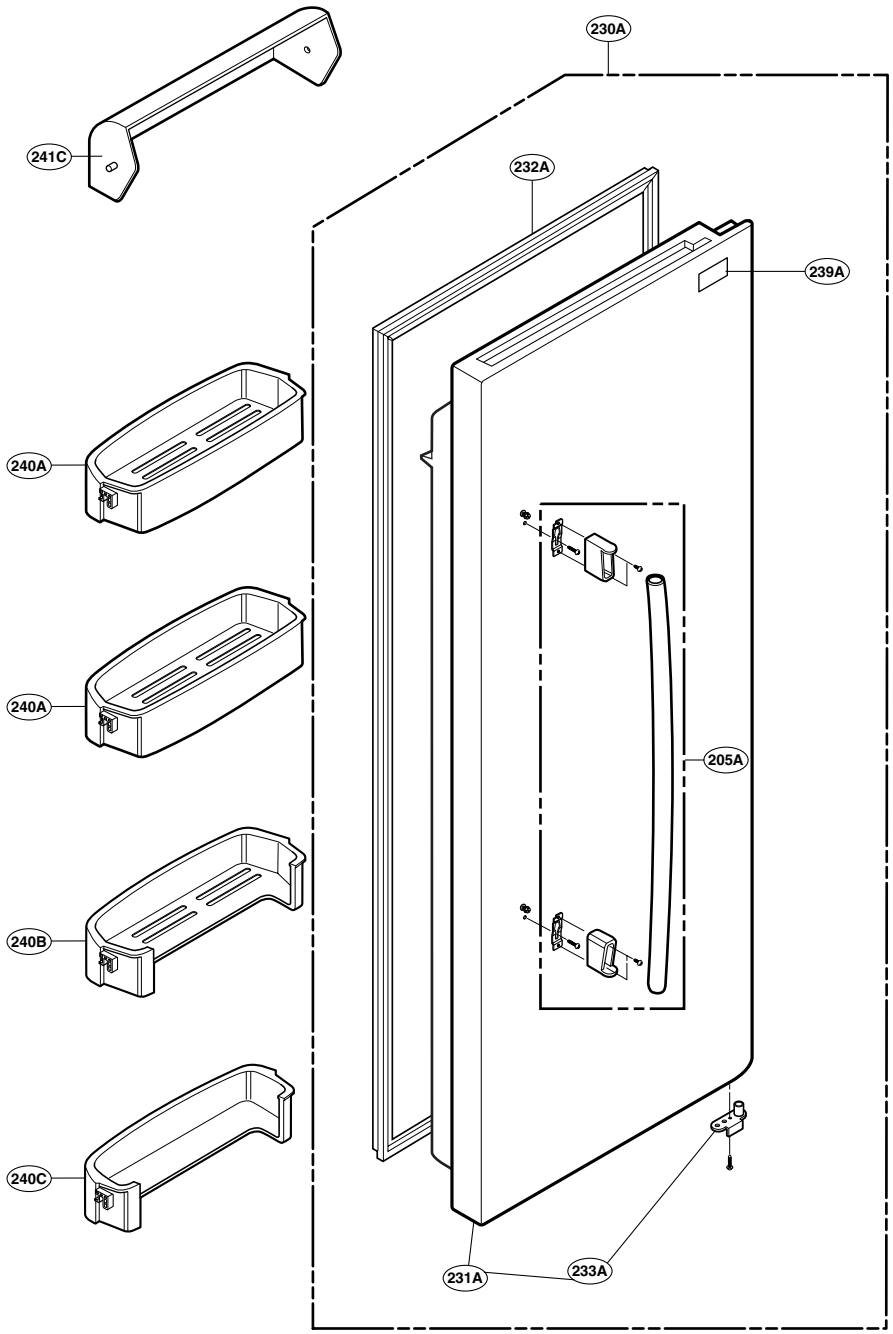

EXPLODED VIEW

FREEZER COMPARTMENT: LSC26905TT (Refer to appendix)

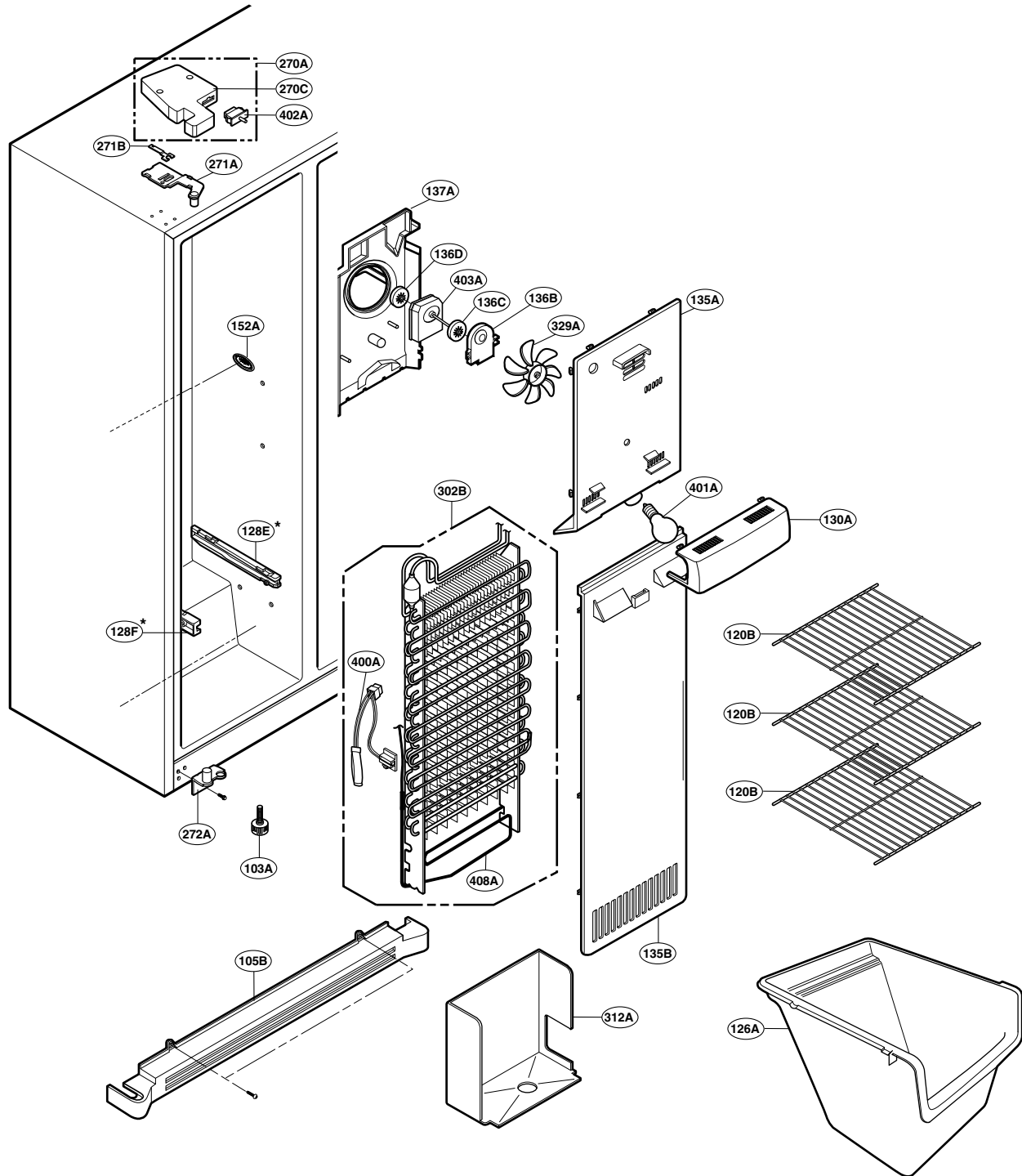

EXPLODED VIEW

REFRIGERATOR COMPARTMENT: LSC26905TT (Refer to appendix)

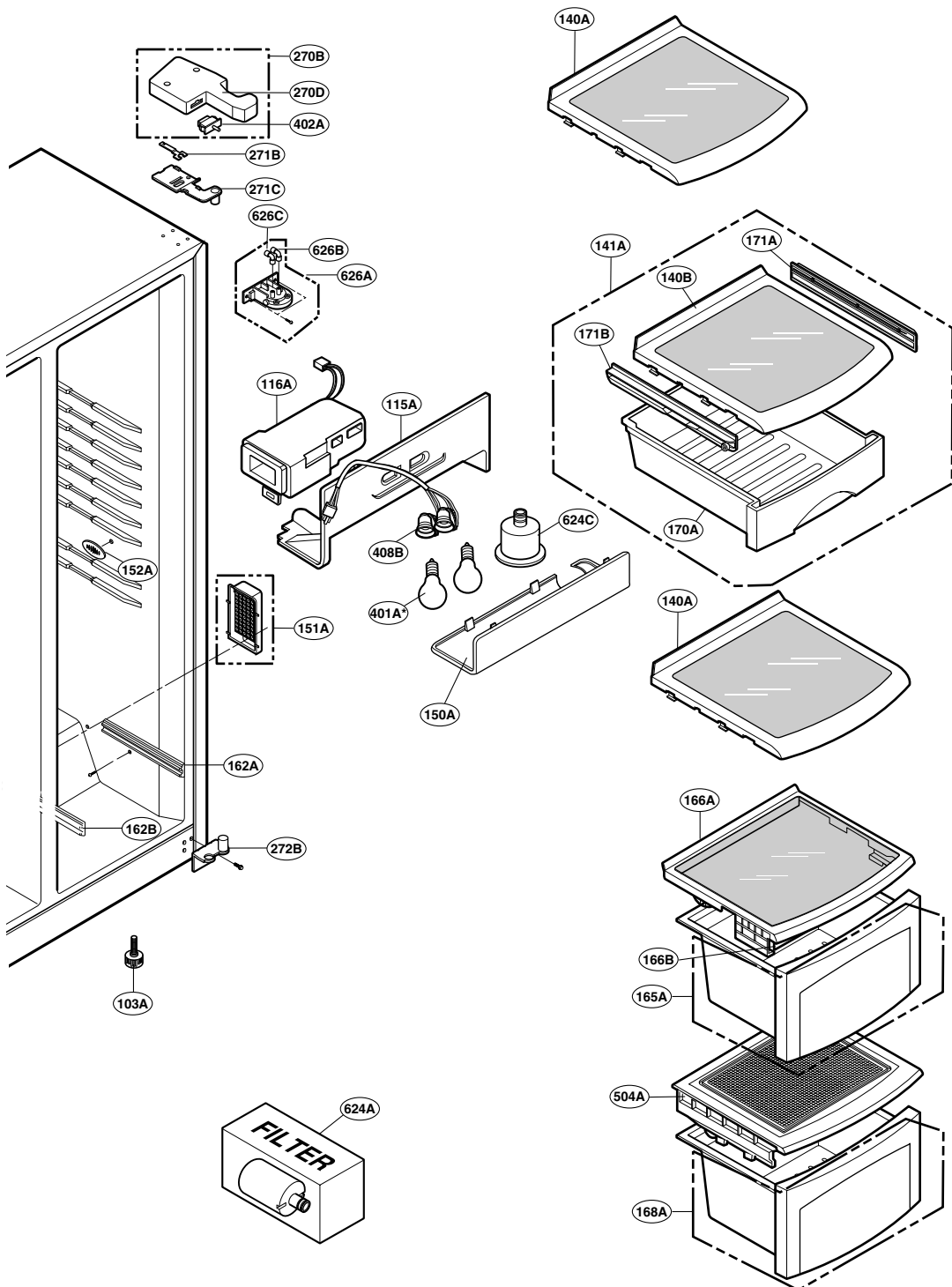

EXPLODED VIEW

ICE & WATER PART: LSC26905TT (Refer to appendix)

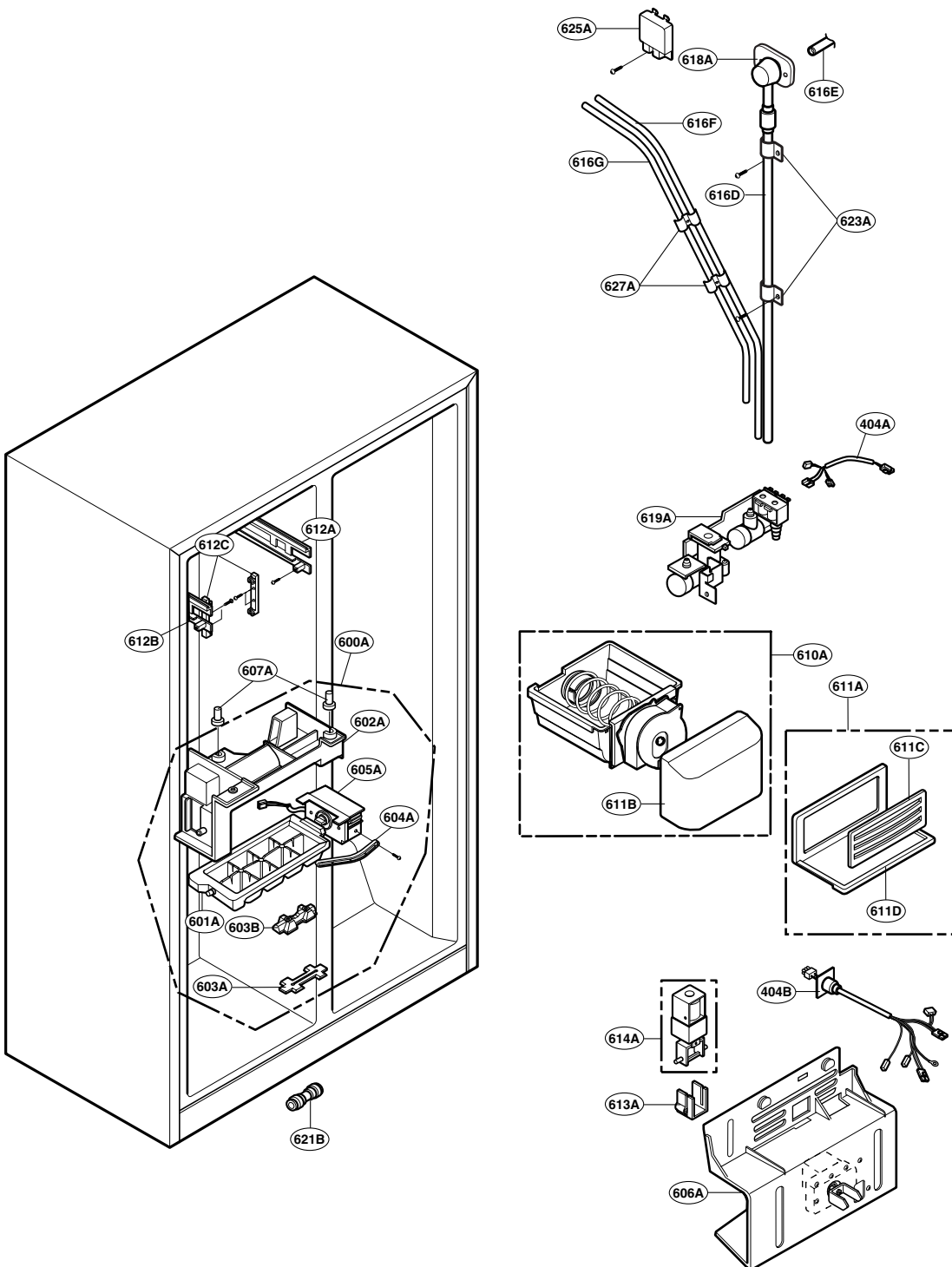

EXPLODED VIEW

MECHANICAL COMPARTMENT: LSC26905TT (Refer to appendix)

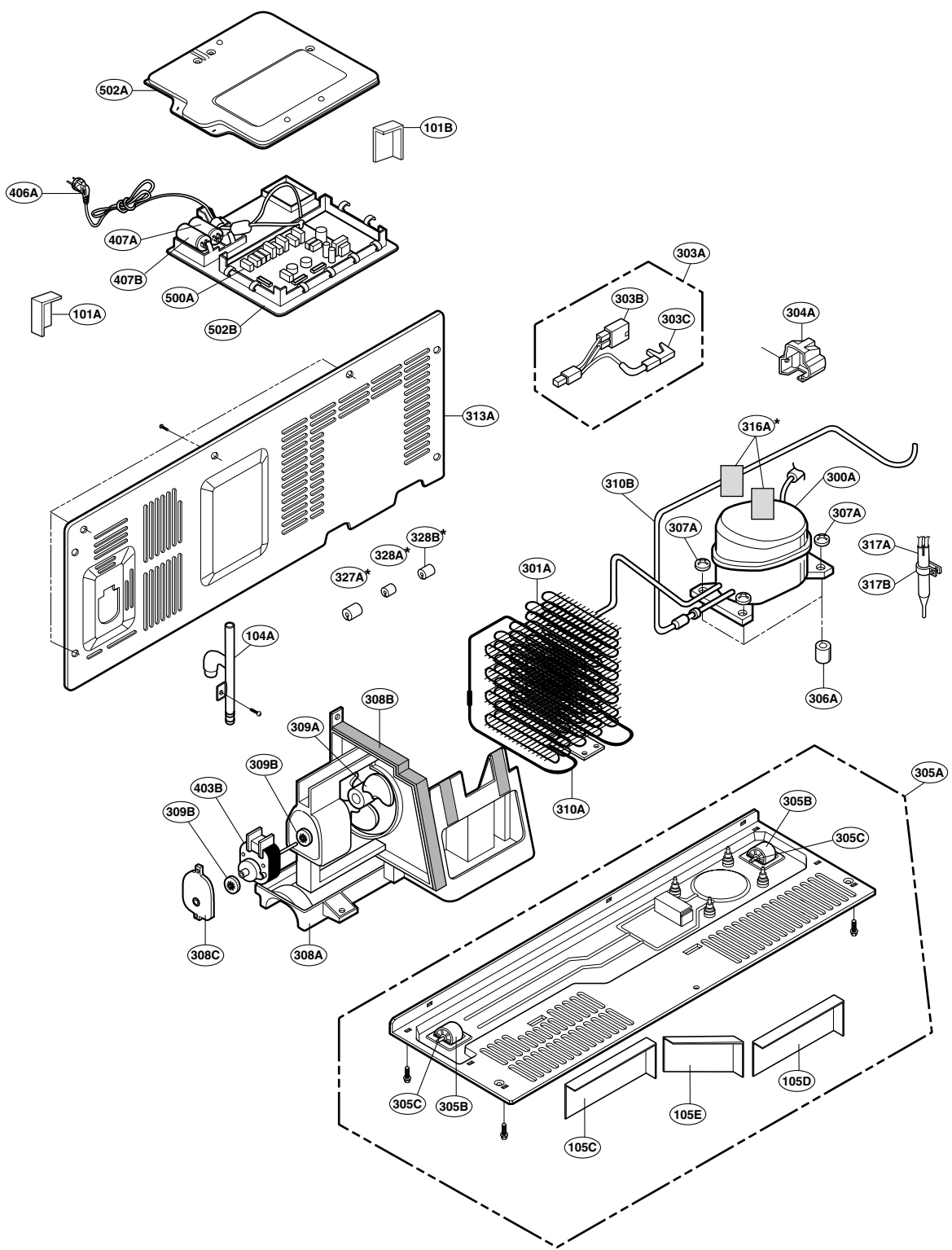

EXPLODED VIEW

DISPEDNSER PART: LSC26905TT (Refer to appendix)

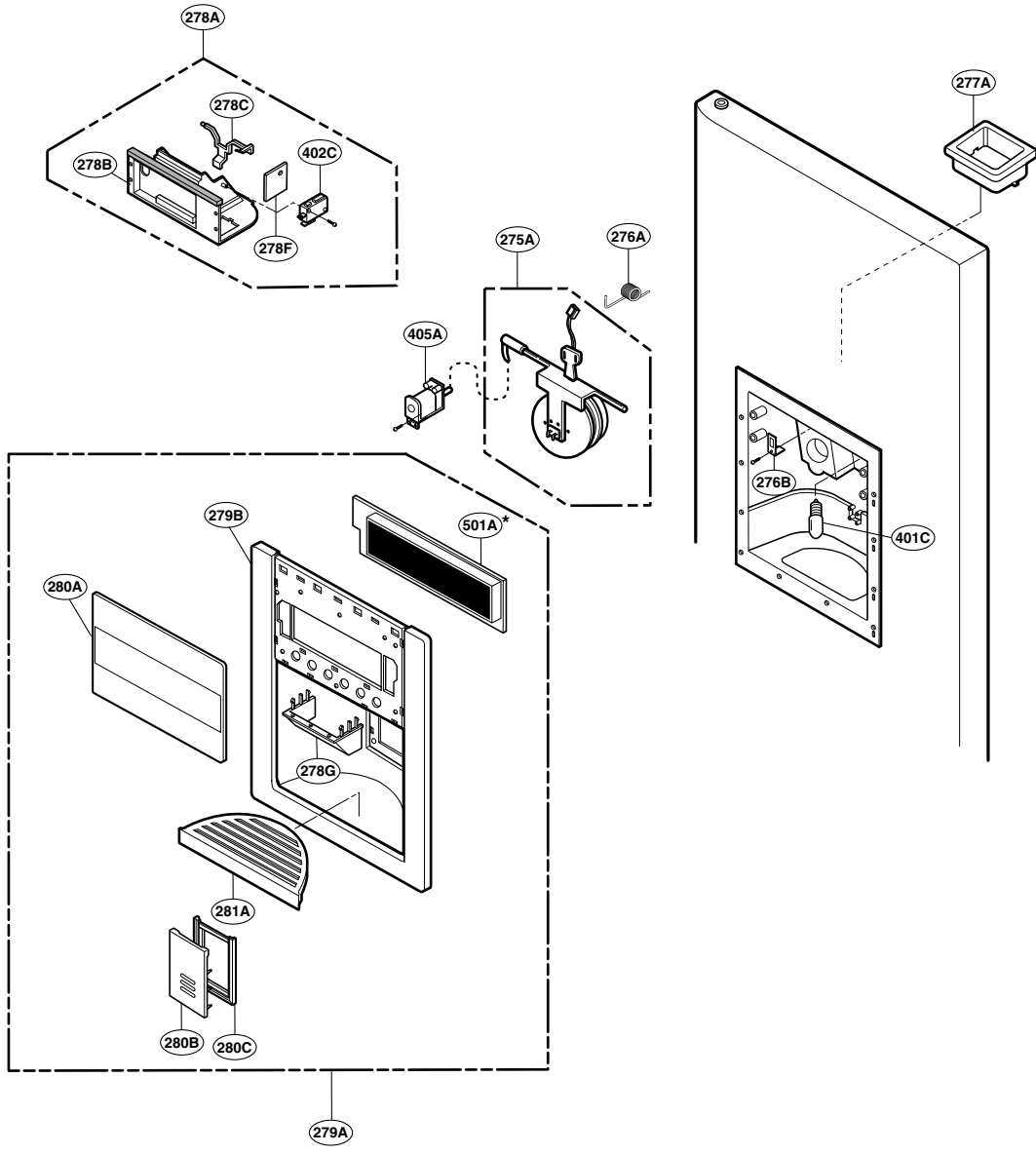



P/No. 3828JD8797C

JULY., 2005 Printed in Korea