



LG

REFRIGERATOR

SERVICE MANUAL

CAUTION
BEFORE SERVICING THE UNIT,
READ THE SAFETY PRECAUTIONS IN THIS MANUAL.

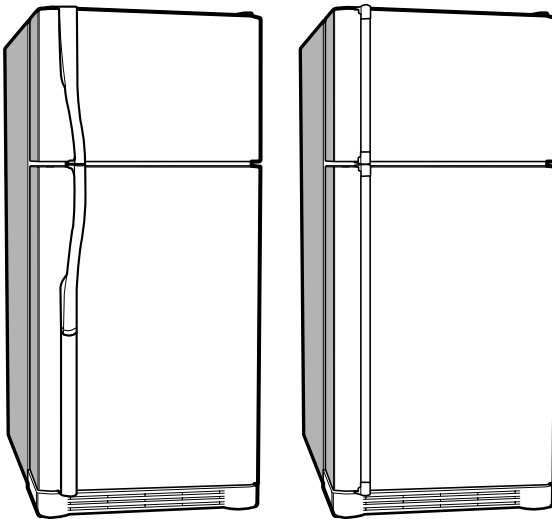

models

LRTN22330**

LRTN22320**

LRTN19330**

LRTN19320**

CONTENTS

SAFETY PRECAUTIONS	2
SPECIFICATIONS	3
PARTS IDENTIFICATION	4
DISASSEMBLY	5-6
DOOR.....	5
DOOR SWITCH.....	5
FAN AND FAN MOTOR.....	6
DEFROST CONTROL ASSEMBLY.....	6
LAMP.....	6
CONTROL BOX-REFRIGERATOR.....	6
ADJUSTMENT	7-8
COMPRESSOR.....	7
PTC-STARTER.....	7
OLP (OVERLOAD PROTECTOR)	8
TO REMOVE THE COVER PTC.....	8
CIRCUIT DIAGRAM	9-10
TROUBLESHOOTING	11-16
COMPRESSOR AND ELECTRICAL COMPONENTS	11
PTC AND OLP.....	12
OTHER ELECTRICAL COMPONENTS	13
SERVICE DIAGNOSIS CHART.....	14
REFRIGERATION CYCLE	15-16
OPERATION PRINCIPLE & REPAIR METHOD OF ICEMAKER	17-20
DESCRIPTION OF FUNCTION & CIRCUIT OF MICOM	21-33
EXPLODED VIEW & REPLACEMENT PARTS LIST	34-39

SAFETY PRECAUTIONS

Please read the following instructions before servicing your refrigerator.

1. Check the refrigerator for electrical faults.
2. To prevent electric shock, unplug before servicing.
3. Always check line voltage and amperage.
4. Use standard electrical components or cause your skin to freeze and stick to the surfaces inside the freezer.
5. Don't touch metal products in the freezer with wet hands. This may cause frostbite.
6. Prevent water from spilling onto electric elements or the machine parts.
7. Close the top door before opening the bottom door. Otherwise, you might hit your head when you stand up.
8. When tilting the refrigerator, remove any materials on the refrigerator, especially the glass shelves and stored food.
9. When servicing the evaporator, wear cotton gloves. This is to prevent injuries from the sharp evaporator fins.
10. Service on the refrigerator should be performed by a qualified technician. Sealed system repair must be performed by a CFC certified technician.

1. SPECIFICATIONS

1-1 DISCONNECT POWER CORD BEFORE SERVICING IMPORTANT – RECONNECT ALL GROUNDING DEVICES

All parts of this appliance capable of conducting electrical current are grounded. If grounding wires, screws, straps, clips, nuts or washers used to complete a path to ground are removed for service, they must be returned to their original position and properly fastened.

1-2 IMPORTANT NOTICE

This information is intended for use by individuals possessing adequate backgrounds of electrical, electronic and mechanical experience. Any attempt to repair a major appliance may result in personal injury and property damage. The manufacturer or seller cannot be responsible for the interpretation of this information, nor can it assume any liability in connection with its use.

1-3 ELECTRICAL SPECIFICATIONS

Temperature Control (Position : MID)	8-(-6)°F
Defrost Control	7 hrs.
Defrost Thermostat	50°F
Electrical Rating :115V. AC, 60 Hz.	1-5 Amp.
Maximum Current Leakage	0.5 mA
Maximum Ground Path Resistance	0.14 Ohms
Energy Consumption	19 cu.ft : 443 kWh/yr(Energy star)
	22 cu.ft : 468 kWh/yr(Energy star)

1-4 NO LOAD PERFORMANCE CONTROL POSITION: MID/MID

And Ambient Temp:	70°F	90°F
Fresh Food, °F	33-41	33-41
Frozen Food, °F	(-4)-4	(-4)-4
Percent Running Time	25-35	45-60

1-5 REFRIGERATION SYSTEM

Minimum Compressor Capacity Vacuum	21 in.
Minimum Equalized Pressure	
@ 70°F	49 PSIG
@ 90°F	56 PSIG
Refrigerant - R - 134a	5.47 oz.
Compressor	649 BTU/hr

1-6 INSTALLATION

Clearance must be provided at top, sides and rear of the refrigerator for air circulation.

AT TOP	1 in
AT SIDES	1/8 in
AT REAR	1 in

1-7 REPLACEMENT PARTS

Relay	6748C-0004D
Overload	6750C-0004S
Defrost Thermostat	6615JB2005B
Defrost Heater	19cu. ft : 5300JK1003D
	22cu. ft : 5300JK1003J
Evaporator Fan Motor	4681JB1016J
Capacitor	OCZZJB2003H
Compressor (Hi-Side)	2521C-A62A8
Evaporator (Lo-Side)	19cu. ft : 5421JJ0003A
	22cu. ft : 5421JJ0002A
Condenser	5403JJ1003A
Dryer	5851JJ2002K
Condenser Fan Motor	4681JK1001B
Temperature Control	6871JB2043A,B
Main Control	6871JB1185A

1-8 AIR FLOW / CIRCULATION D'AIR

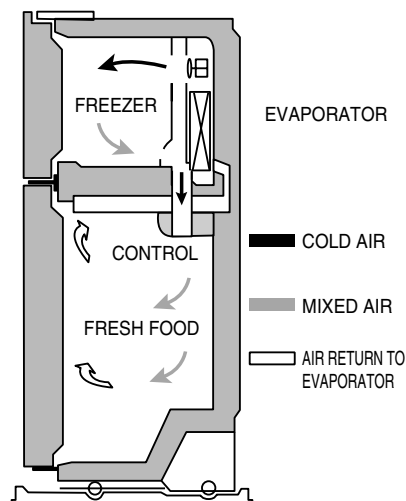
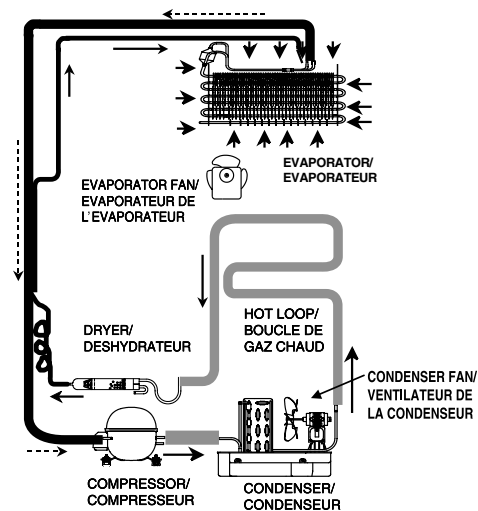

2. PARTS IDENTIFICATION

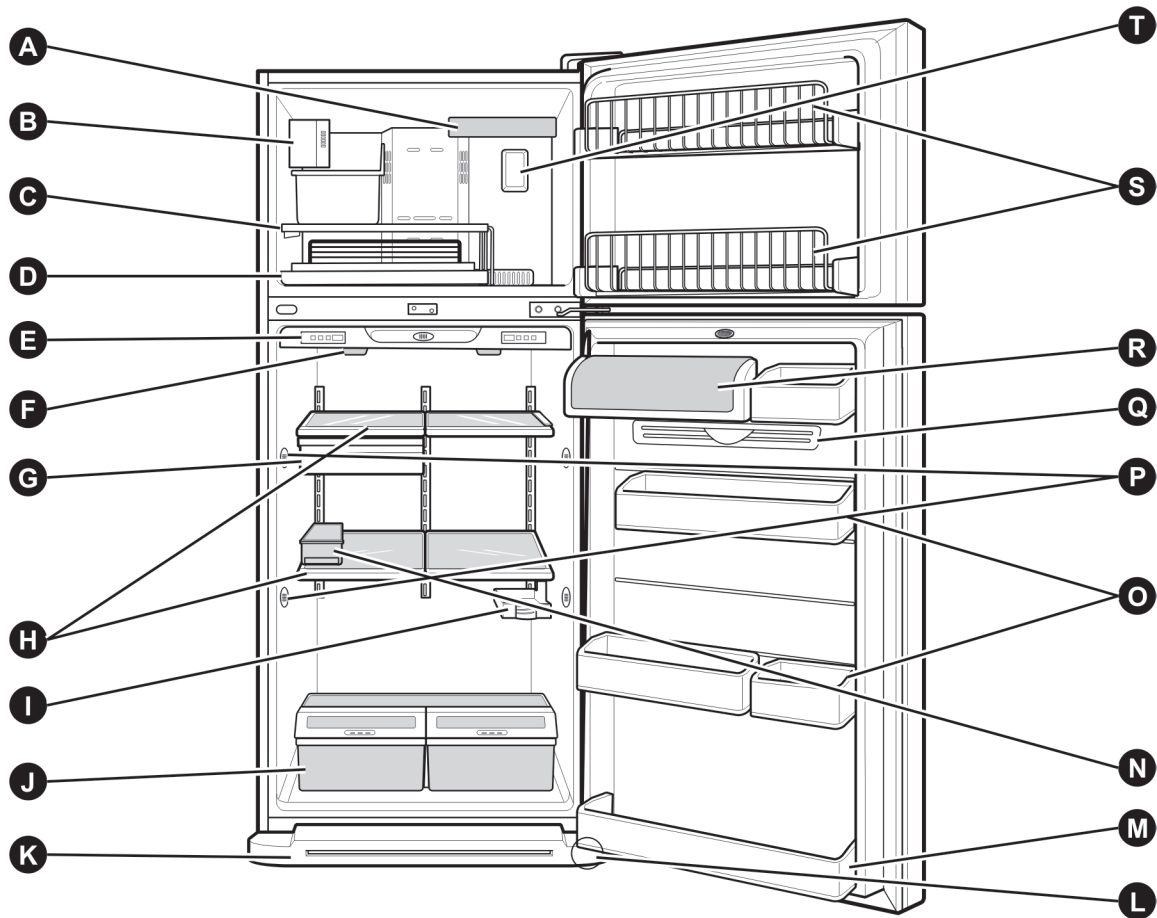

A Pizza Nook*

B CustomCube Ice maker *

C CustomFit

D FlexiFloor *

E Digital Sensor Control

F Refrigerator Light *

G Chef Fresh * / Snack Pan

H Shelves

I Can Dispenser*

J OptiBin Crisper

K Base Grille

L Leveling Screw (inside)

M Refrigerator Door Bin

N Egg Box*

O Design-A-Door

P Icebeam Door Cooling *

Q Door Cooling

R Dairy Bin

S Freezer Door Bin *

T Freezer Light

* on some models

3. DISASSEMBLY

3-1 DOOR

● Freezer Door

1. Remove the hinge cover by pulling it upwards.
2. Loosen hexagonal bolts attaching the upper hinge to the body and lift the freezer door.

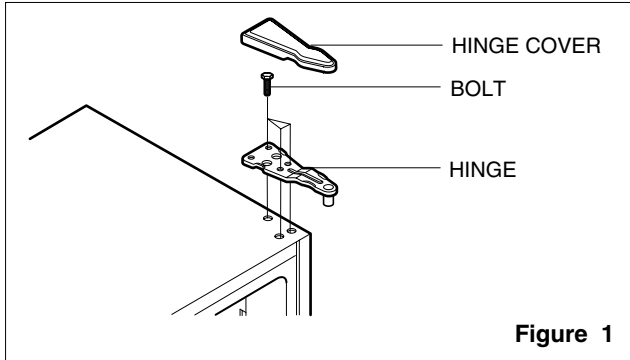

3. Pull out the door gasket to remove from the door foam assembly.

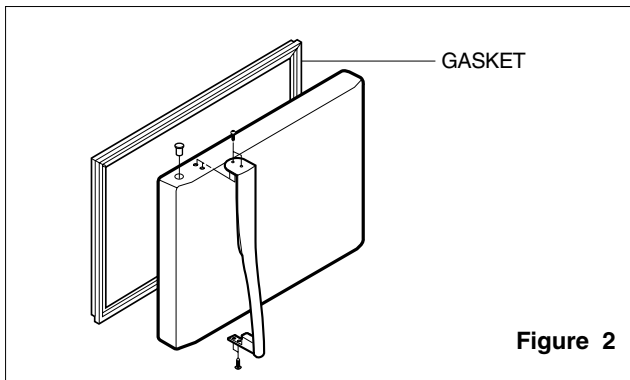

● Refrigerator Door

1. Loosen hexagonal bolts attaching the lower hinge to the body to remove the refrigerator door only.

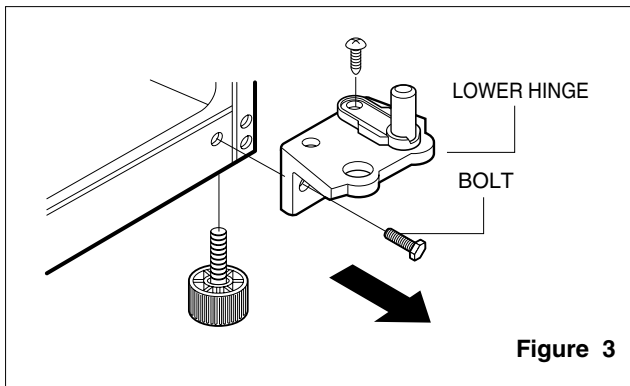

2. Pull out the door gasket to remove from the door foam assembly.

3-2 DOOR SWITCH

1. To remove the door switch, pry it out with a slotted-type driver, as shown in (Figure 4).
2. Disconnect the lead wire from the switch.

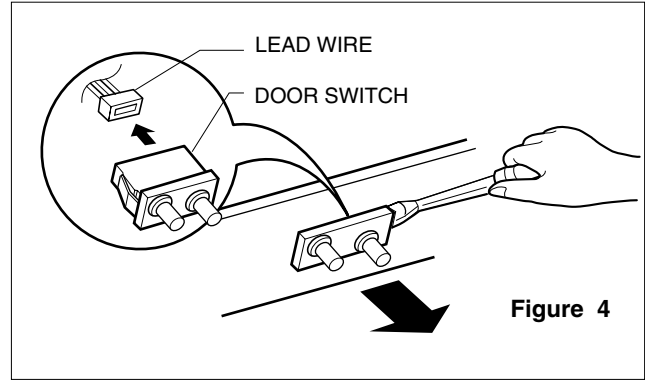

3-3 FAN AND FAN MOTOR

1. Remove the freezer shelf. (If your refrigerator has an icemaker, remove the icemaker first)
2. Remove the grille by pulling it out and by loosening a screw.
3. Remove the Fan Motor assembly by loosening 4 screws and disassemble the shroud.
4. Pull out the fan and separate the Fan Motor and Bracket.

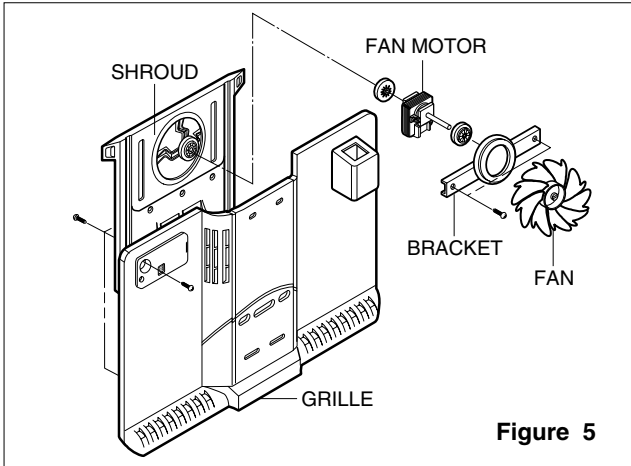

3-4 DEFROST CONTROL ASSEMBLY

Defrost Control assembly consists of Defrost Sensor and FUSE-M.

Defrost sensor functions to defrost automatically. It is attached to metal side of the Evaporator and senses Temperature. At the temperature of 162°F(72°C), it stops the emission of heat from the Heater.

Fuse-M is a safety device for preventing over-heating of the Heater when defrosting.

1. Pull out the grille assembly (Figure 6)
2. Separate the connector from the Defrost Control assembly and replace the Defrost Control assembly after cutting the Tie Wrap. (Figure 7)

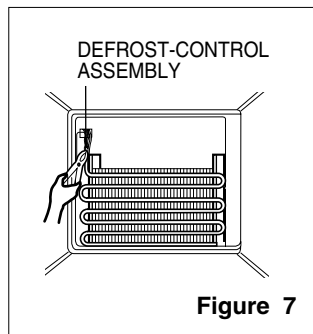
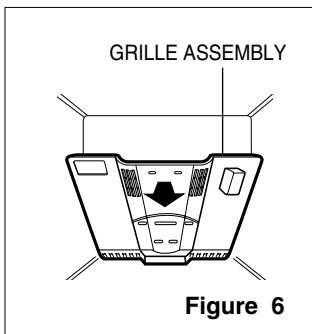

3-5 LAMP

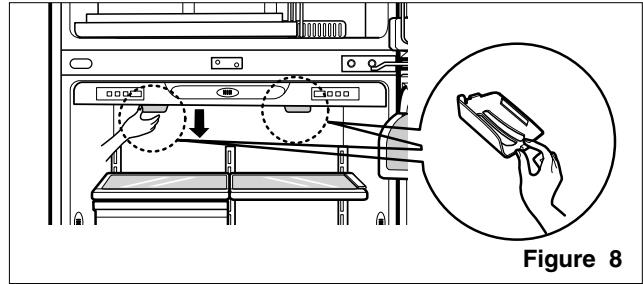

3-5-1 Refrigerator Compartment Lamp

1. Unplug the power cord from the outlet.
2. Remove refrigerator shelves.
3. Release the hooks on both ends of the lamp shield and pull the shield downward to remove it.
4. Turn the lamp counterclockwise.
5. Assemble in reverse order of disassembly. Replacement bulb must be the same specification as the original (Max. 60 W-2EA).

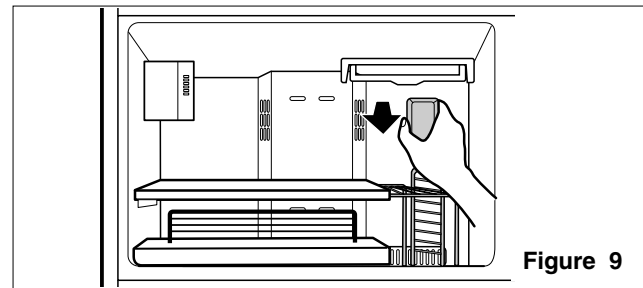

3-5-2 Freezer Compartment Lamp

1. Unplug refrigerator or disconnect power.
2. Reach behind light shield to remove bulb.
3. Replace bulb with a 40-watt appliance bulb.
4. Plug in refrigerator or reconnect power.

3-6 CONTROL BOX-REFRIGERATOR

1. First, remove all shelves in the refrigerator. Then remove the Refrigerator Control Box by loosening 2 screws.

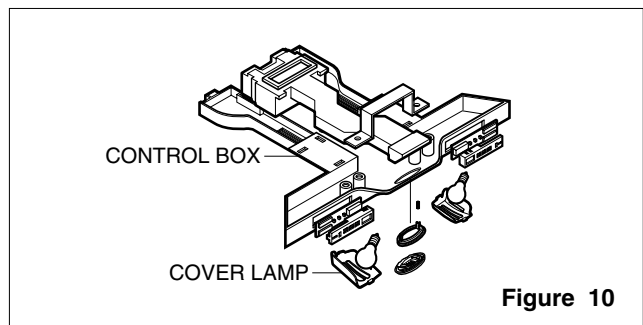

2. Remove the Refrigerator Control Box by pulling it downward.
3. Disconnect the lead wire on the right position and separate the lamp sockets.

4. ADJUSTMENT

4-1 COMPRESSOR

4-1-1 Role

The compressor intakes low temperature and low pressure gas from the evaporator of the refrigerator and compresses this gas to high-temperature and high-pressure gas. It then delivers the gas to the condenser.

4-1-2 Composition

The compressor includes overload protection. The PTC starter and OLP (overload protector) are attached to the outside of the compressor. Since the compressor is manufactured to tolerances of 1 micron and is hermetically sealed in a dust and moisture-free environment, use extreme caution when repairing it.

4-1-3 Note for Usage

- (1) Be careful not to allow over-voltage and over-current.
- (2) If compressor is dropped or handled carelessly, poor operation and noise may result.
- (3) Use proper electric components appropriate to the Particular Compressor in your product.
- (4) Keep Compressor dry.
If Compressor gets wet (in the rain or a damp environment) and rust forms in the pin of the Hermetic Terminal, poor operation and contact may result.
- (5) When replacing the Compressor, be careful that dust, humidity, and soldering flux don't contaminate the inside of the compressor. Dust, humidity, and solder flux contaminate the cylinder and may cause noise or improper operation even cause it to lock up.



4-2 PTC-STARTER

4-2-1 Composition of PTC-Starter

- (1) PTC (Positive Temperature Coefficient) is a no-contact semiconductor starting device which uses ceramic material consisting of BaTiO₃.
- (2) The higher the temperature is, the higher the resistance value. These features are used as a starting device for the Motor.

4-2-2 Role of PTC-Starter

- (1) The PTC is attached to the Sealed Compressor and is used for starting the Motor.
- (2) The compressor is a single-phase induction motor. During the starting operation, the PTC allows current flow to both the start winding and main winding.

4-2-3 PTC-Applied Circuit Diagram

● Starting Method for the Motor

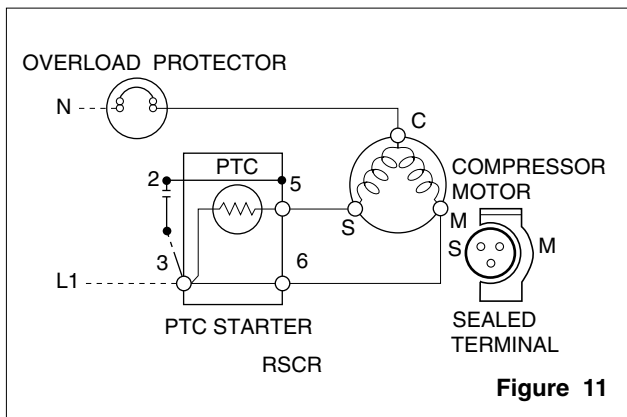

4-2-4 Motor Restarting and PTC Cooling

- (1) It requires approximately 5 minutes for the pressure to equalize before the compressor can start.
- (2) The PTC device generates heat during operation. Therefore, it must be allowed to cool before the compressor can restart.

4-2-5 Relation of PTC-Starter and OLP

- (1) If the compressor attempts to restart before the PTC device is cooled, the PTC device will allow current to flow only to the main winding.
- (2) The OLP will open because of the over current condition. This same process will continue (3 to 5 times) when the compressor attempts to restart until the PTC device has cooled. The correct OLP must be properly attached to prevent damage to the compressor.

4-2-6 Note for Using the PTC-Starter

- (1) Be careful not to allow over-voltage and over-current.
- (2) Do not drop or handle carelessly.
- (3) Keep away from any liquid.
If liquid such as oil or water enters the PTC, PTC materials may fail due to breakdown of their insulating capabilities.
- (4) If the exterior of the PTC is damaged, the resistance value may be altered. This can cause damage to the compressor and result in a no-start or hard-to-start condition.
- (5) Always use the PTC designed for the compressor and make sure it is properly attached to the compressor.

4-3 OLP (OVERLOAD PROTECTOR)

4-3-1 Definition of OLP

- (1) OLP (OVERLOAD PROTECTOR) is attached to the Compressor and protects the Motor by opening the circuit to the Motor if the temperature rises and activating the bimetal spring in the OLP.
- (2) When high current flows to the Compressor motor, the Bimetal works by heating the heater inside the OLP, and the OLP protects the Motor by cutting off the current flowing to the Compressor Motor.

4-3-2 Role of the OLP

- (1) The OLP is attached to the Sealed Compressor used for the Refrigerator. It prevents the Motor Coil from being started in the Compressor.
- (2) For normal operation of the OLP, do not turn the Adjust Screw of the OLP in any way.

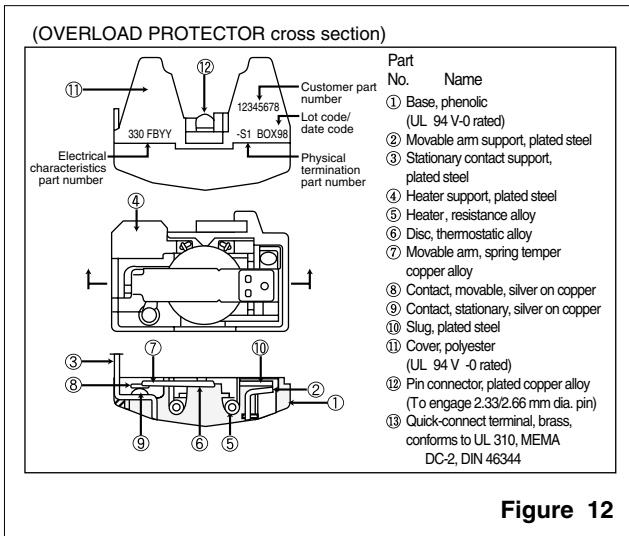
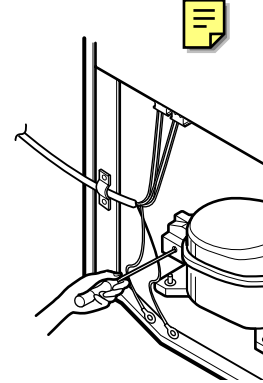

Figure 12

4-4 TO REMOVE THE COVER PTC



1) Remove the Cover PTC Back M/C.

(2) Remove the screw on Cover PTC.

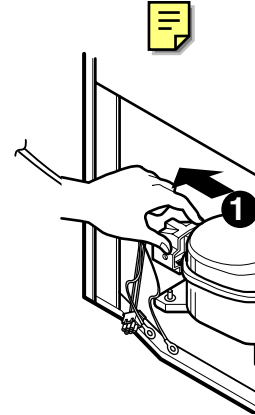

(3) Remove two Housings on upper part of Cover PTC.

(4) Take out the cover PTC from upper to lower position like ①.

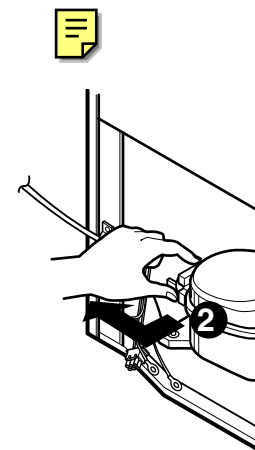

(5) Turn 45° in the direction of ② and take it out.

(6) Assembly in reverse order of disassembly.

5. CIRCUIT DIAGRAM

BEST MODEL

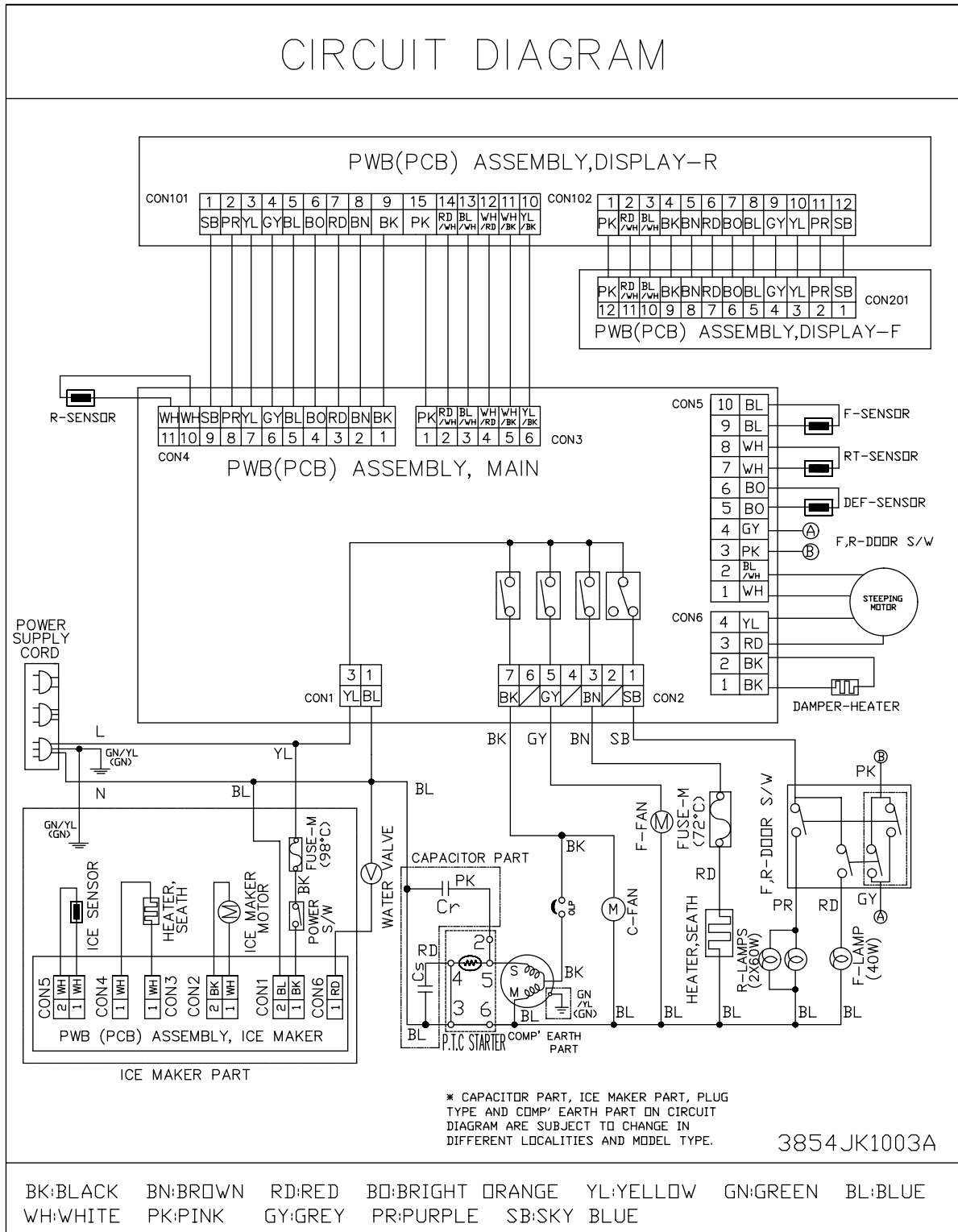

BETTER MODEL

CIRCUIT DIAGRAM

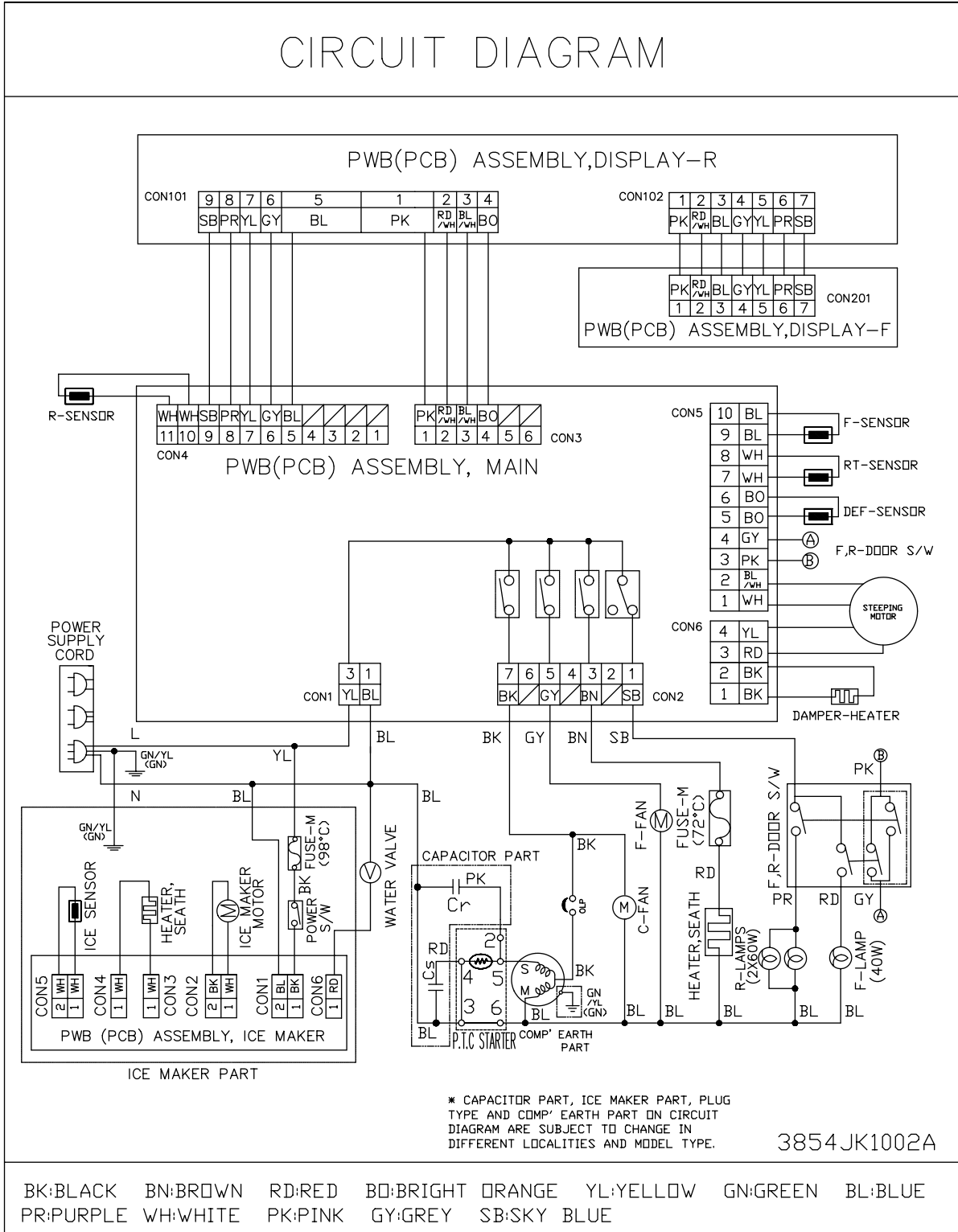

6. TROUBLESHOOTING

6-1 COMPRESSOR AND ELECTRIC COMPONENTS

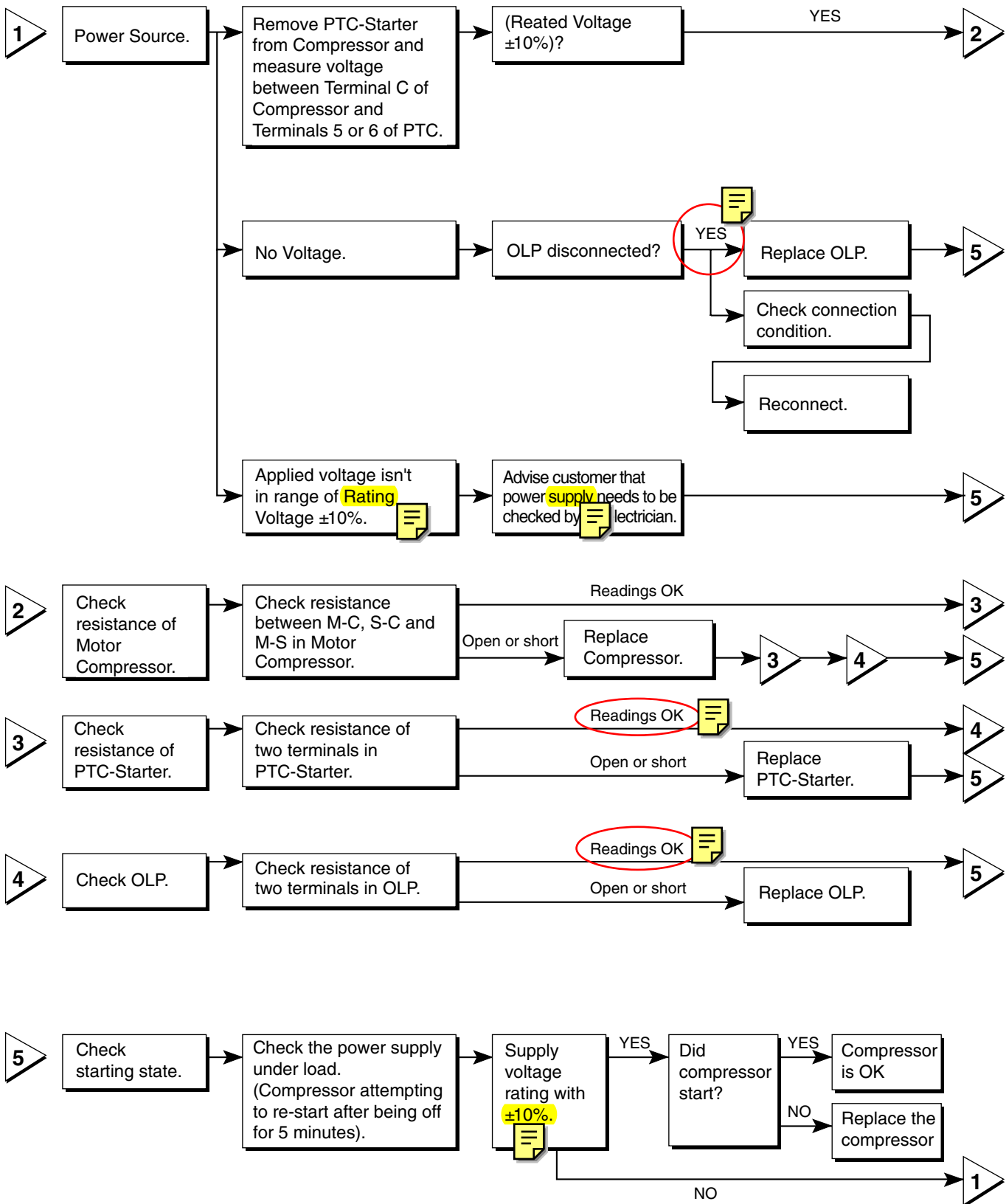

6-2 PTC AND OLP

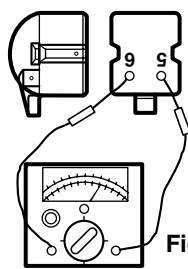
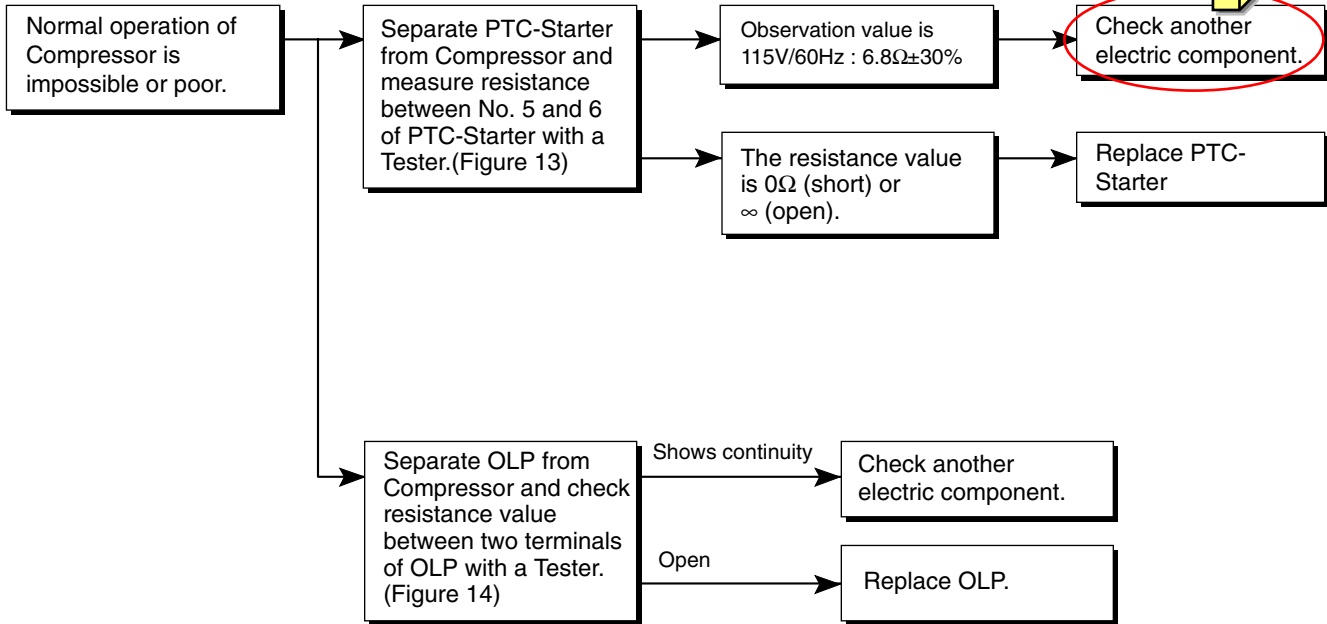

Figure 13

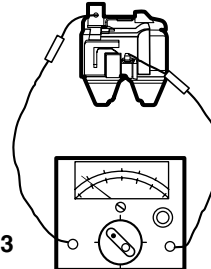
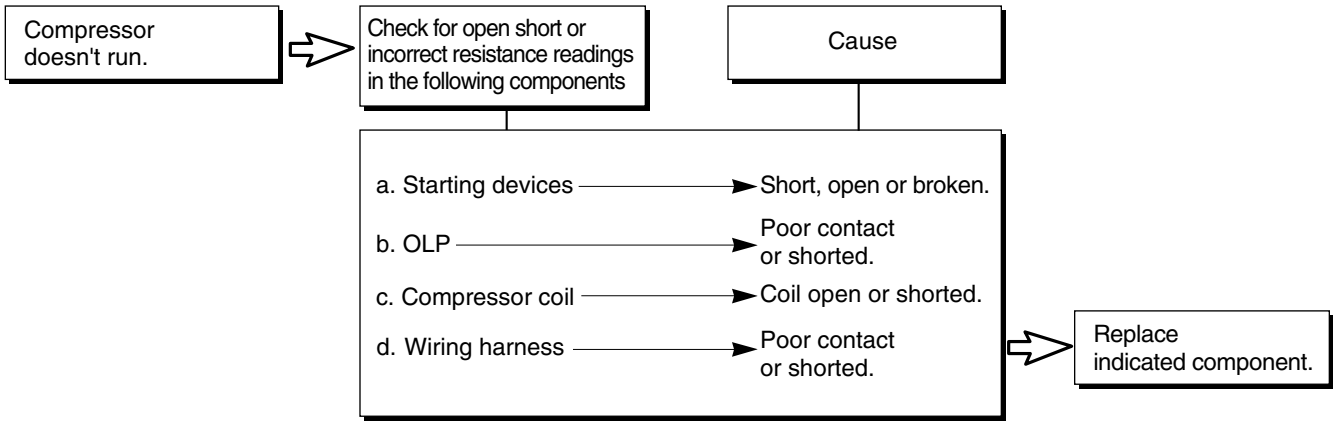

Figure 14

6-3 OTHER ELECTRIC COMPONENTS

▼ Not cooling at all



▼ Poor cooling performance

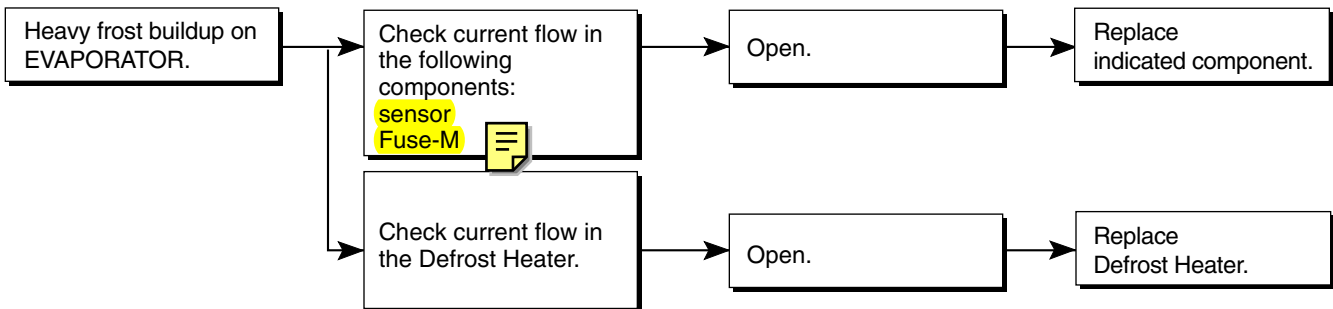
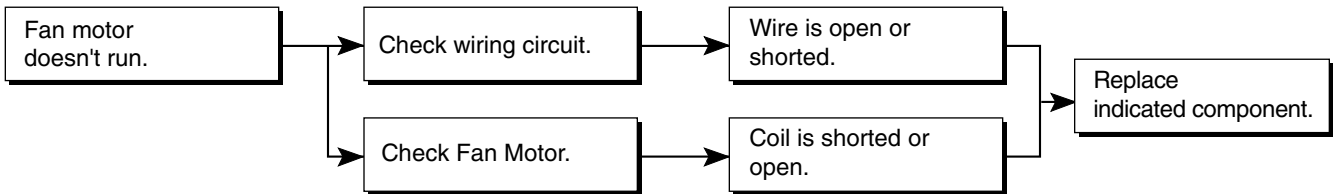
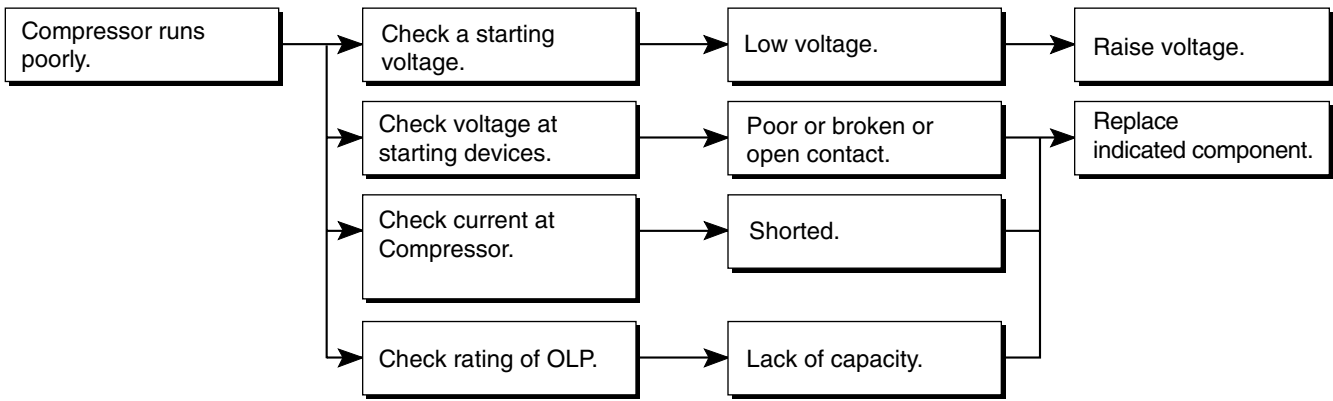

6-4 SERVICE DIAGNOSIS CHART

COMPLAINT	POINTS TO BE CHECKED	REMEDY
No Cooling.	<ul style="list-style-type: none"> • Is the power cord unplugged from the outlet? • Check if the power Switch is set to OFF. • Check if the fuse of the power Switch is shorted. • Measure the voltage of the power outlet. 	<ul style="list-style-type: none"> • Plug into the outlet. • Set the switch to ON. • Replace the fuse. • If the voltage is low, correct the wiring.
Cools poorly.	<ul style="list-style-type: none"> • Check if the unit is placed too close to the wall. • Check if the unit is placed too close to the stove, gas cooker, or in direct sunlight. • Is the ambient temperature too high or the room door closed? • Check if food put in the refrigerator is hot. • Did you open the door of the unit too often or check if the door is sealed properly? • Check if the Control is set to Warm position. 	<ul style="list-style-type: none"> • Place the unit about 10 cm from the wall. • Place the unit away from these heat sources. • Lower the ambient temperature. • Put in foods after they have cooled down. • Don't open the door too often and close it firmly. • Set the control to Recommended-position.
Foods in the Refrigerator are frozen.	<ul style="list-style-type: none"> • Is food placed in the cooling air outlet? • Check if the control is set to colder-position. • Is the ambient temperature below 41°F(5°C)? 	<ul style="list-style-type: none"> • Place foods in the high-temperature section. (front part) • Set the control to Recommended-position. • Set the control to Warm-position.
Condensation or ice forms inside the unit.	<ul style="list-style-type: none"> • Is liquid food sealed? • Check if food put in the refrigerator is hot. • Did you open the door of the unit too often or check if the door is sealed properly? 	<ul style="list-style-type: none"> • Seal liquid foods with wrap. • Put in foods after they have cooled down. • Don't open the door too often and close it firmly.
Condensation forms in the Exterior Case.	<ul style="list-style-type: none"> • Check if the ambient temperature and humidity of the surrounding air are high. • Is there a gap in the door gasket? 	<ul style="list-style-type: none"> • Wipe moisture with a dry cloth. It will disappear in low temperature and humidity. • Fill up the gap.
There is abnormal noise.	<ul style="list-style-type: none"> • Is the unit positioned in a firm and even place? • Are any unnecessary objects placed in the back side of the unit? • Check if the Drip Tray is not firmly fixed. • Check if the cover of the compressor enclosure in the lower front side is taken out. 	<ul style="list-style-type: none"> • Adjust the Leveling Screw, and position in a firm place. • Remove the objects. • Fix the Drip Tray firmly in the original position. • Place the cover in its original position.
Door does not close well.	<ul style="list-style-type: none"> • Check if the door gasket is dirty with an item like juice. • Is the refrigerator level? • Is there too much food in the refrigerator? 	<ul style="list-style-type: none"> • Clean the door gasket. • Position in the firm place and level the Leveling Screw. • Make sure food stored in shelves does not prevent the door from closing.
Ice and foods smell unpleasant	<ul style="list-style-type: none"> • Check if the inside of the unit is dirty. • Are foods with a strong odor unwrapped? • The unit smells of plastic. 	<ul style="list-style-type: none"> • Clean the inside of the unit. • Wrap foods that have a strong odor. • New products smell of plastic, but this will go away after 1-2 weeks.

● Other possible problems:

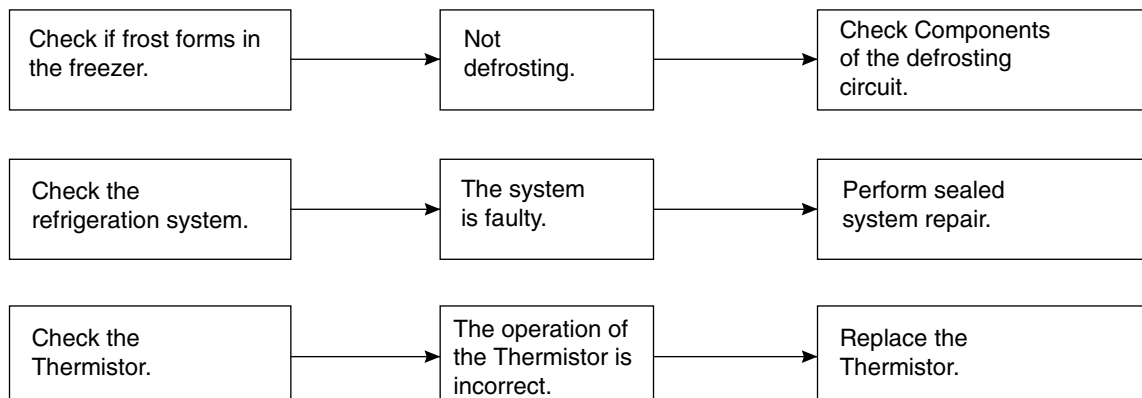

6-5 REFRIGERATING CYCLE

▼ Troubleshooting Chart



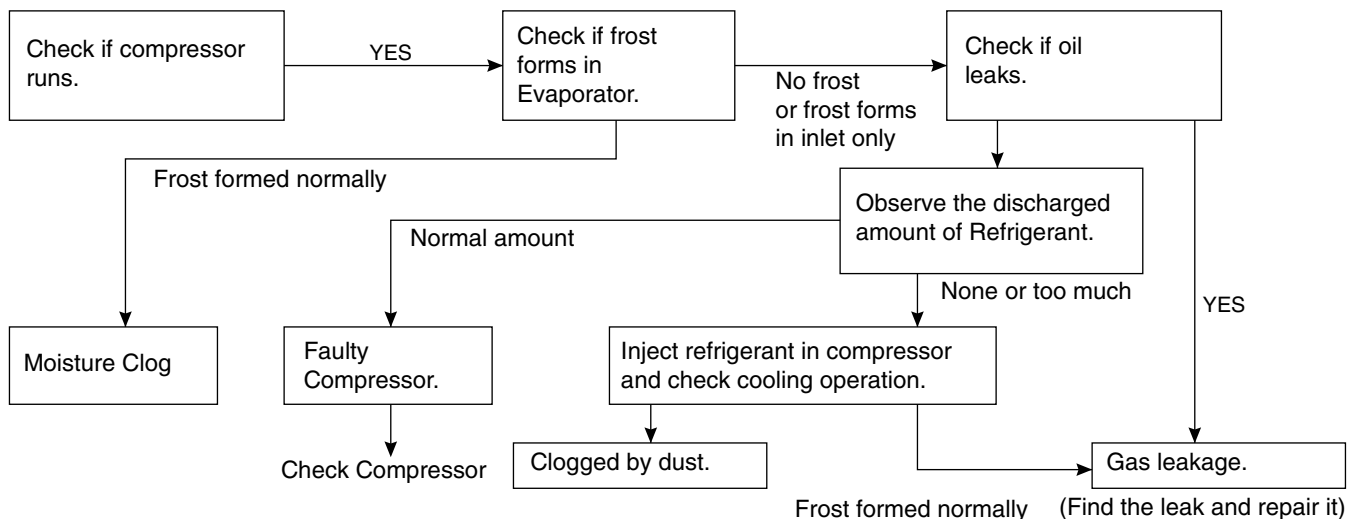

CAUSE		STATE OF THE UNIT	STATE OF THE EVAPORATOR	TEMPERATURE OF THE COMPRESSOR	REMARKS
LEAKAGE	PARTIAL LEAKAGE	Freezer compartment and Refrigerator don't cool normally.	Low flowing sound of Refrigerant is heard and frost forms in inlet only.	A little higher than ambient temperature.	<ul style="list-style-type: none"> Refrigerant level is low due to a leak. Normal cooling is possible by restoring the normal amount of refrigerant and repairing the leak.
	COMPLETE LEAKAGE	Freezer compartment and Refrigerator don't cool normally.	Flowing sound of refrigerant is not heard and frost isn't formed.	Equal to ambient temperature.	<ul style="list-style-type: none"> No discharging of Refrigerant. Normal cooling is possible by restoring the normal amount of refrigerant and repairing the leak.
RESTRICTED BY DUST	PARTIAL RESTRICTION	Freezer compartment and Refrigerator don't cool normally.	Flowing sound of refrigerant is heard and frost forms in inlet only.	A little higher than ambient temperature.	<ul style="list-style-type: none"> Normal discharging of the refrigerant. The capillary tube is faulty.
	WHOLE RESTRICTION	Freezer compartment and Refrigerator don't cool.	Flowing sound of refrigerant is not heard and frost isn't formed.	Equal to ambient temperature.	<ul style="list-style-type: none"> Normal discharging of the Refrigerant.
MOISTURE RESTRICTION		Cooling operation stops periodically.	Flowing sound of refrigerant is not heard and frost melts.	Lower than ambient temperature.	<ul style="list-style-type: none"> Cooling operation restarts when heating the inlet of the capillary tube.
DEFECTIVE COMPRESSION	COMP-RESSION	Freezer and Refrigerator don't cool.	Low flowing sound of refrigerant is heard and frost forms in inlet only.	A little higher ambient temperature.	<ul style="list-style-type: none"> Low pressure at high side of compressor due to low refrigerant level.
	NO COMP-RESSION	No compressing operation.	Flowing sound of refrigerant is not heard and there is no frost.	Equal to ambient temperature.	<ul style="list-style-type: none"> No pressure in the high pressure part of the compressor.

▼ Leakage Detection

- Observe the discharging point of the refrigerant, which may be in the oil discharging part of the compressor and in a hole in the evaporator.



▼ General Control of Refrigerating Cycle

NO.	ITEMS	UNIT	STANDARDS	PURPOSES	REMARKS	
1	Pipe and piping system opening time	Min.	Pipe: within 1 hour. Comp: within 10 minutes. Drier: within 20 minutes.	To protect moisture penetration 	The opening time should be reduced to a half of the standards during rain and rainy seasons (the penetration of water into the pipe is dangerous).	
2	Welding	Nitrogen pressure	Weld under Nitrogen atmosphere. (N ₂ pressure: 0.1~0.2 kg/cm ²)	To protect oxide scale formation.	<ul style="list-style-type: none"> - Refer to repair note in each part. - R-134a refrigerant is more susceptible to leaks than R-12 and requires more care during welding. - Do not apply force to pipes before and after welding to protect pipe from cracking. 	
3	N ₂ sealed parts	Confirm N ₂ leak	Confirm the sound of pressure relief when removing the rubber cap. Sound: usable No sound: not usable	To protect moisture penetration 	<ul style="list-style-type: none"> - In case of evaporator parts, if it doesn't make sound when removing rubber cap, blow dry air or N₂ gas for more than 1 min. and than use the parts.  	
4	Refrigeration Cycle	Evacuation time	Min.	More than 40 minutes	To remove moisture.	Note: Only applicable to the model equipped with reverse flow protect plate.
		Vacuum degree	Torr	Below 0.03 (ref)		
		Vacuum	EA	High and low pressure sides are evacuated at the same time for models above 200 l.		Vacuum efficiency can be improved by operating compressor during evacuation.
		Vacuum piping	EA	Use R-134a manifold exclusively.	To protect mixing of mineral and ester oils.	The rubber pipes for R-12 refrigerant will be melted when they are used for R-134a refrigerant (causes of leak.)
		Pipe coupler	EA	Use R-134a manifold exclusively.	To protect R-12 refrigerant mixing.	
		Outlet (Socket)		R-134a manifold exclusively.	To protect R-12 refrigerant mixing.	
		Plug		R-134a manifold exclusively.	To protect R-12 refrigerant mixing.	
5	Refrigerant weighing	EA	Use R-134a exclusively. Weighing allowance: ±5g Note: Winter: -5g Summer: +5g	Do not mix with R-12 refrigerant.	<ul style="list-style-type: none"> - Do not weigh the refrigerant at too hot or too cold an area. (77°F [25°C] is adequate.) - Make Copper charging canister (Device filling refrigerant) Socket: 2SV Plug: 2PV R-134a Note: Do not burn O-ring (bushing) during welding. 	
6	Drier replacement		<ul style="list-style-type: none"> - Use R-134a exclusively for R-134a refrigerator. - Replace drier whenever repairing refrigerator cycle piping. 	To remove the moisture from pipe inside.		
7	Leak check 		<ul style="list-style-type: none"> - Do not use soapy water for check. It may be sucked into the pipe by a vacuum. 	Defect in refrigerant leak area.	<ul style="list-style-type: none"> - Check for an oil leak at the refrigerant leak area. Use an electronic leak detector if an oil leak is not found. - The electronic leak detector is very sensitive to halogen gas in the air. It also can detect R-141b in urethane. Practice many times before using this type of detector to avoid false readings. 	

7. OPERATION PRINCIPLE AND REPAIR METHOD OF ICE MAKER

7-1 OPERATION PRINCIPLE

7-1-1 Operation Principle of Icemaker

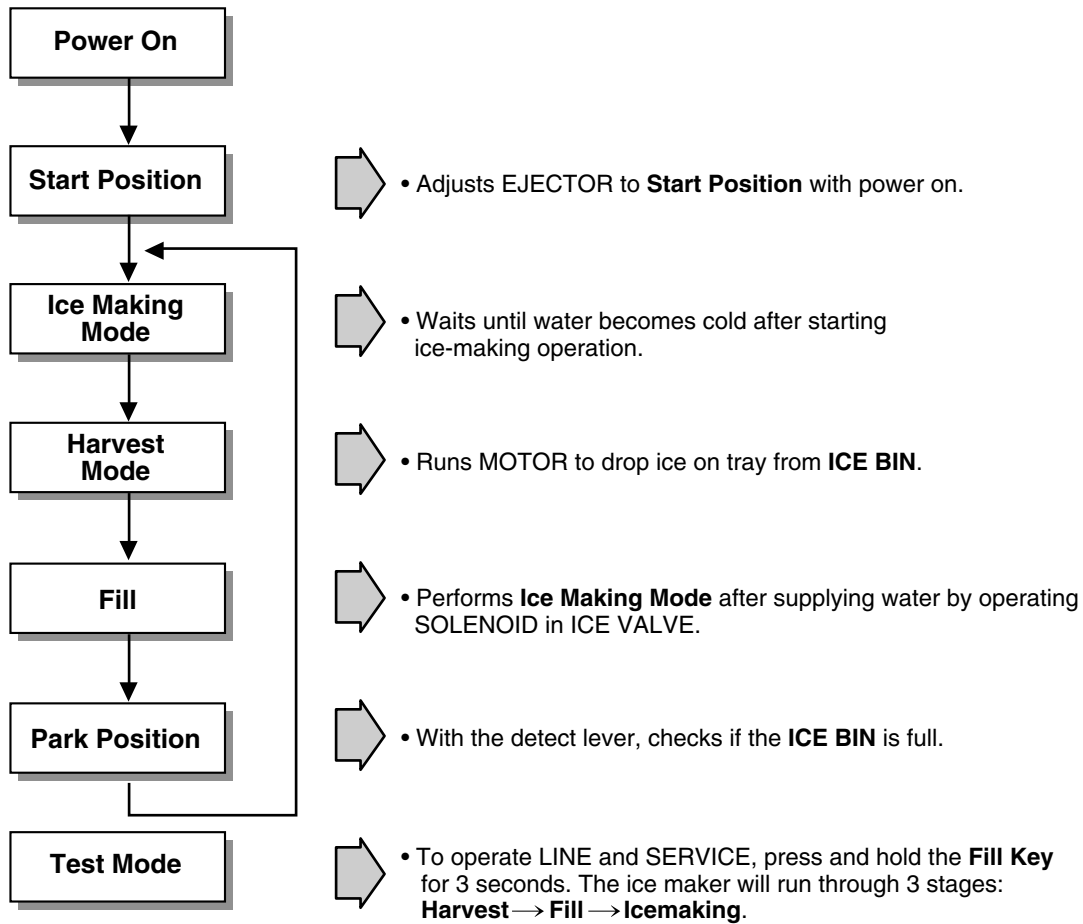

1. Turning the icemaking stop switch off (O) stops the icemaking function.
2. Setting the icemaker switch to OFF and then turning it back on will reset the icemaker control.

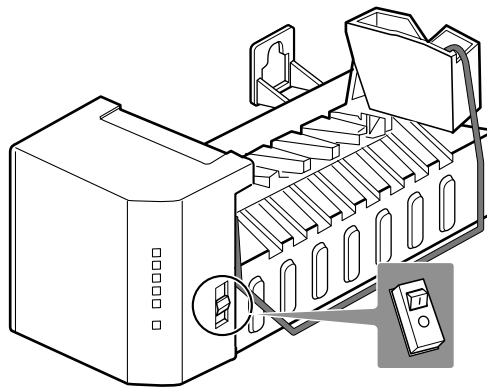

7-2 CONTROL METHOD ACCORDING TO FUNCTIONS

7-2-1 Start Position

1. After POWER OFF or Power Cut, check EJECTOR's position with MICOM initialization to restart.
2. Control Method to check if it's in place:
 - (1) EJECTOR is in place,
 - The ejector must be in the park position before a new cycle can be initiated.
 - (2) EJECTOR isn't in place:
 - A. If there is no ice formed in the ice maker, it should take approximately 2 minutes for the ejector blades to cycle through the harvest mode and return to the park position.
 - B. If there is ice formed in the ice maker, it can take up to 18 minutes for the ejector blades to cycle through the harvest mode and return to the park position.

7-2-2 Ice Making Mode

1. The Ice Making Mode starts once the ejector is in the park position and the ice maker mold is filled with water.
2. The Ice Making Mode is terminated when the ice maker sensor reaches 19°F(-7°C). This may take between 1 and 4 hours.

7-2-3 Harvest Mode

1. The Harvest mode is initiated when the temperature is satisfied with the shut-off arm in the down position.
2. Once the Harvest mode is initiated, the heater is operated for 30 seconds.
3. After 30 seconds, the ejector blades are operated. (Pin 10 of micom from the hall sensor will read 5V.)
4. Once the ejector blades have reached the park position and the hall sensor is reading 0V, water fill will be initiated.

NOTE : If no movement is detected from the shut-off arm (detect lever), **that** a Harvest mode will be attempted every 2 hours.

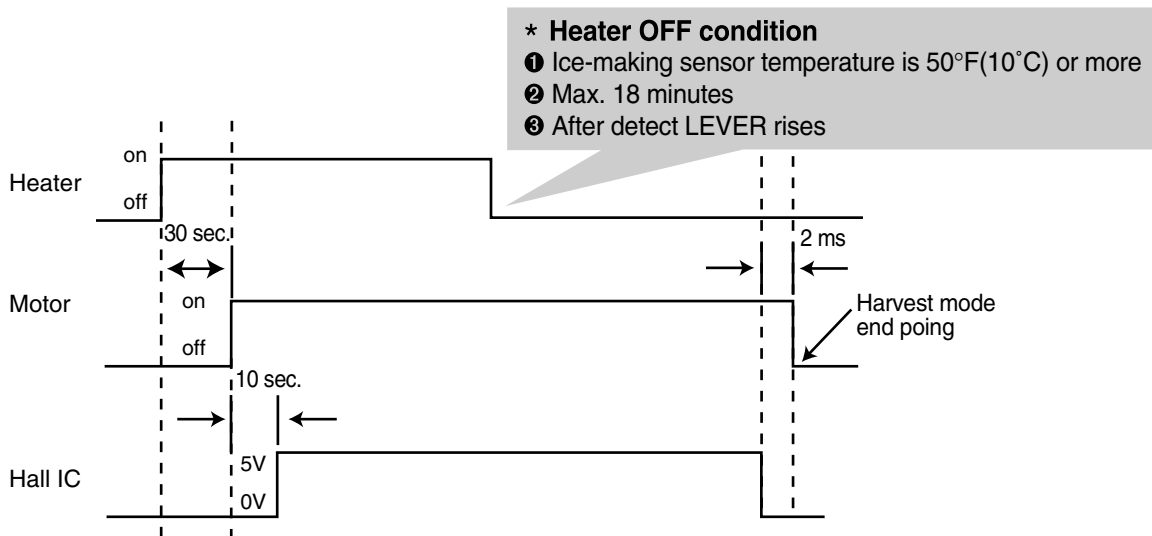





<fig1. Harvest mode process>

7-2-4 Fill / Park Position

1. Once a normal harvest mode has been completed, the water solenoid will be activated.
2. The amount of water is adjusted by pressing the water supply control Switch. This changes the time allowed for fill as illustrated in the chart.

Water supply amount TABLE

STAGE	TIME TO SUPPLY	INDICATIONS	REMARKS
1	6 sec.		The water amount will vary depending on the water control Switch setting, as well as the water pressure of the connected water line.
2	7 sec.		
3	8 sec.		
4	9 sec.		
5	10 sec.		



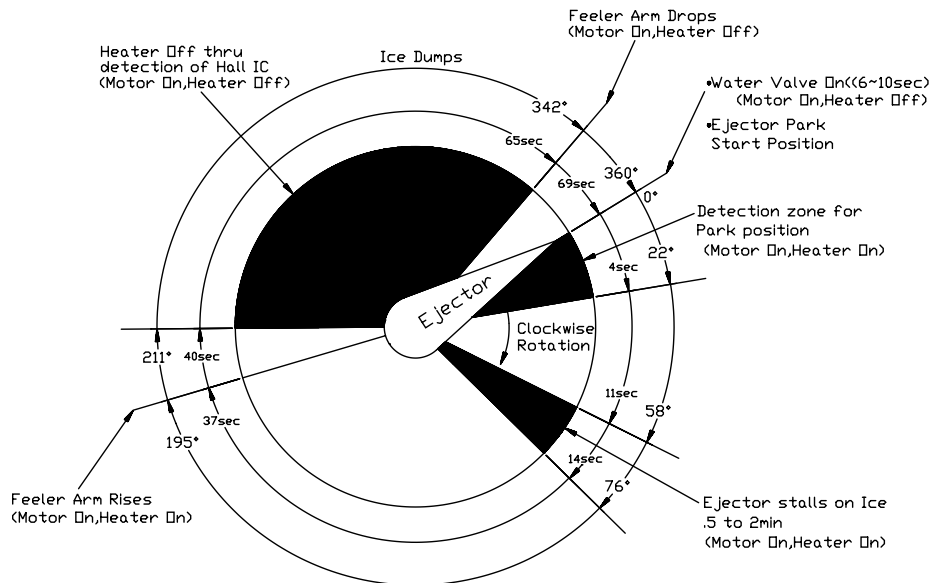

NOTE : Below is an example used by another vendor as an explanation of what is taking place.



7-2-5 Function TEST



1. This is a compulsory operation for TEST, SVC, cleaning, etc. It is operated by pressing the water supply control KEY for 3 seconds.
2. It operates in the Icemaking mode, but not in the Ice-Removing mode or water supply process. (If there is an ERROR, it can only be checked in the TEST mode.)
3. If the water supply control KEY is pressed for 3 seconds in the Ice-Making mode (no matter what condition the Ice-Making tray is in) the Ice-Removing operation starts immediately. Water is not yet frozen, so water is poured instead of ice. If the control doesn't operate normally in the TEST mode, check and repair as needed.
4. After water is supplied, the normal CYCLE is followed: **ice making** → **Harvest** → **Fill** → **Park position**.
5. When Stage 5 is completed in the TEST mode, minimize MICOM in 5 seconds, the time needed to supply water resets to the previous status in the TEST mode.

Diagnosis TABLE

STAGE	ITEMS	INDICATOR	REMARKS
1	HEATER		Five seconds after heater starts, heater will go off if temperature recorded by sensor is 50°F(10°C) or lever is in up position.
2	MOTOR		Five seconds after heater starts, you can confirm that motor is moving.
3	HALL IC (detection of position) I		You can confirm Hall IC detection of position.
4	VALVE		Two seconds after detection of initial position, you can confirm that valve is on.
5	HALL IC (detection of full-filled Ice) II		You can check whether is sensing Full ice condition. (If there is a full-filled error, the fifth LED is not on.)
6	reset	Mark previous status on TEST mode	Five seconds after fifth stage is completed, the Icemaker reset at initial status.

7-3 DEFECT DIAGNOSIS FUNCTION

7-3-1 ERROR CODES shown on Ice Maker water supply control panel

NO	DIVISION	INDICATOR	CONTENTS	REMARKS
1	Normal	Mark time to supply	None	Display switch operates properly
2	Ice-Making Sensor malfunction		Open or short-circuited wire	Make sure that the wire on each sensor is connected.
3	Ice Maker Kit malfunction		When ejector blades don't reach park position over 18 minutes since Harvest Mode starts.	Defects of HALL IC/MOTOR/HEATER/RELAY

ERROR indicators in table can be checked only in TEST mode.

8. DESCRIPTION OF FUNCTION & CIRCUIT OF MICOM

8-1 FUNCTION

8-1-1 Function

- When the appliance is plugged in, it is set to "37 °F" for the Refrigerator and "0 °F" for the Freezer (set to "4" for Refrigerator and "4" for Freezer).
You can adjust the Refrigerator and the Freezer control temperature by pressing the COLDER button or the COLD button.
- When the power is initially applied or restored after a power failure, it is automatically reset to "37 °F" and "0 °F" (set to "4" and "4").

Sears Best Model

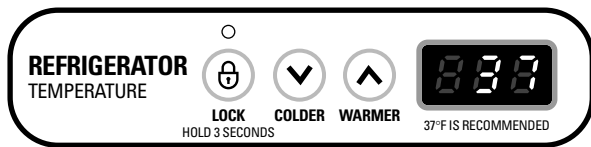

Control range : 32°F ~ 47°F
0°C ~ 8°C

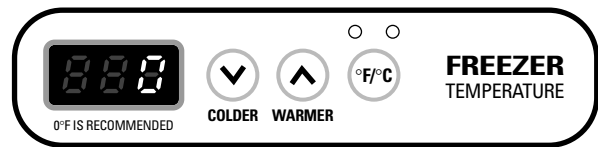

Control range : -6°F ~ 8°F
-21°C ~ -13°C

Sears Better Model

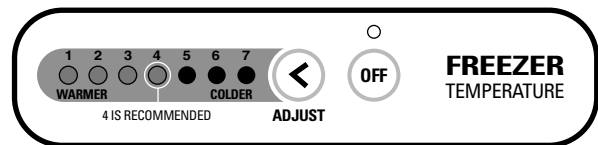
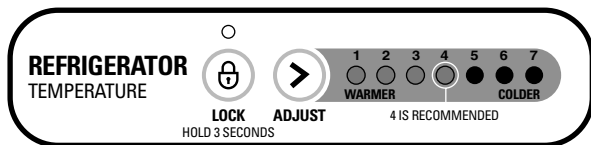

8-1-2 How to Change the Temperature Mode to °F / °C

- The setting temperature mode can be changed to °F / °C by pressing the " °F / °C " button.
- The initial setting is on °F. When the mode is changed the LED lights come on.



8-1-3 Key Lock

- The key pads can be locked by pressing and holding the KEY LOCK button for 3 seconds.
- The lock light will be displayed and the key pads will be inoperable.
- Pressing and holding the KEY LOCK button for 3 seconds will reactivate the key pads.

8-1-4 OFF Function

- To turn off the Best model, press and hold the °F/°C button for 3 seconds. To turn off the Better model, press and hold the OFF key for 3 seconds.
- In the Off mode, the Best model will display OFF in the control panel. The OFF light will be displayed on the Better model.
- To cancel the OFF function, press the same keys and hold for 3 seconds.



8-1-5 Alarm for Open Door

1. This feature sounds a buzzer when the freezer or refrigerator door is not closed within 1 minute after it is opened.
2. One minute after the door is opened, the buzzer sounds three times each for 0.5 seconds. These tones repeat every 30 seconds.
3. The alarm is cancelled when the freezer or the refrigerator is closed while the buzzer sounds.

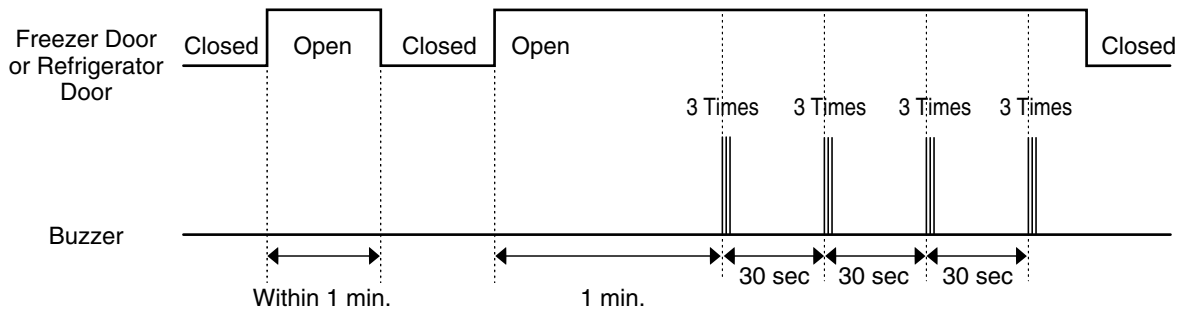

8-1-6 Buzzer Sound

When the button on the front Display is pushed, a "Ding~" sound is produced.

8-1-7 Defrost Cycle

1. A defrost cycle will be initiated after 4 hours of accumulated compressor run time after the initial power up or a power failure.
2. After the initial defrost, the defrost cycle is initiated after 7  of accumulated compressor run time.
3. The defrost cycle will be terminated once the defrost sensor reaches 50°F(10°C).

8-1-8 Electrical Parts Operates in Orders

Electrical parts such as COMP, defrost heater, freezer FAN, etc. operate in the following order to prevent noise and parts damage. Several parts are started at the same time at initial power on and are turned off together when TEST is completed.

OPERATING		 ORDERS				
Initial power on	Temperature of Defrost Sensor is 113°F(45°C) or more (when unit is newly purchased or when moved)	POWER ON	in 1/2 second →	COMP ON	in 1/2 second →	Freezer FAN ON
	Temperature of defrost sensor is lower than 113°F(45°C) (when power cuts, SERVICE)	POWER ON	in 1/2 second →	Defrost heater ON	in 10 second →	Defrost heater OFF
		in 1/2 second →	COMP ON	in 1/2 second →	Freezer FAN ON	
	Reset to normal operation from TEST MODE	Total load OFF	in 7 minute →	COMP ON	in 1/2 second →	Freezer FAN ON

8-1-9 Defect Diagnosis Function

1. Defect diagnosis functions are easy SVC when defects occur which can affect product performance.
2. When a defect occurs, the buttons will not operate, but the tones, such as "ding", will sound.
3. When the defect CODE removes the sign, it returns to normal operation (RESET).
4. The defect CODE shows on the refrigerator DISPLAY as temperature LED, and the other LED turns off.

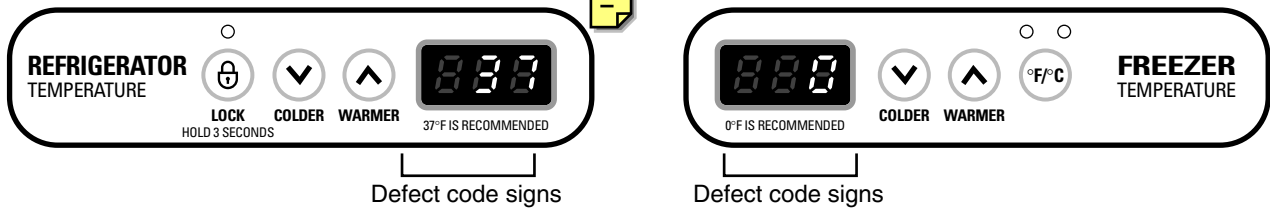

-Show ERROR CODE on Refrigerator Temperature Panel and Freezer Temperature panel.

NO	ITEM	ERROR CODE		CONTENTS	REMARKS
		REF. TEMP. PANEL	FRZ. TEMP. PANEL		
1	Freezer sensor malfunctions	Er	F5	Open or short-circuited wire	*Inspect connecting wires on each sensor
2	Refrigerator sensor malfunctions	Er	r5	Open or short-circuited wire	
3	Defrost sensor malfunctions	Er	d5	Open or short-circuited wire	
4	Room Temperature sensor malfunctions	On LED CHECK mode ERROR CODE sign		Open or short-circuited wire	
		Er	rT		
5	Defrosting malfunctions	Er	dH	2 hours after defrosting starts, the sensor is not above 50°F(10°C)	Temperature FUSE cuts off, HEATER cuts off, DRAIN is clogged, HEATER starts, RELAY malfunctions

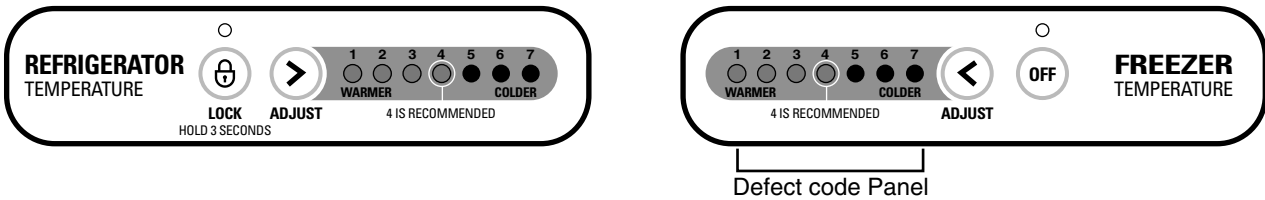

ERROR CODE on Freezer Temperature panel

☉ :ON ● :OFF

NO	ITEM	DEFECT SIGNS							CONTENTS	REMARKS
		F1	F2	F3	F4	F5	F6	F7		
1	Freezer sensor malfunctions	●	☉	☉	☉	☉	☉	☉	Open or short-circuited wire	*Inspect connecting wires on each sensor
2	Refrigerator sensor malfunctions	☉	●	☉	☉	☉	☉	☉	Open or short-circuited wire	
3	Defrost sensor malfunctions	☉	☉	●	☉	☉	☉	☉	Open or short-circuited wire	
4	Room Temperature sensor malfunctions	On LED CHECK mode							Open or short-circuited wire	
		●	☉	●	☉	☉	☉	☉		
5	Defrosting malfunctions	●	●	●	●	☉	☉	☉	2 hours after defrosting starts, the sensor is not above 50°F(10°C)	Temperature FUSE cuts off, HEATER cuts off, DRAIN is clogged, HEATER starts, RELAY malfunctions

8-1-10 TEST Mode

1. The Test mode allows checking the PCB and the function of the product as well as  ng out the Defective part in case of an error.
2. The test button is on the main PCB of the refrigerator (Test S/W). The test mode will be cleared in 2 hours regardless of the type of test mode.
3. While in the test mode, the function control button will not operate, though the recognition tone (beep~) sounds.
4. After exiting the test mode, be sure to reset by unplugging and then plugging in the appliance.
5. If an error (such as a sensor failure) is detected while in the test mode, the test mode is cleared and the error code is displayed.
6. While an error code is displayed, the test mode will not be activated even if the test button is pushed.

MODE	MANIPULATION	CONTENTS	REMARKS
TEST1	Push the test button once.	1. Continuous operation of the COMP 2. Continuous operation of the freezer fan 3. STEPPING DAMPER OPEN 4. Defrosting Heater OFF 5. Every DISPLAY LED ON	
TEST2	Push the test button once while in TEST MODE 1.	1. COMP OFF 2. Freezer FAN OFF 3. STEPPING DAMPER CLOSE 4. Defrosting heater ON 5. DISPLAY LED shows 222	Reset if the temperature of the Defrosting sensor is 50°F(10°C) or more.
Reset	Push the test button once while in TEST MODE 2.	Reset to the default setting	The compressor will Start after a 7-minute delay.

8-2 PCB FUNCTION

8-2-1 Power Circuit

1. Power is supplied to the control board at pins 1 and 3 of connector #1.

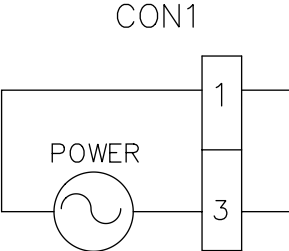

8-2-2 Load / Buzzer Drive & Open Door Detection Circuit

1. Load Drive Condition Check

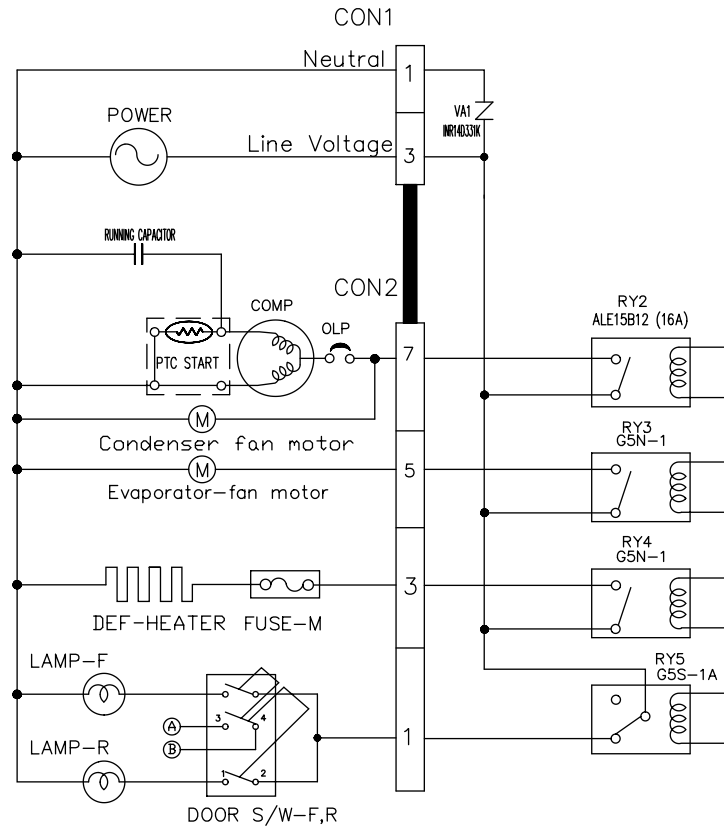

To measure outputs of the control board, check voltages between the pins for the following components:

Circuit	Pin Number	Pin Number	Output Voltage
Compressor	Con2 pin7	Con1 pin1	115 VAC
Condenser fan	Con2 pin7	Con1 pin1	115 VAC
Evaporator fan	Con2 pin5	Con1 pin1	115 VAC
Defrost heater	Con2 pin3	Con1 pin1	115 VAC
F,R-lamp	Con2 pin1	Con1 pin1	115 VAC

NOTE: When the door of the freezer/refrigerator is left open for 7 minutes or longer, the lamp of the freezer/refrigerator turns off automatically.

2. Open Door Circuit (Door Monitor Circuit)

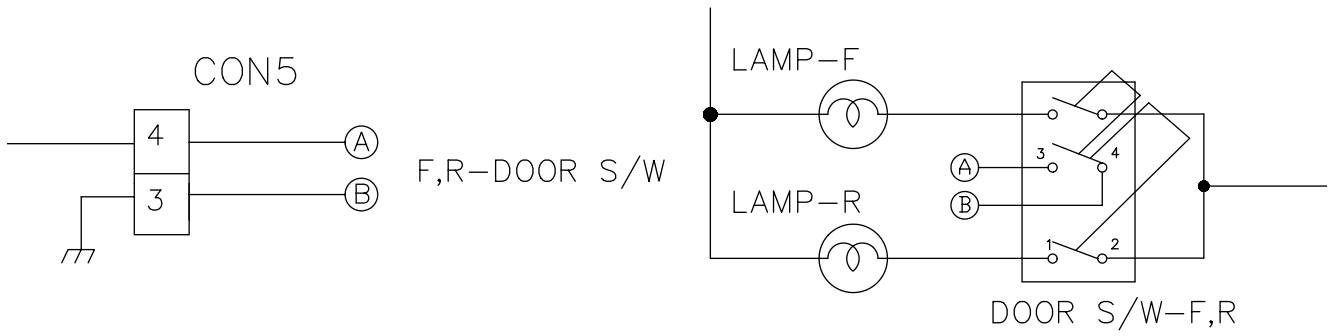

Freezer or Refrigerator	Measurement between pins 4 and 3 at Con 5
Both Closed	0 volts
One door open	5 volts

8-2-3 Temperature Sensor Circuit

Voltage supplied to each sensor will range between 0.5 volts $-22^{\circ}\text{F}(-30^{\circ}\text{C})$ and 4.5 volts $122^{\circ}\text{F}(50^{\circ}\text{C})$ depending upon the temperature in the compartments. A measurement of 0 volts indicates a short in the sensor circuit. A measurement of 5 volts indicates an open in the sensor circuit.

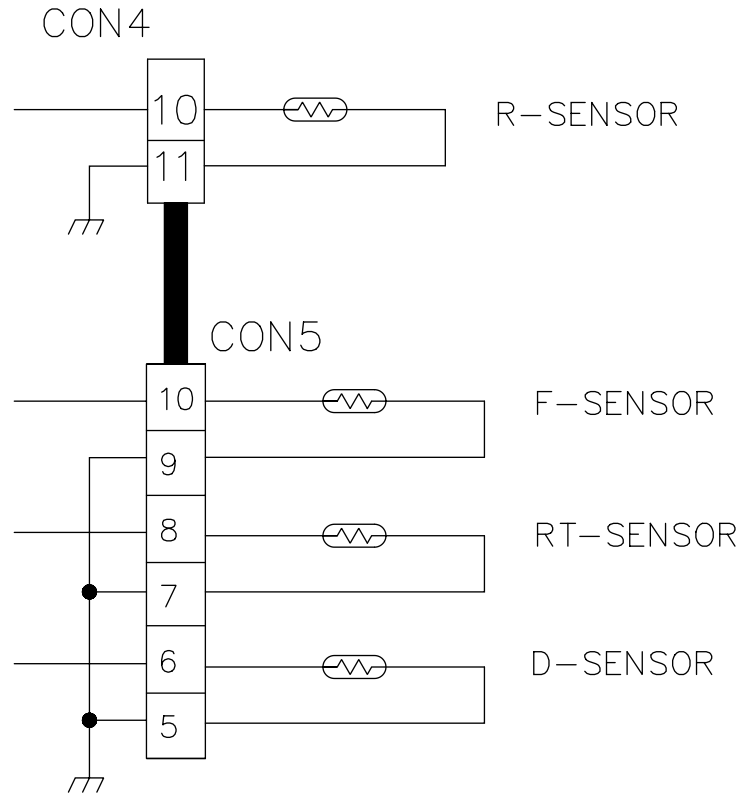

8-2-4 Motor Damper **Circuit**

A reversible DC motor is used to open and close the damper.
To open the damper, push test button once.
To close the damper, push test button twice.

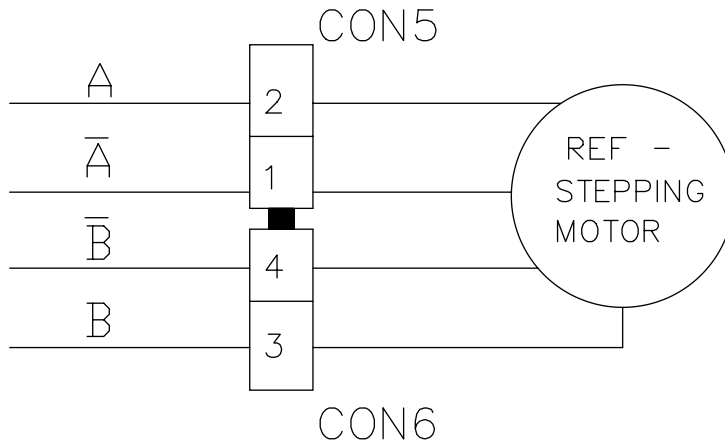

8-2-5 Damper Heater

* The damper heater is attached to the baffle and always will be on if the unit is powered on. The damper heater uses 12VDC.

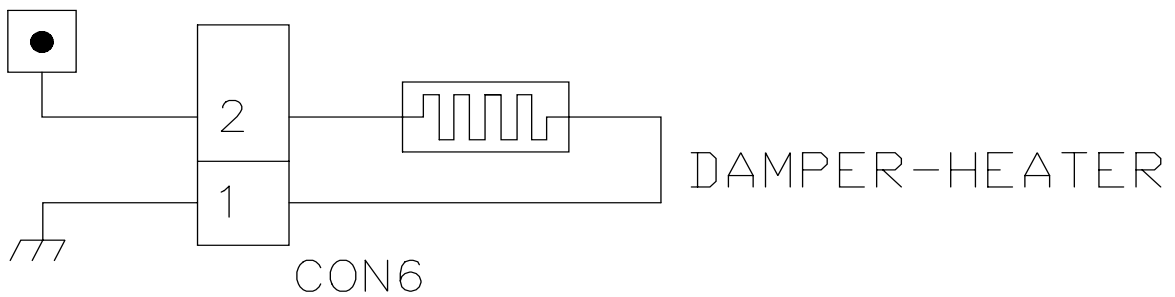

8-2-6 Key Button Input & Display Light On Circuit

LED CHECK MODE: When the COLDER(ADJUST) button in the refrigerator temperature control and the COLDER(ADJUST) button in the freezer temperature control are pushed and held for 1 second or longer, every LED on the display turns on at the same time. When the buttons are released, the previous mode is restored.

Best Model

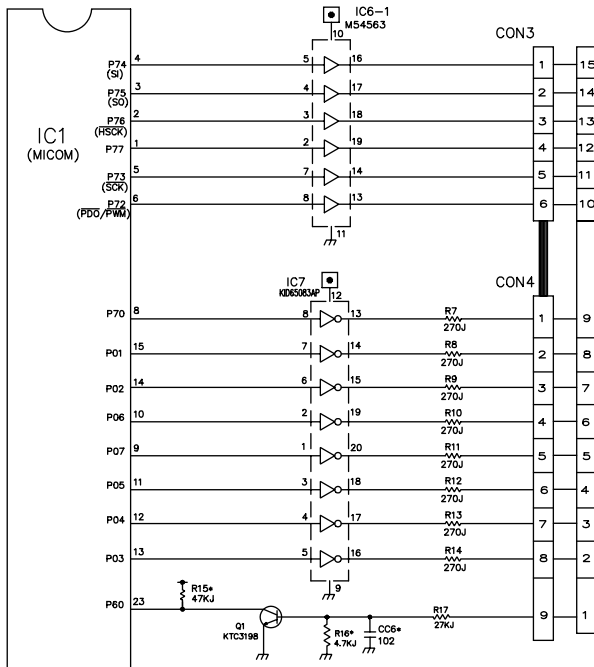

Better Model

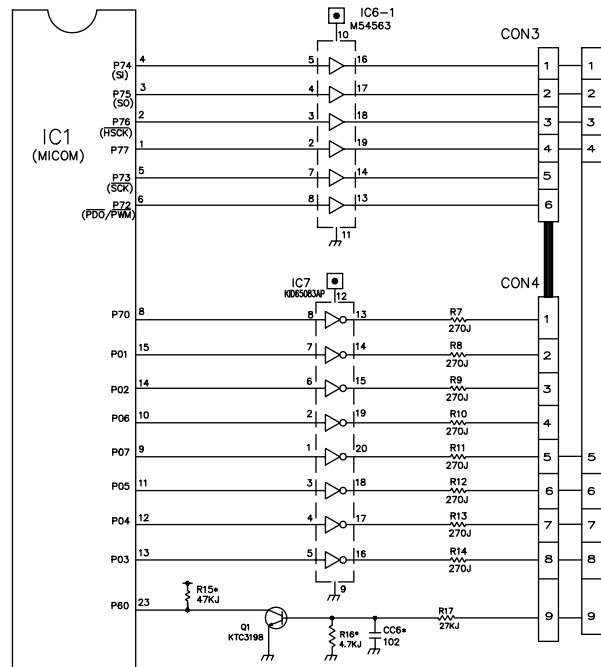

8-3 RESISTANCE SPECIFICATION OF SENSOR

TEMPERATURE	RESISTANCE OF FREEZER SENSOR	RESISTANCE OF REFRIGERATOR & DEFROST SENSOR
- 20 °C (-4 °F)	22.3 KΩ	77 KΩ
- 15 °C (5 °F)	16.9 KΩ	60 KΩ
- 10 °C (14 °F)	13.0 KΩ	47.3 KΩ
- 5 °C (23 °F)	10.1 KΩ	38.4 KΩ
0 °C (32 °F)	7.8 KΩ	30 KΩ
+ 5 °C (41 °F)	6.2 KΩ	24.1 KΩ
+ 10 °C (50 °F)	4.9 KΩ	19.5 KΩ
+ 15 °C (59 °F)	3.9 KΩ	15.9 KΩ
+ 20 °C (68 °F)	3.1 KΩ	13 KΩ
+ 25 °C (77 °F)	2.5 KΩ	11 KΩ
+ 30 °C (86 °F)	2.0 KΩ	8.9 KΩ
+ 40 °C (104 °F)	1.4 KΩ	6.2 KΩ
+ 50 °C (122 °F)	0.8 KΩ	4.3 KΩ

- The resistance of the SENSOR has a $\pm 5\%$ common difference.
- Measure the resistance of the SENSOR after leaving it for over 3 minutes in the measuring temperature. This delay is necessary due to sensor response speed.

8-4 TROUBLESHOOTING

COMPLAINT	SYMPTOM	POSSIBLE CAUSES	SOLUTION
Electronic Display not operating correctly	1. No Display at all	<ol style="list-style-type: none"> 1. Supply voltage not within specifications 2. Open in wiring harness from PWB board 3. Open in door monitor switch circuit 	<ol style="list-style-type: none"> 1. Check supply voltage to refrigerator 2. Check wiring and connectors to PWB board 3. Check door monitor circuit
	2. Partial or abnormal display	<ol style="list-style-type: none"> 1. Supply voltage not within specifications 2. Open in wiring harness from PWB board 	<ol style="list-style-type: none"> 1. Check supply voltage to refrigerator 2. Check wiring and connectors to and from PWB board
Not Cooling	1. Display on but compressor not operating	<ol style="list-style-type: none"> 1. Compressor not operating 2. Open in compressor circuit 	<ol style="list-style-type: none"> 1. Check for compressor operation by using the test key on main circuit board 2. Check for open on OLP, PTC, compressor, wiring, etc.
Not cold enough	2. Display on compressor is operating	<ol style="list-style-type: none"> 1. Condenser fan motor not operating 2. Condenser coils blocked 3. Evaporator fan motor not operating 4. Damper not opening or internal air flow blocked 5. Sensor not operating properly 6. Door not sealing 7. Evaporator Frosted up 8. Sealed System related problem 	<ol style="list-style-type: none"> 1. Check condenser fan motor and wiring circuit 2. Check air flow across condenser 3. Check evaporator fan motor and wiring circuit 4. Check damper motor circuit 5. Check refrigerator and freezer sensors 6. Check for proper door esal  7. Check defrost circuit components
		1. Freezer has too much frost	<ol style="list-style-type: none"> 1. Open in defrost circuit 2. Defrost sensor not operating correctly 3. Defrost drain clogged
Not defrosting			

8-5 MAIN PWB ASSEMBLY AND PARTS LIST

8-5-1 Main PWB Assembly

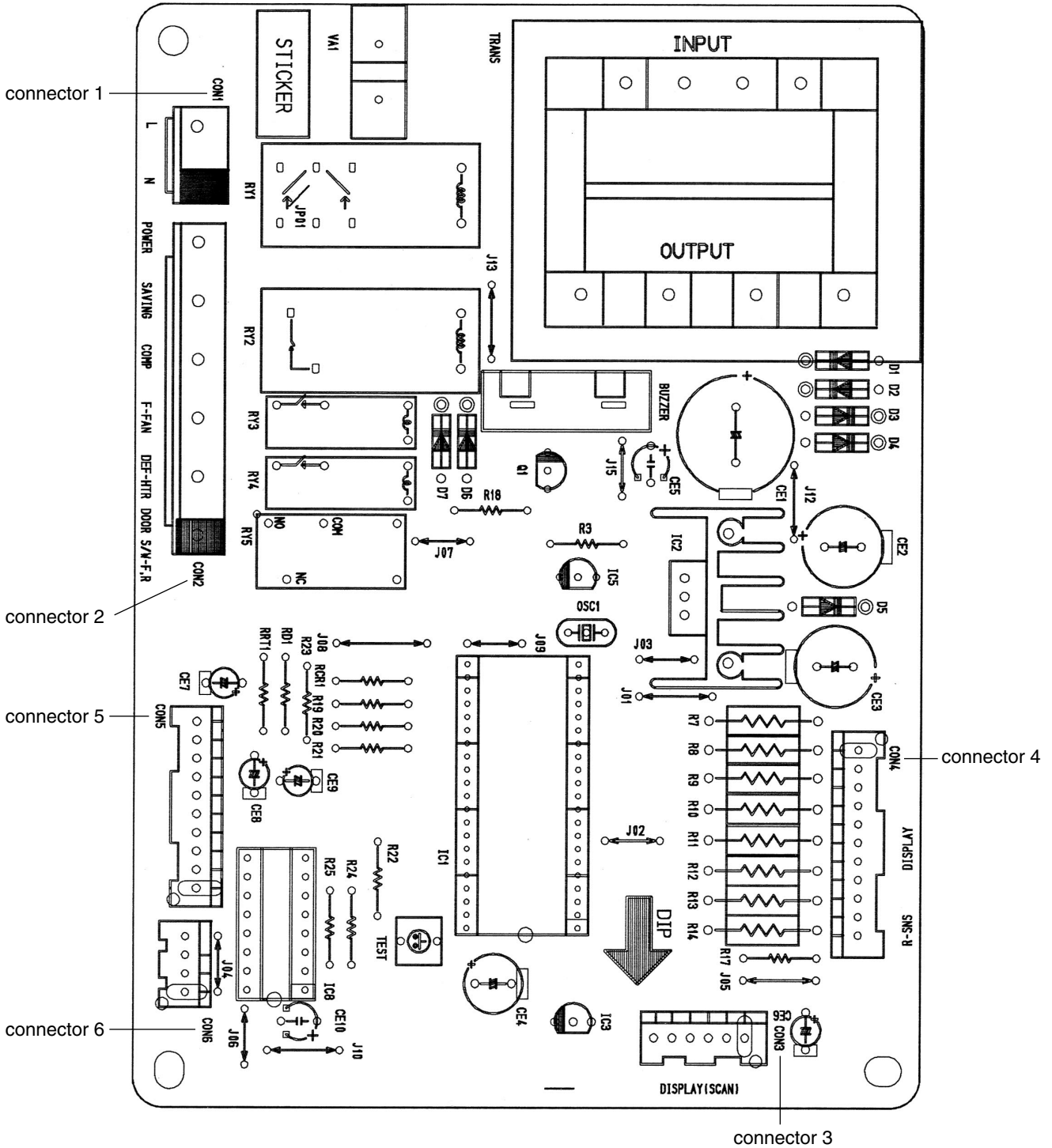

FREEZER PARTS

CAUTION: Use the part number to order part, not the position number.

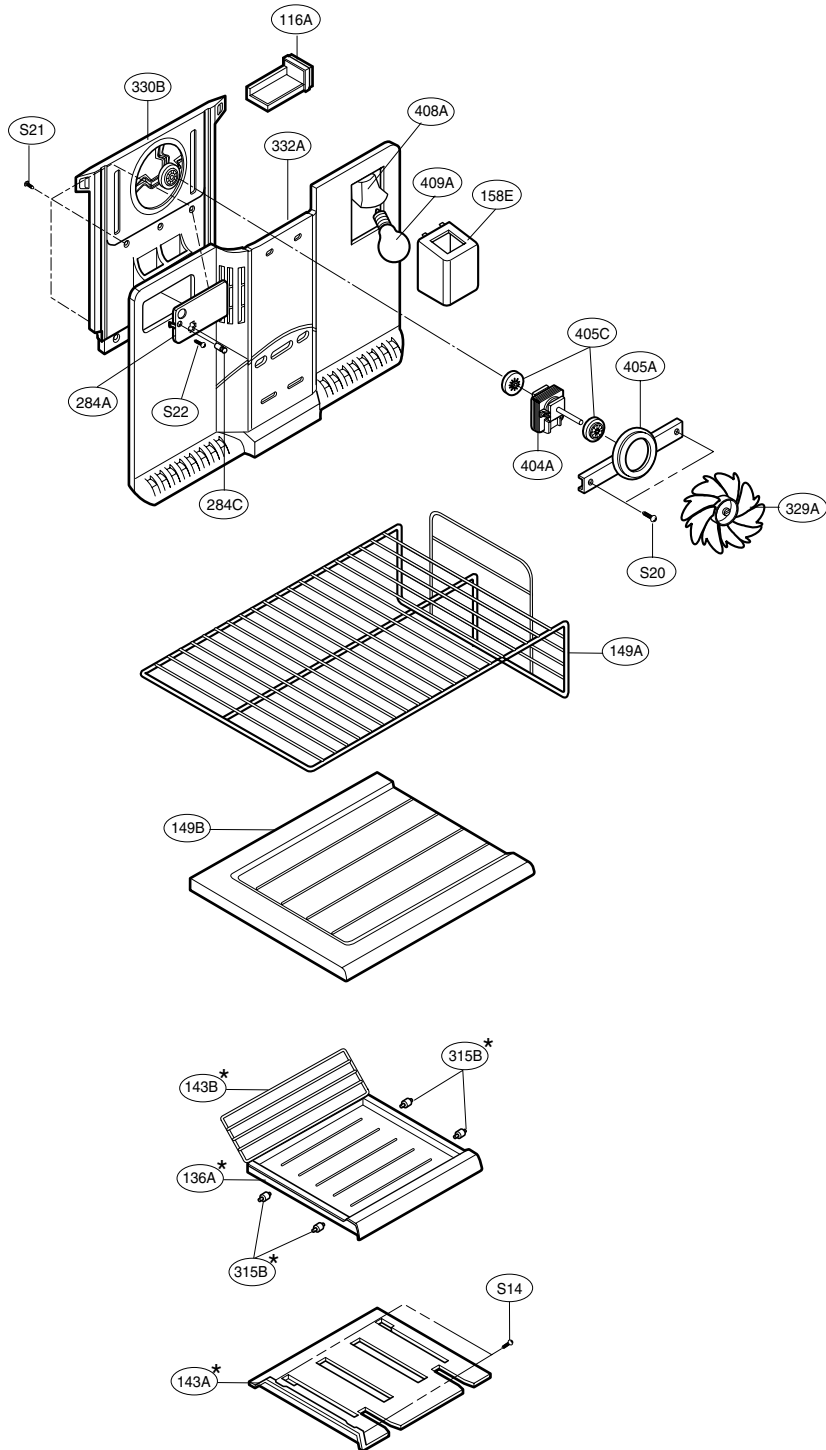

REFRIGERATOR PARTS

CAUTION: Use the part number to order part, not the position number.

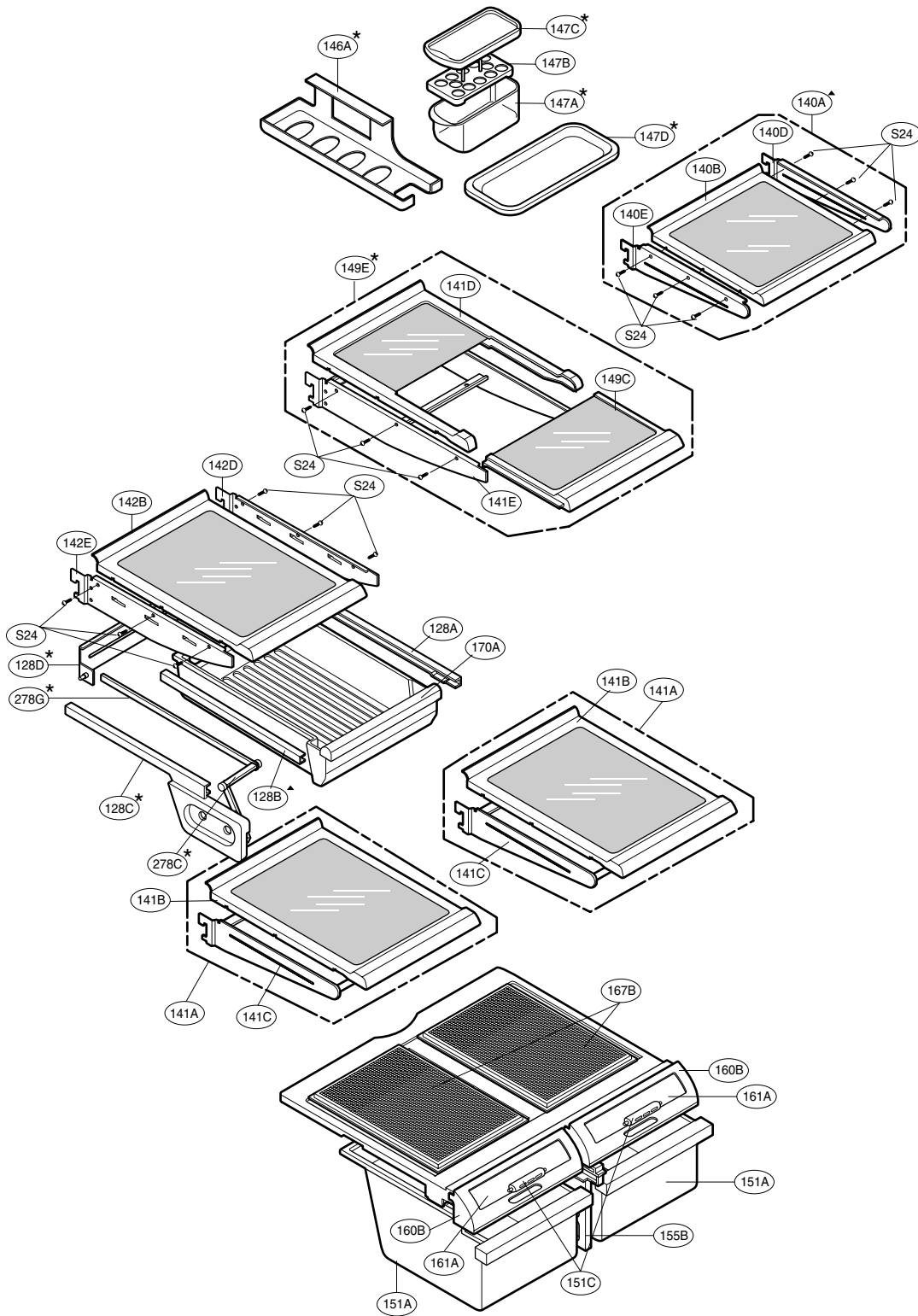

▲, * : On some models

DOOR PARTS

CAUTION: Use the part number to order part, not the position number.

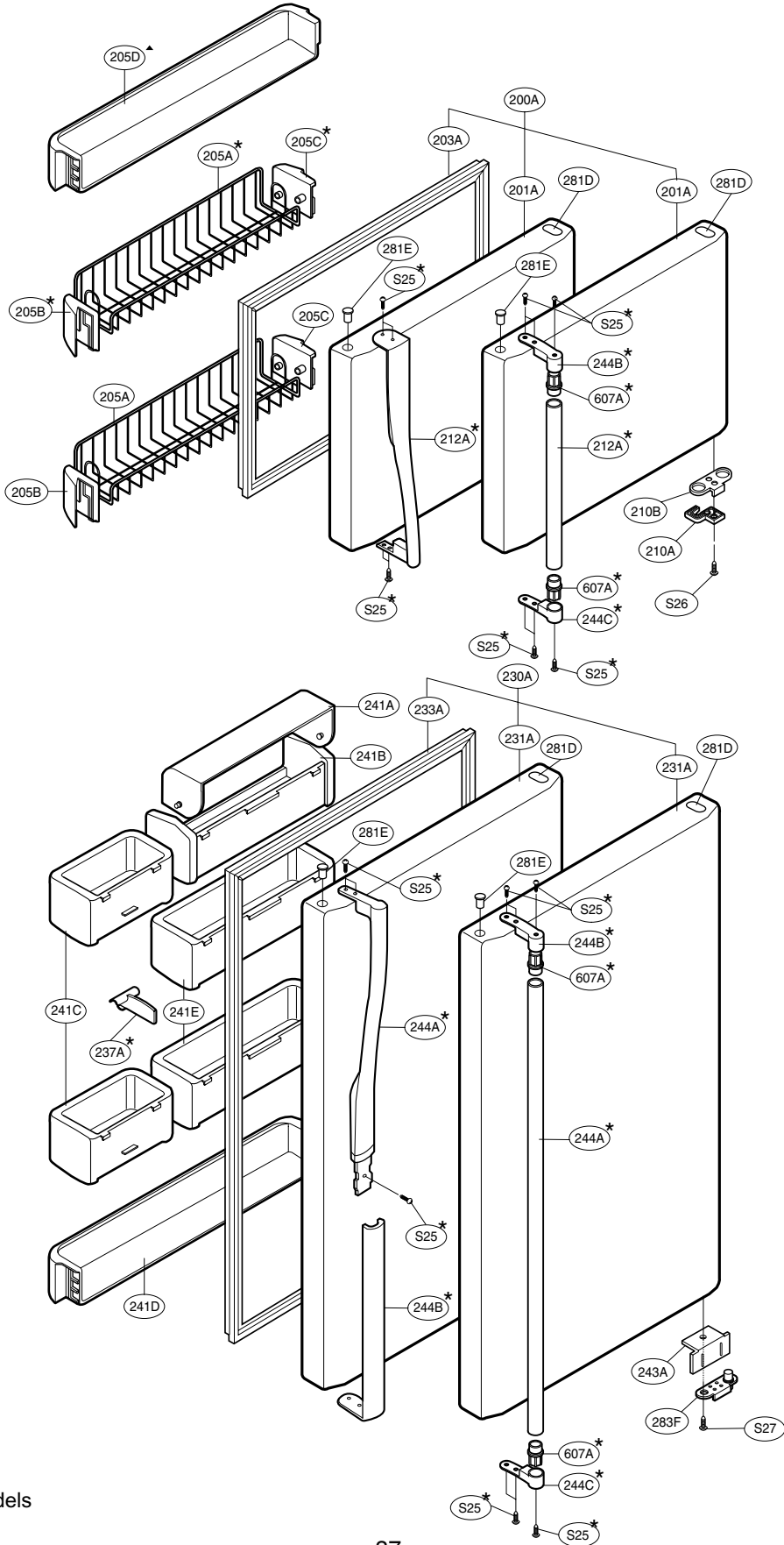

▲, * : On some models

ICE MAKER PARTS

CAUTION: Use the part number to order part, not the position number.

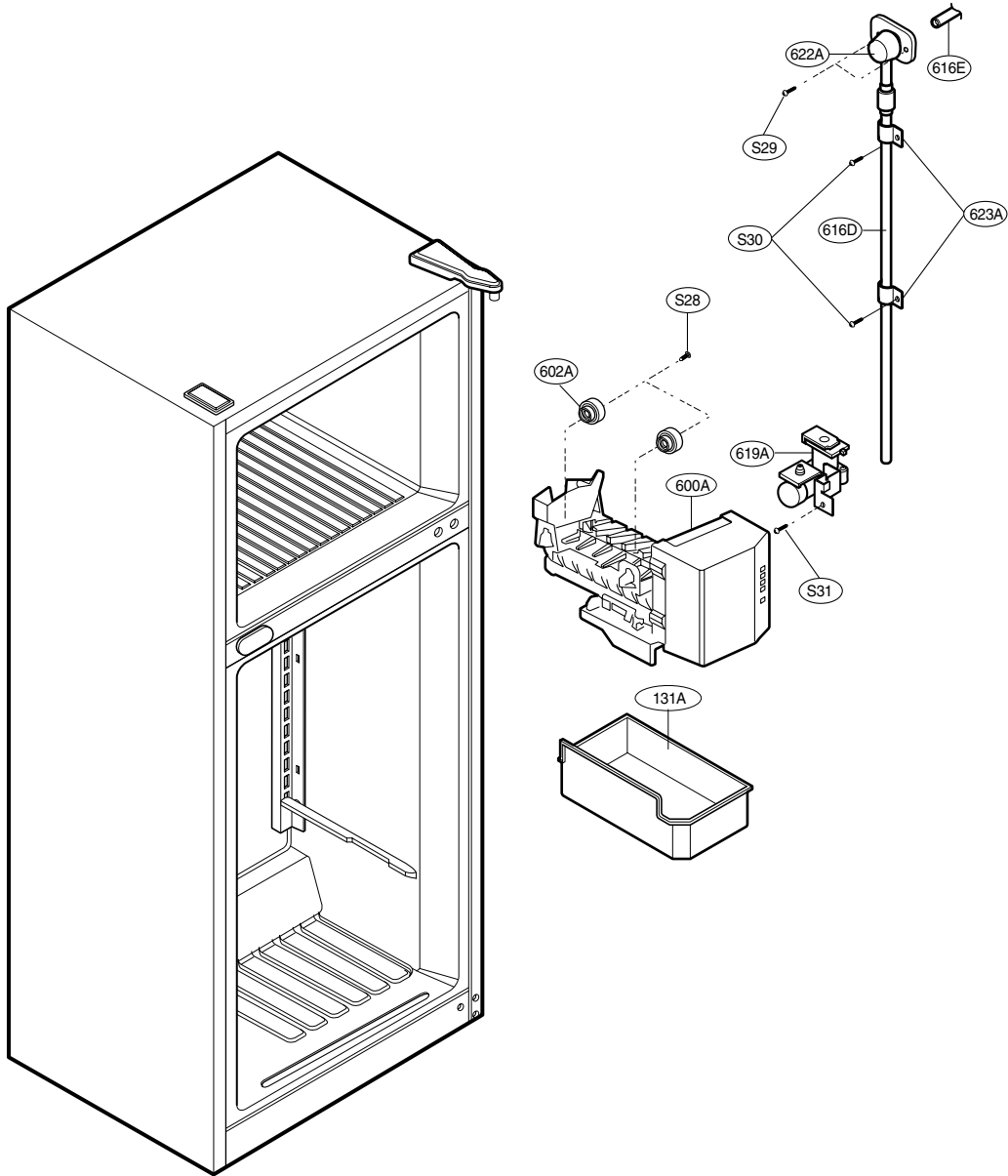

ICE MAKER PARTS (LOC#600A)

NON SERVICEABLE PARTS

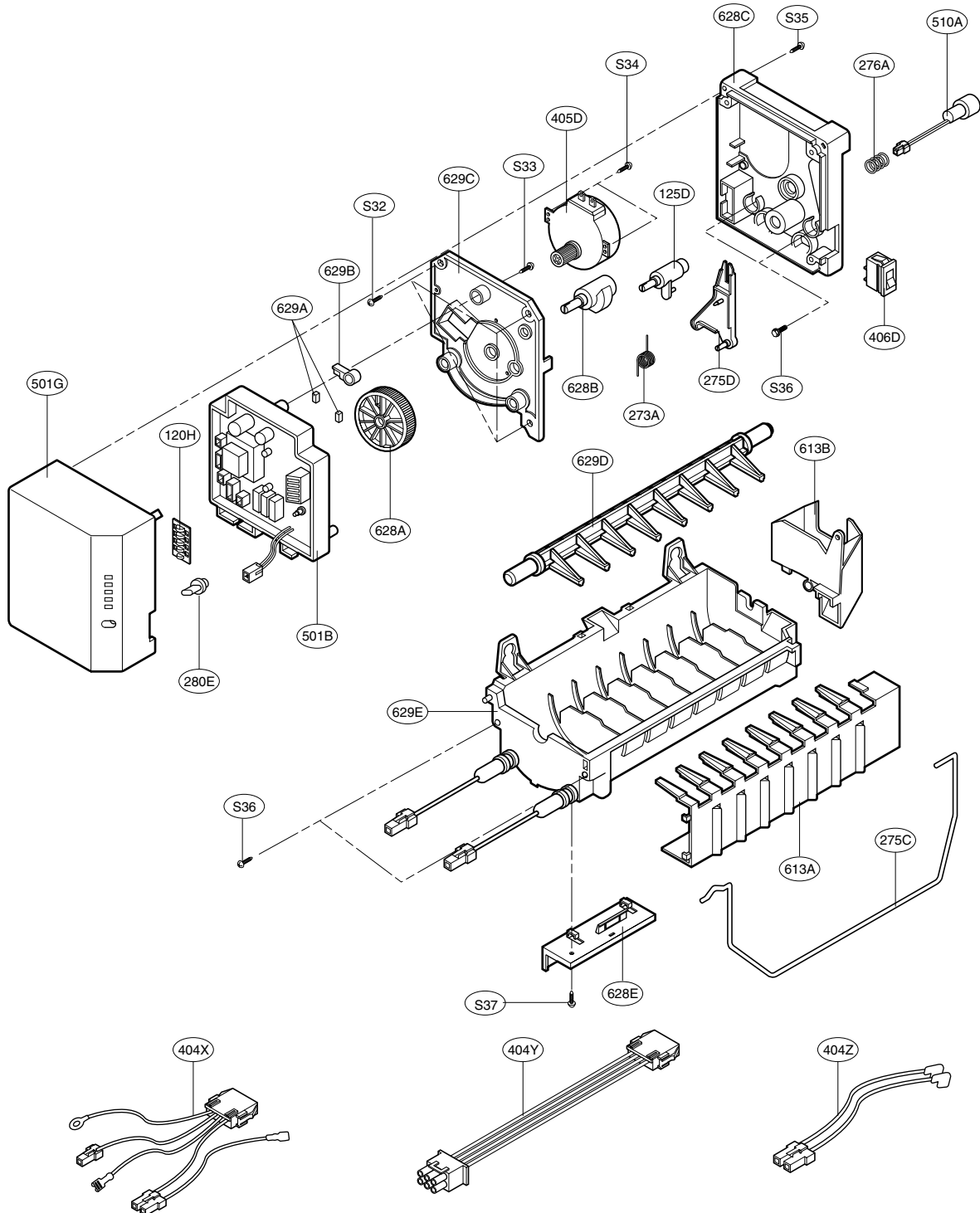



P/No. 3828JL8008A

 ARZO, 2003 Printed in México