



LG

REFRIGERATOR

SERVICE MANUAL

CAUTION
BEFORE SERVICING THE UNIT,
READ THE SAFETY PRECAUTIONS IN THIS MANUAL.

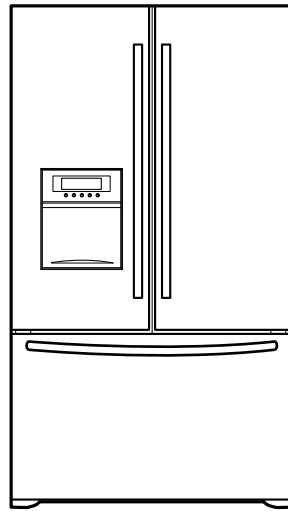
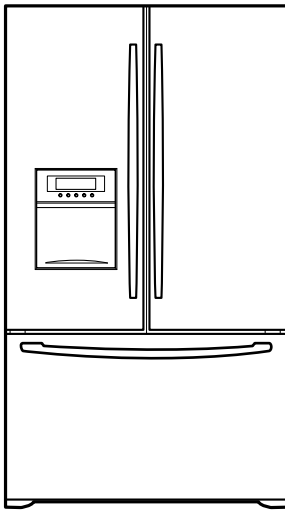

MODEL: LRFD25850SB

COLOR:WESTERN BLACK

CONTENTS

SAFETY PRECAUTIONS	2
1. SPECIFICATIONS	3
2. PARTS IDENTIFICATION	4
3. DISASSEMBLY	5-8
REMOVING AND REPLACING REFRIGERATOR DOORS	5
DOOR	6-7
TO REMOVE THE DISPENSER	7
DOOR ALIGNMENT	7
FAN AND FAN MOTOR	8
DEFROST CONTROL ASSEMBLY	8
LAMP	8
CONTROL BOX-REFRIGERATOR	8
MULTI DUCT	8
4. ADJUSTMENT	9-10
COMPRESSOR	9
PTC-STARTER	9
OLP (OVERLOAD PROTECTOR).....	10
TO REMOVE THE COVER PTC	10
5. CIRCUIT DIAGRAM	11
6. TROUBLESHOOTING	12-17
COMPRESSOR AND ELECTRIC COMPONENTS	12
PTC AND OLP	13
OTHER ELECTRICAL COMPONENTS	14
SERVICE DIAGNOSIS CHART	15
REFRIGERATION CYCLE	16-17
7. OPERATION PRINCIPLE & REPAIR METHOD OF ICEMAKER	18-21
8. DESCRIPTION OF FUNCTION & CIRCUIT OF MICOM	22-33
9. EXPLODED VIEW & REPLACEMENT PARTS LIST	34-

SAFETY PRECAUTIONS

Please read the following instructions before servicing your refrigerator.

1. Check the refrigerator for current leakage.
2. To prevent electric shock, unplug before servicing.
3. Always check line voltage and amperage.
4. Use standard electrical components.
5. Don't touch metal products in the freezer with wet hands. This may cause frostbite.
6. Prevent water from spilling onto electric elements or the machine parts.
7. Close the top door before opening the bottom door. Otherwise, you might hit your head when you stand up.
8. When tilting the refrigerator, remove any materials on the refrigerator, especially the thin plates (ex. glass shelf or books.)
9. When servicing the evaporator, wear cotton gloves. This is to prevent injuries from the sharp evaporator fins.
10. Service on the refrigerator should be performed by a qualified technician. Sealed system repair must be performed by a CFC certified technician.

1. SPECIFICATIONS

21 cu. ft. / 25 cu. ft.

ITEMS	SPECIFICATIONS	ITEMS	SPECIFICATIONS	
DOOR DESIGN	Side Rounded	VEGETABLE TRAY	Opaque Drawer Type	
DIMENSIONS (inches)	35 3/4 x 30 x 69 3/4 (WxDxH) 21cu.ft	COMPRESSOR	PTC Starting Type	
	35 3/4 x 34 1/4 x 69 3/4 (WxDxH) 25cu.ft	EVAPORATOR	Fin Tube Type	
NET WEIGHT (pounds)	298 (21cu.ft)	CONDENSER	Wire Condenser	
	320 (25cu.ft)	REFRIGERANT	R-134a (115 g)	
COOLING SYSTEM	Fan Cooling	LUBRICATING OIL	ISO10 (280 ml)	
TEMPERATURE CONTROL	Micom Control	DEFROSTING DEVICE	SHEATH HEATER	
DEFROSTING SYSTEM	Full Automatic	LAMP	REFRIGERATOR	60 W (2EA)
	Heater Defrost		FREEZER	60 W (1EA)
DOOR FINISH	Embossed Metal, VCM, Stainless			
HANDLE TYPE	Bar			
INNER CASE	ABS Resin			
INSULATION	Polyurethane Foam			

2. PARTS IDENTIFICATION

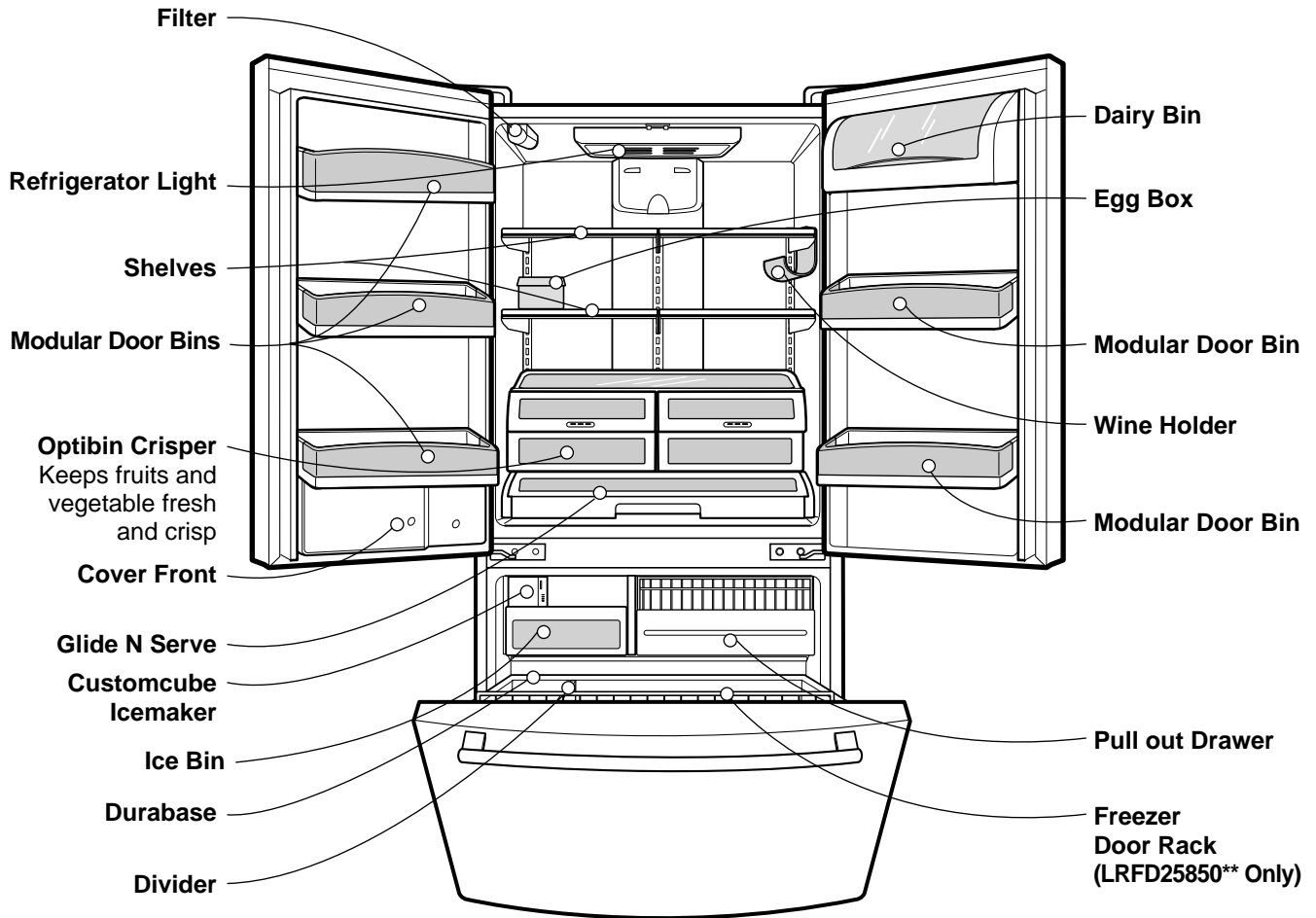

3. DISASSEMBLY

3-1 REMOVING AND REPLACING REFRIGERATOR DOORS

● Removing Refrigerator Door

▲ CAUTION: Before you begin, unplug the refrigerator. Remove food and bins from doors.

▶ Left Door

1. Disconnect water supply tube by pushing back on the disconnect ring (4).
2. Open door. Loosen top hinge cover screw (1).
- Use flat tip screwdriver to pry back hooks on front underside of cover (3). Lift up cover.
3. Disconnect door switch wire harness (2). Remove cover.
4. Attach the tube on the door with door.
5. Pull out the tube.
6. Disconnect the three wire harnesses (5). Remove the grounding screw (6).
7. Rotate hinge lever (7) counterclockwise and remove. Lift top hinge (8) free of hinge lever latch (9).

▲ CAUTION: When lifting hinge free of latch, be careful that door does not fall forward.

8. Lift door up from middle hinge pin (10) and remove door.
9. Place door, inside facing up, down onto a non-scratching surface.

▶ Right Door

1. Open door. Loosen top hinge cover screw (1). Lift up cover (3).
2. Disconnect door switch wire harness (2). Remove cover.
3. Disconnect wire harness (5). Remove the grounding screw (6).
4. Rotate hinge lever (7) clockwise and remove. Lift top hinge (8) free of hinge lever latch (9).

▲ CAUTION: When lifting hinge free of latch, be careful that door does not fall forward.

5. Lift door up from middle hinge pin (10) and remove door.
6. Place door, inside facing up, down onto a non-scratching surface.

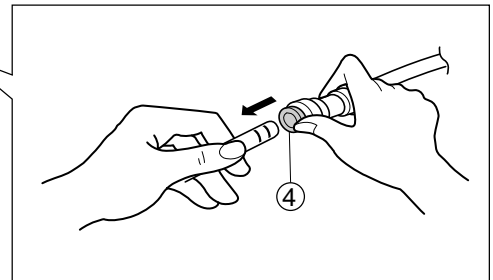
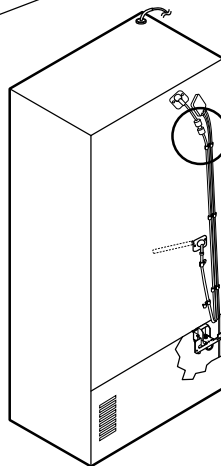
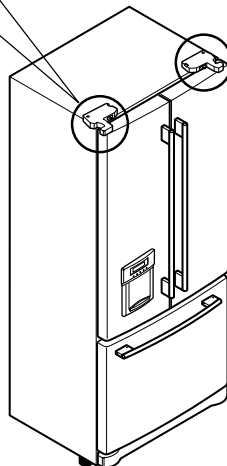
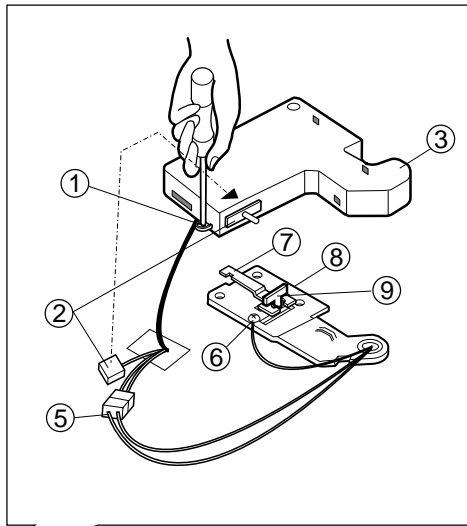
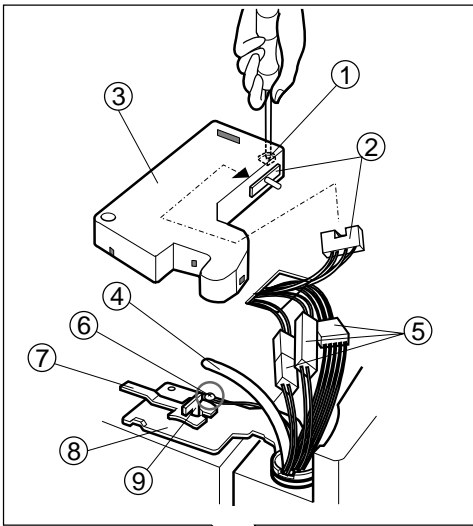

3-2 DOOR

● Door Gasket Removal

1. Remove door frame cover

Starting at top of cover and working down, snap cover out and away from door.

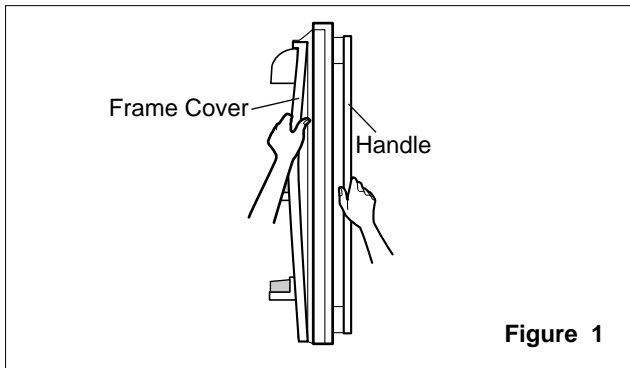

2. Remove gasket bracket clips

There are two clips on each door. Start bracket removal near one of the middle clips.

- 1) Pull gasket back to expose gasket bracket clip and door frame.
- 2) Insert a flat tip screwdriver into seam between gasket bracket and door frame and pry back until clips snaps out.
- 3) Continue prying back along seam until all clips snap out.

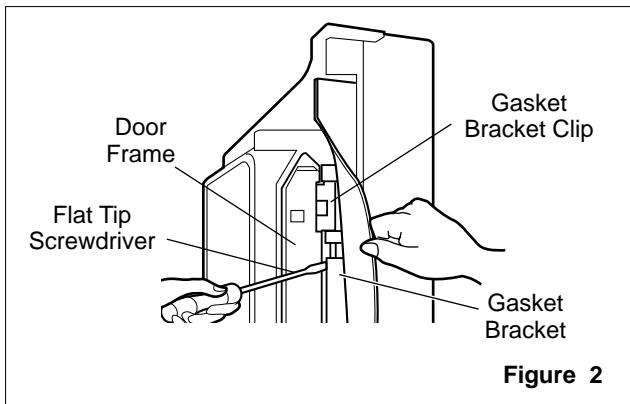

3. Remove gasket

Pull gasket free from gasket channel on the three remaining sides of door.

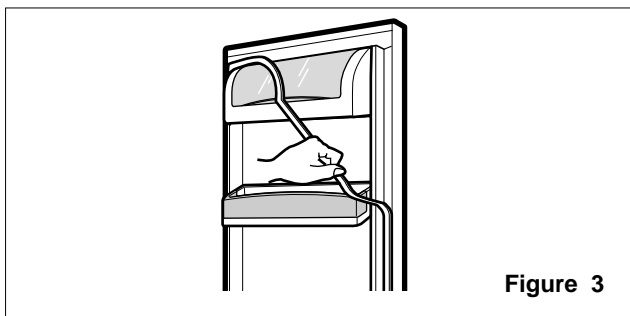

● Door Gasket Replacement

1. Insert gasket bracket clips

- 1) Insert gasket bracket edge beneath door frame edge.
- 2) Turn upper gasket bracket spring so that the spring ends are in the door channel.
- 3) Push in clip until you hear it snap securely into place.

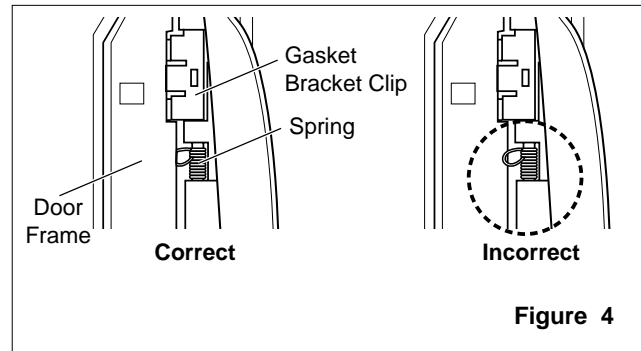

- 4) Push in remaining two clips until you hear each snap securely into place.

Note: Make sure that no part of gasket bracket edge protrudes from beneath door frame edge.

2. Insert gasket into channel

- 1) Snap gasket assembly into the door bracket.

<Inserting the Gasket Assembly into the Bracket Door>

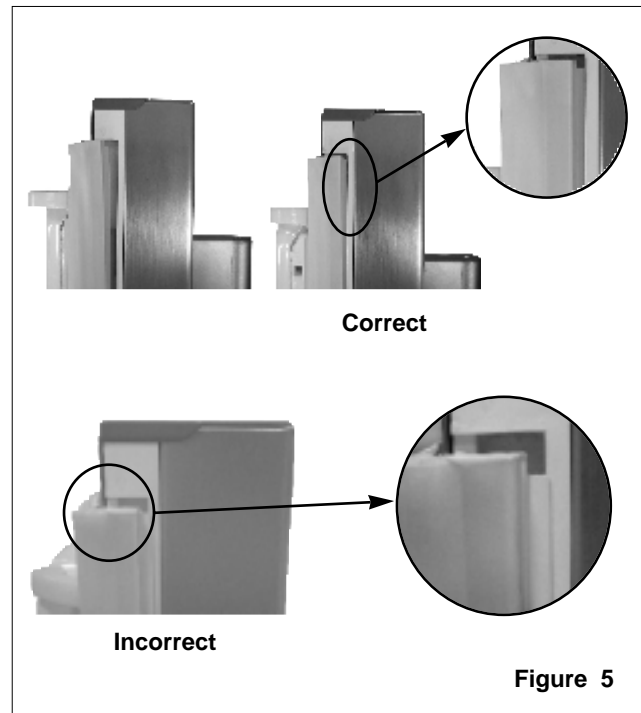

- 2) Press gasket into channels on the three remaining sides of door.

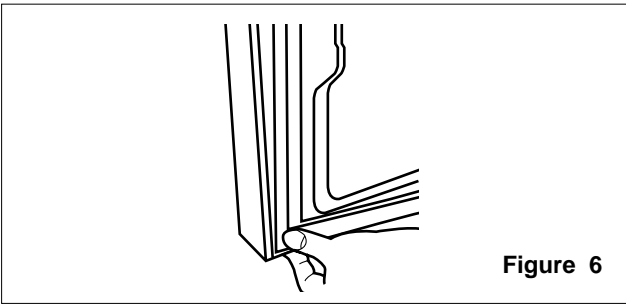

Figure 6

3. Replace door frame cover

Starting at top of cover and working down, snap cover back into door.

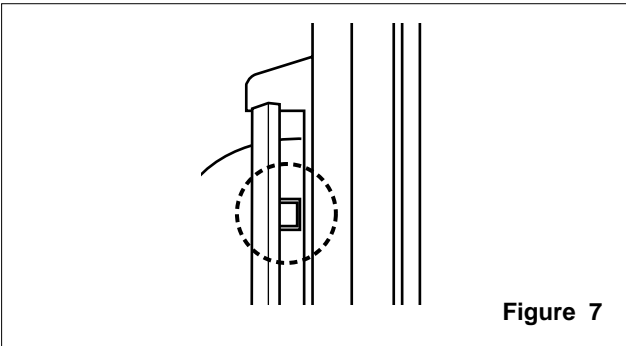

Figure 7

3-3 TO REMOVE THE DISPENSER

1. Use fiat tip screwdriver to pry back hooks on bottom underside of cover dispenser.

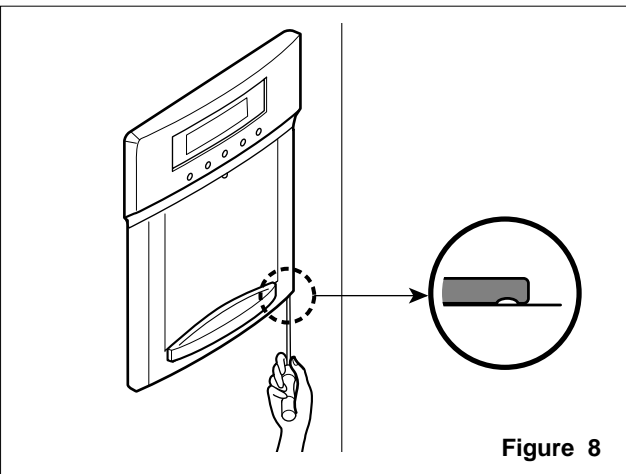

Figure 8

2. Pry off cover dispenser.

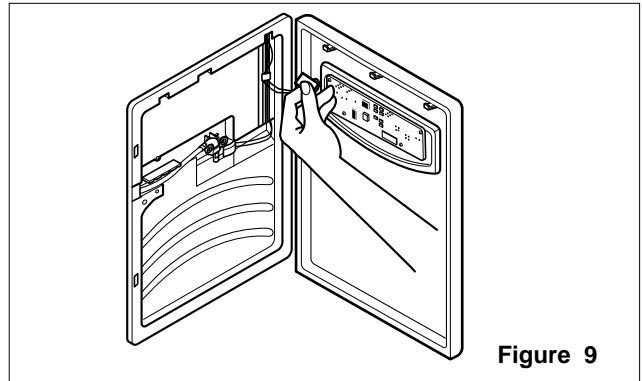

Figure 9

Disconnect wire harness.

3. Replace cover dispenser in opposite manner and order of removal.

3-4 DOOR ALIGNMENT

If the space between your doors is uneven, follow the instructions below to align the doors:

1. With one hand, lift up the door you want to raise at middle hinge.
2. With other hand, use pliers to insert snap ring as shown.
3. Insert additional snap rings until the doors are aligned. (Three snap rings are provided with unit.)

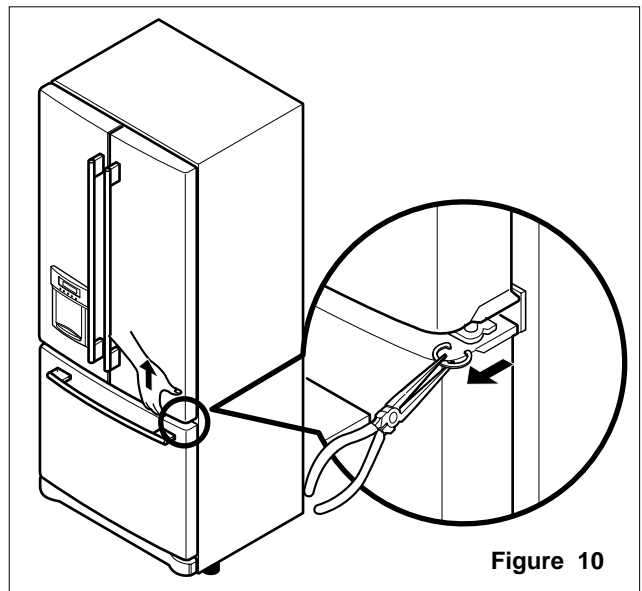

Figure 10

3-5 FAN AND FAN MOTOR

1. Remove the freezer shelf. (If your refrigerator has an icemaker, remove the icemaker first)
2. Remove the plastic guide for slides on left side by unscrewing phillips head screws.
3. Remove the grille by removing one screw and pulling the grille forward.
4. Remove the Fan Motor assembly by loosening 2 screws and disassembling the shroud.
5. Pull out the fan and separate the Fan Motor and Bracket.

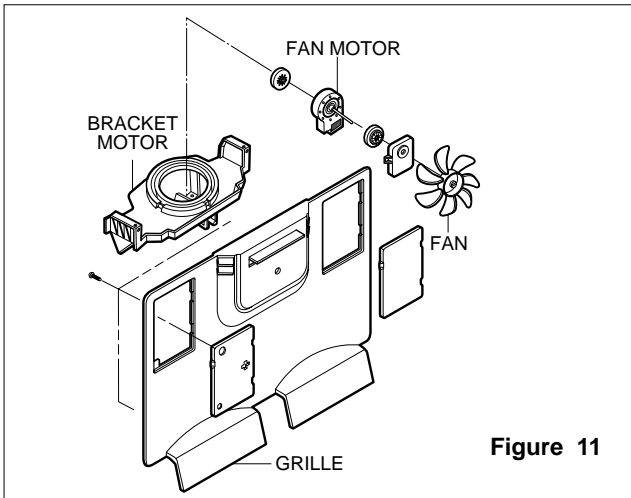

Figure 11

3-6 DEFROST CONTROL ASSEMBLY

Defrost Control assembly consists of Defrost Sensor and FUSE-M.

The Defrost Sensor works to defrost automatically. It is attached to the metal side of the Evaporator and senses its temperature. At 72°C, it turns the Defrost Heater off.

Fuse-M is a safety device for preventing over-heating of the Heater when defrosting.

1. Pull out the grille assembly. (Figure 12)
2. Separate the connector with the Defrost Control assembly and replace the Defrost Control assembly after cutting the Tie Wrap. (Figure 13)

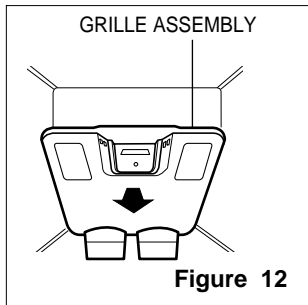

Figure 12

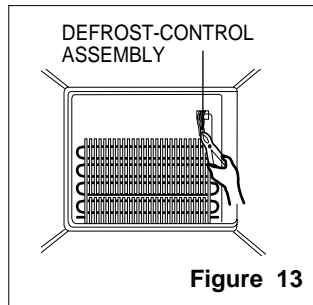

Figure 13

3-7 LAMP

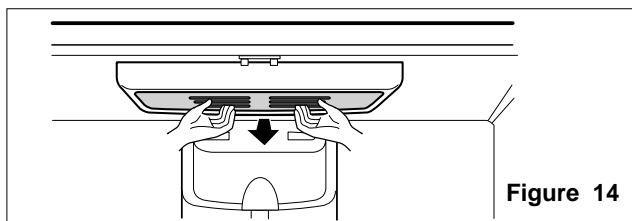

Figure 14

3-7-1 Refrigerator Compartment Lamp

1. Unplug the power cord from the outlet.
2. Remove refrigerator shelves.
3. Release the hooks on both ends of the lamp shield and pull the shield downward to remove it.
4. Turn the lamp counterclockwise.
5. Assembly is the reverse of disassembly. Replacement bulb must be the same specification as the original (Max. 60 W2EA).

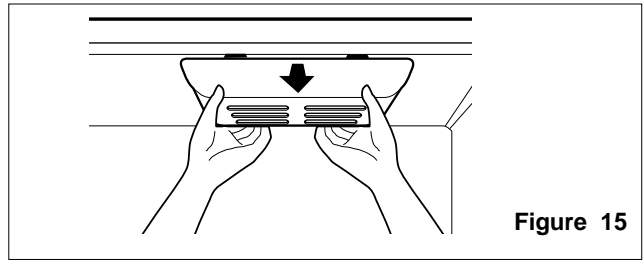

Figure 15

3-7-2 Freezer Compartment Lamp

1. Unplug refrigerator or disconnect power.
2. Reach behind light shield to remove bulb.
3. Replace bulb with a 60-watt appliance bulb.
4. Plug in refrigerator or reconnect power.

3-8 CONTROL BOX-REFRIGERATOR

1. First, remove all shelves in the refrigerator, then remove the Refrigerator control Box by loosening 2 screws.

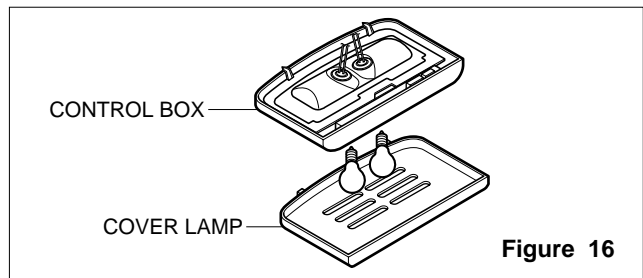

Figure 16

2. Remove the Refrigerator Control Box by pulling it downward.
3. Disconnect the lead wire on the right position and separate the lamp sockets.

3-9 MULTI DUCT

1. Remove the upper and lower Caps by using a flat screwdriver, and remove 2 screws. (Figure 17)
2. Disconnect the lead wire on the bottom position.

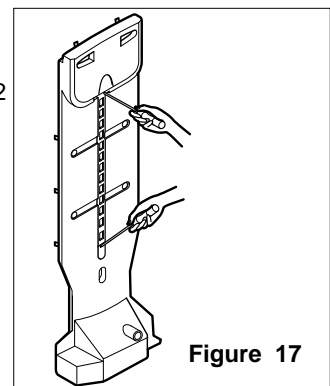

Figure 17

4. ADJUSTMENT

4-1 COMPRESSOR

4-1-1 Role

The compressor intakes low temperature and low pressure gas from the evaporator of the refrigerator and compresses this gas to high-temperature and high-pressure gas. It then delivers the gas to the condenser.

4-1-2 Composition

The compressor includes overload protection. The PTC starter and OLP (overload protector) are attached to the outside of the compressor. Since the compressor is manufactured to tolerances of 1 micron and is hermetically sealed in a dust and moisture-free environment, use extreme caution when repairing it.

4-1-3 Note for Usage

- (1) Be careful not to allow over-voltage and over-current.
- (2) If compressor is dropped or handled carelessly, poor operation and noise may result.
- (3) Use proper electric components appropriate to the Particular Compressor in your product.
- (4) Keep Compressor dry.
If the Compressor gets wet (in the rain or a damp environment) and rust forms in the pin of the Hermetic Terminal, poor operation and contact may result.
- (5) When replacing the Compressor, be careful that dust, humidity, and soldering flux don't contaminate the inside of the compressor. Contamination in the cylinder may cause noise, improper operation or even cause it to lock up.

4-2 PTC-STARTER

4-2-1 Composition of PTC-Starter

- (1) PTC (Positive Temperature Coefficient) is a no-contact semiconductor starting device which uses ceramic material consisting of BaTiO₃.
- (2) The higher the temperature is, the higher the resistance value. These features are used as a starting device for the Motor.

4-2-2 Role of PTC-Starter

- (1) The PTC is attached to the Sealed Compressor and is used for starting the Motor.
- (2) The compressor is a single-phase induction motor. During the starting operation, the PTC allows current flow to both the start winding and main winding.

4-2-3 PTC-Applied Circuit Diagram

● Starting Method for the Motor

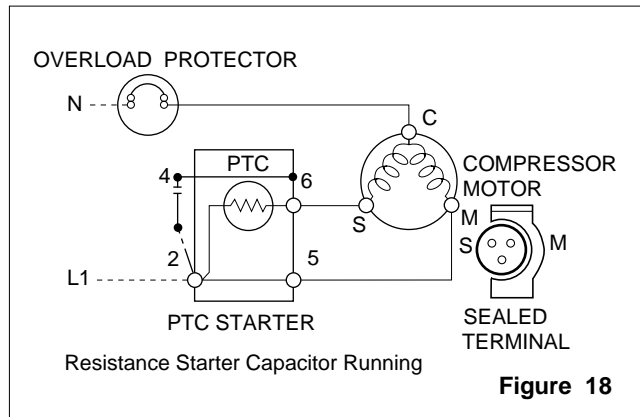

4-2-4 Motor Restarting and PTC Cooling

- (1) It requires approximately 5 minutes for the pressure to equalize before the compressor can restart.
- (2) The PTC device generates heat during operation. Therefore, it must be allowed to cool before the compressor can restart.

4-2-5 Relation of PTC-Starter and OLP

- (1) If the compressor attempts to restart before the PTC device is cooled, the PTC device will allow current to flow only to the main winding.
- (2) The OLP will open because of the over current condition. This same process will continue (3 to 5 times) when the compressor attempts to restart until the PTC device has cooled. The correct OLP must be properly attached to prevent damage to the compressor.

Parts may appear physically identical but could have different electrical ratings. Replace parts by part number and model number. Using an incorrect part could result in damage to the product, fire, injury, or possibly death.

4-2-6 Note for Using the PTC-Starter

- (1) Be careful not to allow over-voltage and over-current.
- (2) Do not drop or handle carelessly.
- (3) Keep away from any liquid.
If liquid such as oil or water enters the PTC, PTC materials may fail due to breakdown of their insulating capabilities.
- (4) If the exterior of the PTC is damaged, the resistance value may be altered. This can cause damage to the compressor and result in a no-start or hard-to-start condition.
- (5) Always use the PTC designed for the compressor and make sure it is properly attached to the compressor. Parts may appear physically identical but could have different electrical ratings. Replace parts by part number and model number. Using an incorrect part could result in damage to the product, fire, injury, or possibly death.

4-3 OLP (OVERLOAD PROTECTOR)

4-3-1 Definition of OLP

- (1) OLP (OVERLOAD PROTECTOR) is attached to the Compressor and protects the Motor by opening the circuit to the Motor if the temperature rises and activating the bimetal spring in the OLP.
- (2) When high current flows to the Compressor motor, the Bimetal works by heating the heater inside the OLP, and the OLP protects the Motor by cutting off the current flowing to the Compressor Motor.

4-3-2 Role of the OLP

- (1) The OLP is attached to the Sealed Compressor used for the Refrigerator. It prevents the Motor Coil from being started in the Compressor.
- (2) For normal operation of the OLP, do not turn the Adjust Screw of the OLP in any way.

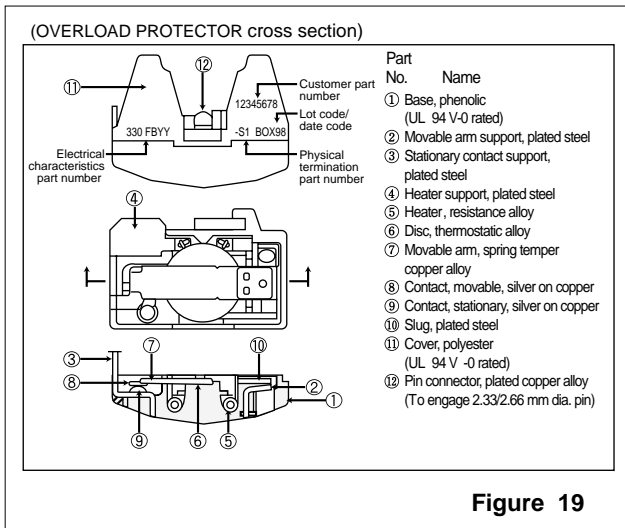
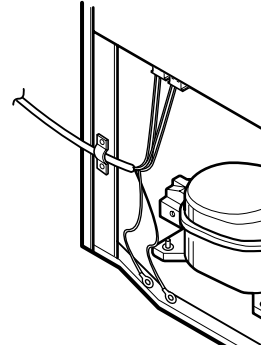
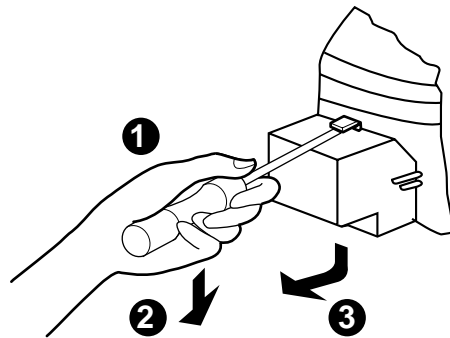

Figure 19

4-4 TO REMOVE THE COVER PTC



- (1) Remove the Cover Back M/C.
- (2) Disconnect two housing upper side of comp connected in.
- (3) Loosen two screws on comp base.



- (4) Use a L-shaped flap tool to pry off the cover.
- (5) Assembly in reverse order of disassembly.

5. CIRCUIT DIAGRAM

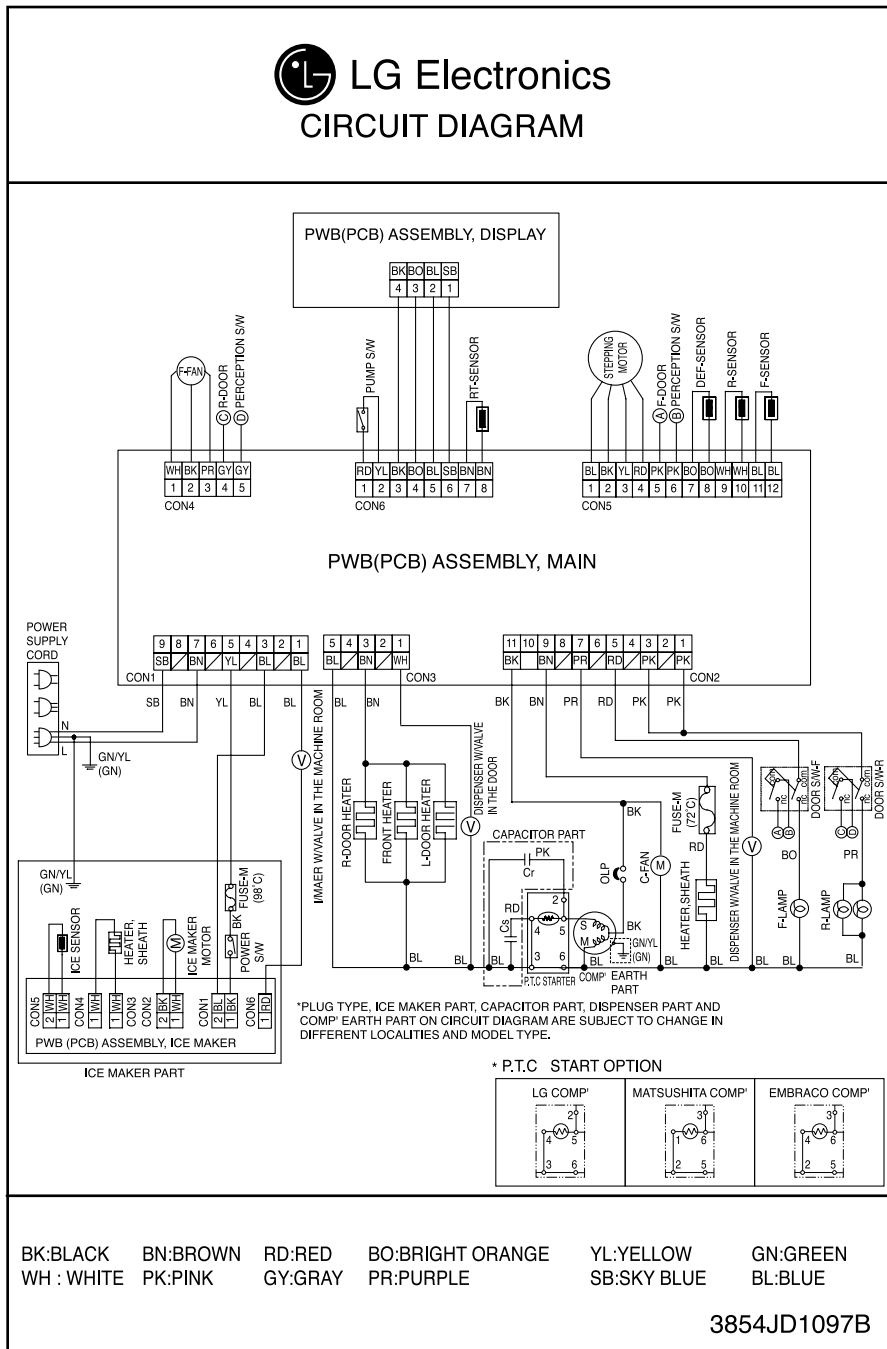
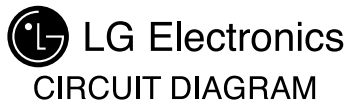

6. TROUBLESHOOTING

6-1 COMPRESSOR AND ELECTRIC COMPONENTS

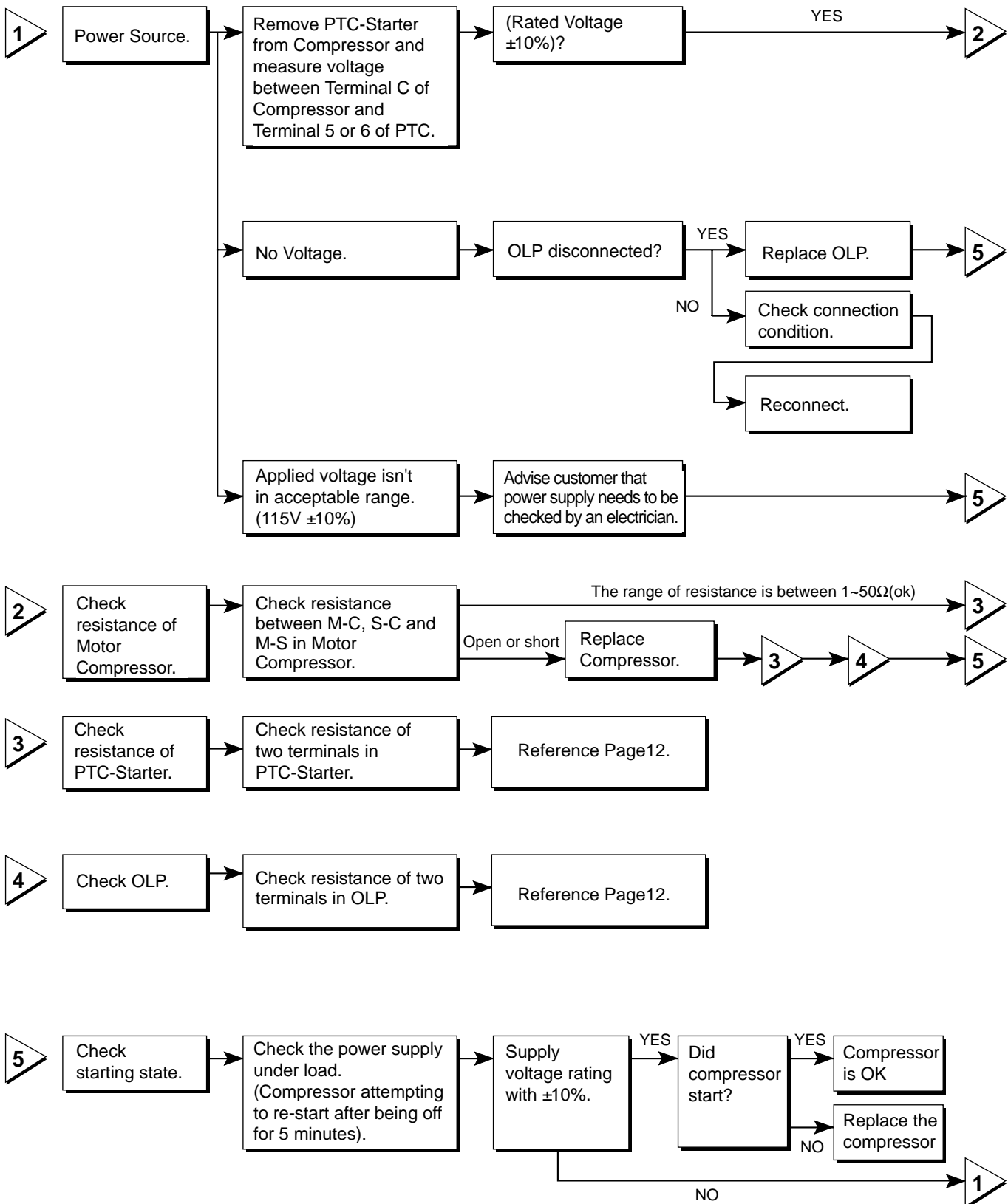

6-2 PTC AND OLP

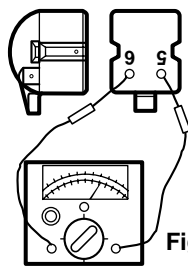
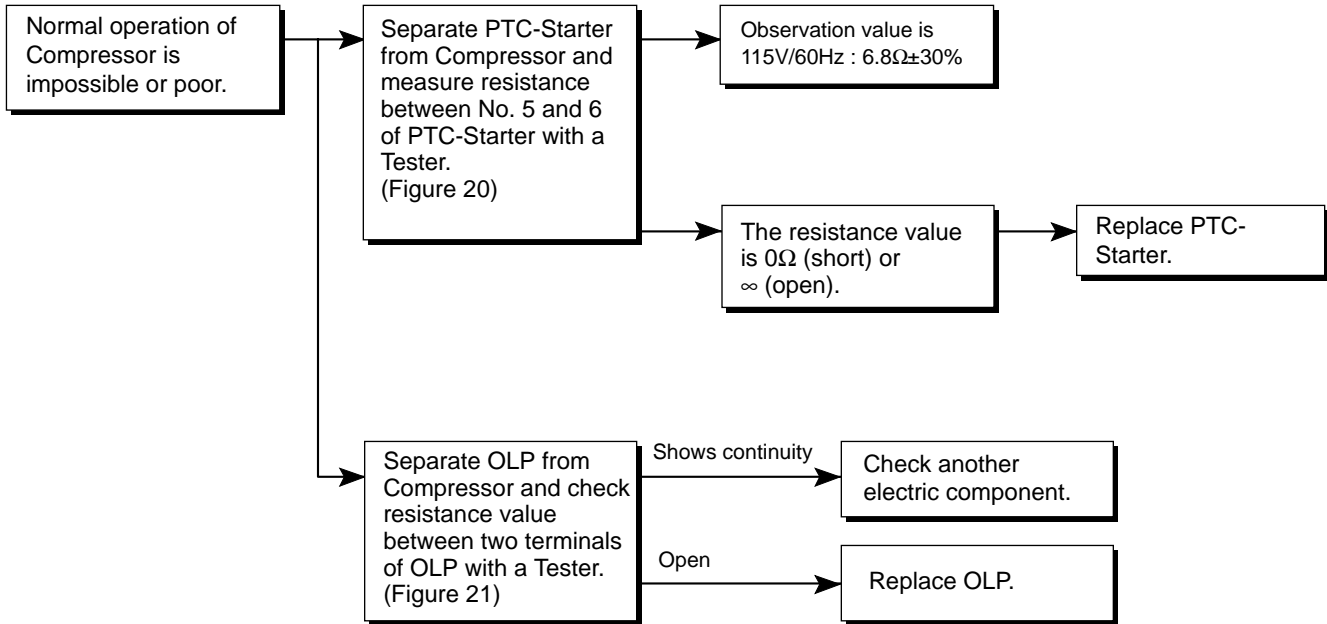

Figure 20

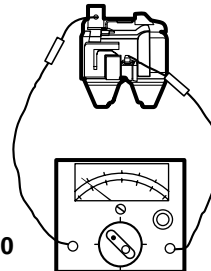
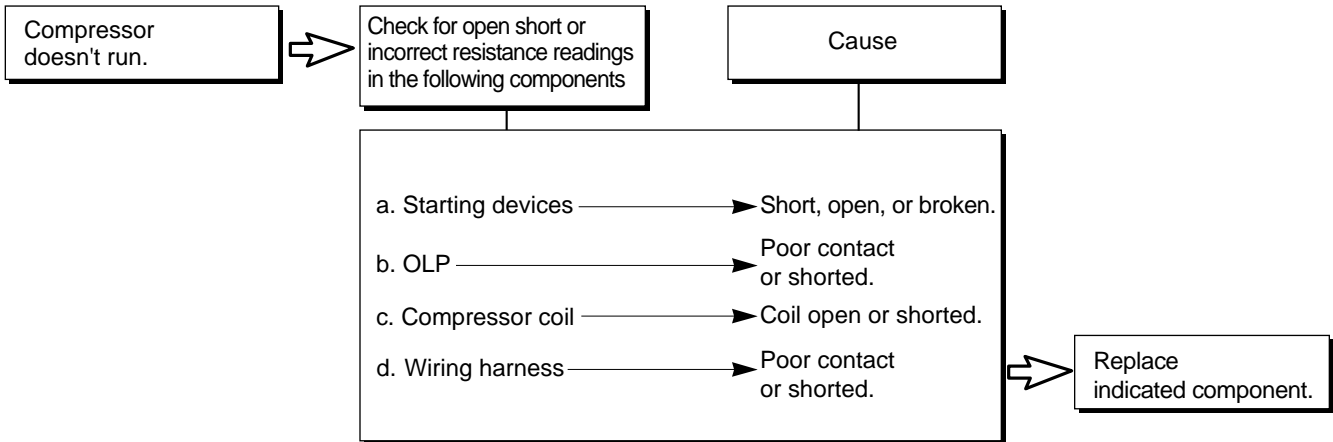

Figure 21

6-3 OTHER ELECTRICAL COMPONENTS

▼ Not cooling at all



▼ Poor cooling performance

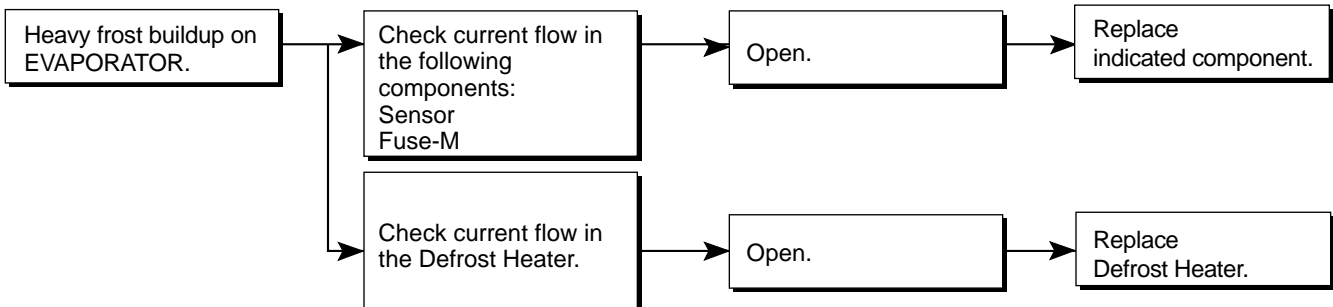
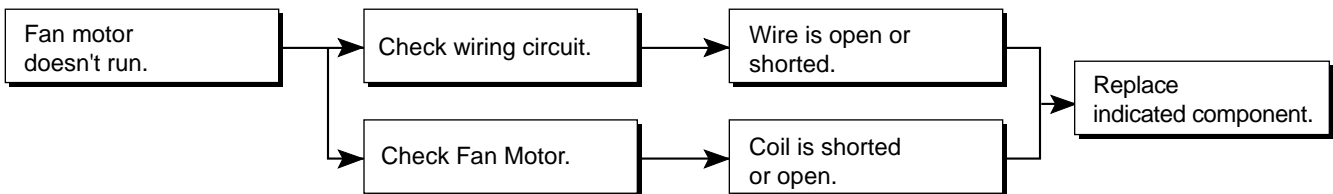
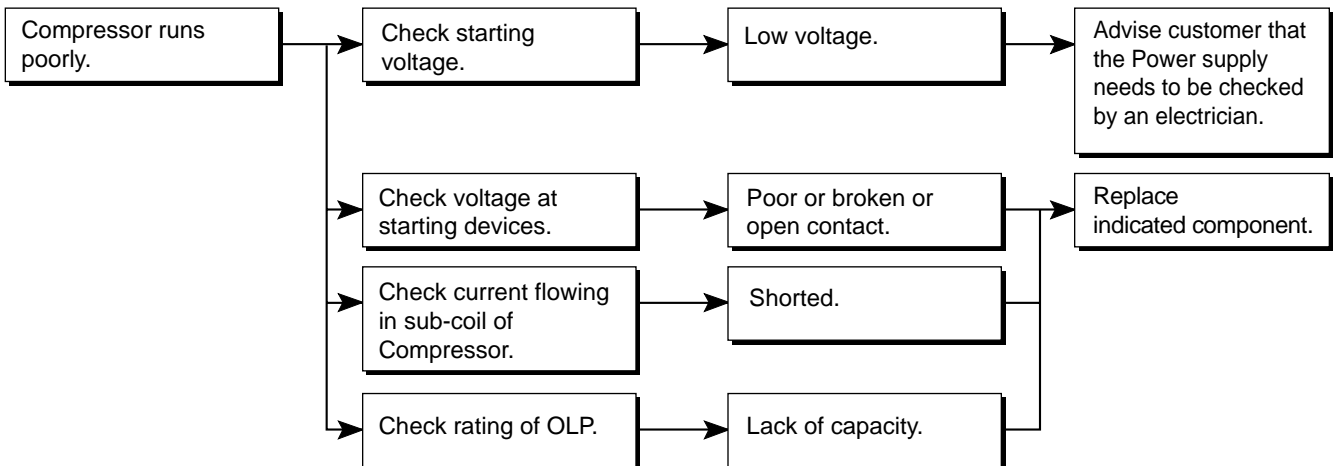

6-4 SERVICE DIAGNOSIS CHART

COMPLAINT	POINTS TO BE CHECKED	REMEDY
No Cooling.	<ul style="list-style-type: none"> • Is the power cord unplugged from the outlet? • Check if the power switch is set to OFF. • Check if the fuse of the power switch is shorted. • Measure the voltage of the power outlet. 	<ul style="list-style-type: none"> • Plug into the outlet. • Set the switch to ON. • Replace the fuse. • If the voltage is low, correct the wiring.
Cools poorly.	<ul style="list-style-type: none"> • Check if the unit is placed too close to the wall. • Check if the unit is placed too close to the stove, gas cooker, or in direct sunlight. • Is the ambient temperature too high or the room door closed? • Check if food put in the refrigerator is hot. • Did you open the door of the unit too often or check if the door is sealed properly? • Check if the Control is set to Warm position. 	<ul style="list-style-type: none"> • Place the unit about 4 inches (10 cm) from the wall. • Place the unit away from these heat sources. • Lower the ambient temperature. • Put in foods after they have cooled down. • Don't open the door too often and close it firmly. • Set the control to Recommended position.
Food in the Refrigerator is frozen.	<ul style="list-style-type: none"> • Is food placed in the cooling air outlet? • Check if the control is set to colder position. • Is the ambient temperature below 41°F(5°C)? 	<ul style="list-style-type: none"> • Place foods in the high-temperature section. (front part) • Set the control to Recommended position. • Set the control to Warm position.
Condensation or ice forms inside the unit.	<ul style="list-style-type: none"> • Is liquid food sealed? • Check if food put in the refrigerator is hot. • Did you open the door of the unit too often or check if the door is sealed properly? 	<ul style="list-style-type: none"> • Seal liquid foods with wrap. • Put in foods after they have cooled down. • Don't open the door too often and close it firmly.
Condensation forms in the Exterior Case.	<ul style="list-style-type: none"> • Check if the ambient temperature and humidity of the surrounding air are high. • Is there a gap in the door gasket? 	<ul style="list-style-type: none"> • Wipe moisture with a dry cloth. It will disappear in low temperature and humidity. • Fill up the gap.
There is abnormal noise.	<ul style="list-style-type: none"> • Is the unit positioned in a firm and even place? • Are any unnecessary objects placed in the back side of the unit? • Check if the Drip Tray is not firmly fixed. • Check if the cover of the compressor enclosure in the lower front side is taken out. 	<ul style="list-style-type: none"> • Adjust the Leveling Screw, and position the refrigerator in a firm place. • Remove the objects. • Fix the Drip Tray firmly in the original position. • Place the cover in its original position.
Door does not close well.	<ul style="list-style-type: none"> • Check if the door gasket is dirty with an item like juice. • Is the refrigerator level? • Is there too much food in the refrigerator? 	<ul style="list-style-type: none"> • Clean the door gasket. • Position in a firm place and level the Leveling Screw. • Make sure food stored in shelves does not prevent the door from closing.
Ice and foods smell unpleasant.	<ul style="list-style-type: none"> • Check if the inside of the unit is dirty. • Are foods with a strong odor unwrapped? • The unit smells of plastic. 	<ul style="list-style-type: none"> • Clean the inside of the unit. • Wrap foods that have a strong odor. • New products smell of plastic, but this will go away after 1-2 weeks.

● Other possible problems:

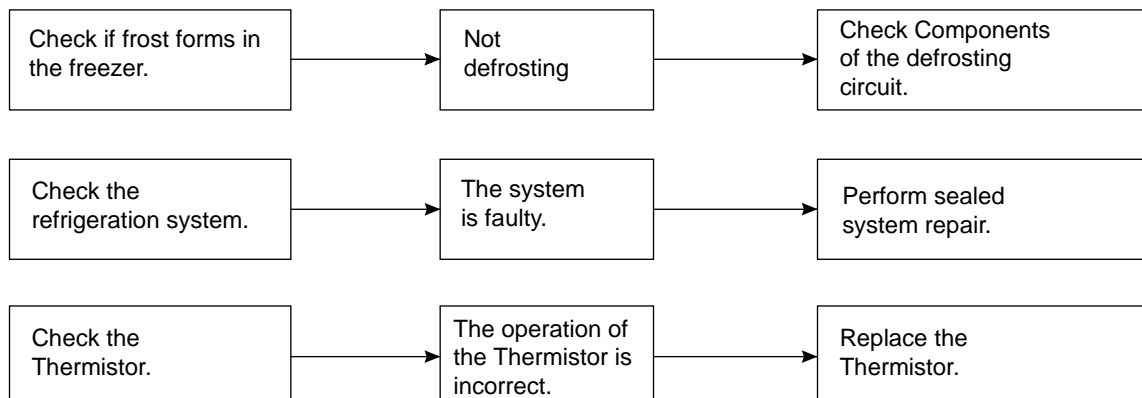

6-5 REFRIGERATION CYCLE

▼ Troubleshooting Chart

CAUSE		STATE OF THE UNIT	STATE OF THE EVAPORATOR	TEMPERATURE OF THE COMPRESSOR	REMARKS
LEAKAGE	PARTIAL LEAKAGE	Freezer compartment and Refrigerator don't cool normally.	Low flowing sound of Refrigerant is heard and frost forms in inlet only.	A little higher than ambient temperature.	<ul style="list-style-type: none"> Refrigerant level is low due to a leak. Normal cooling is possible by restoring the normal amount of refrigerant and repairing the leak.
	COMPLETE LEAKAGE	Freezer compartment and Refrigerator don't cool normally.	Flowing sound of refrigerant is not heard and frost isn't formed.	Equal to ambient temperature.	<ul style="list-style-type: none"> No discharging of Refrigerant. Normal cooling is possible by restoring the normal amount of refrigerant and repairing the leak.
CLOGGED BY DUST	PARTIAL CLOG	Freezer compartment and Refrigerator don't cool normally.	Flowing sound of refrigerant is heard and frost forms in inlet only.	A little higher than ambient temperature.	<ul style="list-style-type: none"> Normal discharging of the refrigerant. The capillary tube is faulty.
	WHOLE CLOG	Freezer compartment and Refrigerator don't cool.	Flowing sound of refrigerant is not heard and frost isn't formed.	Equal to ambient temperature.	<ul style="list-style-type: none"> Normal discharging of the Refrigerant.
MOISTURE CLOG		Cooling operation stops periodically.	Flowing sound of refrigerant is not heard and frost melts.	Lower than ambient temperature.	<ul style="list-style-type: none"> Cooling operation restarts when heating the inlet of the capillary tube.
DEFECTIVE COMPRESSION	COMP-RESSION	Freezer and Refrigerator don't cool.	Low flowing sound of refrigerant is heard and frost forms in inlet only.	A little higher than ambient temperature.	<ul style="list-style-type: none"> Low pressure at high side of compressor due to low refrigerant level.
	NO COMP-RESSION	No compressing operation.	Flowing sound of refrigerant is not heard and there is no frost.	Equal to ambient temperature.	<ul style="list-style-type: none"> No pressure in the high pressure part of the compressor.

6-5-1 SEALED SYSTEM DIAGNOSIS

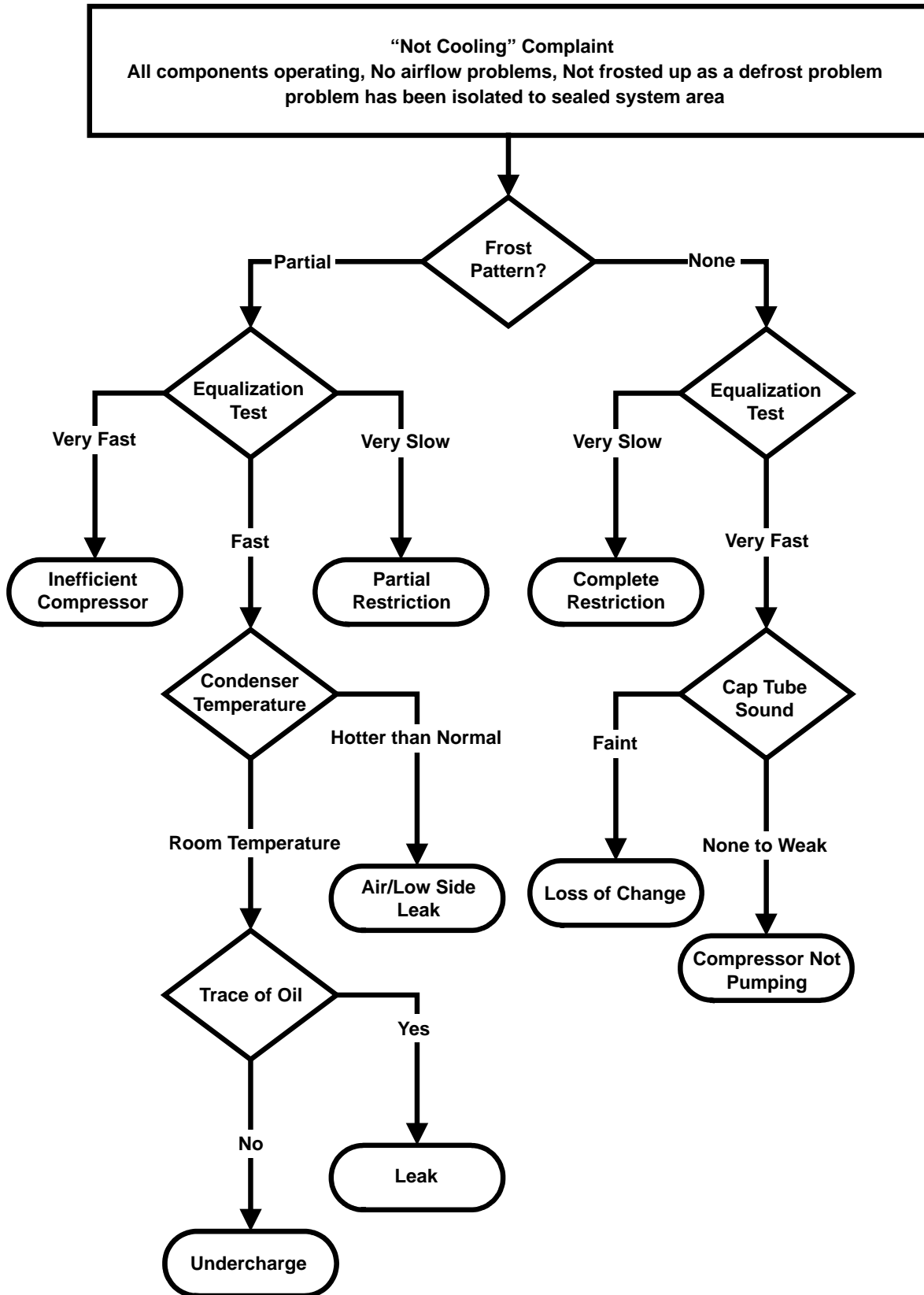

(The equalization test is trying to restart a compressor using a start kit after it has been operating.)

7. OPERATION PRINCIPLE AND REPAIR METHOD OF ICEMAKER

7-1 OPERATION PRINCIPLE

7-1-1 Operation Principle of IceMaker

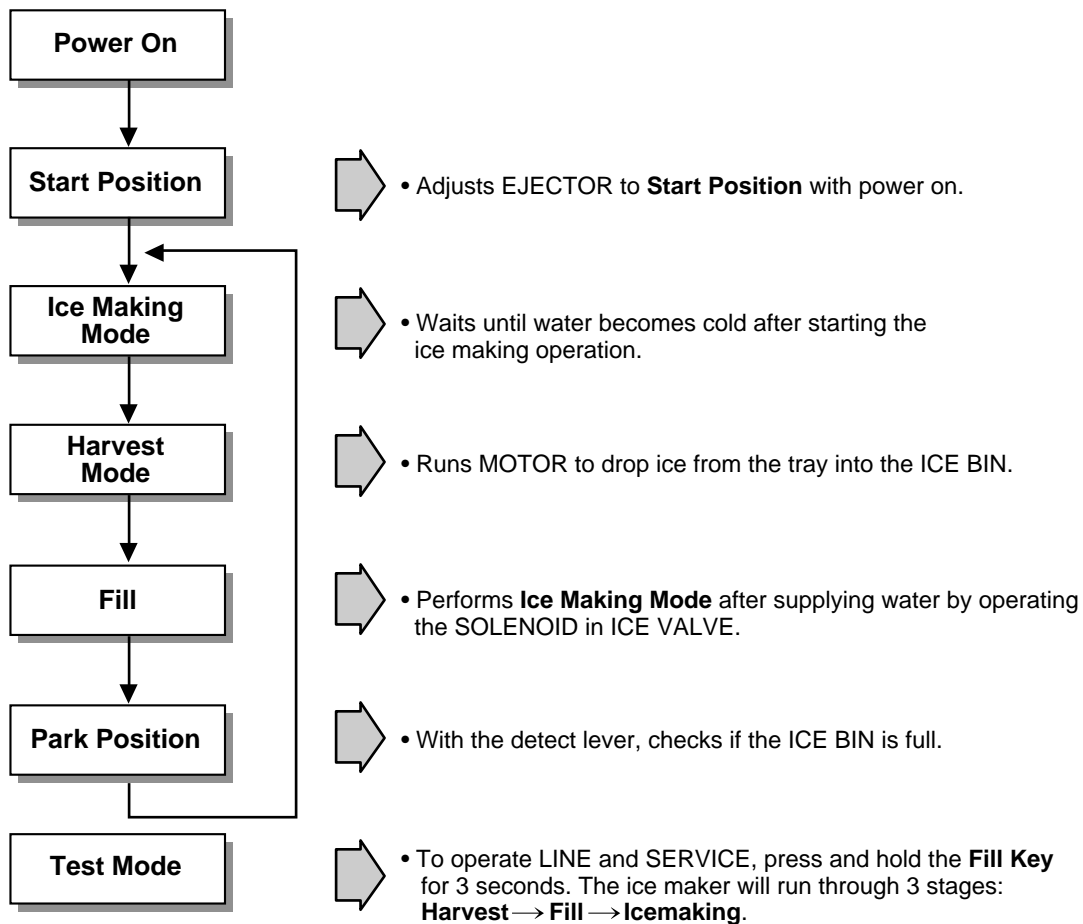

1. Turning the Icemaker stop switch off (O) stops the ice making function.
2. Setting the Icemaker switch to OFF and then turning it back on will reset the icemaker control.

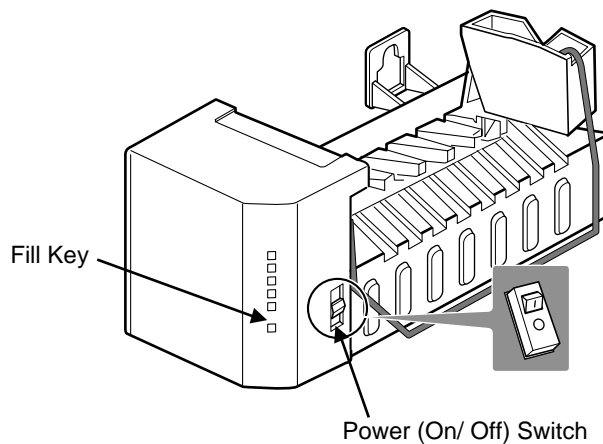

7-2 ICE MAKER FUNCTIONS

7-2-1 Start Position

1. After POWER OFF or Power Outage, check the EJECTOR's position with MICOM initialization to restart.
2. How to check if it is in place:
 - Check **HIGH/LOW** signals from HALL SENSOR in MICOM PIN.
3. Control Method to check if it is in place:
 - (1) EJECTOR is in place,
 - It is an initialized control, so the mode can be changed to ice making control.
 - (2) EJECTOR isn't in place:
 - A. If EJECTOR is back in place within 2 minutes with the motor on, it is being initialized. If not, go to Step B.
 - B. If EJECTOR is back in place within 18 minutes after the heater turns from ON to OFF, it is being initialized. If not, it is not functioning. Repeat Step B with Heater and Motor off.

7-2-2 Ice Making Mode

1. Ice Making refers to the freezing of supplied water in the ice trays. Complete freezing is assured by measuring the temperature of the Tray with Ice-Making SENSOR.
2. Ice Making starts after completion of the water fill operation.
3. The Ice Making function is completed when the sensor reaches 19°F(-7°C), 60 to 240 minutes after starting.
4. If the temperature sensor is defective, the ice-making function will be completed in 4 hours.

NOTE : After Icemaker Power is ON, the Icemaker heater will be on for test for 9 sec.

7-2-3 Harvest Mode

1. Harvest (Ice removing) refers to the operation of dropping cubes into the ice bin from the tray when ice-making has completed.
2. Harvest mode:
 - (1) The Heater is ON for 30 seconds, then the motor starts.
 - (2) After performing Step 1 (the Heater is turned OFF), the Ejector will be back in place within 18 minutes. (Hall SENSOR sign = 0V). Ice removal is then complete. Then the Ice Maker cycles to the Fill Mode. The water supply fails to start, it is not functioning. Put the Heater and Motor in the off position. Restart every 2 hours. (Refer to fig.1)



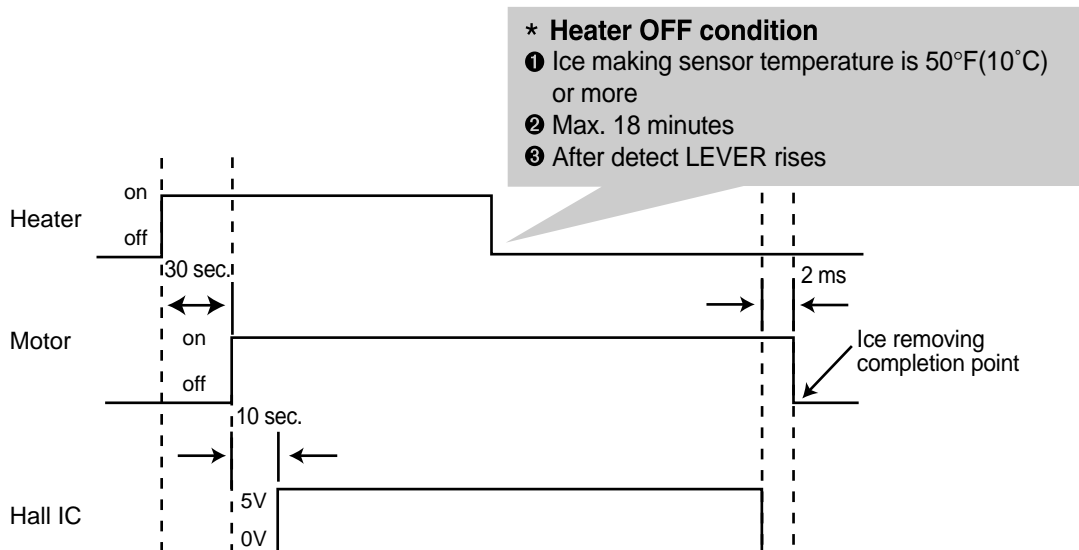

NOTE : If the motor malfunctions and starts before the detect lever rises, MICOM regards the Ice-Removing phase as completed. Water then starts flowing. To prevent this, MICOM doesn't switch to water-supply mode, but restarts the ice-removing mode. If this happens 3 times, the motor is malfunctioning and you should stop the loads (Heater, Motor). Then restart the Ice-Removing mode every 2 hours. (See Step 2 above.)



7-2-4 Fill / Park Position

1. Once a normal harvest mode has been completed, the water solenoid will be activated.
2. The amount of water is adjusted by pressing the Fill Key repeatedly. This changes the time allowed for fill as illustrated in the table below.





<Water supply amount TABLE>

STAGE	TIME TO SUPPLY	INDICATIONS	REMARKS
1	6 sec.		<p>The water amount will vary depending on the water control Switch setting, as well as the water pressure of the connected water line.</p>
2	6.5 sec.		
3	7 sec.		
4	7.5 sec.		
5	8 sec.		

7-2-5 Function TEST



1. This is a compulsory operation for TEST, SVC, cleaning, etc. It is operated by pressing and holding the Fill Key for 3 seconds.
2. The test works only in the Ice Making Mode. It cannot be entered from the Harvest or Fill mode. (If there is an ERROR, it can only be checked in the TEST mode.)
3. **Caution!** If the test is performed before water in the Maker is frozen, the Ejector will pass through the water. When the Fill mode begins (Stage 4), unless the water supply has been shut off, added water will overflow into the ice bin. If the control doesn't operate normally in the TEST mode, check and repair as needed.
4. After water is supplied, the normal CYCLE is followed: **ice making** → **Harvest** → **Fill** → **Park Position**.
5. Five seconds after Stage 5 is completed, the Ice Maker returns to MICOM control. The time needed to supply water resets to the pre- test setting.

<Diagnosis TABLE>

STAGE	ITEMS	INDICATOR	REMARKS
1	HEATER		Five seconds after heater starts, heater will go off if temperature recorded by sensor is 10°C or lever is in up position.
2	MOTOR		Five seconds after heater starts, you can confirm that motor is moving.
3	HALL IC I (detection of position)		You can confirm Hall Ic detection of position.
4	VALVE		Two seconds after detection of initial position, you can confirm that valve is on.
5	HALL IC II (detection of full-filled Ice)		You can check whether hall is sensing Full ice condition. (If there is a full-filled error, the fifth LED is not on.)
6	Reset	Return to Status prior to TEST MODE	Five seconds after fifth stage is completed, the icemaker resets to initial status.

7-3 DEFECT DIAGNOSIS FUNCTION

7-3-1 ERROR CODES shown on Ice Maker water supply control panel

NO	DIVISION	INDICATOR	CONTENTS	REMARKS
1	Normal	Mark time to supply	None	Display switch operates properly
2	Ice-Making Sensor malfunction		Open or short-circuited wire	Make sure that the wire on each sensor is connected.
3	Ice Maker Kit malfunction		When ejector blades don't reach park position over 18 minutes after Harvest Mode starts.	Check HALL IC/MOTOR/HEATER/RELAY

ERROR indicators in table can be checked only in TEST mode.

8. DESCRIPTION OF FUNCTION & CIRCUIT OF MICOM

8-1 FUNCTION

8-1-1 Function

- When the appliance is plugged in, it is set to 37°F for Refrigerator and 0°F for freezer.
You can adjust the Refrigerator and the Freezer control temperature by pressing the ADJUST button.
- When the power is initially applied or restored after a power failure, it is automatically set to “37” & “0”.

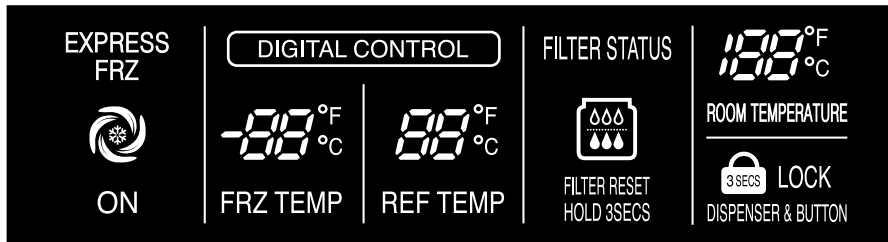

8-1-2 How to Toggle the Display between °F & °C

- The display temperature mode can be changed from °F to °C or °C to °F by pressing and holding the FRZ TEMP and the REF TEMP keys at the same time for over one second.
- The initial setting is °F. Whenever the mode is changed, the LED lights are changed.

8-1-3 Lock function (dispenser and display button lock)

- When the refrigerator is first turned on, the buttons are not locked. The display panel shows the padlock unlocked icon.
- To lock the display, the dispenser, and the control panel, press and hold the LOCK button for 3 seconds. The locked padlock icon is displayed with the word "LOCK" printed beside it.
- The LOCK button is the only control feature that remains active in the locked state. The buzzer sound, other control buttons, and the dispenser are deactivated.
- To release from the locked state, press and hold the LOCK button again for 3 seconds.

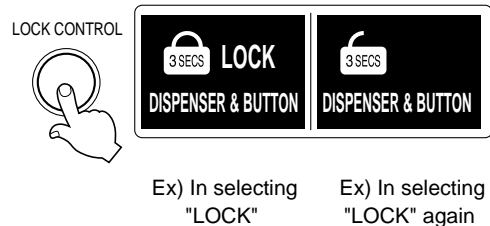

8-1-4 Filter condition display function

- There is a replacement indicator light for the water filter cartridge on the dispenser.
- Water filter needs replacement once six months or about 28,000 seconds of using water filter.
- Water filter light and “FILTER RESET HOLD 3 SECS” text turn on to tell you need to replace the filter soon.
- After replace the filter, press and hold the lock button more than 3 seconds.
Then water filter light and “FILTER RESET HOLD 3 SECS” text turn off with reset status.

Classification	In initial Power On / Filter RESET	Replace indicator light on
Filter Status Display		

8-1-5 Express freezing selection

Please select this function for quick freezing.

- Function is repeated following below whenever pressing Express FRZ button.
- Expressing freezer function automatically turns off after a fixed time passes.



8-1-6 CONTROL OF FREEZER FAN MOTOR

1. Freezer fan motor has high and standard speeds.
2. High speed is used at power-up, for express freezing, and when refrigerator is overloaded.
Standard speeds is used for general purposes.
3. To improve cooling speed, the RPM of the freezer fan motor change from normal speed to high.
4. High speed (2700RPM) : Initial power on or load corresponding operation, express freezing.
Normal speed (2400RPM) : General working conditions.
5. Fan motor stops when refrigerator or freezer door opens.

8-1-7 EXPRESS FREEZING

1. The purpose of this function is to intensify the cooling speed of freezer and to increase the amount of ice.
2. Whenever selection switch is pressed, selection/release, the LED will turn ON or OFF.
3. If there is a power outage and the refrigerator is powered on again, EXPRESS FREEZING will be canceled.
4. To activate this function, press the Express Freezing key and the LED will turn ON. This function will remain activated for 24 hrs. The first three hours the compressor and Freezer Fan will be ON. The next 21 hours the freezer will be controlled at the lowest temperature. After 24 hours or if the Express Freezing key is pressed again, the freezer will return to its previous temperature.
5. During the first 3 hours:
 - (1) Compressor and freezer fan (HIGH RPM) run continuously.
 - (2) If a defrost cycle begins during the first 90 minutes of Express Freezing, the Express Freeze cycle will complete its cycle after defrosting has ended.
If the defrost cycle begins when Express Freeze has run for more than 90 minutes, Express Freeze will run for two hours after the defrost is completed.
 - (3) If EXPRESS FREEZING is pressed during defrost, EXPRESS FREEZING LED is on but this function will start seven minutes after defrost is completed and it shall operate for three hours.
 - (4) If EXPRESS FREEZING is selected within seven minutes after compressor has stopped, the compressor (compressor delays seven minutes) shall start after the balance of the delay time.
 - (5) The fan motor in the freezer compartment runs at high speed during EXPRESS FREEZING .
6. For the rest of the 21 hours, the freezer will be controlled at the lowest temperature.

8-1-8 REFRIGERATOR LAMP AUTO OFF

1. To avoid heat damage caused by the lamp, it is turned off automatically when the refrigerator door is open for more than 7 minutes.

8-1-9 Alarm for Open Door

1. This feature sounds a buzzer when the freezer or refrigerator door is not closed within 1 minute after it is opened.
2. One minute after the door is opened, the buzzer sounds three times each for 1/2 seconds. These tones repeat every 30 seconds.
3. The alarm is cancelled when the freezer or the refrigerator is closed while the buzzer sounds.

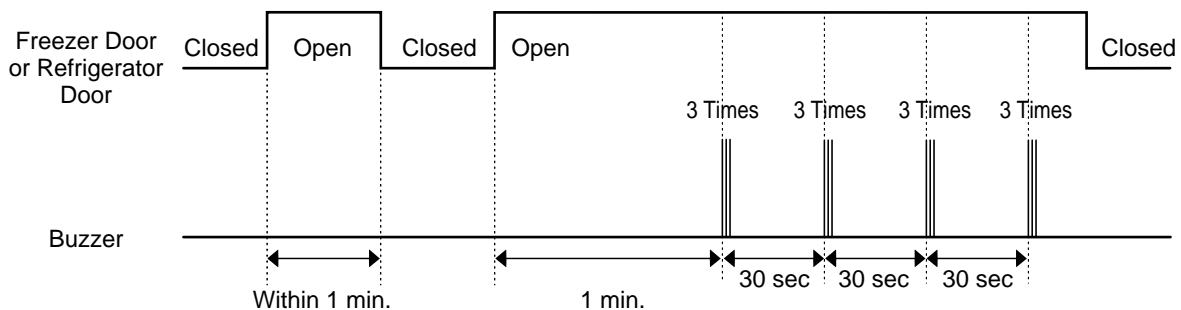

8-1-10 Buzzer Sound

When the button on the front Display is pushed, a Ding~ Dong~ sound is produced.
(Refer to the Buzzer Circuit 8-2-4 No. 3)

8-1-11 Defrosting (removing frost)

1. Defrosting starts each time the COMPRESSOR running time reaches 7 hours.
2. For initial power on or for restoring power, defrosting starts when the compressor running time reaches 4 hours.
3. Defrosting stops if the sensor temperature reaches 46.4°F(8°C) or more. If the sensor doesn't reach 46.4°F(8°C) in 2 hours, the defrost mode is malfunctioning. (Refer to the defect diagnosis function, 8-1-14.)
4. Defrosting won't function if its sensor is defective (wires are cut or short circuited)

8-1-12 Filter Replacement Indication

1. In 6 months after the UNIT (refrigerator) is power on, or after 28,000 seconds of dispenser use, the water filter Indicator LED will be ON.
2. When the water filter indicator LED is illuminated, you should change the water filter. After this, you must press the water filter button for three seconds and you will hear a ding-dong sound.
The LED will be OFF. This operation will indicate that the UNIT is reset to its initial conditions, so this process is restarted.

8-1-13 Electrical Parts Are Turned On Sequentially

Electrical parts such as COMP, defrosting heater, freezer FAN, etc. are turned on in the following order to prevent noise and parts damage. Several parts are started at the same time at initial power on and are turned off together when TEST is completed.

OPERATING		ORDERS				
Initial power on	Temperature of Defrosting Sensor is 113°F(45°C) or more (when unit is newly purchased or when moved)	POWER ON	in 1/2 second →	COMP ON	in 1/2 second →	Freezer FAN ON
	Temperature of defrosting sensor is lower than 113°F(45°C) (when power cuts, SERVICE)	POWER ON	in 1/2 second →	Defrosting heater ON	in 10 second →	Defrosting heater OFF
		in 1/2 second →	COMP ON	in 1/2 second →	Freezer FAN ON	
	Reset to normal operation from TEST MODE	Total load OFF	in 7 minute →	COMP ON	in 1/2 second →	Freezer FAN ON

8-1-14 How to show the display ON & OFF

The display can be changed from on to off mode or off to on mode by pressing and holding the EXPRESS FRZ and FRZ TEMP buttons at the same time for over five seconds.

8-1-15 Defect Diagnosis Function

1. Automatic diagnosis makes servicing the refrigerator easy.
2. When a defect occurs, the buttons will not operate; but the tones. such as ding. will sound.
3. When the defect CODE removes the sign, it returns to normal operation (RESET).
4. The defect CODE shows on the Refrigerator and Freezer Display.

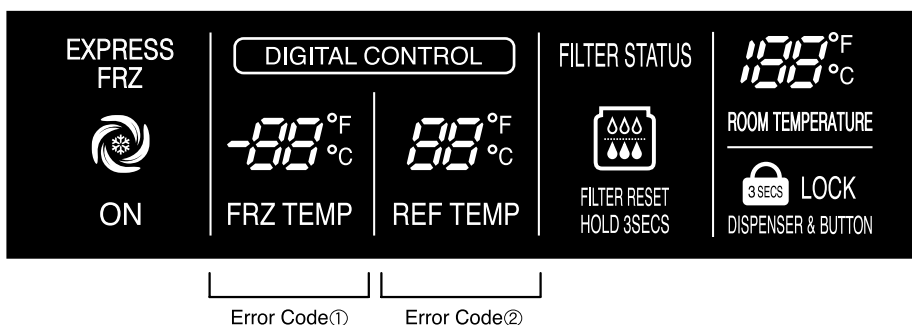

ERROR CODE on display panel

NO	ITEM	ERROR CODE		CONTENTS	REMARKS
		①	②		
1	Failure of freezer sensor	Er	FS	Cut or short circuit wire	Inspect Connecting wires on each sensor
2	Failure of Refrigerator sensor	Er	rS	Cut or short circuit wire	
3	Failure of defrost sensor	Er	dS	Cut or short circuit wire	
4	Failure of Room Temperature sensor	When Display check mode		Cut or short circuit wire	
5	Failure of defrost mode	Er	dH	When defrost sensor doesn't reach 46°F within 2 hours after starting defrost.	Snapping of defrost heater or Temperature fuse, pull-out of connector (indicated minimum 2 hours after failure occurs)
6	Failure of BLDC Fan Motor at Freezing Compartment.	Er	FF	If there is no fan motor signal for more than 65sec in operation fan motor	Poor motor, hooking to wires of fan, contact of structures to fan, snapping or short circuit of Lead wires

Note 1) Freezer room notch temperature display and refrigerator room notch temperature display (Failure code indication part) are normally indicated in abnormal ambient sensor, and “Er” indicated on the ambient temperature display.

* LED check function: If simultaneously pressing express freezer button and freezing temperature adjustment button for a second, display LED graphics on. If releasing the button, the LED graphic displays the previous status.

8-1-16 TEST Mode

1. The Test mode allows checking the PCB and the function of the product as well as finding out the defective part in case of an error.
2. The test mode is operated by pressing two buttons at Display panel.
3. While in the test mode, the function control button is not recognized, but the recognition tone (beep~) sounds.
4. After exiting the test mode, be sure to reset by unplugging and then plugging in the appliance.
5. If an error, such as a sensor failure, is detected while in the test mode, the test mode is cleared and the error code is displayed.
6. While an error code is displayed, the test mode will not be activated.

MODE	MANIPULATION	CONTENTS	REMARKS
TEST1	Push Express Freezing Key and LOCK KEY at the same time for 3 seconds OR Push TEST S/W(on the main Board) once.	1) Continuous operation of the COMPRESSOR and the Freezer fan 2) Stepping DAMPER OPEN 3) Defrosting HEATER OFF 4) DISPLAY LED all ON	
TEST2	Push Express Freezing Key and LOCK KEY at the same time for 3 seconds in TEST MODE 1 OR Push TEST S/W once in TEST MODE 1	1) Continuous operation of the COMPRESSOR and the Freezer fan 2) Stepping DAMPER CLOSE 3) Defrosting HEATER OFF 4) DISPLAY LED shows no. 2	
TEST3	Push Express Freezing Key and LOCK KEY at the same time for 3 seconds in TEST MODE 2 OR Push TEST S/W once in TEST MODE 2	1) COMPRESSOR and the Freezer fan OFF 2) Stepping DAMPER CLOSE 3) Defrosting HEATER ON 4) DISPLAY LED shows no. 3	Reset if the Temperature of the Defrosting Sensor is 46°F(8°C) or more.
Reset	Push Express Freezing Key and LOCK KEY at the same time for 3 seconds in TEST MODE 3 OR Push TEST S/W once in TEST MODE 3	Reset to the previously setting Before TEST MODE.	The compressor will Start after a 7-minute Delay.

* Freezer Fan RPM Variable Check:

In case the freezer fan is in operation when the express freezer button and freezing temp. button. Control are pressed for more than one second at the same time freezer fan RPM changes. (for example if high speed, to normal speed or if normal speed, to high speed for 30 seconds)
After 30 seconds, it turns to its original RPM.

* Demonstration MODE:

1. When the express freeze button and the refrigerator temperature control button are pushed at the same time and hold for 5 seconds or longer, it converts to demonstration mode.
2. The Display shows the Demo graphic.
3. In this status, all Loads are off (Compressor / Fan / Damper / Heater)
(Even is Demonstration Mode, the refrigerator Lamp automatic off function works normally and can be demonstrated)
4. Exit the Demo mode and reset the Display by pressing the Freezer Temp. Control button and the Refrigerator Temp. Control button for 3 seconds or longer.

8-2 PCB FUNCTION

8-2-1 Power Circuit

1. Power is supplied to the control board at pin7 and 9 od connector #1.

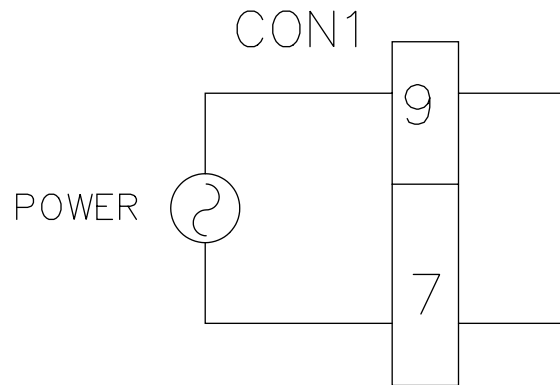

8-2-2 Load / Buzzer Drive & Open Door Detection Circuit

1. Load Drive Condition Check

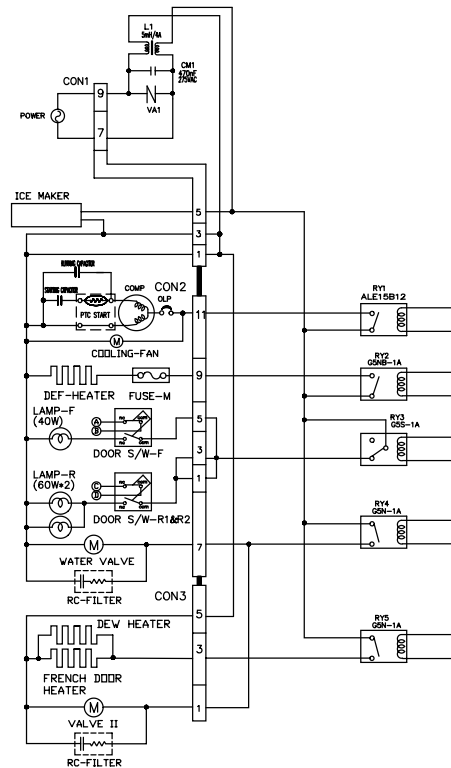

To measure outputs of the control board, check voltages between the pins for the following components:

Circuit	Pin Number	Pin Number	Output Voltage
Compressor	Con2 pin11	Con1 pin1	115 VAC
Condenser fan	Con2 pin11	Con1 pin1	115 VAC
Defrost heater	Con2 pin9	Con1 pin1	115 VAC
F,R-lamp	Con2 pin,3.5	Con1 pin1	115 VAC
Water valve	Con2 pin7	Con1 pin1	115 VAC
Dew heater	Con2 pin3	Con1 pin1	115 VAC
Water valve	Con2 pin1	Con1 pin1	115 VAC

NOTE: When the door of the freezer/refrigerator is left open for 7 minutes or longer, the lamp of the freezer/refrigerator turns.

2. Fan motor driving circuit (freezing compartment fan)

	Pin1 & 2 of con4
MOTOR OFF	2V or less
MOTOR ON	13V~15V

3. Open Door Detection Circuit Check

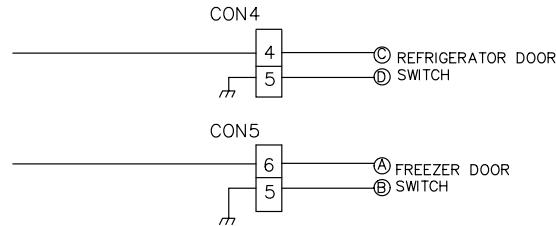

8-2-3 Temperature Sensor Circuit

Measurement Location Freezer/ Refrigerator Door	Pin 4 & 5 of con4 Ref.Door Pin 5 & 6 of con5 Fre.Door
Closed	0 V
Open	5 V

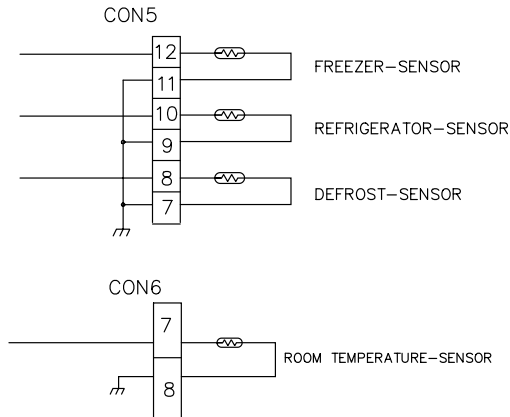

TEMPERATURE	RESISTANCE OF FREEZER SENSOR	RESISTANCE OF REFRIGERATOR & DEFROST SENSOR & ROOM SENSOR
- 20 °C (-4 °F)	22.3 KΩ	77 KΩ
- 15 °C (5 °F)	16.9 KΩ	60 KΩ
- 10 °C (14 °F)	13.0 KΩ	47.3 KΩ
- 5 °C (23 °F)	10.1 KΩ	38.4 KΩ
0 °C (32 °F)	7.8 KΩ	30 KΩ
+ 5 °C (41 °F)	6.2 KΩ	24.1 KΩ
+ 10 °C (50 °F)	4.9 KΩ	19.5 KΩ
+ 15 °C (59 °F)	3.9 KΩ	15.9 KΩ
+ 20 °C (68 °F)	3.1 KΩ	13 KΩ
+ 25 °C (77 °F)	2.5 KΩ	11 KΩ
+ 30 °C (86 °F)	2.0 KΩ	8.9 KΩ
+ 40 °C (104 °F)	1.4 KΩ	6.2 KΩ
+ 50 °C (122 °F)	0.8 KΩ	4.3 KΩ

- The resistance of the SENSOR has a ±5% common difference.
- Measure the resistance of the SENSOR after leaving it for over 3 minutes in the measuring temperature. This delay is necessary due to sensor response speed.

8-2-4 Refrigeration Compartment Stepping Motor Damper Circuit

A reversible DC motor is used to open and close the damper.

To open the damper, push test button once.

To close the damper, push test button twice.

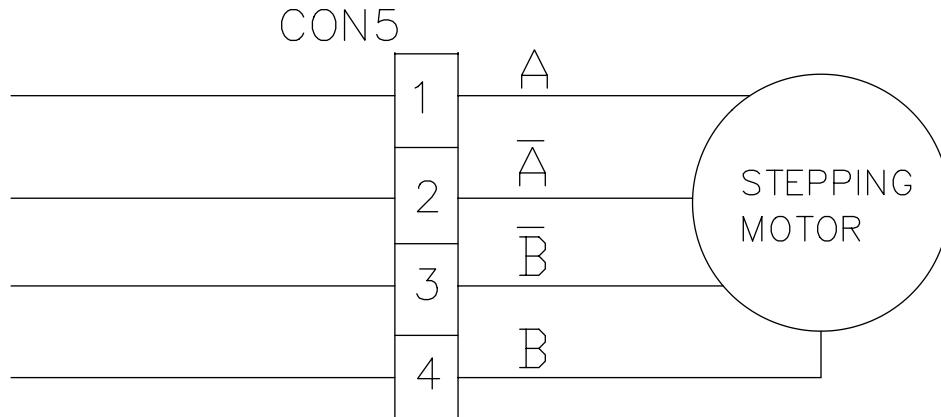

8-3 TROUBLESHOOTING

PROBLEM	INDICATED BY	CHECK	CHECKING METHOD	CAUSE	SOLUTION
POWER SOURCE is poor.	1. The whole DISPLAY LED/SEVEN SEGMENT DISPLAY is off.	1. FREEZER/ REFRIGERATOR.	Check if FREEZER/REFRIGERATOR DOOR IS OPEN and check display.	POWER SOURCE is poor.	Use boosting TRANS.
		2. If LAMP is dim.	Check visually.	Applied voltage error.	Reconnect CONNECTOR.
	2. DISPLAY LED/ SEVEN SEGMENT DISPLAY operates abnormally	3. The connection of the MAIN PWB CONNECTOR.	Check connection of CONNECTOR.	CONNECTOR connection is poor.	Replace TRANS.
				TRANS FUSE is open.	Replace COMPRESSOR.
COOLING is poor.	NO COOLING.	1. If the COMPRESSOR operate.	USE TEST MODE1 (forced COOLING). If less than 7 minutes pass after compressor shuts off, don't press the KEY and wait.	COMPRESSOR locked or blocked.	Replace OLP, PTC.
				OLP, PTC is poor. COMPRESSOR RELAY is poor.	Replace MAIN PWB.
				THE CONNECTING WIRE is poor.	Check the connection of the black wire of the MAIN PWB CONNECTOR (CON2).
		2. If refrigerant is leaking.	Measure the amount of frost sticking on EVAPORATOR and the surface temperature of the condenser pipe.	Refrigerant leakage.	Replace the leaking part and replace any lost refrigerant.
	FREEZER TEMPERATURE is incorrect	1. If FAN MOTOR operates.	USE TEST MODE1 (forced COOLING).	FAN MOTOR is poor.	Replace the FAN MOTOR.
				CONNECTING WIRE is poor.	Certify the MOTOR and the connection of the black wire of the MAIN PWB CONNECTOR (CON2).
		2. If DEFROSTING is normal.	Check the amount of frost sticking on the EVAPORATOR .	DEFROSTING is poor.	See DEFROSTING is poor.
		3. If SENSOR is normal.	of the Refrigerator SENSOR.	SENSOR RESISTANCE is poor.	Replace SENSOR.
		4. Door Line contact.	Check the seal when the door is closed.	Door liner damaged.	Replace door liner.

PROBLEM	INDICATED BY	CHECK	CHECKING METHOD	CAUSE	SOLUTION
COOLING is poor.	If REFRIGERATOR TEMPERATURE is too low.	1. If FREEZER TEMPERATURE is normal.	Check is FREEZER TEMPERATURE is too low.		Make sure the DOOR is attached.
		2. If amount of cool air from FAN MOTOR is sufficient.	Make sure that the amount and speed of cool air are sufficient by touching the check supplied on the REFRIGERATOR.	FAN MOTOR is poor.	Replace FAN MOTOR.
				Passage of cool air is blocked.	Remove impurities.
		3. Door Line contact.	Check door seal when door is closed.	EVA frozen.	See DEFROSTING is poor.
Door liner damaged.	Replace Door liner.				
DEFROSTING is poor.	NO DEFROSTING.	1. If HEATER emits heat.	USE TEST MODE3 (forced DEFROSTING).	HEATER disconnection.	Replace HEATER.
				TEMPERATURE FUSE disconnection.	Replace TEMPERATURE FUSE.
				Connection is poor.	Check EVAPORATOR connection and wire of MAIN PWB CONNECTOR.
				DEFROST-SENSOR is poor.	Replace DEFROST-SENSOR.
				HEATER RELAY is poor.	Replace RY3 of MAIN PWB.
		2. If DRAIN PIPE is blocked.	Check DRAIN PIPE.	DRAIN PIPE is blocked.	Remove ice and impurities.
					Check HEATER PLATE resistance.
		3. If ice remains after DEFROSTING.	Make sure that DEFROST SENSOR is connected.	Connection is poor.	Reassemble the DEFROST-SENSOR.
Make sure that FREEZER /REFRIGERATOR DOOR is closed.	DOOR does not close properly.				Reassemble DOOR. Replace GASKET.

8-4 MAIN PWB ASSEMBLY AND PARTS LIST

8-4-1 Main PWB Assembly

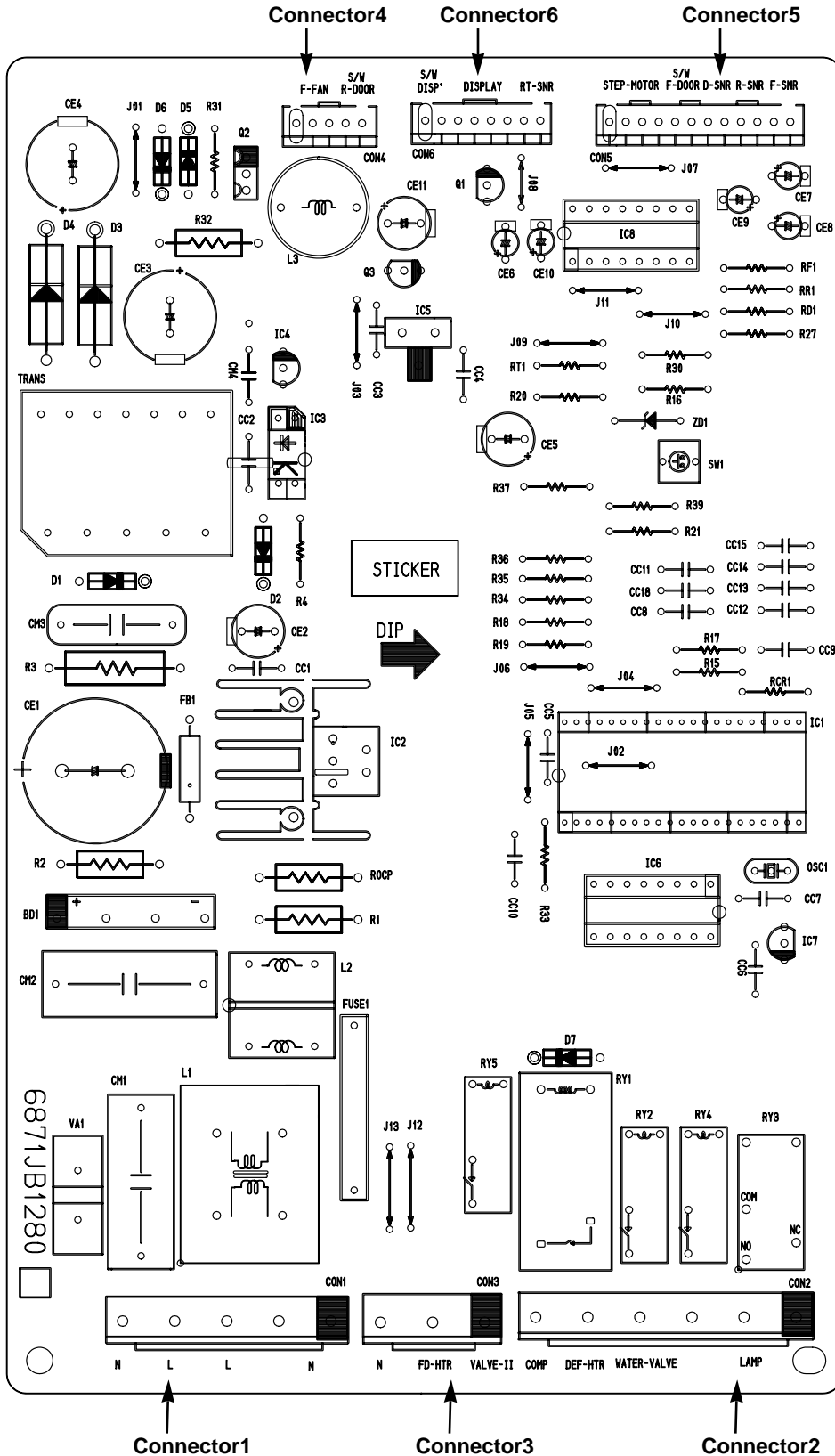

9. EXPLODED VIEW & REPLACEMENT PARTS LIST

CASE PARTS

CAUTION: Use the part number to order part, not the position number.

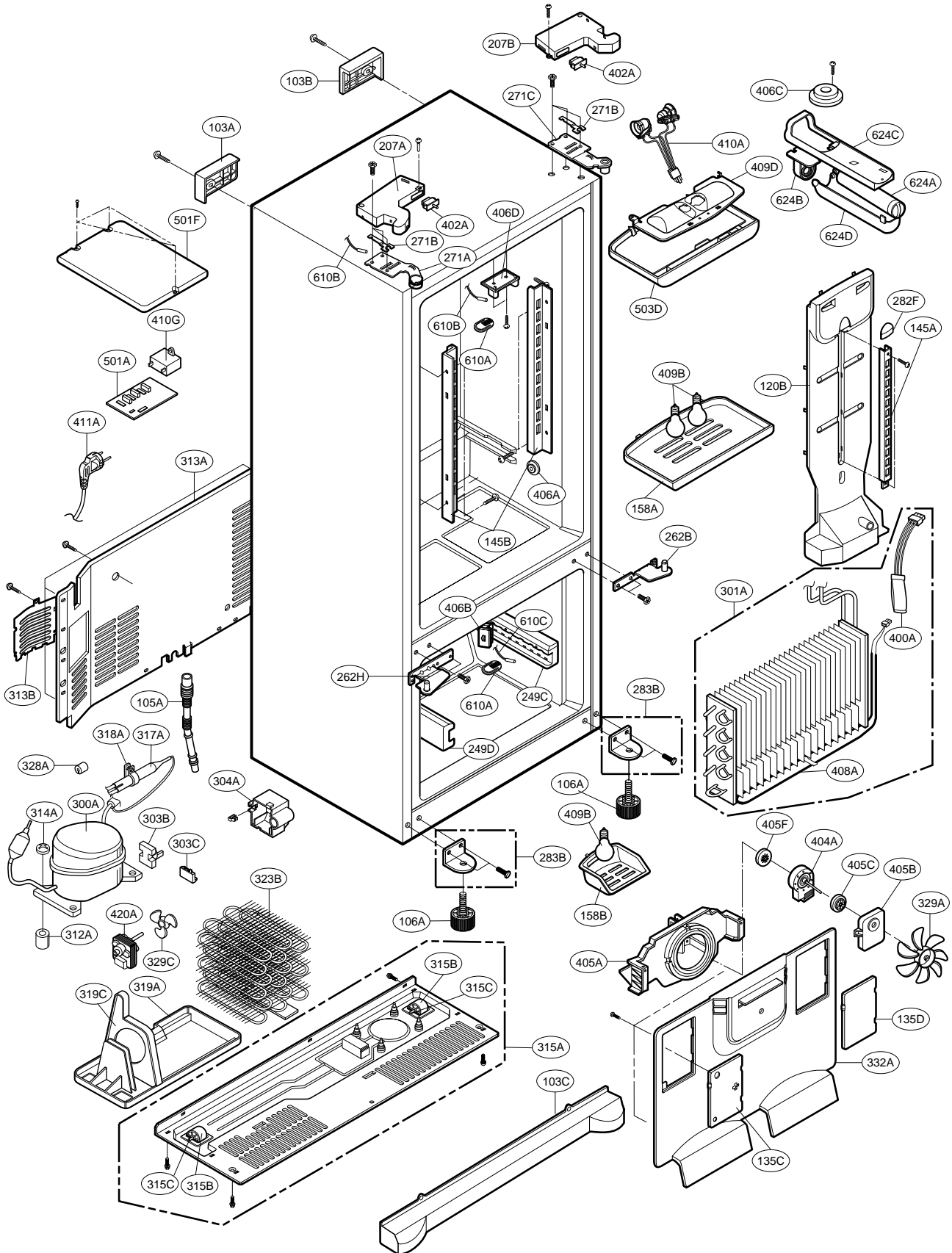

FREEZER PARTS

CAUTION: Use the part number to order part, not the position number.

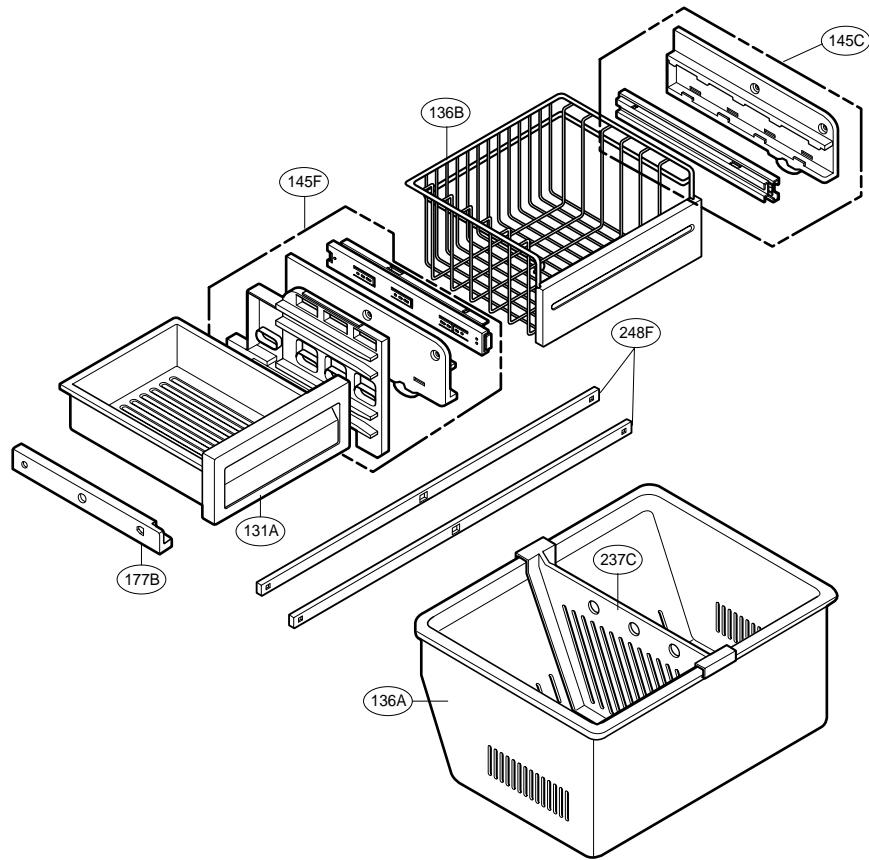

REFRIGERATOR PARTS

CAUTION: Use the part number to order part, not the position number.

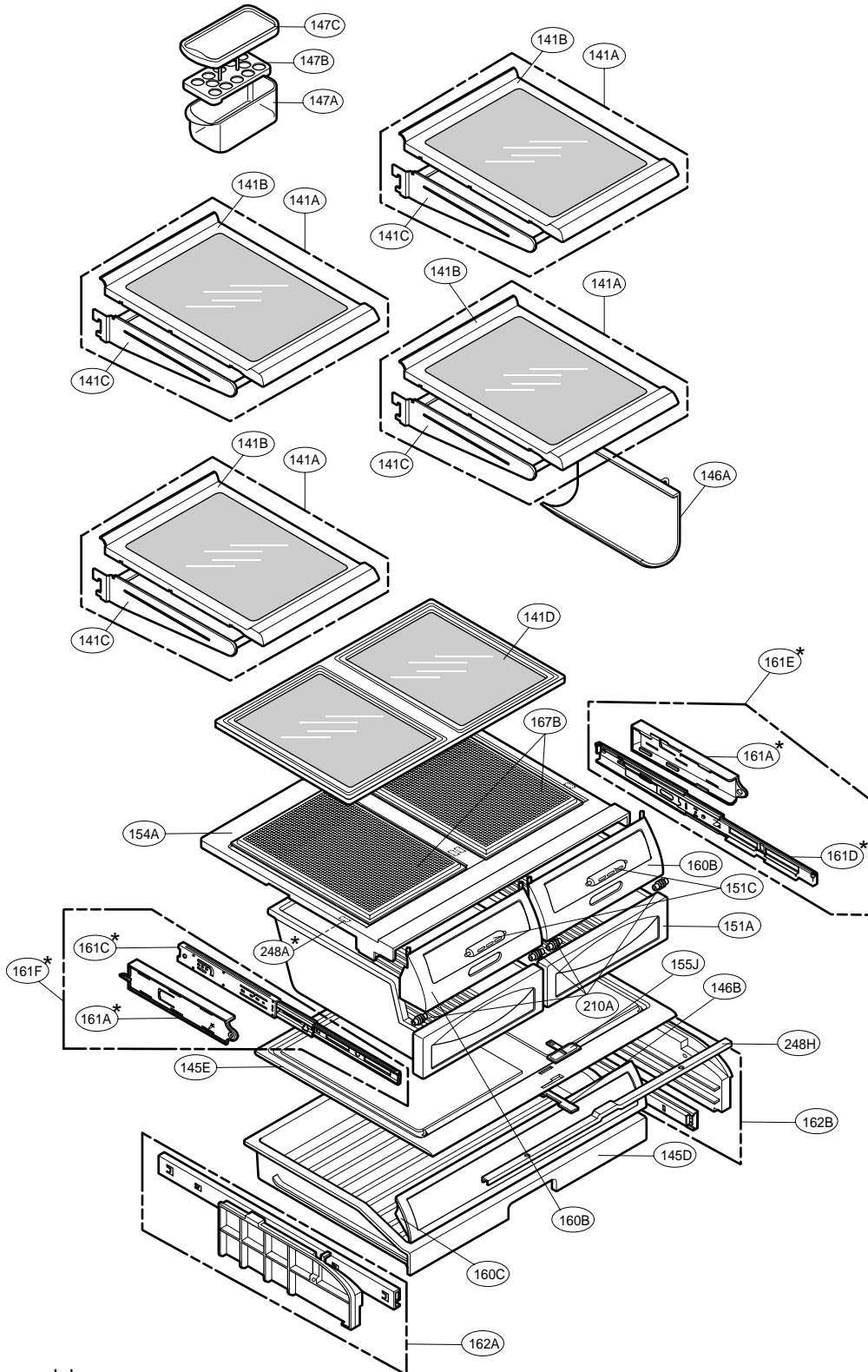

* : on some models

DOOR PARTS

CAUTION: Use the part number to order part, not the position number.

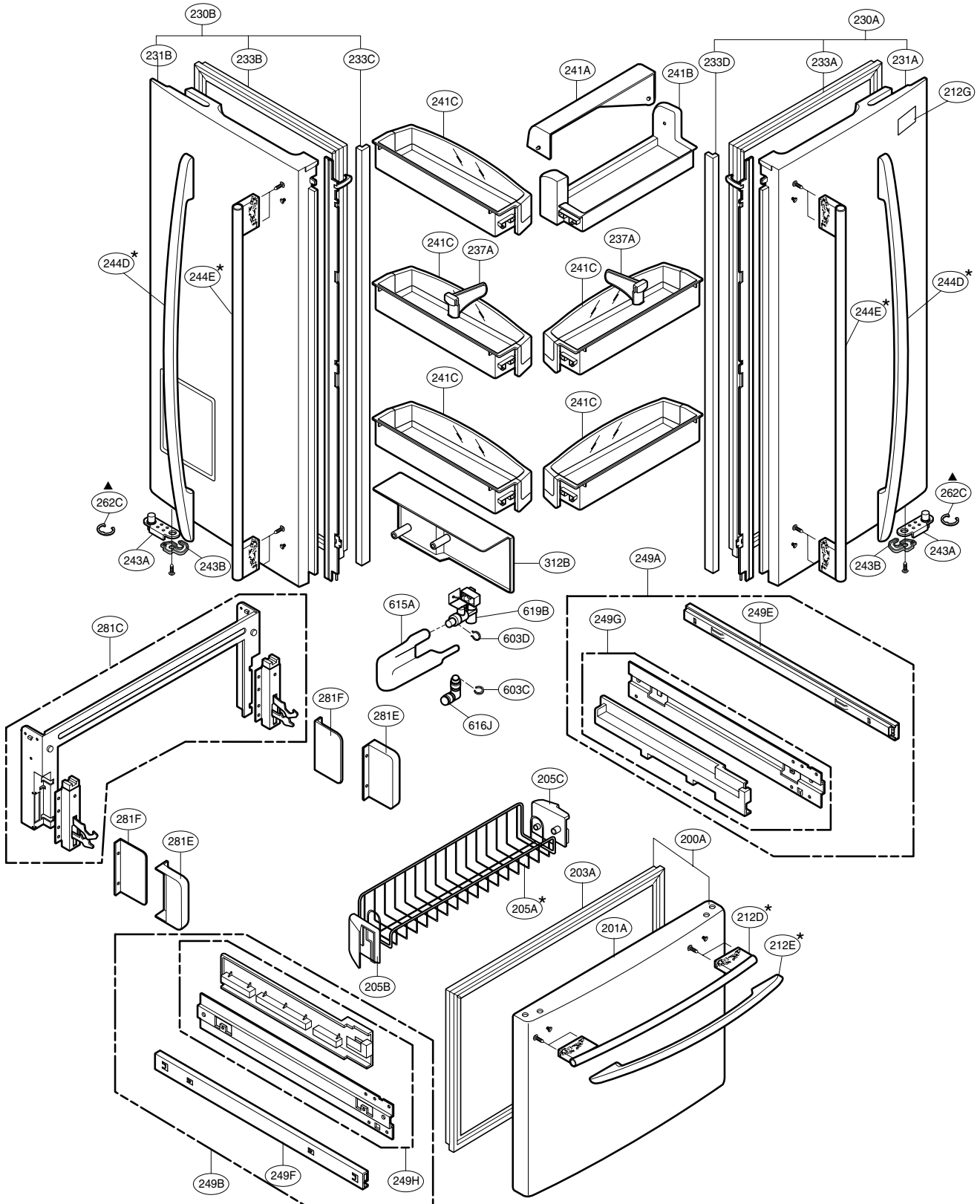

* : on some models
▲ only for the service

DISPENSER PARTS

CAUTION: Use the part number to order part, not the position number.

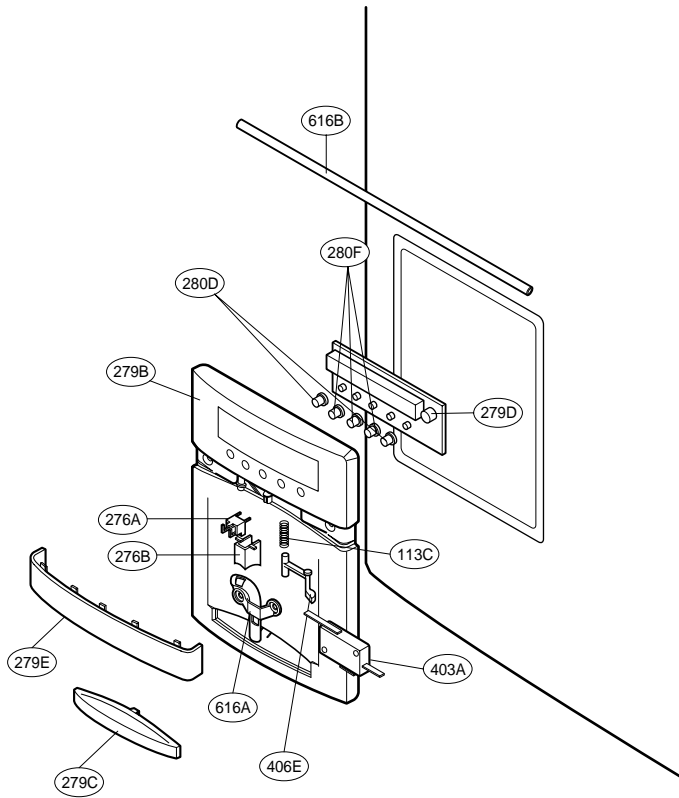

ICE & MAKER PARTS

CAUTION: Use the part number to order part, not the position number.

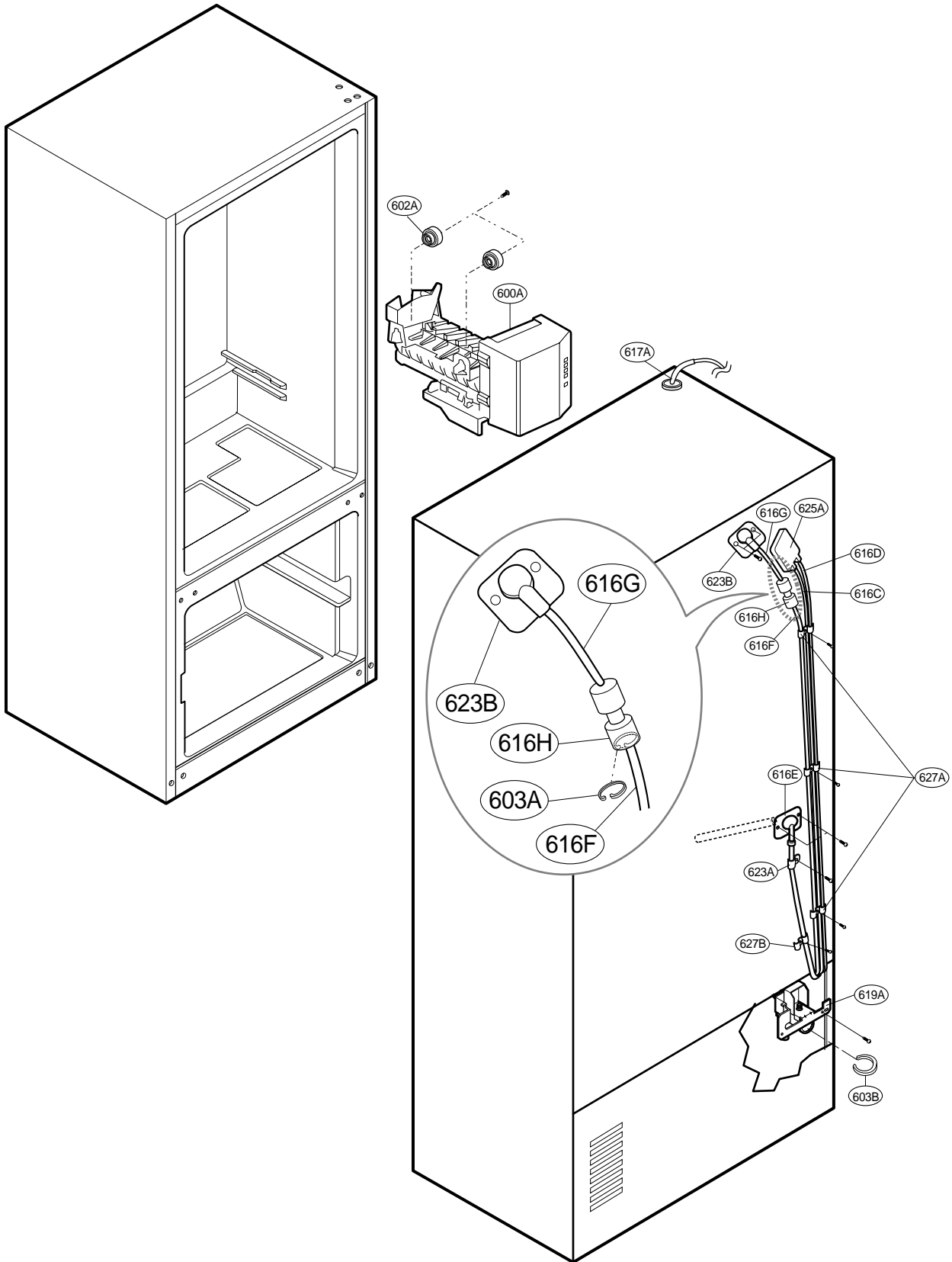



P/No. 3828JL8066B

FEB., 2005 Printed in Korea