



LG

<http://biz.lgservice.com>

REFRIGERATOR

SERVICE MANUAL

CAUTION
BEFORE SERVICING THE UNIT,
READ THE SAFETY PRECAUTIONS IN THIS MANUAL.

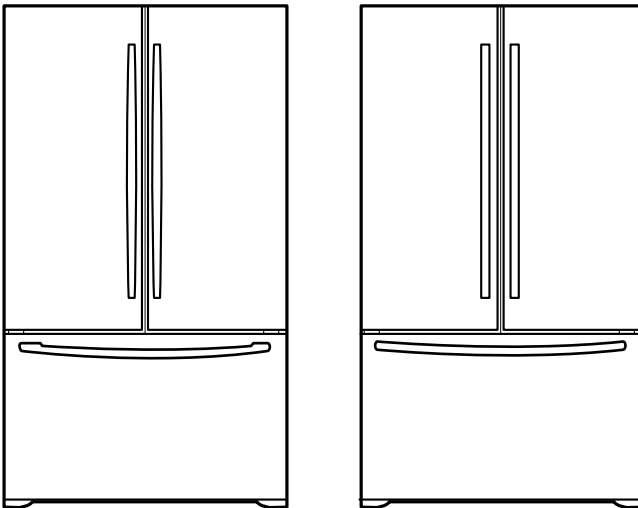

**MODEL:LRFC25750ST
LRFC21755SB
LRFC21755ST
LRFC21755TT**

**COLOR: WESTERN BLACK
STAINLESS-STEEL
TITANIUM**

CONTENTS

SAFETY PRECAUTIONS	2
SPECIFICATIONS	3
PARTS IDENTIFICATION	4
DISASSEMBLY	5-6
DOOR	5
FAN AND FAN MOTOR.....	6
DEFROST CONTROL ASSEMBLY	6
LAMP	6
CONTROL BOX-REFRIGERATOR	6
MULTI DUCT	6
ADJUSTMENT	7-8
COMPRESSOR.....	7
PTC-STARTER.....	7
OLP (OVERLOAD PROTECTOR).....	8
TO REMOVE THE COVER PTC	8
CIRCUIT DIAGRAM	9
TROUBLESHOOTING	10-15
COMPRESSOR AND ELECTRIC COMPONENTS	10
PTC AND OLP	11
OTHER ELECTRICAL COMPONENTS	12
SERVICE DIAGNOSIS CHART.....	13
REFRIGERATION CYCLE	14-15
OPERATION PRINCIPLE & REPAIR METHOD OF ICEMAKER	16-19
DESCRIPTION OF FUNCTION & CIRCUIT OF MICOM	20-38
EXPLODED VIEW & REPLACEMENT PARTS LIST	39-

SAFETY PRECAUTIONS

Please read the following instructions before servicing your refrigerator.

1. Check the refrigerator for current leakage.
2. To prevent electric shock, unplug before servicing.
3. Always check line voltage and amperage.
4. Use standard electrical components.
5. Don't touch metal products in the freezer with wet hands. This may cause frostbite.
6. Prevent water from spilling onto electric elements or the machine parts.
7. Close the top door before opening the bottom door. Otherwise, you might hit your head when you stand up.
8. When tilting the refrigerator, remove any materials on the refrigerator, especially the thin plates (ex. glass shelf or books.)
9. When servicing the evaporator, wear cotton gloves. This is to prevent injuries from the sharp evaporator fins.
10. Service on the refrigerator should be performed by a qualified technician. Sealed system repair must be performed by a CFC certified technician.

1. SPECIFICATIONS

21 cu. ft. / 25 cu. ft.

ITEMS	SPECIFICATIONS	ITEMS	SPECIFICATIONS	
DOOR DESIGN	Side Rounded	VEGETABLE TRAY	Opaque Drawer Type	
DIMENSIONS (inches)	35 3/4 x 30 x 69 3/4 (WxDxH) 21cu.ft	COMPRESSOR	PTC Starting Type	
	35 3/4 x 34 1/4 x 69 3/4 (WxDxH) 25cu.ft	EVAPORATOR	Fin Tube Type	
NET WEIGHT (pounds)	278 (21cu.ft)	CONDENSER	Wire Condenser	
	302 (25cu.ft)	REFRIGERANT	R-134a (115 g)	
COOLING SYSTEM	Fan Cooling	LUBRICATING OIL	Freol @ 10G (310 cc)	
TEMPERATURE CONTROL	Micom Control	DEFROSTING DEVICE	SHEATH HEATER	
DEFROSTING SYSTEM	Full Automatic	LAMP	REFRIGERATOR	60 W (2EA)
	Heater Defrost		FREEZER	40 W (1EA)
DOOR FINISH	Embossed Metal, VCM, Stainless			
HANDLE TYPE	Bar			
INNER CASE	ABS Resin			
INSULATION	Polyurethane Foam			

2. PARTS IDENTIFICATION

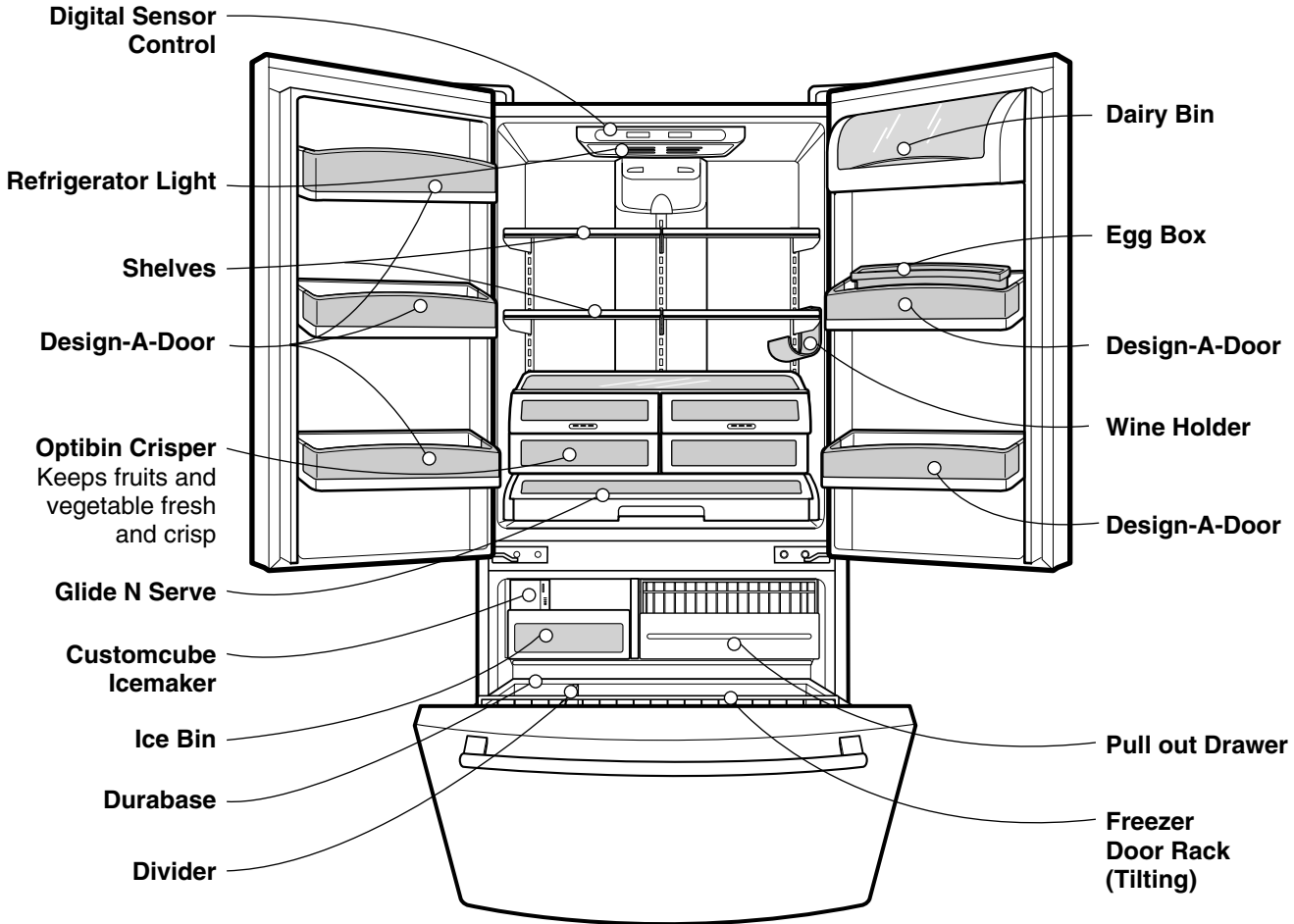

3. DISASSEMBLY

3-1 DOOR

● Refrigerator Door

1. Remove the hinge cover by pulling it upwards.
2. Loosen the hex head bolts attaching the upper hinge to the body and lift the freezer door.

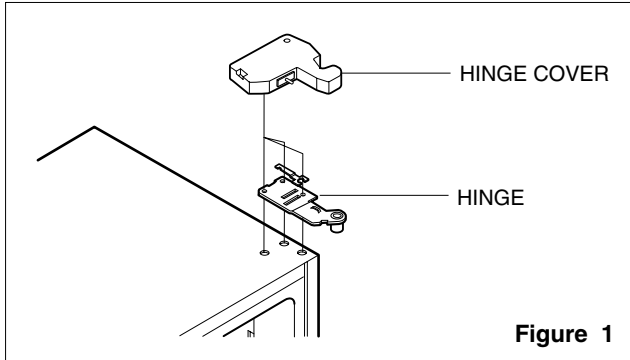

3. Pull out the door gasket to remove from the door foam assembly.

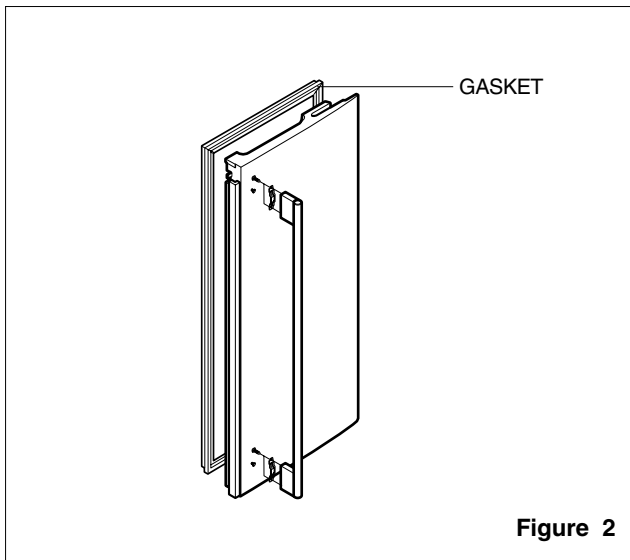

● Freezer Door

1. Loosen the hex head bolts attaching the lower hinge to the body to remove the refrigerator door only.

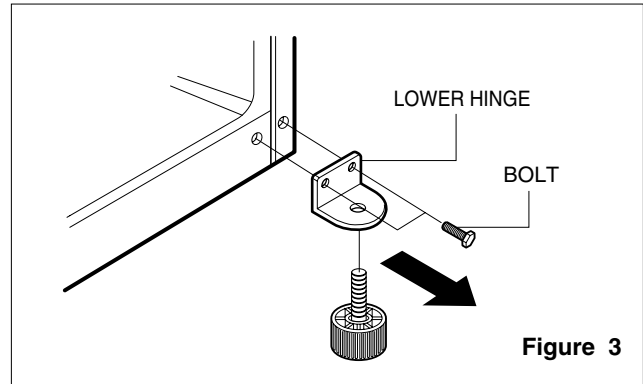

2. Pull out the door gasket to remove from the door foam assembly.

3-2 FAN AND FAN MOTOR

1. Remove the freezer shelf. (If your refrigerator has an icemaker, remove the icemaker first)
2. Remove the grille by pulling it out and by loosening a screw.
3. Remove the Fan Motor assembly by loosening 2 screws and disassemble the shroud.
4. Pull out the fan and separate the Fan Motor and Bracket.

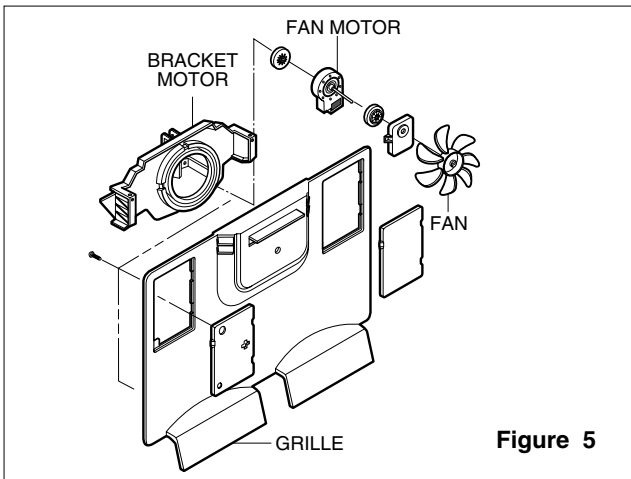

3-3 DEFROST CONTROL ASSEMBLY

Defrost Control assembly consists of Defrost Sensor and FUSE-M.

The Defrost Sensor works to defrost automatically. It is attached to the metal side of the Evaporator and senses its temperature. At 72°C, it turns the Defrost Heater off.

Fuse-M is a safety device for preventing over-heating of the Heater when defrosting.

1. Pull out the grille assembly. (Figure 6)
2. Separate the connector with the Defrost Control assembly and replace the Defrost Control assembly after cutting the Tie Wrap. (Figure 7)

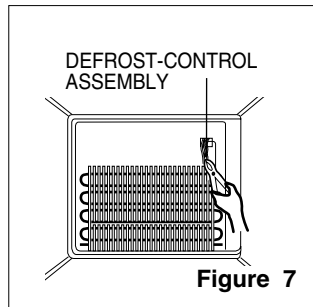
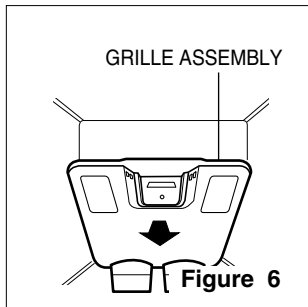

3-4 LAMP

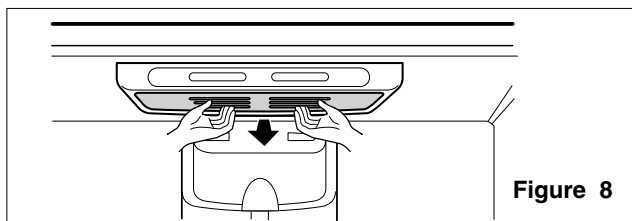

3-4-1 Refrigerator Compartment Lamp

1. Unplug the power cord from the outlet.
2. Remove refrigerator shelves.
3. Release the hooks on both ends of the lamp shield and pull the shield downward to remove it.
4. Turn the lamp counterclockwise.
5. Assemble in reverse order of disassembly. Replacement bulb must be the same specification as the original (Max. 60 W2EA).

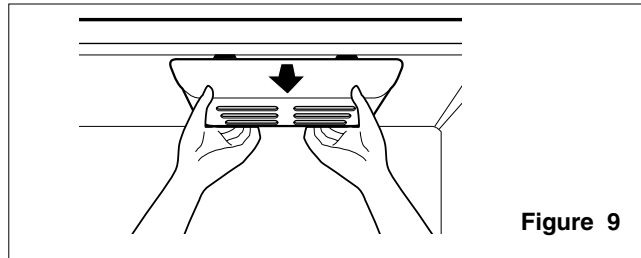

3-4-2 Freezer Compartment Lamp

1. Unplug refrigerator or disconnect power.
2. Reach behind light shield to remove bulb.
3. Replace bulb with a 40-watt appliance bulb.
4. Plug in refrigerator or reconnect power.

3-5 CONTROL BOX-REFRIGERATOR

1. First, remove all shelves in the refrigerator, then remove the Refrigerator control Box by loosening 2 screws.

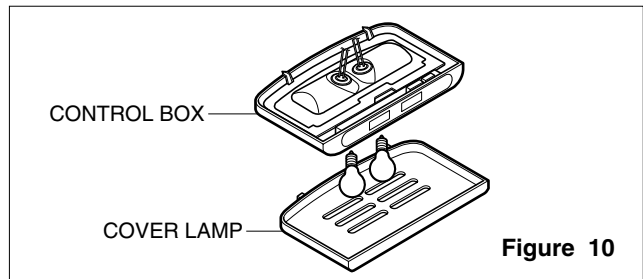

2. Remove the Refrigerator Control Box by pulling it downward.
3. Disconnect the lead wire on the right position and separate the lamp sockets.

3-6 MULTI DUCT

1. Remove an upper and lower Cap by using a flat screwdriver, and loosen 3 screws. (Figure 11)
2. Disconnect the lead wire on the bottom position.

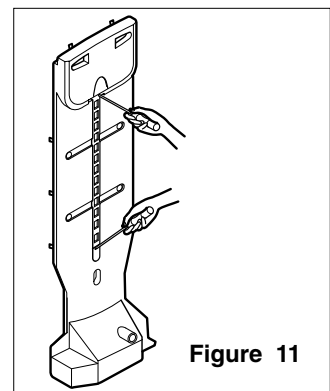

4. ADJUSTMENT

4-1 COMPRESSOR

4-1-1 Role

The compressor intakes low temperature and low pressure gas from the evaporator of the refrigerator and compresses this gas to high-temperature and high-pressure gas. It then delivers the gas to the condenser.

4-1-2 Composition

The compressor includes overload protection. The PTC starter and OLP (overload protector) are attached to the outside of the compressor. Since the compressor is manufactured to tolerances of 1 micron and is hermetically sealed in a dust and moisture-free environment, use extreme caution when repairing it.

4-1-3 Note for Usage

- (1) Be careful not to allow over-voltage and over-current.
- (2) If compressor is dropped or handled carelessly, poor operation and noise may result.
- (3) Use proper electric components appropriate to the Particular Compressor in your product.
- (4) Keep Compressor dry.
If the Compressor gets wet (in the rain or a damp environment) and rust forms in the pin of the Hermetic Terminal, poor operation and contact may result.
- (5) When replacing the Compressor, be careful that dust, humidity, and soldering flux don't contaminate the inside of the compressor. Dust, humidity, and solder flux contaminate the cylinder and may cause noise, improper operation or even cause it to lock up.

4-2 PTC-STARTER

4-2-1 Composition of PTC-Starter

- (1) PTC (Positive Temperature Coefficient) is a no-contact semiconductor starting device which uses ceramic material consisting of BaTiO₃.
- (2) The higher the temperature is, the higher the resistance value. These features are used as a starting device for the Motor.

4-2-2 Role of PTC-Starter

- (1) The PTC is attached to the Sealed Compressor and is used for starting the Motor.
- (2) The compressor is a single-phase induction motor. During the starting operation, the PTC allows current flow to both the start winding and main winding.

4-2-3 PTC-Applied Circuit Diagram

● Starting Method for the Motor

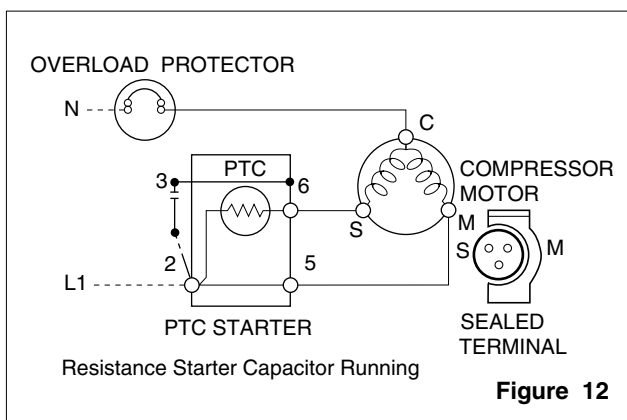

4-2-4 Motor Restarting and PTC Cooling

- (1) It requires approximately 5 minutes for the pressure to equalize before the compressor can restart.
- (2) The PTC device generates heat during operation. Therefore, it must be allowed to cool before the compressor can restart.

4-2-5 Relation of PTC-Starter and OLP

- (1) If the compressor attempts to restart before the PTC device is cooled, the PTC device will allow current to flow only to the main winding.
- (2) The OLP will open because of the over current condition. This same process will continue (3 to 5 times) when the compressor attempts to restart until the PTC device has cooled. The correct OLP must be properly attached to prevent damage to the compressor.

Parts may appear physically identical but could have different electrical ratings. Replace parts by part number and model number. Using an incorrect part could result in damage to the product, fire, injury, or possibly death.

4-2-6 Note for Using the PTC-Starter

- (1) Be careful not to allow over-voltage and over-current.
- (2) Do not drop or handle carelessly.
- (3) Keep away from any liquid.
If liquid such as oil or water enters the PTC, PTC materials may fail due to breakdown of their insulating capabilities.
- (4) If the exterior of the PTC is damaged, the resistance value may be altered. This can cause damage to the compressor and result in a no-start or hard-to-start condition.
- (5) Always use the PTC designed for the compressor and make sure it is properly attached to the compressor. Parts may appear physically identical but could have different electrical ratings. Replace parts by part number and model number. Using an incorrect part could result in damage to the product, fire, injury, or possibly death.

4-3 OLP (OVERLOAD PROTECTOR)

4-3-1 Definition of OLP

- (1) OLP (OVERLOAD PROTECTOR) is attached to the Compressor and protects the Motor by opening the circuit to the Motor if the temperature rises and activating the bimetal spring in the OLP.
- (2) When high current flows to the Compressor motor, the Bimetal works by heating the heater inside the OLP, and the OLP protects the Motor by cutting off the current flowing to the Compressor Motor.

4-3-2 Role of the OLP

- (1) The OLP is attached to the Sealed Compressor used for the Refrigerator. It prevents the Motor Coil from being started in the Compressor.
- (2) For normal operation of the OLP, do not turn the Adjust Screw of the OLP in any way.

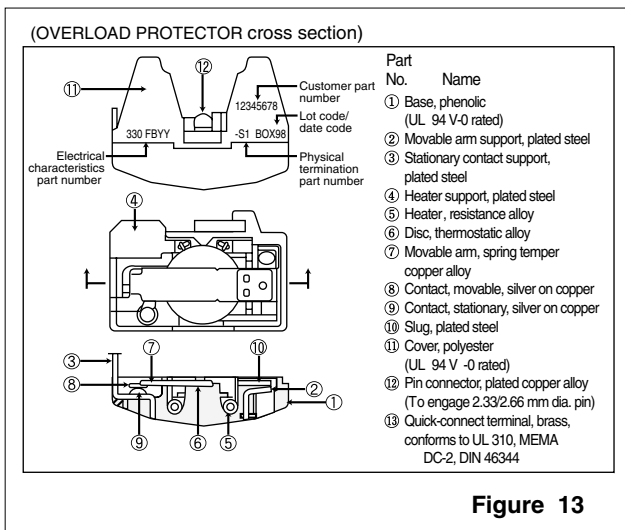
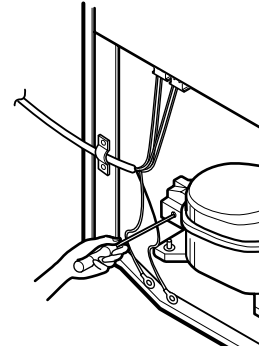
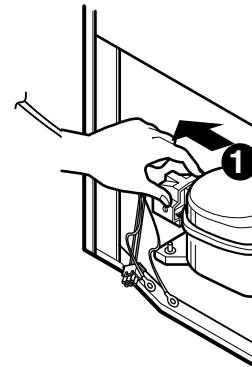

Figure 13

4-4 TO REMOVE THE COVER PTC



- 1) Remove the Cover Back M/C.
- (2) Remove the screw on Cover PTC.



- (3) Remove two Housings on upper part of Cover PTC.
- (4) Take out the cover PTC from upper to lower position like ①.

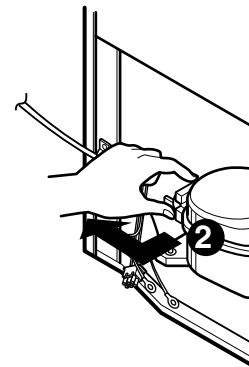

- (5) Turn 45° in the direction of ② and take it out.
- (6) Assembly in reverse order of disassembly.

5. CIRCUIT DIAGRAM

BETTER MODEL

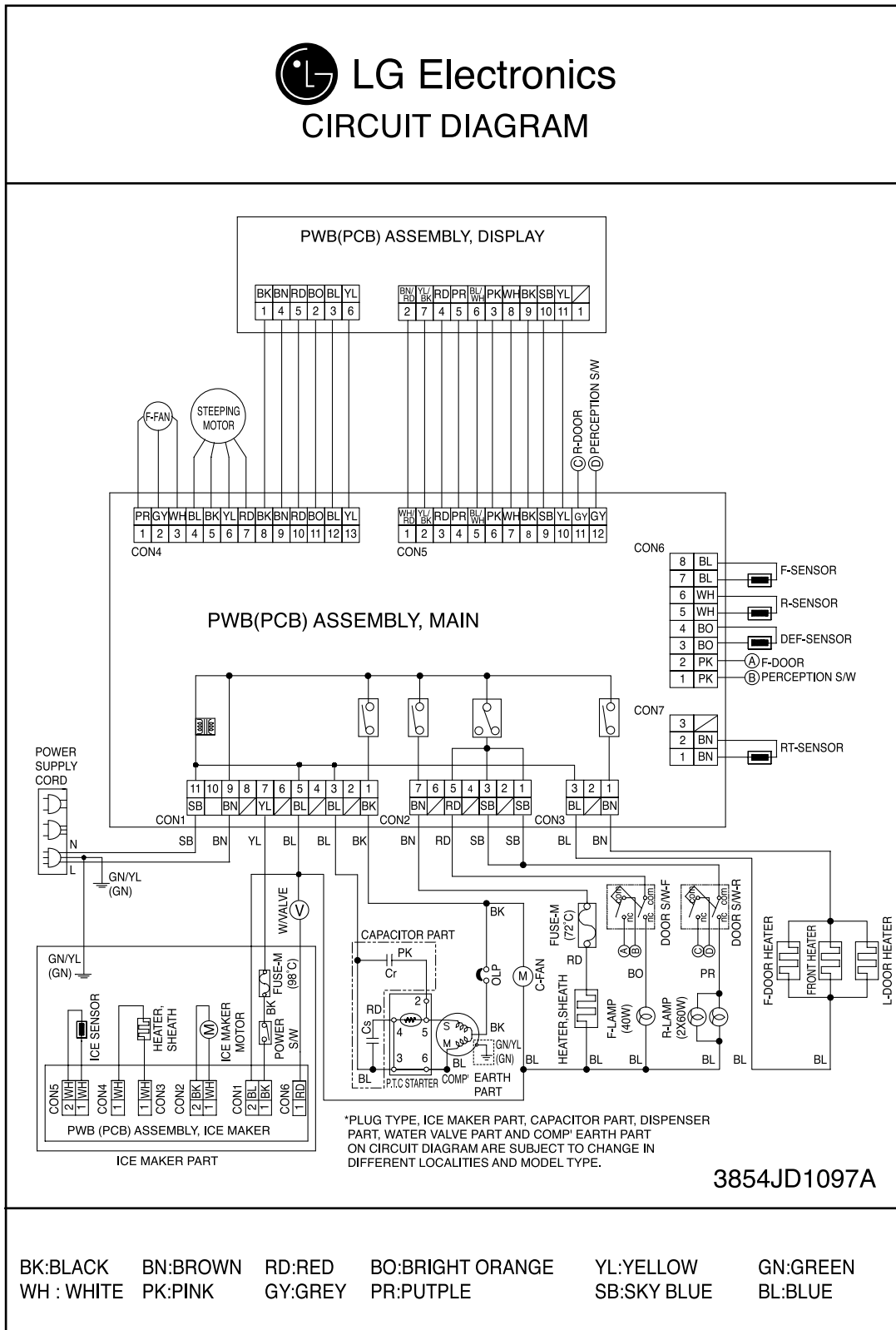

6. TROUBLESHOOTING

6-1 COMPRESSOR AND ELECTRIC COMPONENTS

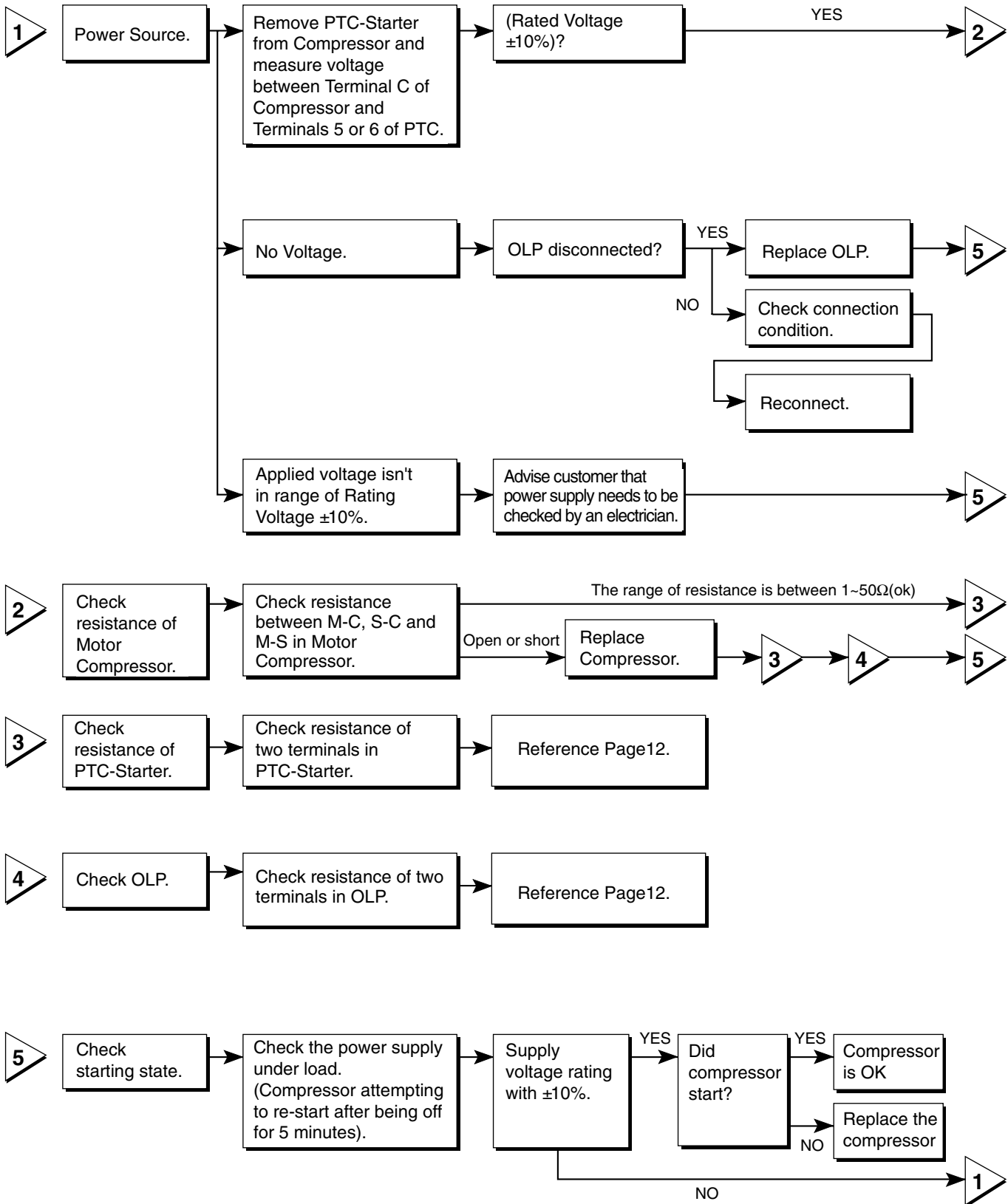

6-2 PTC AND OLP

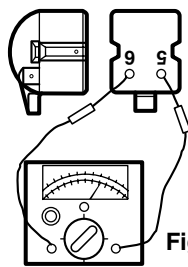
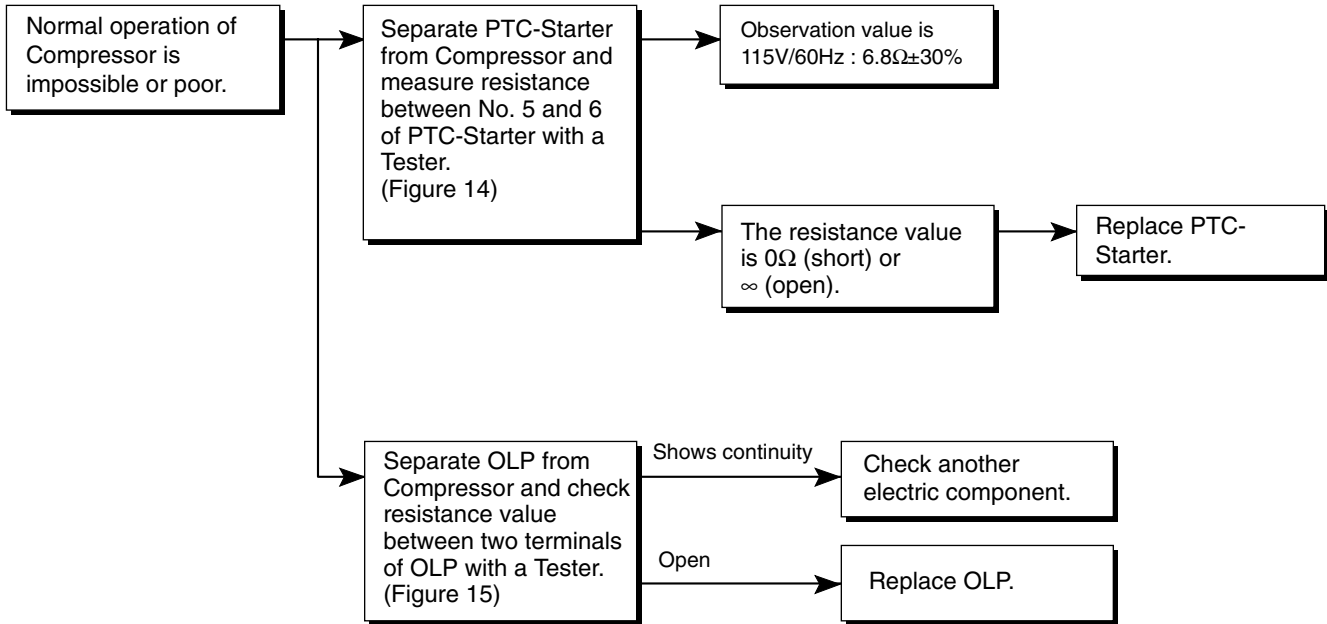

Figure 14

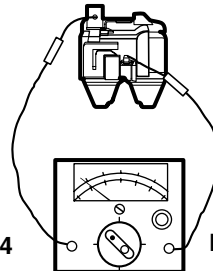
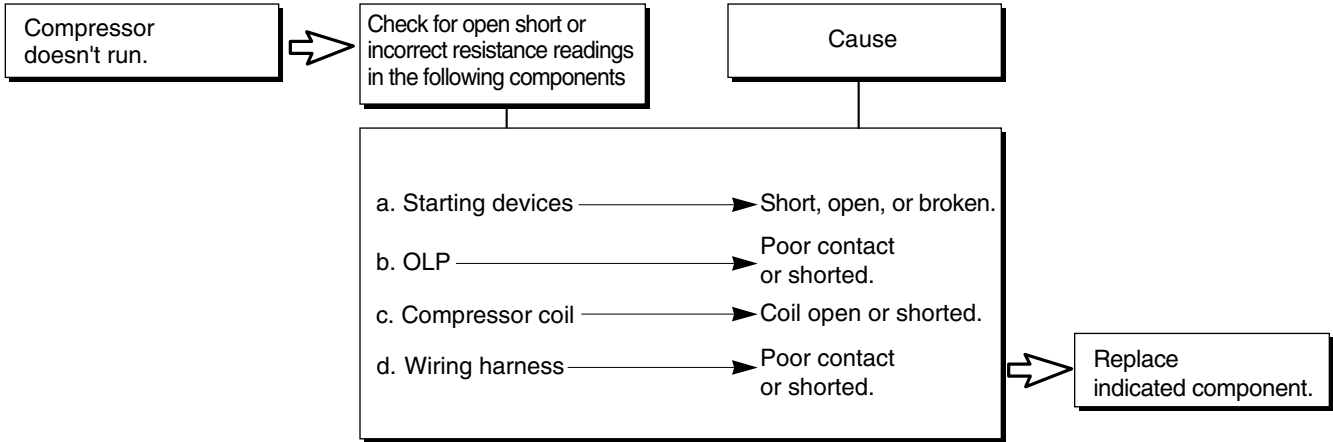

Figure 15

6-3 OTHER ELECTRICAL COMPONENTS

▼ Not cooling at all



▼ Poor cooling performance

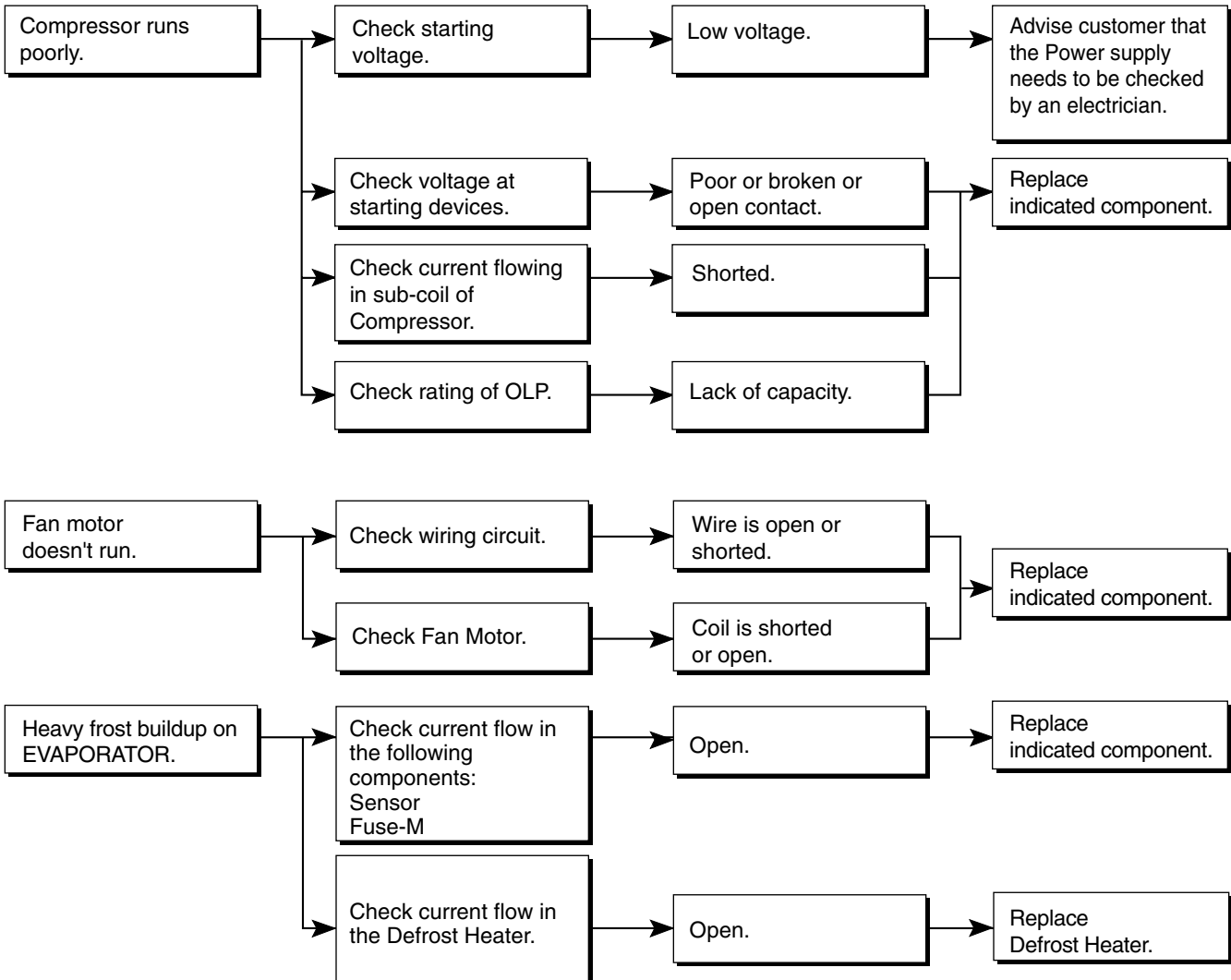

6-4 SERVICE DIAGNOSIS CHART

COMPLAINT	POINTS TO BE CHECKED	REMEDY
No Cooling.	<ul style="list-style-type: none"> • Is the power cord unplugged from the outlet? • Check if the power switch is set to OFF. • Check if the fuse of the power switch is shorted. • Measure the voltage of the power outlet. 	<ul style="list-style-type: none"> • Plug into the outlet. • Set the switch to ON. • Replace the fuse. • If the voltage is low, correct the wiring.
Cools poorly.	<ul style="list-style-type: none"> • Check if the unit is placed too close to the wall. • Check if the unit is placed too close to the stove, gas cooker, or in direct sunlight. • Is the ambient temperature too high or the room door closed? • Check if food put in the refrigerator is hot. • Did you open the door of the unit too often or check if the door is sealed properly? • Check if the Control is set to Warm position. 	<ul style="list-style-type: none"> • Place the unit about 4 inches (10 cm) from the wall. • Place the unit away from these heat sources. • Lower the ambient temperature. • Put in foods after they have cooled down. • Don't open the door too often and close it firmly. • Set the control to Recommended position.
Food in the Refrigerator is frozen.	<ul style="list-style-type: none"> • Is food placed in the cooling air outlet? • Check if the control is set to colder position. • Is the ambient temperature below 41°F(5°C)? 	<ul style="list-style-type: none"> • Place foods in the high-temperature section. (front part) • Set the control to Recommended position. • Set the control to Warm position.
Condensation or ice forms inside the unit.	<ul style="list-style-type: none"> • Is liquid food sealed? • Check if food put in the refrigerator is hot. • Did you open the door of the unit too often or check if the door is sealed properly? 	<ul style="list-style-type: none"> • Seal liquid foods with wrap. • Put in foods after they have cooled down. • Don't open the door too often and close it firmly.
Condensation forms in the Exterior Case.	<ul style="list-style-type: none"> • Check if the ambient temperature and humidity of the surrounding air are high. • Is there a gap in the door gasket? 	<ul style="list-style-type: none"> • Wipe moisture with a dry cloth. It will disappear in low temperature and humidity. • Fill up the gap.
There is abnormal noise.	<ul style="list-style-type: none"> • Is the unit positioned in a firm and even place? • Are any unnecessary objects placed in the back side of the unit? • Check if the Drip Tray is not firmly fixed. • Check if the cover of the compressor enclosure in the lower front side is taken out. 	<ul style="list-style-type: none"> • Adjust the Leveling Screw, and position the refrigerator in a firm place. • Remove the objects. • Fix the Drip Tray firmly in the original position. • Place the cover in its original position.
Door does not close well.	<ul style="list-style-type: none"> • Check if the door gasket is dirty with an item like juice. • Is the refrigerator level? • Is there too much food in the refrigerator? 	<ul style="list-style-type: none"> • Clean the door gasket. • Position in the firm place and level the Leveling Screw. • Make sure food stored in shelves does not prevent the door from closing.
Ice and foods smell unpleasant.	<ul style="list-style-type: none"> • Check if the inside of the unit is dirty. • Are foods with a strong odor unwrapped? • The unit smells of plastic. 	<ul style="list-style-type: none"> • Clean the inside of the unit. • Wrap foods that have a strong odor. • New products smell of plastic, but this will go away after 1-2 weeks.

● Other possible problems:

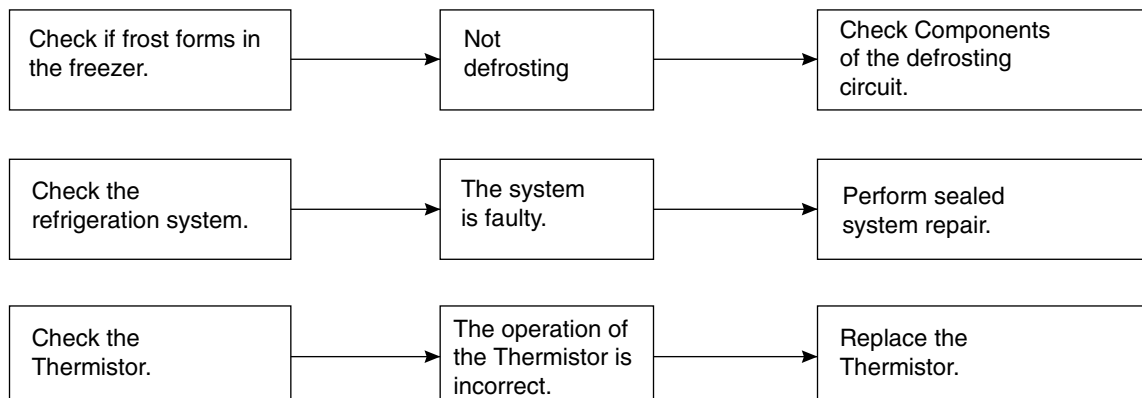

6-5 REFRIGERATION CYCLE

▼ Troubleshooting Chart

CAUSE		STATE OF THE UNIT	STATE OF THE EVAPORATOR	TEMPERATURE OF THE COMPRESSOR	REMARKS
LEAKAGE	PARTIAL LEAKAGE	Freezer compartment and Refrigerator don't cool normally.	Low flowing sound of Refrigerant is heard and frost forms in inlet only.	A little higher than ambient temperature.	<ul style="list-style-type: none"> Refrigerant level is low due to a leak. Normal cooling is possible by restoring the normal amount of refrigerant and repairing the leak.
	COMPLETE LEAKAGE	Freezer compartment and Refrigerator don't cool normally.	Flowing sound of refrigerant is not heard and frost isn't formed.	Equal to ambient temperature.	<ul style="list-style-type: none"> No discharging of Refrigerant. Normal cooling is possible by restoring the normal amount of refrigerant and repairing the leak.
CLOGGED BY DUST	PARTIAL CLOG	Freezer compartment and Refrigerator don't cool normally.	Flowing sound of refrigerant is heard and frost forms in inlet only.	A little higher than ambient temperature.	<ul style="list-style-type: none"> Normal discharging of the refrigerant. The capillary tube is faulty.
	WHOLE CLOG	Freezer compartment and Refrigerator don't cool.	Flowing sound of refrigerant is not heard and frost isn't formed.	Equal to ambient temperature.	<ul style="list-style-type: none"> Normal discharging of the Refrigerant.
MOISTURE CLOG		Cooling operation stops periodically.	Flowing sound of refrigerant is not heard and frost melts.	Lower than ambient temperature.	<ul style="list-style-type: none"> Cooling operation restarts when heating the inlet of the capillary tube.
DEFECTIVE COMPRESSION	COMP-RESSION	Freezer and Refrigerator don't cool.	Low flowing sound of refrigerant is heard and frost forms in inlet only.	A little higher than ambient temperature.	<ul style="list-style-type: none"> Low pressure at high side of compressor due to low refrigerant level.
	NO COMP-RESSION	No compressing operation.	Flowing sound of refrigerant is not heard and there is no frost.	Equal to ambient temperature.	<ul style="list-style-type: none"> No pressure in the high pressure part of the compressor.

6-5-1 SEALED SYSTEM DIAGNOSIS

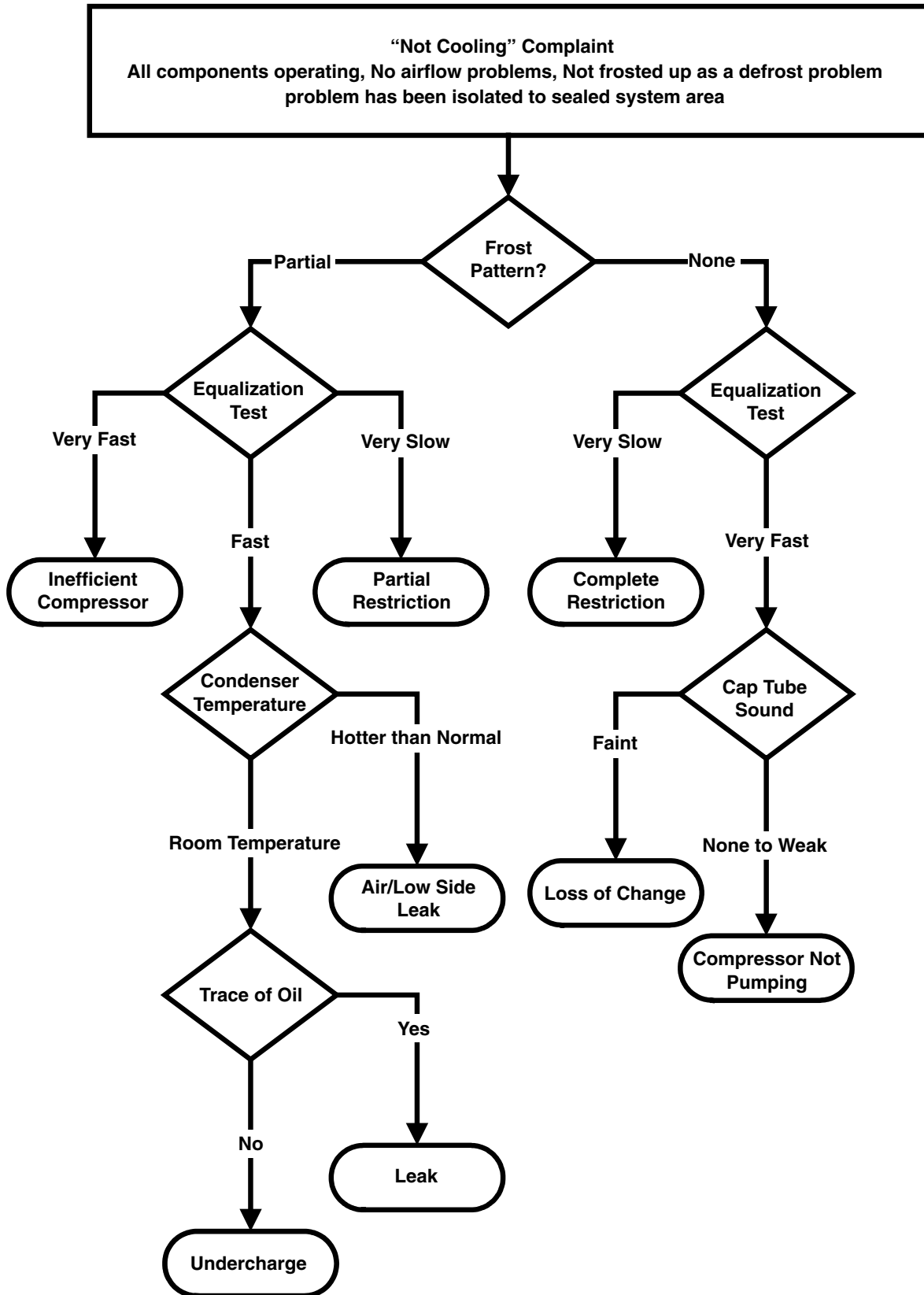

(The equalization test is trying to restart a compressor using a start kit after it has been operating.)

7. OPERATION PRINCIPLE AND REPAIR METHOD OF ICEMAKER

7-1 OPERATION PRINCIPLE

7-1-1 Operation Principle of IceMaker

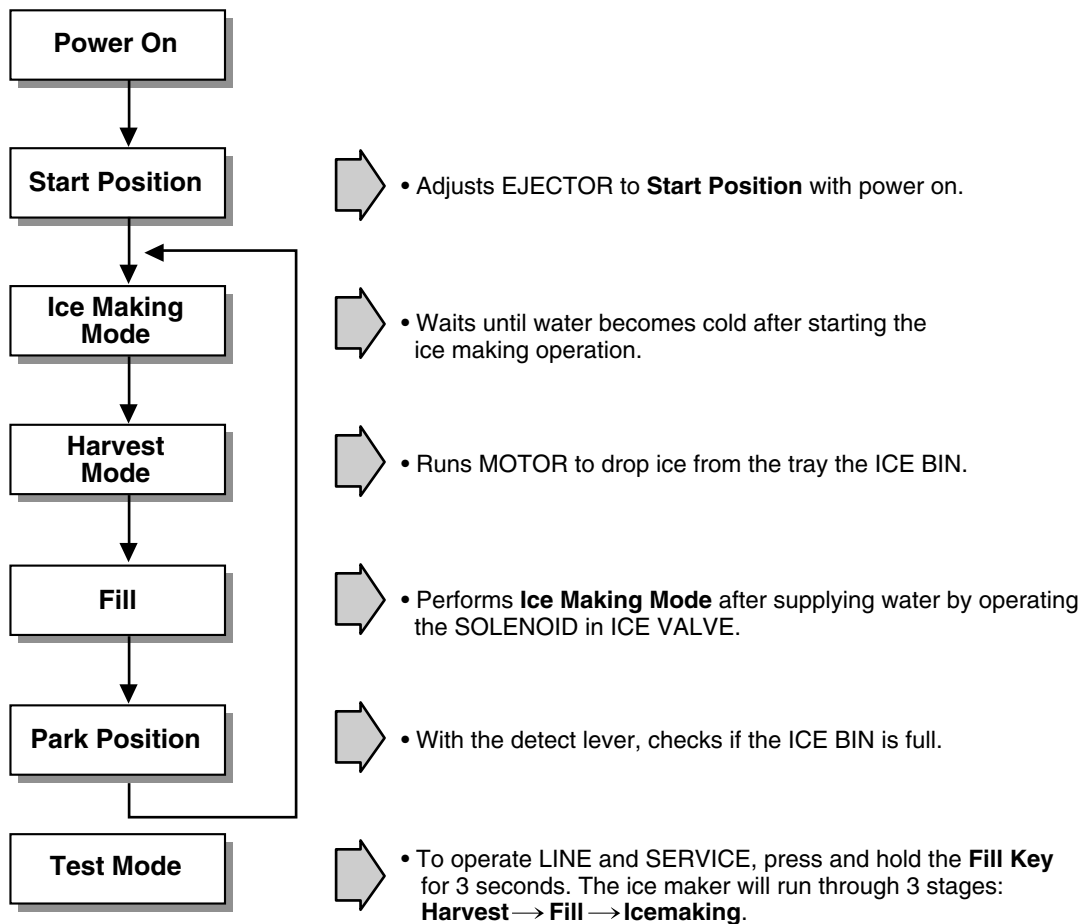

1. Turning the Icemaker stop switch off (O) stops the ice making function.
2. Setting the Icemaker switch to OFF and then turning it back on will reset the icemaker control.

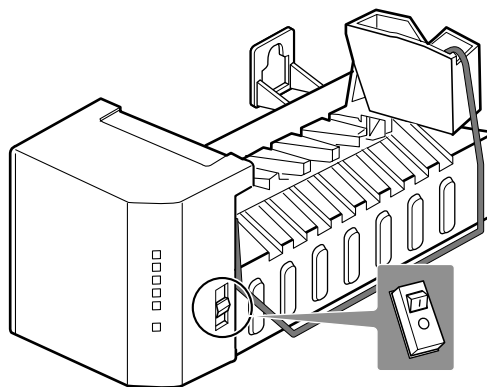

7-2 CONTROL METHOD ACCORDING TO FUNCTIONS

7-2-1 Start Position

1. After POWER OFF or Power Outage, check the EJECTOR's position with MICOM initialization to restart.
2. How to check if it is in place:
 - Check **HIGH/LOW** signals from HALL SENSOR in MICOM PIN.
3. Control Method to check if it is in place:
 - (1) EJECTOR is in place,
 - It is an initialized control, so the mode can be changed to ice making control.
 - (2) EJECTOR isn't in place:
 - A. If EJECTOR is back in place within 2 minutes with the motor on, it is being initialized. If not, go to Step B.
 - B. If EJECTOR is back in place within 18 minutes with the heater on (to control Heater on its OFF condition), it is being initialized. If not, it is not functioning. Repeat Step B with Heater and Motor off.

7-2-2 Ice Making Mode

1. Ice Making control refers to the freezing of supplied water in the ice trays. Complete ice making operations by measuring the temperature of the Tray with Ice-Making SENSOR.
2. Ice Making starts after completing fulfilled ice control and initial control.
3. The Ice Making function is completed when the sensor reaches 19°F(-7°C), 60 to 240 minutes after starting.
4. If the temperature sensor is defective, the ice-making function will be completed in 4 hours.

NOTE : After Icemaker Power is ON, the Icemaker heater will be on for test for 9 sec.

7-2-3 Harvest Mode

1. Ice-removing control refers to the operation of dropping cubes into the ice bin from the tray when ice-making has completed.
2. Ice removing control mode:
 - (1) Operates Heater for 30 seconds; then operate MOTOR.
 - (2) After performing Step 1 (to control the Heater on its off condition), Ice-Removal control will be back in place within 18 minutes. (Hall SENSOR sign = OV). Ice removal is then complete. Then change the mode to the water supply control. If this control phase fails to start, it is not functioning. Put the Heater and Motor in the off position. Restart every 2 hours. (Refer to fig.1)



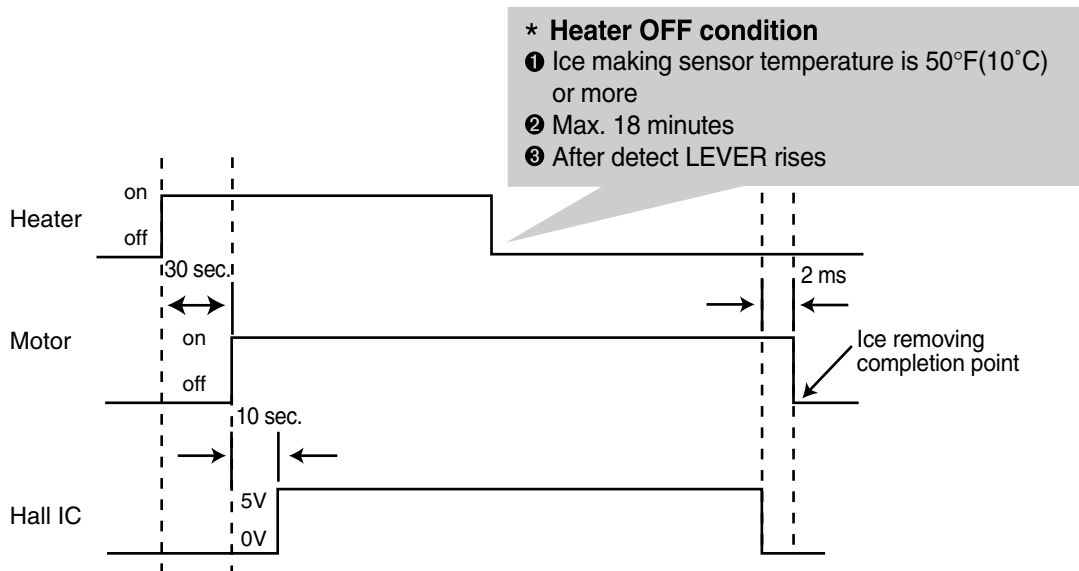

NOTE : If the motor malfunctions and starts before the detect lever rises, MICOM regards the Ice-Removing phase as completed. Water then starts flowing. To prevent this, MICOM doesn't switch to water-supply mode, but restarts the ice-removing mode. If this happens 3 times, the motor is malfunctioning and you should stop the loads (Heater, Motor). Then restart the Ice-Removing mode every 2 hours. (See Step 2 above.)



7-2-4 Fill / Park Position

1. Once a normal harvest mode has been completed, the water solenoid will be activated.
2. The amount of water is adjusted by pressing the water supply control S/W. This changes the time allowed for fill as illustrated in the chart.

<Water supply amount TABLE>

STAGE	TIME TO SUPPLY	INDICATIONS	REMARKS
1	6 sec.		The water amount will vary depending on the water control Switch setting, as well as the water pressure of the connected water line.
2	6.5 sec.		
3	7 sec.		
4	7.5 sec.		
5	8 sec.		



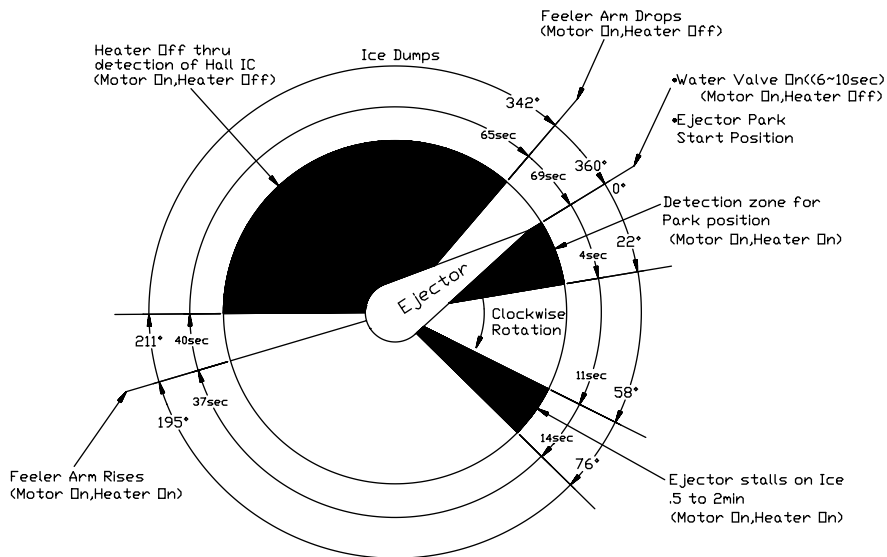

NOTE : Below is an example used by another vendor as an explanation of what is taking place.



7-2-5 Function TEST



1. This is a compulsory operation for TEST, SVC, cleaning, etc. It is operated by pressing the water supply control KEY for 3 seconds.
2. It operates in the Ice Making mode, but not in the Ice-Removing mode or water supply process. (If there is an ERROR, it can only be checked in the TEST mode.)
3. If the water supply control KEY is pressed for 3 seconds in the Ice-Making mode (no matter what condition the Ice-Making tray is in) the Ice-Removing operation starts immediately. Water is not yet frozen, so water is poured instead of ice. If the control doesn't operate normally in the TEST mode, check and repair as needed.
4. After water is supplied, the normal CYCLE is followed: **ice making** → **Harvest** → **Fill** → **Park Position**.
5. When Stage 5 is completed in the TEST mode, minimize MICOM in 5 seconds, the time needed to supply water resets to the previous status in the TEST mode.

<Diagnosis TABLE>

STAGE	ITEMS	INDICATOR	REMARKS
1	HEATER		Five seconds after heater starts, heater will go off if temperature recorded by sensor is 10°C or lever is in up position.
2	MOTOR		Five seconds after heater starts, you can confirm that motor is moving.
3	HALL IC I (detection of position)		You can confirm Hall Ic detection of position.
4	VALVE		Two seconds after detection of initial position, you can confirm that valve is on.
5	HALL IC II (detection of full-filled Ice)		You can check whether hall is sensing Full ice condition. (If there is a full-filled error, the fifth LED is not on.)
6	Reset	Mark Previous Status on TEST MODE	Five seconds after fifth stage is completed, the icemaker reset at initial status.

7-3 DEFECT DIAGNOSIS FUNCTION

7-3-1 ERROR CODES shown on Ice Maker water supply control panel

NO	DIVISION	INDICATOR	CONTENTS	REMARKS
1	Normal	Mark time to supply	None	Display switch operates properly
2	Ice-Making Sensor malfunction		Open or short-circuited wire	Make sure that the wire on each sensor is connected.
3	Ice Maker Kit malfunction		When ejector blades don't reach park position over 18 minutes since Harvest Mode starts.	Check of HALL IC/MOTOR/HEATER/RELAY

ERROR indicators in table can be checked only in TEST mode.

8. DESCRIPTION OF FUNCTION & CIRCUIT OF MICOM

8-1 FUNCTION

8-1-1 Function

1. When the appliance is plugged in, it is set to "37" for Refrigerator and "0" for freezer.
You can adjust the Refrigerator and the Freezer control temperature by pressing the ADJUST button.
2. When the power is initially applied or restored after a power failure, it is automatically set to "37" & "0".

Better Model

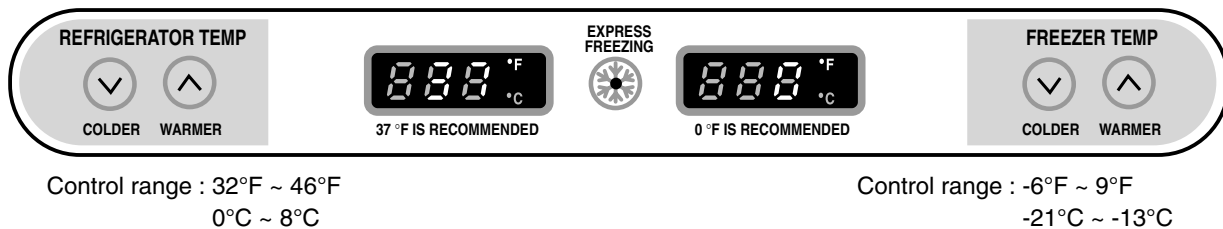

8-1-2 How to Change the Temperature Display from °F / °C

1. The temperature display can be toggled between °F & °C by pressing the Refrigerator COLDER key and the Freezer COLDER Key at the same time and holding for more than one second.
2. The initial setting is °F. Whenever the mode is changed, the LED lights are changed.

8-1-3 Control of freezer fan motor

1. Freezer fan motor has high and standard RPMs.
2. High RPM is used when electricity is first on, for express freezing, and when refrigerator is overloaded.
Standard RPM is used for normal usage.
3. Fan motor stops when refrigerator or freezer door opens.

8-1-4 EXPRESS FREEZING

1. The purpose of this function is to intensify the cooling speed of freezer and to increase the amount of ice.
2. Whenever selection switch is pressed, selection/release, the LED will turn ON or OFF.
3. If there is a power cut and the refrigerator is power on again, EXPRESS FREEZING function will be canceled.
4. To activate this function you need to press the Express Freezing key and the LED will turn ON. This function will remain activated for 24 hrs. The first three hours the compressor and Freezer Fan will be ON. The next 21 hours the freezer will be controlled at the lowest temperature. After 24 hours or if the Express Freezing key is pressed again, the freezer will return to its previous temperature.
5. For the first three hours notice the following cases:
 - (1) Compressor and freezer fan(HIGH RPM) continuously operate for three hours.
 - (2) If defrost starts during EXPRESS FREEZING, EXPRESS FREEZING operates for the rest of time after defrost is completed, when EXPRESS FREEZING operation time is less than 90 minutes.
If EXPRESS FREEZING operates for more than 90 minutes, the EXPRESS FREEZING will operate for two hours after defrost is completed.
 - (3) If EXPRESS FREEZING is pressed during defrost, EXPRESS FREEZING LED is on but this function will start seven minutes after defrost is completed and it shall operate for three hours.
 - (4) If EXPRESS FREEZING is selected within seven minutes after compressor has stopped, the compressor (compressor delays seven minutes) shall start after the balance of the delay time.
 - (5) The fan motor in the freezer compartment rotates at high speed during EXPRESS FREEZING.
6. For the rest of 21 hours, the freezer will be controlled at the lowest temperature.

8-1-5. REFRIGERATOR LAMP AUTO OFF

1. To protect the risk of lamp heat, when Refrigerator door opens for 7 min., refrigerator lamp is auto off.

8-1-6 Alarm for Open Door

1. This feature sounds a buzzer when the freezer or refrigerator door is not closed within 1 minute after it is opened.
2. One minute after the door is opened, the buzzer sounds three times each for 1/2 seconds. These tones repeat every 30 seconds.
3. The alarm is cancelled when the freezer or the refrigerator is closed while the buzzer sounds.

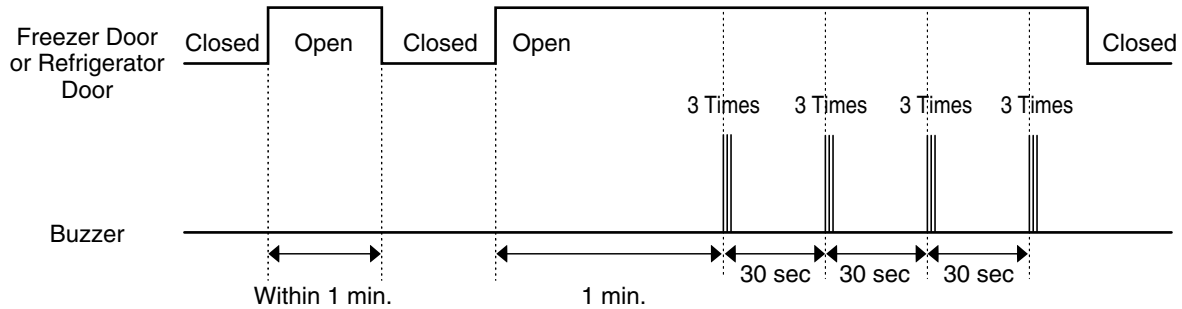

8-1-7 Buzzer Sound

When the button on the front Display is pushed, a Ding~ Dong~ sound is produced.

(Refer to the Buzzer Circuit 7-2-4 No. 2)

8-1-8 Defrosting (removing frost)

1. Defrosting starts each time the COMPRESSOR running time reaches 7 hours.
2. For initial power on or for restoring power, defrosting starts when the compressor running time reaches 4 hours.
3. Defrosting stops if the sensor temperature reaches 46.4°F(8°C) or more. If the sensor doesn't reach 46.4°F(8°C) in 2 hours, the defrost mode is malfunctioning. (Refer to the defect diagnosis function, 7-1-9.)
4. Defrosting won't function if its sensor is defective (wires are cut or short circuited)

8-1-9 Electrical Parts Are Turned On Sequentially

Electrical parts such as COMP, defrosting heater, freezer FAN, etc. are turned on in the following order to prevent noise and parts damage. Several parts are started at the same time at initial power on and are turned off together when TEST is completed.

OPERATING		ORDERS				
Initial power on	Temperature of Defrosting Sensor is 113°F [45°C] or more (when unit is newly purchased or when moved)	POWER ON	in 0.5 sec →	COMP ON	in 0.5 sec →	Freezer FAN ON
	Temperature of defrosting sensor is lower than 113°F [45°C] (when power cuts, SERVICE)	POWER ON	in 0.5 sec →	Defrosting heater ON	in 10 sec →	Defrost heater OFF
		in 0.5 sec →	COMP ON	in 0.5 sec →	Freezer FAN ON	
Reset to normal operation from TEST MODE		Total load OFF	in 7 min →	COMP ON	in 0.5 sec →	Freezer FAN ON

8-1-10 Defect Diagnosis Function

1. Automatic diagnosis makes servicing the refrigerator easy.
2. When a defect occurs, the buttons will not operate; but the tones, such as ding, will sound.
3. When the defect CODE removes the sign, it returns to normal operation (RESET).
4. The defect CODE shows on the Refrigerator and Freezer Display.

Better Model

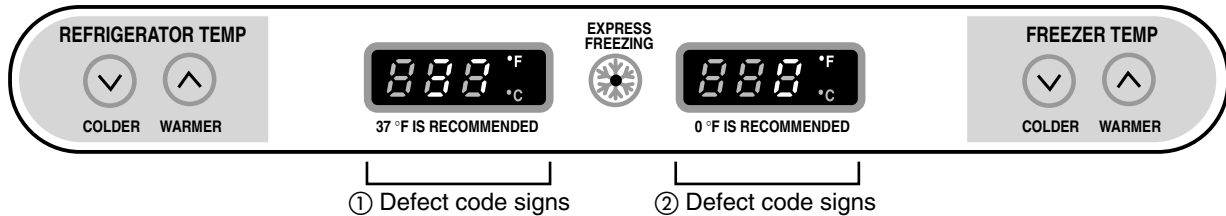

ERROR CODE on display panel

NO	ITEM	ERROR CODE		CONTENTS	REMARKS
		①	②		
1	Failure of freezer sensor	Er	F5	Cut or short circuit wire	Inspect Connecting wires on each sensor
2	Failure of Refrigerator sensor	Er	r5	Cut or short circuit wire	
3	Failure of defrost sensor	Er	d5	Cut or short circuit wire	
4	Failure of Room Temperature sensor	When display check mode: Er rt		Cut or short circuit wire	
5	Failure of defrost mode	Er	dH	When defrost sensor doesn't reach 8°C within 2 hours after starting defrost.	Snapping of defrost heater or Temperature fuse, pull-out of connector (indicated minimum 2 hours after failure occurs)
6	Failure of BLDC Fan Motor at Freezing Compartment	Er	FF	If there is no fan motor signal for more than 65sec in operation fan motor	Poor motor, hooking to wires of fan, contact of structures to fan, snapping or short circuit of Lead wires

Note 1) Room Temperature Sensor is not indicated on the failure indicating part but indicated in checking Display. (When pressing for more than the warmer key of Refrigerator Temp. and the warmer key of Freezer Temp for more than 1 second).

* LED check function: If simultaneously pressing the warmer key of Refrigerator Temp and the warmer key of Freezer Temp for a second, all display LED graphics on. If releasing the button, the LED graphics displays the previous status.

8-1-11 TEST Mode

1. The Test mode allows checking the PCB and the function of the product as well as finding out the defective part in case of an error.
2. The test mode is operated by pressing two buttons at Display panel.
3. While in the test mode, the function control button is not recognized, but the recognition tone (beep~) sounds.
4. After exiting the test mode, be sure to reset by unplugging and then plugging in the appliance.
5. If an error, such as a sensor failure, is detected while in the test mode, the test mode is cleared and the error code is displayed.
6. While an error code is displayed, the test mode will not be activated.

MODE	MANIPULATION	CONTENTS	REMARKS
TEST1	Push Express Freezing Key and COLDER KEY of Freezer Temp. at the Same time over 3 seconds. OR Push TEST S/W (in the main Board) Once.	1) Continuous operation of the COMPRESSOR and the Freezer fan 2) Stepping DAMPER OPEN 3) Defrosting HEATER OFF 4) DISPLAY LED all ON	
TEST2	Push Express Freezing Key and COLDER KEY of Freezer Temp. at the Same time over 3 seconds. In TEST MODE 1 OR Push TEST S/W Once in TEST MODE 1	1) Continuous operation of the COMPRESSOR and the Freezer fan 2) Stepping DAMPER CLOSE 3) Defrosting HEATER OFF 4) DISPLAY LED ahows no. 2	
TEST3	Push Express Freezing Key and COLDER KEY of Freezer Temp. at the Same time over 3 seconds. In TEST MODE 2 OR Push TEST S/W Once in TEST MODE 2	1) COMPRESSOR and the Freezer fan OFF 2) Stepping DAMPER CLOSE 3) Defrosting HEATER ON 4) DISPLAY LED ahows no. 3	Reset if the Temperature of the Defrosting sensor is 46°F (8°C) or more.
Reset	Push Express Freezing Key and COLDER KEY of Freezer Temp. at the Same time over 3 seconds. In TEST MODE 3 OR Push TEST S/W Once in TEST MODE 3	Reset to the previously setting Before TEST MODE	The compressor will Start after a 7-minute Delay.

* Freezer Fan RPM Variable Check:

In case the freezer fan is in operation when the WARMER KEY in Refrigerator and Freezer Temp. Control are pressed for more than one second at the same time freezer fan RPM changes. (for example if high speed, to normal speed or if normal speed, to high speed for 30 seconds)
After 30 seconds, it turns to its original RPM.

* Demonstration MODE:

1. When the KEY of refrigerator Temp. control or of freezer Temp. control is pushed and held over 5 seconds, warmest temperature's It converts to Demonstration Mode.
2. In this status, each LED is rotated with 1 second interval.
3. In this status, all Loads are off (Compressor / Fan / Damper / Heater)
(Even is Demonstration Mode, the refrigerator Lamp automatic off function works normally and can be demonstrated)
4. It reset if you do again as clause.

8-2-2 Oscillation Circuit

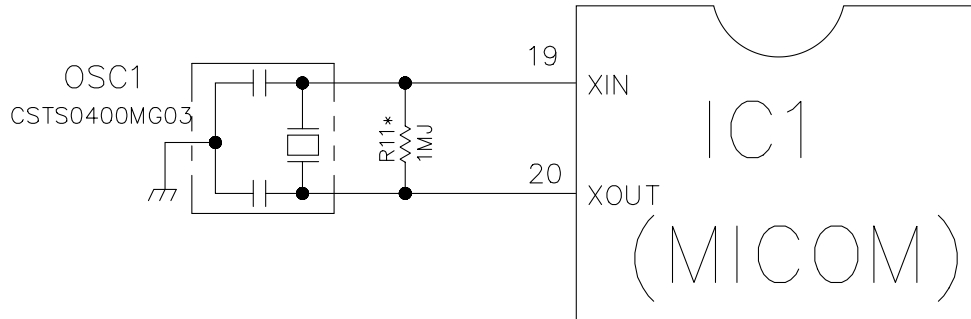

This circuit generates the base clock for calculating time and the synchro clock for transmitting data from and to the inside logic elements of the IC1 (MICOM). Be sure to use specific replacement parts, since calculating time by the IC1 may be changed. If changed, the OSC1 SPEC will not work.

8-2-3 Reset Circuit

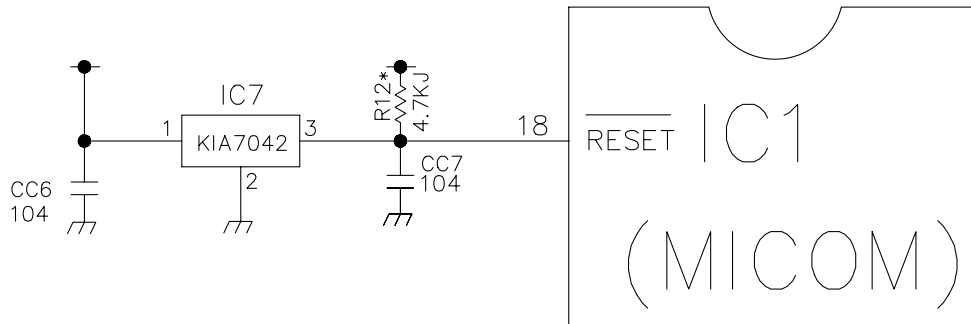

The RESET circuit allows all the functions to start at the initial conditions by initializing various parts, including the RAM inside the MICOM (IC1) when the power is initially supplied or the power supply to the MICOM is restored after a momentary power failure. For the initial 10ms of power supply, LOW voltage is applied to the MICOM RESET terminal. During a normal operation, 5V is applied to the RESET terminal. (If a malfunction occurs in the RESET IC, the MICOM will not operate.)

8-2-4 Load / Buzzer Drive & Open Door Detection Circuit

1. Load Drive Condition Check

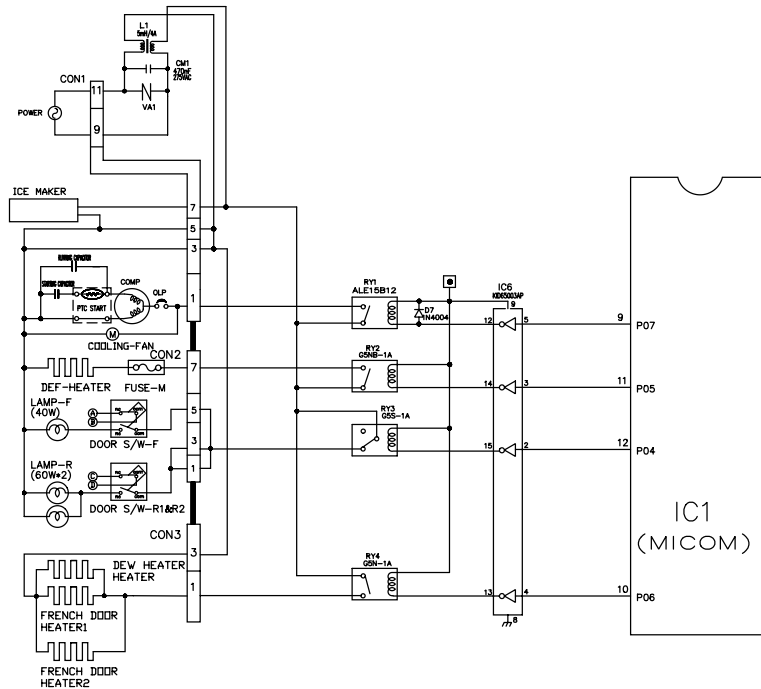

LOAD TYPE		COMP	DEFROSTING HEATER	LAMP	FRENCH DOOR HEATER 1, 2 / DEW HEATER
Measurement Location (IC6)		NO.12	NO.14	NO.15	NO.13
Condition	ON	1V or below			
	OFF	12V			

2. Fan motor driving circuit (freezing compartment fan)

1. This circuit makes standby power 0 by cutting off power supplied to ISs inside of the fan motor in the fan motor OFF.
2. This is a circuit to perform a temporary change of speed for the fan motor and applies DC voltage up to 7.5V ~ 16V to motor.
3. This circuit prevents over-driving the fan motor by cutting off power applied to the fan motor in the lock of fan motor by sensing the operation RPM of the fan motor.

	Ⓐ part	Ⓑ part	Ⓒ part
MOTOR OFF	2V or less	0V	5V
MOTOR ON	13V~15V	0V	2V~3V

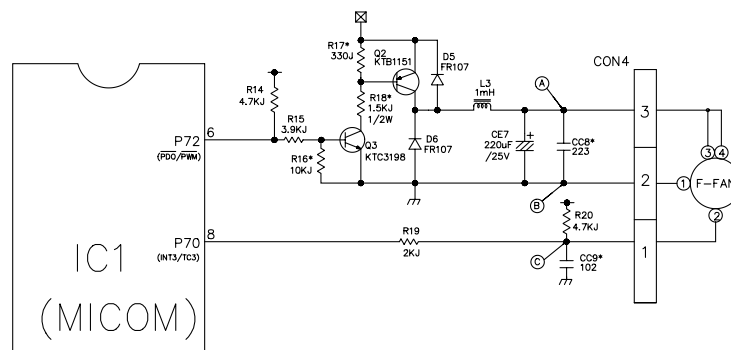

2. Buzzer Drive Condition Check

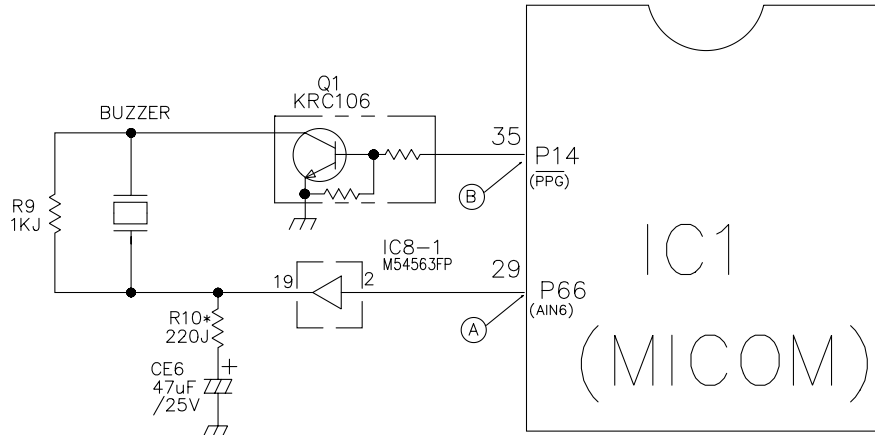

Condition Measurement Location	Tone (Ding~Dong~) when the button on the display is pushed.	Alarm for open door (beep-beep-beep)	OFF
IC1 (A)			0 V
IC1 (B)			0 V

3. Open Door Detection Circuit Check

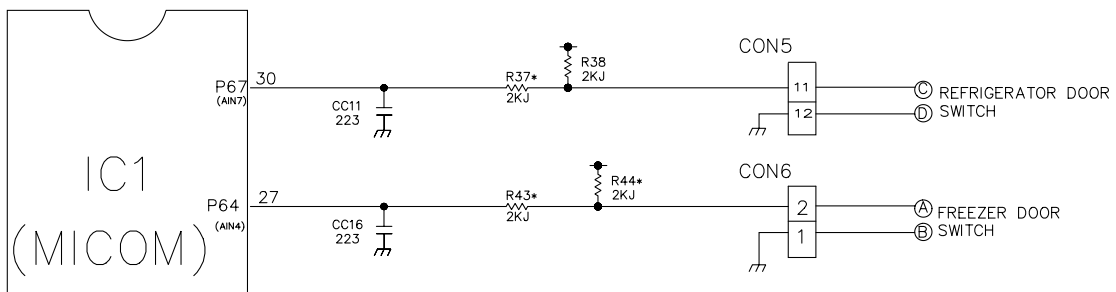

Measurement Location Freezer/ Refrigerator Door	(PIN NO.30 & PIN NO.27)
Closed	5 V
Open	0 V

8-2-5 Temperature Sensor Circuit

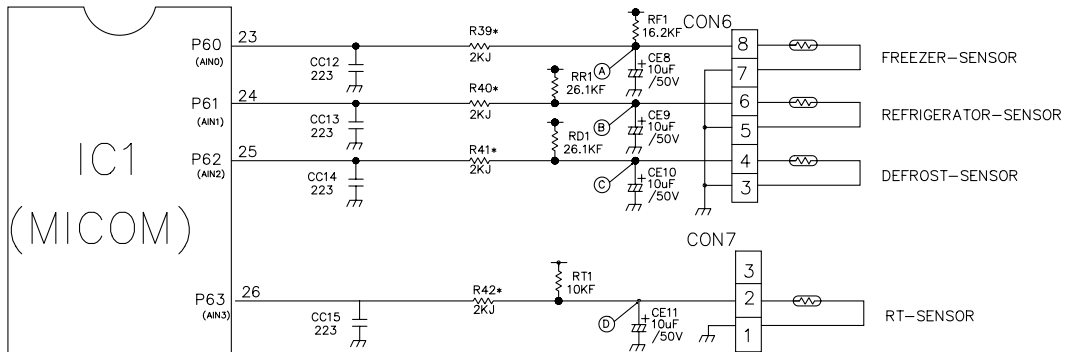

The upper CIRCUIT reads REFRIGERATOR temperature, FREEZER Temperature, and DEFROST-SENSOR temperature for defrosting and the indoor temperature for compensating for the surrounding temperature into MICOM. OPENING or SHORT state of each TEMPERATURE SENSOR are as follows:

SENSOR	CHECK POINT	NORMAL (-30°C ~ 50°C)	SHORT-CIRCUITED	OPEN
Freezer Sensor	POINT Ⓐ Voltage	0.5 V ~ 4.5 V	0 V	5 V
Refrigerator Sensor	POINT Ⓑ Voltage			
Defrosting Sensor	POINT Ⓒ Voltage			
Room Temperature sensor	POINT Ⓓ Voltage			

8-2-6 Refrigeration Compartment Stepping Motor Damper Circuit

* The circuit shown below is the damper circuit to regulate the refrigerator temperature.

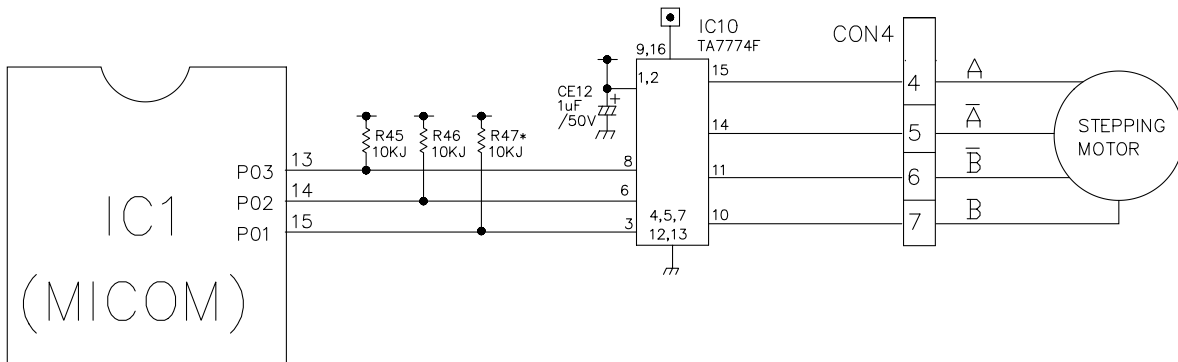

8-2-7 Key Button Input & Display Light-On Circuit

▶ The circuit shown above determines whether a function control key on the operation display is pushed. It also turns on the corresponding function indication LED (LED Module) SEVEN SEGMENT DISPLAY (SEVEN SEGMENT DISPLAY MODULE). The drive type is the scan type

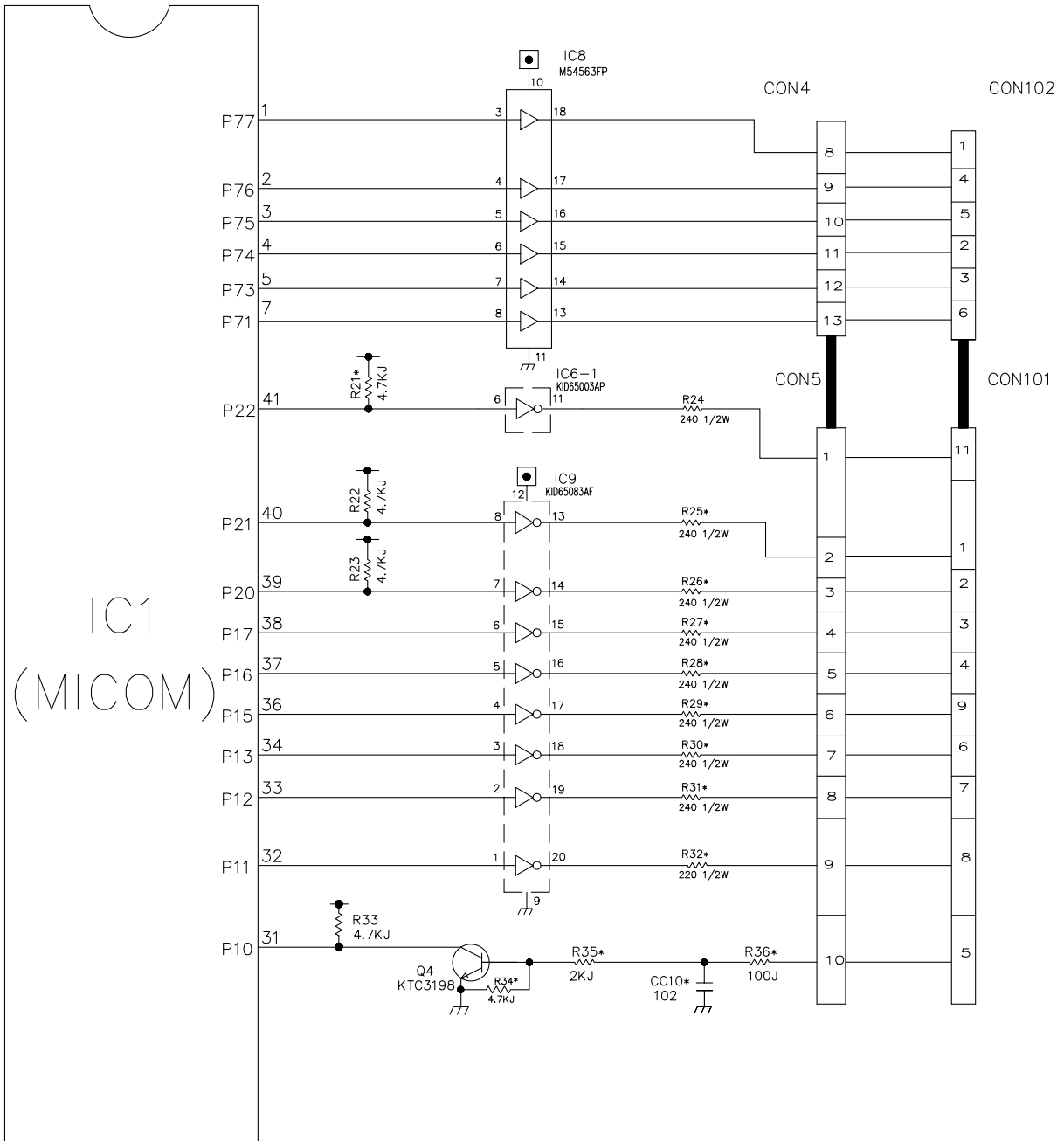

8-3 RESISTANCE SPECIFICATION OF SENSOR

TEMPERATURE	RESISTANCE OF FREEZER SENSOR	RESISTANCE OF REFRIGERATOR & DEFROST SENSOR & ROOM SENSOR
- 20 °C (-4 °F)	22.3 KΩ	77 KΩ
- 15 °C (5 °F)	16.9 KΩ	60 KΩ
- 10 °C (14 °F)	13.0 KΩ	47.3 KΩ
- 5 °C (23 °F)	10.1 KΩ	38.4 KΩ
0 °C (32 °F)	7.8 KΩ	30 KΩ
+ 5 °C (41 °F)	6.2 KΩ	24.1 KΩ
+ 10 °C (50 °F)	4.9 KΩ	19.5 KΩ
+ 15 °C (59 °F)	3.9 KΩ	15.9 KΩ
+ 20 °C (68 °F)	3.1 KΩ	13 KΩ
+ 25 °C (77 °F)	2.5 KΩ	11 KΩ
+ 30 °C (86 °F)	2.0 KΩ	8.9 KΩ
+ 40 °C (104 °F)	1.4 KΩ	6.2 KΩ
+ 50 °C (122 °F)	0.8 KΩ	4.3 KΩ

- The resistance of the SENSOR has a $\pm 5\%$ common difference.
- Measure the resistance of the SENSOR after leaving it for over 3 minutes in the measuring temperature. This delay is necessary due to sensor response speed.

8-4 TROUBLESHOOTING

PROBLEM	INDICATED BY	CHECK	CHECKING METHOD	CAUSE	SOLUTION
POWER SOURCE is poor.	1. The whole DISPLAY LED/SEVEN SEGMENT DISPLAY is off. 2. DISPLAY LED/SEVEN SEGMENT DISPLAY operates abnormally	1. FREEZER/REFRIGERATOR.	Check if FREEZER/REFRIGERATOR DOOR IS OPEN and check display.	POWER SOURCE is poor.	Check outlet Voltage.
		2. If LAMP is dim.	Check visually.	Applied voltage error.	Use boosting TRANS.
		3. The connection of the MAIN PWB CONNECTOR.	Check connection of CONNECTOR.	CONNECTOR connection is poor.	Reconnect CONNECTOR.
		CONNECTOR.	TRANS FUSE is open.	Replace TRANS.	
COOLING is poor.	NO COOLING.	1. If the COMPRESSOR operate.	USE TEST MODE1 (forced COOLING). If less than 7 minutes pass after compressor shuts off, don't press the KEY and wait.	COMPRESSOR locked or blocked. OLP, PTC is poor. COMPRESSOR RELAY is poor. THE CONNECTING WIRE is poor.	Replace COMPRESSOR. Replace OLP, PTC. Replace MAIN PWB. Check the connection of the black wire of the MAIN PWB CONNECTOR (CON1).
FREEZER TEMPERATURE is incorrect	1. If FAN MOTOR operates. USE TEST MODE1 (forced COOLING).	2. If refrigerant is leaking.	Measure the amount of frost sticking on EVAPORATOR and the surface temperature of the condenser pipe.	Refrigerant leakage.	Replace the leaking part and replace any lost refrigerant.
		1. If FAN MOTOR operates.	USE TEST MODE1 (forced COOLING).	FAN MOTOR is poor. CONNECTING WIRE is poor.	Replace the FAN MOTOR. Refer to 8-2-4. 2 and check
		2. If DEFROSTING is normal.	Check the amount of frost sticking on the EVAPORATOR.	DEFROSTING is poor.	See DEFROSTING is poor.
		3. If SENSOR is normal.	Check the resistance of the Refrigerator SENSOR.	SENSOR RESISTANCE is poor.	Replace SENSOR.
		4. Door Line contact.	Check the seal when the door is closed.	Door liner damaged.	Replace door liner.

PROBLEM	INDICATED BY	CHECK	CHECKING METHOD	CAUSE	SOLUTION
COOLING is poor.	If REFRIGERATOR TEMPERATURE is too low.	1. If FREEZER TEMPERATURE is normal.	Check is FREEZER TEMPERATURE is too low.		Make sure the DOOR is attached.
		2. If amount of cool air from FAN MOTOR is sufficient.	Make sure that the amount and speed of cool air are sufficient by touching the check supplied on the REFRIGERATOR.	FAN MOTOR is poor. Passage of cool air is blocked. EVA frozen.	Replace FAN MOTOR. Remove impurities. See DEFROSTING is poor.
		3. Door Line contact.	Check door seal when door is closed.	Door liner damaged.	Replace Door liner.
DEFROSTING is poor.	NO DEFROSTING.	1. If HEATER emits heat.	USE TEST MODE2 (forced DEFROSTING).	HEATER disconnection.	Replace HEATER.
				TEMPERATURE FUSE disconnection.	Replace TEMPERATURE FUSE.
				Connection is poor.	Check EVAPORATOR connection and wire of MAIN PWB CONNECTOR.
				DEFROST-SENSOR is poor.	Replace DEFROST-SENSOR.
				HEATER RELAY is poor.	Replace RY2 of MAIN PWB.
				DRAIN PIPE is blocked.	Remove ice and impurities. Check HEATER PLATE resistance.
		3. If ice remains after DEFROSTING.	Make sure that DEFROST SENSOR is connected. Make sure that FREEZER / REFRIGERATOR DOOR is closed.	Connection is poor. DOOR does not close properly.	Reassemble the DEFROST-SENSOR. Reassemble DOOR. Replace GASKET.

8-5-2 Replacement Parts List

WORK APPLICATION	No	P/NO	DESCRIPTION	SPEC	MAKER	REMARK
	1	6870JB0131A	PWB(PCB)	BETTER BRAVO-PJT	DOO SAN	T=16
	2	6170JB2012A	TRANSFORMER,SMPSC001L	DL-PJT 2.9MH/20W	SAM IL	TRANS
	3	6170JB2012C	TRANSFORMER,SMPSC001L	GR-207,Bl DC 100V-127V	SAM IL	TRANS
	4	6630VM0111	CONNECTOR (CIRC),WAFER	YW396 YEDNHD 11P 3.96MM YW396-11AV (1P-2,4,6,8,10)	YEDN HD	C0N1
	5	6630AG9106C	CONNECTOR (CIRC),WAFER	YW396-07AV YEDNHD 7PIN 3.96MM STRAIGHT SN	YEDN HD	C0N2
	6	6630AG9106A	CONNECTOR (CIRC),WAFER	YW396-03AV	YEDN HD	C0N3
	7	6630JB8004M	CONNECTOR (CIRC),WAFER	SMW250 YEDNHD 13P 2.5MM STRAIGHT SN	YEDN HD	C0N4
	8	6630JB8004L	CONNECTOR (CIRC),WAFER	SMW250 YEDNHD 12P 2.5MM STRAIGHT SN	YEDN HD	C0N5
	9	6630JB8004G	CONNECTOR (CIRC),WAFER	SMW250 YEDNHD 8P 2.5MM STRAIGHT SN	YEDN HD	C0N6
	10	6630JB8004B	CONNECTOR (CIRC),WAFER	SMW250 YEDNHD 3P 2.5MM STRAIGHT SN	YEDN HD	C0N7
	11	01ZZJB20440	IC,DRAWING	IMP87C846N 42P SDIP BK MASK BRAVO-PJT BETTER	TOSHIBA	IC1 (=01ZZJB2044R)
	12	01KE431000A	IC,KEC	KIA431 3 PIN TP - -	KEC	IC4
	13	01KE650030B	IC,KEC	KID65003AP 16P,SDIP BK DRIVE IC	KEC	IC6
	14	01KE650830B	IC,KEC	KID65083AF 20P SDIP ST LED DRIVER(CTR ARRAY)	KEC	IC9
	15	01KE704200A	IC,KEC	KIA7042P KEC 3P BK RESET	KEC	IC7
	16	01KE780500W	IC,LINEAR	KIA7805P1 - - -	KEC	IC5
	17	01PMGNE001A	IC,POWER MANAGEMENT	PS2561L1-1-V NEC 4P,DIP BK = TLP721F	NEC	IC3
	18	01SK635100A	IC,POWER MANAGEMENT	STR-G6351 5PIN BK SMP5 2,4PIN FORM	SANKEN	IC2
	19	01STLM1001A	IC,STANDARD LOGIC	M54563FP MITSUBISHI 20 R/TP CONVERT	MITSUBISHI	IC8
	20	01TD77400A	IC,DRAWING	TA7774AP 16,SDIP BK DRIVE,IC STEPPING MOTOR	TOSHIBA	IC10
	21	6920000001A	RELAY	ALF15B12 MATSUSHITA 250VAC 16A 12VDC 1A NO VENTING	NAIS	RY1
	22	6920JB2003A	RELAY	GSN-1A DMRON 250VAC 1.5A 12VDC 1A JAPAN	DMRON	RY4
	23	6920JB2003D	RELAY	GSNB-1A-F DMRON 250VAC 5A 12VDC 1A NO VENTING	DMRON	RY2
	24	6920JB2009B	RELAY	GSB-14 DMRON 250VAC 5A 12VDC 1C NO VENTING	DMRON	RY3
	25	6212JB8001B	RESONATOR,CERAMIC	CST30400MG03 MURATA 4MHZ 1P -	MURATA	DSC1
	26	6102JB8001B	VARISTOR	INR14D621 ILJIN UL/VDE BK 620V	IL JIN	VA1
	27	6102W5V007A	VARISTOR	INR14D331K IL JIN UL/CSA/VDE BK	IL JIN	VA1
	28	0DB360000AA	DIODE,RECTIFIERS	D3SBA60 BK SHINDENGEN - 600V 4A 80A - 10UA	SHINDENGEN	BD1
	29	0DD400409AC	DIODE,RECTIFIERS	RECTIN4004 TP	DELTA	D7
	30	0DR107009AA	DIODE,RECTIFIERS	FR107 TP RECTRON DD41 1000V 1A 30A 500NSEC 5A	DELTA	DL,D2,D5,D6
	31	0DRSA00070A	DIODE,RECTIFIERS	RL 2 SANKEN BK NDN 400V 2A 40A 50NSEC 10UA	SANKEN	D3,D4
	32	0CE105BK63B	CAPACITOR,FIXED ELECTROLYTIC	1UF KME,RG,IX 50V 0.2 FMS TP 5	SAM WHA	CE12
	33	0CE105FK63B	CAPACITOR,FIXED ELECTROLYTIC	10UF KMG 50V 20% FMS TP 5	SAM WHA	CE1 (=CE11)
	34	0CE227BF 63B	CAPACITOR,FIXED ELECTROLYTIC	220UF KME TYPE 16V 20% FMS TP 5	SAM WHA	CE5
	35	0CE227BH63B	CAPACITOR,FIXED ELECTROLYTIC	220UF KME,RG 25V 20% FMS TP 5	SAM WHA	CE7
	36	0CE476BH63B	CAPACITOR,FIXED ELECTROLYTIC	47UF KME,RG,IX 25V 0.2 FMS TP 5	SAM WHA	CE6
	37	0CE476BK63B	CAPACITOR,FIXED ELECTROLYTIC	47UF KME TYPE 50V 20% FMS TP 5	SAM WHA	CE2
	38	0CE476V6F0	CAPACITOR,FIXED ELECTROLYTIC	47UF HF 450V 20% BULK SNAP IN	SAM WHA	CE1
	39	0CE687VH6F0	CAPACITOR,FIXED ELECTROLYTIC	680UF RX 25V 20% BULK SNAP IN	SAM WHA	CE3
	40	0CE687VJ61B	CAPACITOR,FIXED ELECTROLYTIC	680UF RX 35V 20% TP 5 F	SAM WHA	CE4
	41	0CK102DK96A	CAPACITOR,FIXED CERAMIC(HIGH DIELECTRIC)	1NF 2012 50V 80%-20% R/TP X7R	MURATA	CC9,CC10
	42	0CK1040K949	CAPACITOR,FIXED CERAMIC(High dielectric)	0.1UF D 50V 80%-20% FCY5V TA52	SAM WHA	CC3,CC4,CC6,CC7
	43	0CK104DK94A	CAPACITOR,FIXED CERAMIC(HIGH DIELECTRIC)	100NF 2012 50V 80%-20% R/TP FCY5V	MURATA	CC5
	44	0CK22102510	CAPACITOR,FIXED CERAMIC(High dielectric)	220P 2KV K B S	SAM WHA	CC2
	45	0CK2230K949	CAPACITOR,FIXED CERAMIC(High dielectric)	22NF 50V Z F TA52	SAM WHA	CC11-CC16
	46	0CK2230K96A	CAPACITOR,FIXED CERAMIC(HIGH DIELECTRIC)	22NF 2012 50V 80%-20% R/TP X7R	MURATA	CC8
	47	0CK4710K519	CAPACITOR,FIXED CERAMIC(High dielectric)	470PF 50V K B TA52	SAM WHA	CC1
	47	0CG1031N509	CAPACITOR,FIXED FILM	0.01UF D 100V 10% PE TP5	SAM WHA	CM4
	48	0CG4732Y430	CAPACITOR,FIXED FILM	47000PF S 630V 5% M/PE NI R	SAM WHA	CM3
	49	0CG47418670	CAPACITOR,FIXED FILM	0.47UF D 275V 20% M/PP NI R	SAM WHA	CM1,CM2
	50	0RD1001G609	RESISTOR,FIXED CARBON FILM	1K OHM 1/4 W 5% TA52	SMART	R9
	51	0RD1002G609	RESISTOR,FIXED CARBON FILM	10K OHM 1/4 W 5% TA52	SMART	R45,R46
	52	0RD2001G609	RESISTOR,FIXED CARBON FILM	2K OHM 1/4 W 5% TA52	SMART	R19,R38
	53	0RD3901G609	RESISTOR,FIXED CARBON FILM	3.9K OHM 1/4 W 5% TA52	SMART	R15
	53	0RD4701G609	RESISTOR,FIXED CARBON FILM	4.7K OHM 1/4 W 5% TA52	SMART	R4,14,20,22,23,33
	54	0RD5603H609	RESISTOR,FIXED CARBON FILM	560K OHM 1/2 W 5% TA52	SMART	R2
	55	0RH1000L622	RESISTOR,METAL GLAZED(CHIP)	100 OHM 1 / 8 W 5% 2012 R/TP	R0HM	R36
	56	0RH1001L622	RESISTOR,METAL GLAZED(CHIP)	1K OHM 1/8 W 5% 2012 R/TP	R0HM	R8
	57	0RH1002L622	RESISTOR,METAL GLAZED(CHIP)	10K OHM 1/8 W 5% 2012 R/TP	R0HM	R13,R16,R47
	58	0RH1004L622	RESISTOR,METAL GLAZED(CHIP)	100OHM 1/8 W 5% 2012 R/TP	R0HM	R11
	59	0RH1801L622	RESISTOR,METAL GLAZED(CHIP)	18K OHM 1 / 8 W 5% 2012 5.00% D	R0HM	R7
	60	0RH2001L622	RESISTOR,METAL GLAZED(CHIP)	2K OHM 1 / 8 W 5% 2012 R/TP	R0HM	R35,R37,R39-R44
	61	0RH2200L622	RESISTOR,METAL GLAZED(CHIP)	220 OHM 1/8 W 5% 2012 R/TP	R0HM	R10
	62	0RH3300L622	RESISTOR,METAL GLAZED(CHIP)	330 OHM 1/8 W 5% 2012 R/TP	R0HM	R17
	63	0RH4701L622	RESISTOR,METAL GLAZED(CHIP)	4.7K OHM 1/8 W 5% 2012 R/TP	R0HM	R12,R21,R34
	64	0RJ0332E672	RESISTOR,METAL GLAZED(CHIP)	33 OHM 1/8 W 5% 2012 R/TP	R0HM	R5
	65	0RJ1501H672	RESISTOR,METAL GLAZED(CHIP)	15K OHM 1/2 W 5% 2012 R/TP	R0HM	R18
	66	0RJ2200H672	RESISTOR,METAL GLAZED(CHIP)	220 OHM 1/2 W 5% 2012 R/TP	R0HM	R32
	67	0RJ2401E472	RESISTOR,METAL GLAZED(CHIP)	2.4K OHM 1/8 W 1% 2012 R/TP	R0HM	RL2
	68	0RJ6800E672	RESISTOR,METAL GLAZED(CHIP)	680 OHM 1/8 W 5% 2012 R/TP	R0HM	R6
	69					
	70	0RJ2400H672	RESISTOR,METAL GLAZED(CHIP)	240 OHM 1/2 W 5% 2012 R/TP	R0HM	R25-R31
	71	0RD2400G609	RESISTOR,METAL GLAZED(CHIP)	240 OHM 1/2 W 5% TA52	SMART	R24
	72	0RJ9101E472	RESISTOR,METAL GLAZED(CHIP)	9.1K OHM 1/8 W 1% 2012 R/TP	R0HM	RL1
	73	0RNI002G409	RESISTOR,FIXED METAL FILM	10K OHM 1/4 W 1.00% TA52	SMART	RT1
	74	0RN1622G409	RESISTOR,FIXED METAL FILM	16.2K OHM 1/4 W 1.00% TA52	SMART	RF1
	75	0RN2612G409	RESISTOR,FIXED METAL FILM	26.1K OHM 1/4 W 1.00% TA52	SMART	RL1,RLD1
	76	0RS010J609	RESISTOR,FIXED METAL OXIDE FILM	1 OHM 1 W 5.00% TA52	SMART	R0CP
	77	0RS0470J609	RESISTOR,FIXED METAL OXIDE FILM	0.47 OHM 1 W 5% TA52	SMART	R0CP
	78	0RS1503J609	RESISTOR,FIXED METAL OXIDE FILM	150K OHM 1 W 5.00% TA52	SMART	R1
	79	0RS5602K641	RESISTOR,FIXED METAL OXIDE FILM	56K OHM 2 W 5.00% F20	SMART	R3
	80	0RS8202J609	RESISTOR,FIXED METAL OXIDE FILM	82K OHM 1 W 5.00% TA52	SMART	R1
	81	0LR1001M4F0	INDUCTOR,RADIAL LEAD	1000UH 20% R 6X12.5 BULK	TNC	L3
	82	0TR319809AA	TRANSISTOR	KTC3198-TP-Y (KTC1815)KEC	KEC	Q3,Q4
	84	0TRKE00008A	TRANSISTOR,BIPOLARS	KEC KT8181 BK TD126 60V 5A	KEC	Q2
	84	0TRKE80016A	TRANSISTOR,BIPOLARS	KEC KRC106S R/TP SPT2 50V 100MA	KEC	Q5
	85	0FZZJB3001A	FUSE,DRAWING	2A 250V - SLOW-BLOW LIT TELF USE, TRIAD	SAM JU KYO YUK	FUSE1
	86	6200JB8004A	FILTFER(CIRC),EMC	CV940050 TNC - -	TNC	L1
	87	6200JB8007X	FILTFER(CIRC),EMC	UV11-05320 TNC BK 0.5A 320MH	TNC	L2
	88	6210JB8001A	FILTFER(CIRC),EMC	RF33510A0 SAMWHA TP52 BEAD FILTER	SAM WHA	FBI
	89	6854B50001A	JUMP WIRE	0.6MM 52MM TP TAPING SN	DAE A LEAD	J27(8MM) J8-11,03-07,14,16,18,22-26(10MM) J01,01,12,13,15,17,19,20(12.5MM) J21(15MM)
	90	6600RR1001Z	SWITCH,TACT	JTP1280A6 JEIL 12VDC 50MA -	JEIL	SW1
	91	6908JB3002D	BUZZER	PQ272207PL-20C-2000 SUNWAY PIEZO 2KHZ 80DB (CHINA)	SUN WAY	BUZZER
	92	4920JB3007A	HEAT SINK	23.3X17.25 DRIVE IC STR-R-S64.65,73 2PIN 1-SCREW 3MM -	(IC2)	(IC2)
	93	15BF0302418	SCREW TAP TITE(S),BINDING HEAD	+ D3.0 L8.0 MSWR3/FZY	HAENG SUNG	
	94	49111004	SDLEDER,SDLEDERING	NA HEESUNG METAL BAR SN 63% NA	-	-
	95	59333105	FLUX	JS-71 KDKI SANET KOREA(KSK) SG.0.808 +/-0.003	-	-
	96	9VVF0120000	SDLEDER(RSOSIN WIRE) RSO	DI.20	-	-

8-5-3 PWB Assembly, Display, And Parts List

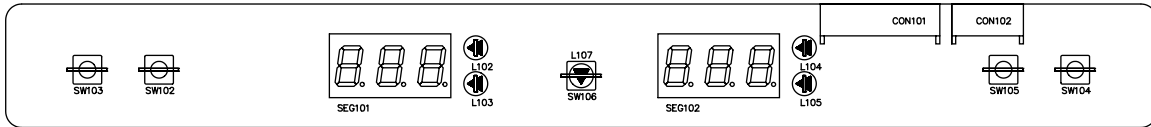

No	P/NO	DESCRIPTION	SPEC	MAKER	REMARK
1	6870JB8090A	PWB(PCB)	KS-PJT DISPENSER DISPLAY	DOO SAN	-
2	-	-	-	-	-
3	6630JB8005D	WAFER	SMAW250-11	YEON HO	CON101
4	6630JB8004U	-	SMAW250-06	-	CON102
5	6600JB8005A	SWITCH,TACT	KPT-1105A	KYUNG IN	-
6	6600RRT002K	-	JTP1230A JEIL 12V DC 50MA	JEIL	SW102~105
7	6600JB8004A	TACT S/W	KPT-1109R	KYUNG IN	-
8	-	TACT S/W	KPT-1109G	KYUNG IN	SW106
9	6327JB8001A	DISPLAY LED ASSEMBLY	LN4023-13EWRS GREEN 2.1V 1.7MCD	LEDTECH	SEG1,SEG2
10	0DLLE0059AA	LED	LT8323-41-BCN 2.1V D3 TP GREEN	-	L102~105
11	0DD414809AA	DIODE,SWITCHING	1N4148 26MM	PYUNG CHANG	D107~113
12	0DD400400A	-	1N4004	DELTA	D101~106
13	6854B50001A	JUMP WIRE	0.6MM 52MM TP TAPING SNC(10MM)	-	J01~06,J08~13
14	9VWF0120000	SOLDER<RODIN WIRE> RS0	D1.20	HEE SUNG	-
15	49111004	SOLDER,SOLDERING	H63A	-	-
16	59333105	FLUX	SGJ0.825-0.830 KOREA F.H-206	KOKI	-

8-6 PWB DIAGRAM

8-6-1 PWB Main Assembly

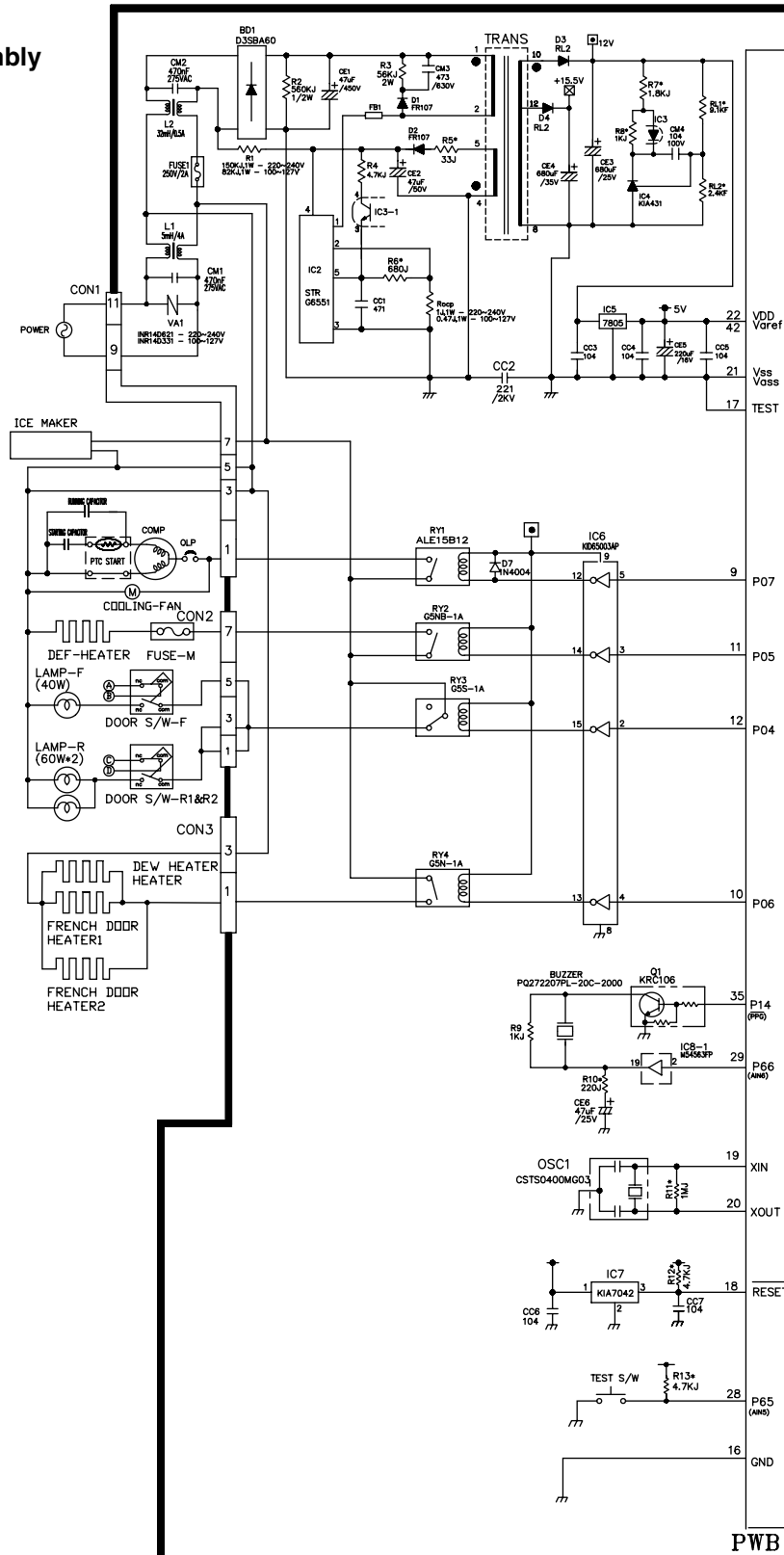

*:SMD부품임.

FIG.1

TOSHIBA TMP87C846N(IC1)

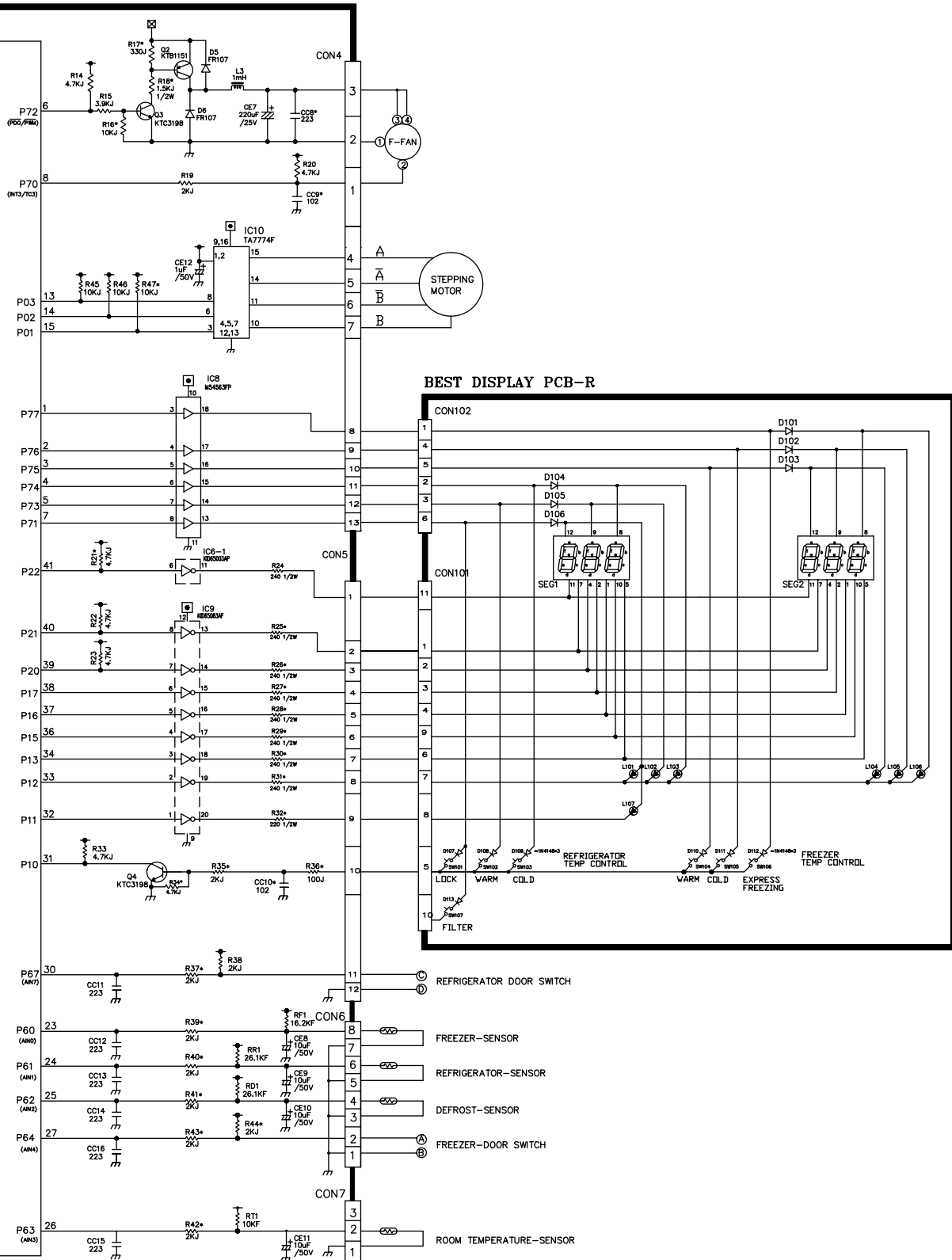

9. EXPLODED VIEW & REPLACEMENT PARTS LIST

CASE PARTS

CAUTION: Use the part number to order part, not the position number.

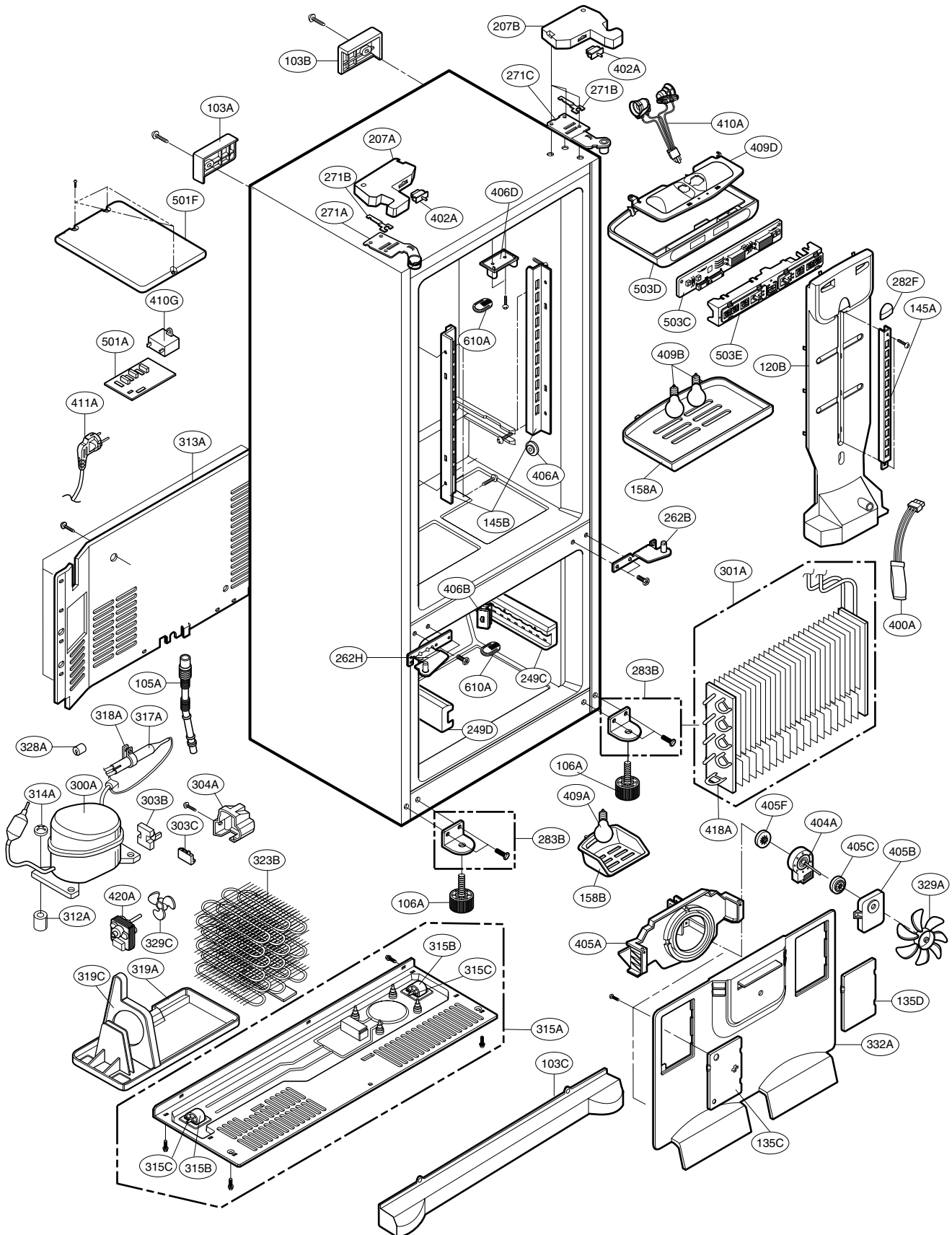

FREEZER PARTS

CAUTION: Use the part number to order part, not the position number.

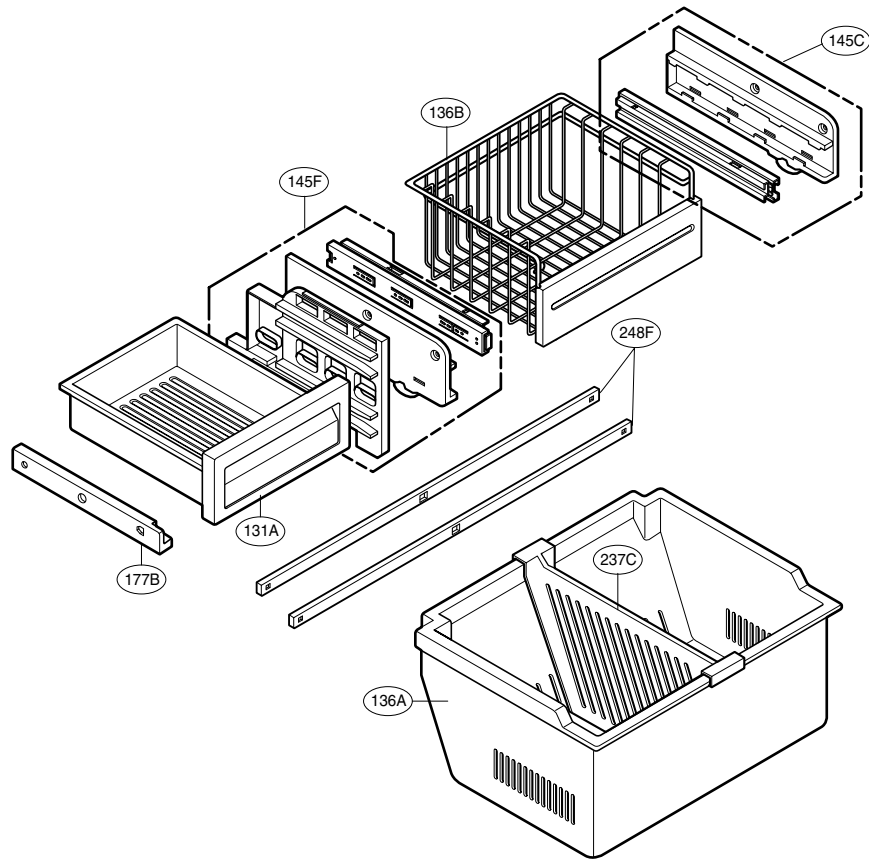

REFRIGERATOR PARTS

CAUTION: Use the part number to order part, not the position number.

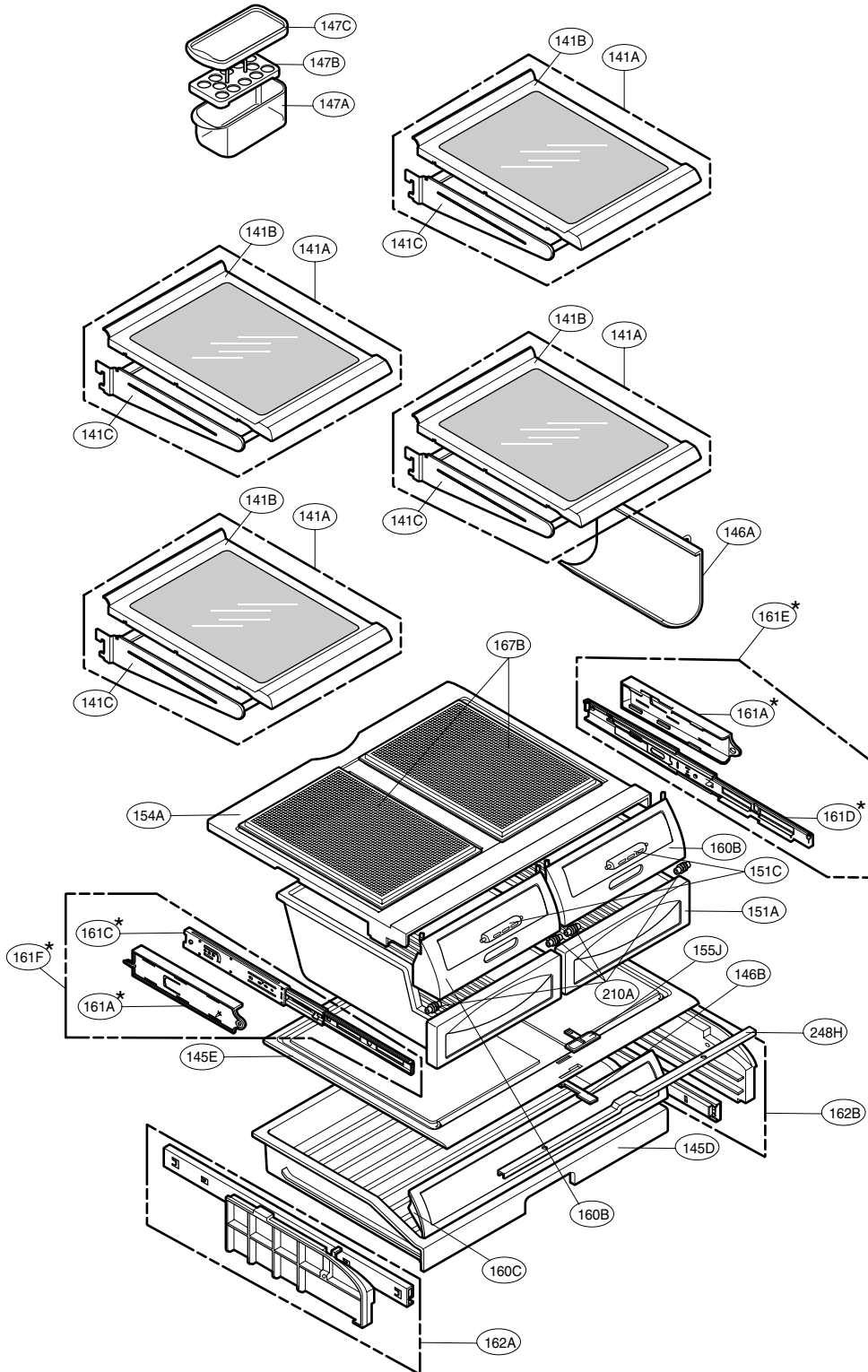

* : on some models

DOOR PARTS

CAUTION: Use the part number to order part, not the position number.

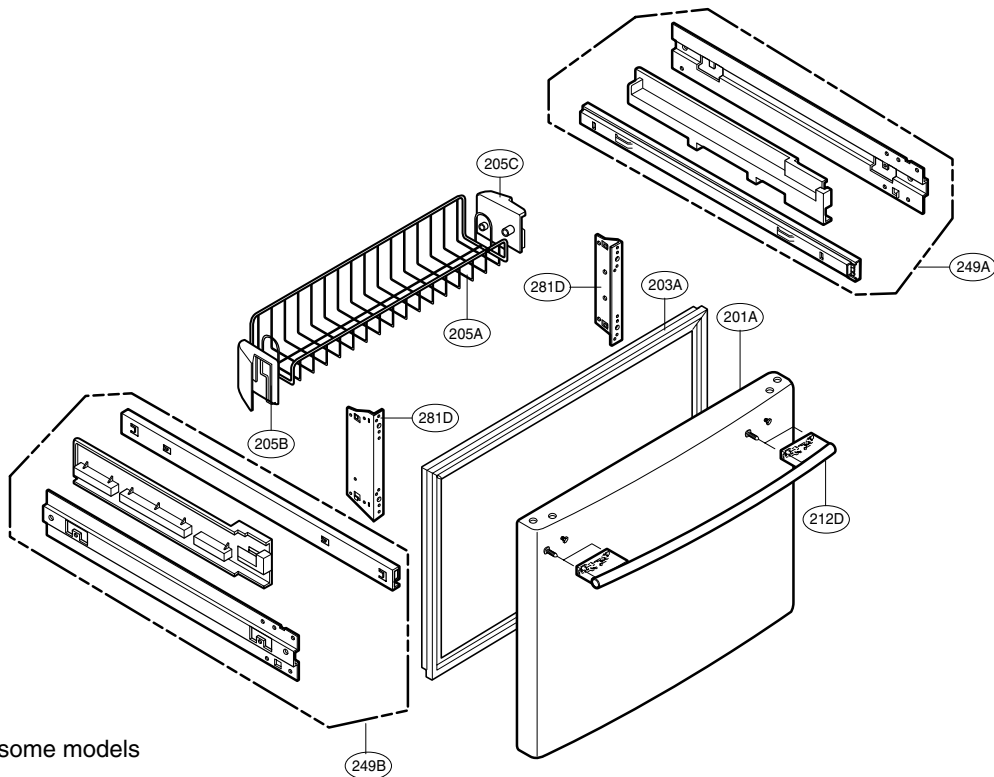
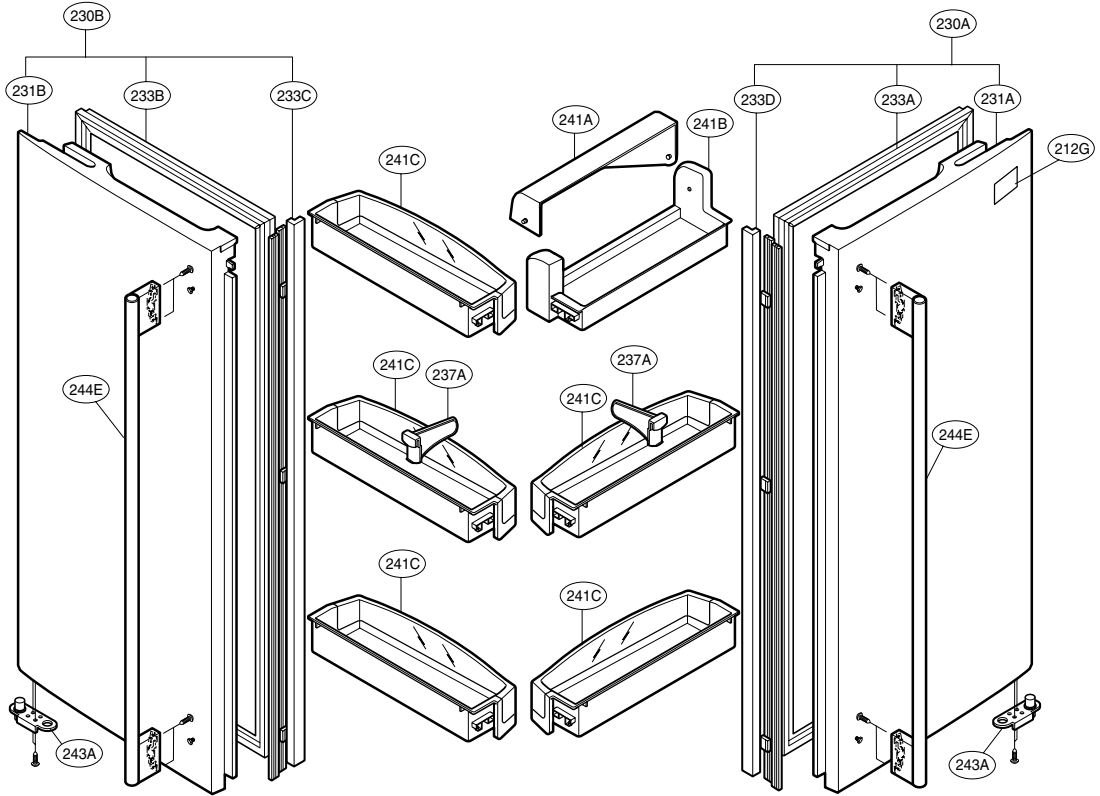

* : on some models

ICE & MAKER PARTS

CAUTION: Use the part number to order part, not the position number.

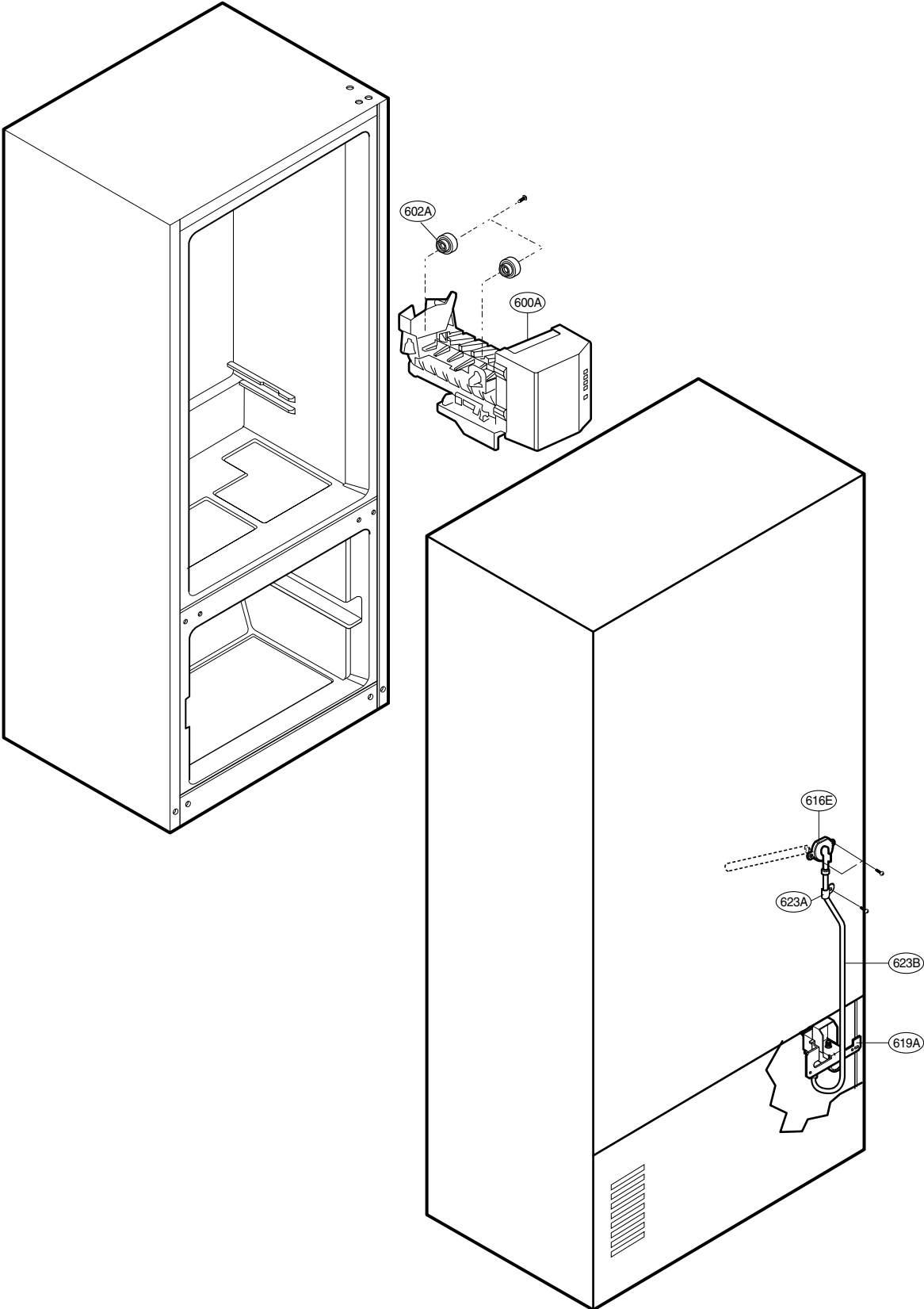



P/No. 3828JL8031C

APR., 2004 Printed in Korea