



<http://Biz.lgservice.com>

# REFRIGERATOR

# SERVICE MANUAL

**CAUTION**  
BEFORE SERVICING THE UNIT,  
READ THE SAFETY PRECAUTIONS IN THIS MANUAL.

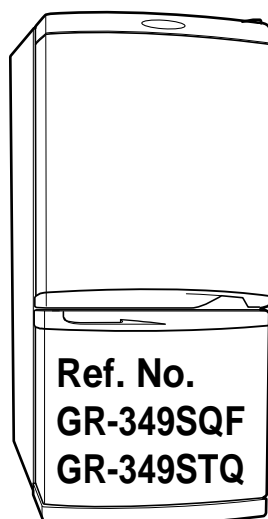

**MODEL: LRBP1031W**  
**LRBP1031NI**

**COLOR: EURO WHITE**

# CONTENTS

---

<b>SAFETY PRECAUTIONS</b> .....	<b>2</b>
<b>SERVICING PRECAUTIONS</b> .....	<b>3</b>
<b>SPECIFICATIONS</b> .....	<b>4</b>
<b>PARTS IDENTIFICATION</b> .....	<b>5</b>
<b>REPLACEMENT OF DOOR OPENING TYPE</b> .....	<b>6</b>
<b>DISASSEMBLY</b> .....	<b>7-8</b>
DOOR.....	7
DOOR SWITCH.....	7
FAN AND FAN MOTOR.....	7
DEFROST CONTROL ASSEMBLY .....	8
LAMP .....	8
<b>ADJUSTMENT</b> .....	<b>9-10</b>
COMPRESSOR.....	9
PTC-STARTER.....	9
OLP (OVERLOAD PROTECTOR) .....	10
<b>CIRCUIT DIAGRAM</b> .....	<b>10</b>
<b>TROUBLESHOOTING</b> .....	<b>11-16</b>
COMPRESSOR AND ELECTRIC COMPONENTS.....	11
PTC AND OLP.....	12
OTHER ELECTRIC COMPONENT .....	13
SERVICE DIAGNOSIS CHART.....	14
REFRIGERATING CYCLE .....	15-16
<b>MICOM FUNCTION &amp; PCB CIRCUIT EXPLANATION</b> .....	<b>17-33</b>
<b>EXPLODED VIEW</b> .....	<b>34-35</b>
<b>REPLACEMENT PARTS LIST</b> .....	<b>36-</b>

# SAFETY PRECAUTIONS

---

Please read the following instructions before servicing your refrigerator.

1. Check the set for electric leakage.
2. Unplug prior to servicing to prevent electric shock.
3. Whenever testing with power on, wear rubber gloves to prevent electric shock.
4. If you use any kind of appliance, check regular current, voltage, and capacity.
5. Don't touch metal products in the freezer with wet hands. This may cause frostbite.
6. Prevent water from flowing onto electric elements in the mechanical parts.
7. When standing up after having checked the lower section of the refrigerator with the upper door open, move with care to avoid hitting the upper door.
8. When tilting the set, remove any materials on the set, especially the thin plates (ex. glass shelf or books.)
9. When servicing the evaporator, wear cotton gloves. This is to prevent injuries from the sharp evaporator fins.
10. Leave the disassembly of the refrigerating cycle to a specialized service center. The gas inside the circuit may pollute the environment.

# SERVICING PRECAUTIONS

## Air Recharging in Compressor

Test the refrigeration by connecting it electrically before refilling operation. It is necessary to ascertain the function of the motor-compressor and identify the defects immediately. If defects have been found, empty the old system of possible R134a residue by breaking off the end of the extension piece at its narrow point. (Figure 1) Replace the filter and any damaged components. Unsolder and pull off the piece remaining inside the service tube and then attach an complete extension with male Hansen, and solder it to the same tube again. (Figure 2)

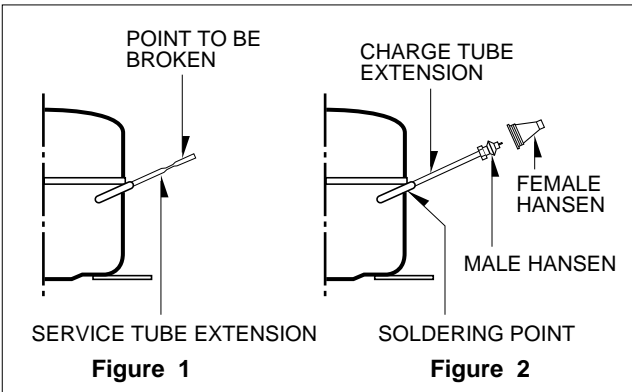

It is necessary to execute the soldering operation with valve open so that the fumes caused by oil residue can come out freely without blowholes between two tubes during the heating of the point to be soldered. The extension fitted with the male Hansen is connected to the female fitting of the vacuum pump tube. (Figure 3)

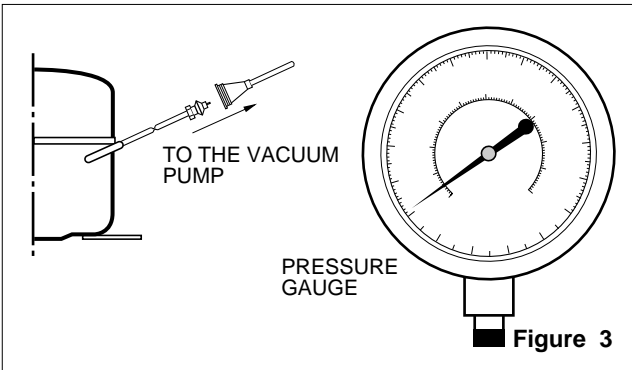

Air evacuating from the system begins as soon as the pump starts. The refrigeration system must be kept under vacuum until the reading on the low-pressure gauge indicates vacuum (0 absolute, -1 atm., -760 mm hg) in any case it is advisable to keep the pump running for about 30 minutes. (Figure 3)

In case that a considerable leakage occurs it will be necessary to stop the vacuum pump and to add a small quantity of Freon to the system, if vacuum should not be obtained (pressure gauge can't fall to 1 atmosphere), start the refrigeration unit and find the leakage with the special leak-finder. When the defective soldering point is visible, re-do it after opening the extension tube valve and reestablishing the normal outside pressure inside the group.

Because the melted alloy is sucked into the tubes and blocks them, the pressure must be rebalanced when vacuum is in the system in soldering. As soon as the

vacuum operation is over, add the quantity in grams of R134a to the refrigeration system. Remember that every system has an exact quantity of R134a with a tolerance of  $\pm 5$  grams that can be added. (Figure 4)

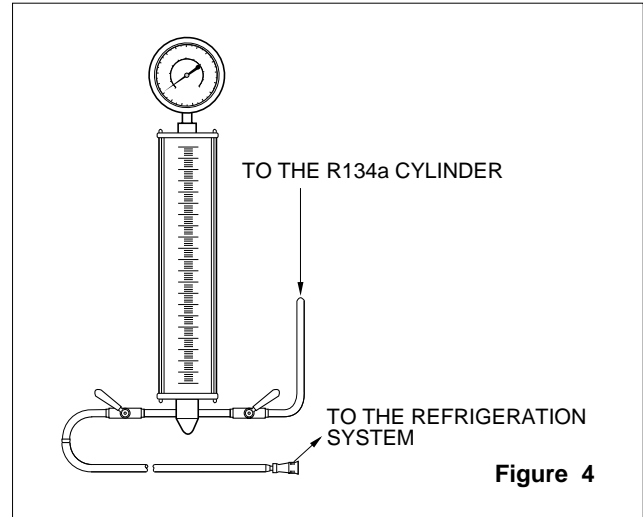

Before performing this operation (if the vacuum pump and refilling cylinder are connected), make sure that the valve placed between the vacuum pump and the refilling tube are closed in order to keep the Freon for addition to the system. (Figure 5)

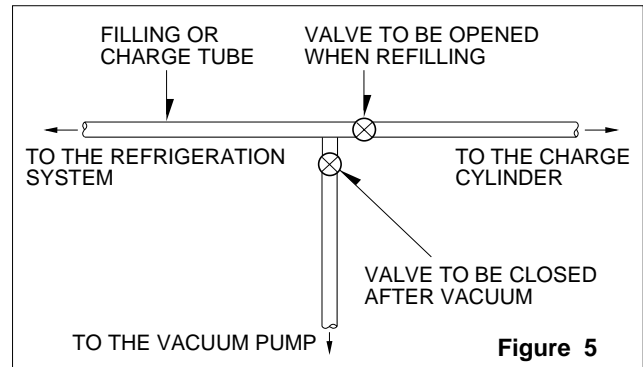

In addition, check the graduated scale on the cylinder for the quantity of R134a to be added, for example, if we have 750 grams of Freon in the cylinder and must add 165 grams to the group, this amount will be reached when R-134a has dropped to 585 grams, remembering that the indicator shows a lower limit of meniscus. Do this after choosing the scale corresponding to the gas pressure different scales reported as the same gas pressure indicated by the pressure gauge on the top of the column.

To make R134a flow into the system, open the valve placed at the base of the cylinder and connected to the filling tube. The amount of Freon cannot be added to the system all at once because it may cause a blocking of the motor-compressor. Therefore, proceed by adding the original quantity of about 20-30 grams and close the valve immediately.

The pressure rises and the motor compressor must start sucking the gas and lowering the pressure again.

Regulate the valve again, in the safe way until reaching the quantity of R134a established for the system being charged. When the system is running, the suction pressure must be stabilized between 0.30 to 0.6 atmosphere.

# SPECIFICATIONS

## 1. Ref. No: GR-349\*\*\*\*

ITEMS		SPECIFICATIONS	ITEMS	SPECIFICATIONS
DIMENSIONS (mm)		595(W)×626(D)×1710(H)	REFRIGERATOR COMPARTMENT	Transparent Shelf (2 EA)
NET WEIGHT (kg)		69		Vegetable Container (2 EA)
COOLING SYSTEM		Fan Cooling		Vegetable Container Cover (1 EA)
TEMPERATURE CONTROL	REFRIGERATOR	Knob Dial		Chilled Container (1 EA)
	FREEZER	Button	DOOR POCKET	Dairy Pocket Cover (1 EA)
DEFROSTING SYSTEM		Full Automatic		Egg Tray (1 EA)
		Heater Defrost		Little Pocket (3 EA)
DOOR FINISH		Pre-Coated Metal or Vinyl Coated Metal		Bottle Pocket (1 EA)
OUT CASE		Painted Steel Sheet	FREEZER COMPARTMENT	Tray Drawer (4 EA)
INNER CASE		ABS		Ice Tray (1 EA)
INSULATION		Polyurethane Foam	COMPRESSOR	PTC Starting Type
DEFROSTING DEVICE		Heater, Sheath	EVAPORATOR	Fin Tube Type
REFRIGERANT		R134a (150 g)	CONDENSER	Side & Wire Condenser
LUBRICATION OIL		FREOL @ 22G (210 cc)		

# PARTS IDENTIFICATION

---

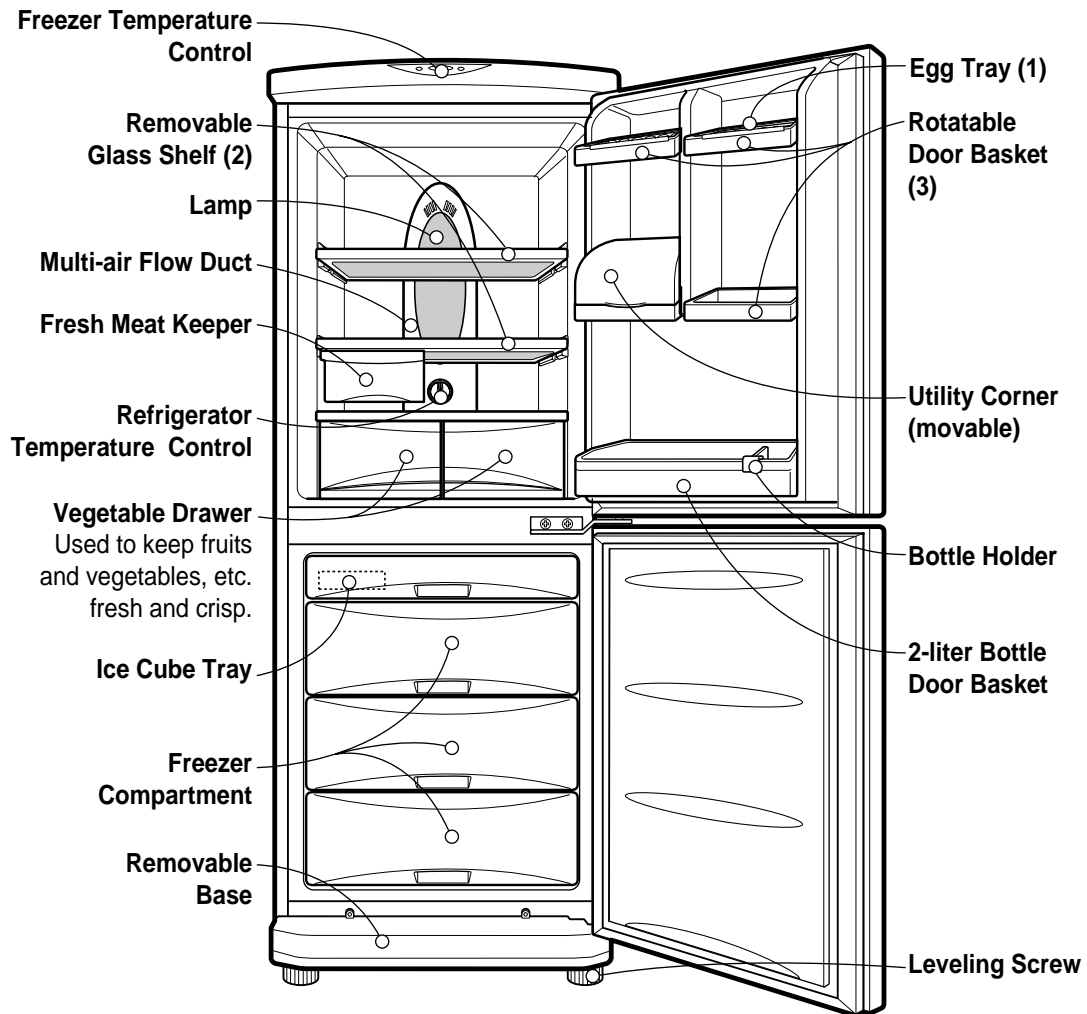

**NOTE :** This is a basic model. The shape of refrigerator is subject to change.

# REPLACEMENT OF DOOR OPENING TYPE

## 1. PRECAUTION

- 1) Before reversing the door, you should remove food and accessories like shelves or trays which are not fixed in the refrigerator.
- 2) Use Torque Wrench or Spanner to fix or remove the bolt.
- 3) Don't lay the refrigerator down in working with it, it will cause a malfunction.
- 4) Be careful not to drop the door in disassembling or assembling the freezer or the refrigerator door.

## 2. HOW TO REVERSE THE DOORS

- 1) Remove screw 2 and remove Cover 1 and move Cap Cover 3. And, remove screw 4, Hinge-L 5, and remove pin 6. Remove the Freezer Door 21, and move the position of the cap 7. Move the position of bracket door 8 and screw 9.

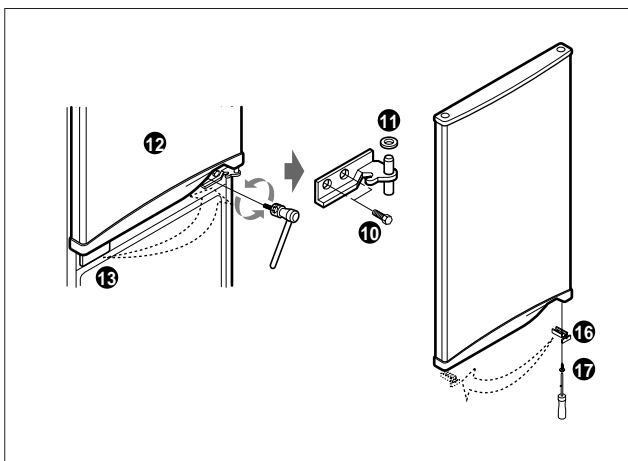
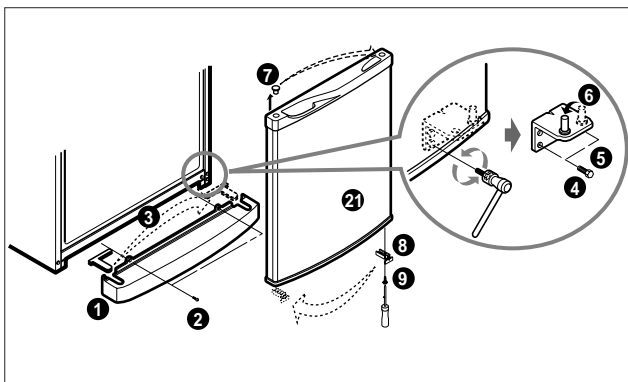

- 2) Remove bolt 10 and remove the Hinge-C 11 and the Fridge Door 12. Move the position of the cap 13. Move the position of bracket door 16 and screw 17.
- 3) Move the position of Hinge-U pin 14, and Cap, Top cover 15. Assemble the Fridge Door 12. Assemble Hinge-C 11 and bolt 10. Assemble F-Door 21. Assemble the Hinge-L 5 and bolt 4. Assemble Low Cover 1 and screw 2.

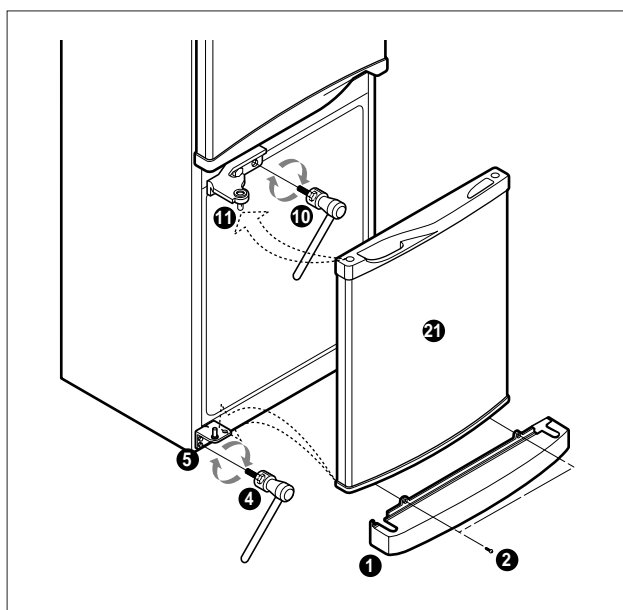
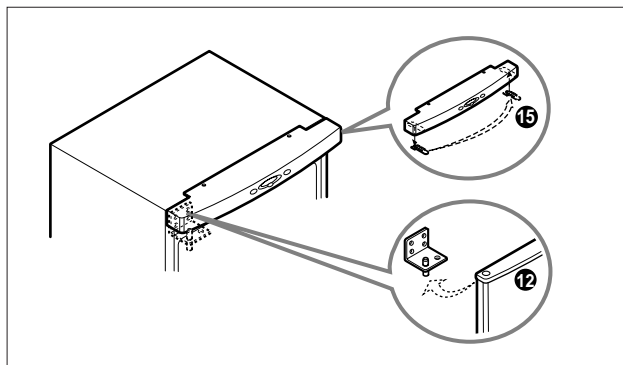
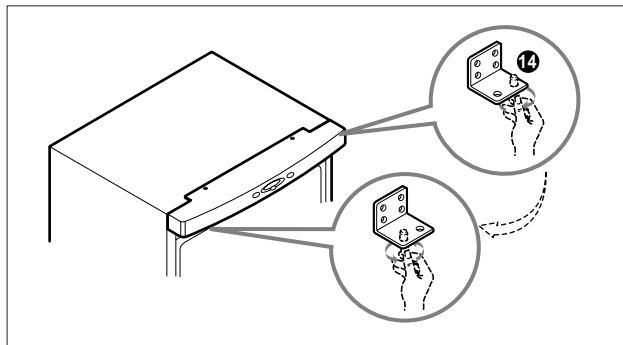

# DISASSEMBLY

## 1 DOOR

### ● Freezer Door

- 1) Loosen 2 screws and pull the Lower Cover.
- 2) Loosen hexagonal bolts fixing the lower hinge to the body to remove the freezer door only.

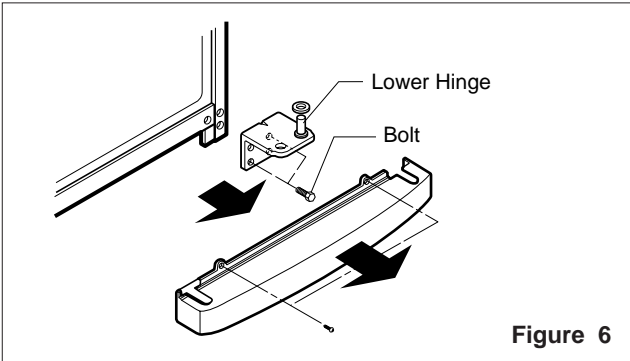

- 3) Pull out the Door Gasket to remove from the Door Foam Assembly, F.

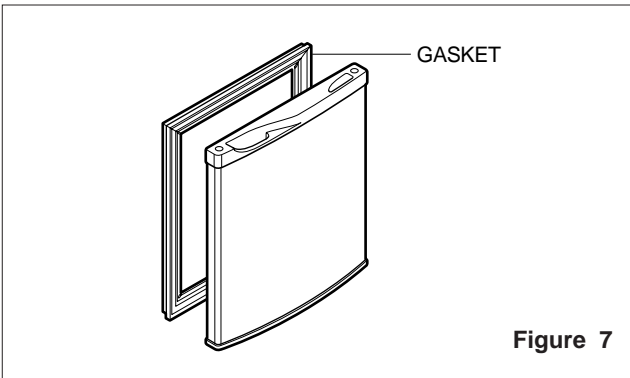

### ● Refrigerator Door

- 1) Loosen hexagonal bolts fixing the center hinge (Hinge,C) to the body to remove the refrigerator door only.

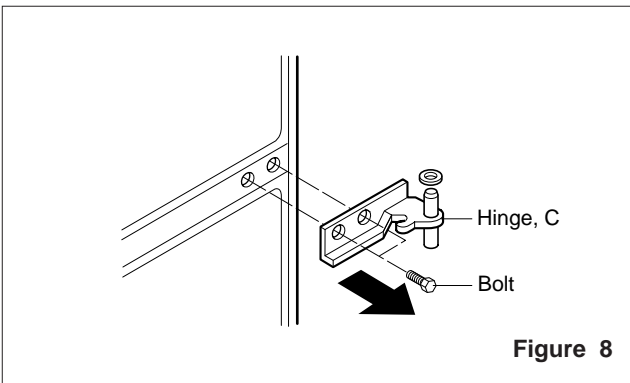

- 2) Pull out the Door Gasket to remove from the Door Foam Assembly, R.

## 2 DOOR SWITCH

- 1) Loosen four screws in upper part and disconnect top cover.
- 2) Disconnect Lead Wire from switch.
- 3) Disengage hook behind the switch by pressing it with hands.

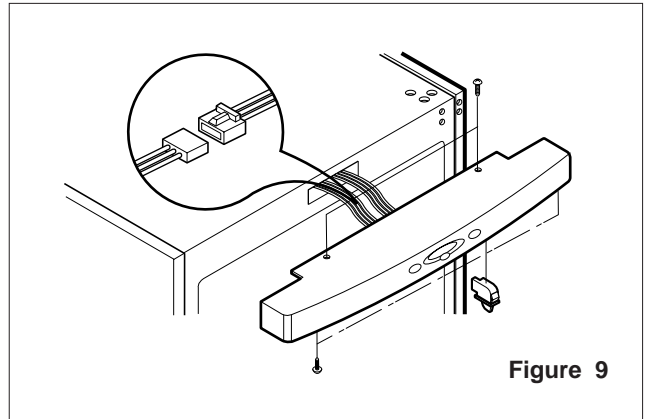

## 3 REFRIGERATOR LAMP

- 1) Remove the Cover Lamp by pulling with a slotted type driver.
- 2) Remove the lamp by turning.

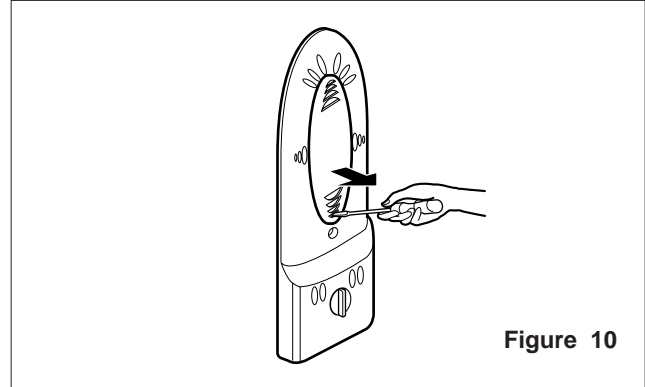

#### 4 FAN AND FAN MOTOR

- 1) Remove freezer drawers.
- 2) Remove two cap screws and loosen two screws in Grille Fan.
- 3) Pull out the Grille Fan and Shroud.
- 4) Disconnect the housing of lead wire.
- 5) Separate the Fan Assembly.
- 6) Lose 2 screw fixed to the Bracket.
- 7) Pull out Shroud to remove the Fan Motor Assembly.
- 8) Separate the Motor Bracket and Rubber.

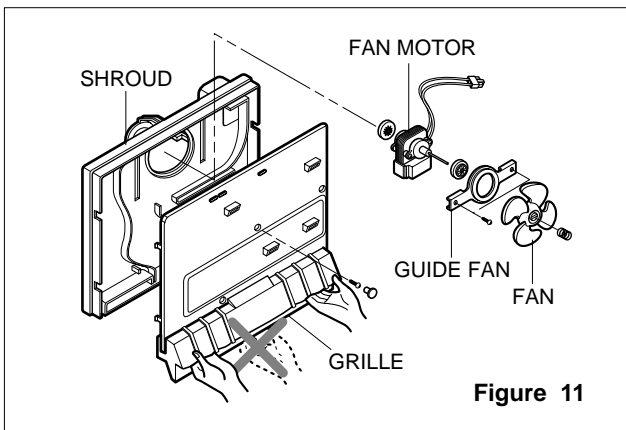

Figure 11

#### 5 DEFROST CONTROL ASSEMBLY

Defrost Control Assembly consists of Thermistor and Melting Fuse. Thermistor functions to defrost automatically and it is attached to metal side of the Evaporator and senses temperature. Melting Fuse is a kind of safety device for preventing overheating of the Heater when defrosting.

At the temperature of 72°C, it stops the emission of heat from the Heater.

- 1) Pull out the Shroud after removing the Grille.
- 2) Separate the connector connected with the Defrost Control Assembly and replace new one.

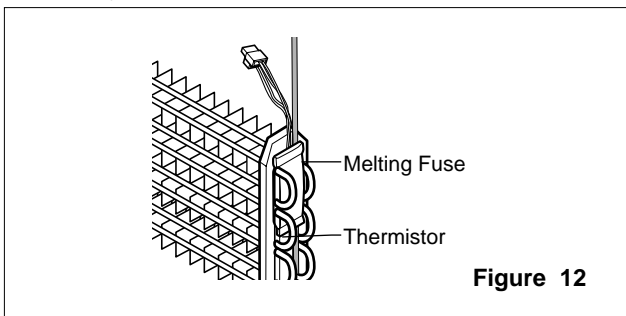

Figure 12

#### 6 DAMPER CONTROL

- 1) Remove the Cover Lamp and loosen 2 screw.
- 2) Pull the Control Box and separate the lead wire housing.
- 3) Remove the Cover Lamp.
- 4) Separate the Insulation Multi Duct and Control Box.
- 5) Disassemble the Knob.
- 6) Separate the Damper Control and Control Box.
- 7) Separate the Damper Control and Resistor.
- 8) Disconnect the lead wire.

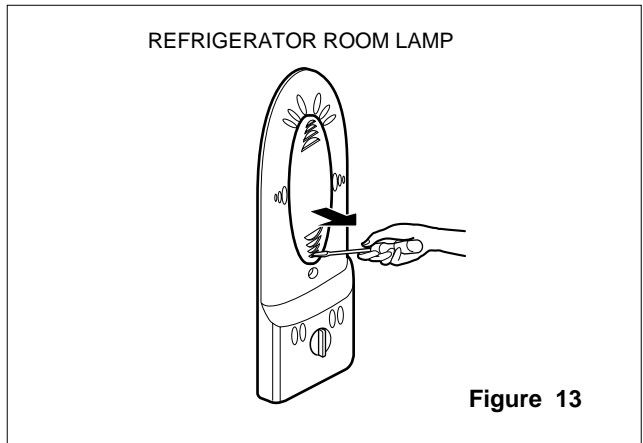

Figure 13

#### 7 HEATER, SHEATH

In this refrigerator, Heater, Sheath is used for defrosting heater. During heating, the temperature of heater rises about 300~500°C. Therefore, be careful not to burn yourself while servicing.

- 1) After removing the Grille and Shroud, separate the Heater Sheath by disconnecting the connectors.
- 2) Exchanged Heater Sheath and connect the housing.

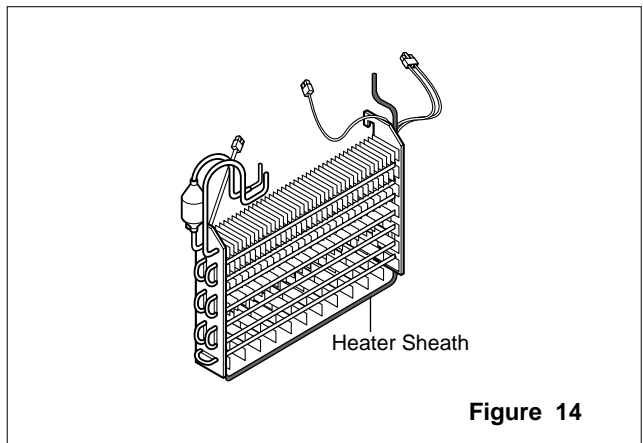

Figure 14



# ADJUSTMENT

## 1 COMPRESSOR

### 1) Role

The compressor intakes low temperature and low pressure gas evaporated from evaporator of the refrigerator, and condenses this gas to high temperature and high pressure gas, and then plays delivering role to Condenser.

### 2) Composition

The Compressor is composed of compressor apparatus compressing gas, compressor motor moving compressor apparatus, and case protecting compressor apparatus and motor. There are PTC-Starter, and Over Load Protector (OLP) in the Compressor outside. On the other hand, because the Compressor consists of 1/1000mm processing precision components and is sealed after production in absence of dust or humidity, deal and repair with care.

### 3) Note for Usage

- (1) Be careful not to allow over-voltage and over-current.
- (2) Do no strike.  
If applying forcible power or strike (dropping or careless dealing), poor operation and noise may occur.
- (3) Use proper electric components appropriate to the compressor.
- (4) Note to Keep Compressor dry.  
If compressor gets wet in the rain and rusts in the pin of hermetic terminal, the result may be poor operation from poor contact.
- (5) Be careful that dust, humidity, and welding flux don't flow in the compressor inside in replacing the compressor. Dust, humidity, and flux due to welding which inflows to cylinder may cause lockage and noise.

## 2 PTC-STARTER

### 1) Composition of PTC-Starter

- (1) PTC (Positive Temperature Coefficient) is a no-contact semiconductor starting device which uses ceramic material. This material consists of BaTiO<sub>3</sub>.
- (2) The higher the temperature is, the higher becomes the resistance value. These features are used as the starting device for the Motor.

### 2) Role of PTC-Starter

- (1) PTC is attached to hermetic compressor used for refrigerator, show case and starts motor.
- (2) Compressor for household refrigerator applies to single-phase induction Motor.  
For normal operation of the single-phase induction motor, in the starting operation current flows in both main coil and sub-coil. After the starting is over, the current in subcoil is cut off. The proper features of PTC play all the above roles. So, PTC is used as a motor starting device.

## 3) PTC-Applied Circuit Diagram

### ● According to Starting Method for the Motor

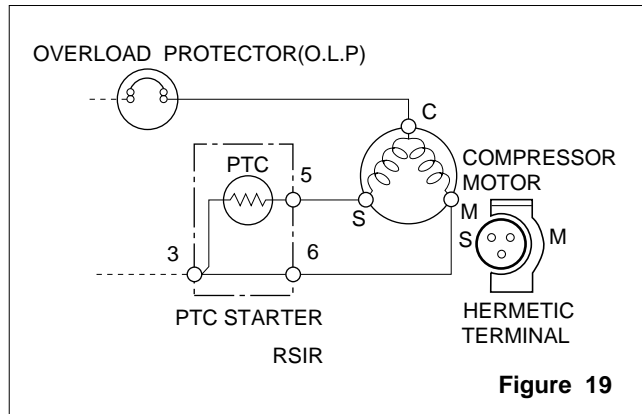

## 4) Motor Restarting and PTC Cooling

- (1) For restarting after power off during normal compressor motor operation, plug the power cord after 5 min. for pressure balance of refrigerating cycle and PTC cooling.
- (2) During normal operation of the Compressor Motor, PTC elements generate heat continuously. Therefore, if PTC isn't cooled for a while after the power has been shut off, the motor can't operate again.

## 5) Relation of PTC-Starter and OLP

- (1) If the power is off during operation of compressor and the power is on before the PTC is cooled, (instant shut-off within 2 min. or reconnect a power plug due to misconnecting), the PTC isn't cooled and a resistance value grows. As a result, current can't flow to the sub-coil and the motor can't operate and the OLP operates by flowing over current in only in the main-coil.
- (2) While the OLP repeats on and off operation about 3-5 times, PTC is cooled and compressor motor performs normal operation.  
If OLP doesn't operate when PTC is not cooled, compressor motor is worn away and causes a short circuit and fire. Therefore, use a properly fixed OLP without fail.

## 6) Note to Use PTC-Starter

- (1) Be careful not to allow over-voltage and over-current.
- (2) Do no strike.  
Don't apply a forcible power or strike.
- (3) Keep apart from any liquid.  
If liquid such as oil or water enters the PTC, PTC materials may break due to insulation breakdown of the material itself.
- (4) Don't change PTC at your convenience.  
Don't disassemble PTC and mold. If the exterior of the PTC-starter is damaged, resistance value is altered and it may cause poor starting of the compressor motor.
- (5) Use a properly repaired PTC.

### 3 OLP (OVER LOAD PROTECTOR)

#### 1) Definition of OLP

- (1) OLP (OVER LOAD PROTECTOR) is attached to the hermetic compressor and protects the motor by cutting off current in compressor motor in case of over-rising temperature by Bimetal in the OLP.
- (2) When over-voltage flows to Compressor motor, the bimetal works by heating the heater inside the OLP, and the OLP protects motor by cutting off current which flows to the compressor motor.

#### 2) Role of the OLP

- (1) The OLP is attached to the hermetic compressor used for the refrigerator and show case and prevents the motor coil from being started in the compressor.
- (2) Do not turn the adjust screw of the OLP in any way for normal operation of the OLP.  
(Composition and connection Diagram of OLP)

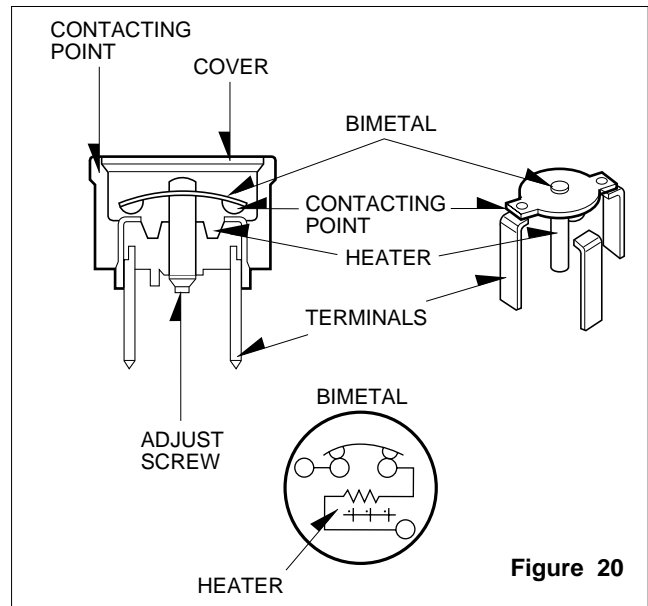
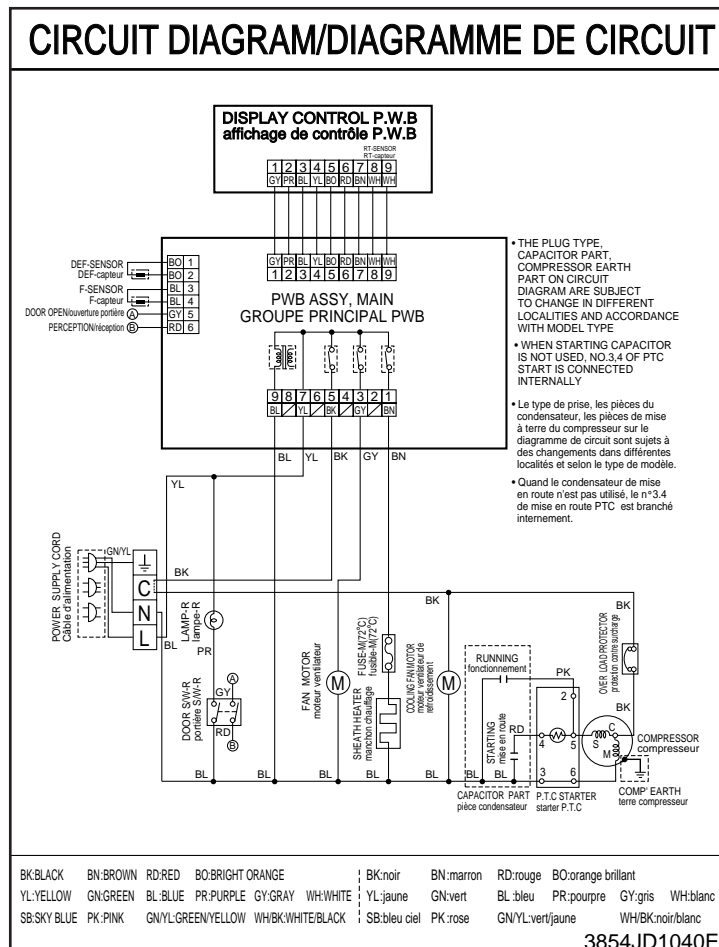

Figure 20

## CIRCUIT DIAGRAM



**NOTE :** This is a basic diagram and specifications vary in different localities.

# TROUBLESHOOTING (Mechanical Part)

## 1 COMPRESSOR AND ELECTRIC COMPONENTS

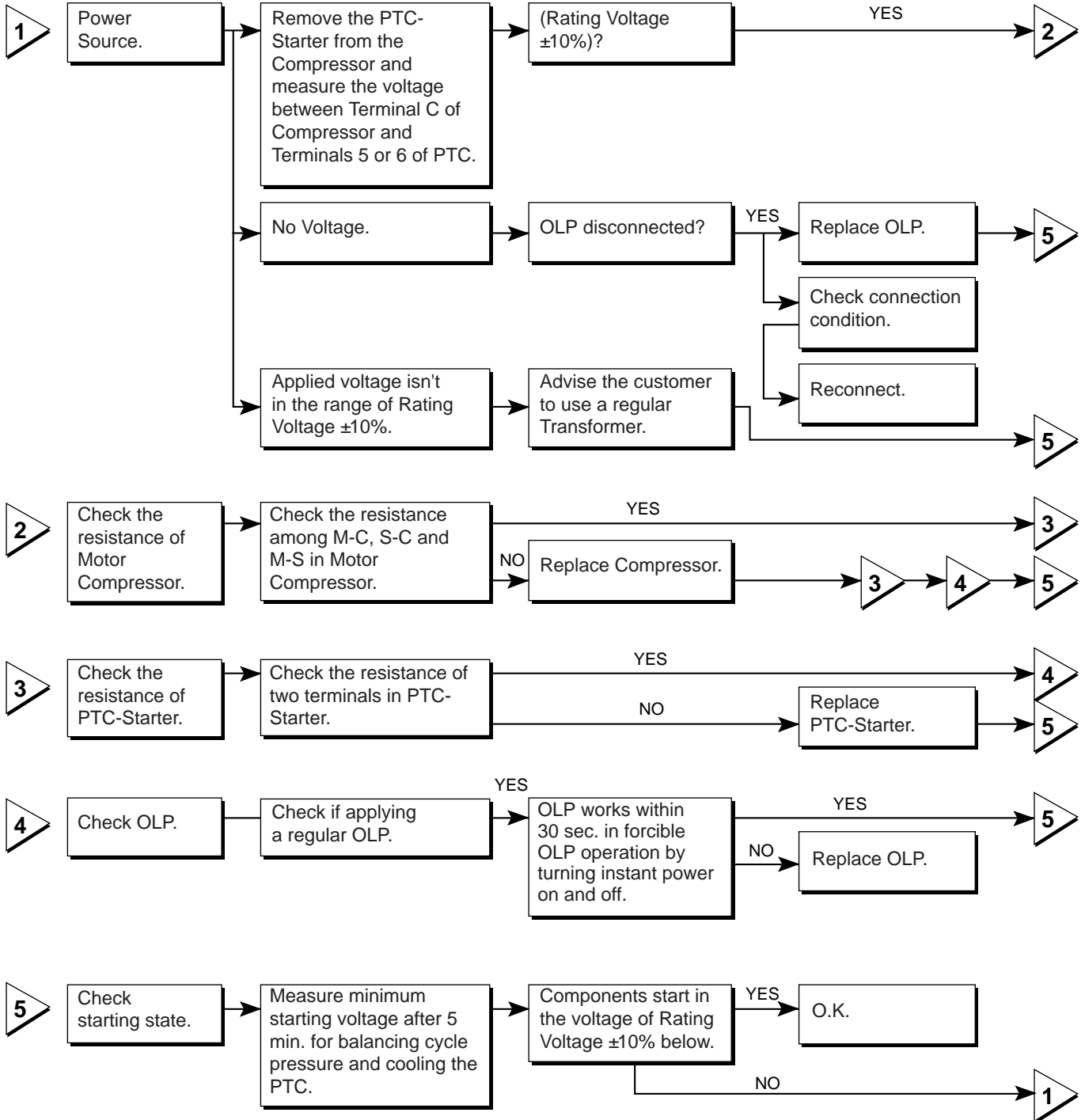

## 2 PTC AND OLP

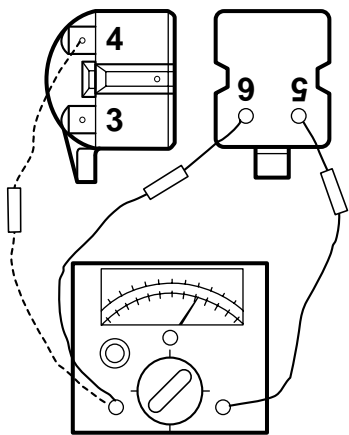
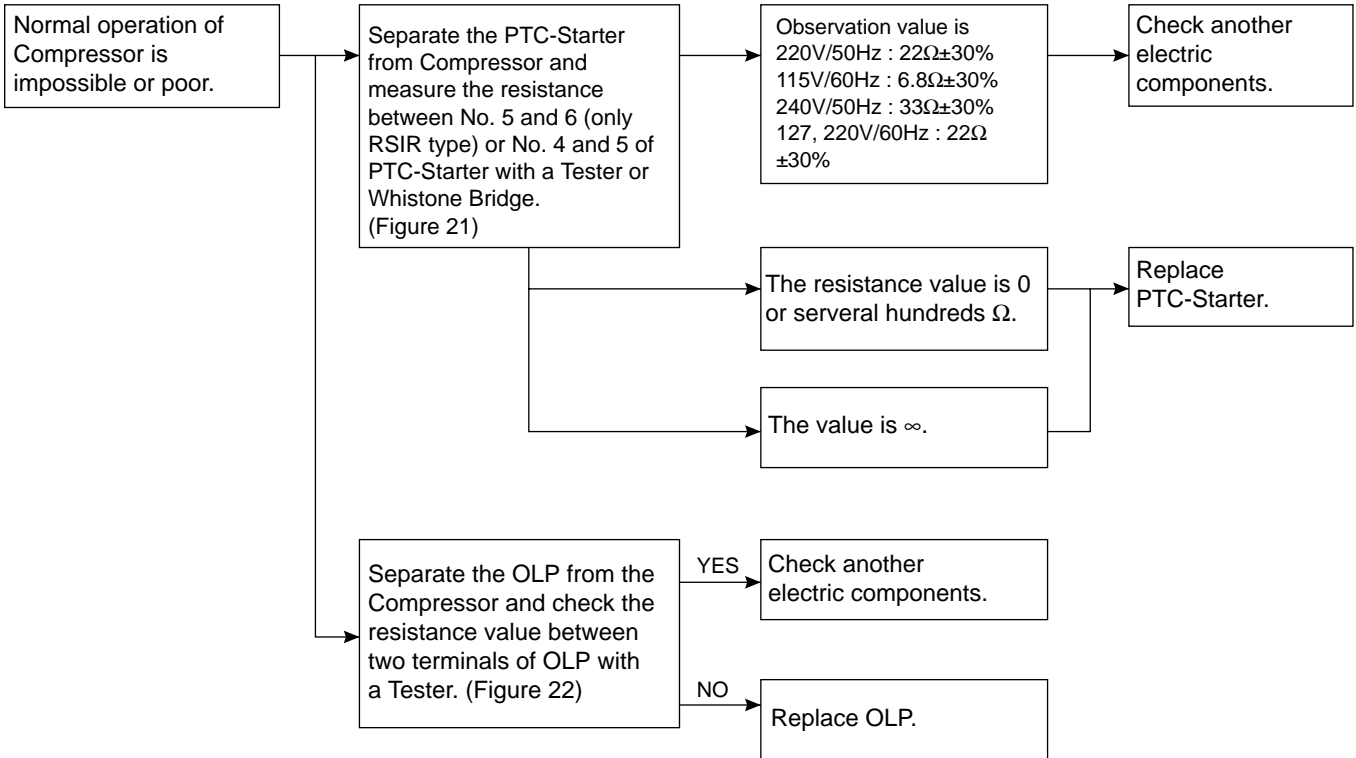

Figure 21

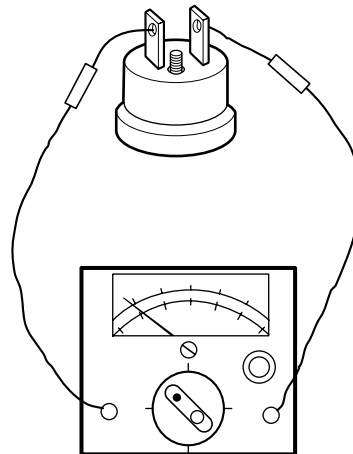
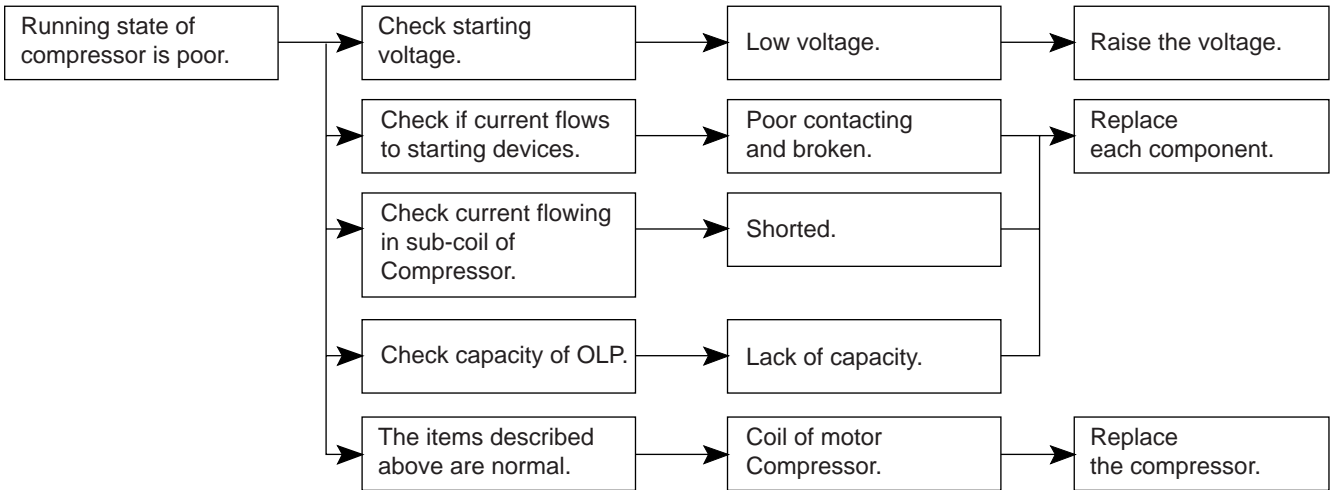
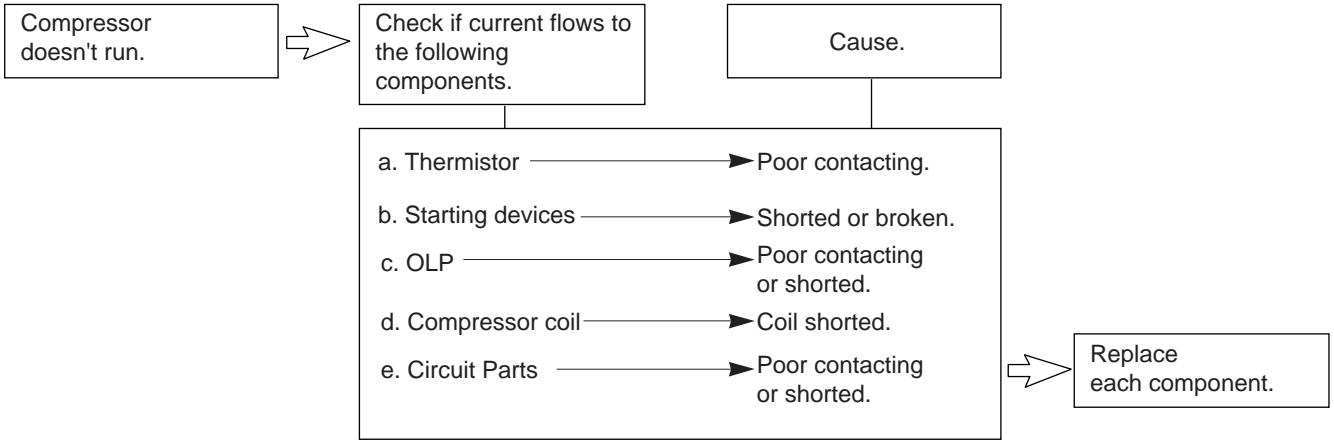

Figure 22

### 3 OTHER ELECTRIC COMPONENTS

#### ▼ No Cooling.



#### ▼ Cooling ability is poor

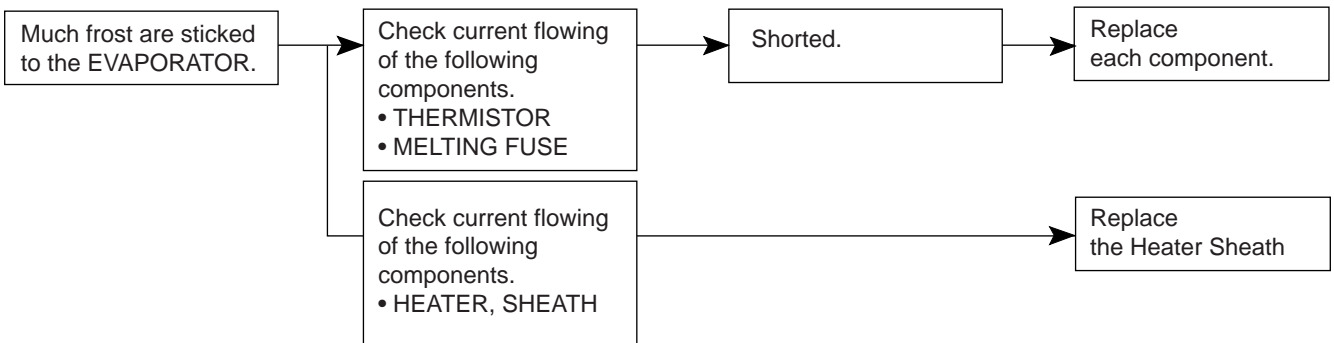
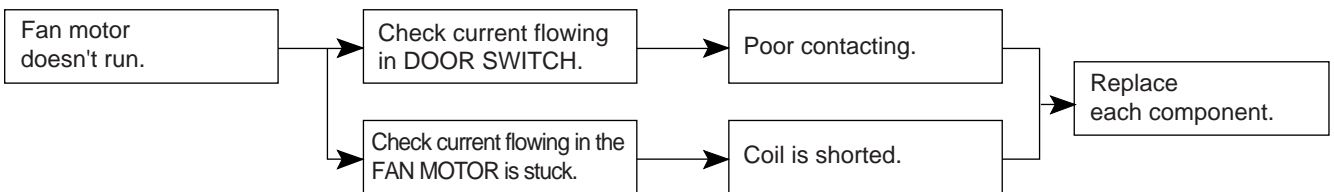

## 4 SERVICE DIAGNOSIS CHART

COMPLAINT	POINTS TO BE CHECKED	REMEDY
Cooling is impossible.	<ul style="list-style-type: none"> <li>• Is the power cord unplugged from the outlet?</li> <li>• Check if the power switch is set to OFF.</li> <li>• Check if the fuse of power switch is shorted.</li> <li>• Measure the voltage of power outlet.</li> </ul>	<ul style="list-style-type: none"> <li>• Plug in to the outlet.</li> <li>• Set the switch to ON.</li> <li>• Replace a regular fuse.</li> <li>• If voltage is low, wire newly.</li> </ul>
Cooling ability is poor.	<ul style="list-style-type: none"> <li>• Check if the set is placed close to wall.</li> <li>• Check if the set is placed close to stove, gas cooker and direct rays.</li> <li>• Is the ambient temperature high or the room door closed?</li> <li>• Check if put in is hot.</li> <li>• Did you open the door of the set too often or check if the door is closed up?</li> <li>• Check if the Damper Control is set to cold-position.</li> </ul>	<ul style="list-style-type: none"> <li>• Place the set with the space of about 10cm.</li> <li>• Place the set apart from these heat appliances.</li> <li>• Make the ambient temperature below.</li> <li>• Put in foods after cooled down.</li> <li>• Don't open the door too often and close it firmly.</li> <li>• Set the control to mid-position.</li> </ul>
Foods in the Refrigerator are frozen.	<ul style="list-style-type: none"> <li>• Is foods placed in cooling air outlet?</li> <li>• Check if the control is set to cold-position.</li> <li>• Is the ambient temperature below 5°C?</li> </ul>	<ul style="list-style-type: none"> <li>• Place foods in high temperature section. (Front Part)</li> <li>• Set the control to mid-position.</li> <li>• Set the control to warm-position.</li> </ul>
Dew or ice forms in the chamber of the set.	<ul style="list-style-type: none"> <li>• Is liquid food stored?</li> <li>• Check if put in is hot.</li> <li>• Did you open the door of the set too often or check if the door is closed.</li> </ul>	<ul style="list-style-type: none"> <li>• Seal up liquid foods with wrap.</li> <li>• Put in foods after cooled down.</li> <li>• Don't open the door too often and close it firmly.</li> </ul>
Dew forms in the Exterior Case.	<ul style="list-style-type: none"> <li>• Check if ambient temperature and humidity of surrounding air are high.</li> <li>• Is something in the door holding it open?</li> </ul>	<ul style="list-style-type: none"> <li>• Wipe dew with a dry cloth. This occurrence is solved naturally in low temperature and humidity.</li> <li>• Rearrange items to close door.</li> </ul>
Abnormal noise generates.	<ul style="list-style-type: none"> <li>• Are the set positioned in a firm and even place?</li> <li>• Are any unnecessary objects set in the back side of the set?</li> <li>• Check if the Tray Drip is not firmly fixed.</li> <li>• Check if the cover of mechanical room in below and front side is taken out.</li> </ul>	<ul style="list-style-type: none"> <li>• Adjust the adjust screw and position in the firm place.</li> <li>• Remove the objects.</li> <li>• Fix it firmly on the original position.</li> <li>• Place the cover at the original position.</li> </ul>
To close the door is not handy.	<ul style="list-style-type: none"> <li>• Check if the door packing is has something spilled on it.</li> <li>• Is the set positioned in a firm and even place?</li> <li>• Is the refrigerator overloaded?</li> </ul>	<ul style="list-style-type: none"> <li>• Clean the door packing.</li> <li>• Position in the firm place and adjust the adjust screw.</li> <li>• Keep foods not to reach the door.</li> </ul>
Ice and foods smell unpleasant.	<ul style="list-style-type: none"> <li>• Check if the inside of the set is dirty.</li> <li>• Did you keep aromatic foods without wrapping?</li> <li>• It smells of plastic.</li> </ul>	<ul style="list-style-type: none"> <li>• Clean the inside of the set.</li> <li>• Wrap aromatic foods.</li> <li>• The new products smells of plastic, but it is eliminated after 1-2 weeks.</li> </ul>

- In addition to the items described left, refer to the followings to solve the complaint.

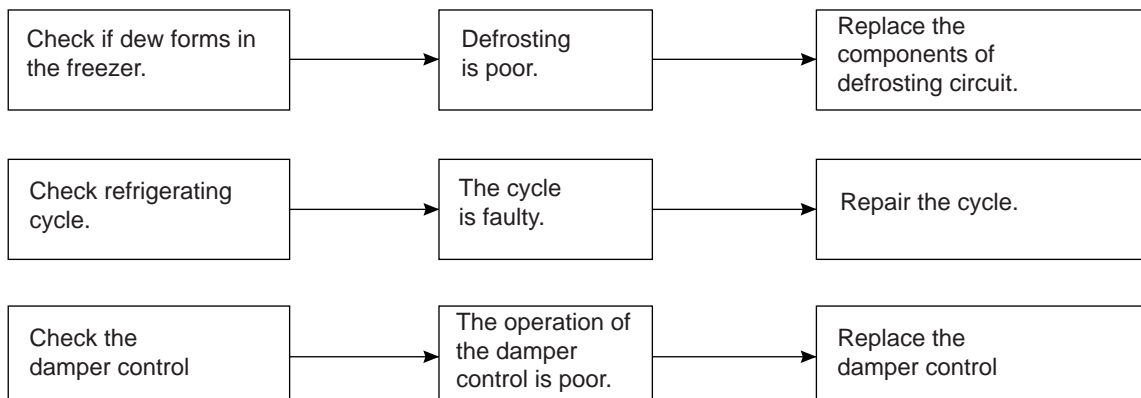

## 5 REFRIGERATING CYCLE

### ▼ Troubleshooting Chart

CAUSE		STATE OF THE SET	STATE OF THE EVAPORATOR	TEMPERATURE OF THE COMPRESSOR	REMARKS
LEAKAGE	PARTIAL LEAKAGE	Freezer room and refrigerator don't cool normally.	Low flowing sound of refrigerant is heard and frost forms in inlet only	A little high more than ambient temperature.	<ul style="list-style-type: none"> <li>A little refrigerant discharges.</li> <li>Normal cooling is possible when injecting of refrigerant the regular amount.</li> </ul>
	WHOLE LEAKAGE	Freezer and refrigerator don't cool normally.	Flowing sound of refrigerant is not heard and frost isn't formed.	Equal to ambient temperature.	<ul style="list-style-type: none"> <li>No discharging of refrigerant.</li> <li>Normal cooling is possible when injecting of refrigerant the regular amount.</li> </ul>
CLOGGED BY DUST	PARTIAL CLOG	Freeze room and refrigerator don't cool normally.	Flowing sound of refrigerant is heard and frost forms in inlet only.	A little high more than ambient temperature.	<ul style="list-style-type: none"> <li>Normal discharging of refrigerant.</li> <li>The capillary tube is faulty.</li> </ul>
	WHOLE CLOG	Freezer and refrigerator don't cool.	Flowing sound of refrigerant is not heard and frost isn't formed.	Equal to ambient temperature.	<ul style="list-style-type: none"> <li>Normal discharging of Refrigerant.</li> </ul>
MOISTURE CLOG		Cooling operation stops periodically.	Flowing sound of refrigerant is not heard and frost melts.	Lower than ambient temperature	<ul style="list-style-type: none"> <li>Cooling operation restarts when heating the inlet of capillary tube.</li> </ul>
DEFECTIVE COMPRESSION	COMP-RESSION	Freezer and refrigerator don't cool.	Low flowing sound of refrigerant is heard and frost forms in inlet only.	A little higher than ambient temperature.	<ul style="list-style-type: none"> <li>The pressure of high pressure part in compressor is low.</li> </ul>
	NO COMP-RESSION	No compressing operation.	Flowing sound of refrigerant is not heard and no frost.	Equal to ambient temperature.	<ul style="list-style-type: none"> <li>No pressure of high pressure part in the compressor.</li> </ul>

### ▼ Leakage Detection

- Observe discharging point of refrigerant which may be in the oil discharging part in the compressor and hole of evaporator.

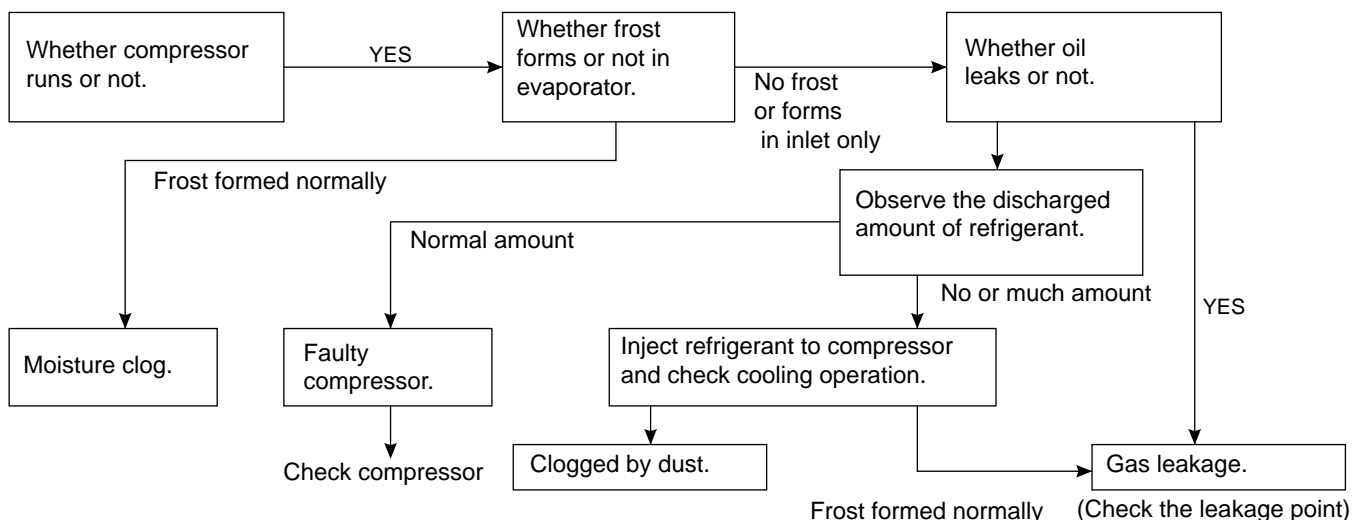

▼ General Control of Refrigerating Cycle

NO.	ITEMS	CONTENTS AND SPECIFICATIONS	REMARKS
1	WELDING ROD	(1) H 30 <ul style="list-style-type: none"> <li>• Chemical Ingredients Ag: 30%, Cu: 27%, Zn: 23%, Cd: 20%</li> <li>• Brazing Temperature: 710~840°C</li> </ul> (2) Bcup-2 <ul style="list-style-type: none"> <li>• Chemical Ingredients Cu: About 93%</li> <li>P: 6.8~7.5%</li> <li>The rest: within 0.2%</li> <li>• Brazing Temperature: 735~840°C</li> </ul>	<ul style="list-style-type: none"> <li>• Recommend H34 containing 34% Ag in the Service Center.</li> </ul>
2	FLUX	<ul style="list-style-type: none"> <li>• Ingredients and how to make Borax 30%</li> <li>Borax 35%</li> <li>Fluoridation kalium: 35%</li> <li>Water: 4%</li> <li>Mix the above ingredients and boil until they are transformed into liquid.</li> </ul>	<ul style="list-style-type: none"> <li>• Make amount for only one day. Holding period: 1 day</li> <li>• Close the cover of container to prevent dust putting in the FLUX.</li> <li>• Keep it in a stainless steel container.</li> </ul>
3	DRIER ASSEMBLY	(1) Assemble the drier within 30min. after unpacking. (2) Keep the unpacked drier at the temperature of 80~100°C.	<ul style="list-style-type: none"> <li>• Don't keep the drier outdoors because humidity damages to it.</li> </ul>
4	VACUUM	(1) When measuring with pirant Vacuum gauge the charging M/C, vacuum degree is within 1 Torr. (2) If the vacuum degree of the cycle inside is 10 Torr. below for low pressure and 20 Torr. for high pressure, it says no vacuum leakage state. (3) Vacuum degree of vacuum pump must be 0.05 Torr. below after 5 min. (4) Vacuum degree must be same to the value described item (2) above for more than 20 min.	<ul style="list-style-type: none"> <li>• Apply M/C Vacuum Gauge without fail.</li> <li>• Perform vacuum operation until a proper vacuum degree is built up.</li> <li>• If a proper vacuum degree isn't built up, check the leakage from the Cycle Pipe line part and Quick Coupler Connecting part.</li> </ul>
5	DRY AND AIR NITROGEN GAS	(1) The pressure of dry air must be more than 12~16kg/cm <sup>2</sup> (2) Temperature must be between -20~and 70°C. (3) Keep the pressure at 12~6kg/cm <sup>2</sup> also when substituting dry air for Nitrogen Gas.	
6	NIPPLE AND COUPLER	(1) Check if gas leaks with soapy water. (2) Replace Quick Coupler in case of leakage.	<ul style="list-style-type: none"> <li>• Check if gas leaks from joint of the Coupler.</li> </ul>
7	PIPE	<ul style="list-style-type: none"> <li>• Put all Joint Pipes in a clean box and cover tightly with the lid so that dust or humidity is not inserted.</li> </ul>	



# MICOM FUNCTION & PCB CIRCUIT EXPLANATION

This description is made for GR-349 & 389. Please refer to overall PCB circuits for other models.

## 1 FUNCTION EXPOSITION

### 1) FUNCTION

- (1) The refrigerator starts from optimum condition when electric power is first on. The operation condition changes Mid → Mid/Max → Max → Min → Min/Mid → Mid whenever you press the FREEZE TEMP button.
- (2) It returns to Mid conditions if power off and on again.

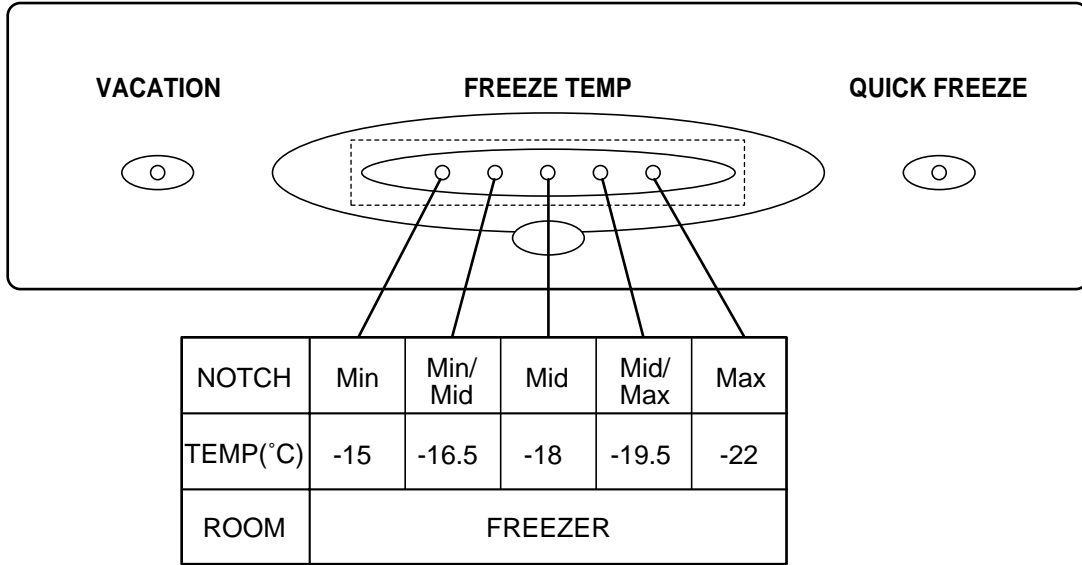

### 2) QUICK FREEZER

- (1) This raises the freezing speed by operating the compressor continuously. Press the QUICK FREEZE button and the QUICK FREEZE LED is displayed. Then after 3 hours' successive operation of compressor operation, the QUICK FREEZING function will be released.
- (2) Defrosting during the QUICK FREEZING operates as follows!  
When the QUICK FREEZING time is below 90 minutes, defrost and then operate the QUICK FREEZING for the remaining time. When the QUICK FREEZING time is over 90 minutes, defrost and then operate the QUICK FREEZING for 2 hours
- (3) If QUICK FREEZE button is pressed during defrosting, the QUICK FREEZE LED is lit. The QUICK FREEZING operates for 3 hours after 7 minutes from the end of defrosting.
- (4) If VACATION button is pressed during the QUICK FREEZING, the QUICK FREEZING LED function is released.
- (5) If power is interrupted during QUICK FREEZING, the QUICK FREEZING function is released.

### 3) VACATION FUNCTION

- (1) Function for Energy Saving. Press the VACATION button, and the VACATION LED is displayed and this function is operated.
- (2) Freezer Compartment is not kept by compressor at the notch displayed but at -13°C± differential.
- (3) Defrosting and fan control are same as normal operation.
- (4) If QUICK FREEZE button is pressed during the VACATION FUNCTION, VACATION FUNCTION is released.
- (5) If power is interrupted during VACATION FUNCTION, the VACATION FUNCTION is released.

#### 4) DOOR OPENING ALARM

- (1) When the REFRIGERATOR DOOR is opened and isn't closed after 1 minute, the BUZZER sounds.
- (2) At first, BUZZER sounds three times at each intervals of 0.5 second, then makes a 0.5 second ON/OFF alarm three times at intervals of 30 seconds.
- (3) If the REFRIGERATOR door closed during ALARM, the ALARM cancels.

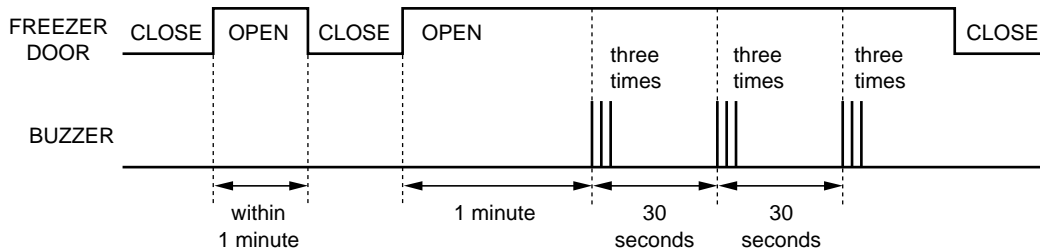

#### 5) DISPLAY BUTTON RING

- (1) If display function button (FREEZE TEMP, QUICK FREEZE, VACATION) of the front of the TOP COVER is pushed, BUZZER rings with DING~ DONG~ (See the BUZZER OPERATION CHECK p.22)

#### 6) DEFROSTING

- (1) If the accumulated time for the operation of the COMPRESSOR is 7 hours, the DEFROSTING HEATER is started.
- (2) The first defrosting is performed 4 hours (compressor ON) later since the power is on.
- (3) If DEFROST SENSOR is over 7 °C during DEFROSTING, end the operation of DEFROSTING with DEFROSTING HEATER paused, and after 7 minutes, the operation for the freezing is started.  
If DEFROST SENSOR is not reach to 7 °C after 2 hours' operation of the defrosting heater, it indicates a defrosting trouble. (See the TROUBLE REPRESENTING FUNCTION)
- (4) If DEFROST SENSOR is short or open, defrosting is not performed.

#### 7) ORDERLY OPERATION OF ELECTRIC PARTS

To avoid NOISE and DAMAGE, the items containing an electric parts such as compressor, DEFROSTING HEATER, and FAN MOTOR operate in order as follows.

	OPERATION STATE	OPERATION ORDER				
<b>WHEN PLUGGED AT FIRST</b>	WHEN DEFROST SENSOR TEMPERATURE IS OVER 7°C. (WHEN PURCHASING OR MOVING)	<b>POWER ON</b>	→ after 0.5 sec.	<b>COMP ON</b>	→ after 0.5 sec.	<b>FAN ON</b>
	WHEN DEFROST SENSOR TEMPERATURE IS BELOW 7°C. (WHEN POWER FAILURE OR SERVICING)	<b>POWER ON</b>	→ after 0.5 sec.	<b>DEFROSTING HEATER ON</b>	→ after 10 sec.	<b>DEFROSTING HEATER ON</b>
			→ after 0.5 sec.	<b>COMP ON</b>	→ after 0.5 sec.	<b>FAN ON</b>
	WHEN RETURNING TO NORMAL STATE FROM TEST MODE	<b>All Elec. Parts OFF</b>	→ after 7 min .	<b>COMP ON</b>	→ after 0.5 sec.	<b>FAN ON</b>

## 8) SELF-TEST

- (1) Function to make service easy in case of occurring a trouble in the product.
- (2) When a trouble occurs, the button is pushed, but the function doesn't operate.
- (3) If a problem releases during the representation of trouble, a refrigerator performs the normal function (RESET).
- (4) Error codes are displayed by FREEZE TEMP LEDs on TOP COVER. If ERROR occurs, the other LEDs except ERROR CODE LEDs are all off.

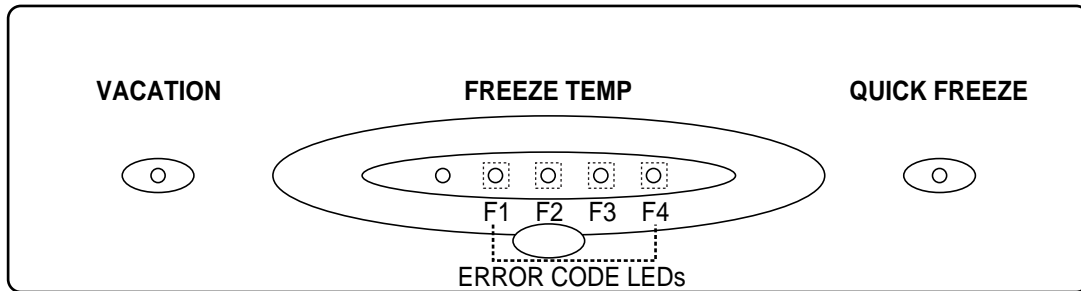

O : OPERATE NORMAL ○ : ON  
● : OFF

NO.	ITEMS	ERROR CODE LEDs F1 F2 F3 F4	DESCRIPTION	THIS IS WHAT HAPPENS!		
				COMP	FAN	DEFROST HEATER
1	FREEZER SENSOR abnormal	○ ● ● ●	FREEZER SENSOR open or short.	15 minutes On/ 15 minutes Off	○	○
2	DEFROST SENSOR abnormal	● ● ○ ●	DEFROST SENSOR open or short.	○	○	No defrosting
3	DEFROSTING FUNCTION is abnormal	○ ○ ○ ○	DEFROST HEATER, TEMP. FUSE open or disconnection (Displayed after at least 4 hours from the trouble's occurring.)	○	○	○
4	RT-SENSOR abnormal	NOTE 1)	Room Temperature SENSOR open or short	○	○	○

\* NOTE 1) Press the QUICK FREEZE and FREEZE TEMP buttons together in normal operation, get this result.

RT-SENSOR □ If normal, LEDs on the TOP COVER is all on.  
 If abnormal, LEDs are all on except VACATION LED.

## 9) FUNCTION TEST

- (1) Function to check the testing function of PCB and refrigerator and to find where the trouble.
- (2) The test switch is on the MAIN PCB of refrigerator.  
TEST FUNCTION is released and RESET after MAX. 2 hours, regardless of TEST MODE.
- (3) If the buttons on TOP COVER is pushed during TEST MODE, Function is not operated and only BUZZER ring with DING~ DONG~
- (4) After the end of TEST MODE, pull out the power cord and plug it in again (RESET).
- (5) If a ERROR occurs during the TEST MODE, TEST FUNCTION is released and DISPLAY LEDS represent ERROR CODE.
- (6) If the TEST swithch is pushed during ERROR CODE, TEST FUNCTION is not operated.

MODE	OPERATION	CONTENTS	REMARKS
TEST 1	Press TEST button once.	1. COMPRESSOR OPERATES CONTINUOUSLY. 2. FAN OPERATES CONTINUOUSLY. 3. DEFROSTING HEATER OFF 4. ALL DISPLAY LEDS ON.	
TEST 2	Press TEST button once in the state of TEST MODE 1.	1. COMPRESSOR OFF. 2. FAN OFF. 3. DEFROST HEATER ON. 4. ALL THE DISPLAY LEDS OFF EXCEPT QUICK FREEZE AND VACATION LEDS.	If DEFROST HEATER is over 7°C, it returns to the NORMAL STATE.
NORMAL STATE	Press TEST button once in the state of TEST MODE 2.	Return to the initial condition. (RESET)	Compressor starts after 7 minutes.

- **LED Check Function** : Press the QUICK FREEZE and FREEZE TEMP buttons at the same time. After 1 sec., all the LEDs of the DISPLAY are ON simultaneously. Release the BUTTON to return to the previous condition.

## 2 FUNCTION DESCRIPTION

### 1) ELECTRIC CIRCUITS

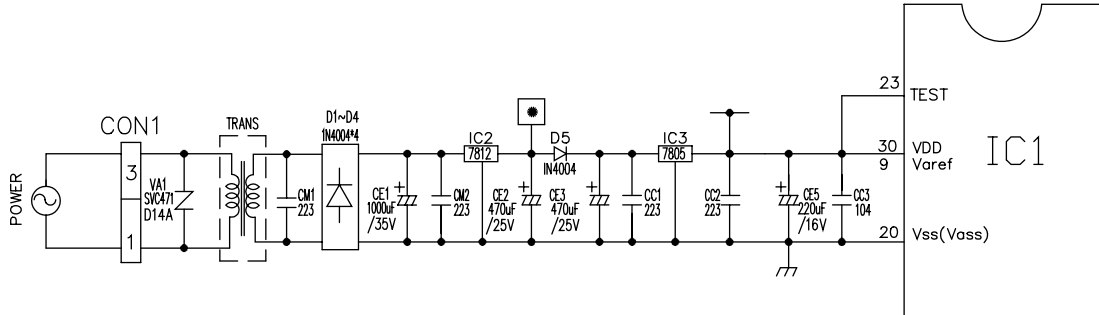

TRANS secondary side is composed of electric power circuits for RELAY driving electricity (12Vdc) and for supplying electricity to MICOM and IC (5Vdc). The voltage in each part is as follows.

PARTS	both ends of VA1	both ends of CM1	both ends of CM2	both ends of CE2	both ends of CC2
VOLTAGE	230Vac	14Vac	17Vdc	12Vdc	5Vdc

VA1 is the part to protect over voltage and noise. When more than 385V is applied, the thermal-fuse (130°C cut-off, local option) in a first part of TRANS is cut so that the elements in the secondary side of TRANS are protected.

### 2) OSCILLATION CIRCUIT

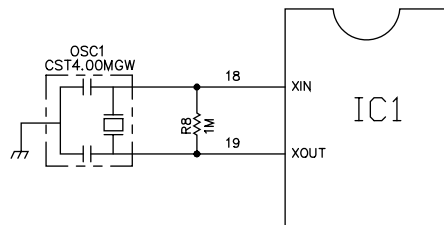

CIRCUIT for CLOCK which motivates the internal local element of IC1 to transmit and receive information and BASIC TIME for calculating time. Use a proper form for OSC 1. In the event that SPECIFICATION is changed, the calculated time in IC1 is changed or IC1 isn't able to operate.

### 3) RESET CIRCUIT

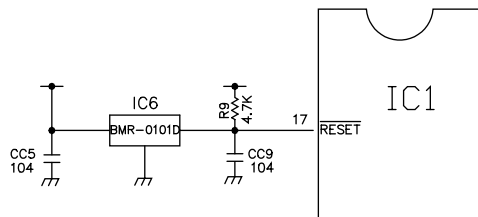

All the internal parts of MICOM (IC1) return to the initial condition at power ON in MICOM after temporary power failure. As a result, all the functions operate according to the early condition. At the early period of power ON the LOW voltage is applied in the RESET terminal of MICOM for the fixed time. The RESET terminal is 5 V during the general operation.

#### 4) LOAD/BUZZER OPERATION, DOOR OPENING SENSING CIRCUIT

##### (1) LOAD OPERATION CHECK

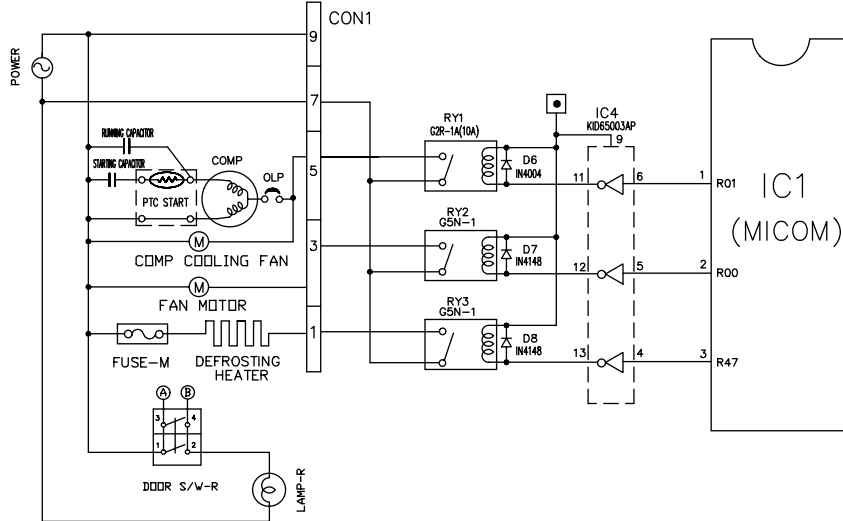

KIND OF LOAD		COMPRESSOR, COMPRESSOR COOLING FAN	FAN MOTOR	DEFROSTING HEATER
MEASURING POINT (IC5)		No.13	No.14	No.15
STATE	ON	below 1V		
	OFF	12V		

If the DOOR-R is opened during FAN MOTOR is operated, FAN MOTOR is stopped immediately.

The (A), (B) of DOOR S/W-R is connected DOOR OPEN DETECTION CIRCUIT as follow.

If the DOOR-R is opened or closed, then the DOOR S/W-R is ON/OFF, and the LAMP-R is ON/OFF, and at the same time, S/W of the (A), (B) of DOOR S/W-R for detection of DOOR-R open is ON/OFF.

##### (2) DOOR OPENING PERCEPTION CHECK

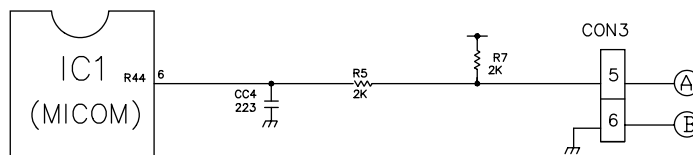

\*NOTICE: If you change DOOR S/W-R, you must use a component of the right PART NUMBER. There is a similar type DOOR S/W-R of NOT MICOM MODEL, and its logic of the (A), (B) of DOOR S/W-R is reversed.

MEASURING POINT	NO.6 OF IC 1 (MICOM)
REFRIGERATOR DOOR	
CLOSE	5V(S/W of (A), (B) is OFF state)
OPEN	0V(S/W of (A), (B) is ON state)

Even though LAMP-R is operated a normal ON/OFF according to DOOR S/W-R, the MICOM can't detect a DOOR-R opened or closed of lead wire of the (A), (B) is abnormal or S/W of the (A), (B) of DOOR S/W-R is abnormal.

When DOOR-R open isn't detected : Even though DOOR-R is opened, FAN MOTOR couldn't stop.

When DOOR-R close isn't detected : Even though DOOR-R is closed, BUZZER sounds a DOOR OPEN ALARM. check a lead wire of the (A), (B) and DOOR S/W-R.

(3) BUZZER OPERATION CHECK

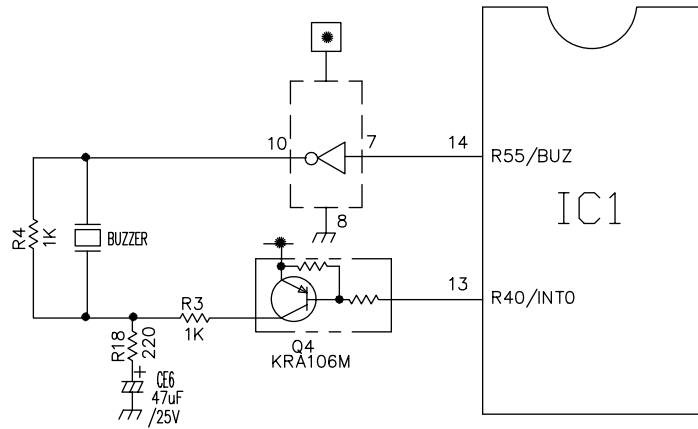

MEASURING POINT \ CONDITIONS	DISPLAY FUNCTION BUTTON RING (DING~ DONG~)	DOOR OPEN ALARM (SCREECHING)	OFF
IC1 (No.14 Pin)			0V
IC1 (No.13 Pin)			0V

## 5) TEMP SENSOR CIRCUITS

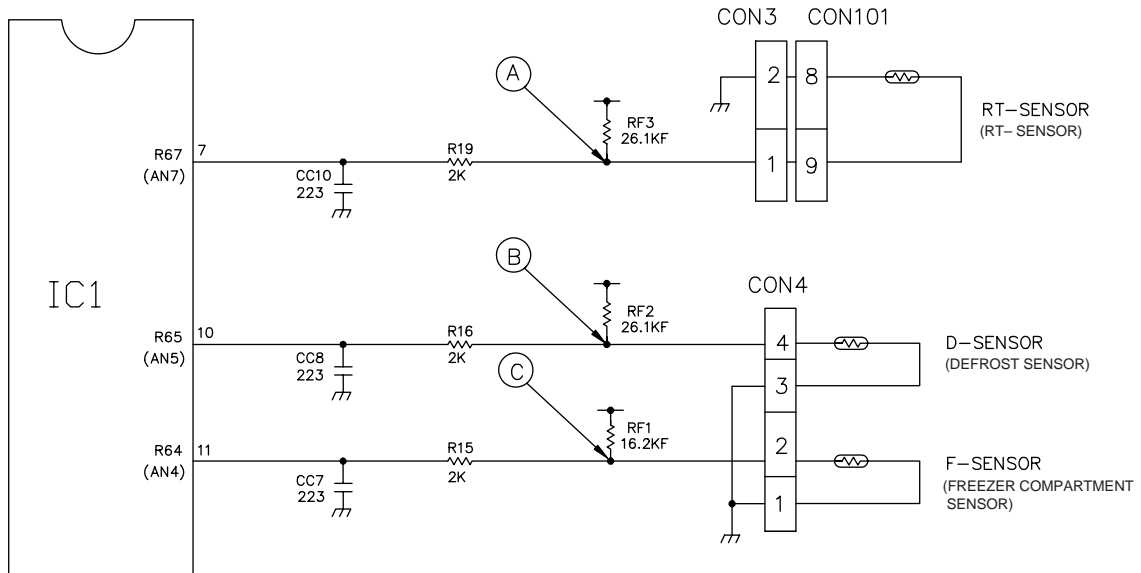

The above circuit reads the surrounding temperature, DEFROSTING temperature, and FREEZER ROOM temperature into MICOM (IC1). OPEN or SHORT state of each SENSOR is as follows.

SENSOR	CHECK POINT	NORMAL (-30 °C~50 °C)	SHORT	OPEN
ROOM TEMPERATURE SENSOR	POINT Ⓐ Voltage	0.5 V ~ 4.5 V	0 V	5 V
DEFROST SENSOR	POINT Ⓑ Voltage			
FREEZER SENSOR	POINT Ⓒ Voltage			

## 6) SWITCH INPUT CIRCUIT

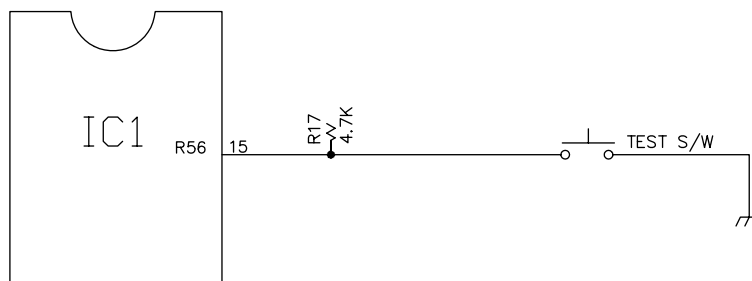

The following circuit is a test switch input circuit for checking the refrigerator.



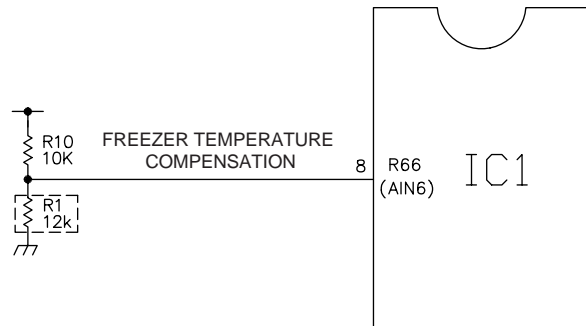

## 7) TEMPERATURE COMPENSATION



FREEZER ROOM		REMARKS
RESISTANCE VALUES(R1)	TEMPERATURE COMPENSATION	
180 kΩ	+ 5.0°C	COMPENSATE WARMLY 
56 kΩ	+4.0°C	
33 kΩ	+3.0°C	
18 kΩ	+2.0°C	
12 kΩ	+1.0°C	
10 kΩ	0°C	STANDARD
8.2 kΩ	-1.0°C	 COMPENSATE COOLLY
5.6 kΩ	-2.0°C	
3.3 kΩ	-3.0°C	
2 kΩ	-4.0°C	
470 Ω	-5.0°C	

- TEMPERATURE COMPENSATION TABLE by adjusting resistance values. (the temperature difference compared to the present temp.)

eg) If the compensation resistance of freezer compartment is changed from 10K (present resistance) to 18K (revised resistance), the temperature of freezer compartment goes up by +2°C.

• TEMPERATURE COMPENSATION OF FREEZER ROOM

	Revised resistance	470 Ω	2 kΩ	3.3 kΩ	5.6 kΩ	8.2 kΩ	10 kΩ	12 kΩ	18 kΩ	33kΩ	56 kΩ	180 kΩ
	Present resistance											
FREEZER ROOM (R1)	470 Ω	NOT COMPENSATE	1 °C↑	2 °C↑	3 °C↑	4 °C↑	5 °C↑	6 °C↑	7 °C↑	8 °C↑	9 °C↑	10 °C↑
	2k Ω	1 °C↓	NOT COMPENSATE	1 °C↑	2 °C↑	3 °C↑	4 °C↑	5 °C↑	6 °C↑	7 °C↑	8 °C↑	9 °C↑
	3.3 kΩ	2 °C↓	1 °C↓	NOT COMPENSATE	1 °C↑	2 °C↑	3 °C↑	4 °C↑	5 °C↑	6 °C↑	7 °C↑	8 °C↑
	5.6 kΩ	3 °C↓	2 °C↓	1 °C↓	NOT COMPENSATE	1 °C↑	2 °C↑	3 °C↑	4 °C↑	5 °C↑	6 °C↑	7 °C↑
	8.2 kΩ	4 °C↓	3 °C↓	2 °C↓	1 °C↓	NOT COMPENSATE	1 °C↑	2 °C↑	3 °C↑	4 °C↑	5 °C↑	6 °C↑
	10 kΩ	5 °C↓	4 °C↓	3 °C↓	2 °C↓	1 °C↓	NOT COMPENSATE	1 °C↑	2 °C↑	3 °C↑	4 °C↑	5 °C↑
	12 kΩ	6 °C↓	5 °C↓	4 °C↓	3 °C↓	2 °C↓	1 °C↓	NOT COMPENSATE	1 °C↑	2 °C↑	3 °C↑	4 °C↑
	18 kΩ	7 °C↓	6 °C↓	5 °C↓	4 °C↓	3 °C↓	2 °C↓	1 °C↓	NOT COMPENSATE	1 °C↑	2 °C↑	3 °C↑
	33 kΩ	8 °C↓	7 °C↓	6 °C↓	5 °C↓	4 °C↓	3 °C↓	2 °C↓	1 °C↓	NOT COMPENSATE	1 °C↑	2 °C↑
	56 kΩ	9 °C↓	8 °C↓	7 °C↓	6 °C↓	5 °C↓	4 °C↓	3 °C↓	2 °C↓	1 °C↓	NOT COMPENSATE	1 °C↑
	180 kΩ	10 °C↓	9 °C↓	8 °C↓	7 °C↓	6 °C↓	5 °C↓	4 °C↓	3 °C↓	2 °C↓	1 °C↓	NOT COMPENSATE

- This circuit is aimed to input the necessary temperature compensation values into the MICOM in order to adjust the freezer temperature which is different in each model.

## 8) LIGHTING CIRCUITS OF KEY BUTTON INPUT AND DISPLAY PARTS

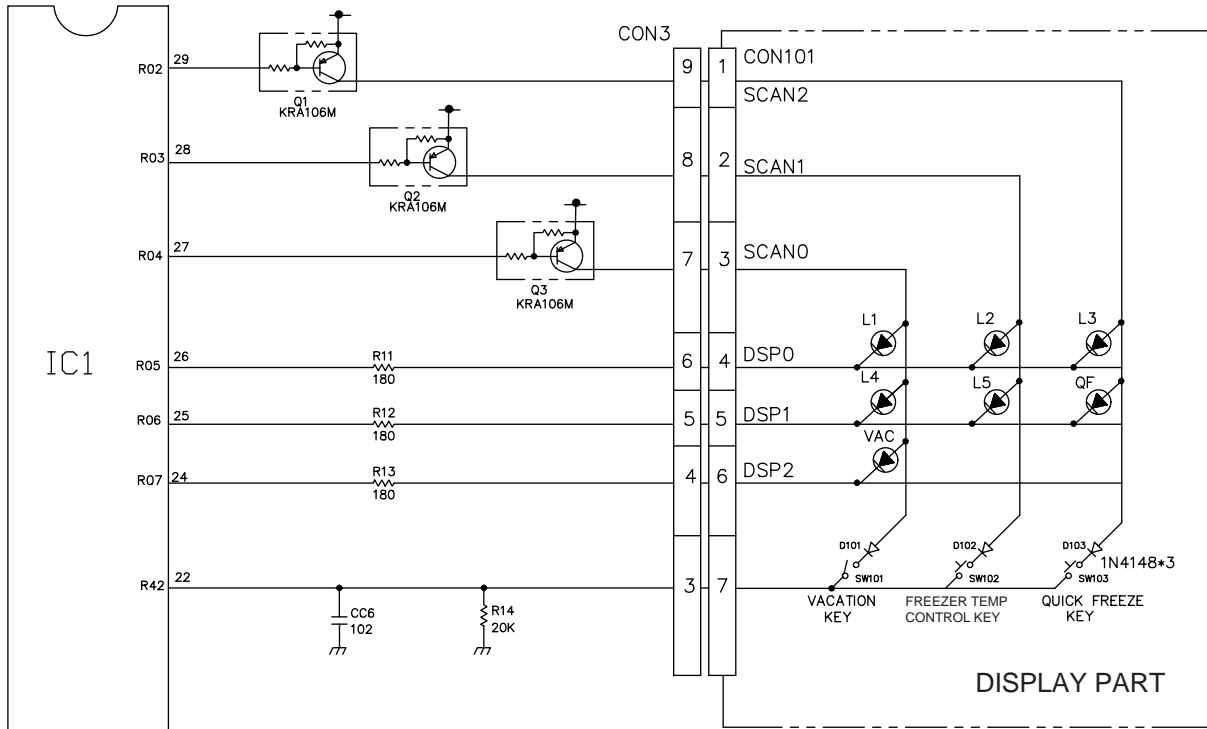

The above circuit is to judge the operation conditions of function key and to light each function indicating LED. It is operated by SCAN method.

---

### 3. SENSOR RESISTANCE CHARACTERISTICS TABLE

MEASURED TEMPERATURE	RESISTANCE OF FREEZER SENSOR	RESISTANCE OF DEFROST SENSOR, ROOM TEMPERATURE SENSOR
-20°C	22.3kΩ	77kΩ
-15°C	16.9kΩ	60kΩ
-10°C	13.0kΩ	47.3kΩ
-5°C	10.1kΩ	38.4kΩ
0°C	7.8kΩ	30kΩ
+5°C	6.2kΩ	24.1kΩ
+10°C	4.9kΩ	19.5kΩ
+15°C	3.9kΩ	15.9kΩ
+20°C	3.1kΩ	13kΩ
+25°C	2.5kΩ	11kΩ
+30°C	2.0kΩ	8.9kΩ
+40°C	1.4kΩ	6.2kΩ
+50°C	0.8kΩ	4.3kΩ

- The tolerance of sensor resistance is  $\pm 5\%$ .
- Be sure to measure the sensor resistance after keeping the sensor more than 3 minutes at a measuring temperature. (It needs delay due to sensor speed.)
- Measure the resistances of SENSORS with a digital tester after disconnecting CON 4 of MAIN PWB ASSY.

## 4. MAIN PWB ASSEMBLY AND PARTS LIST

### 1) MAIN PWB ASSEMBLY

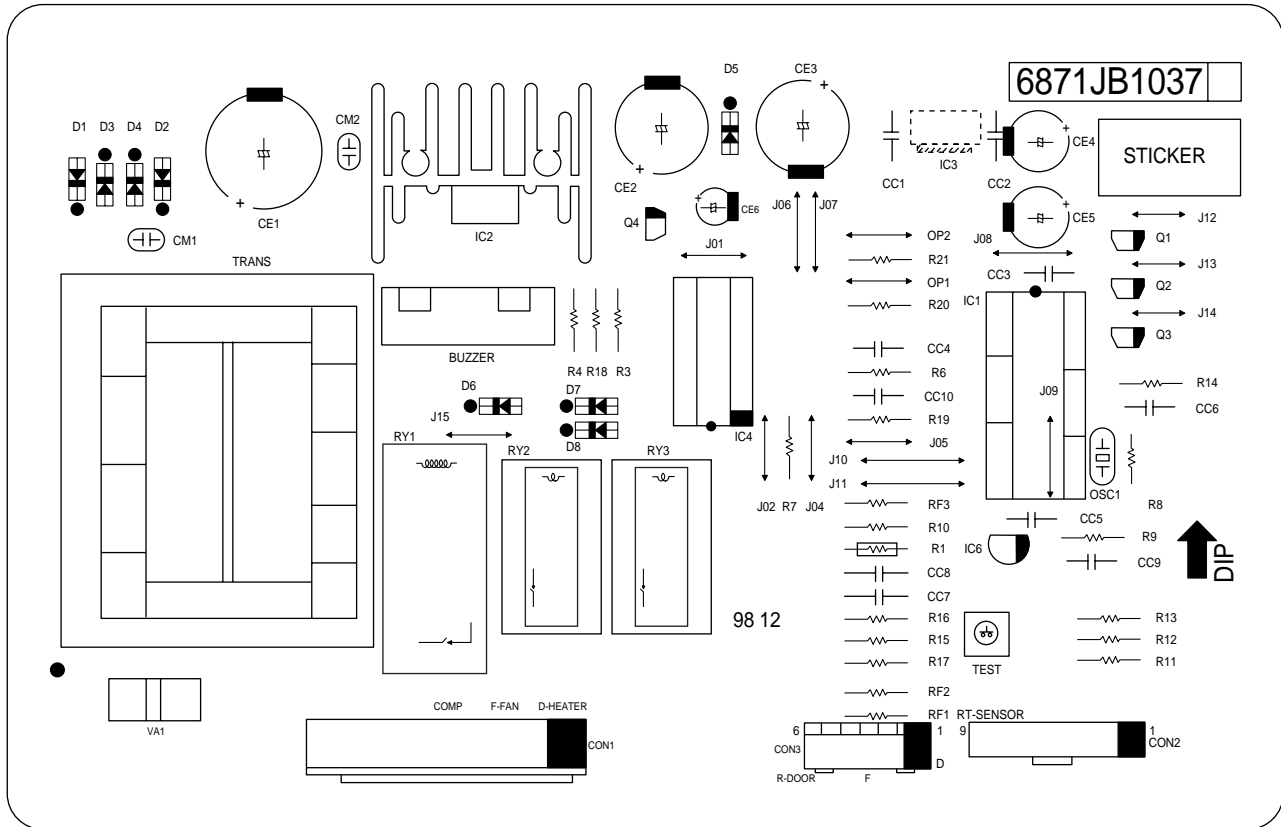

## 2) REPLACEMENT PARTS LIST

NO.	DWG. NO.	DESCRIPTION	SPEC'	QTY.	MAKER	REMARK
1	6870JB2024	PWB,MAIN	FR-1(DS-1107A)	1A	DOO SAN	t=1.6
2	6170JB2005	TRANS PCB	I: 240V, O: 14V	1A	K. T.C TAE SUNG	TRANS
3	6630JB8001D	WAFER	(1)202-11-05(9P-2458) (2)202-11-02(3P-2)	1	JAE EUN	CON1
4						
5	6630JB8004E		SMW250-06	1	YEON HO	CON3
6	6630JB8004H		SMW250-09	1		CON2
7						
8	01ZZJB2002A	MICOM CHIP	GMS81504	1		IC1 (=01ZZJB2002B)
9						
10						
11	01RH178120A 01KE781200M	REGULATOR	(1)BA17812T (2)KIA7812PI	1	ROHM KEC	IC2
12	01RH178120A 01KE781200M		(1)BA17812T (2)KIA7812PI	1	ROHM KEC	
13	01RH178050B 01KE780500Z	REGULATOR	(1)BA17805T (2)KIA7805PI	1	ROHM KEC	IC3
14	01KE704200A 01KD010100A		RESET IC	K1A7042P BMR-0101D	1	K.E.C KODENSHI
15	01KE650030B	DRIVE IC	KID65003AP	1	K.E.C	IC4
16	01T0721000A	PHOTO TR	TLP721	1	TOSHIBA	
17						
18						
19	J510-00018A 6920JB2002A 6920JB2005A 6920JB2003A	RELAY	G2R-1A VS-12MB JW1αFHN	1	OMRON TAKAMISAWA NAIS	RY1
20			G5N-1	2	OMRON	RY2,RY3
21	J570-00012A J570-00012B	RESONATOR	CST4.00MGW CST4.00MGW-TF01	1	MURATA	OSC1 (=6212A09002B)
22	J572-00001C (=6102A09075A)	VARIATOR	(1)INR14D471 (2)SVC471D-14A	1	IL JIN SAMHWA	VA1
23						
24	0DD400409AA	RECTIFIER DIODE	1N4004	6	(1)P.C (2)DELTA	D1~6
25	0DD400709AA		1N4007			
26	0DD414800AA	SWITCHING DIODE	1N4148	1	(1)P.C (2)ROHM	D7 D8
27	OCE2286J618	ELE' CAPACITOR	2200uF/35V		(1)SAM HWA (2)SAM YOUNG	CE1
28	OCE1081J618		1000uF/35V	1		
29	OCE1081H618		1000uF/25V	1		
30	OCE4771H618		470uF/25V	1		
31	OCE2271F638		220uF/16V	1		
32	OCE4761H638		47uF/25V	1		
33	028105K638		1uF/50V			
34	6908JB3002A	PIEZO BUZZER	BM-20K	1	BUJUN	BUZZ
35	0CQ2231N409	MYL' CAPACITOR	223/100V	2	SEIL	CM1,CM2
36	0CK1020H908	CER' CAPACITOR	102/25V	1	TAE YANG	CC6
37	0CK2230H908		223/25V	5		CC1,2,4,7,8
38	0CK1040H908		104/50V	3		CC3,5,9
39	ORD5602K609	R,CEMENT	56K 2W			
40	ORD2700H608	R,CARBON FILM	270J 1/2W		(1)C.Y (2)K-OHM (3)DONG HO (4)SUNG YO	
41	ORD1800H608		180J 1/4W	1		R11
42	ORD1800H608		180J 1/4W	1		R12
43	ORD1800H608		180J 1/4W	1		R13
44						
45						
46						

NO.	DWG. NO.	DESCRIPTION	SPEC'	QTY.	MAKER	REMARK
47	ORD1000G608	R,CARBON FILM	100J 1/4W		(1)C.Y (2)K-OHM (3)DONG HO (4)SUNG YO	
48	ORD2200G608		220J 1/4W	1		R18
49						
50	ORD2200G608		20KJ 1/4W			
51	ORD4700G608		470J 1/4W			
52	ORD6200G608		620J 1/4W			
53	ORD1001G608		1KJ 1/4W	2		R3,R4
54	ORD2001G608		2KJ 1/4W	2		R15,16
55				3		R19 R5,R7
56	ORD2201G608		20KJ 1/4W	1		R14
57						
58	ORD4701G608		4.7KJ 1/4W	4	R9,17,20,21	
59				1		
60	ORD1002G608		10KJ 1/4W		R10	
61	ORD1004G608		1MJ 1/4W	1	R8	
62	ORN1012G408	R,METAL FILM	10KF 1/4W			
63	ORN1612G408		16.2KF 1/4W	1	RF1	
64	ORN2612G408		26.1KF 1/4W	1	RF2	
65	ORN2612G408		26.1KF 1/4W	1	RF3	
66						
67	—/—	R,CARBON FILM	F-ROOM COMPENSATION	12K		R1
68						
69	0TR106009AC	TRANSISTOR	KRA106M	4	K.E.C	Q1,2,3,4
70	0TR106009AE		KRC106M			
71	0TR127309AD		KTA1273(KTA966) Y			
72	0TR320509AC		KTC3205(KTC2236) Y			
73	0TR127009AF		KTA1270(KTA562)Y			
74	6600JB8001A	TEST S/W		1		TEST
75	0LA0102K018	INDUCTOR	10uH		TAE YANG	L1(J)
76	43607015	JUMP WIRE	0.6*10mm			
77						
78			0.6*10mm	5		J01,02,04,05,15
79				2		OP1,OP2
80			0.6*5mm			
81			0.6*7.5mm	3		J12~J14
82						
83						
84	43607015	JUMP WIRE				
85						
86						
87			0.6*12.5mm	4		J06~J09
88						
89						
90						
91						
92						
93						
94						
95	43607015	JUMP WIRE	0.6*15mm	2		J10,J11
96						
97						
98						
99	6877JB2034A	L,WIRE ASSY, FD/H				
100	4920JB3001A	HEAT SINK(5V)	(=J572-00002A)			(IC3)
101	4920JB3002A	HEAT SINK(12V)	(=J572-00003A)	1		
102	4920JB3003A	HEAT SINK(12V)	(=J572-00004A)			(IC2)
103	1SBF0302418	SCREW		1		
104	49111001	SOLDER	ALMIT KR-19RMA	3.0g		
105	49111004	SOLDER LEAD BAR	H63A	25g		
106	59333105	FLUX AUTO	JS71	1.5g	KOKI	

### 3) PWB ASSEMBLY, DISPLAY AND PARTS LIST

품번 NO.	도 번 DWG. NO.	품 명 DESCRIPTION	재 질 MATERIAL	소재지수 SPEC.	수량 QTY.	MAKER	비 고 REMARK
1	6870JB2025	PWB,DISPLAY	FR-1(DS-1107A)		1A	DOOSAN	
2	6630JB8005B	WAFER	SMAW250-09			YEON HO	
3	6600JB8004A	TACT S/W	KPT-1109R		2	KYUNG IN	SW101,SW103
4	6600JB8005A	TACT S/W	KPT-1105A		1	KYUNG IN	SW102
5							
6	0DL300359AA	LED	SH30-R03CA570GT	GREEN	5	SEOUL SEMI.	L1~L5
7	0DD414809AA	S/W DIODE	1N4148		3	ROHM	D101~D103
8	6500JB3001A	SENSOR	PBN-43		1	계원스텍	RT-SENSOR
9	6877JB2049A	L/WIRE ASSY.	FD/H		1		
10							
11							
12							
13							
14	43607015	JUMP WIRE	0.6*6mm		1		J04
15		JUMP WIRE	0.6*10mm		2		J02,J03
16		JUMP WIRE	0.6*12.5mm		1		J01
17	49111001	SOLDER	ALMIT KR-19RMA		2g	희성금속	
18	49111004	SOLDER LEAD BAR	S63S-B20		5g	희성,대진 SOLD'	
19	59333105	FLUX AUTO	JS71		0.5g	KOKI	
20	————	희석제	IPA			KOKI, 주) 유공	

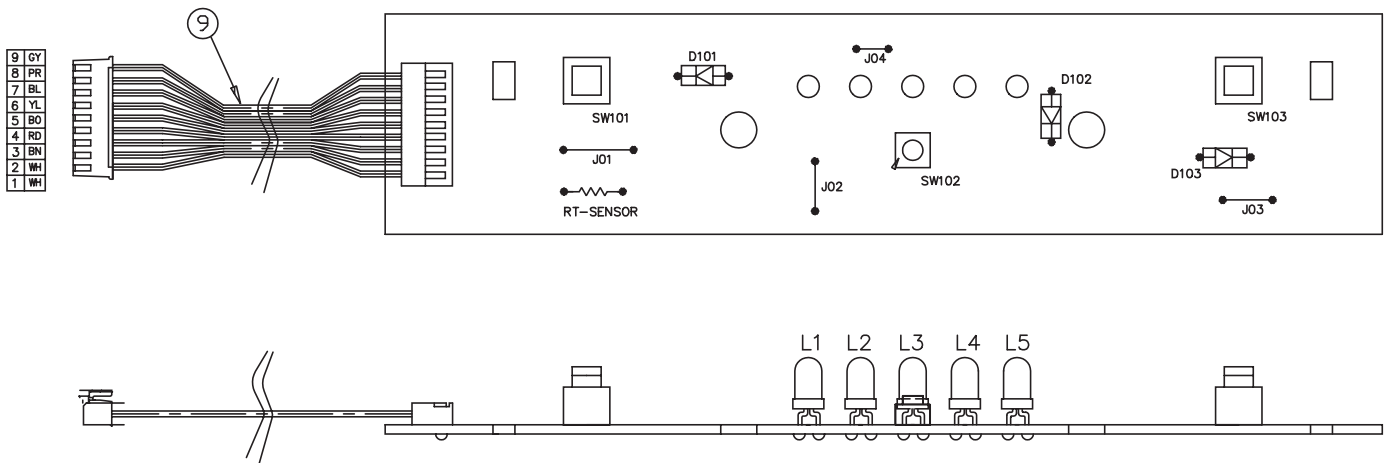

5. PWB circuit drawing- The PWB circuit drawing may change without notice.

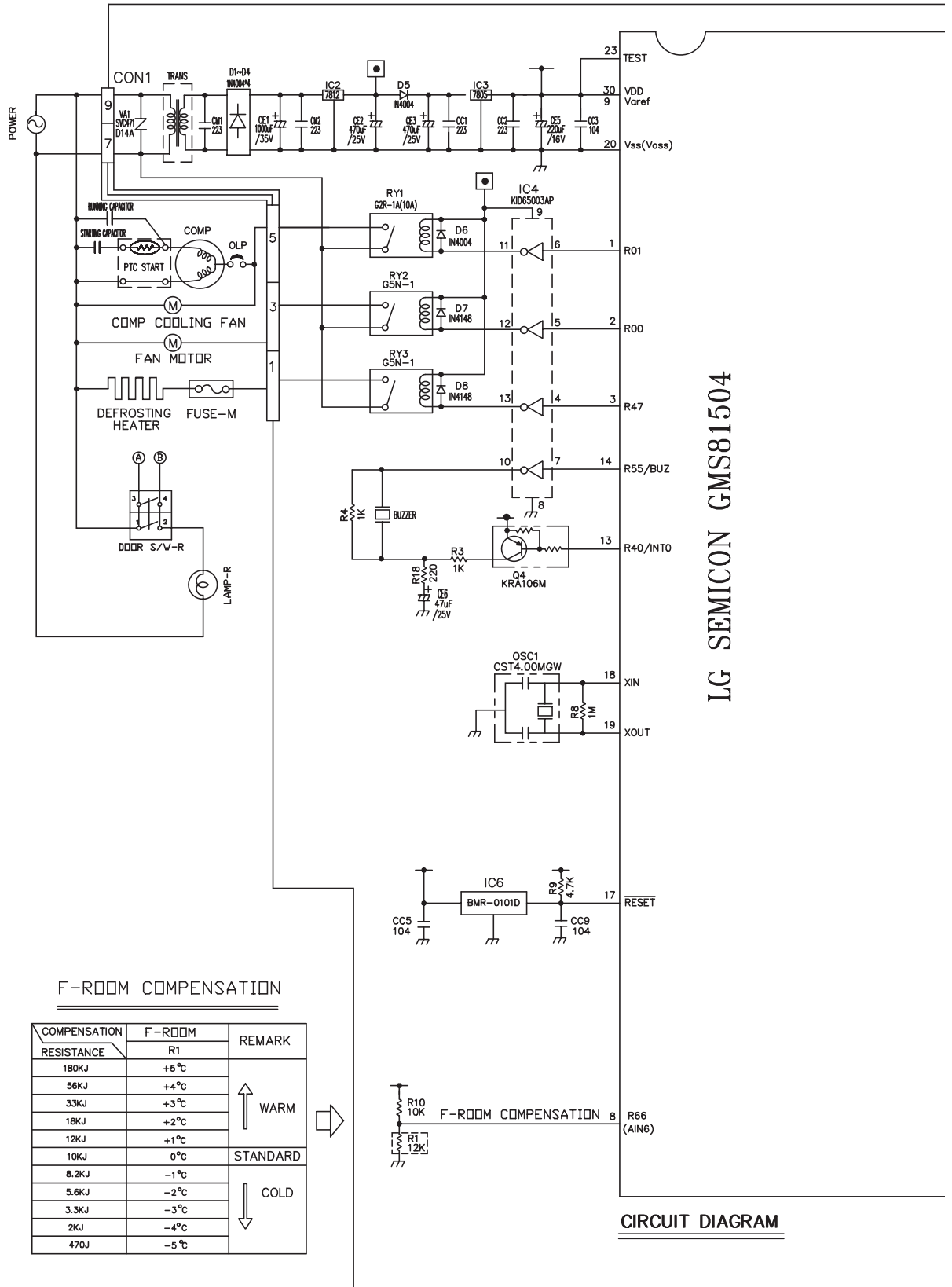



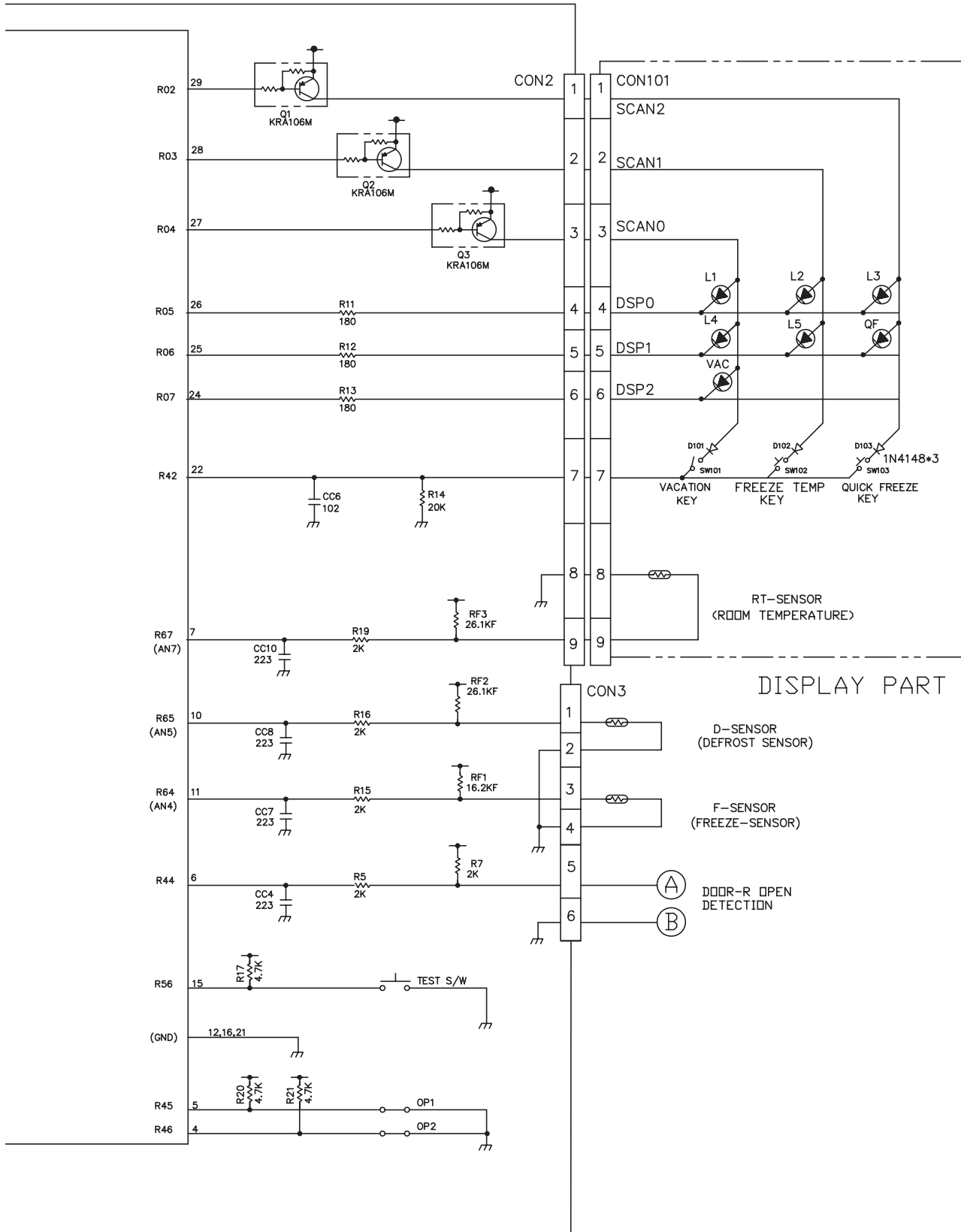

DISPLAY PART

# EXPLODED VIEW & REPLACEMENT PARTS LIST

1.Ref. No : GR-349\*\*\*\*

