



LG

REFRIGERATOR

SERVICE MANUAL

CAUTION
BEFORE SERVICING THE UNIT,
READ THE SAFETY PRECAUTIONS IN THIS MANUAL.

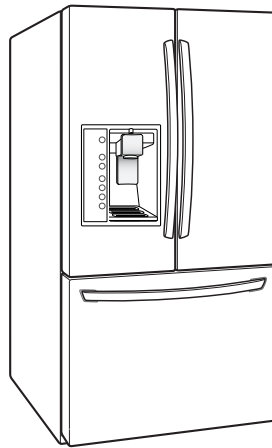

MODEL : LFX31925**

COLOR : STAINLESS(ST)
SMOOTH BLACK(SB)
SUPER WHITE(SW)

CONTENTS

SAFETY PRECAUTIONS	2
1. SPECIFICATIONS	3
2. PARTS IDENTIFICATION	4
3. DISASSEMBLY	5-
REMOVING AND REPLACING REFRIGERATOR DOORS	5
DOOR	6
DOOR ALIGNMENT	7
FAN AND FAN MOTOR.....	7
DEFROST CONTROL ASSEMBLY	7
REFRIGERATOR LIGHT (TOP)	8-9
MULTI DUCT	9
DISPENSER	10
DISPLAY PCB	10
ICE BUTTON ASSEMBLY	10
WATER BUTTON ASSMEBLY	10
ICE CORNER DOOR REPLACEMENT	10
ICEMAKER REPLACEMENT	11
SUB PCB FOR WORKING DISPENSER	11
CAP DUCT MOTOR REPLACEMENT	12
HOW TO REMOVE A ICE BIN	13
HOW TO INSERT A ICE BIN	13
HOW TO REMOVE AND REINSTALL THE PULLOUT DRAWER	14-15
WATER VALVE DISASSEMBLY METHOD	16
FAN AND FAN MOTOR DISASSEMBLY METHOD.....	16
PULL OUT DRAWER	17
CAUTION : SEALED SYSTEM REPAIR	18
4. ADJUSTMENT	19
COMPRESSOR.....	19
5. CIRCUIT DIAGRAM	20
6. TROUBLESHOOTING	21
7. PCB PICTURE	22-23
8. Troubleshooting With Error Display	24-35
9. Troubleshooting Without Error Display	36-44
10. Reference	35-50
11. COMPONENT TESTING INFORMATION	51-59
12. TROUBLESHOOTING	60-72
13. ICEMAKER OPEARTING AND TROUBLE SHOOTING METHOD	73-76
14. DESCRIPTION OF FUNCTION & CIRCUIT OF MICOM	77-80

SAFETY PRECAUTIONS

Please read the following instructions before servicing your refrigerator.

1. Unplug the power before handling any elctrical componets.
2. Check the rated current, voltage, and capacity.
3. Take caution not to get water near any electrical components.
4. Use exact replacement parts.
5. Remove any objects from the top prior to tilting the product.

1. SPECIFICATIONS

1-1 LFX31925**

● 31 cu.ft.

ITEMS	SPECIFICATIONS
DOOR DESIGN	Side Rounded
DIMENSIONS (inches)	35 3/4 X 36 1/4 X 70 1/4 (WDXH) 31cu.ft.
NET WEIGHT (pounds)	158kg (348lb)
COOLING SYSTEM	Fan Cooling
TEMPERATURE CONTROL	Micom Control
DEFROSTING SYSTEM	Full Automatic Heater Defrost
DOOR FINISH	PCM, VCM, Stainless
HANDLE TYPE	Bar
INNER CASE	ABS Resin
INSULATION	Polyurethane Foam

ITEMS	SPECIFICATIONS	
VEGETABLE TRAY	Clear Drawer Type	
COMPRESSOR	Linear	
EVAPORATOR	Fin Tube Type	
CONDENSER	Spiral Condenser	
REFRIGERANT	R-134a (135 g)	
LUBRICATING OIL	ISO10 (280 ml)	
DEFROSTING DEVICE	SHEATH HEATER	
LAMP	REFRIGERATOR	LED Module
	FREEZER	LED Module

● DIMENSIONS

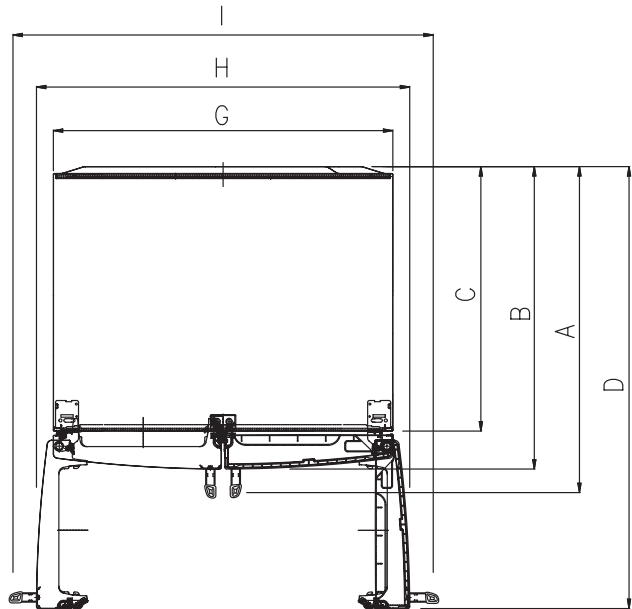
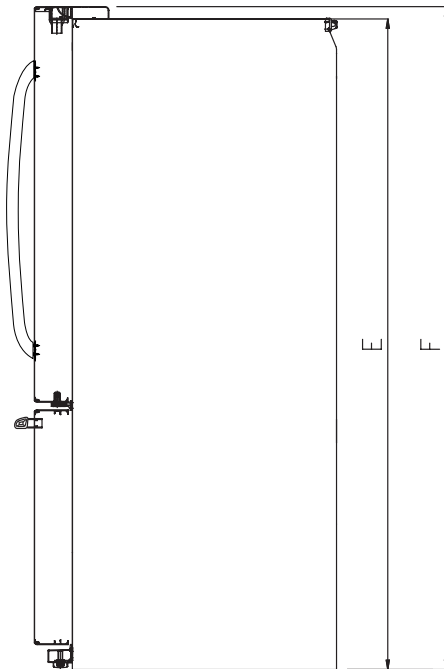

Description		LFX31925**
Depth w/ Handles	A	36 1/4 in
Depth w/o Handles	B	33 3/4 in
Depth w/o Door	C	29 1/2 in
Depth (Total with Door Open)	D	48 1/8 in
Height to Top of Case	E	68 3/4 in
Height to Top of Door Hinge	F	70 1/4 in
Width	G	35 3/4 in
Width (door open 90 deg. w/o handle)	H	40 in
Width (door open 90 deg. w/ handle)	I	45 in

2. PARTS IDENTIFICATION

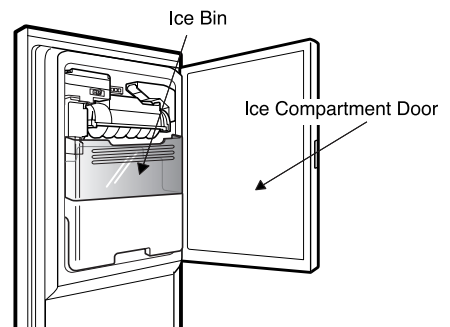
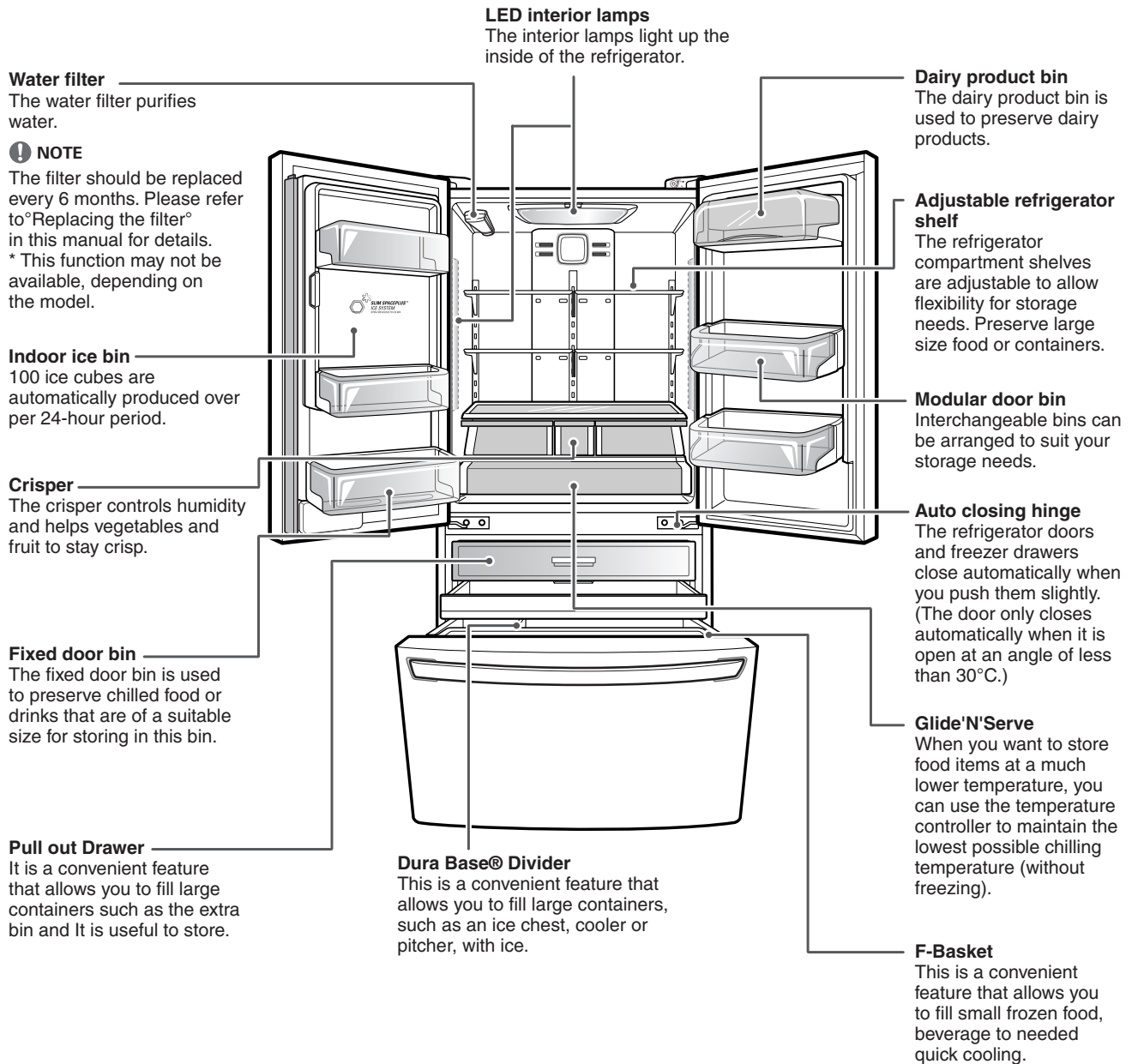

3. DISASSEMBLY

3-1 REMOVING AND REPLACING REFRIGERATOR DOORS

● Removing Refrigerator Door

▲ **CAUTION:** Before you begin, unplug the refrigerator. Remove food and bins from doors.

▶ Left Door -FIG. 2

1. Disconnect water supply tube by pushing back on the disconnect ring (3).-FIG. 1
2. Open door. Loosen top hinge cover screw (1).
- Use flat tip screwdriver to pry back hooks on front underside of cover (2). Lift up cover.
3. Disconnect door switch wire harness and remove the cover.
4. Pull out the tube.
5. Disconnect all 3 wiring harnesses (4). Remove the grounding screw (5).
6. Rotate hinge lever (6) counterclockwise. Lift top hinge (7) free of hinge lever latch (8).

▲ **CAUTION:** When lifting hinge free from the latch, be careful that door does not fall forward.

7. Lift door from middle hinge pin and remove door.
8. Place the door with the insides facing up, on a not scratch surface.

▶ Right Door -FIG. 3

1. Open the door, remove 1 screw on the top of the hinge cover. Loosen top hinge cover screw (1). Lift up cover (2).
2. Disconnect door switch wire harness and remove the cover.
3. Rotate hinge lever (3) clockwise. Lift top hinge (4) free of hinge lever latch (5).
4. Lift door from middle hinge pin and remove door.

▲ **CAUTION:** When lifting hinge free from the latch, be careful that the door does not fall forward.

5. Place the door with the insides facing up, on a not scratch surface.

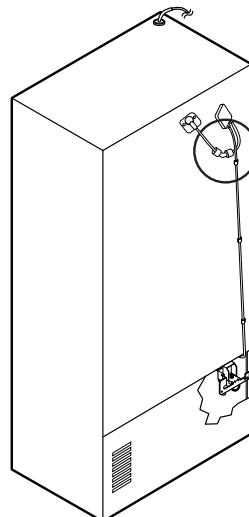
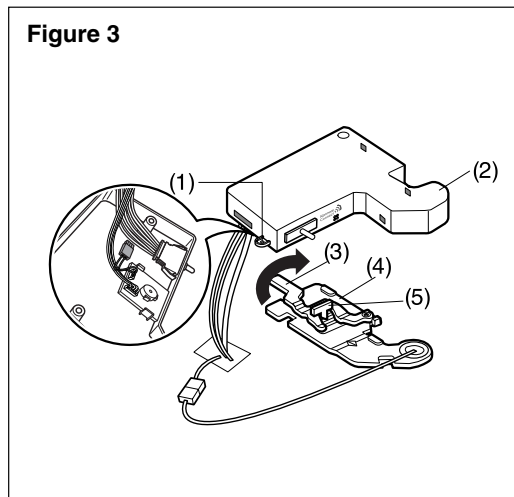
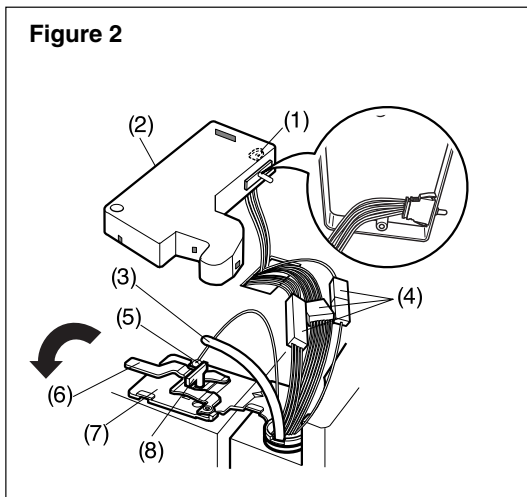
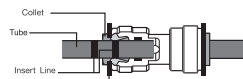
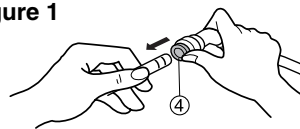

Figure 1



- 1) Insert the tube until you can see only one of the lines printed on the tube.
- 2) After inserting, pull the tube to ascertain that it is secure.
- 3) Assemble clip.

Correct

Incorrect

3-2 DOOR

● Mullion Removal

1. Remove 2 screws.



2. Lift mullion up carefully.



3. Disconnect wire harness.



● Door Gasket Removal

1. Remove gasket

Remove the gasket from gasket channel at doorliner as shown in the illustration below.

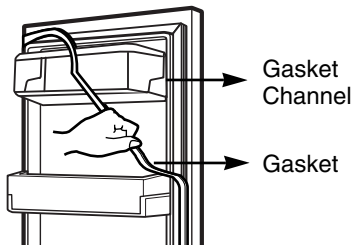

● Door Gasket Replacement

1. Insert gasket into channel

Insert and press gasket into channels at doorliner.

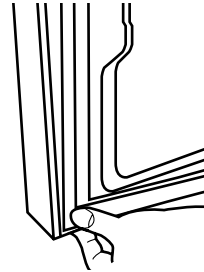

● Mullion Replacement

1. Connect wire harness.



2. Insert mullion into channel.

Insert the mullion into channel at door as shown below.



3. Assemble 2 screws.

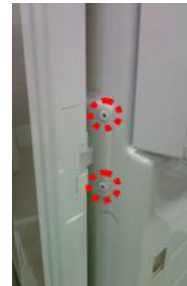

3-3 Door Alignment

If the level of refrigerator doors is uneven, follow the instructions below to align the doors:
Turn the leveling legs (CCW) to raise or (CW) to lower the height of the front of the refrigerator by using flat blade screw driver or 11/32" wrench. Use the wrench (Included with the User Manual) to adjust the bolt in the door hinge to adjust the height. (CW to raise or CCW to lower the height.)

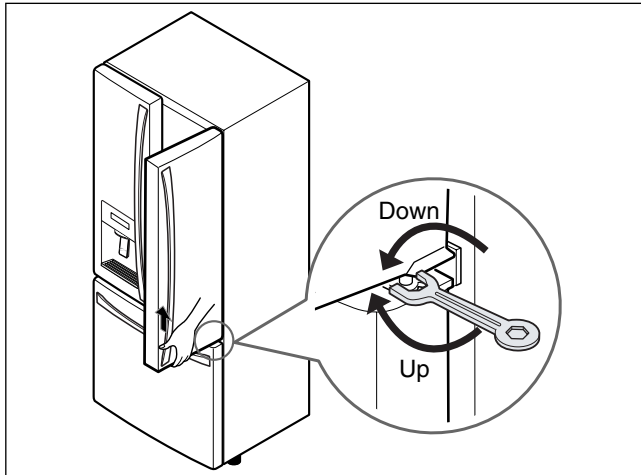

3-4 FAN AND FAN MOTOR

1. Remove the freezer drawer.
2. Remove the plastic guide for slides on left side by unscrewing phillips head screws.
3. Remove the grille assembly by removing four screws and pulling the grille assembly forward.
4. Remove the Fan Motor assembly by loosening 3 screws and disassembling the shroud.
5. Pull out the fan and separate the Fan Motor and Bracket Motor.

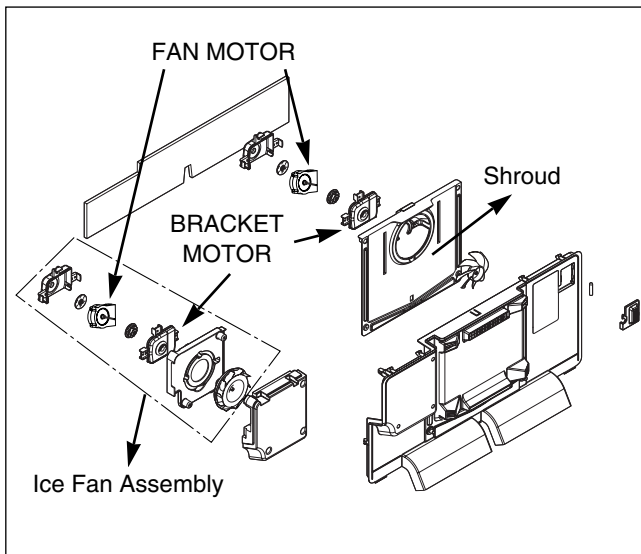

* Ice Fan Assembly Replacement

- 1) Remove the plastic guide for slides on left side by unscrewing phillips head screws.
- 2) Pull out the cover sensor to disassemble by using tools shown in the figure.
- 3) Pull out the cover grille to disassemble by using tools shown in the figure.
- 4) Put your hand into the inside of grille to disassemble shown in the figure.
- 5) Disconnect wire harness of the grille assembly.
- 6) Remove the Ice fan assembly by loosening all screws.



(1)



(2)



(3)



(4)



(5)

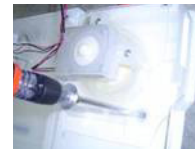

(6)

3-5 DEFROST CONTROL ASSEMBLY

Defrost Control assembly consists of Defrost Sensor and FUSE-M.

The Defrost Sensor works to defrost automatically. It is attached to the metal side of the Evaporator and senses its temperature. At 46F(8°C), it turns the Defrost Heater off. Fuse-M is a safety device for preventing over-heating of the Heater when defrosting.

1. Pull out the grille assembly. (Figure 1)
2. Separate the connector with the Defrost Control assembly and replace the Defrost Control assembly after cutting the Tie Wrap. (Figure 2)

GRILLE ASSEMBLY

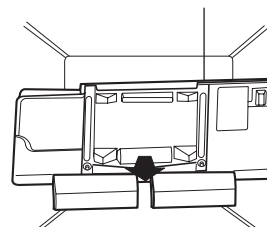

DEFROST-CONTROL ASSEMBLY

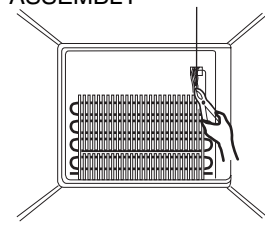

3-6 Refrigerator Light (Top)

Unplug Refrigerator, or disconnect power at the circuit breaker.

If necessary, remove top shelf or shelves.

3-6-1 Refrigerator Compartment Lamp

- 1) Release 2 screws.
- 2) Hold both ends with your both hands and pull it downward to remove it.



- 3) To remove the case lamp and cover lamp, release another 2 screws as following picture.

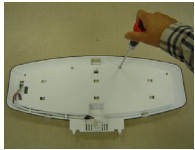

- 4) Use a flat blade screwdriver as shown below to remove the cover lamp.



- 5) To remove the LED Assembly, open the Hook part to pull it out as shown in the following picture.



Cover, lamp

LED, Assembly

Case, lamp

3-6-2 Refrigerator Light (Side)

1. Unplug refrigerator power cord from electric outlet.
2. Put flat screwdriver into sevice hole and remove cover of refrigerator light.

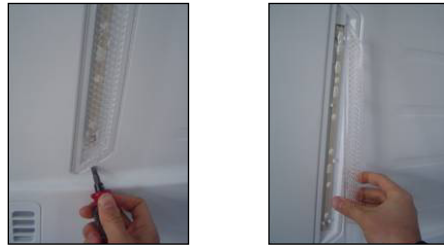

3. Remove the LED assembly from connector.



4. Replace LED assembly.



5. Assemble the cover in reverse order.

3-6-3 Cap Duct LED LAMP(Bottom)

1. Unplug refrigerator power cord from electric outlet.
2. Open the refrigerator door to need diassembly.
3. Put flat screwdriver into service hole, remove the cover of cap duct LED LAMP.



4. Remove the LED assembly from connector.



5. Replace LED assembly.



6. Assembly the cover in reverse order.

3-7 MULTI DUCT

1. Remove 2 screws and guide rail.

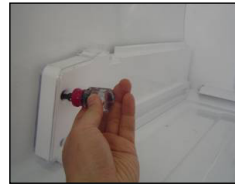

2. Remove the upper and lower Caps by using a flat screwdriver and remove 2 screws as shown figure.



3. Disconnect the lead wire on the bottom position



4. Grip both side of multi duct, pull it out.



3-8 DISPENSER



1) Pull out the drain



2) Holding the inner side of the dispenser pull forward to remove.



3) If nozzle is interfered with button, push and pull out the bottom of button.



4) Remove the lead wire.

⚠ CAUTION: When replacing the dispenser cover make sure the lead wire does NOT come off and the water line is not pinched by the dispenser.



3-9 DISPLAY PCB

As shown below, remove 1 screw on the PCB fixing screw. Remove the display PCB fixing screw.



Case, PCB

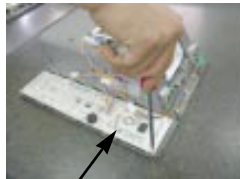

Display PCB

3-10 ICE BUTTON ASSEMBLY

- 1) Remove the 1 screw holding the lever.
- 2) Remove the spring from the hook.
- 3) Push and pull on the tab to remove.

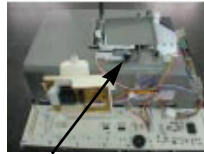

Button Lever



3-11 WATER BUTTON ASSEMBLY

- 1) Remove screws.
- 2) Grasp the Button assembly and lift.

Button Lever



3-12 ICE CORNER DOOR REPLACEMENT

- 1) Loosen the front screw as shown in the picture.
- 2) Lift up the hinge with one hand.
- 3) Pull out the Ice Corner Door with the other hand.



3-13 ICEMAKER REPLACEMENT

1) Remove 4 screws as shown.



2) Grasp the bottom of motor cover assembly and pull slowly.



3) Disconnect wire harness from wall of compartment.

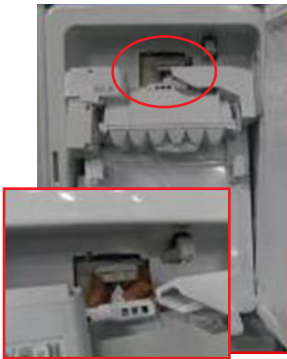

In-door motor

▲ CAUTION: Make sure that the motor housing is taped to the mold, if not positioned correctly the cover will not fit properly.



3-14 SUB PCB FOR WORKING DISPENSER

1) Disconnect the wire harness.



2) Remove 1 screw from PCB and replace with new PCB.



3-15 CAP DUCT MOTOR REPLACEMENT

1) Separate the Housing of the Cap Duct Motor.



2) Unscrew 3 screws to disassemble the motor.



3) When replacing the motor, check the position of the door duct and the link for proper fit.

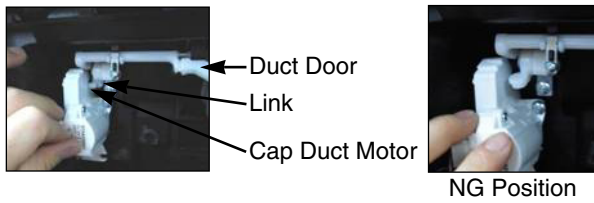

4) Insert 2 screws.



5) Push housing aside.



3-16 HOW TO REMOVE A ICE BIN

1) Grip the handles, as shown.

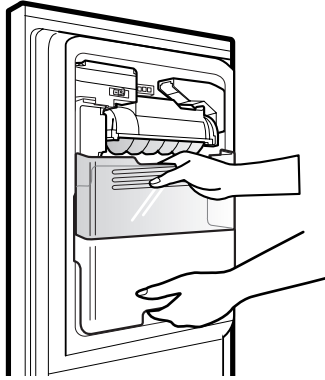

2) Tilt and lift slightly as shown.

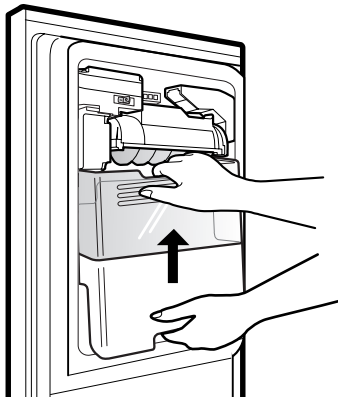

3) Remove ice bin slowly.

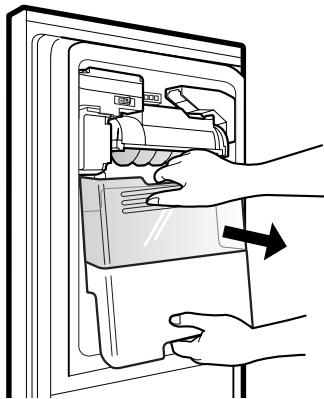

3-17 HOW TO INSERT A ICE BIN

1) Insert the Ice Bin, slightly tilting to avoid touching the Icemaker. (Especially, Ice-Detecting Sensor)

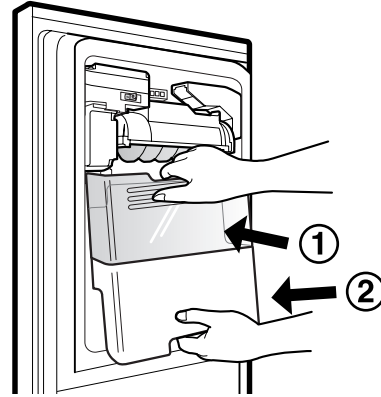

3-18 HOW TO REMOVE AND REINSTALL THE PULLOUT DRAWER

3-18-1 Follow Steps to Remove

Step 1) Open the freezer door.



Step 2) Remove the lower basket.



Step 3) Remove the two screws from the guide rails (one from each side).

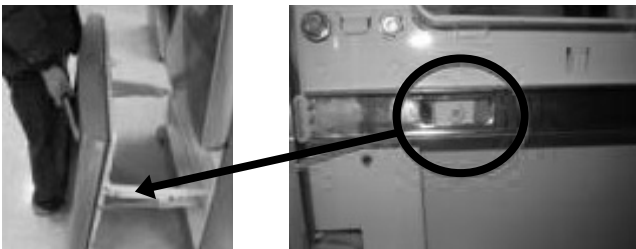

Step 4) Removal of the freezer door is done by lifting clear of the rail support. Fully extend both rails.



Step 5) Remove only 1 screw of gearice, and disassemble the bar and gearice



Step 6) Remove 2 screws of both side of supporter covers tv and disassemble the supporter cover tv.



3-18-2 Follow Steps to Reinstall

Step 1) Insert both side of supporter cover tv into connector rails, and then screw them.



Step 2) ① Assemble a bar and gear ice with screw.
② Push the otherside of the gear to inside of the bar.



Step 3) Put gear ice assembled with the bar by screw into connector rail's hole.

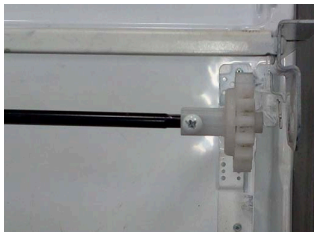

Step 4) Insert opposite gear ice into connector rail and screw them



Step 5) The rail system will align itself by pushing the rails all the way into the freezer section. Pull the rails back out to full extension.

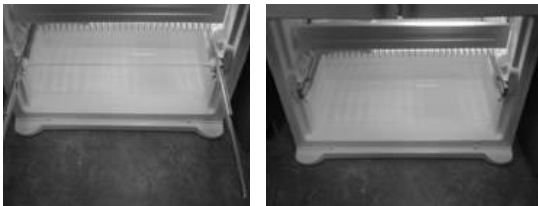

Step 6) Reinstall the freezer door by inserting the rail tabs into the guide rail.



* Assemble them like as pictures

Step 7) Reinstall the two screws into the guide rails (one from each side).

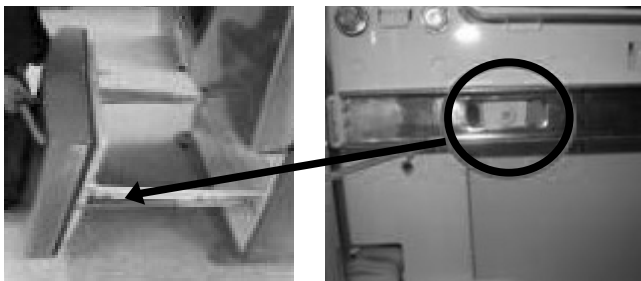

Step 8) Reinstall the lower basket, and close the freezer door.



3-19 WATER VALVE DISASSEMBLY METHOD

- 1) Turn off the water to unit. Remove the waterline from the valve.

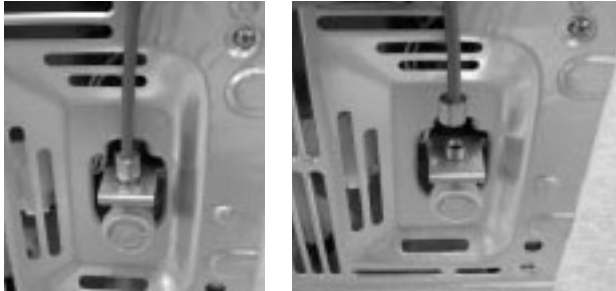

- 2) Remove cover and 1 screw from the valve.

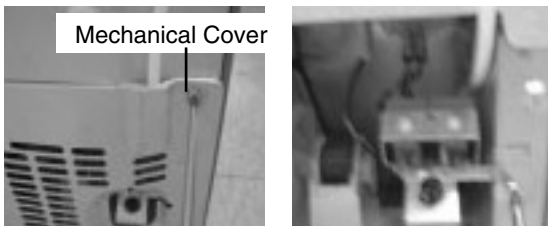

- 3) Separate the housing and remove the valve.



- 4) Remove the clip, and press the collet to separate the tube from the connector. Note: there maybe some water in the line.

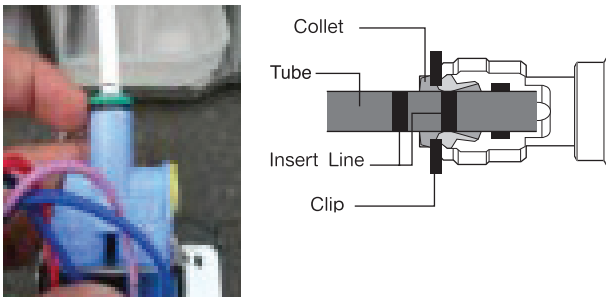

3-20 FAN AND FAN MOTOR DISASSEMBLY METHOD

- 1) Remove screws for the Drain Pipe Assembly and the 1 connected to the Motor Cover.

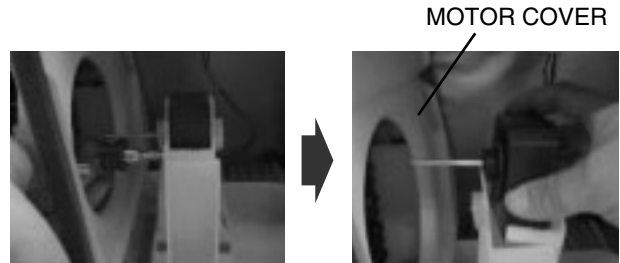

- 2) Separate the Fan Assembly and Motor, turn counter clockwise to remove from the motor shaft.

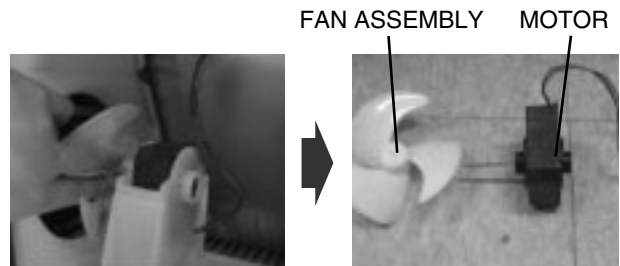

Assemble in reverse order. Taking care to avoid.

1. Do not to bend the tube during assembly.
2. Press the Water Dispenser button letting water pour out, this checks for any leaks in the tube connection, this may vary depending on the water pressure (about 2 minutes.).

3-21 PULL OUT DRAWER

Top Drawer

1. Use a flat blade screwdriver to push the tab in on the left rail and push the tab on the right rail in with your finger.
Once the tabs have been pushed in, you can lift the tray up and out.

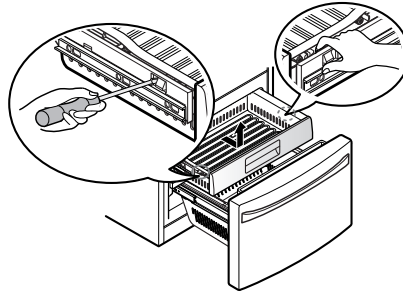

2. Pull both rails out to the full extension and insert the back of the tray into both rails. Then set the front of the tray into the rail and push it until you hear it click into place.

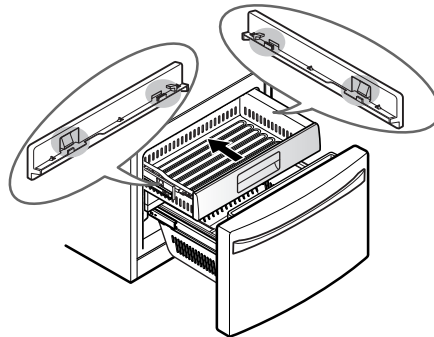

Middle Drawer

1. To remove the middle drawer.
Pull the drawer out to full extension. Lift the front of the drawer up, then pull it straight out.

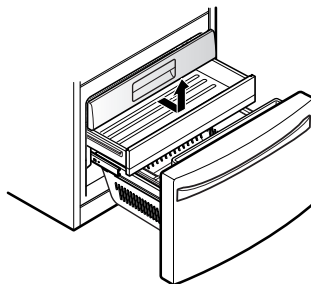

2. To install, slightly tilt up the front and insert the drawer into the frame and push it back into place.

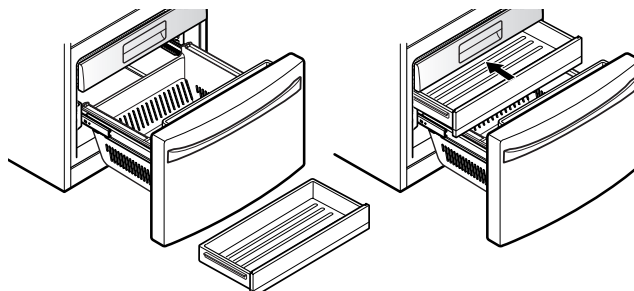

3-22. CAUTION : Sealed System Repair

Before making a sealed system repair : Start with the power cord unplugged from the outlet. Plug in the power cord and between 6 and 12 seconds after it has been plugged in, unplug it from the power source. this will allow both sides of the 3 way valve to be opened to allow for proper evacuation.

3 Way Valve Service

- The 3 way valve has plastic parts inside, so always wrap it with a wet cloth before servicing when using a torch.
- 1) Always replace the 3 way valve if there is a leak at any one of the 3 tubes coming from it.
- 2) Service in replacement of valve (valve failure) Perform service in the same method as above.

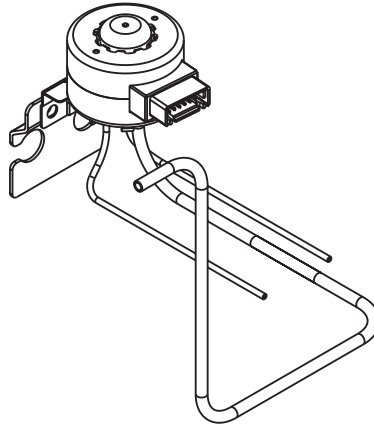

4. ADJUSTMENT

4-1 COMPRESSOR

4-1-1 Role

The compressor intakes low temperature and low pressure gas from the evaporator of the refrigerator and compresses this gas to high-temperature and high-pressure gas. It then delivers the gas to the condenser.

4-1-2 Note for Usage

- (1) Be careful not to allow over-voltage and over-current.
- (2) Do not drop or handle carelessly.
- (3) Keep away from any liquid.
If liquid such as oil or water enters the Cover PTC Compressor may fail due to breakdown of their insulating capabilities.
- (4) Always use the Parts designed for the compressor and make sure it is properly attached to the compressor. Parts may appear physically identical but could have different electrical ratings. Replace parts by part number and model number. Use only approved substitute parts.

4-1-3 Remove the cover PTC



(1) Remove the Cover Back M/C



(2) Remove two screws on comp base



- (3) Use a L-shaped flap tool to pry off the cover
- (4) Assembly in reverse order of disassembly

4-2-3 Compressor protection logic

- Since linear Comp conducts linear reciprocating motion, we have protection logic for compressor, motor and PCB as the below.

- Stroke Trip
During the operation, if stroke is above the target value, decrease the target volt by 3V.
- Current Trip
Current trip is set in order to protect compressor mechanical part and drive from the overcurrent that might arise during the operation.
Check the current for every 416.7us and if the Trip exceeds 1.86Arms more than three times at Comp ON, forcibly stop and restart six minutes later.
- Lock Piston Trip
If stroke is under 5mm even if the current is more than 14Arms, Take it as 'piston lock' and restart after 2'30" of Comp OFF. Check the current and stroke for every 416.7us and if the condition fits more than three times at Comp ON, the Trip occurs.
- IPM fault Trip
It occurs if FO signal received from IPM is LOW. For every 416.7us, check whether FO signal is LOW. The trip occurs if it is found three times during the five periods(83ms).

6. TROUBLESHOOTING

6-1 Error Code Summary

▲ WARNING: When checking Resistance values, make sure to turn off the power, and wait for the voltage to discharge.

NOTE) Within 3 hours after the error : Press the Ice Plus button and Freezer button simultaneously
 3 hours after the error : All errors, except for "Er rt", "Er SS", "Er IS(except for Icing sensor)", "Er gF", "Er It" error, are displayed.
 "Er IS" which is displayed without input of user is the error of Icing Sensor.

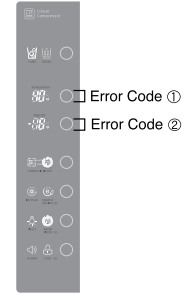



NO	Error Detection Category	Error Display		Error Generation Factors	Remark
		Freezer Temperature (Error code ①)	Refrigerator Temperature (Error code ②)		
1	Normal			None	Normal operation of Display
2	Freezer Sensor Error	Er	FS	Short or Disconnection of Freezer Sensor	Check each sensor at it's connector.
3	Refrigerator Sensor Error	Er	rS	Short or Disconnection of Refrigerator Sensor	
4	Defrosting Sensor Error	Er	dS	Short or Disconnection of Defrosting Sensor	
5	Icing Sensor Error	Er	IS	Short or disconnection of the sensor about Ice maker (Icing sensor, Ice maker sensor)	
6	Pantry sensor error	Er	SS	Short or Disconnection of Pantry Sensor	
7	Room Temp Sensor Error	Er	rt	Short or Disconnectoin of Room temp.sensor	
8	Ice maker kit defect	Er	It	Other Electric system error such as moter, gear, Hall IC, operation circuit within I/M kit	
9	Flow Meter(Sensor) Defect	Er	gF	Error of flow meter or water input or low water pressure	Error of flow meter or water input or low water pressure or flow meter connection
10	Poor Defrosting	Er	dH	Even though it is passed 1 hour since then Defrosting, if Defrosting sensor is not over 46°F(8°C), it is caused	Temperature Fuse Disconnection, Heater disconnection, DRAIN Jam, Poor Relay for Heater
11	Abnormality of BLDC FAN Motor for Ice Making	Er	IF	It is caused when feedback signal isn't over 65 seconds during BLDC FAN motor operating	Poor BLDC Motor connection, DRIVE IC, and TR
12	Abnormality of BLDC FAN Motor for Freezer	Er	FF	It is caused when feedback signal isn't over 65 seconds during BLDC FAN motor operating	Poor BLDC Motor connection, DRIVE IC, and TR
13	Abnormality of BLDC FAN MOTOR For Refrigerator	Er	rF	It is caused when feedback signal isn't over 65 seconds during BLDC FAN motor operating	Poor BLDC Motor connection, DRIVE IC, and TR
14	Abnormality of BLDC FAN Motor for Mechanic Room	Er	CF	It is caused when feedback signal isn't over 65 seconds during BLDC FAN motor operating	Poor BLDC Motor connection, DRIVE IC, and TR
15	Communication Error	Er	CO	Communication Error between Micom of Main PCB and Display Micom	Poor Communication connection,Poor TR of Transmitter and Receiver Tx/Rx between display and main board.

7. PCB PICTURE

7-1 Main PCB

P/No & MFG	Picture
<p>EBR730936 (2011.01~)</p>	

7-2 Display PCB & Sub PCB

P/No	Picture
<p>Display PCB EBR 729554 (2011.03~)</p>	
	
<p>Sub PCB EBR60070709 (2011.01~)</p>	

8. Troubleshooting With Error Display

8-1 Freezer Sensor Error (Er FS)

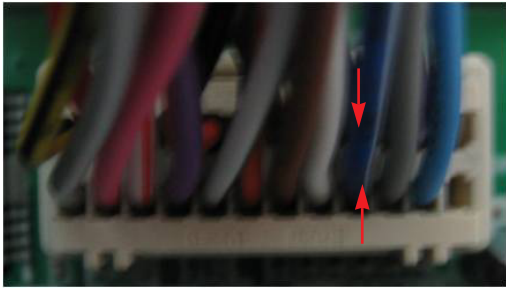
No	Checking flow	Result & SVC Action																												
1	Check for a loose connection.																													
2	<p data-bbox="302 538 613 597">Check the <u>Blue/White to Blue/White.</u></p>  <p data-bbox="508 932 613 959"><CON7></p>	<table border="1" data-bbox="888 555 1448 763"> <thead> <tr> <th colspan="2">Result</th> <th>SVC Action</th> </tr> </thead> <tbody> <tr> <td>0 Ω</td> <td>Short</td> <td>Change the sensor</td> </tr> <tr> <td>OFF</td> <td>Open</td> <td>Replace the refrigerator</td> </tr> <tr> <td>Other</td> <td>Normal</td> <td>Check the Temp and resistance (Table-1)</td> </tr> </tbody> </table> <p data-bbox="1016 804 1304 832"><Temperature table-1></p> <table border="1" data-bbox="945 838 1375 1225"> <thead> <tr> <th>(1) To (2)</th> <th>Result</th> </tr> </thead> <tbody> <tr> <td>-22°F / -30°C</td> <td>40 kΩ</td> </tr> <tr> <td>-13°F / -25°C</td> <td>30 kΩ</td> </tr> <tr> <td>-4°F / -20°C</td> <td>23 kΩ</td> </tr> <tr> <td>5°F / -15°C</td> <td>17 kΩ</td> </tr> <tr> <td>14°F / -10°C</td> <td>13 kΩ</td> </tr> <tr> <td>23°F / -5°C</td> <td>10 kΩ</td> </tr> <tr> <td>32°F / 0°C</td> <td>8 kΩ</td> </tr> </tbody> </table> <p data-bbox="891 1247 1338 1342">※ The sensor is determined by the temperature. For example, 23kΩ indicates -4°F.</p>	Result		SVC Action	0 Ω	Short	Change the sensor	OFF	Open	Replace the refrigerator	Other	Normal	Check the Temp and resistance (Table-1)	(1) To (2)	Result	-22°F / -30°C	40 kΩ	-13°F / -25°C	30 kΩ	-4°F / -20°C	23 kΩ	5°F / -15°C	17 kΩ	14°F / -10°C	13 kΩ	23°F / -5°C	10 kΩ	32°F / 0°C	8 kΩ
Result		SVC Action																												
0 Ω	Short	Change the sensor																												
OFF	Open	Replace the refrigerator																												
Other	Normal	Check the Temp and resistance (Table-1)																												
(1) To (2)	Result																													
-22°F / -30°C	40 kΩ																													
-13°F / -25°C	30 kΩ																													
-4°F / -20°C	23 kΩ																													
5°F / -15°C	17 kΩ																													
14°F / -10°C	13 kΩ																													
23°F / -5°C	10 kΩ																													
32°F / 0°C	8 kΩ																													

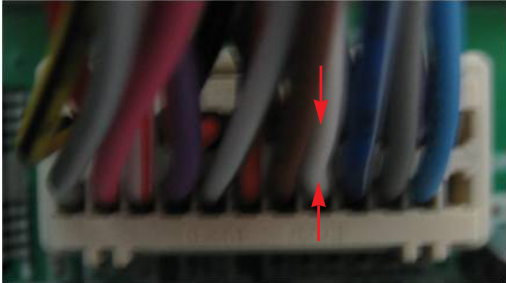

8-2 Refrigerator Sensor Error (Er rS)

No	Checking flow	Result & SVC Action																								
1	Check for a loose connection.																									
2	<p>Check the <u>White to White</u>.</p>  <p><CON7></p>	<table border="1" data-bbox="886 555 1446 763"> <thead> <tr> <th colspan="2">Result</th> <th>SVC Action</th> </tr> </thead> <tbody> <tr> <td>0 Ω</td> <td>Short</td> <td>Change the sensor</td> </tr> <tr> <td>OFF</td> <td>Open</td> <td>Replace the refrigerator</td> </tr> <tr> <td>Other</td> <td>Normal</td> <td>Check the Temp and resistance (Table-2)</td> </tr> </tbody> </table> <p data-bbox="1013 804 1300 834"><Temperature table-2></p> <table border="1" data-bbox="943 838 1373 1129"> <thead> <tr> <th>(1) To (2)</th> <th>Result</th> </tr> </thead> <tbody> <tr> <td>23°F / -5°C</td> <td>38 kΩ</td> </tr> <tr> <td>32°F / 0°C</td> <td>30 kΩ</td> </tr> <tr> <td>41°F / 5°C</td> <td>24 kΩ</td> </tr> <tr> <td>50°F / 10°C</td> <td>19.5 kΩ</td> </tr> <tr> <td>59°F / 15°C</td> <td>16 kΩ</td> </tr> </tbody> </table> <p data-bbox="886 1151 1344 1244">* The sensor is determined by the temperature. For example, 30kΩ indicates 32°F.</p>	Result		SVC Action	0 Ω	Short	Change the sensor	OFF	Open	Replace the refrigerator	Other	Normal	Check the Temp and resistance (Table-2)	(1) To (2)	Result	23°F / -5°C	38 kΩ	32°F / 0°C	30 kΩ	41°F / 5°C	24 kΩ	50°F / 10°C	19.5 kΩ	59°F / 15°C	16 kΩ
Result		SVC Action																								
0 Ω	Short	Change the sensor																								
OFF	Open	Replace the refrigerator																								
Other	Normal	Check the Temp and resistance (Table-2)																								
(1) To (2)	Result																									
23°F / -5°C	38 kΩ																									
32°F / 0°C	30 kΩ																									
41°F / 5°C	24 kΩ																									
50°F / 10°C	19.5 kΩ																									
59°F / 15°C	16 kΩ																									

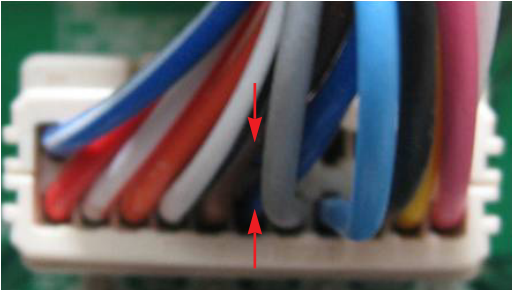
8-3 Icing Sensor Error (Er IS)

No	Checking flow	Result & SVC Action																												
1	Check for a loose connection.																													
2	<p>Check the <u>Blue to Blue</u>.</p>  <p style="text-align: center;"><CON5></p>	<table border="1" data-bbox="889 555 1450 763"> <thead> <tr> <th colspan="2">Result</th> <th>SVC Action</th> </tr> </thead> <tbody> <tr> <td>0 Ω</td> <td>Short</td> <td>Change the sensor</td> </tr> <tr> <td>OFF</td> <td>Open</td> <td>Replace the refrigerator</td> </tr> <tr> <td>Other</td> <td>Normal</td> <td>Check the Temp and resistance (Table-1)</td> </tr> </tbody> </table> <p style="text-align: center;"><Temperature table-1></p> <table border="1" data-bbox="946 840 1377 1227"> <thead> <tr> <th>(1) To (2)</th> <th>Result</th> </tr> </thead> <tbody> <tr> <td>-22°F / -30°C</td> <td>40 kΩ</td> </tr> <tr> <td>-13°F / -25°C</td> <td>30 kΩ</td> </tr> <tr> <td>-4°F / -20°C</td> <td>23 kΩ</td> </tr> <tr> <td>5°F / -15°C</td> <td>17 kΩ</td> </tr> <tr> <td>14°F / -10°C</td> <td>13 kΩ</td> </tr> <tr> <td>23°F / -5°C</td> <td>10 kΩ</td> </tr> <tr> <td>32°F / 0°C</td> <td>8 kΩ</td> </tr> </tbody> </table> <p>※ The sensor is determined by the temperature. For example, 23kΩ indicates -4°F.</p>	Result		SVC Action	0 Ω	Short	Change the sensor	OFF	Open	Replace the refrigerator	Other	Normal	Check the Temp and resistance (Table-1)	(1) To (2)	Result	-22°F / -30°C	40 kΩ	-13°F / -25°C	30 kΩ	-4°F / -20°C	23 kΩ	5°F / -15°C	17 kΩ	14°F / -10°C	13 kΩ	23°F / -5°C	10 kΩ	32°F / 0°C	8 kΩ
Result		SVC Action																												
0 Ω	Short	Change the sensor																												
OFF	Open	Replace the refrigerator																												
Other	Normal	Check the Temp and resistance (Table-1)																												
(1) To (2)	Result																													
-22°F / -30°C	40 kΩ																													
-13°F / -25°C	30 kΩ																													
-4°F / -20°C	23 kΩ																													
5°F / -15°C	17 kΩ																													
14°F / -10°C	13 kΩ																													
23°F / -5°C	10 kΩ																													
32°F / 0°C	8 kΩ																													

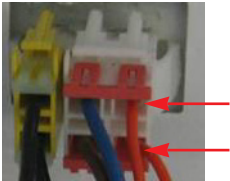
8-4 Defrost Sensor Error (F dS)

No	Checking flow	Result & SVC Action																								
1	<p>Check for a loose connection.</p> 																									
2	<p>Check the <u>Orange to Orange</u>.</p>  <p>Check the <u>Brown to Brown</u>.</p>  <p><CON7></p>	<table border="1" data-bbox="886 755 1446 966"> <thead> <tr> <th colspan="2">Result</th> <th>SVC Action</th> </tr> </thead> <tbody> <tr> <td>0 Ω</td> <td>Short</td> <td>Change the sensor</td> </tr> <tr> <td>OFF</td> <td>Open</td> <td>Replace the refrigerator</td> </tr> <tr> <td>Other</td> <td>Normal</td> <td>Check the Temp and resistance (Table-3)</td> </tr> </tbody> </table> <p data-bbox="1013 1006 1300 1034"><Temperature table-3></p> <table border="1" data-bbox="943 1040 1373 1332"> <thead> <tr> <th>(1) To (2)</th> <th>Result</th> </tr> </thead> <tbody> <tr> <td>23°F / -5°C</td> <td>38 kΩ</td> </tr> <tr> <td>32°F / 0°C</td> <td>30 kΩ</td> </tr> <tr> <td>41°F / 5°C</td> <td>24 kΩ</td> </tr> <tr> <td>50°F / 10°C</td> <td>19.5 kΩ</td> </tr> <tr> <td>59°F / 15°C</td> <td>16 kΩ</td> </tr> </tbody> </table> <p data-bbox="886 1366 1338 1459"> ※ The sensor is determined by the temperature. For example, 23kΩ indicates -4°F. </p>	Result		SVC Action	0 Ω	Short	Change the sensor	OFF	Open	Replace the refrigerator	Other	Normal	Check the Temp and resistance (Table-3)	(1) To (2)	Result	23°F / -5°C	38 kΩ	32°F / 0°C	30 kΩ	41°F / 5°C	24 kΩ	50°F / 10°C	19.5 kΩ	59°F / 15°C	16 kΩ
Result		SVC Action																								
0 Ω	Short	Change the sensor																								
OFF	Open	Replace the refrigerator																								
Other	Normal	Check the Temp and resistance (Table-3)																								
(1) To (2)	Result																									
23°F / -5°C	38 kΩ																									
32°F / 0°C	30 kΩ																									
41°F / 5°C	24 kΩ																									
50°F / 10°C	19.5 kΩ																									
59°F / 15°C	16 kΩ																									

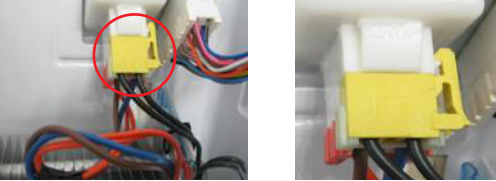
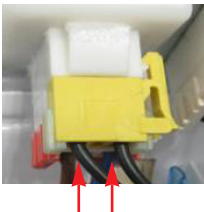
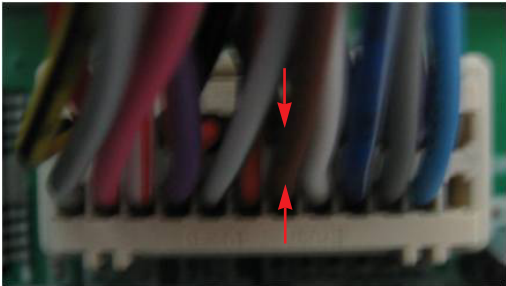

8-5 Defrost Sensor Error (R dS)

No	Checking flow	Result & SVC Action																								
1	<p>Check for a loose connection.</p> 																									
2	<p>Check the <u>Orange to Orange</u>.</p>  <p>Check the <u>Gray to Gray</u>.</p>  <p><CON7></p>	<table border="1" data-bbox="889 755 1450 968"> <thead> <tr> <th colspan="2">Result</th> <th>SVC Action</th> </tr> </thead> <tbody> <tr> <td>0 Ω</td> <td>Short</td> <td>Change the sensor</td> </tr> <tr> <td>OFF</td> <td>Open</td> <td>Replace the refrigerator</td> </tr> <tr> <td>Other</td> <td>Normal</td> <td>Check the Temp and resistance (Table-3)</td> </tr> </tbody> </table> <p data-bbox="1015 1006 1307 1038"><Temperature table-3></p> <table border="1" data-bbox="946 1038 1377 1330"> <thead> <tr> <th>(1) To (2)</th> <th>Result</th> </tr> </thead> <tbody> <tr> <td>23°F / -5°C</td> <td>38 kΩ</td> </tr> <tr> <td>32°F / 0°C</td> <td>30 kΩ</td> </tr> <tr> <td>41°F / 5°C</td> <td>24 kΩ</td> </tr> <tr> <td>50°F / 10°C</td> <td>19.5 kΩ</td> </tr> <tr> <td>59°F / 15°C</td> <td>16 kΩ</td> </tr> </tbody> </table> <p data-bbox="889 1368 1339 1464">※ The sensor is determined by the temperature. For example, 23kΩ indicates -4°F.</p>	Result		SVC Action	0 Ω	Short	Change the sensor	OFF	Open	Replace the refrigerator	Other	Normal	Check the Temp and resistance (Table-3)	(1) To (2)	Result	23°F / -5°C	38 kΩ	32°F / 0°C	30 kΩ	41°F / 5°C	24 kΩ	50°F / 10°C	19.5 kΩ	59°F / 15°C	16 kΩ
Result		SVC Action																								
0 Ω	Short	Change the sensor																								
OFF	Open	Replace the refrigerator																								
Other	Normal	Check the Temp and resistance (Table-3)																								
(1) To (2)	Result																									
23°F / -5°C	38 kΩ																									
32°F / 0°C	30 kΩ																									
41°F / 5°C	24 kΩ																									
50°F / 10°C	19.5 kΩ																									
59°F / 15°C	16 kΩ																									

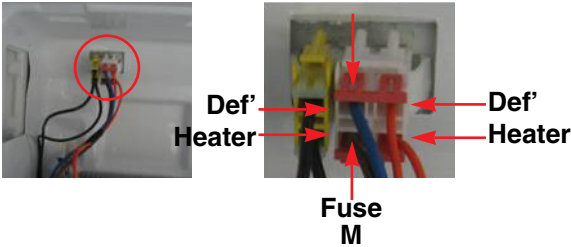
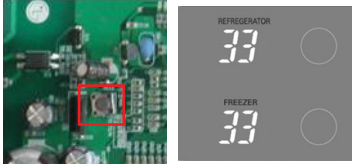
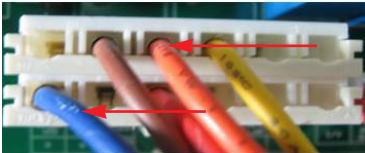
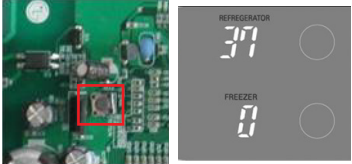
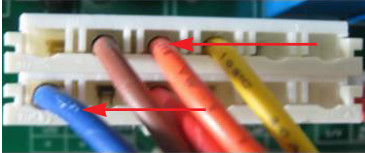

8-6 Defrost Heater Error (F dH)

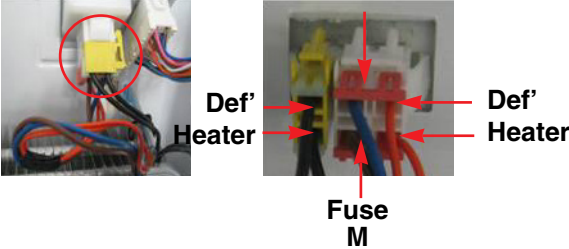
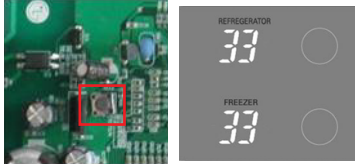
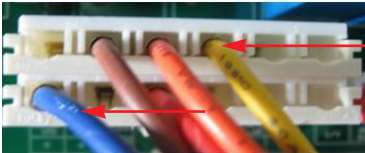
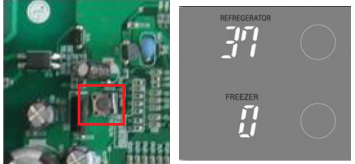
No	Checking flow	Result & SVC Action																		
1	Check the <u>Door gasket.</u>																			
2	Check the <u>Defrost control part.</u> 	<table border="1"> <thead> <tr> <th data-bbox="885 474 1024 512">Part</th> <th data-bbox="1024 474 1190 512">Result</th> <th data-bbox="1190 474 1446 512">SVC Action</th> </tr> </thead> <tbody> <tr> <td data-bbox="885 512 1024 614" rowspan="2">Fuse-M</td> <td data-bbox="1024 512 1190 566">0 Ω</td> <td data-bbox="1190 512 1446 566">Go to the 3</td> </tr> <tr> <td data-bbox="1024 566 1190 614">Other</td> <td data-bbox="1190 566 1446 614">Change Fuse-M</td> </tr> <tr> <td data-bbox="885 614 1024 708" rowspan="2">Def' Heater</td> <td data-bbox="1024 614 1190 668">34~42 Ω</td> <td data-bbox="1190 614 1446 668">Go to the 3</td> </tr> <tr> <td data-bbox="1024 668 1190 708">Other</td> <td data-bbox="1190 668 1446 708">Change Fuse-M</td> </tr> <tr> <td data-bbox="885 708 1024 802" rowspan="2">Def' Sensor</td> <td data-bbox="1024 708 1190 761">22 kΩ ↑</td> <td data-bbox="1190 708 1446 761">Go to the 3</td> </tr> <tr> <td data-bbox="1024 761 1190 802">OFF</td> <td data-bbox="1190 761 1446 802">Replace product</td> </tr> </tbody> </table>	Part	Result	SVC Action	Fuse-M	0 Ω	Go to the 3	Other	Change Fuse-M	Def' Heater	34~42 Ω	Go to the 3	Other	Change Fuse-M	Def' Sensor	22 kΩ ↑	Go to the 3	OFF	Replace product
Part	Result	SVC Action																		
Fuse-M	0 Ω	Go to the 3																		
	Other	Change Fuse-M																		
Def' Heater	34~42 Ω	Go to the 3																		
	Other	Change Fuse-M																		
Def' Sensor	22 kΩ ↑	Go to the 3																		
	OFF	Replace product																		
3	Input Test 3 Mode. (Push the button 3 times)																			
4	Check the <u>Blue to Orange.</u>  <CON3>	<table border="1"> <thead> <tr> <th data-bbox="927 1166 1141 1208">Result</th> <th data-bbox="1141 1166 1406 1208">SVC Action</th> </tr> </thead> <tbody> <tr> <td data-bbox="927 1208 1141 1261">112 ~ 116 V</td> <td data-bbox="1141 1208 1406 1261">Go to the 5</td> </tr> <tr> <td data-bbox="927 1261 1141 1315">0 V</td> <td data-bbox="1141 1261 1406 1315">Replace Main PCB</td> </tr> </tbody> </table>	Result	SVC Action	112 ~ 116 V	Go to the 5	0 V	Replace Main PCB												
Result	SVC Action																			
112 ~ 116 V	Go to the 5																			
0 V	Replace Main PCB																			
5	Release the test mode. push the button 1 times. (normal)																			
6	Check the <u>Blue to Orange.</u>  <CON3>	<table border="1"> <thead> <tr> <th data-bbox="927 1730 1141 1772">Result</th> <th data-bbox="1141 1730 1406 1772">SVC Action</th> </tr> </thead> <tbody> <tr> <td data-bbox="927 1772 1141 1825">0 V</td> <td data-bbox="1141 1772 1406 1825">Explain to customer</td> </tr> <tr> <td data-bbox="927 1825 1141 1879">112 ~ 116 V</td> <td data-bbox="1141 1825 1406 1879">Replace Main PCB</td> </tr> </tbody> </table>	Result	SVC Action	0 V	Explain to customer	112 ~ 116 V	Replace Main PCB												
Result	SVC Action																			
0 V	Explain to customer																			
112 ~ 116 V	Replace Main PCB																			

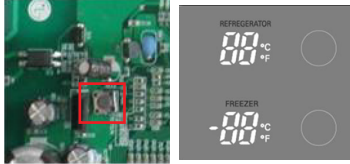

8-7 Defrost Heater Error (R dH)

No	Checking flow	Result & SVC Action																		
1	Check the <u>Door gasket.</u>																			
2	<p>Check the <u>Defrost control part.</u></p> 	<table border="1"> <thead> <tr> <th data-bbox="889 474 1024 512">Part</th> <th data-bbox="1024 474 1192 512">Result</th> <th data-bbox="1192 474 1446 512">SVC Action</th> </tr> </thead> <tbody> <tr> <td data-bbox="889 512 1024 612" rowspan="2">Fuse-M</td> <td data-bbox="1024 512 1192 566">0 Ω</td> <td data-bbox="1192 512 1446 566">Go to the 3</td> </tr> <tr> <td data-bbox="1024 566 1192 612">Other</td> <td data-bbox="1192 566 1446 612">Change Fuse-M</td> </tr> <tr> <td data-bbox="889 612 1024 712" rowspan="2">Def' Heater</td> <td data-bbox="1024 612 1192 666">34~42 Ω</td> <td data-bbox="1192 612 1446 666">Go to the 3</td> </tr> <tr> <td data-bbox="1024 666 1192 712">Other</td> <td data-bbox="1192 666 1446 712">Change Fuse-M</td> </tr> <tr> <td data-bbox="889 712 1024 802" rowspan="2">Def' Sensor</td> <td data-bbox="1024 712 1192 759">22 kΩ ↑</td> <td data-bbox="1192 712 1446 759">Go to the 3</td> </tr> <tr> <td data-bbox="1024 759 1192 802">OFF</td> <td data-bbox="1192 759 1446 802">Replace product</td> </tr> </tbody> </table>	Part	Result	SVC Action	Fuse-M	0 Ω	Go to the 3	Other	Change Fuse-M	Def' Heater	34~42 Ω	Go to the 3	Other	Change Fuse-M	Def' Sensor	22 kΩ ↑	Go to the 3	OFF	Replace product
Part	Result	SVC Action																		
Fuse-M	0 Ω	Go to the 3																		
	Other	Change Fuse-M																		
Def' Heater	34~42 Ω	Go to the 3																		
	Other	Change Fuse-M																		
Def' Sensor	22 kΩ ↑	Go to the 3																		
	OFF	Replace product																		
3	<p>Input Test 3 Mode. (Push the button 3 times)</p>																			
4	<p>Check the <u>Blue to Yellow.</u></p>  <p><CON3></p>	<table border="1"> <thead> <tr> <th data-bbox="930 1166 1143 1208">Result</th> <th data-bbox="1143 1166 1406 1208">SVC Action</th> </tr> </thead> <tbody> <tr> <td data-bbox="930 1208 1143 1261">112 ~ 116 V</td> <td data-bbox="1143 1208 1406 1261">Go to the 5</td> </tr> <tr> <td data-bbox="930 1261 1143 1315">0 V</td> <td data-bbox="1143 1261 1406 1315">Replace Main PCB</td> </tr> </tbody> </table>	Result	SVC Action	112 ~ 116 V	Go to the 5	0 V	Replace Main PCB												
Result	SVC Action																			
112 ~ 116 V	Go to the 5																			
0 V	Replace Main PCB																			
5	<p>Release the test mode. push the button 1 times. (normal)</p>																			
6	<p>Check the <u>Blue to Yellow.</u></p>  <p><CON3></p>	<table border="1"> <thead> <tr> <th data-bbox="930 1730 1143 1772">Result</th> <th data-bbox="1143 1730 1406 1772">SVC Action</th> </tr> </thead> <tbody> <tr> <td data-bbox="930 1772 1143 1825">0 V</td> <td data-bbox="1143 1772 1406 1825">Explain to customer</td> </tr> <tr> <td data-bbox="930 1825 1143 1879">112 ~ 116 V</td> <td data-bbox="1143 1825 1406 1879">Replace Main PCB</td> </tr> </tbody> </table>	Result	SVC Action	0 V	Explain to customer	112 ~ 116 V	Replace Main PCB												
Result	SVC Action																			
0 V	Explain to customer																			
112 ~ 116 V	Replace Main PCB																			

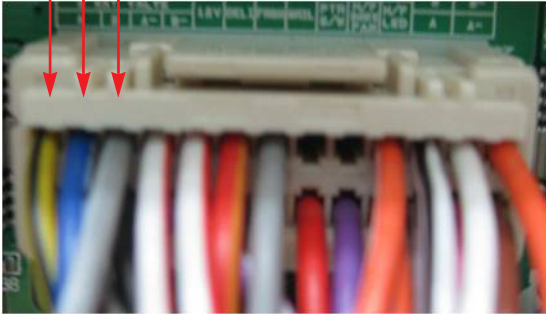

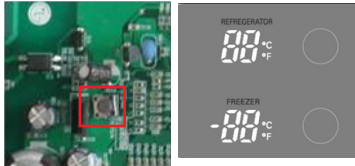

8-8 Refrigerator Fan Error (Er rF)

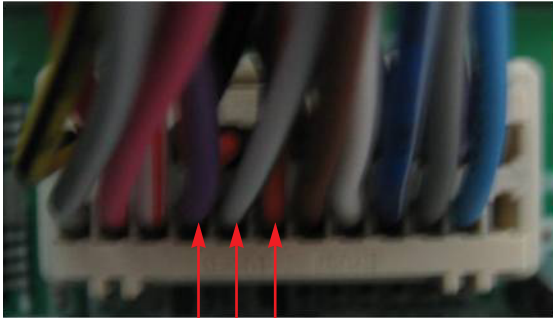
No	Checking flow	Result & SVC Action									
1	<p>Reset the unit and Input Test 1 Mode. (Push the button 1 time)</p>										
2	<p>Open the freezer door and Check the air flow. ※ While an error code is displayed, the fan is not working.</p>	 <table border="1" data-bbox="1127 719 1450 863"> <thead> <tr> <th>Status</th> <th>SVC Action</th> </tr> </thead> <tbody> <tr> <td>No windy</td> <td>Go to 3</td> </tr> <tr> <td>Windy</td> <td>Go to 4</td> </tr> </tbody> </table>	Status	SVC Action	No windy	Go to 3	Windy	Go to 4			
Status	SVC Action										
No windy	Go to 3										
Windy	Go to 4										
4	<p>Check the <u>Fan motor voltage.</u> (3)(2)(1)</p>  <p style="text-align: center;"><CON6></p>	<table border="1" data-bbox="886 976 1446 1121"> <thead> <tr> <th>Point</th> <th>Result</th> <th>SVC Action</th> </tr> </thead> <tbody> <tr> <td>(1) ~ (2)</td> <td>Below 12 V</td> <td>Change the PCB</td> </tr> <tr> <td>(1) ~ (3)</td> <td>0 or 5 V</td> <td>Change the motor</td> </tr> </tbody> </table>	Point	Result	SVC Action	(1) ~ (2)	Below 12 V	Change the PCB	(1) ~ (3)	0 or 5 V	Change the motor
Point	Result	SVC Action									
(1) ~ (2)	Below 12 V	Change the PCB									
(1) ~ (3)	0 or 5 V	Change the motor									

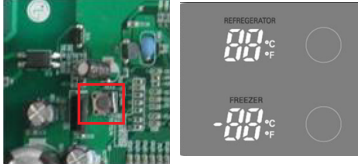

8-9 Freezer Fan Error (Er FF)

No	Checking flow	Result & SVC Action									
1	<p>Reset the unit and Input Test 1 Mode. (Push the button 1 time)</p>										
2	<p>Open the freezer door and Check the air flow. ※ While an error code is displayed, the fan is not working.</p>	 <table border="1" data-bbox="1128 719 1453 863"> <thead> <tr> <th>Status</th> <th>SVC Action</th> </tr> </thead> <tbody> <tr> <td>No windy</td> <td>Go to 3</td> </tr> <tr> <td>Windy</td> <td>Go to 4</td> </tr> </tbody> </table>	Status	SVC Action	No windy	Go to 3	Windy	Go to 4			
Status	SVC Action										
No windy	Go to 3										
Windy	Go to 4										
3	<p>Check the <u>Fan motor</u>.</p> 	<p>Rotate fan using your hand. It feel sticky, change the motor. (cause of ice or rust inside of motor)</p>									
4	<p>Check the <u>Fan motor voltage</u>.</p>  <p>(3)(2)(1) <CON7></p>	<table border="1" data-bbox="889 1293 1450 1438"> <thead> <tr> <th>Point</th> <th>Result</th> <th>SVC Action</th> </tr> </thead> <tbody> <tr> <td>(1) ~ (2)</td> <td>Below 12 V</td> <td>Change the PCB</td> </tr> <tr> <td>(1) ~ (3)</td> <td>0 or 5 V</td> <td>Change the motor</td> </tr> </tbody> </table>	Point	Result	SVC Action	(1) ~ (2)	Below 12 V	Change the PCB	(1) ~ (3)	0 or 5 V	Change the motor
Point	Result	SVC Action									
(1) ~ (2)	Below 12 V	Change the PCB									
(1) ~ (3)	0 or 5 V	Change the motor									

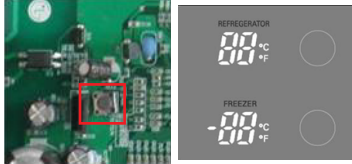

8-10 Icing Fan Error (Er IF)

No	Checking flow	Result & SVC Action									
1	<p>Reset the unit and Input Test 1 Mode. (Push the button 1 time)</p>										
2	<p>Open the freezer door and Check the air flow. ※ While an error code is displayed, the fan is not working.</p>	 <table border="1" data-bbox="1127 655 1451 804"> <thead> <tr> <th>Status</th> <th>SVC Action</th> </tr> </thead> <tbody> <tr> <td>No windy</td> <td>Go to the 3,4</td> </tr> <tr> <td>Windy</td> <td>Go to the 5</td> </tr> </tbody> </table>	Status	SVC Action	No windy	Go to the 3,4	Windy	Go to the 5			
Status	SVC Action										
No windy	Go to the 3,4										
Windy	Go to the 5										
3	<p>Check the <u>Connector</u>. (Frozen caused the PCB short)</p> 										
4	<p>Check the <u>Fan motor voltage</u>.</p> <p>(3) (2) (1)</p>  <p><CON7></p>	<table border="1" data-bbox="886 1193 1446 1336"> <thead> <tr> <th>Point</th> <th>Result</th> <th>SVC Action</th> </tr> </thead> <tbody> <tr> <td>(1) ~ (2)</td> <td>Below 9 V</td> <td>Change the PCB</td> </tr> <tr> <td>(1) ~ (3)</td> <td>0 or 5 V</td> <td>Change the motor</td> </tr> </tbody> </table>	Point	Result	SVC Action	(1) ~ (2)	Below 9 V	Change the PCB	(1) ~ (3)	0 or 5 V	Change the motor
Point	Result	SVC Action									
(1) ~ (2)	Below 9 V	Change the PCB									
(1) ~ (3)	0 or 5 V	Change the motor									

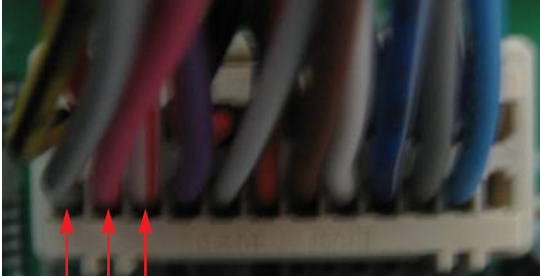
8-11 Condenser Fan Error (Er CF)

No	Checking flow	Result & SVC Action									
1	<p>Reset the unit and Input Test 1 Mode. (Push the button 1 time)</p>										
2	<p>Check the fan rotating. ※ While an error code is displayed, the fan is not working.</p>	 <table border="1" data-bbox="1130 655 1453 802"> <thead> <tr> <th>Status</th> <th>SVC Action</th> </tr> </thead> <tbody> <tr> <td>No windy</td> <td>Check motor</td> </tr> <tr> <td>Windy</td> <td>Go to the 4</td> </tr> </tbody> </table>	Status	SVC Action	No windy	Check motor	Windy	Go to the 4			
Status	SVC Action										
No windy	Check motor										
Windy	Go to the 4										
3	<p>Check the <u>Fan motor</u> and <u>surrounding</u>.</p> 	<p>Rotate fan using your hand. It feel sticky, change the motor.</p>									
4	<p>Check the <u>Fan motor voltage</u>.</p>  <p>(3) (2) (1) <CON7></p>	<table border="1" data-bbox="886 1204 1446 1349"> <thead> <tr> <th>Point</th> <th>Result</th> <th>SVC Action</th> </tr> </thead> <tbody> <tr> <td>(1) ~ (2)</td> <td>Below 10 V</td> <td>Change the PCB</td> </tr> <tr> <td>(1) ~ (3)</td> <td>0 or 5 V</td> <td>Change the motor</td> </tr> </tbody> </table>	Point	Result	SVC Action	(1) ~ (2)	Below 10 V	Change the PCB	(1) ~ (3)	0 or 5 V	Change the motor
Point	Result	SVC Action									
(1) ~ (2)	Below 10 V	Change the PCB									
(1) ~ (3)	0 or 5 V	Change the motor									

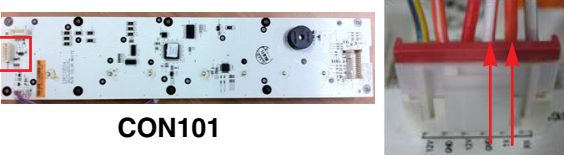
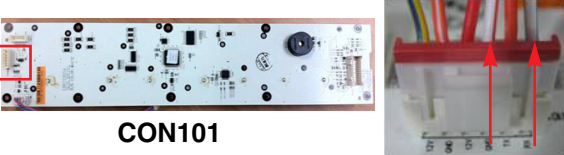
8-12 Communication Error (Er CO)

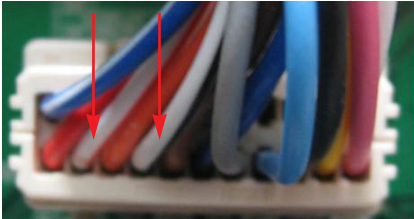

No	Checking flow	Result & SVC Action						
1	Check the loose connection.							
2	<p>Check the <u>Red to White/Red.</u></p>  <p>CON101 <Display></p> <p><CON101></p>	<table border="1"> <thead> <tr> <th>Result</th> <th>SVC Action</th> </tr> </thead> <tbody> <tr> <td>12 V</td> <td>Go to the 3</td> </tr> <tr> <td>Other</td> <td>Check the Hinge (loose connection) Change the Main PCB</td> </tr> </tbody> </table>	Result	SVC Action	12 V	Go to the 3	Other	Check the Hinge (loose connection) Change the Main PCB
Result	SVC Action							
12 V	Go to the 3							
Other	Check the Hinge (loose connection) Change the Main PCB							
3	<p>Check the <u>Orange to White/Red.</u></p>  <p>CON101 <Display></p> <p><CON101></p>	<table border="1"> <thead> <tr> <th>Result</th> <th>SVC Action</th> </tr> </thead> <tbody> <tr> <td>0 or 5 V</td> <td>Change the Display PCB</td> </tr> <tr> <td>Other</td> <td>Go to the 4</td> </tr> </tbody> </table>	Result	SVC Action	0 or 5 V	Change the Display PCB	Other	Go to the 4
Result	SVC Action							
0 or 5 V	Change the Display PCB							
Other	Go to the 4							
4	<p>Check the <u>White/Black to White/Red.</u></p>  <p>CON101 <Display></p> <p><CON101></p>	<table border="1"> <thead> <tr> <th>Result</th> <th>SVC Action</th> </tr> </thead> <tbody> <tr> <td>0 or 5 V</td> <td>Change the Main PCB</td> </tr> <tr> <td>Other</td> <td>Go to the 5</td> </tr> </tbody> </table>	Result	SVC Action	0 or 5 V	Change the Main PCB	Other	Go to the 5
Result	SVC Action							
0 or 5 V	Change the Main PCB							
Other	Go to the 5							
5	<p>Check the <u>White/Red to Orange.</u></p>  <p><CON5></p>	<table border="1"> <thead> <tr> <th>Result</th> <th>SVC Action</th> </tr> </thead> <tbody> <tr> <td>0 or 5 V</td> <td>Change the Display PCB</td> </tr> <tr> <td>Other</td> <td>Go to the 6</td> </tr> </tbody> </table>	Result	SVC Action	0 or 5 V	Change the Display PCB	Other	Go to the 6
Result	SVC Action							
0 or 5 V	Change the Display PCB							
Other	Go to the 6							
6	<p>Check the <u>White/Red to White/Black.</u></p>  <p><CON5></p>	<table border="1"> <thead> <tr> <th>Result</th> <th>SVC Action</th> </tr> </thead> <tbody> <tr> <td>0 or 5 V</td> <td>Change the Main PCB</td> </tr> <tr> <td>Other</td> <td>Explain to customer</td> </tr> </tbody> </table>	Result	SVC Action	0 or 5 V	Change the Main PCB	Other	Explain to customer
Result	SVC Action							
0 or 5 V	Change the Main PCB							
Other	Explain to customer							

9. Troubleshooting Without Error Display

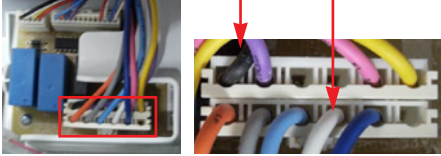
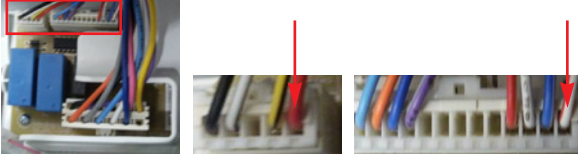
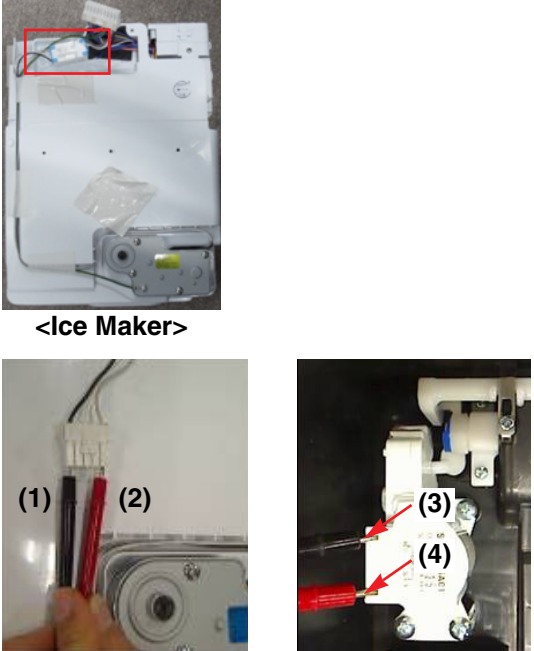
9-1 Cube mode doesn't work

No	Checking flow	Result & SVC Action													
1	Check the loose connection.														
2	<p>Check the Black to White. (While pushing the lever S/W)</p>  <p style="text-align: center;"><CON2></p>	<table border="1"> <thead> <tr> <th>Lever s/w</th> <th>Result</th> <th>SVC Action</th> </tr> </thead> <tbody> <tr> <td rowspan="2">Pushing</td> <td>112 ~ 115 V</td> <td>Go to the 3</td> </tr> <tr> <td>Other</td> <td>Change PCB</td> </tr> <tr> <td rowspan="2">Not pushing</td> <td>0 ~ 2 V</td> <td>Go to the 3</td> </tr> <tr> <td>Other</td> <td>Change PCB</td> </tr> </tbody> </table>	Lever s/w	Result	SVC Action	Pushing	112 ~ 115 V	Go to the 3	Other	Change PCB	Not pushing	0 ~ 2 V	Go to the 3	Other	Change PCB
Lever s/w	Result	SVC Action													
Pushing	112 ~ 115 V	Go to the 3													
	Other	Change PCB													
Not pushing	0 ~ 2 V	Go to the 3													
	Other	Change PCB													
3	<p>Check the RED to White Red. (While pushing the lever S/W)</p>  <p style="text-align: center;"><CON3> <CON1></p>	<table border="1"> <thead> <tr> <th>Lever s/w</th> <th>Result</th> <th>SVC Action</th> </tr> </thead> <tbody> <tr> <td rowspan="2">Pushing</td> <td>9 ~ 12 V</td> <td>Go to the 4</td> </tr> <tr> <td>Other</td> <td>Change PCB</td> </tr> <tr> <td rowspan="2">Not pushing</td> <td>0 ~ 2 V</td> <td>Go to the 4</td> </tr> <tr> <td>Other</td> <td>Change PCB</td> </tr> </tbody> </table>	Lever s/w	Result	SVC Action	Pushing	9 ~ 12 V	Go to the 4	Other	Change PCB	Not pushing	0 ~ 2 V	Go to the 4	Other	Change PCB
Lever s/w	Result	SVC Action													
Pushing	9 ~ 12 V	Go to the 4													
	Other	Change PCB													
Not pushing	0 ~ 2 V	Go to the 4													
	Other	Change PCB													
4	<p>Check the resistance value.</p>  <p style="text-align: center;"><Ice Maker></p> <p style="text-align: center;"><Dispenser Motor></p>	<table border="1"> <thead> <tr> <th>Point</th> <th>Result</th> <th>SVC Action</th> </tr> </thead> <tbody> <tr> <td rowspan="2">(1) to (2)</td> <td>31.1 ~ 42.1 Ω</td> <td>Explain</td> </tr> <tr> <td>Other</td> <td>Replace Geared Motor</td> </tr> <tr> <td rowspan="2">(3) to (4)</td> <td>9.9 ~ 12.1 Ω</td> <td>Explain</td> </tr> <tr> <td>Other</td> <td>Replace Geared Motor</td> </tr> </tbody> </table>	Point	Result	SVC Action	(1) to (2)	31.1 ~ 42.1 Ω	Explain	Other	Replace Geared Motor	(3) to (4)	9.9 ~ 12.1 Ω	Explain	Other	Replace Geared Motor
Point	Result	SVC Action													
(1) to (2)	31.1 ~ 42.1 Ω	Explain													
	Other	Replace Geared Motor													
(3) to (4)	9.9 ~ 12.1 Ω	Explain													
	Other	Replace Geared Motor													

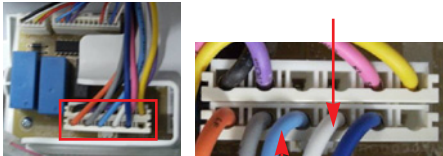
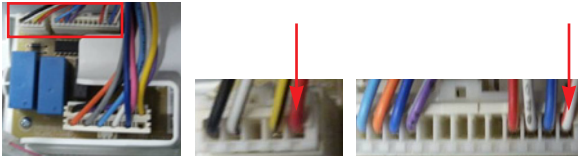

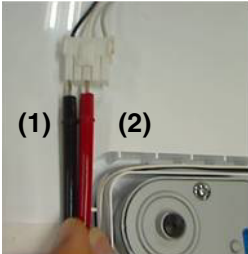
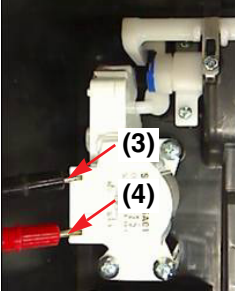
9-2 Crush mode doesn't work

No	Checking flow	Result & SVC Action													
1	Check the loose connection.														
2	<p>Check the <u>Sky Blue to White</u>. (While pushing the lever S/W)</p>  <p style="text-align: center;"><CON2></p>	<table border="1"> <thead> <tr> <th>Lever s/w</th> <th>Result</th> <th>SVC Action</th> </tr> </thead> <tbody> <tr> <td rowspan="2">Pushing</td> <td>112 ~ 115 V</td> <td>Go to the 3</td> </tr> <tr> <td>Other</td> <td>Change PCB</td> </tr> <tr> <td rowspan="2">Not pushing</td> <td>0 ~ 2 V</td> <td>Go to the 3</td> </tr> <tr> <td>Other</td> <td>Change PCB</td> </tr> </tbody> </table>	Lever s/w	Result	SVC Action	Pushing	112 ~ 115 V	Go to the 3	Other	Change PCB	Not pushing	0 ~ 2 V	Go to the 3	Other	Change PCB
Lever s/w	Result	SVC Action													
Pushing	112 ~ 115 V	Go to the 3													
	Other	Change PCB													
Not pushing	0 ~ 2 V	Go to the 3													
	Other	Change PCB													
3	<p>Check the <u>Black to White Red</u>. (While pushing the lever S/W)</p>  <p style="text-align: center;"><CON3> <CON1></p>	<table border="1"> <thead> <tr> <th>Lever s/w</th> <th>Result</th> <th>SVC Action</th> </tr> </thead> <tbody> <tr> <td rowspan="2">Pushing</td> <td>9 ~ 12 V</td> <td>Go to the 4</td> </tr> <tr> <td>Other</td> <td>Change PCB</td> </tr> <tr> <td rowspan="2">Not pushing</td> <td>0 ~ 2 V</td> <td>Go to the 4</td> </tr> <tr> <td>Other</td> <td>Change PCB</td> </tr> </tbody> </table>	Lever s/w	Result	SVC Action	Pushing	9 ~ 12 V	Go to the 4	Other	Change PCB	Not pushing	0 ~ 2 V	Go to the 4	Other	Change PCB
Lever s/w	Result	SVC Action													
Pushing	9 ~ 12 V	Go to the 4													
	Other	Change PCB													
Not pushing	0 ~ 2 V	Go to the 4													
	Other	Change PCB													
4	<p>Check the resistance value.</p>  <p style="text-align: center;"><Ice Maker></p>  <p style="text-align: center;"><Geared Motor></p>  <p style="text-align: center;"><Dispenser Motor></p>	<table border="1"> <thead> <tr> <th>Point</th> <th>Result</th> <th>SVC Action</th> </tr> </thead> <tbody> <tr> <td rowspan="2">(1) to (2)</td> <td>31.1 ~ 42.1 Ω</td> <td>Explain</td> </tr> <tr> <td>Other</td> <td>Replace Geared Motor</td> </tr> <tr> <td rowspan="2">(3) to (4)</td> <td>9.9 ~ 12.1 Ω</td> <td>Explain</td> </tr> <tr> <td>Other</td> <td>Replace Geared Motor</td> </tr> </tbody> </table>	Point	Result	SVC Action	(1) to (2)	31.1 ~ 42.1 Ω	Explain	Other	Replace Geared Motor	(3) to (4)	9.9 ~ 12.1 Ω	Explain	Other	Replace Geared Motor
Point	Result	SVC Action													
(1) to (2)	31.1 ~ 42.1 Ω	Explain													
	Other	Replace Geared Motor													
(3) to (4)	9.9 ~ 12.1 Ω	Explain													
	Other	Replace Geared Motor													

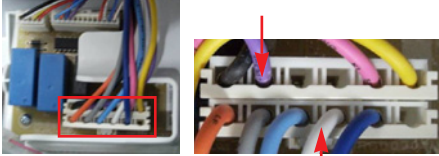
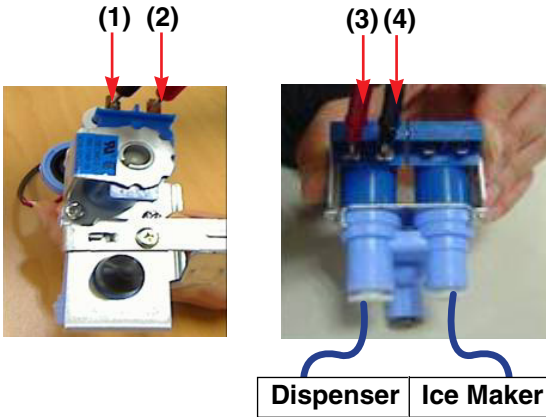

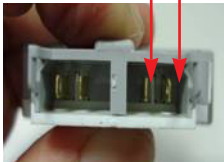

9-3 Water mode doesn't work

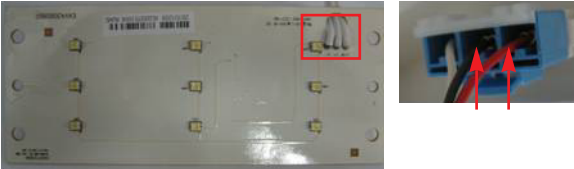
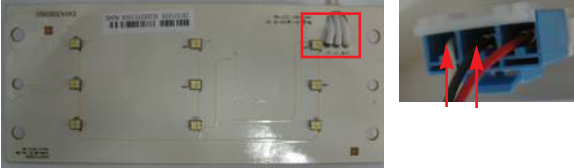
No	Checking flow	Result & SVC Action													
1	Check the loose connection.														
2	<p>Check the Purple to White. (While pushing the lever S/W)</p>  <p style="text-align: center;"><CON2></p>	<table border="1"> <thead> <tr> <th>Lever s/w</th> <th>Result</th> <th>SVC Action</th> </tr> </thead> <tbody> <tr> <td rowspan="2">Pushing</td> <td>112 ~ 115 V</td> <td>Go to the 3</td> </tr> <tr> <td>Other</td> <td>Change PCB</td> </tr> <tr> <td rowspan="2">Not pushing</td> <td>0 ~2 V</td> <td>Go to the 3</td> </tr> <tr> <td>Other</td> <td>Change PCB</td> </tr> </tbody> </table>	Lever s/w	Result	SVC Action	Pushing	112 ~ 115 V	Go to the 3	Other	Change PCB	Not pushing	0 ~2 V	Go to the 3	Other	Change PCB
Lever s/w	Result	SVC Action													
Pushing	112 ~ 115 V	Go to the 3													
	Other	Change PCB													
Not pushing	0 ~2 V	Go to the 3													
	Other	Change PCB													
3	<p>Check the resistance value.</p>  <p style="text-align: center;"> <Pilot Valve> Machine Room <Water Valve> In door </p>	<table border="1"> <thead> <tr> <th>Point</th> <th>Result</th> <th>SVC Action</th> </tr> </thead> <tbody> <tr> <td rowspan="2">(1) to (2)</td> <td>360 ~ 420Ω</td> <td>Explain</td> </tr> <tr> <td>Other</td> <td>Replace Water Valve</td> </tr> <tr> <td rowspan="2">(3) to (4)</td> <td>360 ~ 420Ω</td> <td>Explain</td> </tr> <tr> <td>Other</td> <td>Replace Water Valve</td> </tr> </tbody> </table>	Point	Result	SVC Action	(1) to (2)	360 ~ 420Ω	Explain	Other	Replace Water Valve	(3) to (4)	360 ~ 420Ω	Explain	Other	Replace Water Valve
Point	Result	SVC Action													
(1) to (2)	360 ~ 420Ω	Explain													
	Other	Replace Water Valve													
(3) to (4)	360 ~ 420Ω	Explain													
	Other	Replace Water Valve													

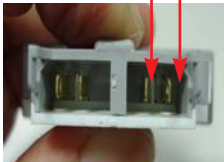

9-4 Freezer room lamp doesn't work

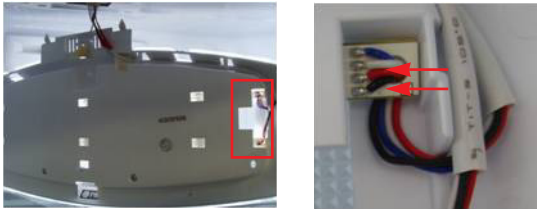
No	Checking flow	Result & SVC Action													
1	<p>Check the Freezer door switch.</p> 	<p>If feel sticky, Change the door s/w.</p>													
2	<p>Check the <u>door S/W resistance</u>.</p> 	<table border="1"> <thead> <tr> <th>Status</th> <th>Result</th> <th>SVC Action</th> </tr> </thead> <tbody> <tr> <td rowspan="2">Normal</td> <td>0Ω</td> <td>Go to the 3</td> </tr> <tr> <td>not</td> <td>Change door S/W</td> </tr> <tr> <td rowspan="2">Push S/W</td> <td>Infinity</td> <td>Go to the 3</td> </tr> <tr> <td>Other</td> <td>Change door S/W</td> </tr> </tbody> </table>	Status	Result	SVC Action	Normal	0Ω	Go to the 3	not	Change door S/W	Push S/W	Infinity	Go to the 3	Other	Change door S/W
Status	Result	SVC Action													
Normal	0Ω	Go to the 3													
	not	Change door S/W													
Push S/W	Infinity	Go to the 3													
	Other	Change door S/W													
3	<p>Check the <u>Red/yellow to Pink</u>.</p>  <p><CON7></p>	<table border="1"> <thead> <tr> <th>Status</th> <th>Result</th> <th>SVC Action</th> </tr> </thead> <tbody> <tr> <td rowspan="2">Normal</td> <td>12 V</td> <td>Go to the 4</td> </tr> <tr> <td>Other</td> <td>Change the PCB</td> </tr> </tbody> </table>	Status	Result	SVC Action	Normal	12 V	Go to the 4	Other	Change the PCB					
Status	Result	SVC Action													
Normal	12 V	Go to the 4													
	Other	Change the PCB													
4	<p>Check the <u>Red to Black</u>.</p> 	<table border="1"> <thead> <tr> <th>Status</th> <th>Result</th> <th>SVC Action</th> </tr> </thead> <tbody> <tr> <td rowspan="2">Normal</td> <td>12 V</td> <td>Go to the 5</td> </tr> <tr> <td>Other</td> <td>Change the LED Lamp</td> </tr> </tbody> </table>	Status	Result	SVC Action	Normal	12 V	Go to the 5	Other	Change the LED Lamp					
Status	Result	SVC Action													
Normal	12 V	Go to the 5													
	Other	Change the LED Lamp													
5	<p>Check the <u>Black to White</u>.</p> 	<table border="1"> <thead> <tr> <th>Status</th> <th>Result</th> <th>SVC Action</th> </tr> </thead> <tbody> <tr> <td rowspan="2">Closed</td> <td>0 ~ 2 V</td> <td>Explain to customer</td> </tr> <tr> <td>Other</td> <td>Change the Door S/W</td> </tr> <tr> <td rowspan="2">Open</td> <td>12 V</td> <td>Explain to customer</td> </tr> <tr> <td>Other</td> <td>Change the LED Lamp</td> </tr> </tbody> </table>	Status	Result	SVC Action	Closed	0 ~ 2 V	Explain to customer	Other	Change the Door S/W	Open	12 V	Explain to customer	Other	Change the LED Lamp
Status	Result	SVC Action													
Closed	0 ~ 2 V	Explain to customer													
	Other	Change the Door S/W													
Open	12 V	Explain to customer													
	Other	Change the LED Lamp													

9-5 Refrigerator room lamp doesn't work



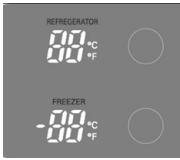

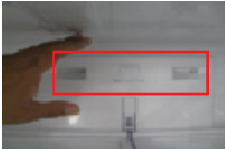
No	Checking flow	Result & SVC Action													
1	<p>Check the Refrigerator door switch.</p> 	<p>If feel sticky, Change the door s/w.</p>													
2	<p>Check the <u>door Switch resistance.</u></p> 	<table border="1"> <thead> <tr> <th>Status</th> <th>Result</th> <th>SVC Action</th> </tr> </thead> <tbody> <tr> <td rowspan="2">Normal</td> <td>0Ω</td> <td>Go to the 3</td> </tr> <tr> <td>Other</td> <td>Change door Switch</td> </tr> <tr> <td rowspan="2">Push S/W</td> <td>Infinity</td> <td>Go to the 3</td> </tr> <tr> <td>Other</td> <td>Change door Switch</td> </tr> </tbody> </table>	Status	Result	SVC Action	Normal	0Ω	Go to the 3	Other	Change door Switch	Push S/W	Infinity	Go to the 3	Other	Change door Switch
Status	Result	SVC Action													
Normal	0Ω	Go to the 3													
	Other	Change door Switch													
Push S/W	Infinity	Go to the 3													
	Other	Change door Switch													
3	<p>Check the <u>Red/yellow to Pink.</u></p>  <p><CON7></p>	<table border="1"> <thead> <tr> <th>Status</th> <th>Result</th> <th>SVC Action</th> </tr> </thead> <tbody> <tr> <td rowspan="2">Normal</td> <td>12 V</td> <td>Go to the 4</td> </tr> <tr> <td>Other</td> <td>Change the PCB</td> </tr> </tbody> </table>	Status	Result	SVC Action	Normal	12 V	Go to the 4	Other	Change the PCB					
Status	Result	SVC Action													
Normal	12 V	Go to the 4													
	Other	Change the PCB													
4	<p>Check the <u>Red to Black.</u></p> 	<table border="1"> <thead> <tr> <th>Status</th> <th>Result</th> <th>SVC Action</th> </tr> </thead> <tbody> <tr> <td rowspan="2">Normal</td> <td>12 V</td> <td>Go to the 5</td> </tr> <tr> <td>Other</td> <td>Change the LED Lamp</td> </tr> </tbody> </table>	Status	Result	SVC Action	Normal	12 V	Go to the 5	Other	Change the LED Lamp					
Status	Result	SVC Action													
Normal	12 V	Go to the 5													
	Other	Change the LED Lamp													
5	<p>Check the <u>Black to Blue.</u></p> 	<table border="1"> <thead> <tr> <th>Status</th> <th>Result</th> <th>SVC Action</th> </tr> </thead> <tbody> <tr> <td rowspan="2">Closed</td> <td>0 ~ 2 V</td> <td>Explain to customer</td> </tr> <tr> <td>Other</td> <td>Change the Door S/W</td> </tr> <tr> <td rowspan="2">Open</td> <td>12 V</td> <td>Explain to customer</td> </tr> <tr> <td>Other</td> <td>Change the LED Lamp</td> </tr> </tbody> </table>	Status	Result	SVC Action	Closed	0 ~ 2 V	Explain to customer	Other	Change the Door S/W	Open	12 V	Explain to customer	Other	Change the LED Lamp
Status	Result	SVC Action													
Closed	0 ~ 2 V	Explain to customer													
	Other	Change the Door S/W													
Open	12 V	Explain to customer													
	Other	Change the LED Lamp													



9-6 Poor cooling in Fresh food section

No	Checking flow	Result & SVC Action												
1	<p>Check the sensor resistance.</p>  <p><CON7></p> <p>※ The sensor is determined by the temperature. For example, 30kΩ indicates 32°F.</p>	<table border="1"> <thead> <tr> <th>Temperature</th> <th>Result</th> </tr> </thead> <tbody> <tr> <td>23°F / -5°C</td> <td>38 kΩ</td> </tr> <tr> <td>32°F / 0°C</td> <td>30 kΩ</td> </tr> <tr> <td>41°F / 5°C</td> <td>24 kΩ</td> </tr> <tr> <td>50°F / 10°C</td> <td>19.5 kΩ</td> </tr> <tr> <td>59°F / 15°C</td> <td>16 kΩ</td> </tr> </tbody> </table>	Temperature	Result	23°F / -5°C	38 kΩ	32°F / 0°C	30 kΩ	41°F / 5°C	24 kΩ	50°F / 10°C	19.5 kΩ	59°F / 15°C	16 kΩ
Temperature	Result													
23°F / -5°C	38 kΩ													
32°F / 0°C	30 kΩ													
41°F / 5°C	24 kΩ													
50°F / 10°C	19.5 kΩ													
59°F / 15°C	16 kΩ													
2	<p>Reset the unit and Input Test 1 Mode. (Push the button 1 time)</p>	 												
3	<p>Open the fresh food door and Check the air flow.</p> 	<table border="1"> <thead> <tr> <th>Status</th> <th>SVC Action</th> </tr> </thead> <tbody> <tr> <td>Windy</td> <td>Go to the 4</td> </tr> <tr> <td>No windy</td> <td>Check the R Fan motor Check the damper (Go to the 6)</td> </tr> </tbody> </table>	Status	SVC Action	Windy	Go to the 4	No windy	Check the R Fan motor Check the damper (Go to the 6)						
Status	SVC Action													
Windy	Go to the 4													
No windy	Check the R Fan motor Check the damper (Go to the 6)													
5	<p>Check the air temperature. Cold or not ?</p>	<table border="1"> <thead> <tr> <th>Status</th> <th>SVC Action</th> </tr> </thead> <tbody> <tr> <td>Cold</td> <td>Explain to customer</td> </tr> <tr> <td>Not cold</td> <td>Check the Compressor And sealed system</td> </tr> </tbody> </table>	Status	SVC Action	Cold	Explain to customer	Not cold	Check the Compressor And sealed system						
Status	SVC Action													
Cold	Explain to customer													
Not cold	Check the Compressor And sealed system													

No	Checking flow	Result & SVC Action									
6	<p data-bbox="298 431 703 491">Check the R Fan motor voltage. (3) (2) (1)</p>  <p data-bbox="488 821 597 846"><CON6></p>	<table border="1" data-bbox="885 442 1446 585"> <thead> <tr> <th data-bbox="885 442 1024 485">Point</th> <th data-bbox="1024 442 1198 485">Result</th> <th data-bbox="1198 442 1446 485">SVC Action</th> </tr> </thead> <tbody> <tr> <td data-bbox="885 485 1024 534">(1) ~ (2)</td> <td data-bbox="1024 485 1198 534">Below 12 V</td> <td data-bbox="1198 485 1446 534">Change the PCB</td> </tr> <tr> <td data-bbox="885 534 1024 585">(1) ~ (3)</td> <td data-bbox="1024 534 1198 585">0 or 5 V</td> <td data-bbox="1198 534 1446 585">Change the motor</td> </tr> </tbody> </table>	Point	Result	SVC Action	(1) ~ (2)	Below 12 V	Change the PCB	(1) ~ (3)	0 or 5 V	Change the motor
Point	Result	SVC Action									
(1) ~ (2)	Below 12 V	Change the PCB									
(1) ~ (3)	0 or 5 V	Change the motor									

9-7 Poor cooling in Freezer compartment

No	Checking flow	Result & SVC Action																
1	<p>Check the sensor resistance.</p>  <p><CON7></p> <p>※ The sensor is determined by the temperature. For example, 23kΩ indicates -4°F.</p>	<table border="1"> <thead> <tr> <th data-bbox="943 442 1159 491">(1) To (2)</th> <th data-bbox="1159 442 1370 491">Result</th> </tr> </thead> <tbody> <tr> <td data-bbox="943 491 1159 540">-22°F / -30°C</td> <td data-bbox="1159 491 1370 540">40 kΩ</td> </tr> <tr> <td data-bbox="943 540 1159 589">-13°F / -25°C</td> <td data-bbox="1159 540 1370 589">30 kΩ</td> </tr> <tr> <td data-bbox="943 589 1159 638">-4°F / -20°C</td> <td data-bbox="1159 589 1370 638">23 kΩ</td> </tr> <tr> <td data-bbox="943 638 1159 687">5°F / -15°C</td> <td data-bbox="1159 638 1370 687">17 kΩ</td> </tr> <tr> <td data-bbox="943 687 1159 736">14°F / -10°C</td> <td data-bbox="1159 687 1370 736">13 kΩ</td> </tr> <tr> <td data-bbox="943 736 1159 785">23°F / -5°C</td> <td data-bbox="1159 736 1370 785">10 kΩ</td> </tr> <tr> <td data-bbox="943 785 1159 834">32°F / 0°C</td> <td data-bbox="1159 785 1370 834">8 kΩ</td> </tr> </tbody> </table>	(1) To (2)	Result	-22°F / -30°C	40 kΩ	-13°F / -25°C	30 kΩ	-4°F / -20°C	23 kΩ	5°F / -15°C	17 kΩ	14°F / -10°C	13 kΩ	23°F / -5°C	10 kΩ	32°F / 0°C	8 kΩ
(1) To (2)	Result																	
-22°F / -30°C	40 kΩ																	
-13°F / -25°C	30 kΩ																	
-4°F / -20°C	23 kΩ																	
5°F / -15°C	17 kΩ																	
14°F / -10°C	13 kΩ																	
23°F / -5°C	10 kΩ																	
32°F / 0°C	8 kΩ																	
2	<p>Reset the unit and Input Test 1 Mode. (Push the button 1 time)</p>	 																
3	<p>Open the freezer door and Check the air flow.</p> 	<table border="1"> <thead> <tr> <th data-bbox="927 1183 1086 1232">Status</th> <th data-bbox="1086 1183 1406 1232">SVC Action</th> </tr> </thead> <tbody> <tr> <td data-bbox="927 1232 1086 1281">Windy</td> <td data-bbox="1086 1232 1406 1281">Go to the 4</td> </tr> <tr> <td data-bbox="927 1281 1086 1330">No windy</td> <td data-bbox="1086 1281 1406 1330">Check the F Fan motor</td> </tr> </tbody> </table>	Status	SVC Action	Windy	Go to the 4	No windy	Check the F Fan motor										
Status	SVC Action																	
Windy	Go to the 4																	
No windy	Check the F Fan motor																	
4	<p>Check the air temperature. Cold or not ?</p>	<table border="1"> <thead> <tr> <th data-bbox="927 1513 1086 1561">Status</th> <th data-bbox="1086 1513 1406 1561">SVC Action</th> </tr> </thead> <tbody> <tr> <td data-bbox="927 1561 1086 1610">Cold</td> <td data-bbox="1086 1561 1406 1610">Explain to customer</td> </tr> <tr> <td data-bbox="927 1610 1086 1683">Not cold</td> <td data-bbox="1086 1610 1406 1683">Check the Compressor And sealed system</td> </tr> </tbody> </table>	Status	SVC Action	Cold	Explain to customer	Not cold	Check the Compressor And sealed system										
Status	SVC Action																	
Cold	Explain to customer																	
Not cold	Check the Compressor And sealed system																	

No	Checking flow	Result & SVC Action									
6	<p>Check the <u>Fan motor</u>. Rotate fan using your hand. If it feels sticky, change the motor. (cause of ice or rust inside of motor).</p> 	<table border="1"> <thead> <tr> <th>Point</th> <th>Result</th> <th>SVC Action</th> </tr> </thead> <tbody> <tr> <td>Motor</td> <td>Sticky</td> <td>Change the motor</td> </tr> </tbody> </table>	Point	Result	SVC Action	Motor	Sticky	Change the motor			
Point	Result	SVC Action									
Motor	Sticky	Change the motor									
7	<p>Check the <u>F Fan motor voltage</u>.</p>  <p>(3)(2)(1) <CON7></p>	<table border="1"> <thead> <tr> <th>Point</th> <th>Result</th> <th>SVC Action</th> </tr> </thead> <tbody> <tr> <td>(1) ~ (2)</td> <td>Below 12 V</td> <td>Change the PCB</td> </tr> <tr> <td>(1) ~ (3)</td> <td>0 or 5 V</td> <td>Change the motor</td> </tr> </tbody> </table>	Point	Result	SVC Action	(1) ~ (2)	Below 12 V	Change the PCB	(1) ~ (3)	0 or 5 V	Change the motor
Point	Result	SVC Action									
(1) ~ (2)	Below 12 V	Change the PCB									
(1) ~ (3)	0 or 5 V	Change the motor									

10. Reference

10-1 TEST MODE and Removing TPA

1. How to make TEST MODE

If you push the test button on the Main PCB, the refrigerator will be enter the TEST MODE.



Main PCB

* 1 time : Comp / Damper / All FAN on
(All things displayed)



* 2 times : Damper closed
(22 22 displayed)



* 3 times : Forced defrost mode
(33 33 displayed)



2. How to remove Terminal Position Assurance (TPA)

<AC TPA>

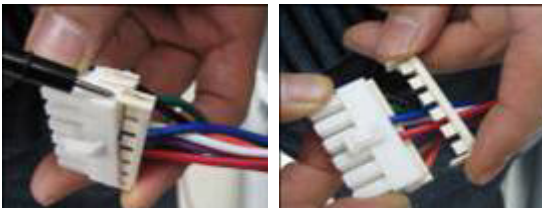

<DC TPA>

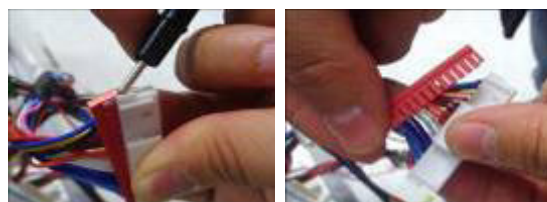

※ After measure the values, you should put in the TPA again.

10-2 TEMPERATRUE CHART - FREEZER AND ICING SENSOR

TEMP	RESISTANCE	VOLTAGE
-39°F (-40°C)	73.29 kΩ	4.09 V
-30°F (-35°C)	53.63 kΩ	3.84 V
-30°F (-21°C)	39.66 kΩ	3.55 V
-13°F (-25°C)	29.62 kΩ	3.23 V
-4°F (-20°C)	22.33 kΩ	2.89 V
5°F (-15°C)	16.99 kΩ	2.56 V
14°F (-10°C)	13.05 kΩ	2.23 V
23°F (-5°C)	10.10 kΩ	1.92 V
32°F (0°C)	7.88 kΩ	1.63 V
41°F (+5°C)	6.19 kΩ	1.38 V
50°F (+10°C)	4.91 kΩ	1.16 V
59°F (+15°C)	3.91 kΩ	0.97 V
68°F (+20°C)	3.14 kΩ	0.81 V
77°F (+25°C)	2.54 kΩ	0.67 V
86°F (+30°C)	2.07 kΩ	0.56 V
95°F (+35°C)	1.69 kΩ	0.47 V
104°F (+40°C)	1.39 kΩ	0.39 V

10-3 TEMPERATRUE CHART - REFRIGERATOR AND DEFROST SENSOR

TEMP	RESISTANCE	VOLTAGE
-39°F (-40°C)	225.1 kΩ	4.48 V
-30°F (-35°C)	169.8 kΩ	4.33 V
-30°F (-21°C)	129.3 kΩ	4.16 V
-13°F (-25°C)	99.30 kΩ	3.95 V
-4°F (-20°C)	76.96 kΩ	3.734 V
5°F (-15°C)	60.13 kΩ	3.487 V
14°F (-10°C)	47.34 kΩ	3.22 V
23°F (-5°C)	37.55 kΩ	2.95 V
32°F (0°C)	30 kΩ	2.67 V
41°F (+5°C)	24.13 kΩ	2.40 V
50°F (+10°C)	19.53 kΩ	2.14 V
59°F (+15°C)	15.91 kΩ	1.89 V
68°F (+20°C)	13.03 kΩ	1.64 V
77°F (+25°C)	10.74 kΩ	1.45 V
86°F (+30°C)	8.89 kΩ	1.27 V
95°F (+35°C)	7.40 kΩ	1.10 V
104°F (+40°C)	6.20 kΩ	0.96 V

Compressor Troubleshooting

Step 1) Open PCB cover





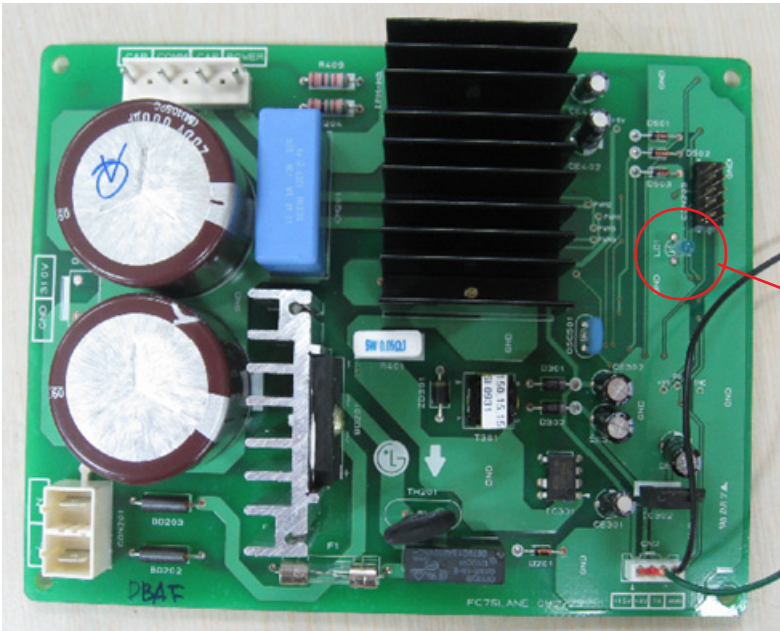

Step 2) Check for blinking frequency of LED, PCB



If compressor is normal, it does not blink
: Refer to the next page to find out what actions to take according to how many times LED blink

Actions to take according to Led blinking frequency

No	LED operating condition	Cause	Service guideline
1	<p>LED two - time repetiton</p>  <p>..on - on - off - on - on - off - on - on - off ..repeating</p>	PCB part defect (piston overrun)	<ol style="list-style-type: none"> 1.After resetting power, check if it is running normal 2.If the same symptom arises after the first action, replace PCB
2	<p>LED four - time repetiton</p>  <p>..on - on - on - on - off - on - on - on - on - off ..repeating</p>	outlet clogging	<ol style="list-style-type: none"> 1.After resetting power, check if it is running normal 2.If the same symptom arises after the first action, replace PCB 3.If the same symptom arises after the second action, replace compressor
3	<p>LED five - time repetiton</p>  <p>..on - on - on - on - on - off - on - on - on - on - on - off ..repeating</p>	piston constraint	<ol style="list-style-type: none"> 1. After resetting power, check if it is running normal 2. If the same symptom arises after the first action, replace PCB 3. If the same symptom arises after the second action, replace compressor
4	<p>LED six - time repetiton</p>  <p>..on - on - on - on - on - on - off - on - on - on - on - on - on - off ..repeating</p>	circuit overcurrent error	<ol style="list-style-type: none"> 1. After resetting power, check if it is running normal <p>If the same symptom arises after the first action, replace PCB</p> <p>If the same symptom arises after the second action, replace compressor</p>
5	<p>LED seven- time repetiton</p>  <p>..on - on - on - on - on - on - on - off - on - on - on - on - on - on - on - off ..repeating</p>	PCB part defect (IPM)	<ol style="list-style-type: none"> 1.After resetting power, check if it is running normal 2. If the same symptom arises after the first action, replace PCB

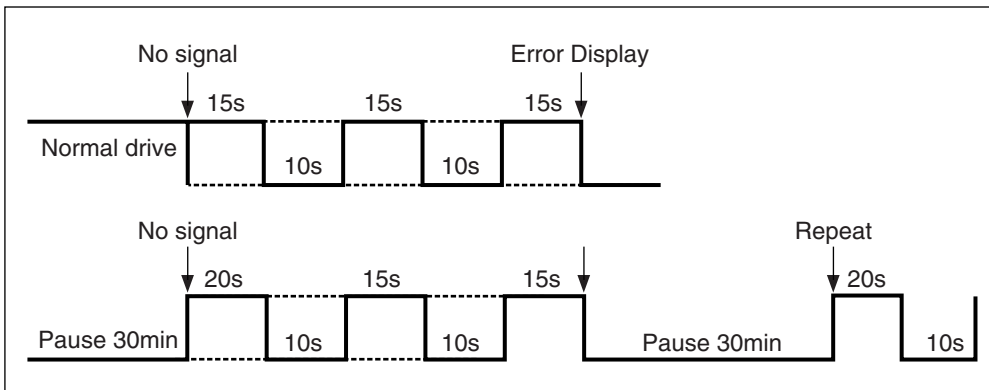

10-4 How to check the Fan-Error

After sending a signal to the fan, the MICOM checks the BLDC fan motor's lock status. If there is no feedback signal from the BLDC fan, the fan motor stops for 10 seconds and then is powered again for 15 seconds. To determine that there is a fan motor malfunction, this process is repeated 3 times. If the fan motor is determined to be defective, the error code will be shown in the display for 30 minutes. At this point, the process will be repeated until the fan motor operates normally. If normal operation is achieved, the error display is erased and the MICOM is reset automatically.



11. COMPONENT TESTING INFORMATION

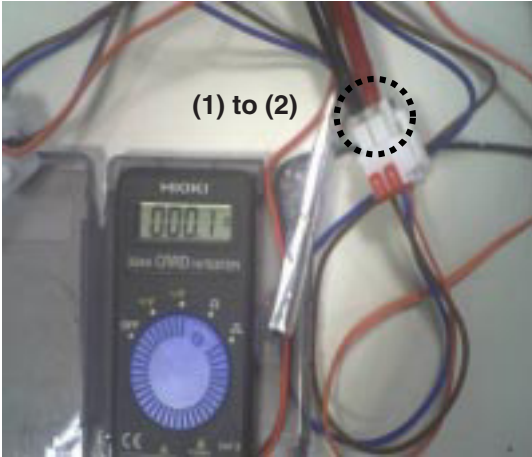

11-1 Defrost Controller Assembly

<p>Function</p>	<p>The controller assembly is made up of two different kinds of parts. The fuse and the sensor. To determine if these parts are defective, check for resistance. The fuse will cut power to the defrost heater at very high temperatures.</p>									
<p>How to Measure (Fuse-M)</p>		<p>Set a ohmmeter to the 2 housing pin. Measure the 2 pin connected to Fuse-M. If the ohmmeter indicate below 0.1ohm fuse-m is a good condition, But if infinite the part is bad.</p>								
<p>How to Measure (Sensor)</p>		<p>Set a ohmmeter to The 2housing pin. Measure the 2 pin connected to Sensor. If the ohmmeter indicate 11kΩ (at room temperature) Sensor is good. When check the ohm at other temperatures Check the sensor manual.</p>								
<p>Standard</p>	<p style="text-align: center;">Fuse-M (at all temperature)</p> <table border="1" style="margin-left: auto; margin-right: auto;"> <thead> <tr> <th>Test Point</th> <th>Ressult</th> </tr> </thead> <tbody> <tr> <td>(1) to (2)</td> <td>0 ~ 0.1Ω</td> </tr> </tbody> </table>	Test Point	Ressult	(1) to (2)	0 ~ 0.1Ω	<p style="text-align: center;">Sensor (at room temperature)</p> <table border="1" style="margin-left: auto; margin-right: auto;"> <thead> <tr> <th>Test Point</th> <th>Ressult</th> </tr> </thead> <tbody> <tr> <td>(1) to (2)</td> <td>11Ω</td> </tr> </tbody> </table>	Test Point	Ressult	(1) to (2)	11Ω
Test Point	Ressult									
(1) to (2)	0 ~ 0.1Ω									
Test Point	Ressult									
(1) to (2)	11Ω									

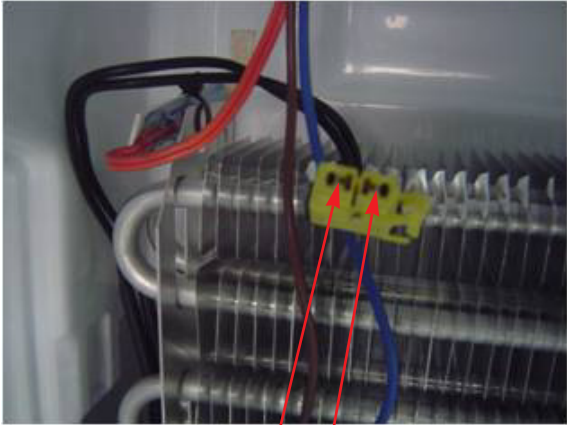

11-2 Sheath Heater (Freezer Room)

Function	Sheath heater is the part for defrost. All heating wire is connected to only one line. So we can decide part is defective or not when we check the resistance.				
How to Measure	<div style="display: flex; justify-content: space-around; align-items: flex-start;">   </div> <p style="text-align: center;">(1) (2)</p> <p>Set a ohmmeter connect to The housing pins. Measure the pins connected to Sheath Heater. If the ohmmeter indicates $(V^{\circ}V)/Watt=R$ is on a good condition, ex) watt=350W, voltage=115V $R=(115^{\circ}115)/350=38\Omega$ Infinitive value implies sheath heater is disconnected.</p>				
Standard	<p style="text-align: center;">Sheath heater (at all temperature)</p> <table border="1" style="margin-left: auto; margin-right: auto;"> <thead> <tr> <th>Test Point</th> <th>Ressult</th> </tr> </thead> <tbody> <tr> <td>(1) to (2)</td> <td>41.8 ~ 46.2</td> </tr> </tbody> </table>	Test Point	Ressult	(1) to (2)	41.8 ~ 46.2
Test Point	Ressult				
(1) to (2)	41.8 ~ 46.2				

11-2 Sheath Heater (Refrigerator Room)

<p>Function</p>	<p>Sheath heater is the part for defrost. All heating wire is connected to only one line. So we can decide part is defective or not when we check the resistance.</p>				
<p>How to Measure</p>	<div style="display: flex; justify-content: space-around; align-items: center;">   </div> <p style="text-align: center;">(1) (2)</p> <p>Set a ohmmeter connect to The housing pins. Measure the pins connected to Sheath Heater. If the ohmmeter indicates $(V^2 \div W) = R$ is on a good condition, ex) watt=350W, voltage=115V $R = (115^2 \div 350) = 38 \Omega$ Infinitive value implies sheath heater is disconnected.</p>				
<p>Standard</p>	<p style="text-align: center;">Sheath heater (at all temperature)</p> <table border="1" style="margin-left: auto; margin-right: auto;"> <thead> <tr> <th>Test Point</th> <th>Result</th> </tr> </thead> <tbody> <tr> <td>(1) to (2)</td> <td>78.6 ~ 86.8</td> </tr> </tbody> </table>	Test Point	Result	(1) to (2)	78.6 ~ 86.8
Test Point	Result				
(1) to (2)	78.6 ~ 86.8				

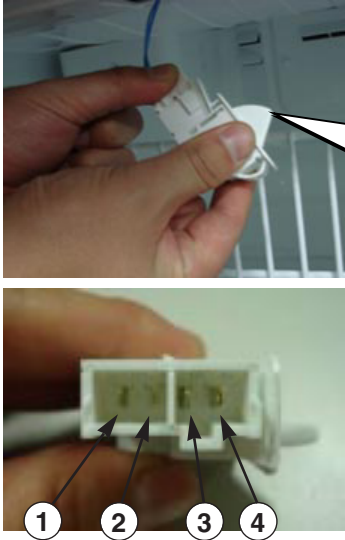
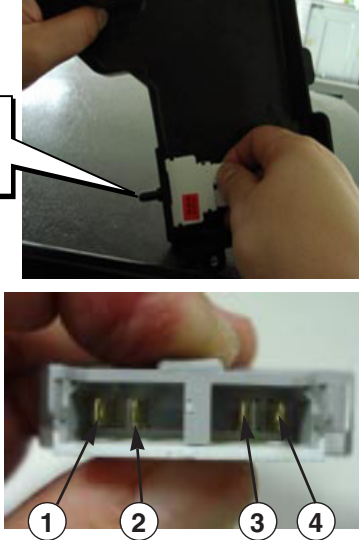
11-4 Door Switch

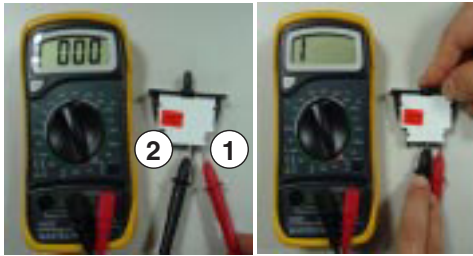
<p>Function</p>	<p>The switch senses if the door is open or closed.</p> <ul style="list-style-type: none"> - When the door open, lamp on. - When the door open, the switch give information to Micom. <p>When the door open, internal contact operate on and off moving plunger of door switch up and down.</p>						
<p>How to Measure</p>	<div style="display: flex; justify-content: space-around;"> <div style="text-align: center;"> <p><Switch, Freezer></p>  </div> <div style="text-align: center;"> <p><Switch, Refrigerator></p>  </div> </div> <div style="display: flex; justify-content: space-around; margin-top: 20px;"> <div style="text-align: center;">  <p>Beep</p> </div> <div style="text-align: center;">  <p>Beep</p> </div> </div> <p>Check the resistance between connectors 1, 2 and 3, 4 .It means check whether or not applying an electric current. If there is resistance, the switch is good.</p>						
<p>Standard</p>	<table border="1" style="margin-left: auto; margin-right: auto;"> <thead> <tr> <th colspan="2" style="text-align: center;">Multimeter beep – Switch F,R</th> </tr> </thead> <tbody> <tr> <td style="text-align: center;">Nomal</td> <td style="text-align: center;">Push the button(Plunger)</td> </tr> <tr> <td style="text-align: center;">Beep or 0Ω</td> <td style="text-align: center;">None (∞ Ω)</td> </tr> </tbody> </table>	Multimeter beep – Switch F,R		Nomal	Push the button(Plunger)	Beep or 0Ω	None (∞ Ω)
Multimeter beep – Switch F,R							
Nomal	Push the button(Plunger)						
Beep or 0Ω	None (∞ Ω)						

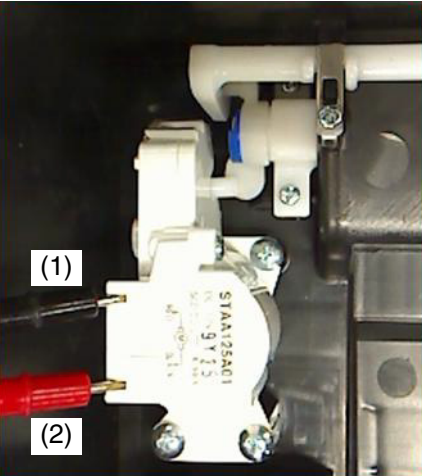

11-5 Dispenser DC Motor

Function	- Dispenser DC Motor : When customer push the dispenser button, Pull duct door and abstract from ice bank.						
How to Measure	<div style="text-align: center;">  <p>Dispenser DC Motor</p> </div>						
Standard	<table border="1" style="margin-left: auto; margin-right: auto;"> <thead> <tr> <th colspan="2" style="text-align: center;">Dispenser DC Motor</th> </tr> <tr> <th style="text-align: center;">Test Points</th> <th style="text-align: center;">Result</th> </tr> </thead> <tbody> <tr> <td style="text-align: center;">(1) to (2)</td> <td style="text-align: center;">9.9 ~ 12.1 Ω</td> </tr> </tbody> </table>	Dispenser DC Motor		Test Points	Result	(1) to (2)	9.9 ~ 12.1 Ω
Dispenser DC Motor							
Test Points	Result						
(1) to (2)	9.9 ~ 12.1 Ω						

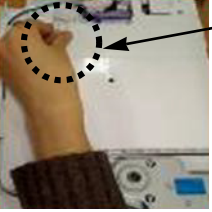
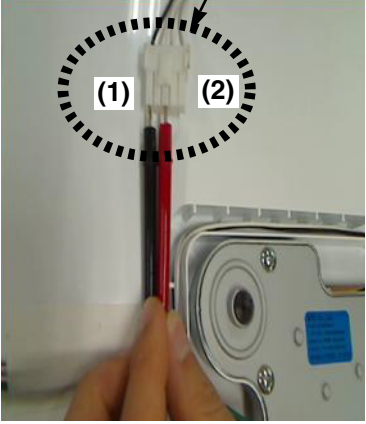
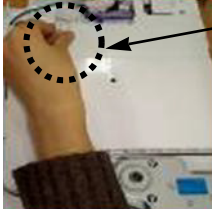
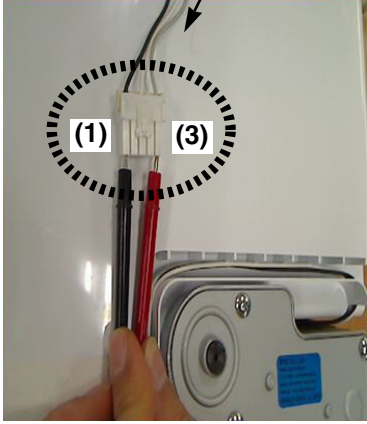
11-6 AC Motor ASSEMBLY

<p>Function</p>	<p>The motor in the door pushed the ice into the dispenser.</p>									
<p>How to Measure</p>	<p>< In-door Motor ></p>  <p>① Separate the housing.</p>  <p>② Measure the resistance between (1) and (2)</p>	<p>< In-door Motor ></p>  <p>① Separate the housing.</p>  <p>② Measure the resistance between (1) and (3)</p> <p>Check the resistance between connectors (In-door motor 1, 2) and (In-door motor 1, 3). It means check whether or not applying an Electric current. If there is resistance, it means the geared motor or solenoid is not inferiority</p>								
<p>Standard</p>	<p style="text-align: center;">Geared Motor</p> <table border="1" style="margin-left: auto; margin-right: auto;"> <thead> <tr> <th>Test Points</th> <th>Result</th> </tr> </thead> <tbody> <tr> <td>(1) to (2)</td> <td>31.1 ~ 42.09Ω</td> </tr> </tbody> </table>	Test Points	Result	(1) to (2)	31.1 ~ 42.09Ω	<p style="text-align: center;">Cube Solenoid</p> <table border="1" style="margin-left: auto; margin-right: auto;"> <thead> <tr> <th>Test Points</th> <th>Result</th> </tr> </thead> <tbody> <tr> <td>(1) to (3)</td> <td>31.1 ~ 42.09Ω</td> </tr> </tbody> </table>	Test Points	Result	(1) to (3)	31.1 ~ 42.09Ω
Test Points	Result									
(1) to (2)	31.1 ~ 42.09Ω									
Test Points	Result									
(1) to (3)	31.1 ~ 42.09Ω									

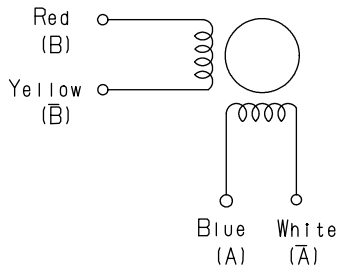
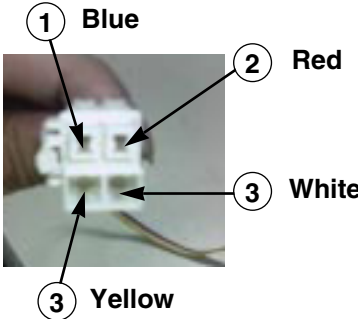
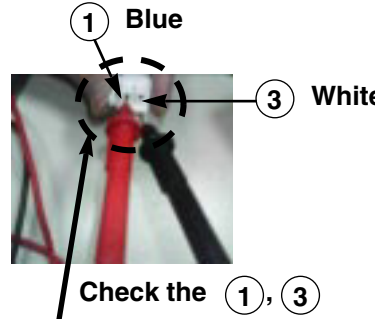

11-7 Damper

<p>Function</p>	<p>The damper supplies cold air from the freezer to the chill room using the damper plate. The chill room is colder when the damper plate is open. When the damper is closed the chill rooms temperature will rise.</p>																													
<p>How to Measure</p>	<div style="border: 1px dashed black; padding: 10px; margin-bottom: 10px;"> <p>Table(1): 결선도(Wiring)</p>  <p>Table(2): 2-2상 여자순서(CW Rotation)</p> <table border="1" style="width: 100%; border-collapse: collapse; text-align: center;"> <thead> <tr> <th rowspan="2">Housing No. & L/Wire Color</th> <th colspan="4">Step</th> </tr> <tr> <th>1</th> <th>2</th> <th>3</th> <th>4</th> </tr> </thead> <tbody> <tr> <td>1- Blue (A)</td> <td>+</td> <td>-</td> <td>-</td> <td>+</td> </tr> <tr> <td>2- Red (B)</td> <td>+</td> <td>+</td> <td>-</td> <td>-</td> </tr> <tr> <td>3- White(A)</td> <td>-</td> <td>+</td> <td>+</td> <td>-</td> </tr> <tr> <td>4- Yellow(B)</td> <td>-</td> <td>-</td> <td>+</td> <td>+</td> </tr> </tbody> </table> </div> <p style="text-align: center;">< Damper Circuit ></p> <div style="display: flex; justify-content: space-around;"> <div style="text-align: center;">  <p>Check the ②, ④</p> </div> <div style="text-align: center;">  <p>Check the ①, ③</p> </div> </div> <p style="text-align: center;">< extension ></p> <div style="display: flex; justify-content: space-around;"> <div style="text-align: center;">  <p>Check the ②, ④</p> </div> <div style="text-align: center;">  <p>Check the ①, ③</p> </div> </div> <p>Check to see if there is electrical current, if there is resistance the damper is good.</p>	Housing No. & L/Wire Color	Step				1	2	3	4	1- Blue (A)	+	-	-	+	2- Red (B)	+	+	-	-	3- White(A)	-	+	+	-	4- Yellow(B)	-	-	+	+
Housing No. & L/Wire Color	Step																													
	1	2	3	4																										
1- Blue (A)	+	-	-	+																										
2- Red (B)	+	+	-	-																										
3- White(A)	-	+	+	-																										
4- Yellow(B)	-	-	+	+																										
<p>Standard</p>	<table border="1" style="width: 100%; border-collapse: collapse;"> <thead> <tr> <th colspan="2" style="text-align: left;">Damper</th> <th colspan="2"></th> </tr> <tr> <th style="width: 25%;">Test Points</th> <th style="width: 25%;">Result</th> <th style="width: 25%;">Test Points</th> <th style="width: 25%;">Result</th> </tr> </thead> <tbody> <tr> <td>Red and Yellow</td> <td>373 ~ 456Ω</td> <td>Blue and White</td> <td>373 ~ 456Ω</td> </tr> </tbody> </table>	Damper				Test Points	Result	Test Points	Result	Red and Yellow	373 ~ 456Ω	Blue and White	373 ~ 456Ω																	
Damper																														
Test Points	Result	Test Points	Result																											
Red and Yellow	373 ~ 456Ω	Blue and White	373 ~ 456Ω																											

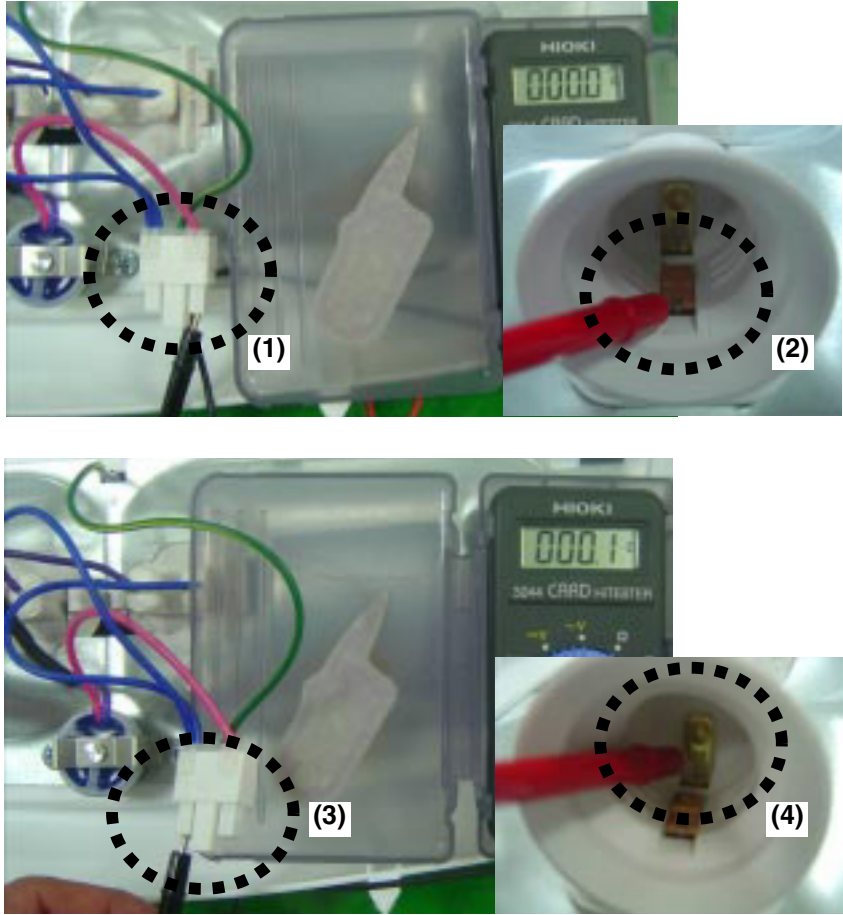
11-8 Lamp Socket

<p>Function</p>	<p>The lamp socket connect cover lamp assembly to lamp. The lamp socket fix lamp and unite lamp and cover lamp assembly. The lamp socket supply electric source to lamp also.</p>				
<p>How to Measure</p>	<div style="text-align: center;">  </div> <p>Check the resistance between connector of housing and connector of lamp socket. It means check whether or not applying an electric current. If there is resistance it means the lamp socket is good.</p>				
<p>Standard</p>	<table border="1" style="margin-left: auto; margin-right: auto;"> <thead> <tr> <th data-bbox="388 1630 734 1672">Test Points</th> <th data-bbox="734 1630 976 1672">Result</th> </tr> </thead> <tbody> <tr> <td data-bbox="388 1672 734 1721">(1) to (2) and (3) to (4)</td> <td data-bbox="734 1672 976 1721">0Ω</td> </tr> </tbody> </table>	Test Points	Result	(1) to (2) and (3) to (4)	0Ω
Test Points	Result				
(1) to (2) and (3) to (4)	0Ω				

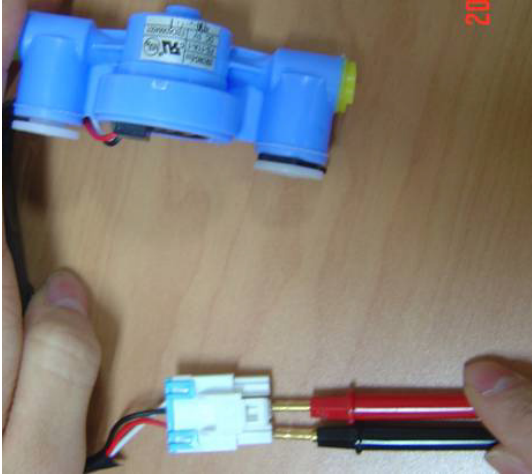
11-9 Flow Sensor

<p>Function</p>	<p>Flow Sensor (in machine room) Count the water quantity from city water to water filter in refrigerator</p>					
<p>How to Measure</p>	<div style="display: flex; justify-content: space-around;">   </div> <p style="text-align: center;">Flow Sensor (in machine room)</p>					
<p>Standard</p>	<table border="1" style="margin-left: auto; margin-right: auto;"> <thead> <tr> <th>Test Points</th> <th>Result</th> </tr> </thead> <tbody> <tr> <td>Red wire to Black wire</td> <td>4 ~ 30 kΩ</td> </tr> </tbody> </table>		Test Points	Result	Red wire to Black wire	4 ~ 30 kΩ
Test Points	Result					
Red wire to Black wire	4 ~ 30 kΩ					

12-1 Check A

- There is PC Board located in the PCB case.
The control driver is PC board for the compressor.
- This step shows the source voltage of the driver PC board.

Step1. Open PCB Cover



Step2. Check Driver PCB

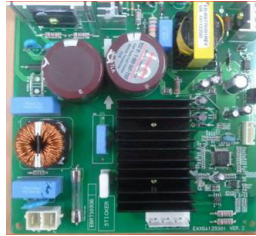

* Driver PCB located in machine room.

IPM Output check

- Measure the voltage between the POWER and COMM pins of the connector as shown below.

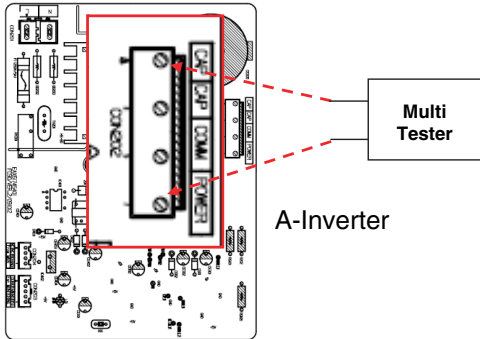

Check to make sure compressor is receiving voltage from IPM

- In order to determine whether the compressor is operating normally, check the output voltage during the refrigeration cycle.
- After initial power-up, when the compressor begins to operate, wait 10 minutes before checking.
- The compressor is operating normally if the voltage is greater than 80V.

12-2 Check B

B1. LED blinks once, then repeats (FCT0 Fault: A-Inverter)

Protection Logic



Blink OFF Blink OFF

- Purpose: Detecting motor current and voltage error
- Check voltage at **point A** (Motor Voltage), **point B** (Motor Current) and **Point C** (Capacitor Voltage) when **compressor is off**.
- Spec: **Points A, B, & C 2.5V ± 0.3V**

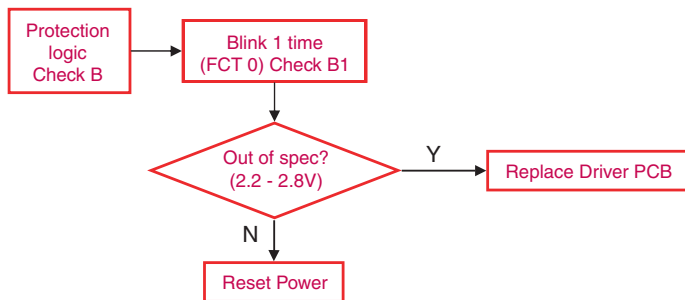

B2. LED blinks two times, then repeats (Stroke Trip: A & E Inverters)

Protection Logic



Blink Blink OFF Blink Blink OFF

- Purpose: Prevent abnormally long piston strokes.
- Case 1. If compressor doesn't work and LED blinks - Cause: Possibly harness from compressor to PCB might be defective.
- Case 2. If compressor works intermittently and LED blinks - Cause: Condenser Fan or Freezer Fan is not running. Sealed system problem such as moisture restriction, restriction at capillary tube or refrigerant leak.
- Logic: Compressor is forced to off and then tries to restart after 1 minute.

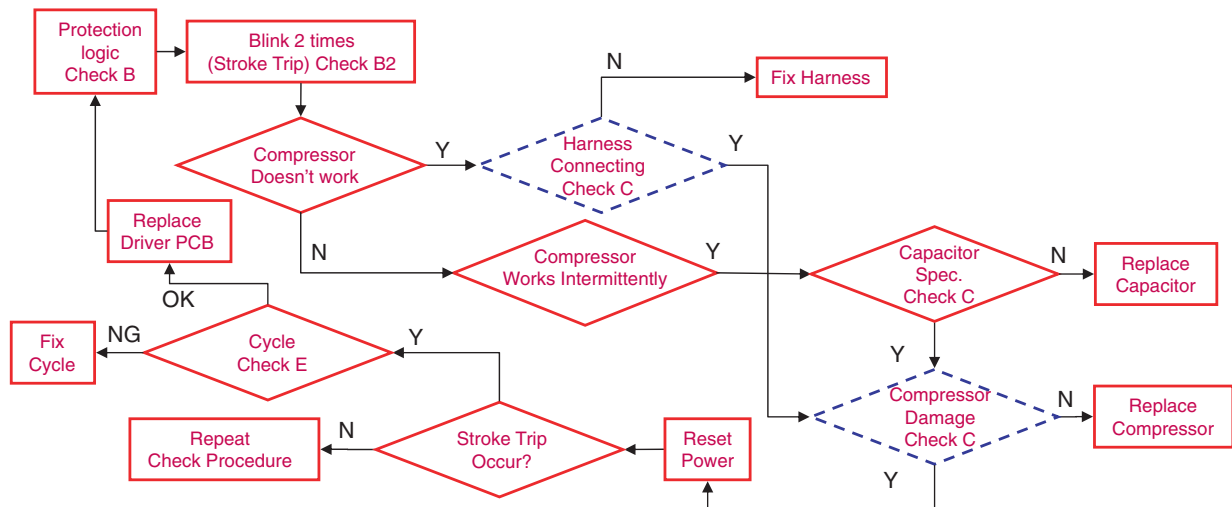

B5. LED blinks seven times, then repeats (IPM Fault: A & E Inverters)



Blink Blink Blink Blink Blink Blink OFF

- Purpose: Prevent high current due to IPM Short
- Cause: Damaged IPM (Dead Short)
- Test for a dead short at **Point A** with a VOM.
- Logic: Compressor is forced off and tries to restart in 20 seconds.

Protection Logic

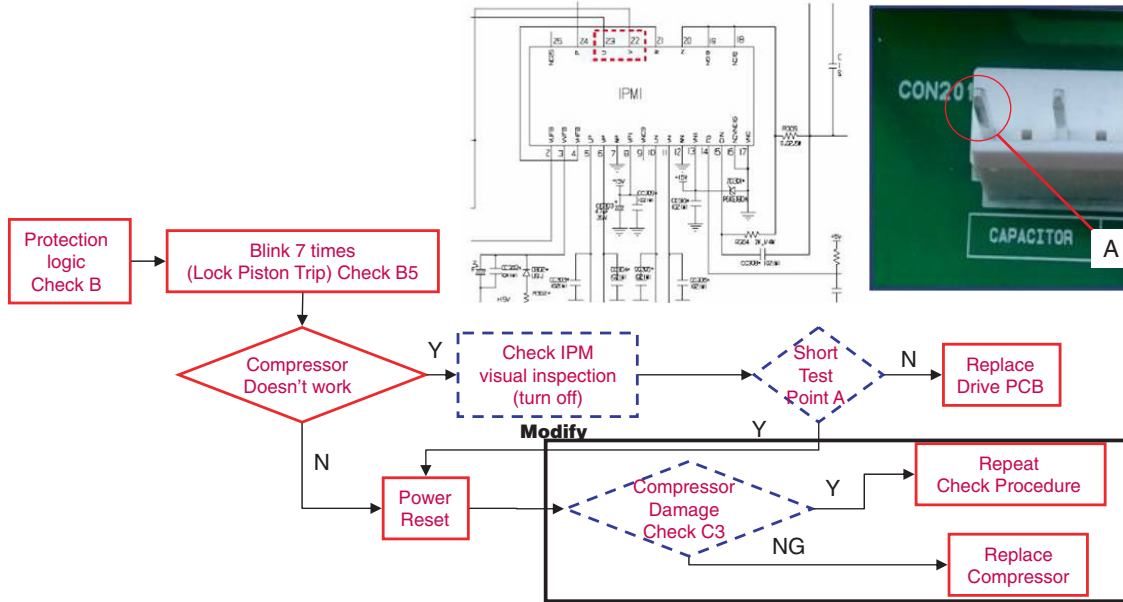
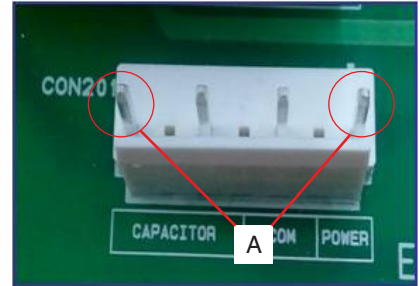

12-3 Check C

- C1. Harness Connection Check
- C2. Capacitor Specifications
- C3. Compressor Check

Check Process

- Step 1. Power off. Step 2. Check capacitor spec. (table1). Step3. Check resistance of point A
- Step 4. Check wire harness (INF ohm). Step 5. Check resistance at point B. Step 6. Point D.

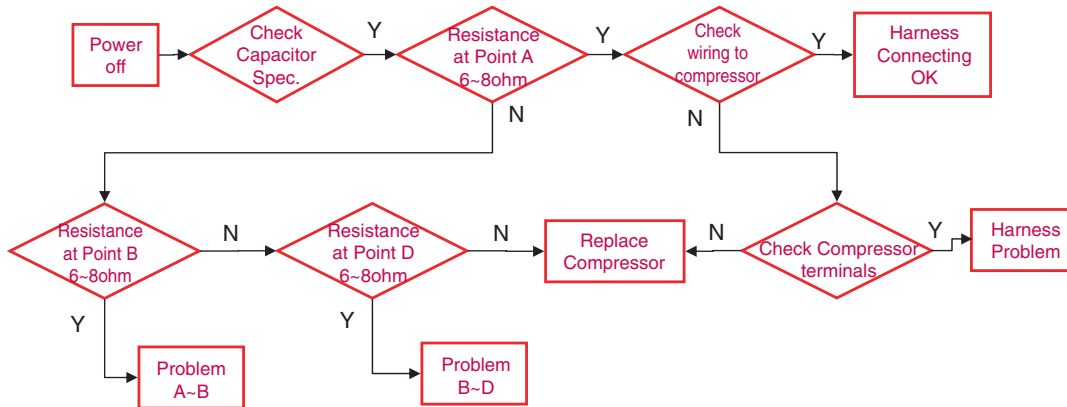

Caution : Turn off power during check C

- Measure the resistance at each point except point C
- Dead short check: measure the resistance between power line in compressor and earth ground in refrigerator (Inf. Ohm)

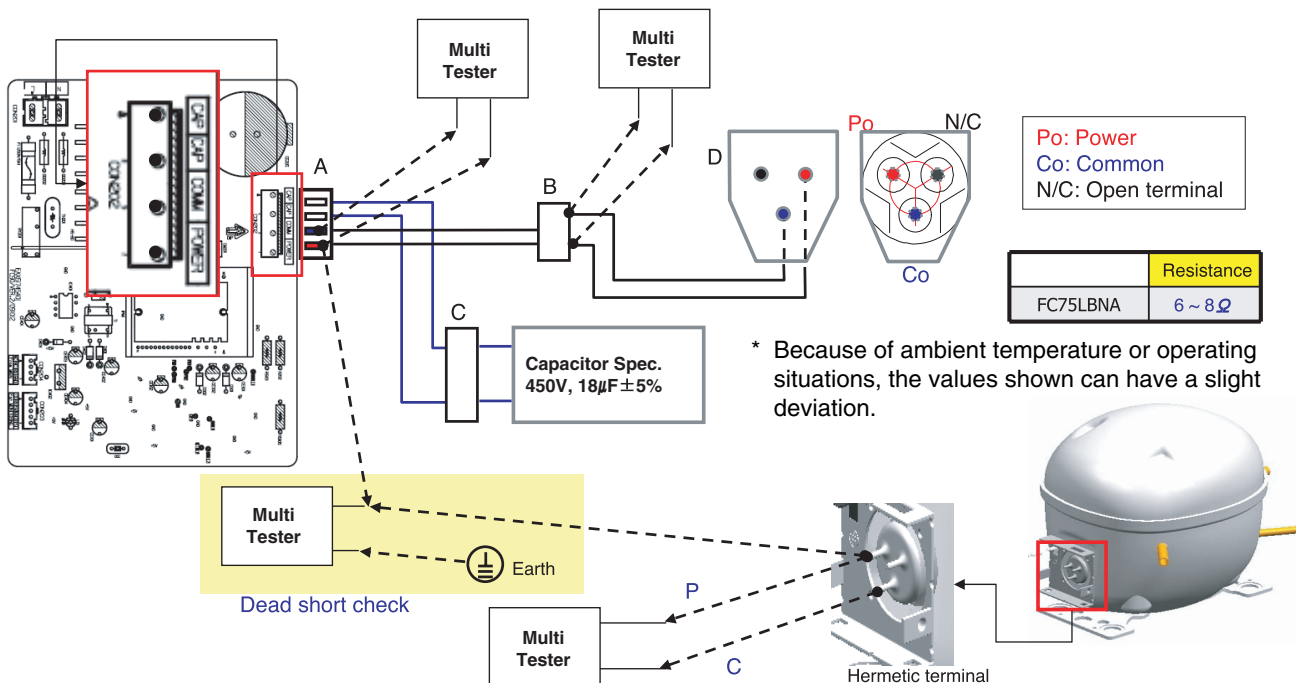

12-4 Check D

D1. Activate Protection logic

Cycle check with protection logic

- We have to check Condenser fan and Freezer fan before performing Check D
- Locked Piston, Current trip and stroke trip can be activated by other problems than the driver or compressor.

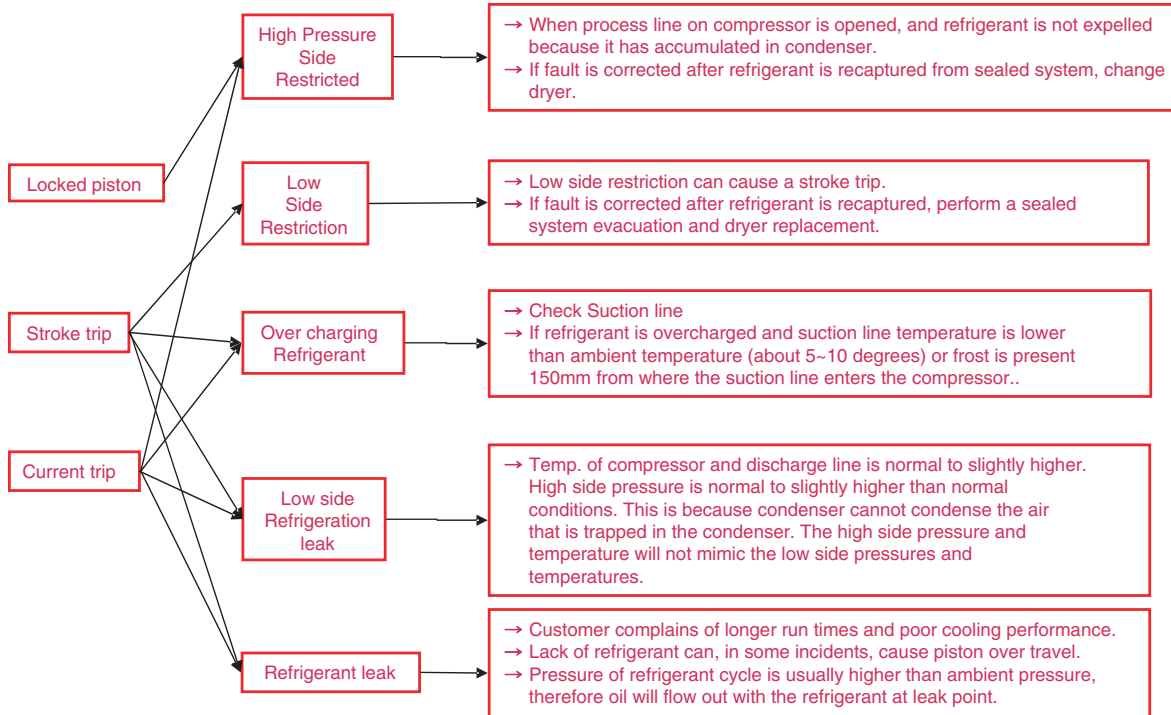

D2. sealed system diagnosis

- Check as follows;

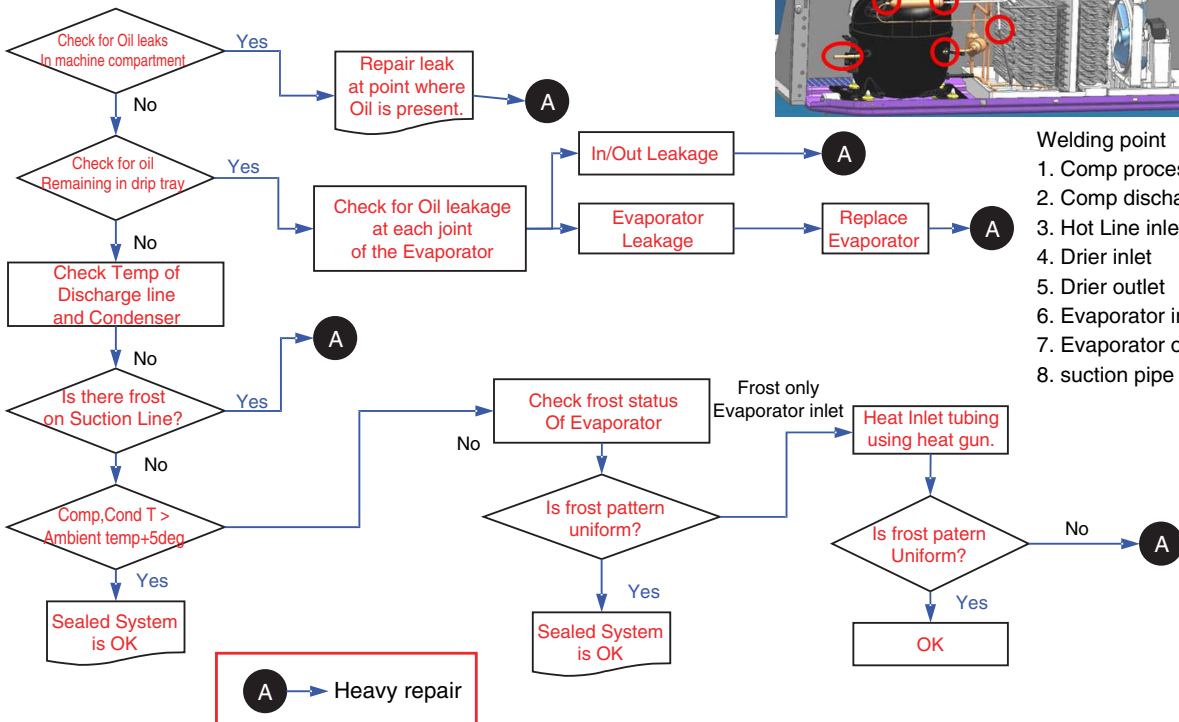

Compressor Troubleshooting

⚠ WARNING HIGH VOLTAGE





Step 1) Open PCB cover

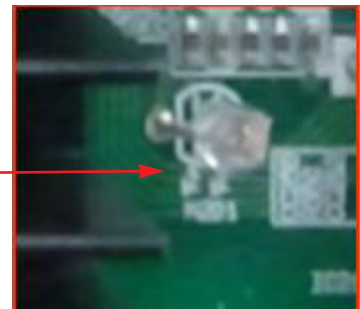
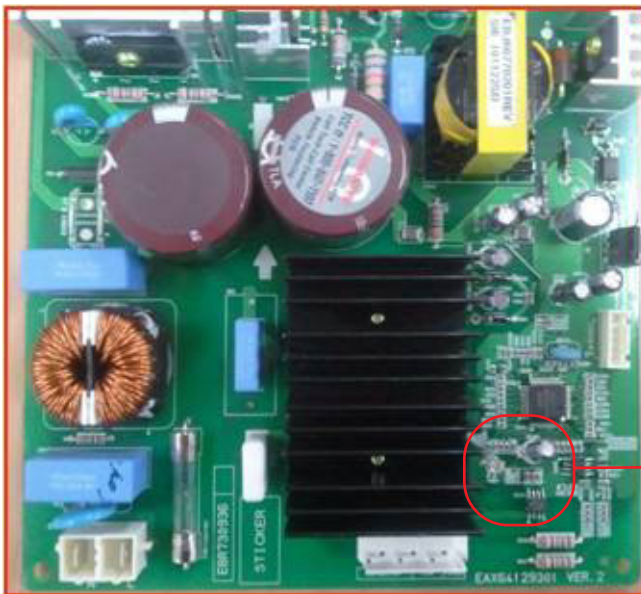

Step 2) Check for blinking frequency of LED and PCB



When compressor is normal, it does not blink
: Refer to the next page to find out what actions to take according to how many times LED blink

No	LED operating condition	Cause	Service guideline
1	<p>LED two - time repetiton (Stroke Trip)</p>  <p>..on - on - off - on - on - off - on - on - off ..repeating</p>	PCB Parts defect or Compress or Connector miss connecting (Piston over run)	<ol style="list-style-type: none"> 1. Please check, Whether connector of compressor is attached rightly or not. after power off 2. After the first action, You check on normal operation of compressor. 3. If the same symptom arises after the second action, replace PCB
2	<p>LED five - time repetiton (Piston Lock Trip)</p>  <p>..on - on - on - on - on - off - on - on - on - on - on - off .. repeating</p>	Piston constraint	<ol style="list-style-type: none"> 1. After resetting power, check if it is running normal 2. If the same symptom arises after the first action 3. If the same symptom arises after the second action, replace compressor
3	<p>LED six - time repetiton (Current Trip)</p>  <p>..on - on - on - on - on - on - off - on - on - on - on - on - off ..repeating</p>	Circuit over current error Or cycle error	<ol style="list-style-type: none"> 1. After resetting power, check if it is running normal 2. If the same symptom arises after the first action 3. If the same symptom arises after the second action, replace compressor
4	<p>LED seven- time repetiton (IPM Fault Trip)</p>  <p>..on - on - on - on - on - on - on - off - on - on - on - on - on - on - off ..repeating</p>	PCB parts defect (IPM)	<ol style="list-style-type: none"> 1. After resetting power, check if it is running normal 2. If the same symptom arises after the first action, replace PCB

12-5 SERVICE DIAGNOSIS CHART

COMPLAINT	POINTS TO BE CHECKED	REMEDY
No Cooling.	<ul style="list-style-type: none"> Is the power cord unplugged from the outlet? Check if the power switch is set to OFF. Check if the fuse of the power switch is shorted. Measure the voltage of the power outlet. 	<ul style="list-style-type: none"> Plug into the outlet. Set the switch to ON. Replace the fuse. If the voltage is low, correct the wiring.
Cools poorly.	<ul style="list-style-type: none"> Check if the unit is placed too close to the wall. Check if the unit is placed too close to the stove, gas cooker, or in direct sunlight. Is the ambient temperature too high or the room door closed? Check if food put in the refrigerator is hot. Did you open the door of the unit too often or check if the door is sealed properly? Check if the Control is set to Warm position. 	<ul style="list-style-type: none"> Place the unit about 4 inches (10 cm) from the wall. Place the unit away from these heat sources. Lower the ambient temperature. Put in foods after they have cooled down. Don't open the door too often and close it firmly. Set the control to Recommended position.
Food in the Refrigerator is frozen.	<ul style="list-style-type: none"> Is food placed in the cooling air outlet? Check if the control is set to colder position. Is the ambient temperature below 41°F(5°C)? 	<ul style="list-style-type: none"> Place foods in the high-temperature section. (front part) Set the control to Recommended position. Set the control to Warm position.
Condensation or ice forms inside the unit.	<ul style="list-style-type: none"> Is liquid food sealed? Check if food put in the refrigerator is hot. Did you open the door of the unit too often or check if the door is sealed properly? 	<ul style="list-style-type: none"> Seal liquid foods with wrap. Put in foods after they have cooled down. Don't open the door too often and close it firmly.
Condensation forms in the Exterior Case.	<ul style="list-style-type: none"> Check if the ambient temperature and humidity of the surrounding air are high. Is there a gap in the door gasket? 	<ul style="list-style-type: none"> Wipe moisture with a dry cloth. It will disappear in low temperature and humidity. Fill up the gap.
There is abnormal noise.	<ul style="list-style-type: none"> Is the unit positioned in a firm and even place? Are any unnecessary objects placed in the back side of the unit? Check if the Drip Tray is not firmly fixed. Check if the cover of the compressor enclosure in the lower front side is taken out. 	<ul style="list-style-type: none"> Adjust the Leveling Screw, and position the refrigerator in a firm place. Remove the objects. Fix the Drip Tray firmly in the original position. Place the cover in its original position.
Door does not close well.	<ul style="list-style-type: none"> Check if the door gasket is dirty with an item like juice. Is the refrigerator level? Is there too much food in the refrigerator? 	<ul style="list-style-type: none"> Clean the door gasket. Position in a firm place and level the Leveling Screw. Make sure food stored in shelves does not prevent the door from closing.
Ice and foods smell unpleasant.	<ul style="list-style-type: none"> Check if the inside of the unit is dirty. Are foods with a strong odor unwrapped? The unit smells of plastic. 	<ul style="list-style-type: none"> Clean the inside of the unit. Wrap foods that have a strong odor. New products smell of plastic, but this will go away after 1-2 weeks.

● Other possible problems:

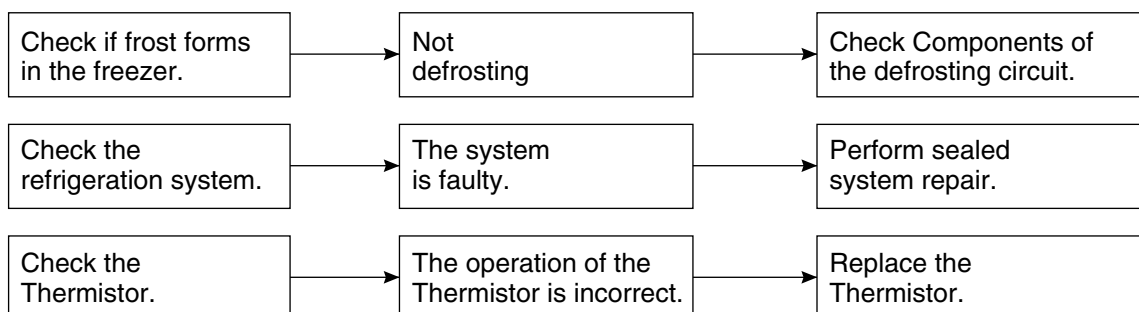

12-6 REFRIGERATION CYCLE

▼ Troubleshooting Chart

CAUSE		STATE OF THE UNIT	STATE OF THE EVAPORATOR	TEMPERATURE OF THE COMPRESSOR	REMARKS
LEAKAGE	PARTIAL LEAKAGE	Freezer compartment and Refrigerator don't cool normally.	Low flowing sound of Refrigerant is heard and frost forms in inlet only.	A little higher than ambient temperature.	<ul style="list-style-type: none"> Refrigerant level is low due to a leak. Normal cooling is possible by restoring the normal amount of refrigerant and repairing the leak.
	COMPLETE LEAKAGE	Freezer compartment and Refrigerator don't cool normally.	Flowing sound of refrigerant is not heard and frost isn't formed.	Equal to ambient temperature.	<ul style="list-style-type: none"> No discharging of Refrigerant. Normal cooling is possible by restoring the normal amount of refrigerant and repairing the leak.
CLOGGED BY DUST	PARTIAL CLOG	Freezer compartment and Refrigerator don't cool normally.	Flowing sound of refrigerant is heard and frost forms in inlet only.	A little higher than ambient temperature.	<ul style="list-style-type: none"> Normal discharging of the refrigerant. The capillary tube is faulty.
	WHOLE CLOG	Freezer compartment and Refrigerator don't cool.	Flowing sound of refrigerant is not heard and frost isn't formed.	Equal to ambient temperature.	<ul style="list-style-type: none"> Normal discharging of the Refrigerant.
MOISTURE CLOG		Cooling operation stops periodically.	Flowing sound of refrigerant is not heard and frost melts.	Lower than ambient temperature.	<ul style="list-style-type: none"> Cooling operation restarts when heating the inlet of the capillary tube.
DEFECTIVE COMPRESSION	COMP-RESSION	Freezer and Refrigerator don't cool.	Low flowing sound of refrigerant is heard and frost forms in inlet only.	A little higher than ambient temperature.	<ul style="list-style-type: none"> Low pressure at high side of compressor due to low refrigerant level.
	NO COMP-RESSION	No compressing operation.	Flowing sound of refrigerant is not heard and there is no frost.	Equal to ambient temperature.	<ul style="list-style-type: none"> No pressure in the high pressure part of the compressor.

12-6-1 Cleaning

There is no need for routine condenser cleaning in normal Home operating environments. If the environment is particularly greasy or dusty, or there is significant pet traffic in the home, the condenser should be cleaned every 2 to 3 months to ensure maximum efficiency.

If you need to clean the condenser:

- Remove the mechanical cover.
- Use a vacuum cleaner with a soft brush to clean the grille, the open areas behind the grille and the front surface area of the condenser.
- Replace the mechanical cover.

12-6-2 SEALED SYSTEM DIAGNOSIS

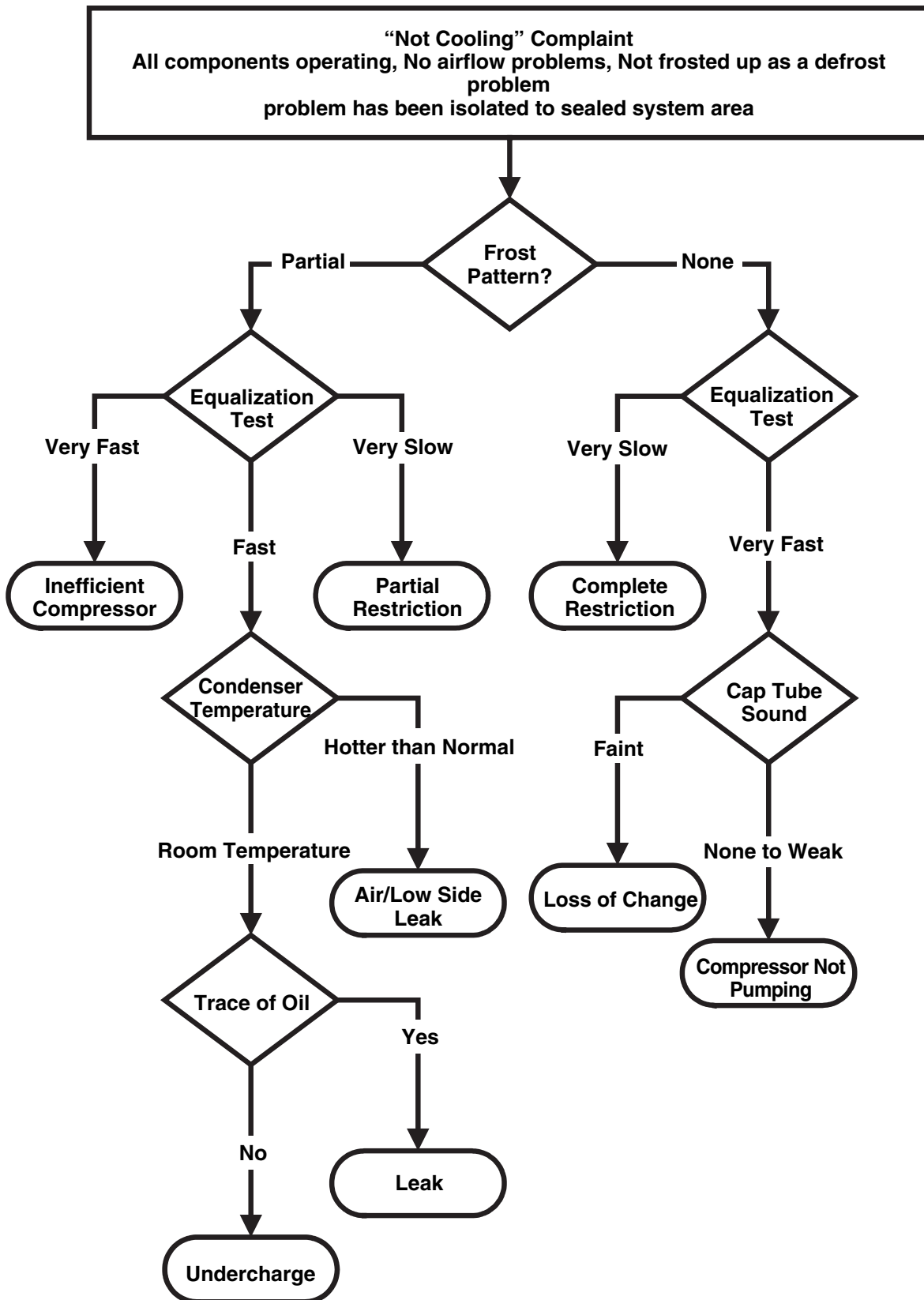

(The equalization test is trying to restart a compressor using a start kit after it has been operating.)

13. ICEMAKER OPERATING METHOD AND TROUBLE SHOOTING

13-1 Icemaker's Basic Operating Method

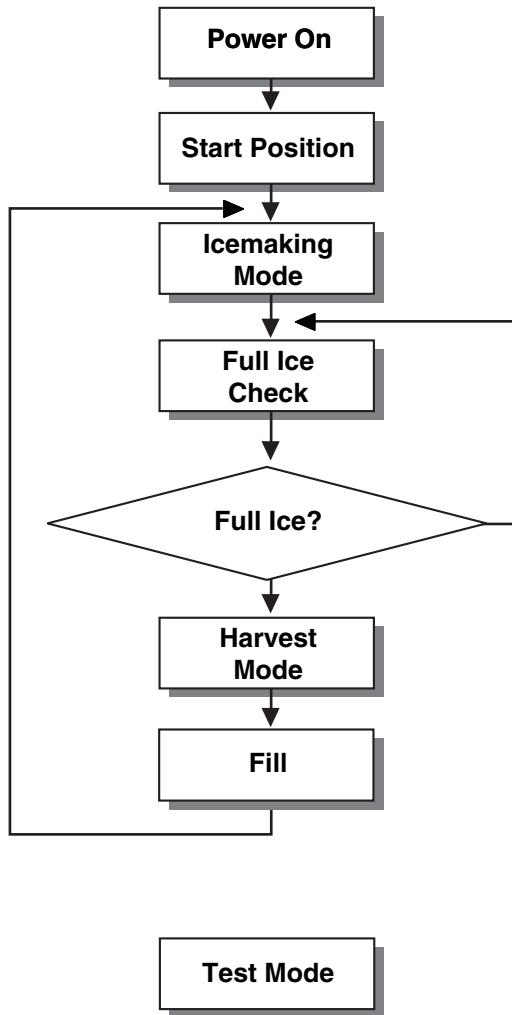

• Adjusts Ice Tray to Start Position with power on.



• Waits until water becomes ice.
 ※ For cold air circulation, Ice tray will be on a slightly tilt one hour after ice-making mode begins. A tilt ice tray means icemaker's normal operation.



• If water becomes ices in the ice tray, Ice-detecting sensor check if the ice bin is full.



• Twist the ice tray to drop ice into the ICE BIN.



• Supply water to the ice tray by operating the solenoid valve.



• To force water to supply to the ice tray, or check icemaker's condition press and hold the **FILL Key** for about 3seconds.
 In the test mode, The icemaker will run through 3 stages step by step
 : **Harvest** → **Fill water** → **Ice making**

To reset the icemaker's operation, set the power switch OFF position and back it to ON position.

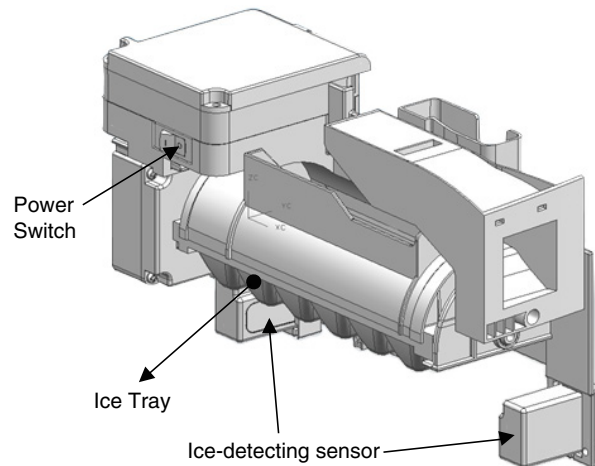

Icemaker Unit

13-2 ICE MAKER FUNCTIONS

13-2-1 Icemaking Mode

1. Icemaking Mode begins right after the ice tray fills with water.
 2. Icemaker waits until water becomes ice in the ice tray.
- ※ Ice-detecting sensor checks if the ice bin is full every 2min.

13-2-2 Harvest Mode

At least in 110min, since icemaker begun icemaking mode, Icemaker starts to twist the ice tray to drop ices into the Ice bin. (After installation, at least 1day is needed to make ices)

- ※ If the icemaker never drop ices to the ice bin though water becomes ices in the ice tray, check the real temperature of compartment. (not temperature on display)
Icemaker needs below 0°F to drop ices to ice bin.

13-2-3 Fill/Park Position

Once the normal harvest mode has been completed, the water solenoid will be activated.

13-3 Trouble Shooting Ice & Water system Issues

13-3-1 Icemaker not making ice or not making enough ice (Environmental Diagnosis)

- Icemaker can't make ices itself. Basically, water, temperature and time are needed.
- Water : If no Water, then no Ice.
 - Temperature : The compartment, where the icemaker is located, has to be at least 1°F so that icemaker dumps ices to the bin.
 - Time : At least 80 minutes must be passed to make one series of ices after water comes into icemaker.
- ※ **Test Mode should not be carried out before checking below.**

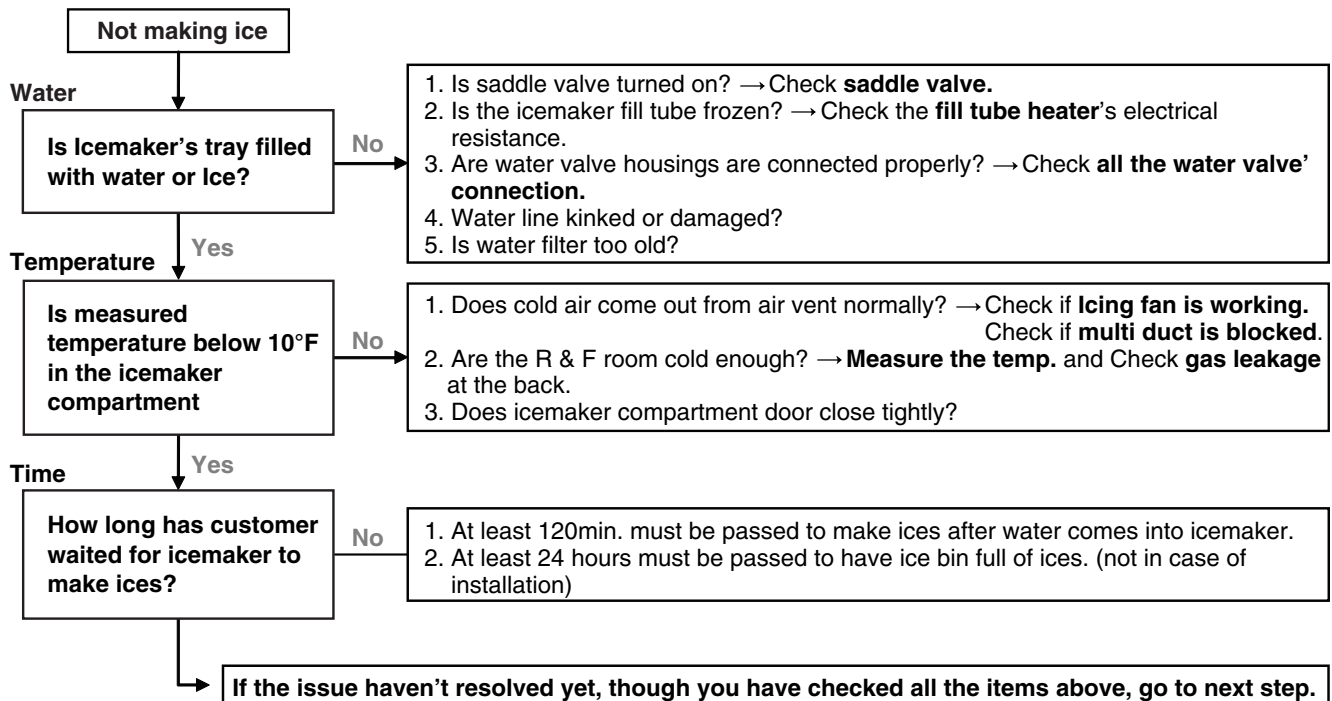

13-3-2 Icemaker not making ice or not making enough ice (Icemaker Unit & Ice-detecting sensor Diagnosis)

► Icemaker Unit and Ice-detecting sensor Diagnosis

The icemaker unit and Ice-detecting sensor is programmed to be diagnosed.

Follow the procedure step by step to check to see if icemaker and Ice-detecting sensor is working normally.

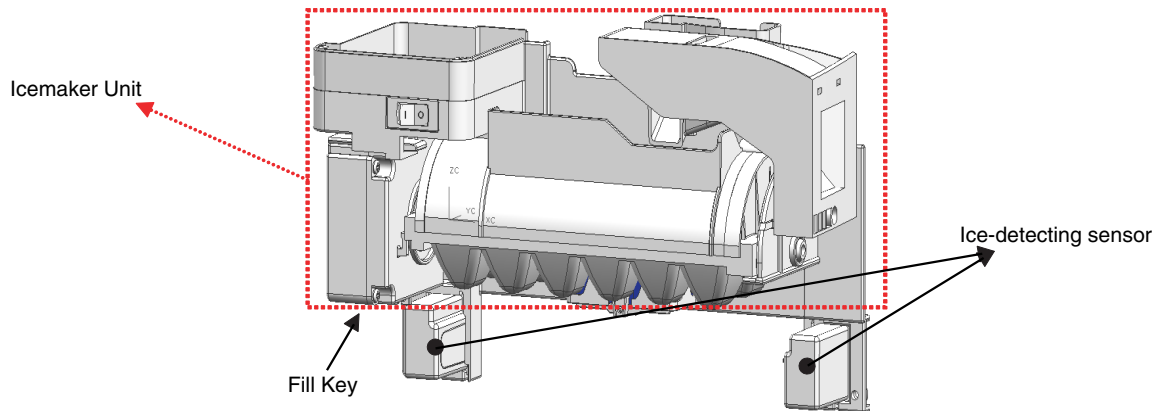

1st STEP (Icemaker Unit Diagnosis)

Press the fill key for about 3sec. If the icemaker runs 2 stages of harvest and filling water step by step, It means icemaker's mechanism is normal.



※ Caution : Be sure that the ice tray is not filled with water before pressing fill key.

2st STEP (Ice-detecting sensor Diagnosis)

1. Remove Ice bin from compartment

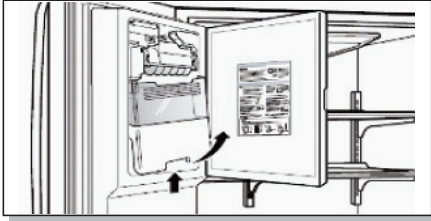

2. Close the left door (Door switch pushed)

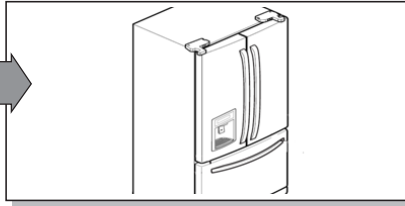

3. Wait for 3min.



4. Freezer door stays open

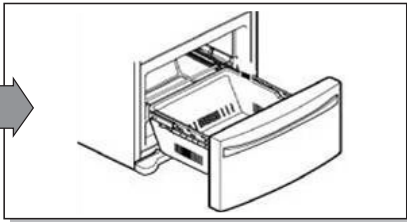

5. Push the refrigerator button & lock button at the same time.



If **"ETY"** is shown on the display after the procedure above, Ice-detecting sensor is **normal**.
If **"FULL"** is shown on the display after the procedure above, Ice-detecting sensor is **abnormal**.
※ ETY = empty

13-3-3 Icemaker not making ice or not making enough ice (Other Suspected Items)

Strongly suspect items below If the issue remains yet, though all the diagnosis for icemaker has been carried out.

- Cap duct bad sealing
- Defective thermal sensor in the icemaker compartment
- Not cold icemaker compartment area (sealed system)

13-3-4 Not Dispensing Ice

► Clogged Ice In the Ice Bin (suspected items)

- Customer haven't used ice dispenser over a week.
→ **Resolution** : the ices gets stuck if customer doesn't use ice dispenser.
In this case, empty the ice bin and wait until the new ices are stacked in the ice bin.
- Temperature of icemaker compartment is not cold enough.
→ **Resolution** : Check ice fan, sealed system, cap duct, vent and other items related to temperature.
- Cap duct doesn't seal the air properly.
→ **Resolution** : Possibly, warm air could get into the compartment and make ices get stuck. Replace the cap duct with new one.
- In-door geared motor doesn't work
→ **Resolution** : Change the in-door geared motor and test it.
- The water comes out of fill cup and the water get into the ice bin.
→ **Resolution** : The water pressure from shutoff valve is too high.
Recommend to use regulator to the customer and close the shutoff valve slightly.

► Clogged Ices In the Chute (suspected items)

- Cap duct doesn't seal the air properly.
→ **Resolution** : Possibly, warm air could get into the compartment and make ices get stuck. Replace the cap duct with new one.

14. DESCRIPTION OF FUNCTION & CIRCUIT OF MICOM

14-1 FUNCTION

14-1-1 Function

1. When the appliance is plugged in, it is set to 37°F for Refrigerator and 0°F for freezer.
You can adjust the Refrigerator and the Freezer control temperature by pressing the ADJUST button.
2. When the power is initially applied or restored after a power failure, it is set to Control temperature Previously.
3. If you do not press any button after turning on the power, only CRUSH or CUBE Label that has been selected will be turned on and all other LEDs on the display Panel will be turned off within 60 seconds. (Power Save Mode)
4. If you press a button, only CRUSH, CUBE label and Lock icon that has been selected will be turned on and all other LEDs on the display Panel will be turned off within 20 seconds. (Power Save Mode)

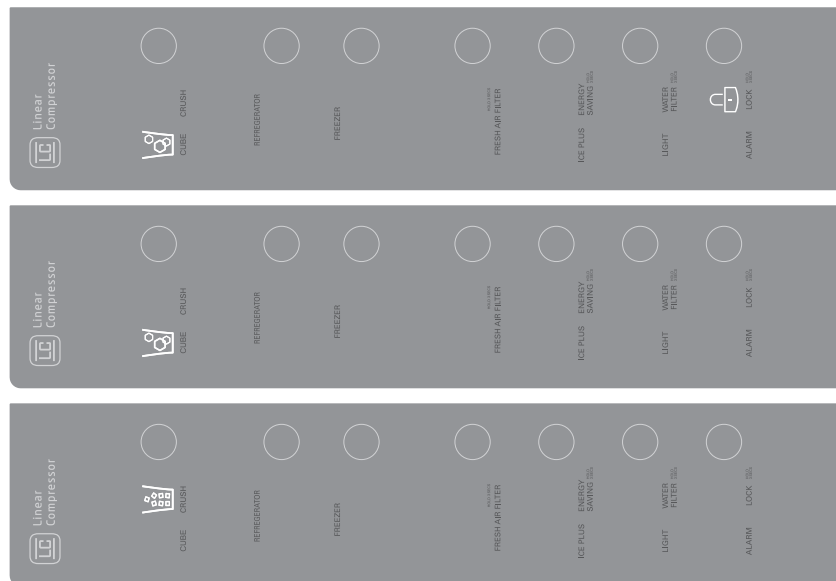

14-1-2 How to Toggle the Display between °F & °C

1. The initial setting is °F and the display temperature mode can be changed from °F to °C or °C to °F by pressing and holding the FRZ TEMP and the REF TEMP keys at the same time for over 5 seconds.

14-1-3 Lock function (dispenser and display button lock)

1. When the refrigerator is first turned on, the buttons are not locked. "LOCK" is deactivated with no light on.
2. To lock the display, the dispenser, and the control panel, press and hold the LOCK button for 3 seconds. "LOCK" is activated with "Lock Icon" on.
3. The LOCK button is the only control feature that remains active in the locked state. The buzzer sound, other control buttons, and the dispenser are deactivated.
4. To release from the locked state, press and hold the LOCK button again for 3 seconds.
5. If you don't hold the Alarm/Lock button more than 3 seconds, Alarm function will be changed and alarm for opened door will be on/off same as alarm icon indicating.

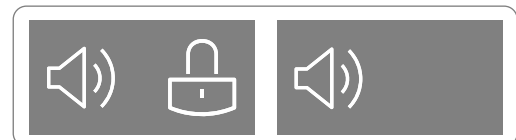



Ex) In selecting "LOCK"

Ex) In selecting "LOCK" again

14-1-4 Filter condition display function

1. There is a replacement indicator light for the filter cartridge on the dispenser.
2. Water filter needs replacement once six months or of using water filter.
3. When the Water Filter Icon blinks, you must exchange the filter.
4. After replacing the filter, press and hold the Light/Filter button for more than 3 seconds. After then water Filter icon turn off with reset status.

Classification	In initial Power On / Filter RESET	Blinking
Filter Status Display		

14-1-5 Air Filter selection

Please select this function for Air Filter.

- When you press the Air Filter Button, the "POWER" will be turned on again.
- Air Filter POWER function automatically turns off after a fixed time passes.

14-1-6 Ice Plus selection

1. Please select ice plus function for quick freezing.
2. When you press the ice plus button, the ice plus icon will be turned on again.
3. Ice plus function automatically turns off after a fixed time passes.
4. If you want additional power save, you can turn on energy saving (some heater off for anti-dew).
5. To turn on or off the energy saving function, press Ice plus/Energy saving Button for more than 3 seconds.
6. We recommend using energy saving function when you go out for quite a long time and are out of the rainy season.



14-1-7 Dispenser use selection

You can select water or ice by separated pad switch.

- When you press ice type button, ice type will be changed. (Crush or Cube)
- Hold your cup in the dispenser for a few seconds after dispensing ice or water to allow the last pieces of ice drops of water to fall into the cup.
- When after initially establishing the water comes out, the water tank inside fills and until at the time of quality the hour is caught.



14-1-8 CONTROL OF FREEZER FAN MOTOR

1. Freezer fan motor has high and standard speeds.
2. High speed is used at power-up, for Ultra Ice, and when refrigerator is overloaded.
Standard speeds is used for general purposes.
3. To improve cooling speed, the RPM of the freezer fan motor change from normal speed to high.
4. High speed (2700RPM) : Initial power on or load corresponding operation, Ultra Ice.
Normal speed (2400RPM) : General working conditions.

14-1-9 Cooling Fan Motor

1. The cooling fan is switched ON and OFF in conjunction with the compressor.
2. The cooling fan Motor has high and standard speeds. (When room temperature more high then 38°C speed is high)
3. The Failure sensing method is the same as in the fan motor of the freezing fan motor(refer to failure diagnosis function table for failure display).

14-1-10 Ice Compartment Fan

1. The Icing Fan is controlled by the the sensor on the top of the ice compartment.
2. The Failure sensing method is the same as in the fan motor of the freezer
(refer to failure diagnosis function table for failure display)

14-1-11 Refrigeration room Fan Motor

1. The refrigeration room fan is switched ON and OFF in conjunction with the refrigeration room temperature.
2. The Failure sensing method is the same as in the fan motor of the freezing fan motor (refer to failure diagnosis function table for failure display).

14-1-12 Ice PLUS

1. The purpose of this function is to intensify the cooling speed of freezer and to increase the amount of ice.
2. Whenever selection switch is pressed, selection/release, the Icon will turn ON or OFF.
3. If there is a power outage and the refrigerator is powered on again, Ice PLUS will be canceled.
4. To activate this function, press the Ice PLUS key and the Icon will turn ON. This function will remain activated for 24 hrs. The first one hour the compressor, Freezer Fan and Icing Fan will be ON. The next 23 hours the Ice room will be controlled at the lowest temperature. After 24 hours or if the Ice PLUS key is pressed again, the Ice room will return to its previous temperature.
5. During the first hour :
 - (1) Compressor, Freezer Fan and Icing Fan run continuously.
 - (2) If a defrost cycle begins during the first 30 minutes of Ice Plus, the Ice PLUS cycle will complete its cycle after defrosting has ended.
If the defrost cycle begins when Ice Plus has run for more than 30 minutes, Ice PLUS will run for 40 minutes after the defrost is completed.
 - (3) If Ice PLUS is pressed during defrost, Ice Plus Icon is on but this function will start seven minutes after defrost is completed and it shall operate for three hours.
 - (4) If Ice Plus is selected within seven minutes after compressor has stopped, the compressor (compressor delays seven minutes) shall start after the balance of the delay time.
6. For the rest of the 23 hours, the Ice room will be controlled at the lowest temperature.

14-1-13 How to set the display mode and cancel it

1. With the refrigerator door open, keep pressing the Refrigerator Temp Button and ICE PLUS Button more than 5 seconds, then it goes to the display mode with Special Beep Sound With Special Beep Sound.
2. Perform the same way again to cancel the display mode.
3. All Freezing unit will be turned off at display mode (Exceptions : Lamp, Display)

14-1-14 Defrosting (removing frost)

1. Defrosting starts each time the COMPRESSOR running time Between 7~50 hours.
2. For initial power on or for restoring power, defrosting starts when the compressor running time reaches 4 hours.
3. Defrosting stops if the sensor temperature reaches 46.4°F(8°C) or more. If the sensor doesn't reach 46.4°F(8°C) in 1 hours, the defrost mode is malfunctioning. (Refer to the defect diagnosis function, 8-1-15.)
4. Defrosting won't function if its sensor is defective (wires are cut or short circuited)

14-1-15 Defect Diagnosis Function

1. Automatic diagnosis makes servicing the refrigerator easy.
2. When a defect occurs, the buttons will not operate; but the tones. such as ding. will sound.
3. When the defect CODE removes the sign, it returns to normal operation (RESET).
4. The defect CODE shows on the Refrigerator and Freezer Display.



- * Display check function: If simultaneously pressing Ultra Ice button and freezing temperature adjustment button for a second, display LCD graphics on. If releasing the button, the LCD graphic displays the previous status.
You can check the error code Within 3-hour Period from initial error

14-1-16 Auto pantry

1. The temperature control will automatically start upon the selected Auto Pantry temperature control.
2. You can adjust the Pantry control with three different temperature ranges by pressing the Temp.Selector button.

15. EXPLODED VIEW & REPLACEMENT PARTS LIST

CASE PARTS

CAUTION : Use the part number to order part, not the position number.

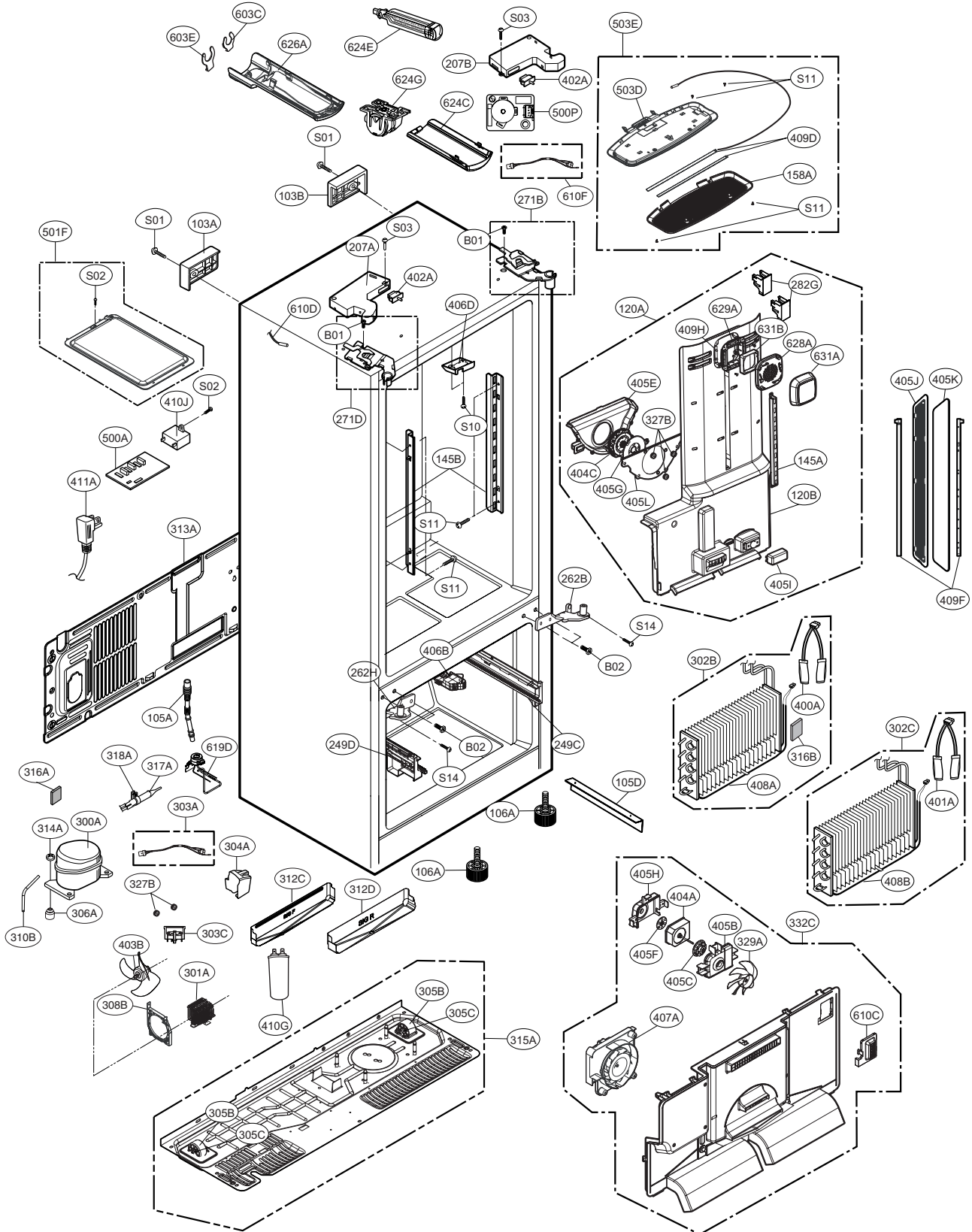

FREEZER PARTS

CAUTION: Use the part number to order part, not the position number.

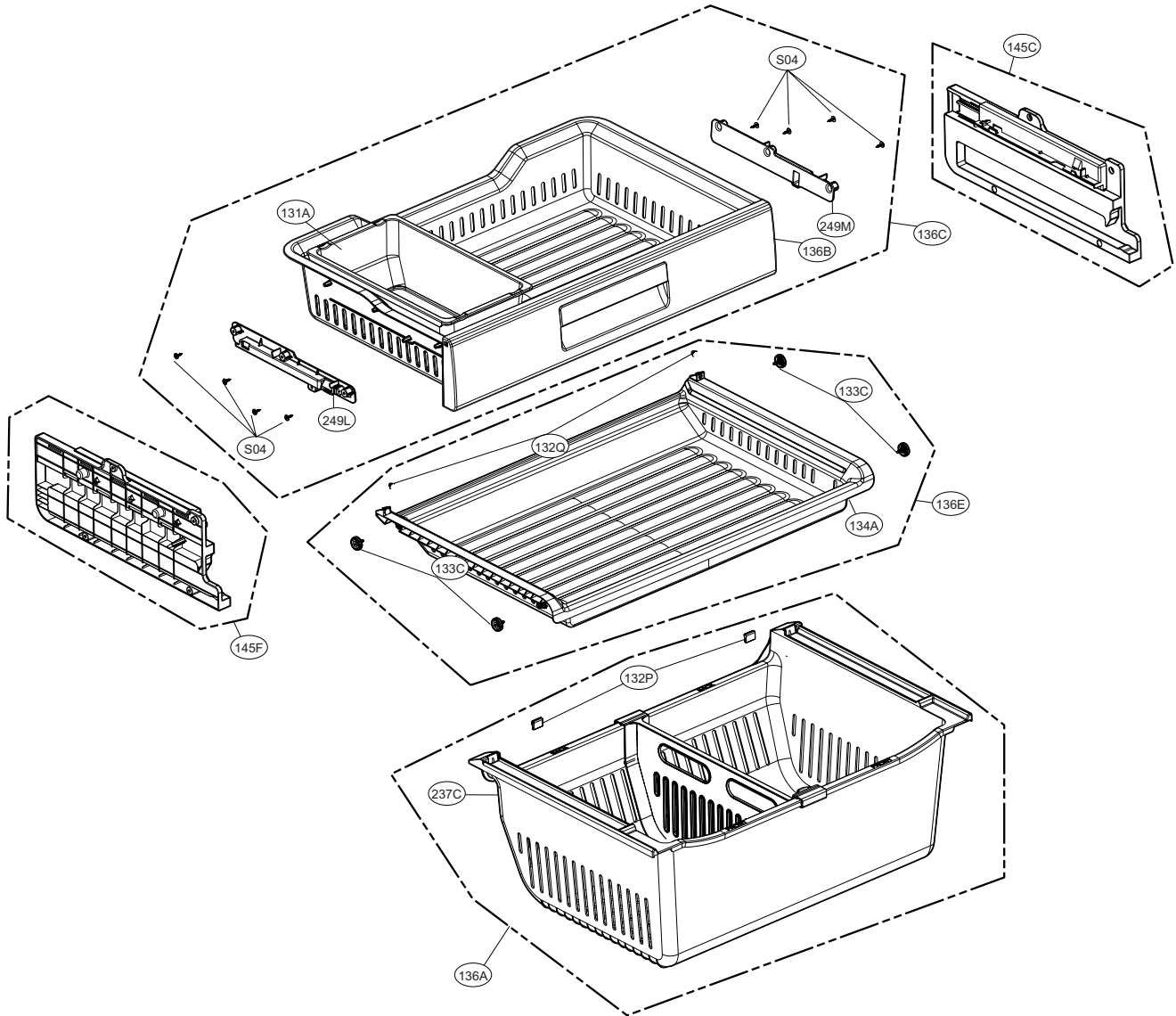

REFRIGERATOR PARTS

CAUTION: Use the part number to order part, not the position number.

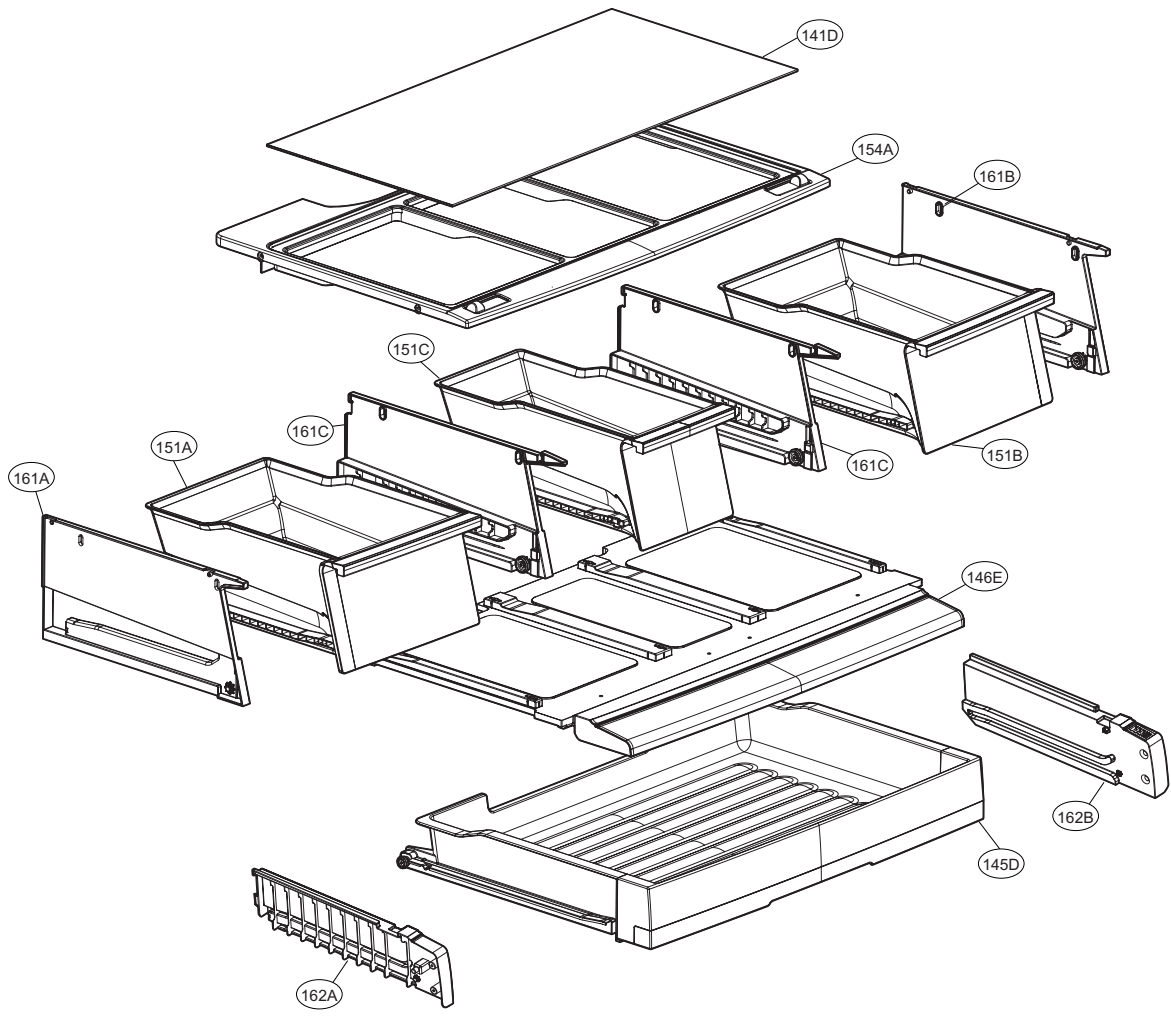
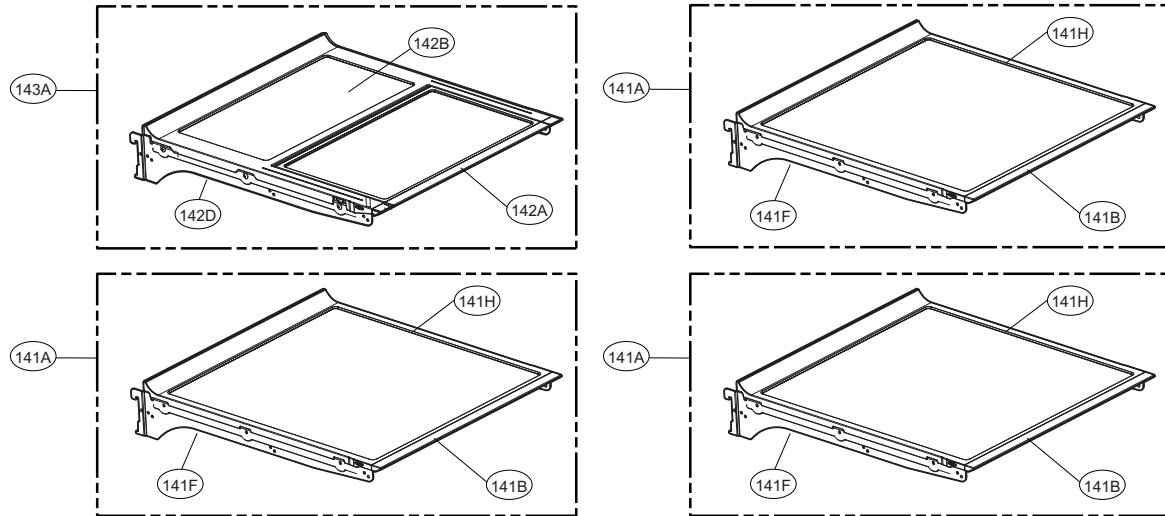

DOOR PARTS

CAUTION: Use the part number to order part, not the position number.

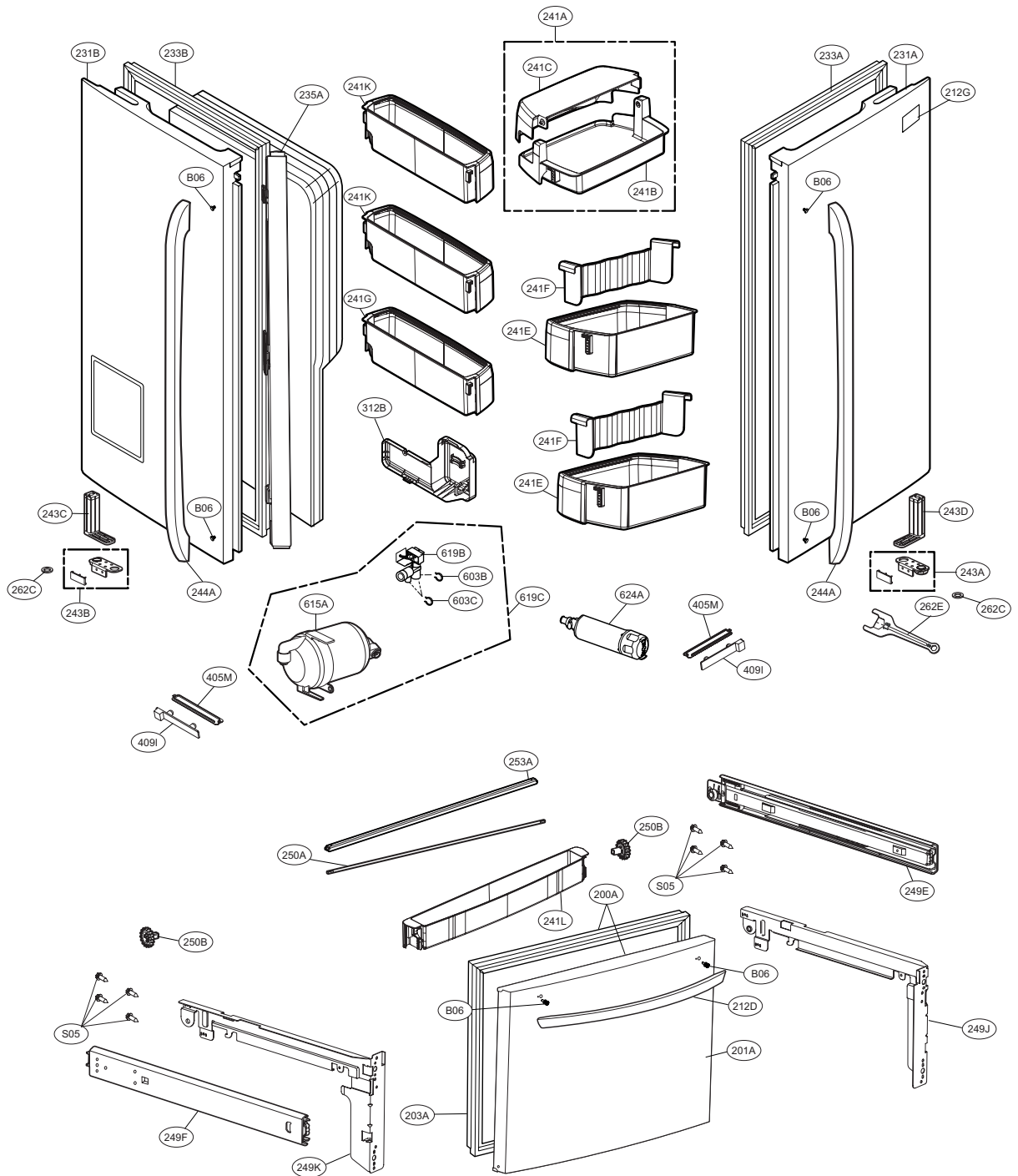

DISPENSER PARTS

CAUTION: Use the part number to order part, not the position number.

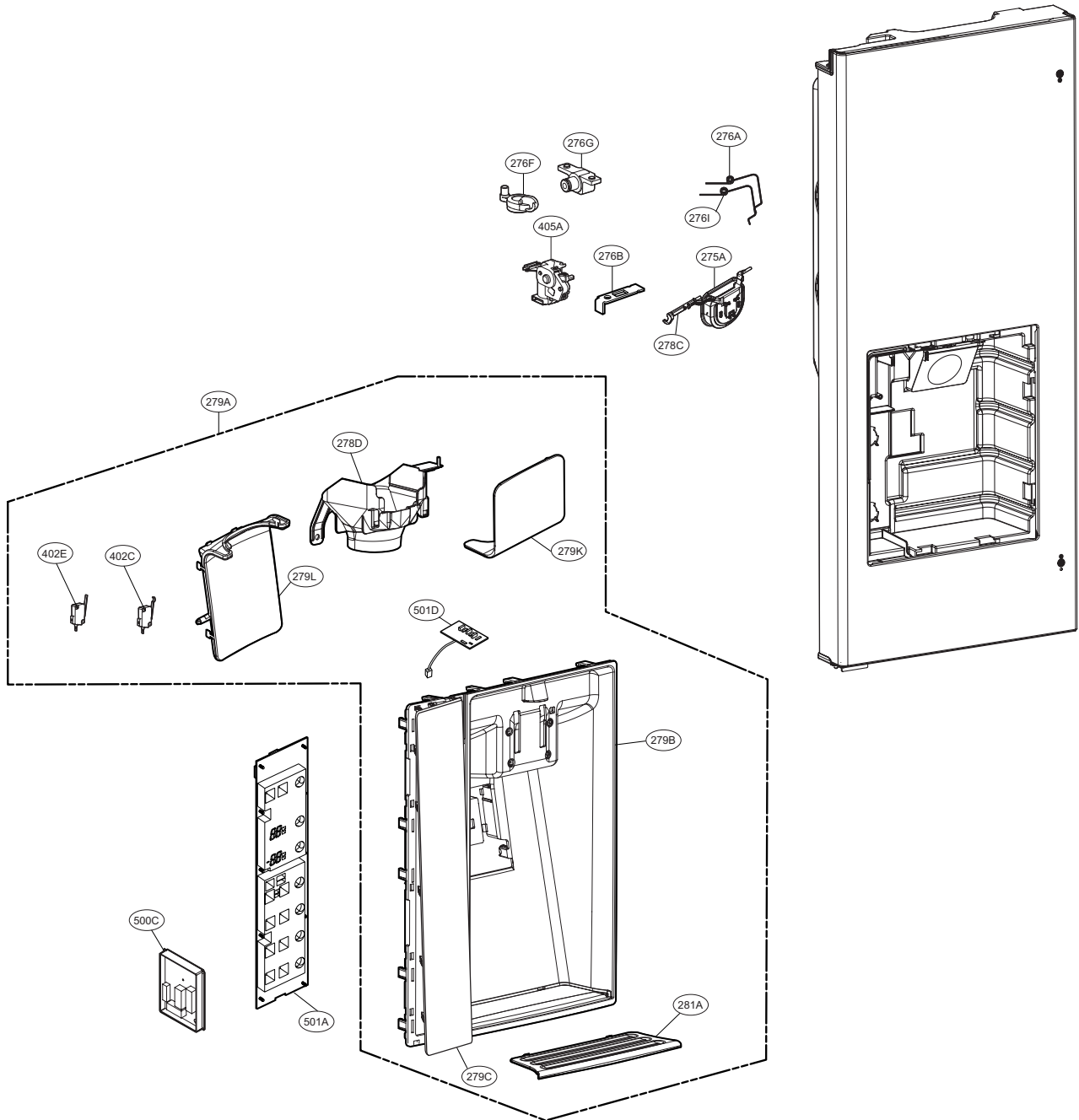

VALVE & WATER TUBE PARTS

CAUTION: Use the part number to order part, not the position number.

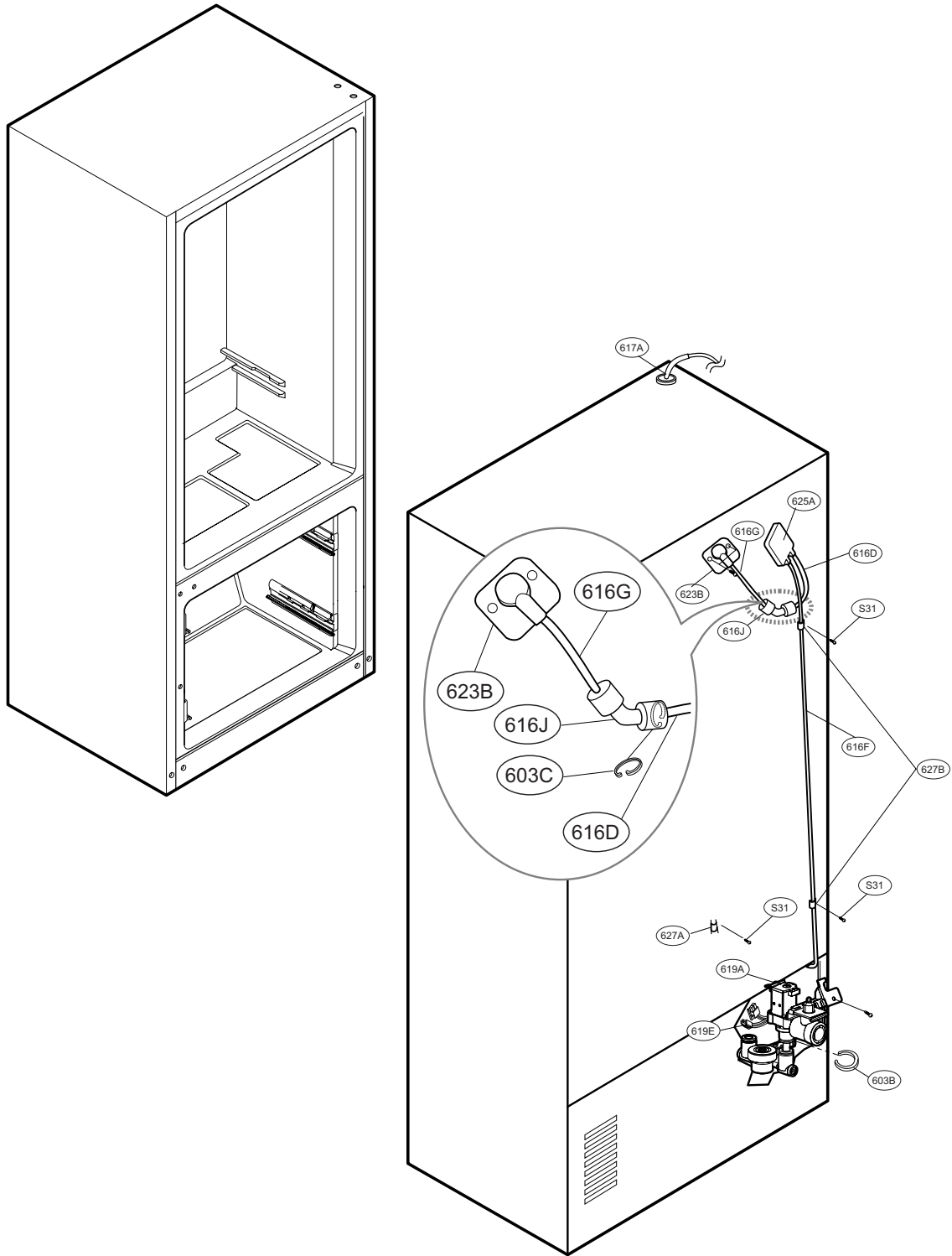

ICE MAKER & ICE BIN PARTS

CAUTION: Use the part number to order part, not the position number.

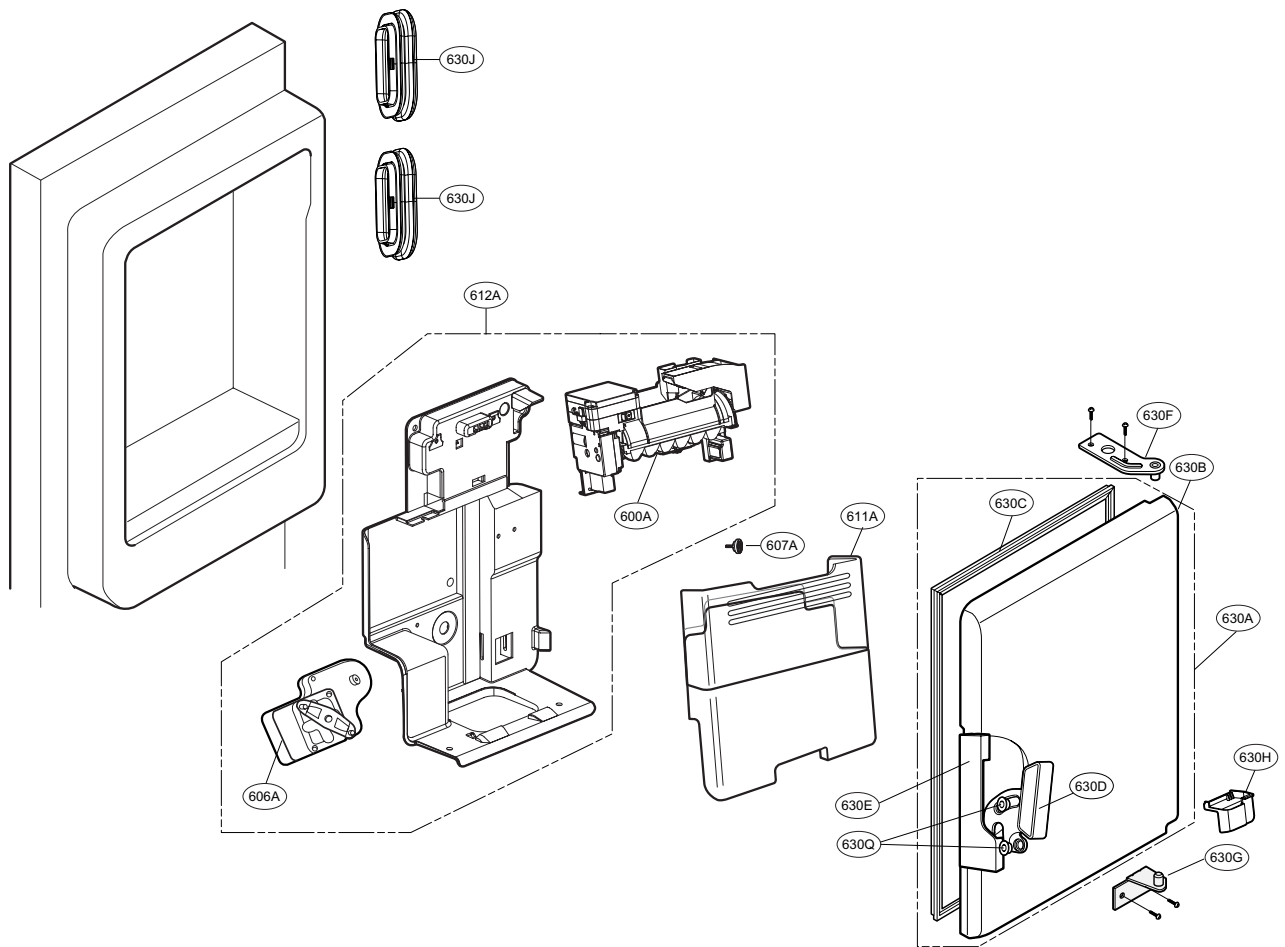



P/No. MFL62188047

MAR., 2011 Printed in Korea