



GE Consumer & Industrial

TECHNICAL SERVICE GUIDE

**Arctica Side-by-Side
Dual Evaporator Refrigerators with
Electronic Touch Controls**



**MODEL SERIES:
PSH23PGR
PSH23PSR**





IMPORTANT SAFETY NOTICE

The information in this service guide is intended for use by individuals possessing adequate backgrounds of electrical, electronic, and mechanical experience. Any attempt to repair a major appliance may result in personal injury and property damage. The manufacturer or seller cannot be responsible for the interpretation of this information, nor can it assume any liability in connection with its use.

WARNING

To avoid personal injury, disconnect power before servicing this product. If electrical power is required for diagnosis or test purposes, disconnect the power immediately after performing the necessary checks.

RECONNECT ALL GROUNDING DEVICES

If grounding wires, screws, straps, clips, nuts, or washers used to complete a path to ground are removed for service, they must be returned to their original position and properly fastened.

GE Consumer & Industrial

Technical Service Guide

Copyright © 2004

All rights reserved. This service guide may not be reproduced in whole or in part in any form without written permission from the General Electric Company.

Table of Contents

3-Way Valve	27
Accumulator	40
Check Valve	40
Components.....	18
Components Locator Views	11
Condenser Fan	21
Control Board Connector Locator	12
Control Features	7
Defrost Cycles.....	22
Dispenser Light	10
Dispenser Lock	10
Dispensing Functions.....	10
Evacuation and Charging Procedure	17
Freezer Evaporator	31
Freezer Evaporator Fan.....	20
Freezer Section Cooling	15
Fresh Food and Freezer Section Cooling	16
Fresh Food Evaporator	37
Fresh Food Evaporator Fan.....	19
Fresh Food Section Cooling	14
Illustrated Parts	44
Introduction	4
Inverter.....	24
Inverter Compressor	26
Liner Protection Mode.....	10
Nomenclature.....	6
Refrigeration System	14
Replacing Freezer Evaporator Using the Brazing Method.....	33
Replacing Freezer Evaporator Using the LOKRING Method	35
Replacing Fresh Food Evaporator Using the Brazing Method.....	38
Replacing Fresh Food Evaporator Using the LOKRING Method	39
Replacing the 3-Way Valve	29
Schematic	43
Technical Data	5
Thermistors	18
Troubleshooting	41
Warranty.....	62

Introduction

This new Arctica dual evaporator refrigerator has the following features:

- Separate freezer and fresh food evaporators with independent cooling.
- No damper/air inlet assembly in the fresh food section creates more usable space on the top shelf.
- Greater fresh food humidity to keep food fresher, longer.
- 20% less freezer defrost for better food preservation.
- 3-Way valve to direct refrigerant flow.
- Nearly silent, only 30 dBA.

The 3-speed compressor is controlled by an inverter that receives input from the low voltage DC side of the main control board. The inverter always has 120 VAC applied when the refrigerator is connected to power. The main control board still makes compressor decisions based on the input of thermistors, door-open time, and input from the temperature control panel. The main control board also operates the condenser fan, fresh food fan, freezer fan and adaptive defrost.

The most significant difference from previous models is that the freezer and fresh food evaporators are separate. The 3-way valve directs refrigerant flow to each evaporator as needed. The fresh food section no longer relies on the freezer evaporator for cooling. The evaporators are controlled separately by the main control board through the 3-way valve.



Technical Data

DISCONNECT POWER CORD BEFORE SERVICING

IMPORTANT - RECONNECT ALL GROUNDING DEVICES

All parts of this appliance capable of conducting electrical current are grounded. If grounding wires, screws, straps, clips, nuts or washers used to complete a path to ground are removed for service, they must be returned to their original position and properly fastened.

ELECTRICAL SPECIFICATIONS

Temperature Control (Position 5) 7-(-11) °F
 Defrost Control 60hrs @ 45 min
 w/ no door openings
 Overtemperature Thermostat 140-110°F
 Defrost Thermistor 75°F
 Electrical Rating: 115V AC 60 Hz 11.6 Amp
 Maximum Current Leakage 0.75 mA
 Maximum Ground Path Resistance 0.14 Ohms

NO LOAD PERFORMANCE

Control Position MID/MID
 and Ambient of: 70° F 90° F

Fresh Food, °F 34-40 34-40
 Frozen Food, °F (-3) 3 (-3) 3
 Run Time, % <80 80-100

REFRIGERATION SYSTEM

Refrigerant Charge (R134a) 6.5 ounces
 Compressor 833 BTU/hr @
 3000 RPM
 Minimum Compressor Capacity 22 inches
 Minimum Equalized Pressure
 @ 70° F 40 PSIG
 @ 90° F 54 PSIG

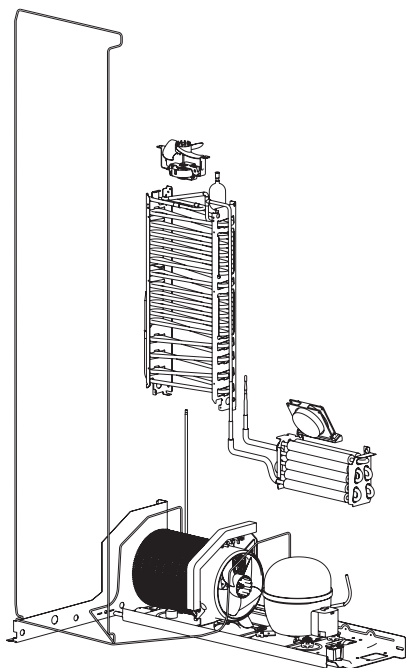

IMPORTANT SAFETY NOTICE

This information is intended for use by individuals possessing adequate backgrounds of electrical, electronic and mechanical experience. Any attempt to repair a major appliance may result in personal injury and property damage. The manufacturer or seller cannot be responsible for the interpretation of this information, nor can it assume any liability in connection with its use.

INSTALLATION

Minimum clearance required for air circulation:
 TOP 1"
 SIDES 0.125"
 REAR 0.5"

AIR FLOW

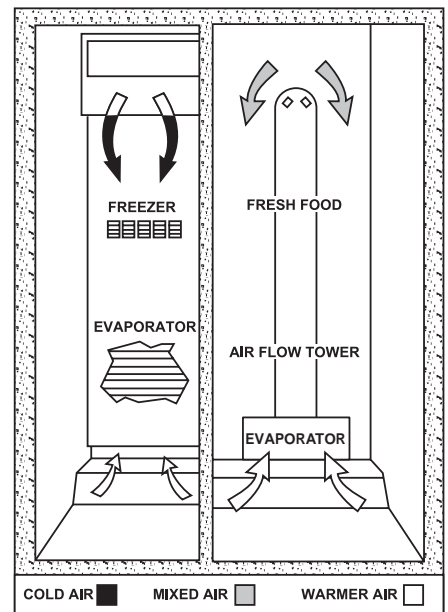
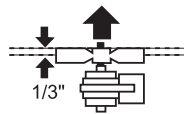

Nomenclature

P S H 23 P G R A F BB

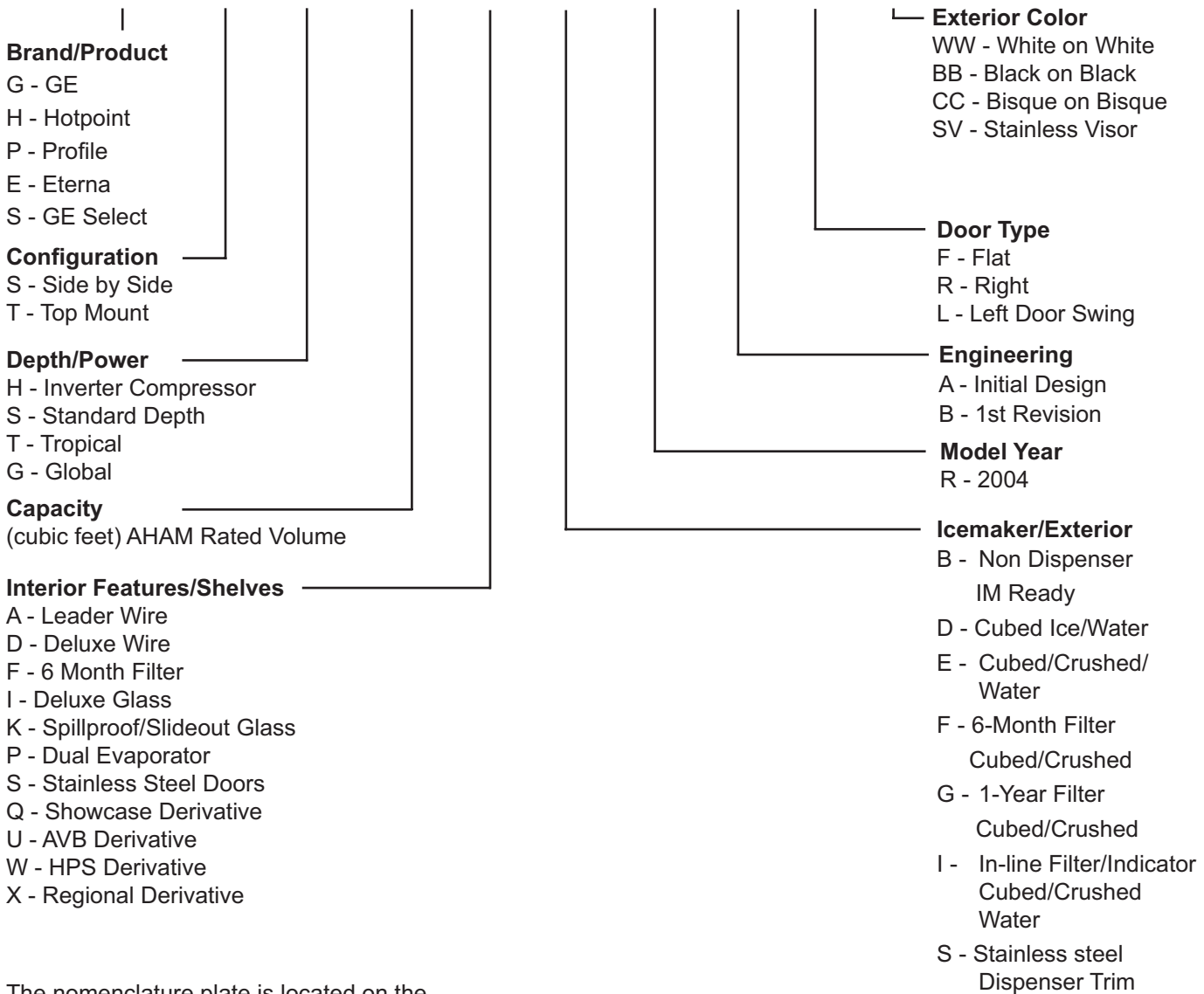

The nomenclature plate is located on the upper right wall of the fresh food compartment. It contains the following information:



- Model and Serial Number
- Minimum Installation Clearances
- Electrical Voltage, Frequency
- Maximum Amperage Rating
- Refrigerant Charge and Type

Serial Number

The first two numbers of the serial number identify the month and year of manufacture.

Example: **AG123456S** = January, 2004

A - JAN	2005 - H	The letter designating the year repeats every 12 years.
D - FEB	2004 - G	
F - MAR	2003 - F	
G - APR	2002 - D	
H - MAY	2001 - A	
L - JUN	2000 - Z	
M - JUL	1999 - V	
R - AUG	1998 - T	
S - SEP	1997 - S	
T - OCT	1996 - R	
V - NOV	1995 - M	
Z - DEC	1994 - L	

Example:
 T - 1974
 T - 1986
 T - 1998

Control Features



- The temperature controls are preset in the factory at 37°F for the refrigerator compartment and 0°F for the freezer compartment.
 - Allow 24 hours for the temperature to stabilize to the preset recommended settings.
 - The temperature controls can display both the SET temperature as well as the actual temperature in the refrigerator and freezer.
 - The actual temperature may vary slightly from the SET temperature based on usage and operating environment.
 - Setting either or both controls to OFF stops cooling in both the freezer and refrigerator compartments, but does not shut off electrical power to the refrigerator.
-
- To change the temperature, press and release the WARMER or COLDER pad. The SET light will come on and the display will show the set temperature.
 - To change the temperature, tap either the WARMER or COLDER pad until the desired temperature is displayed.
 - Refrigerator temperatures can be adjusted between 34°F and 44°F and the freezer temperatures can be adjusted between -6°F and +6°F.
 - Once the desired temperature has been set, the temperature display will return to the actual refrigerator and freezer temperatures after 5 seconds. Several adjustments may be required. Each time you adjust controls, allow 24 hours for the refrigerator to reach the temperature you have set.
 - To turn the cooling system off, tap the WARMER pad for either the refrigerator or the freezer until the display shows OFF. To turn the unit back on, press the COLDER pad for either the refrigerator or freezer. The SET light will illuminate on the side you selected. Then press the COLDER pad again (on the side where the SET light is illuminated) and it will go to the preset points of 0°F for the freezer and 37°F for the refrigerator.
 - Setting either or both controls to OFF stops cooling in both the freezer and refrigerator compartments, but does not shut off electrical power to the refrigerator.

About CustomCool™

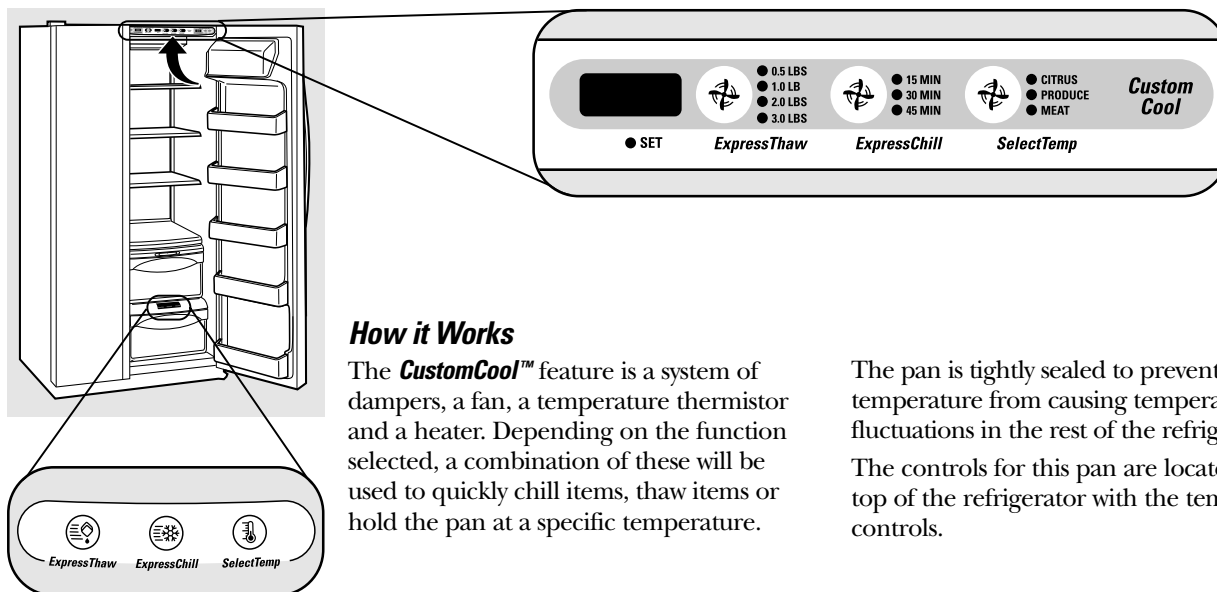

How it Works

The **CustomCool™** feature is a system of dampers, a fan, a temperature thermistor and a heater. Depending on the function selected, a combination of these will be used to quickly chill items, thaw items or hold the pan at a specific temperature.

The pan is tightly sealed to prevent the pan's temperature from causing temperature fluctuations in the rest of the refrigerator.

The controls for this pan are located at the top of the refrigerator with the temperature controls.

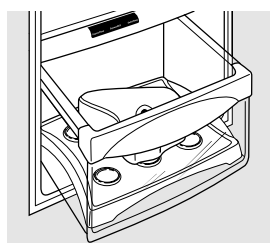

ExpressThaw™

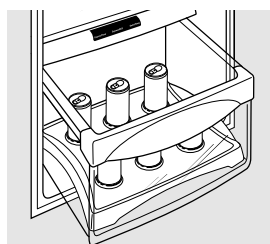

ExpressChill™

How to Use

- 1 Empty the pan. Place the Chill/Thaw tray in the pan. Place the items on the tray and close the pan completely.
- 2 Select the **ExpressThaw™**, **ExpressChill™** or **SelectTemp™** pad. The display and **SET** light will come on. Tap the pad until the light appears next to the desired setting. Use the chart to determine the best setting to use.

- To stop a feature before it is finished, tap that feature's pad until no options are selected and the display is off.
- During **ExpressThaw™** and **ExpressChill™**, the display on the controls will count down the time in the cycle.

- After the **ExpressThaw™** cycle is complete, the pan will reset to the **MEAT** setting (31°F) to help preserve thawed items until they are used.
- The displayed actual temperature of the **CustomCool™** pan may vary slightly from the **SET** temperature based on usage and operating environment.

NOTE: For food safety reasons, it is recommended that foods be wrapped in plastic wrap when using **ExpressThaw™**. This will help contain meat juices and improve thawing performance.

About TurboCool.™

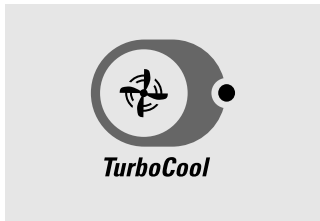

How it Works

TurboCool rapidly cools the refrigerator compartment in order to more quickly cool foods. Use **TurboCool** when adding a large amount of food to the refrigerator compartment, putting away foods after they have been sitting out at room temperature or when putting away warm leftovers. It can also be used if the refrigerator has been without power for an extended period.

Once activated, the compressor will turn on immediately and the fans will cycle on and off at high speed as needed for eight hours. The compressor will continue to run until the refrigerator compartment cools to approximately 34°F (1°C), then it will cycle on and off to maintain this setting. After 8 hours, or if **TurboCool** is pressed again, the refrigerator compartment will return to the original setting.

How to Use

Press **TurboCool**. The refrigerator temperature display will show **TC**.

After **TurboCool** is complete, the refrigerator compartment will return to the original setting.

NOTES: The refrigerator temperature cannot be changed during **TurboCool**.

The freezer temperature is not affected during **TurboCool**.

When opening the refrigerator door during **TurboCool**, the fans will continue to run if they have cycled on.

About the ice and water dispenser. (on some models)



To Use the Dispenser

Select **CUBED ICE** , **CRUSHED ICE**  or **WATER** .

Press the glass gently against the top of the dispenser cradle.

The spill shelf is not self-draining. To reduce water spotting, the shelf and its grille should be cleaned regularly.

If no water is dispensed when the refrigerator is first installed, there may be air in the water line system. Press the dispenser arm for at least two minutes to remove trapped air from the water line and to fill the water system. To flush out impurities in the water line, throw away the first six glassfuls of water.

CAUTION: Never put fingers or any other objects into the ice crusher discharge opening.

Locking the Dispenser

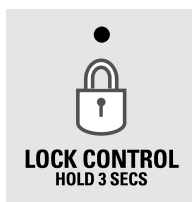

Press the **LOCK CONTROL** pad for 3 seconds to lock the dispenser and control panel. To unlock, press and hold the pad again for 3 seconds.

Dispenser Light



This pad turns the **night light** in the dispenser on and off. The light also comes on when the dispenser cradle is pressed. If this light burns out, it should be replaced with a 6 watt 12V maximum bulb.

Quick Ice



When you need ice in a hurry, press this pad to speed up ice production. This will increase ice production for the following 48 hours or until you press the pad again.

Door Alarm

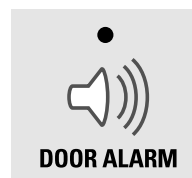

To set the alarm, press this pad until the indicator light comes on. This alarm will sound if either door is open for more than 3 minutes. The light goes out and the beeping stops when you close the door.

Dispenser Light

The LIGHT pad turns the dispenser light on and off. When the light is turned off, it will fade out. The dispenser light will come on automatically when the dispenser cradle is depressed and will fade out 5 seconds after it is released. The LIGHT pad will not turn off the light during dispensing.

Dispensing Functions

The water, crushed ice, and cubed ice functions are controlled by the main control board. To select a function, press the appropriate pad on the dispenser. The LED will light to identify the selection.

To dispense ice cubes or crushed ice, choose the appropriate pad and depress the dispenser cradle. The solenoid and linkage assembly will open the ice chute duct door to dispense the ice. If cubed ice is selected, a solenoid located behind the ice bucket will lift a rod along the side of the bucket. This rod pulls a flapper away from the cutter blades, allowing cubes to bypass the ice crusher. The dispenser duct door will remain open for 3 seconds after dispensing to allow all ice to clear the chute.

The dispenser light will come on automatically when the dispenser cradle is depressed and will fade out 5 seconds after it is released.

Dispenser Lock

When the dispenser system is locked, no dispenser command will be accepted. This includes the dispenser cradle and will prevent accidental dispensing that may be caused by children or pets. If a pad or the cradle is depressed with the system locked, it will be acknowledged with three pulses of the LOCK LED accompanied by an audible tone.

To lock or unlock communication between the dispenser and main control board, press the LOCK pad and hold it for 3 seconds. The LOCK LED will flash while the LOCK pad is pressed. When the communication is locked, the LOCK LED will be illuminated.

The status of other functions selected prior to the initiation of the lock feature will be displayed. If the lock is engaged while a mode is active, the LED will remain on until that mode times out.

If the lock is engaged when the filter timer expires, the LED will come on but cannot be reset until the lock is turned off.

The lock feature will be restored in the event of a power disruption.

Liner Protection Mode

The dual evaporator model has separate liner protection modes for each section. The specific evaporator fan (freezer or fresh food) will start and run on high speed if the door has been open for 3 minutes.

This mode is controlled by 2 timers. Timer #1 monitors door-open time. A 3-minute door-open count begins when the door is opened. If 3 minutes elapse before the door is closed, the liner protection mode will become active. Once the door is closed, timer #1 resets and liner protection mode goes into standby. In standby, normal fan operation resumes and timer #2 begins a 3-minute door-closed count. If 3 minutes elapse without a door opening, liner protection mode will completely deactivate. If a door is opened within the timer #2 door-closed count, the remaining time in the door-closed count will be deducted from the timer #1 door-open count.

Components Locator Views

Rear View

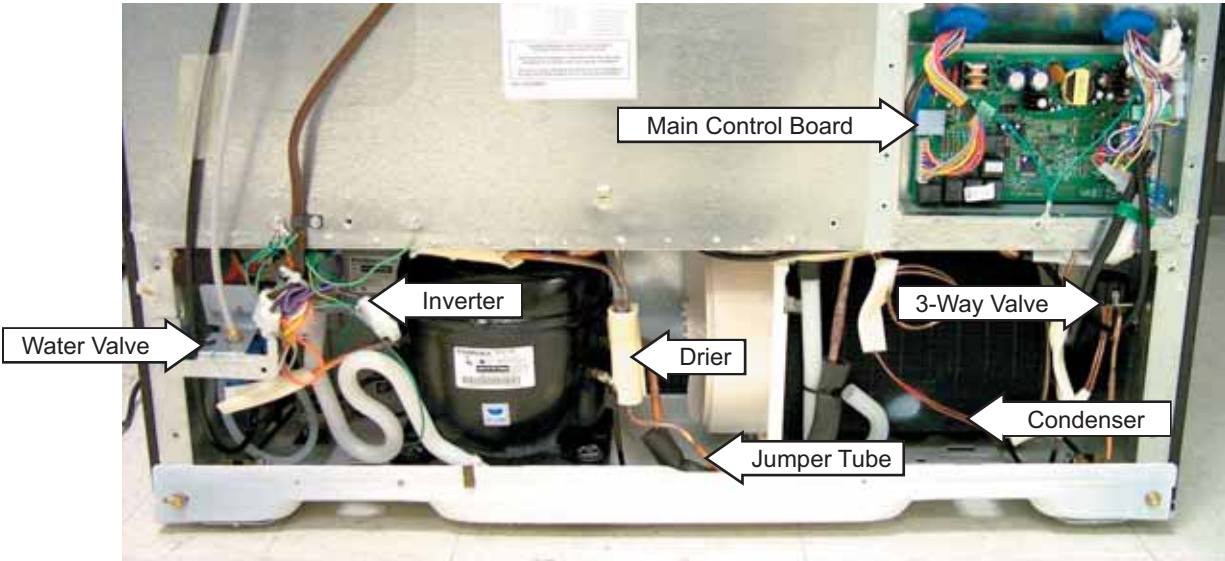

Front View

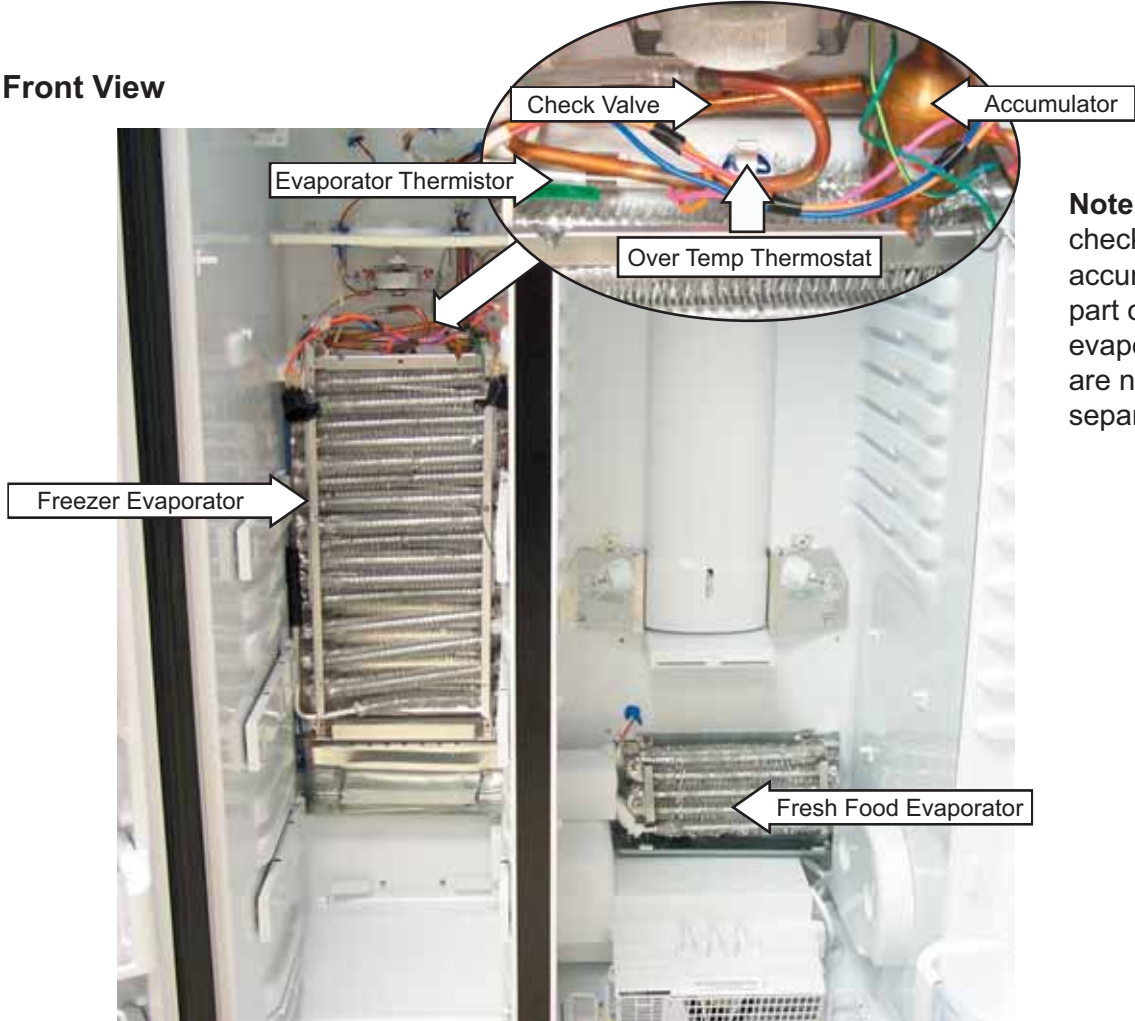

Note: The check valve and accumulator are part of the freezer evaporator and are not available separately.

Control Board Connector Locator

Main Control Board

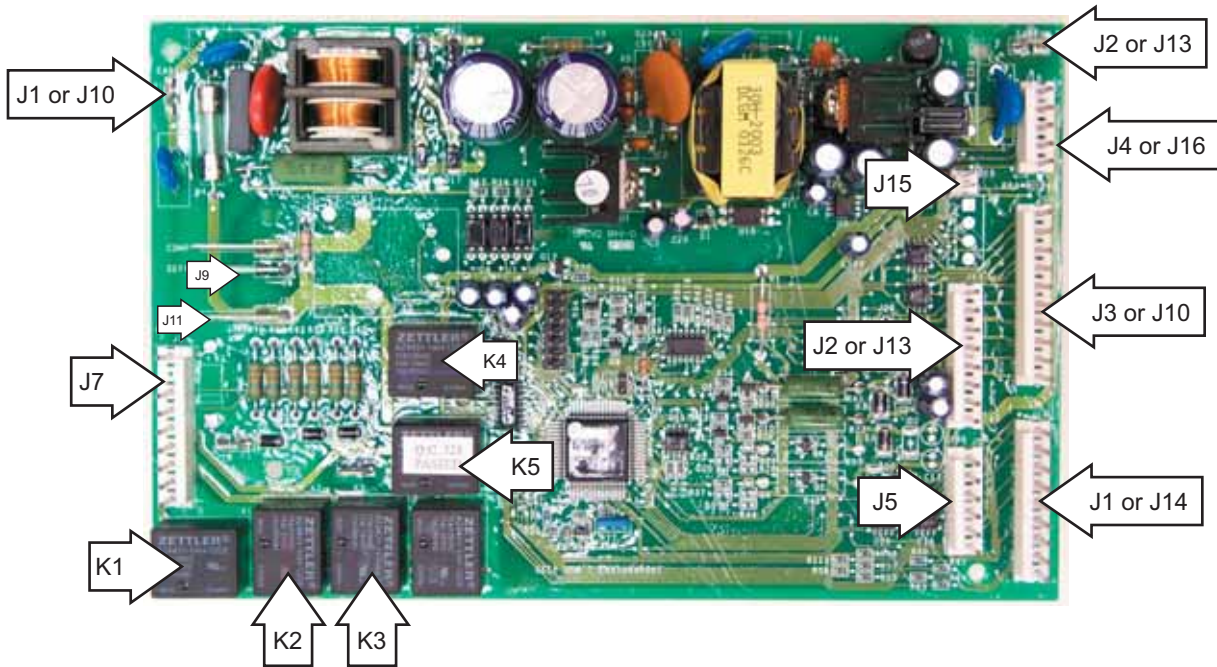

J1 or J10 - Earth (Ground)

J2 or J13 - Earth (Ground)

J5 - Custom Cool

J7 - Neutral, Door Switches, Custom Cool Heater, Water Valve, Crusher Solenoid, Auger Motor

J9 - Defrost Heater

J3 or J10 - 3-Way Valve

J11 - Line (L1)

J2 or J13 - Model Selector, Fan Common, Evaporator Fan, Condenser Fan, Fresh Food Fan, Custom Cool Fan

J1 or J14 - Fresh Food Thermistor, Freezer Thermistor, Fresh Food Evaporator Thermistor, Freezer Evaporator Thermistor, Model Selector

J15 - Inverter

J4 or J16 - Temperature Control Board

K1 - Auger

K2 - Crusher

K3 - Water

K4 - Defrost

K5 - Custom Cool

Some of the low voltage DC connector labeling on this model may differ from other models. The function and diagnostics for these connectors are identical for all models.

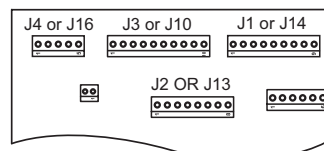

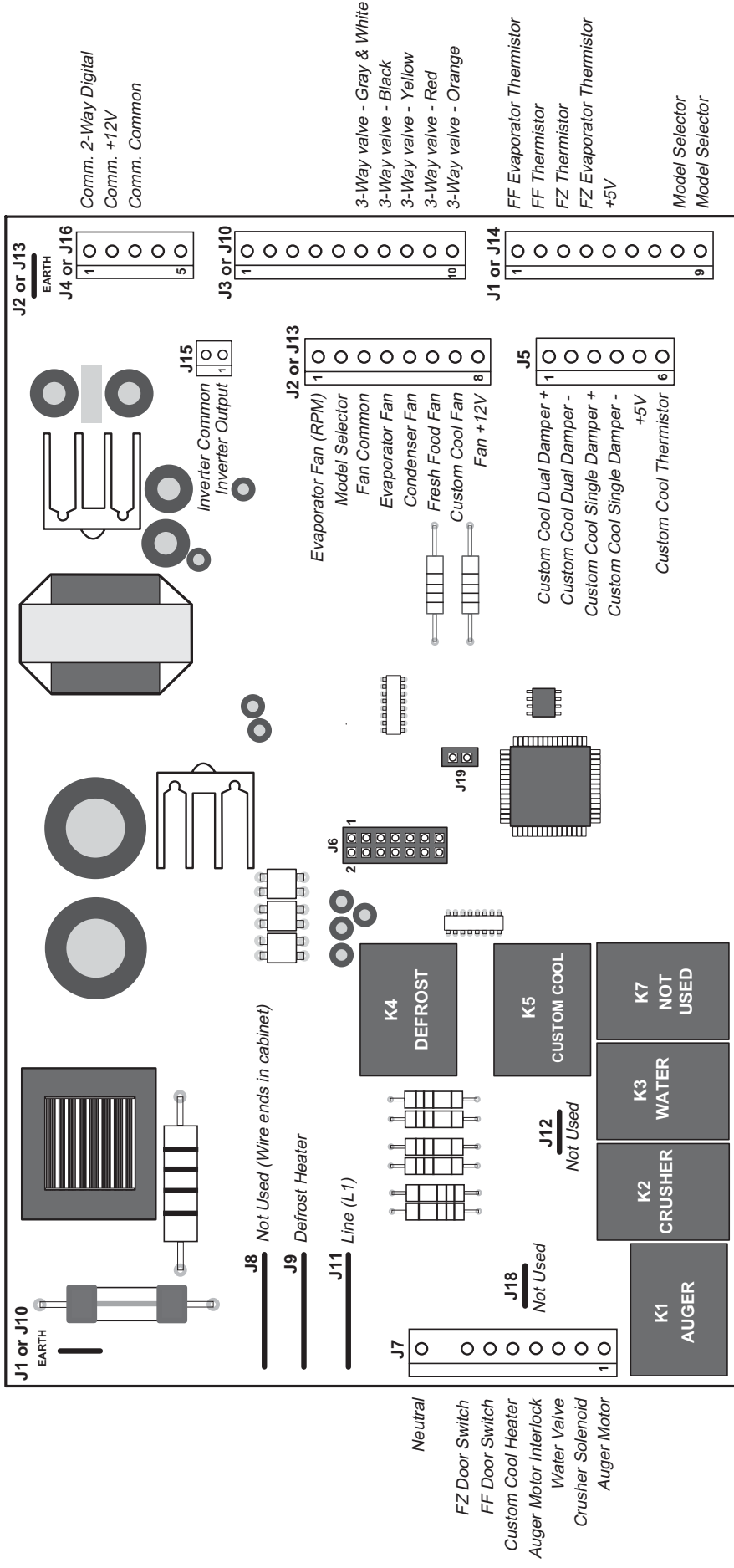

J2 or J13
EARTH
J4 or J16
1 5

Comm. 2-Way Digital
Comm. +12V
Comm. Common

J3 or J10
1 10

3-Way valve - Gray & White
3-Way valve - Black
3-Way valve - Yellow
3-Way valve - Red
3-Way valve - Orange

J1 or J14
1 9

FF Evaporator Thermistor
FF Thermistor
FZ Thermistor
FZ Evaporator Thermistor
+5V

J5
1 6

Custom Cool Dual Damper +
Custom Cool Dual Damper -
Custom Cool Single Damper +
Custom Cool Single Damper -
+5V
Custom Cool Thermistor

J2 or J13
1 8

Evaporator Fan (RPM)
Model Selector
Fan Common
Evaporator Fan
Condenser Fan
Fresh Food Fan
Custom Cool Fan
Fan +12V

J15
1 2

Inverter Common
Inverter Output

J6
1 2

K4
DEFROST

K5
CUSTOM COOL

K7
NOT USED

K3
WATER

K2
CRUSHER

K1
AUGER

J8 Not Used (Wire ends in cabinet)
J9 Defrost Heater
J11 Line (L1)

J12
Not Used

J18
Not Used

Neutral
FZ Door Switch
FF Door Switch
Custom Cool Heater
Auger Motor Interlock
Water Valve
Crusher Solenoid
Auger Motor

Refrigeration System

Fresh Food Section Cooling

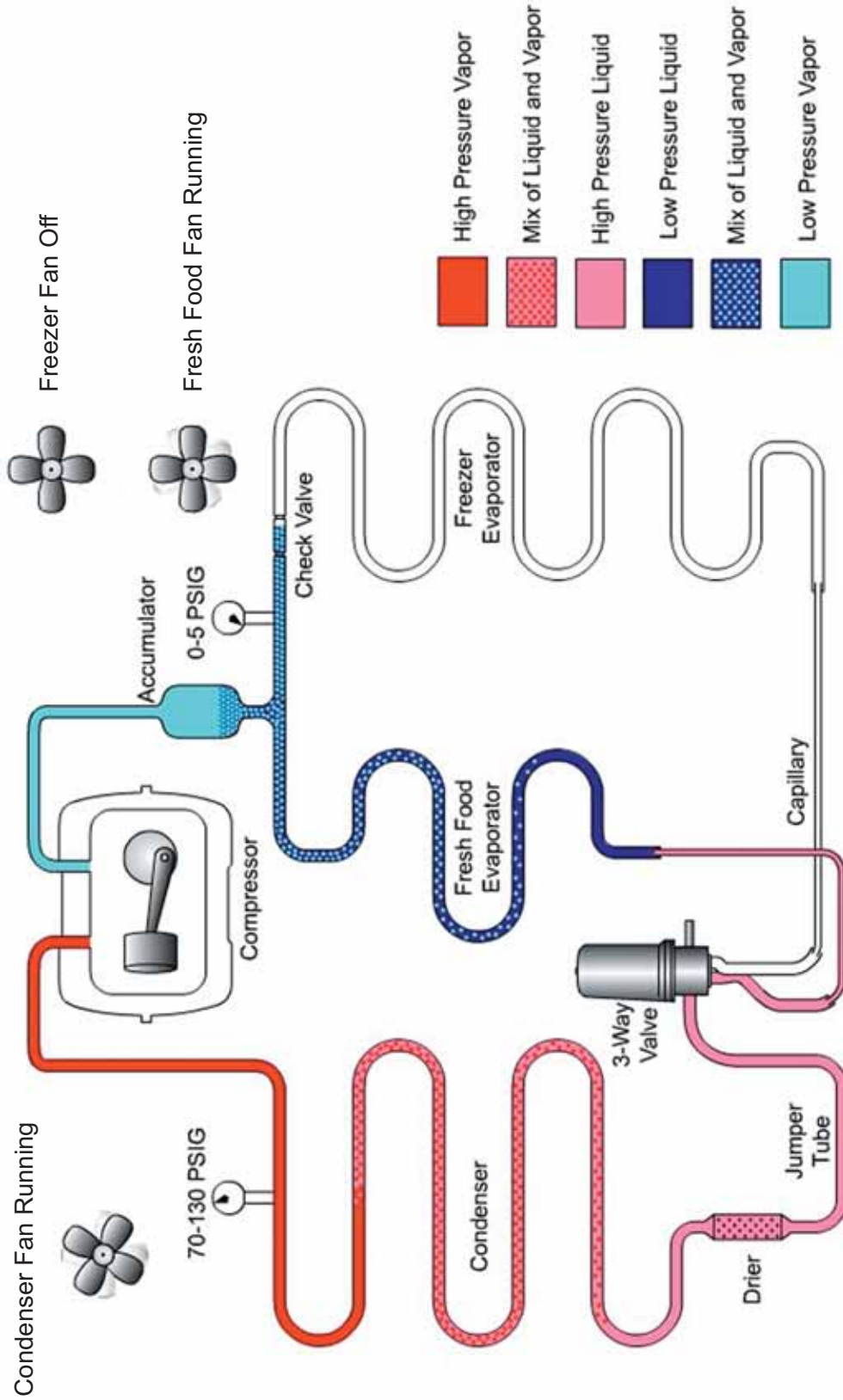

Freezer Section Cooling

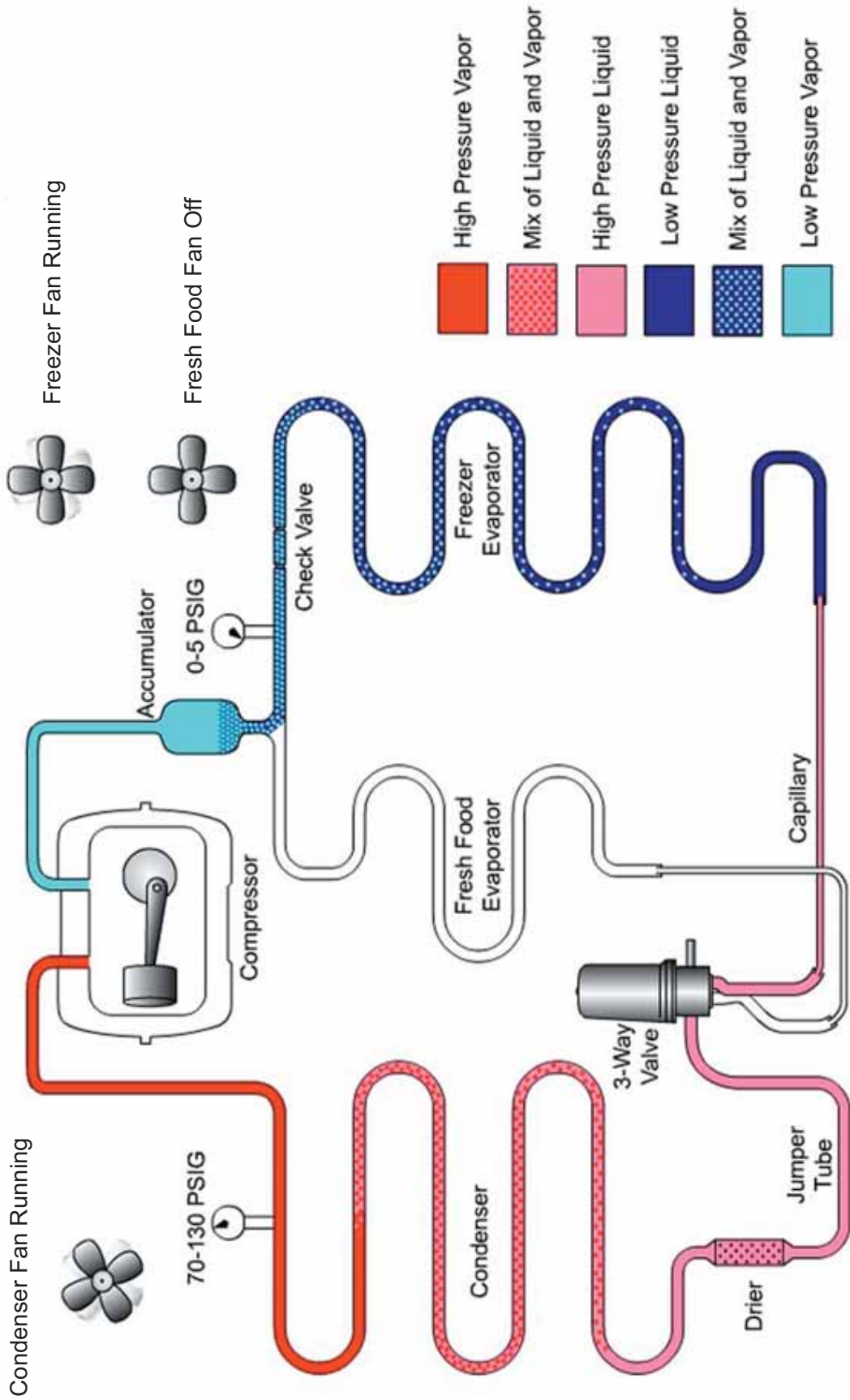

Fresh Food and Freezer Section Cooling

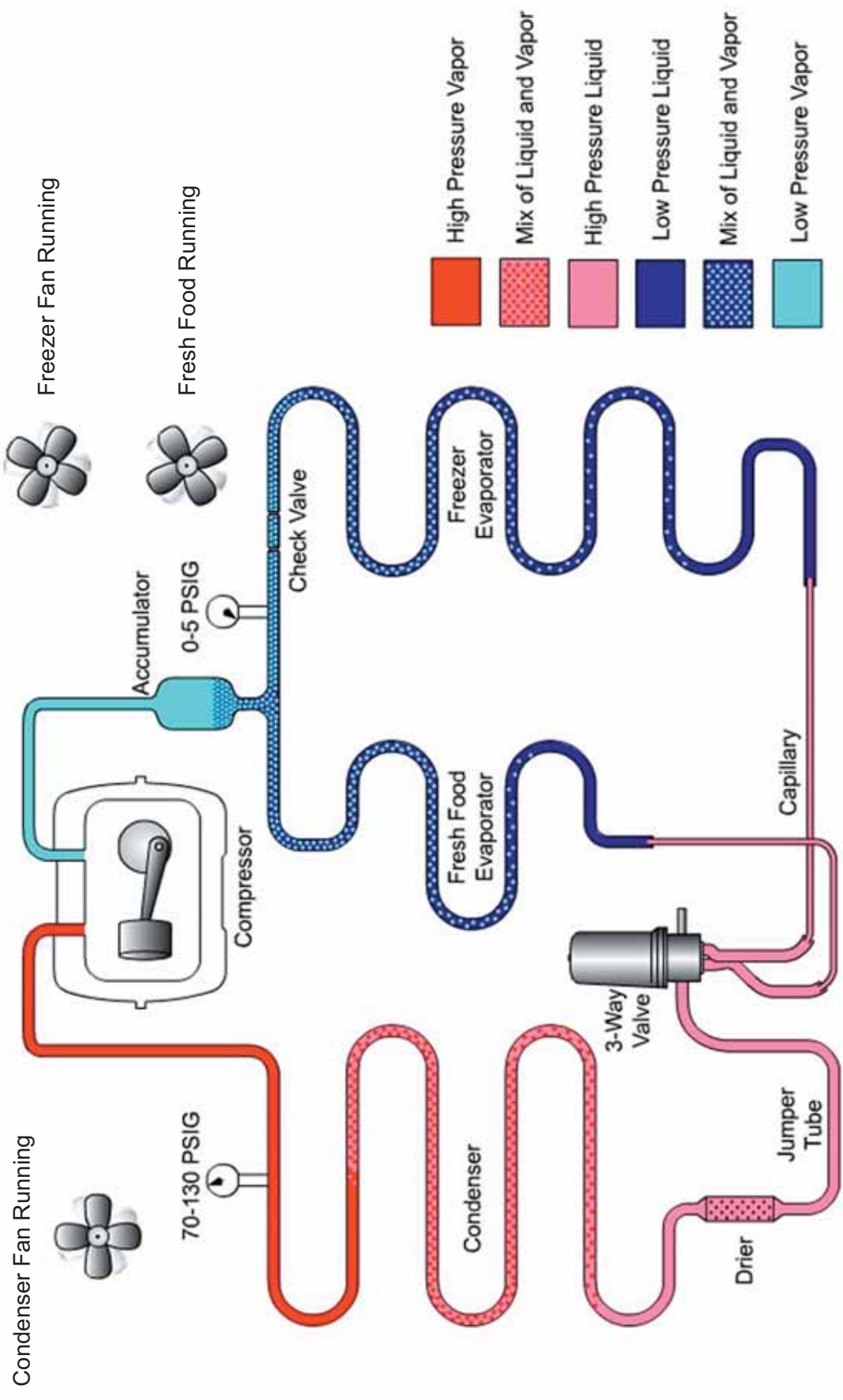

Evacuation and Charging Procedure

WARNING:

- Before cutting or using a torch on refrigerant tubes, recover the refrigerant from the system using approved recovery equipment.
 - Never charge new refrigerant through the purge valve. This valve is always located on the high pressure side of the system.
 - Never apply heat from any source to a container of refrigerant. Such action will cause excessive pressure in the container.
 - Always wear goggles when working with refrigerants and nitrogen holding charge in some replacement parts. Contact with these gases may cause injury.
1. Attach the hose from the R-134a charging cylinder to the process tube port on the compressor.
 2. Evacuate the system to a minimum 20-in. vacuum using the refrigerator compressor and recovery pump, which is attached to the new drier assembly.
 3. Turn off the recovery pump. Close the ball valve on the hose connected to the high-side port connection. Add 3 ounces of R-134a refrigerant to the system. Let the refrigerator operate and circulate the refrigerant for 5 minutes.
 4. Open the ball valve. Recover the purge/ sweep charge using the recovery pump and the refrigerator compressor until a 20-in. vacuum is attained. Close the ball valve and remove the recovery hose.
 5. Charge the system with the exact amount of R-134a refrigerant specified.
 6. Disconnect the power cord to the refrigerator. This allows the pressure to equalize. After 3 to 5 minutes, the low side pressure will be positive and then the hose-to-charging port can be disconnected.
 7. Using an electronic leak detector, check all brazed joints and both schrader ports. Reinstall caps to schrader.

Components

Thermistors

Thermistor Resistance		
Temperature (°F)	Temperature (°C)	Resistance in Kilo-Ohms
-40	-40	166.8 kΩ
-31	-35	120.5 kΩ
-22	-30	88 kΩ
-13	-25	65 kΩ
-4	-20	48.4 kΩ
5	-15	36.4 kΩ
14	-10	27.6 kΩ
23	-5	21 kΩ
32	0	16.3 kΩ
41	5	12.7 kΩ
50	10	10 kΩ
59	15	7.8 kΩ
68	20	6.2 kΩ
77	25	5 kΩ
86	30	4 kΩ
95	35	3.2 kΩ
104	40	2.6 kΩ
113	45	2.2 kΩ
122	50	1.8 kΩ
131	55	1.5 kΩ
140	60	1.2 kΩ

Note: To accurately test a thermistor, place the thermistor in a glass of ice water (approximately 33°F) for several minutes and check for approximately 16K Ω.

Fresh Food and Freezer Thermistors

The fresh food and freezer thermistors (part # WR5X10025) are located in the mullion dividing the fresh food and freezer compartments.

Note: The fresh food and freezer thermistors are removed in the same manner.

To remove the thermistor cover, insert a flat-blade screwdriver under the front of the cover and gently lift at the bottom edge until it releases from the compartment wall.

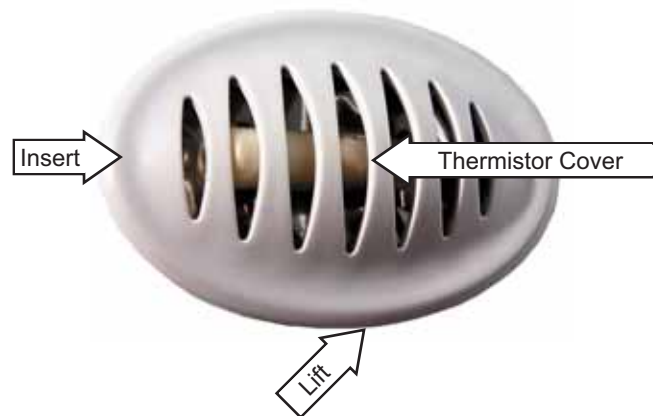

Freezer Evaporator Thermistor

The freezer evaporator thermistor (part # WR5X10025) is clipped to the top coil of the freezer evaporator. See **Freezer Evaporator** for accessing instructions.

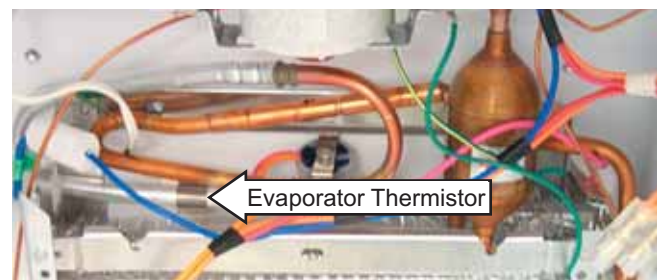

Fresh Food Evaporator Thermistor

The fresh food evaporator thermistor (part # WR55X10025) is located in an aluminum thermal block on the back of the evaporator. It is attached to the fresh food evaporator by a wire tie. See *Fresh Food Evaporator* for accessing instructions.

If the fresh food evaporator thermistor is either open or shorted, the main control board defaults to a fixed defrost cycle of 1 hour at high speed fan.

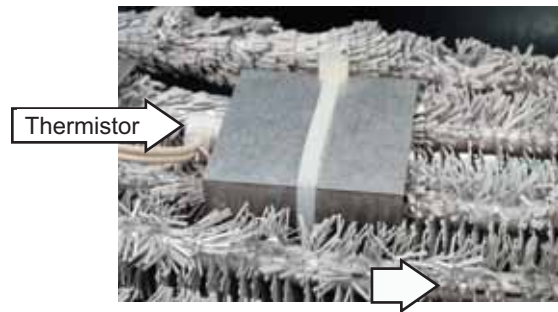
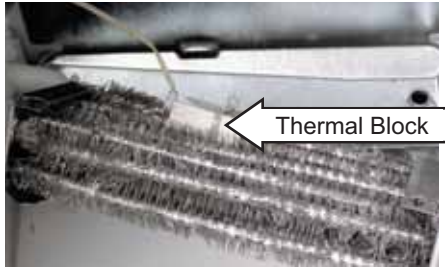

Barbs on the molded housing hold the thermistor in the thermal block.

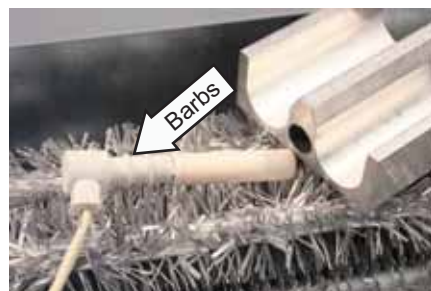

Replacement

Should the evaporator thermistor require replacement, splice a new thermistor into the harness using plastic bell connectors (part # WR01X10466). Fill the connector with RTV102 silicone as shown in the illustration.



Insert the new thermistor into the thermal block. Add RTV102 silicone to hold the thermistor in place. Make certain to wire tie the thermal block back to the evaporator.

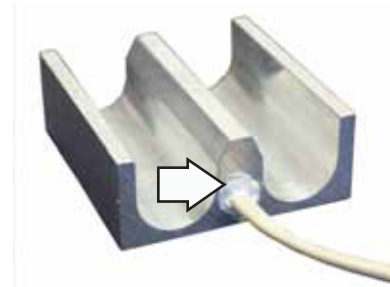

Fresh Food Evaporator Fan

A variable speed 12 VDC motor is mounted in front of the fresh food evaporator. The fan and evaporator cover are replaced as a complete assembly.



When activated, the fresh food evaporator fan recirculates the air in the fresh food compartment, providing cooling independent of the freezer evaporator fan.

The main control board gathers information from the fresh food thermistors to determine when, and at what speed, fan operation should occur.

A constant 13.6 VDC is provided to the fan from the main control board and switching occurs on the neutral side.

Speed is regulated by pulse width modulation on the common side of the fan. When operating, the common side of the circuit is pulsed open and closed. This pulsing produces effective voltage being received at the motor, which is equivalent to a reduction in voltage. Fan speed is selected and maintained by the main control board regulating the length and frequency of the 13.6 VDC pulse.

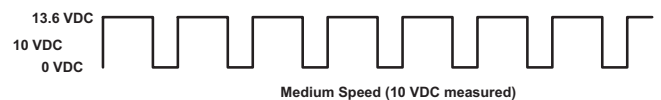
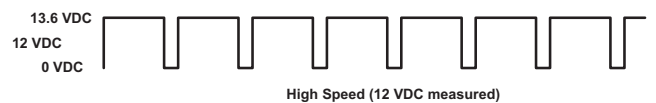

Freezer Evaporator Fan

The position of the fan blade in relation to the shroud is important.

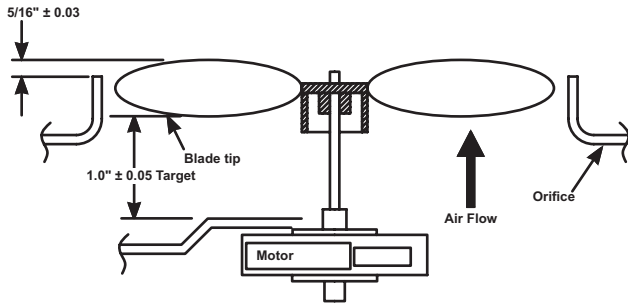

The evaporator fan is the same fan used on previous models; however, a significant difference is that the main control board neither requires nor receives input from the fan feedback/rpm (blue) wire. The fan utilizes a permanent magnet, 4 pole, DC motor that operates at three different speeds: high, medium, and low.

The speed of the fan is controlled by the voltage output from the main control board. Voltage output from the main control board to the fan is 13.6 VDC; however, to regulate the speed of the fan, the main control board uses pulse width modulation (PWM).

When operating, voltage is sent in pulses (much like a duty cycle) as opposed to an uninterrupted flow. This pulsing of 13.6 VDC produces effective voltage being received at the motor, which is equivalent to a reduction in voltage.

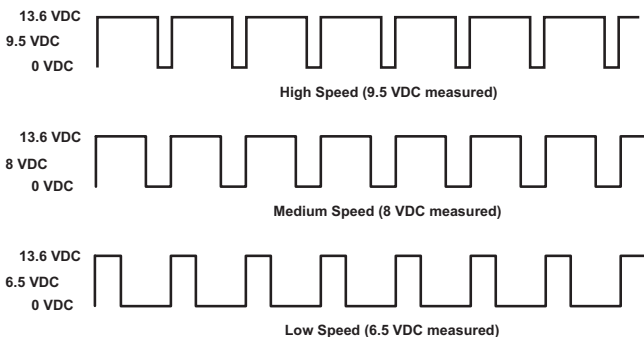

Fan speed is selected and maintained by the main control board regulating the length and frequency of the 13.6 VDC pulse. Temperature can cause some fan speed variation. Fan speed can vary +/- 5%, depending on the temperature, with higher temperatures causing slightly higher speeds.

The evaporator fan has a 4-wire connection:

White Wire (DC Common)

The white wire is the DC common wire used for testing. During repairs, DC polarity must be observed. Reversing the DC polarity causes a shorted motor and/or board.

Red Wire (Supply)

Each motor uses an internal electronic controller to operate the motor. Supply voltage from the main control board remains at a constant 13.6 VDC.

Blue Wire (Feedback/RPM)

On previous Arctica models, the blue wire reported rpm (speed) information to the main control board for speed control purposes. On this model, the board does not require or read any feedback information from the fan motor.

Yellow Wire (Signal)

The yellow wire is the input wire from the main control board. The main control board provides 6.5 VDC effective voltage for low speed, 8 VDC effective voltage for medium speed, and 9.5 VDC effective voltage for high speed. The fan operates in low speed only when the fresh food thermistor is satisfied.

Note: When testing these motors:

- You cannot test with an ohmmeter.
- DC common is not AC common.
- Verify 2 voltage potentials:
 - a. Red to white - power for internal controller
 - b. Yellow to white - power for fan
- Observe circuit polarity.
- Motors can be run for short periods using a 9 volt battery. Connect the white wire to the negative (-) battery terminal only. Connect the red and yellow wires to the positive (+) battery terminal.

Condenser Fan

The fan is mounted in the machine compartment with the no-clean condenser. The fan and fan shroud are mounted on one end of the condenser, and the other end of the condenser is blocked.

When the fan is operating, air is pulled from the center of the condenser, drawing air in through the coils. The air is then exhausted over the compressor and out the right side of the refrigerator.

Inlet air is available through the left front and left rear of the machine compartment. A rubber divider strip underneath the refrigerator divides the inlet and outlet sides of the machine compartment.

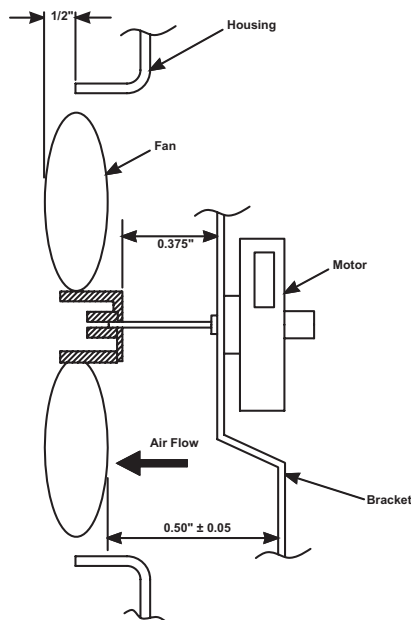
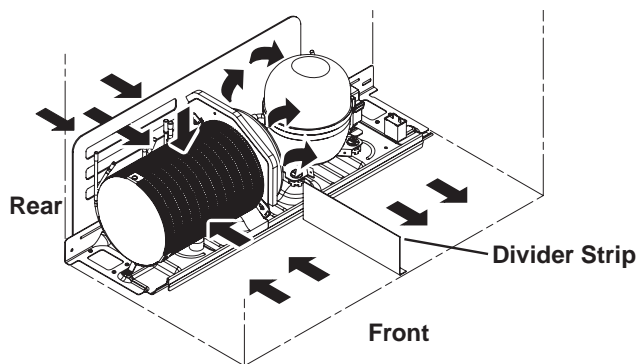

The rear access cover must be tightly fitted to prevent air from being exhausted directly out of the rear of the machine compartment, bypassing the compressor.

The condenser fan is mounted with screws to a fan shroud and mounting bracket that is attached to the condenser.

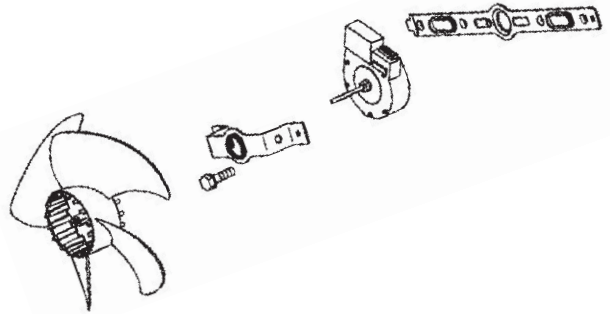

Condenser fan speed corresponds with compressor speed (low, medium, high) to minimize pressure variations in the sealed system except when the freezer temperature is 20°F above the set point. If this condition exists (such as during initial startup), the condenser fan operates at super high speed while the compressor operates at medium speed.

The speed of the fan is controlled by the voltage output from the main control board. Voltage output from the control board to the fan is 13.6 VDC; however, to regulate the speed of the fan, the main control board uses pulse width modulation (PWM).

When operating, voltage is sent in pulses (much like a duty cycle) as opposed to an uninterrupted flow. This pulsing of 13.6 VDC produces effective voltage being received at the motor, which is equivalent to a reduction in voltage.

Fan speed is selected and maintained by the main control board regulating the length and frequency of the 13.6 VDC pulse.

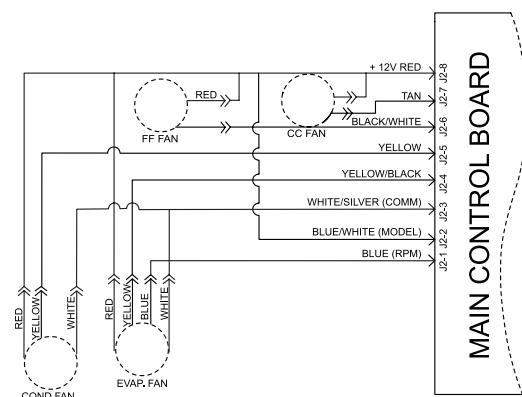

Temperature can cause some fan speed variation. Fan speed can vary +/- 5%, depending on the temperature, with higher temperatures causing slightly higher speeds.

Condenser fan speed is controlled by Pulse Width Modulation (PWM), the same method used to control fan speeds for the evaporators.

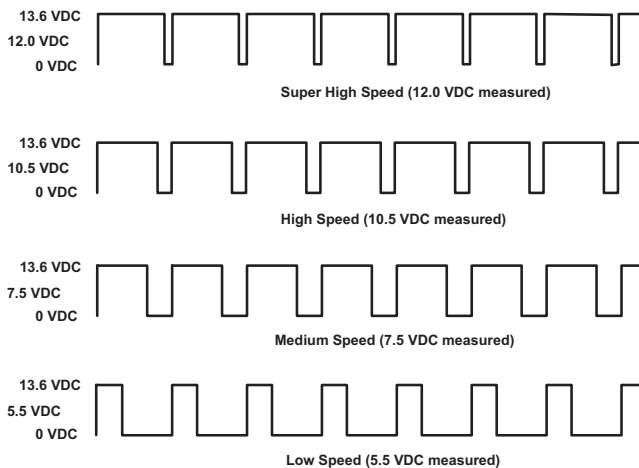

Fresh Food Normal Defrost

The fresh food section cools until the fresh food thermistor is satisfied.



If both freezer and fresh food thermistors are satisfied, the compressor cycles off. If the freezer still requires cooling, the main control board rotates the 3-way valve to stop refrigerant flow to the fresh food evaporator. Even though refrigerant flow has stopped in the fresh food evaporator, the fresh food fan continues to run at low speed.

The system is designed to run the fan until the fresh food evaporator thermistor reaches 35°F.

Defrost Cycles

Fresh Food Evaporator Defrost Cycle

The refrigerator utilizes a forced air cycle defrost method (no electric heater) to remove frost from the fresh food evaporator. Fresh food air that is above freezing temperature circulates thru the coil and melts any accumulated frost. Note that during fresh food defrost, the compressor may still be running, cooling only the freezer section.



Once this temperature is reached, the fan continues to run for an additional 5 minutes. Under normal conditions, the defrost time takes approximately 30 minutes. The maximum time the fan runs in low speed is 60 minutes. If the evaporator thermistor has not reached 35°F after 60 minutes, the control switches to extended defrost #1.

Fresh Food Extended Defrost #1

Occasionally there may be excessive frost on the evaporator coil. This can be attributed to numerous door openings, extremely high humidity, poor door gasket seal, etc. If the normal defrost fan time exceeds 60 minutes, the fan switches to high speed. The control continues to monitor the fresh food evaporator thermistor for 35°F. When 35°F is reached, the fan runs for an additional 5 minutes at high speed. The fan can run up to an additional 30 minutes at high speed, trying to reach 35°F. After 90 total minutes of fan time (60 at low speed and 30 at high speed), if the fresh food evaporator is still below 35°F, the control will switch to extended defrost #2.

Fresh Food Extended Defrost #2

If the fresh food fan has been operating for 90 minutes, the main control searches for a fresh food thermistor temperature above 52°F. If the fresh food thermistor is above 52°F, the main control board assumes there is a problem reading the fresh food evaporator thermistor, ends the defrost cycle and returns to normal cooling.

If the fresh food thermistor is less than 52°F, the main control board assumes there is refrigerant leaking through the 3-way valve, keeping the fresh food evaporator cold during the defrost process while the freezer evaporator is cooling. The main control board shuts off the compressor and runs the fresh food fan at high speed until two conditions are met: the evaporator thermistor reaches 35°F and the fresh food thermistor is 2½°F above the set point. As in the other cycles, the fan continues to run for an additional 5 minutes after the 35°F evaporator temperature is reached.

Fresh Food Forced Defrost

If the main control board senses the fresh food section has been cooling for 45 minutes, it immediately stops the refrigerant flow through the fresh food evaporator. The main control board changes the position of the 3-way valve if cooling is still required in the freezer, or turns the compressor off if the freezer is satisfied. The fresh food fan operates on high speed until the evaporator reaches 35°F, plus an additional 5 minutes after the evaporator reaches 35°F.

To prevent the refrigerator from going into forced defrost when first installed or after a power failure, the control will disregard the 45 minute time limit if the freezer temperature is above 20°F.

Note: If the fresh food evaporator thermistor is either open or shorted and the 35°F cutoff cannot be determined, the main control board defaults to a fixed defrost cycle of 1 hour at high-speed fan.

Freezer Defrost Cycle

The freezer evaporator utilizes a defrost heater to remove frost from the coil. The control board determines the length of time the heater is energized. It does this by monitoring the freezer evaporator thermistor. Once the temperature of the thermistor reaches 75°F, the control cycles the defrost heater off. A bi-metal safety thermostat provides a backup in the event the evaporator thermistor fails. The safety thermostat prevents the temperature from exceeding 140°F.

Note: During the freezer defrost cycle, the compressor does not operate, even if the fresh food section is above the set point.

Inverter

- The inverter is accessed from the back of the refrigerator.
- It is located on the left side of the compressor behind the water valve.
- The water valve must be removed to access the inverter.

To remove the Inverter

1. Remove the 1/4-in. hex-head screw that holds the inverter in place.

Inverter Viewed From the Front

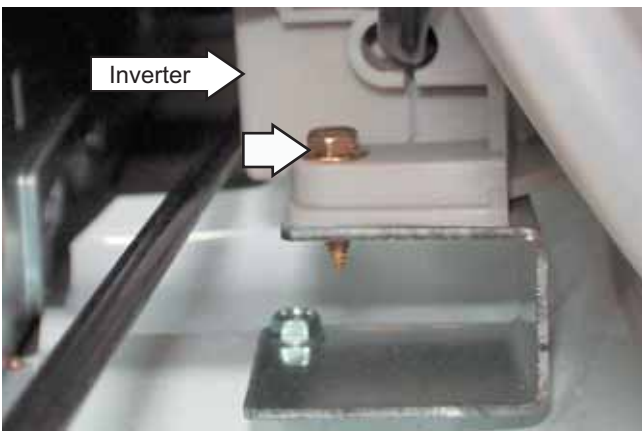

2. Rotate the inverter counterclockwise and slide it forward to release the tabs from the mounting bracket.

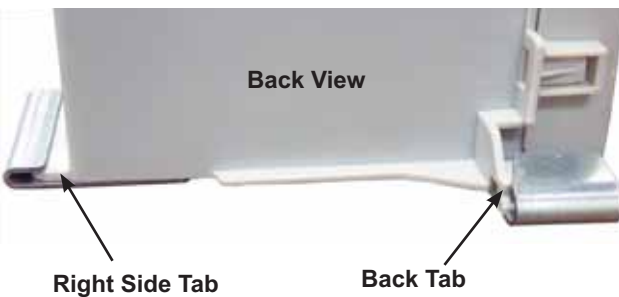
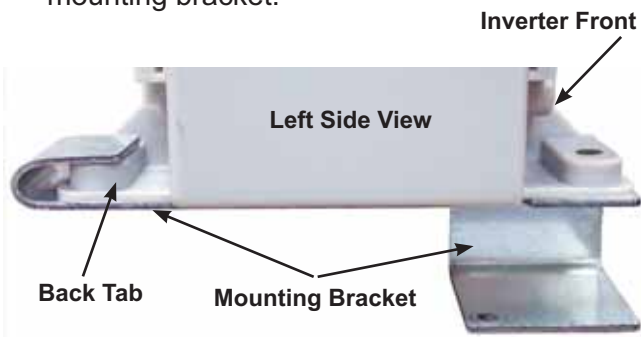

Caution: It may be necessary to bend the process tube in order to remove the inverter. If it is necessary to bend the process tube, use extreme caution.

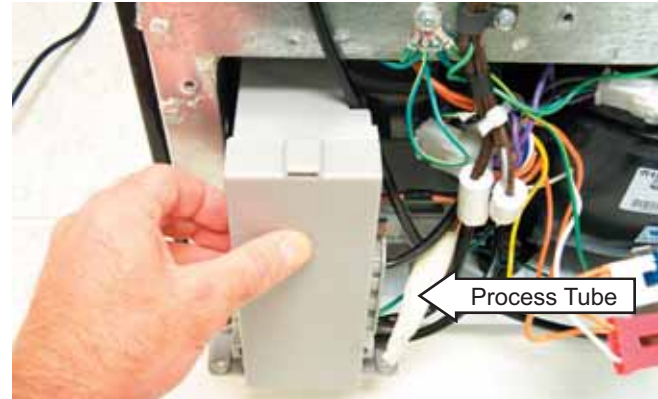

Inverter Shown with Cover Removed

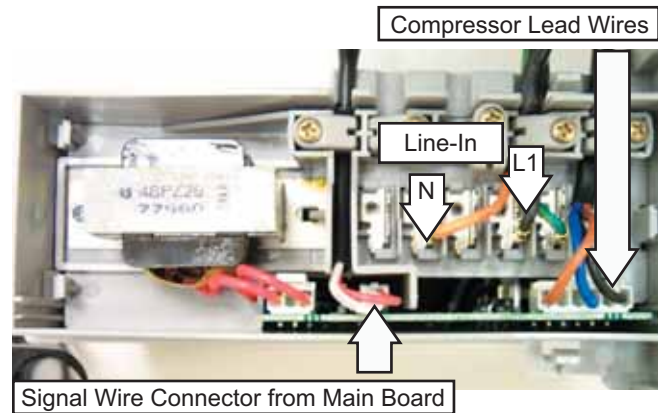

WARNING: When the refrigerator is plugged in, 120 VAC is always present at the inverter.

Note: Certain voltmeters will not be able to read voltage output from the inverter. If no voltage or erratic voltage is measured, it does not necessarily indicate a faulty inverter.

The inverter receives 120 VAC line-in from the power supply. The inverter converts this single-phase, 60 Hz, 120 VAC into 3-phase, 230 VAC, with frequency variations between 57 Hz and 104 Hz. This voltage is delivered to the compressor through 3 lead wires. Each wire will carry identical voltage and frequency.

Note: The compressor leads must be connected to measure voltage output. If the compressor wires are not connected, or if an open occurs in one of the 3 lead wires or in the compressor, the inverter will stop voltage output.

When checking inverter voltage output, connect the test-meter leads to any 2 of the 3 compressor lead wires at the inverter plug (plug should be connected). The same reading should be measured between any 2 of the 3 wires.

The inverter controls compressor speed by frequency variation and by Pulse Width Modulation (PWM). Changing frequency and PWM will cause an effective voltage between 80 and 230 VAC to be received at the compressor.

- Low speed (1710 rpm) - 57 Hz
- Medium speed (2100 rpm) - 70 Hz
- High speed (3120 rpm) - 104 Hz

The inverter receives commands from the main control board. The main control board will send a PWM run signal from the J15 connector of between 4-6 VDC effective voltage to the inverter (all wires must be connected). The inverter will select compressor speed (voltage output) based on this signal.

The main control board will only send a run signal to the inverter when the compressor should be on.

Note: When measuring signal voltage (from the main control board) at the inverter, a reading of 4-6 VDC will be measured with all wires connected. If the inverter wiring is disconnected, the board output will measure between 10-12 VDC.

The inverter will monitor compressor operation and if the compressor fails to start or excessive current draw (4 amps maximum) is detected, the inverter will briefly stop voltage output. The inverter will then make 12 consecutive compressor start attempts (once every 12 seconds). After 12 attempts, if the compressor has not started, an 8-minute count will initiate. After the 8-minute count, the inverter will attempt to start the compressor again. If the compressor starts, normal operation will resume. If the compressor fails to start, this process will be repeated. Removing power to the unit will reset the inverter count. When power is restored, the inverter will attempt to start the compressor within 8 seconds.

The inverter has a built-in circuit protection to guard against damage from a failed or shorted compressor. However, if a failed compressor is diagnosed, order a new compressor and inverter. If the compressor fails to start after replacement, replace the inverter.

Inverter Compressor

Caution: Do not attempt to direct-start the compressor. The compressor operates on a 3-phase power supply. Applying 120 VAC to the compressor will permanently damage the unit. It is not possible to start the compressor without an inverter.

The compressor is a reciprocating, variable speed, 4-pole type. It operates on 3-phase, 80 to 230 VAC within a range of 57 to 104 Hz.

Note: Certain voltmeters will not be able to read voltage output or frequency from the inverter.

Compressor wattages at various speeds are:

- LOW - 65 watts
- MED - 100 watts
- HIGH - 150 watts

The compressor is controlled by the inverter, which receives its signal from the main control board. Varying the frequency to the inverter changes the compressor speed.

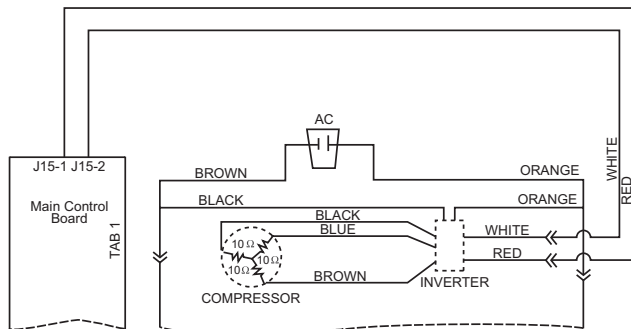

Compressor speed is based on the temperature set point in conjunction with the specific cabinet temperature. Speeds are selected according to the following cabinet temperatures, with freezer temperature being the primary:

- 7°F to 19.5°F above freezer set point = high speed.
- 4.5°F to 6.5°F above freezer set point = medium speed.
- 1°F to 4°F above freezer set point = low speed.
- 1°F to 2.5°F above refrigerator set point = low speed.

- 3°F to 5°F above refrigerator set point - medium speed.
- 5.5°F to 7°F above refrigerator set point - high speed.

Note: The compressor will run at medium speed if the freezer temperature is 20°F or more above the setpoint.

The use of 3-phase power eliminates the need for the PTCR relay, capacitor, and individual start and run windings; therefore, the start, run and common pins found on conventional compressors are not applicable on this 3-phase model. Compressor pin functions are identical and compressor lead wire configuration is of no importance. A resistance of 9Ω to 11Ω should be read between any 2 of the 3 pins. Should an open occur in the compressor winding or should one of the compressor lead wires become open or disconnected, the inverter will stop voltage output to the compressor.

High compressor torque enables the compressor to start against high pressure in the sealed system. When power has been disconnected from an operating unit, the high torque will enable the compressor to start immediately upon power restoration.

Compressor and sealed system operation is extremely smooth and cool. The compressor exterior may be room temperature while operating; therefore, a running unit may be difficult to detect.

To verify that the compressor is running:

Disconnect power from the unit and place a hand on the compressor. Reconnect power and feel for a vibration when the compressor tries to start. It may take up to 8 seconds before the compressor attempts to start.

Note:

- When ordering a replacement compressor, order both the compressor and inverter. Replace the compressor first. If, after compressor installation, the compressor fails to start, replace the inverter.
- When servicing the compressor, it is important to dress the wiring to keep low voltage DC wiring and 120 VAC wiring separate.

3-Way Valve

The 3-way valve is located beneath the main control board in the machine compartment and is accessed from the back of the refrigerator. It is composed of a magnetic coil and a valve body. Two ¼-in. hex-head screws mount the valve to the cabinet.

- Make certain that rubber gaskets are installed on mounting bracket to reduce vibration.

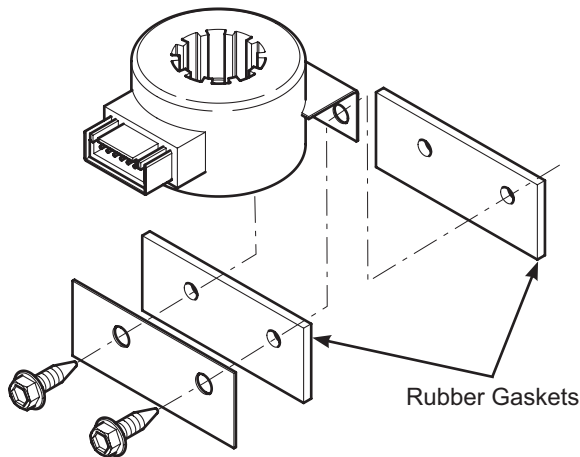

- Three copper tubes connect to the 3-way valve.
- One jumper tube connects from the drier to the inlet on the valve.
- A freezer capillary and a fresh food capillary connect to the other two tubes on the valve.

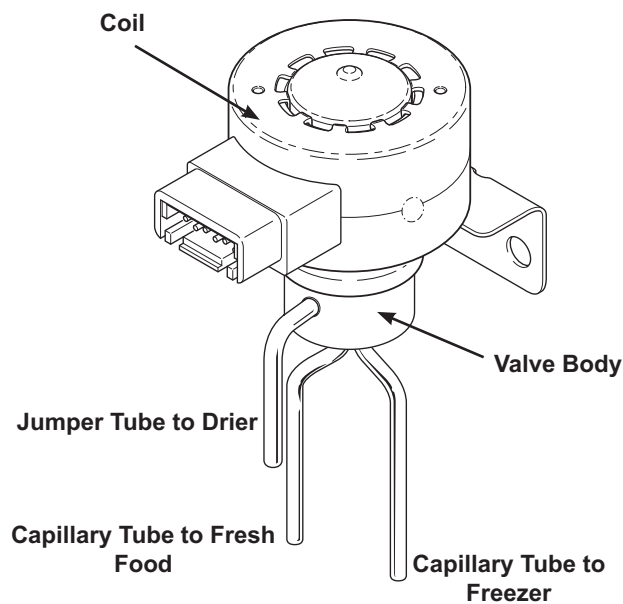

3-Way Valve Coil

The 3-way valve coil receives 12 VDC pulses from the main board to change the position of the valve. The pulses come too quickly to measure with a volt meter.

The 3-way valve coil has a resistance value of approximately 46 ohms that can be measured between the coil pins.

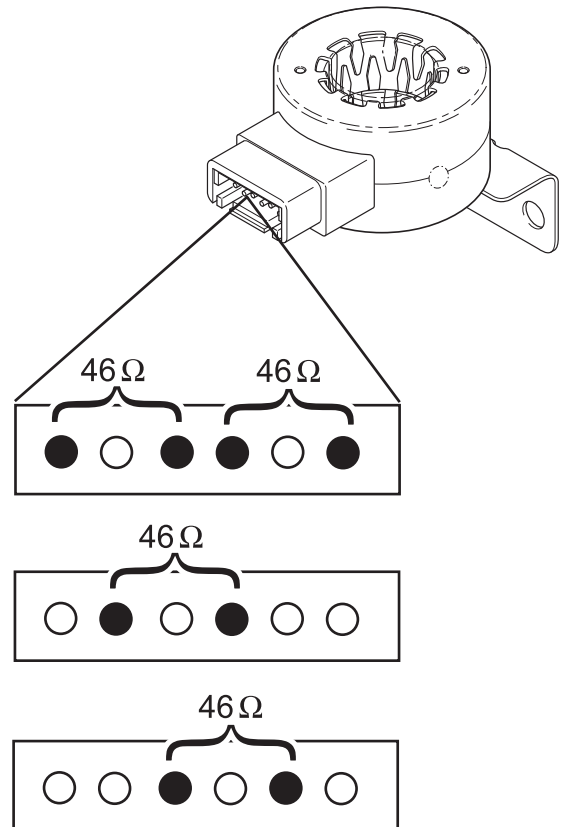

3-Way Valve Body

- The valve body contains a cam, rotor and magnet.
- The rotor and cam are grooved to rotate with the magnet.
- The entire valve body has refrigerant flowing through it when the compressor is operating.
- Use care not to damage the top of the valve body when installing the coil on the valve.
- A locating pin is used to correctly align the valve body in the valve coil.
- Failure to fully seat the valve in the coil or to align it correctly with the pin can cause the system to stop cooling.

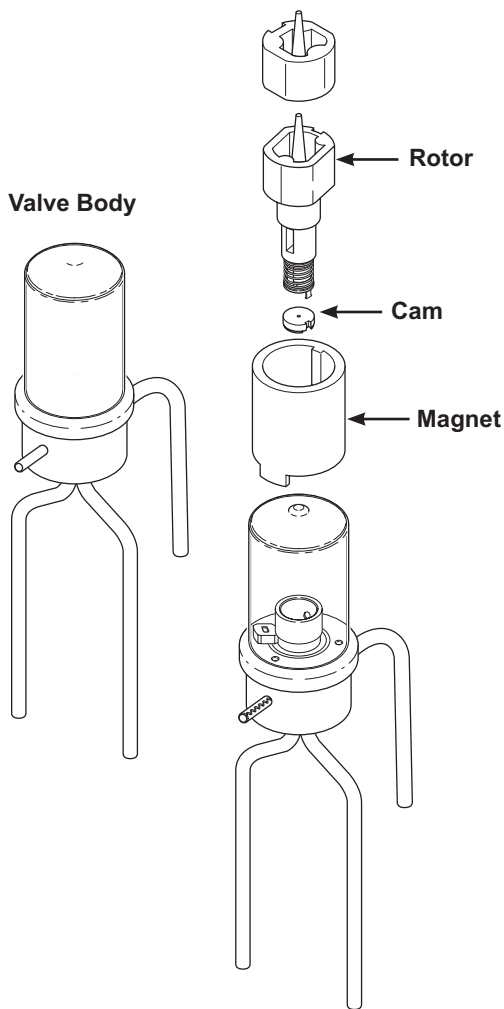

Valve Rotation

- The pulses of the valve coil cause the magnet to rotate inside the valve body.
- As the magnet rotates, it moves the cam at the bottom of the valve.

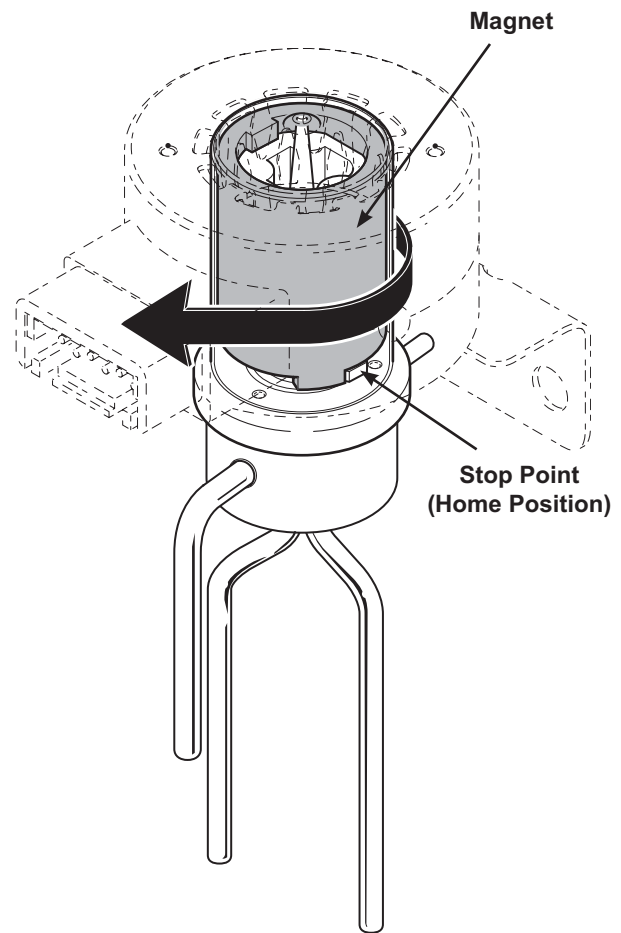

The cam opens or covers the ports to the capillary tubes.

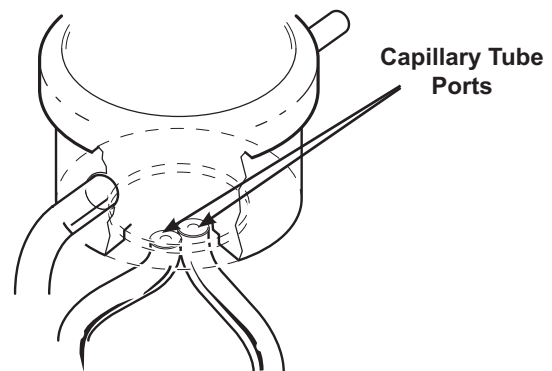

Note: The 3-way valve comes only as a complete assembly. Exploded view is for reference only.

Testing the 3-Way Valve

The valve returns to “home” at the end of every freezer defrost cycle and whenever the refrigerator is reconnected to power.

To test the valve, disconnect the refrigerator from power for at least 10 seconds, place a finger on top of the valve and reconnect power.

The main control overdrives the valve to the “home” position.

You should be able to feel the valve move as it returns to the home position .

If movement is present, the main board and valve coil are operating correctly.

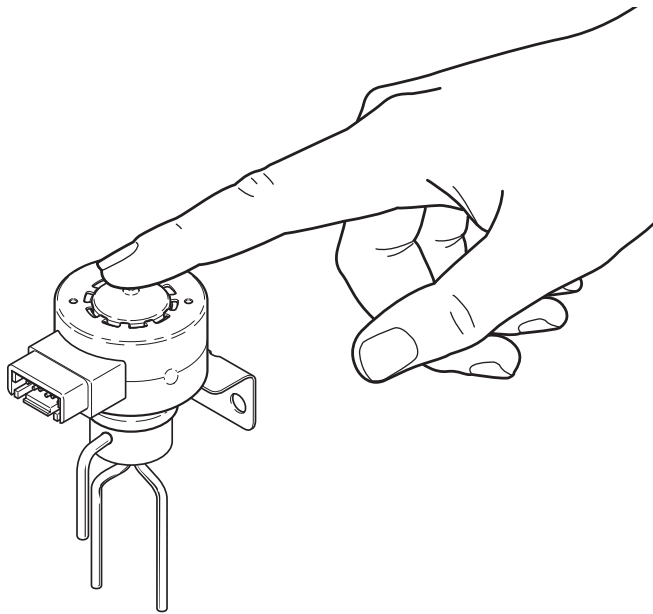

Replacing the 3-Way Valve

Parts Needed:

- 3-Way Valve (part # WR57X10053)
- Thermal Paste (part # WX5X8927)
- Drier Assembly (part # WR86X93)
- Process valve (part # WJ56X61)

When replacing a 3-way valve, note the black mark on the freezer outlet tube. Make certain to mark the freezer capillary by placing a piece of tape on the capillary, 6-8 inches from the valve. This will aid in installing the capillaries in the correct outlet tubes.

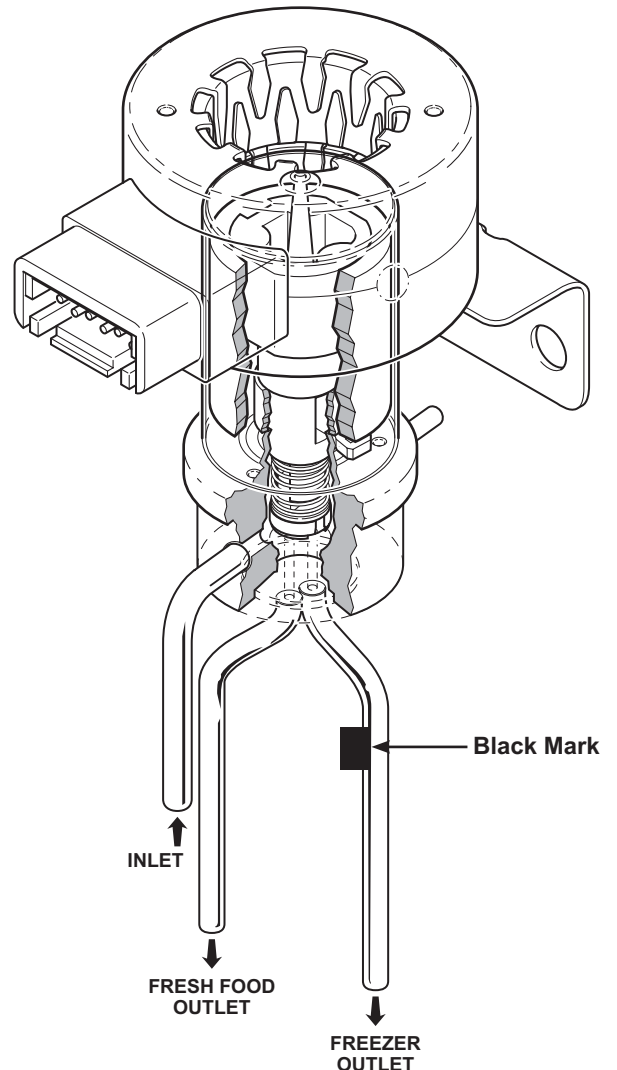

1. Unplug the refrigerator.
2. Remove the rear access cover and evacuate the sealed system. (See **Evacuation and Charging Procedure.**)
3. Remove the valve body from the valve coil by carefully pressing down on top of the valve body.

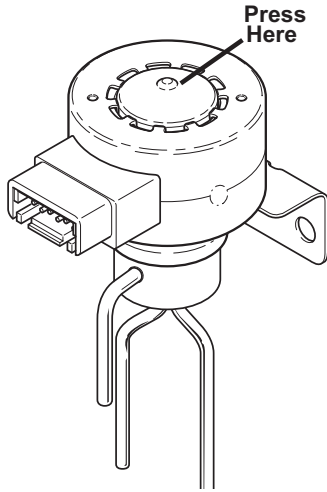

5. Connect the new jumper tube to the inlet tube of the new 3-way valve.
6. Prepare the taped capillary tube, and insert it into the 3-way valve freezer outlet port (identified with black mark or tape).
7. Prepare the remaining capillary tube and insert it into the 3-way valve fresh food outlet port.

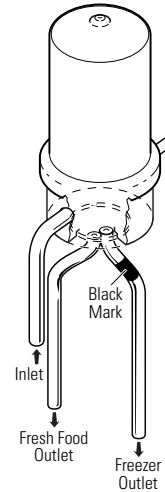

4. Tape the freezer capillary tube 6 inches below the brazing joint. Score and break the two capillary tubes below the brazing joints.

8. Apply a liberal amount of thermal paste to the base of the three tubes on the new valve. Apply a wet cloth to the top of the valve to help keep the valve cool.

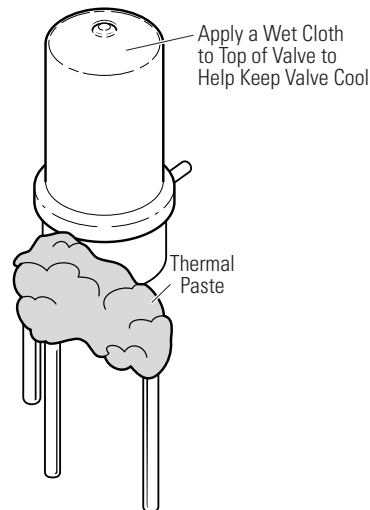
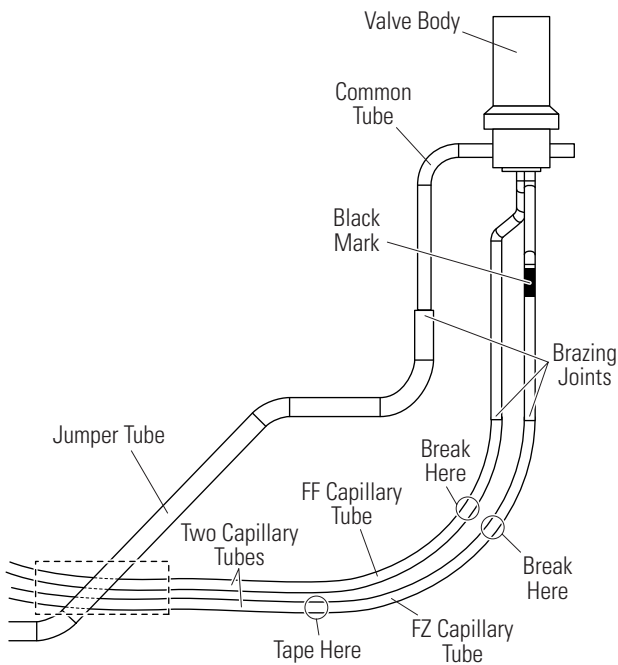

9. Angle the torch so the flame is not directed towards the valve body when brazing the three joints.
10. Remove the thermal paste residue and dry the valve body thoroughly. Install the valve body into the coil.

Note: If necessary, use an adjustable pliers to carefully install the valve body into the coil. DO NOT depress on the top of the valve body. See photo.



11. Remove the old drier by un-brazing or cutting the condenser loop (halo) as close as possible to the drier. Install the new drier assembly (part # WR86X93).

Note: If necessary, use the condenser loop extension tubing (part # WR97X238).

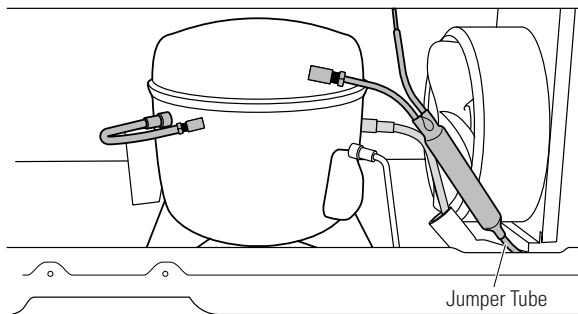

12. Install the process valve (part # WJ56X61). Clean and inspect all joints.
13. Evacuate and charge the system. Use original factory charge quantity of R-134a. (See **Evacuation and Charging Procedure.**)
14. Reinstall the rear access cover.

Freezer Evaporator

The following components must be removed in the appropriate order to access the freezer evaporator:

1. Remove the ice bucket, shelves, and drawers.
2. Slide the air duct panel upward to remove.



3. Remove the light bulb cover and light bulbs.
4. Remove the four 1/4-in. hex-head screws that hold the auger assembly in place.
5. The auger motor wiring is connected in two places:
 - a. Disconnect the top connector.

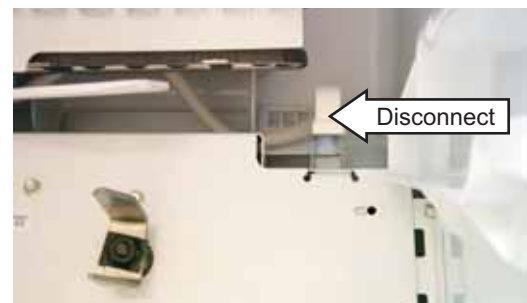

- b. Pull the auger motor assembly forward and disconnect the second connector.

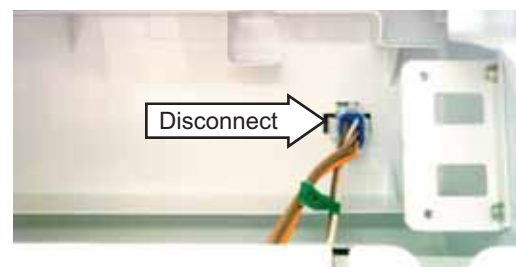

6. Loosen the 2 screws that hold the icemaker assembly in place and slide it out of the freezer compartment.

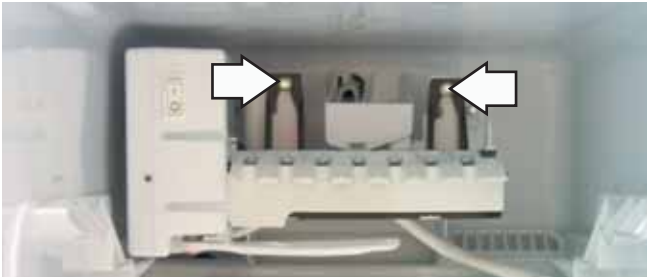

7. Loosen the 3 screws on the icemaker bracket, and slide it out of the freezer compartment.



8. Unclip the light bulb sockets from their mounting holes and disconnect the sockets.



9. Remove the 4 hex-head screws that hold the freezer evaporator cover in place. Carefully pull the evaporator cover out of the freezer compartment.

10. Remove the 4 hex-head screws that hold the evaporator fan shroud in place (Fig. 1 and Fig. 2).



Fig. 1

Note: The bottom hex-head screws are hidden under the bottom of the evaporator fan shroud.

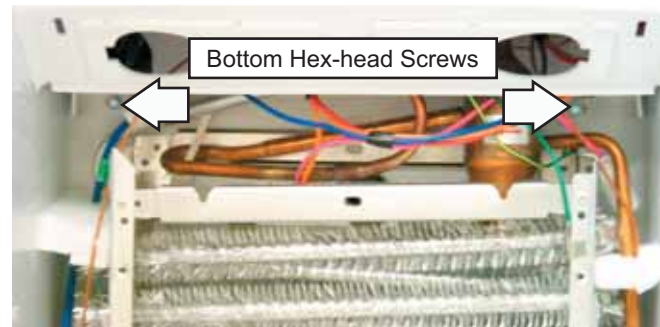
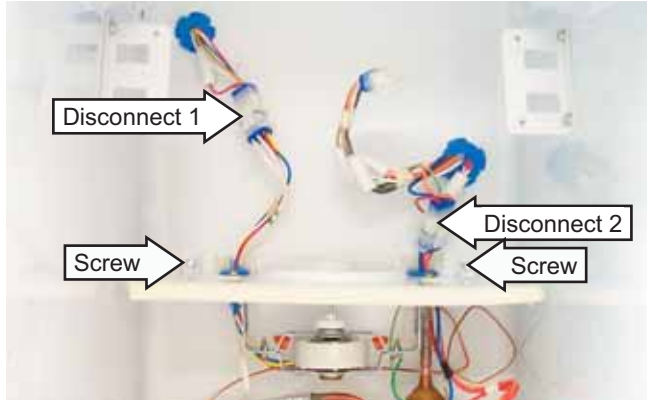

Fig. 2

11. Unclip the auger connector plug from the evaporator fan shroud. Slide the evaporator fan shroud down and out of the freezer compartment.



12. Disconnect the fan wiring harness (Disconnect 1). Disconnect the over temperature thermostat/light bulb wiring harness (Disconnect 2).
13. Remove the 2 hex-head screws that hold the fan bracket in place.



14. Remove the ground clip from the evaporator frame.
15. Unclip the evaporator thermistor.
16. Slide the over-temperature thermostat/light bulb wiring harness out of the fan bracket.
17. Remove the fan bracket.

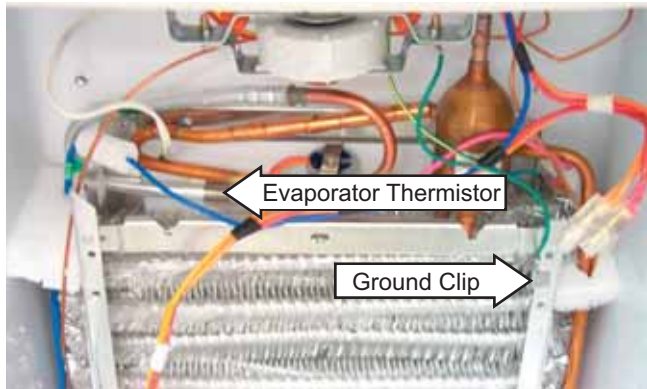

Note: When replacing the evaporator thermistor, cut the thermistor wires and splice the new thermistor using bell connectors. Always use RTV102 silicone to seal the end of the connector from moisture.

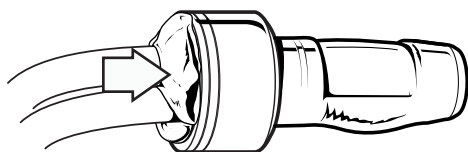

Replacing Freezer Evaporator Using the Brazing Method

Parts Needed:

- Freezer Evaporator (part # WR85X10061)
- Drier Assembly (part # WR86X93)
- Access Tube (part # WJ56X61)
- Heat Shield Kit (part # WX5X8926)

Caution: A heat shield kit is required for this procedure to prevent damage to the plastic interior (liner) of the freezer compartment.

Note: If it is determined that the epoxy joints (the transition joint between the aluminum and copper jumper) on the freezer evaporator assembly are defective, then LOKRING connectors can be used to repair the joints. Refer to Pub. No. 31-9067 for more LOKRING information.

1. Unplug the refrigerator.
2. Remove the rear access cover and evacuate the sealed system.
3. Remove components necessary to expose the evaporator. (See **Freezer Evaporator.**)
4. Remove the ice bucket, icemaker, auger assembly, fan motor housing, and fan motor.
5. Note the location of thermistor and thermostat on top of old evaporator and remove.
6. Remove heater from bottom of evaporator and discard. Bundle remaining wires and tape high on the back wall of freezer.
7. Apply a liberal amount of thermal paste to suction line where it enters the rear wall of freezer.
8. Insert the brazing shield behind the joint of the accumulator top and suction line to protect the liner.
9. Use torch to heat the joint of the accumulator top, separate the suction line and accumulator top and clean the suction line surface (Fig. 1 and 2).
10. Using the tubing cutter, cut fresh food evaporator jumper (right side) tube about 2 inches from the joint outlet end of the fresh food evaporator. Score and break the capillary tube about 2 inches from the end of freezer evaporator inlet jumper (left side) (Fig. 1 and 2).

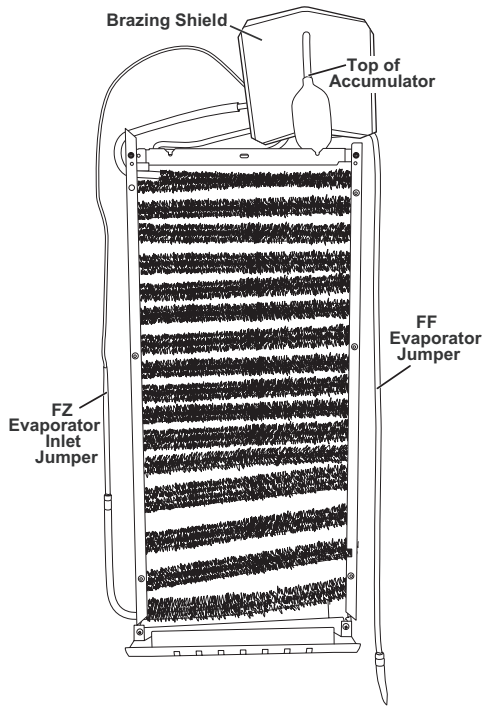

Fig. 1

- Loosen the hex-head screws that hold the evaporator in place. Note locations of the foam blocks at sides of old evaporator. These are needed for proper airflow. Remove the foam blocks and save for new evaporator installation. Remove old evaporator.

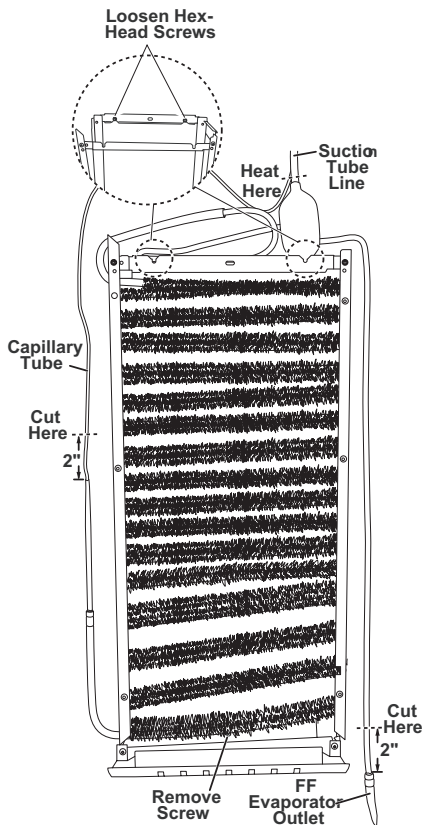
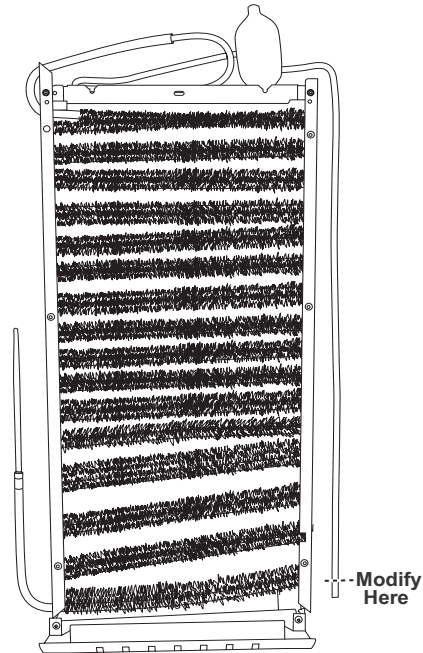

Fig. 2

- Modify replacement evaporator to accept the $\frac{5}{16}$ -in. fresh food evaporator jumper.



- Install the new evaporator and tighten all mounting screws.
- Connect tubes between top of accumulator and suction line. Connect tubes between fresh food evaporator and freezer evaporator (right side). Insert the capillary tube.
- Check that the thermal paste is still on the suction line where it enters the rear wall of the freezer. If not, apply paste. In addition, apply thermal paste around epoxy joints on the new evaporator to prevent the heat from damaging joint integrity.
- Protect the freezer floor from molten solder during brazing. Braze suction line to accumulator on new evaporator. Angle torch so that flame is directed away from rear wall when brazing.
- Move the brazing shield behind the capillary joint and braze the capillary tube.

18. Move the brazing shield behind the fresh food jumper to the freezer evaporator. Braze the jumper tube joint. Remove the brazing shield. Clean and inspect all joints.
19. Remove the old drier by cutting the halo loop as close as possible to the drier. Install the new drier assembly (part # WR86X93) making sure that there is sufficient space between the tubing.
20. Install the access tube. Clean and inspect joints.
21. Replace the heater supplied with the evaporator. Reinstall foam blocks, thermostat and thermistors. Dress wiring.
22. Evacuate and charge the system. Use original factory charge quantity of R-134a. (See **Evacuation and Charging Procedure.**)
23. Replace all component parts in the freezer.
24. Reinstall the rear access cover.

Replacing Freezer Evaporator Using the LOKRING Method

Parts Needed:

- Freezer Evaporator (part # WR85X10061)
- Drier Assembly (part # WR86X93)
- Access Tube (part # WJ56X61.)
- LOKRING Connectors (part # WR97X10021)

Note: If it is determined that the epoxy joints (the transition joint between the aluminum and copper jumper) on the freezer evaporator assembly are defective, then LOKRING connectors can be used to repair the joints. Refer to Pub. No. 31-9067 for more LOKRING information.

1. Follow steps 1 through 6 under **Replacing Freezer Evaporator Using the Brazing Method.**
2. Using the tubing cutter, cut the freezer evaporator jumper of the check-valve assembly (top) as close as possible to the joint of the copper jumper. Cut the jumper tube (left side) on the inlet of the freezer evaporator (capillary joint) as close as possible to the epoxy joint.

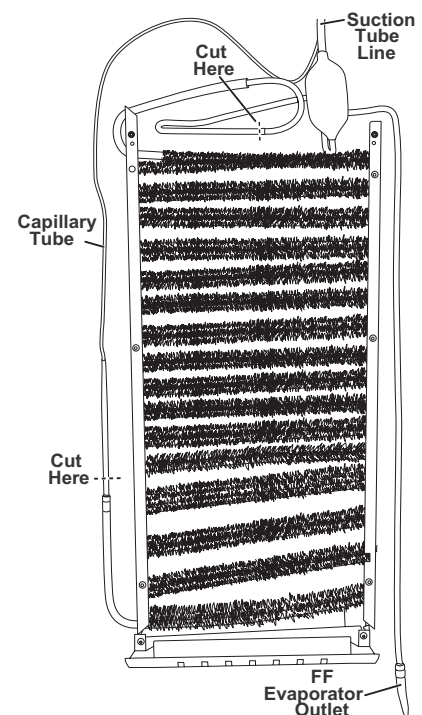

3. Loosen the hex-head screws that hold the evaporator in place. Note locations of the foam blocks at sides of old evaporator. These are needed for proper airflow. Remove the foam blocks and save for new evaporator installation. Remove old evaporator.

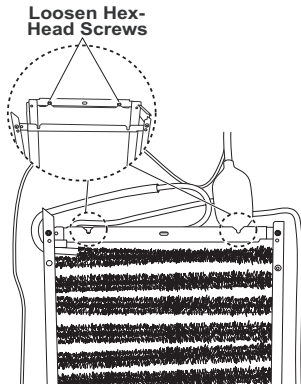

4. Modify replacement evaporator to use LOKRING connectors.
 - a. Using the tubing cutter, cut the jumper tube (top) at the outlet end of the freezer evaporator. Leave as much of the straight tube portion as possible from the joint of the check-valve assembly. Discard the check-valve assembly.
 - b. Using the tubing cutter, cut the jumper tube (left side) on the inlet end of the evaporator (capillary joint) about 3 inches from epoxy joint. Make two joints using the LOKRING connectors for $\frac{5}{16}$ -in. copper to copper joints.

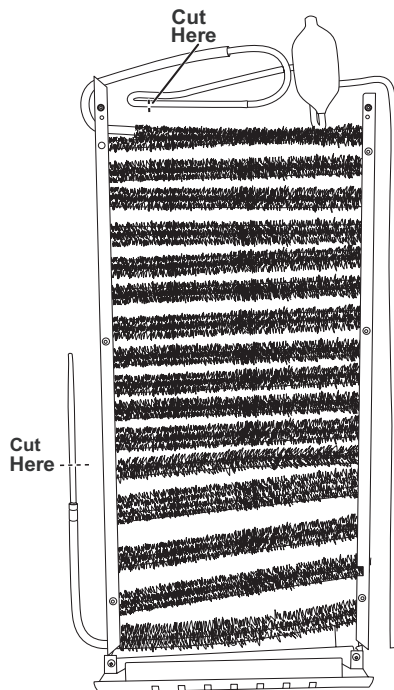

5. Install the new evaporator and tighten all mounting screws.
6. Remove the old drier by cutting the halo loop as close as possible to the drier. Install the new drier assembly (make sure there is sufficient space between the tubing).
7. Install the access tube. Clean and inspect joints.
8. Replace the heater supplied in the kit. Reinstall foam blocks, thermostat and thermistors. Dress the wiring.
9. Evacuate and charge the system. Use original factory charge quantity of R-134a. (See **Evacuation and Charging Procedure.**)
10. Replace all component parts in the freezer.
11. Reinstall the rear access cover.

Fresh Food Evaporator

1. Remove the custom cool drawer and necessary drawers and covers above the custom cool drawer, to expose the evaporator cover housing.
2. Remove the water line coil cover.

Note: The water line coil cover is slotted. To remove it, slide the water line coil cover toward the door opening.

3. Remove the 3 Philips-head screws that hold the fresh food evaporator fan cover in place.

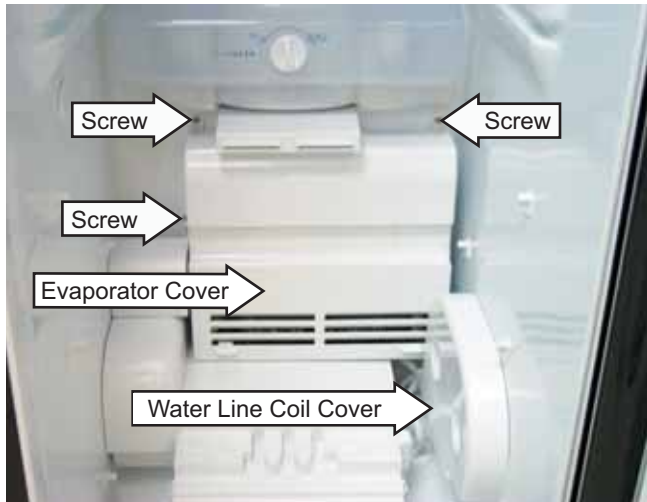

4. Carefully pull the cover forward, then disconnect the fresh food evaporator fan.

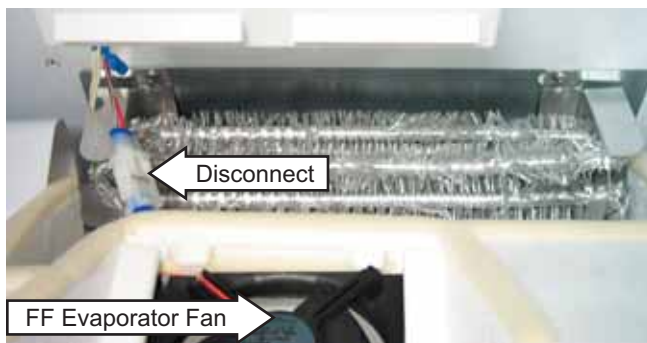

5. Loosen the 2 Phillips-head screws that hold the fresh food evaporator in place.

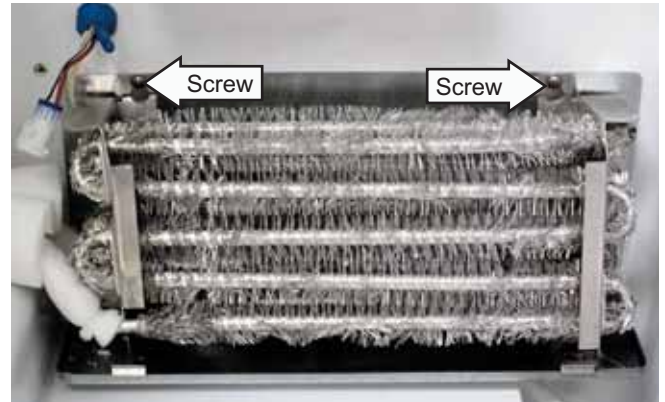

6. Carefully lift and pull the fresh food evaporator forward. Cut the tie strap that holds the thermistor block in place.
7. Remove the evaporator thermistor and block from the evaporator.

Replacing Fresh Food Evaporator Using the Brazing Method

Parts Needed:

- Fresh Food Evaporator (part # WR85X10060)
- Drier Assembly (part # WR86X93)
- Access Tube (part # WJ56X61)
- Heat Shield Kit (part # WX5X8926)

Caution: A heat shield kit is required for this procedure to prevent damage to the plastic interior (liner) of the freezer compartment.

Note: If it is determined that the epoxy joints (the transition joint between the aluminum and copper jumper) on the freezer evaporator assembly are defective, then LOKRING connectors can be used to repair the joints. Refer to Pub. No. 31-9067 for more LOKRING information.

1. Unplug the refrigerator.
2. Remove the rear access cover and evacuate the sealed system. (See *Evacuation and Charging Procedure*.)
3. Remove components necessary to expose both the freezer and fresh food evaporators. (See *Freezer Evaporator* and *Fresh Food Evaporator*.)
4. Remove the 2 foam tubes that are wire tied to the inlet and outlet tubes of the fresh food evaporator.
5. Remove the Styrofoam block that is inserted into the opening in the mullion wall and discard. A replacement is provided.
6. Loosen the 2 screws that attach the fresh food evaporator to the liner.

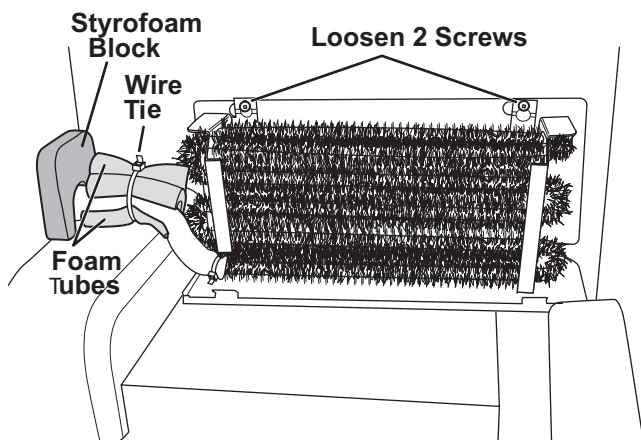

7. Pull the evaporator away from the liner and remove the thermistor from the aluminum block attached to the rear of the evaporator.
8. Look into the freezer compartment and locate the epoxy joints on the tubes leading to the fresh food evaporator. (These joints will be located on the right hand side of the freezer evaporator.)

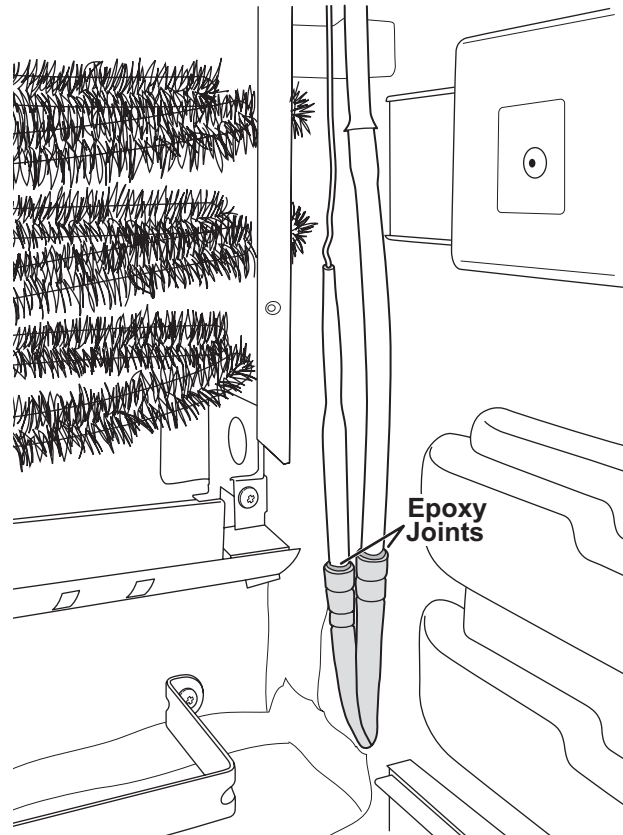

9. To allow easier access to the epoxy joints, pull them away from the side of the freezer evaporator into the freezer compartment.
10. Using the tube cutter, cut the $\frac{5}{16}$ -in. OD copper tube as close to the epoxy joint as possible. Score and break the capillary tube as close to the braze joint as possible.
11. Remove the fresh food evaporator.
12. Install new fresh food evaporator.

13. Connect the capillary tube to the inlet tube of the evaporator. Connect the $\frac{5}{16}$ -in. OD copper tube to the outlet tube of the evaporator (remove any excess length as required to obtain the correct fit).
14. Apply a liberal amount of thermal paste around both epoxy joints to prevent heat from damaging joint integrity.
15. Install a metal brazing shield between the joints and the plastic liner.
16. Protect the freezer floor from molten solder during brazing.
17. Angle torch so that the flame is directed away from the plastic liner. Braze both joints. Clean and inspect joints. Remove the brazing shield.
18. Clean thermal paste off the joints. Dress the joints to the right of the freezer evaporator so the freezer evaporator cover can be reinstalled without interference.
19. Reinsert the thermistor into the aluminum block on the rear of the new fresh food evaporator.
20. Attach the evaporator to the fresh food liner using the original screws. Ensure that the drain pan is properly positioned. Install a new Styrofoam block into the hole of the mullion. Attach foam tubes to evaporator inlet/outlet tubes using wire tie provided.
21. Remove the old drier by cutting the condenser loop as close as possible to the drier. Install the new drier assembly, making sure that there is sufficient space between the tubing. Install the access tube on the compressor.
22. Evacuate and charge the system. Use original factory charge quantity of R-134a. (See *Evacuation and Charging Procedure*.)
23. Replace all component parts in both the freezer and the fresh food compartments.
24. Reinstall the rear access cover.

Replacing Fresh Food Evaporator Using the LOKRING Method

Parts Needed:

- Drier Assembly (part # WR86X93)
- Process Tube (part # WJ56X61)
- LOKRING Connectors (part # WR97X10021)

Note: If it is determined that the epoxy joints (transition joint between the aluminum and copper jumper) on the freezer evaporator assembly are defective, then LOKRING connectors can be used to repair the joints. Refer to Pub. No. 31-9067 for more LOKRING information.

1. Follow steps 1 through 9 under *Replacing Fresh Food Evaporator Using the Brazing Method*.
2. Using the tube cutter, cut both copper tubes as close to the epoxy joint as possible. Leave as much $\frac{5}{16}$ -in. tubing as possible for a good LOKRING connection.
3. Remove the fresh food evaporator.
4. Modify replacement evaporator to use LOKRING connectors.
 - a. Using the tubing cutter, cut the jumper tube at the outlet end of the evaporator 2 inches from the epoxy joint.
 - b. Cut the jumper tube on the inlet end of the evaporator (capillary joint) $1\frac{1}{2}$ inches from the epoxy joint. Make two joints using the LOKRING connectors for $\frac{5}{16}$ -in. copper to copper joints.

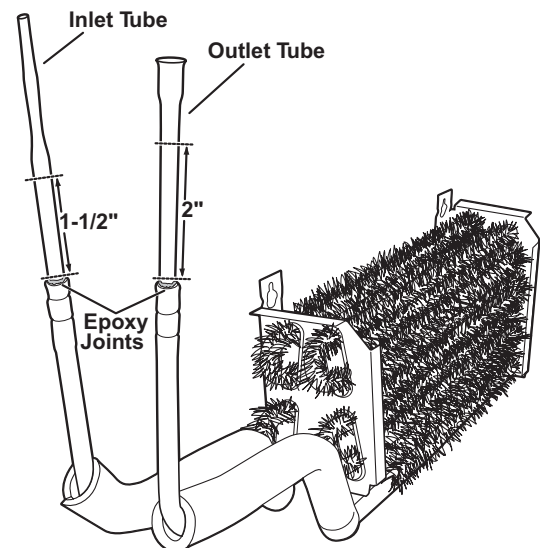

5. Reinsert the thermistor into the aluminum block on the rear of the new fresh food evaporator.
6. Attach the evaporator to the fresh food liner using the original screws. Ensure that drain pan is properly positioned. Install a new Styrofoam block into the hole of the mullion. Attach foam tubes to the evaporator inlet/outlet tubes using wire tie provided.
7. Remove the old drier by cutting the condenser loop as close as possible to the drier. Install the new drier assembly (make sure there is sufficient space between the tubing). Install the process tube on the compressor.
8. Evacuate and charge the system. Use original factory charge quantity of R-134a. (See **Evacuation and Charging Procedure.**)
9. Replace all component parts in both the freezer and the fresh food compartments.
10. Reinstall the rear access cover.

Accumulator

- The accumulator collects any liquid refrigerant left in the evaporator before it enters the suction line.
- The liquid refrigerant pools in the bottom of the accumulator until it is drawn into the compressor as a vapor.
- The accumulator comes as a part of the freezer evaporator. It is not available separately.



Check Valve

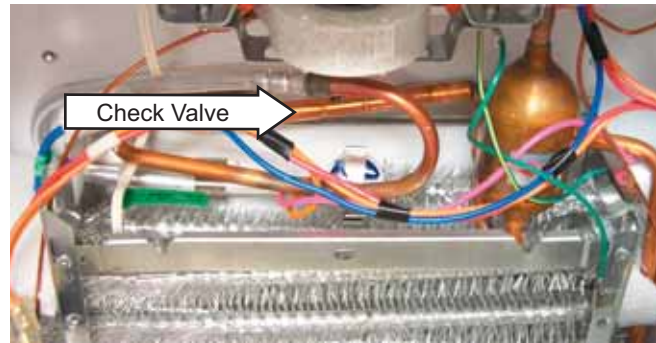

- A nylon piston inside the check valve floats back and forth, depending upon refrigerant flow.
- The check valve prevents refrigerant from flowing back into the freezer evaporator.
- When the main control rotates the 3-way valve for fresh food only cooling, the check valve will prevent refrigerant from flowing in the freezer evaporator (refrigerant will naturally flow to the coldest area).
- The check valve is only available with a new freezer evaporator.

Caution: Do not attempt to replace only the check valve. The nylon piston in the check valve is extremely heat sensitive.

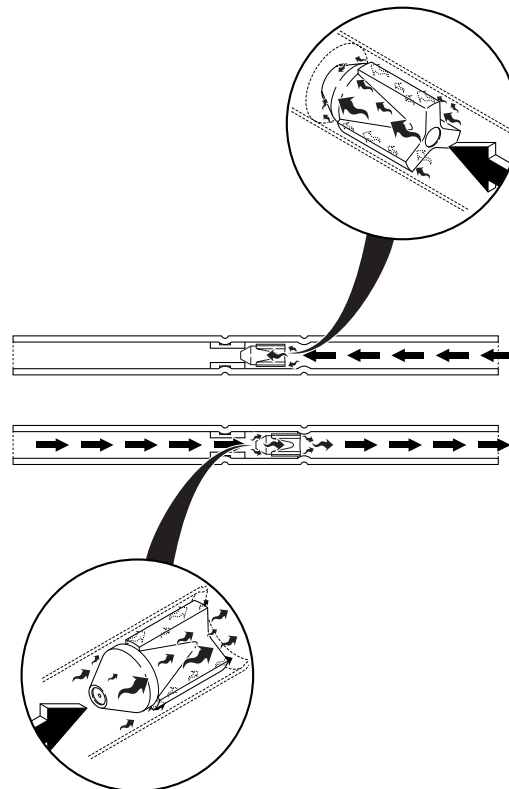

Troubleshooting

Control Diagnostics

Enter the diagnostic mode by pressing both the freezer temperature (COLDER and WARMER) pads and the refrigerator temperature (COLDER and WARMER) pads simultaneously. All four pads must be held for approximately 3 seconds. Blinking "0"s in both displays indicate the refrigerator has entered the test mode.

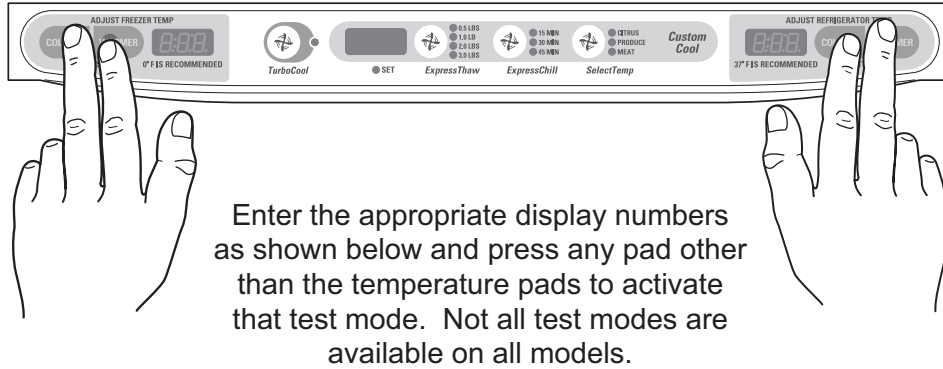

Freezer Display	Fresh Food Display	Diagnostics	Results	Comments
0	2	Communication check between Temperature Control and Main Control	"P" on freezer display if OK. "F" if problem is found.	
0	4	Communication check between Dispenser Control and Main Control	"P" on freezer display if OK. "F" if problem is found.	
0	6	Temperature Control LED Test	All LEDs light. Pressing the corresponding pad turns off the LED.	See Note 3.
0	7	Control and Sensor System Test	Checks each thermistor and displays "P" for pass and "0" for fail.	See Note 1.
0	8	Duct Door Test	Opens the dispenser duct door for 10 seconds, then closes.	Test can be performed with door open.

Freezer Display	Fresh Food Display	Diagnostics	Results	Comments
1	0	Dampers Test	Double damper will open, close after 10 seconds, pause briefly, then single damper will open for 10 seconds.	Test will not start for 20 seconds after pad is depressed.
1	1	Fan Test	Cycles through each fan for 5 seconds.	
1	2	100% Run Time	Sealed system on 100% of the time. Times out after 1 hour.	
1	3	Prechill Test	Starts Prechill mode. Unit returns to normal on its own.	
1	4	Defrost Test	Toggles on the defrost cycle. See Note 2.	Must press again to turn heaters off. See Note 2.
1	5	Main Control Reset	Causes a system reset.	
1	6	Exit Diagnostics Mode	Causes a temperature control board reset.	

Note 1: Display order is #1 = Fresh Food Evaporator Thermistor, #2 = Fresh Food Thermistor, #3 = Custom Cool Thermistor, #4 = Freezer Evaporator Thermistor, #5 = Freezer Thermistor.

Thermistor test results are: P = Pass, 0 = Fail, S = Short to 5 VDC, B = Bad amplifier (replace main control).

Note 2: You **must** enter the defrost test again to toggle the defrost heater off at the end of the test. The heater will not come on if the evaporator thermistor is above 70°F.

Note 3: To exit the Temperature Control LED Test, press both refrigerator temperature pads (COLDER and WARMER) simultaneously for 3 seconds.

Illustrated Parts

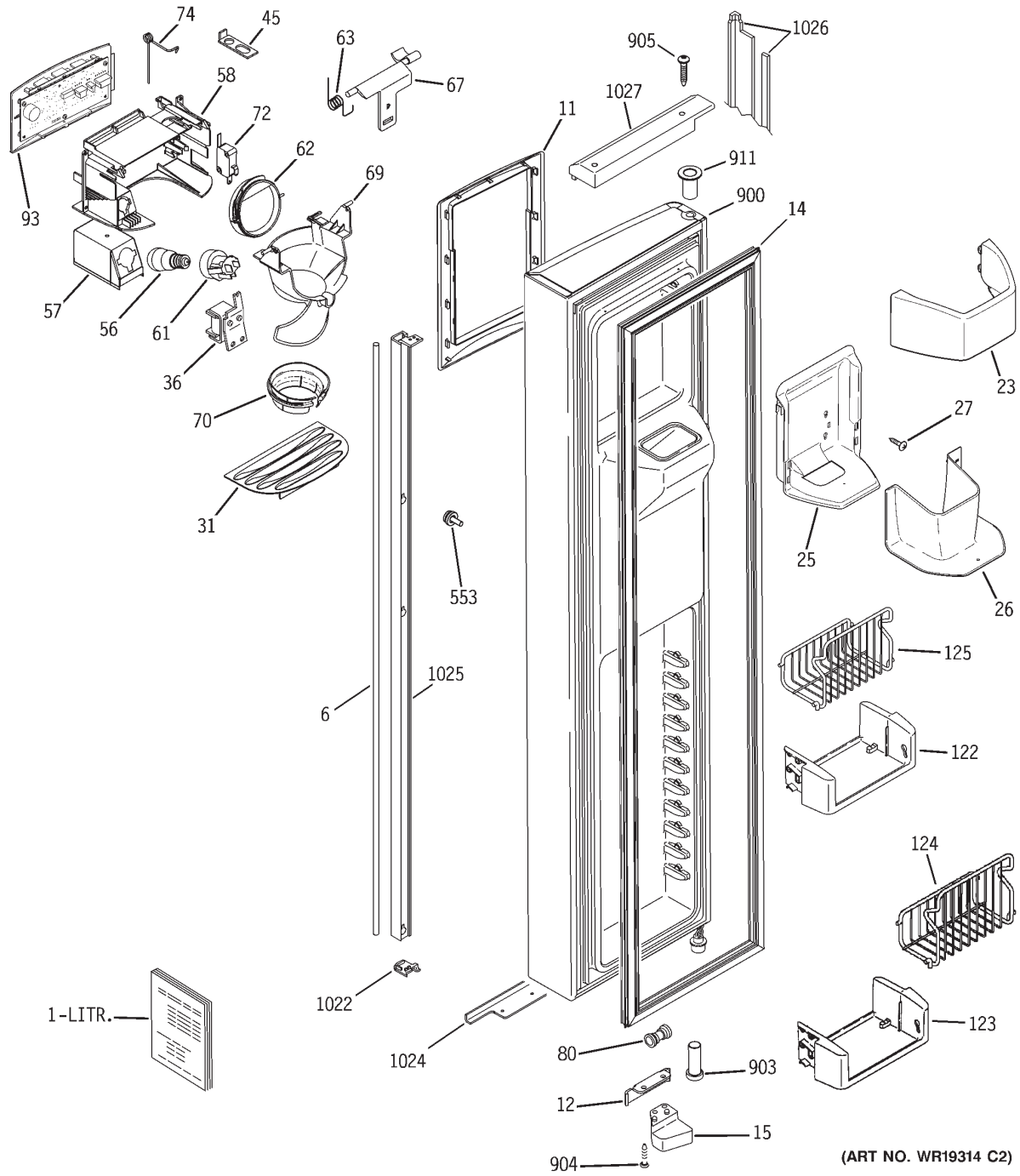

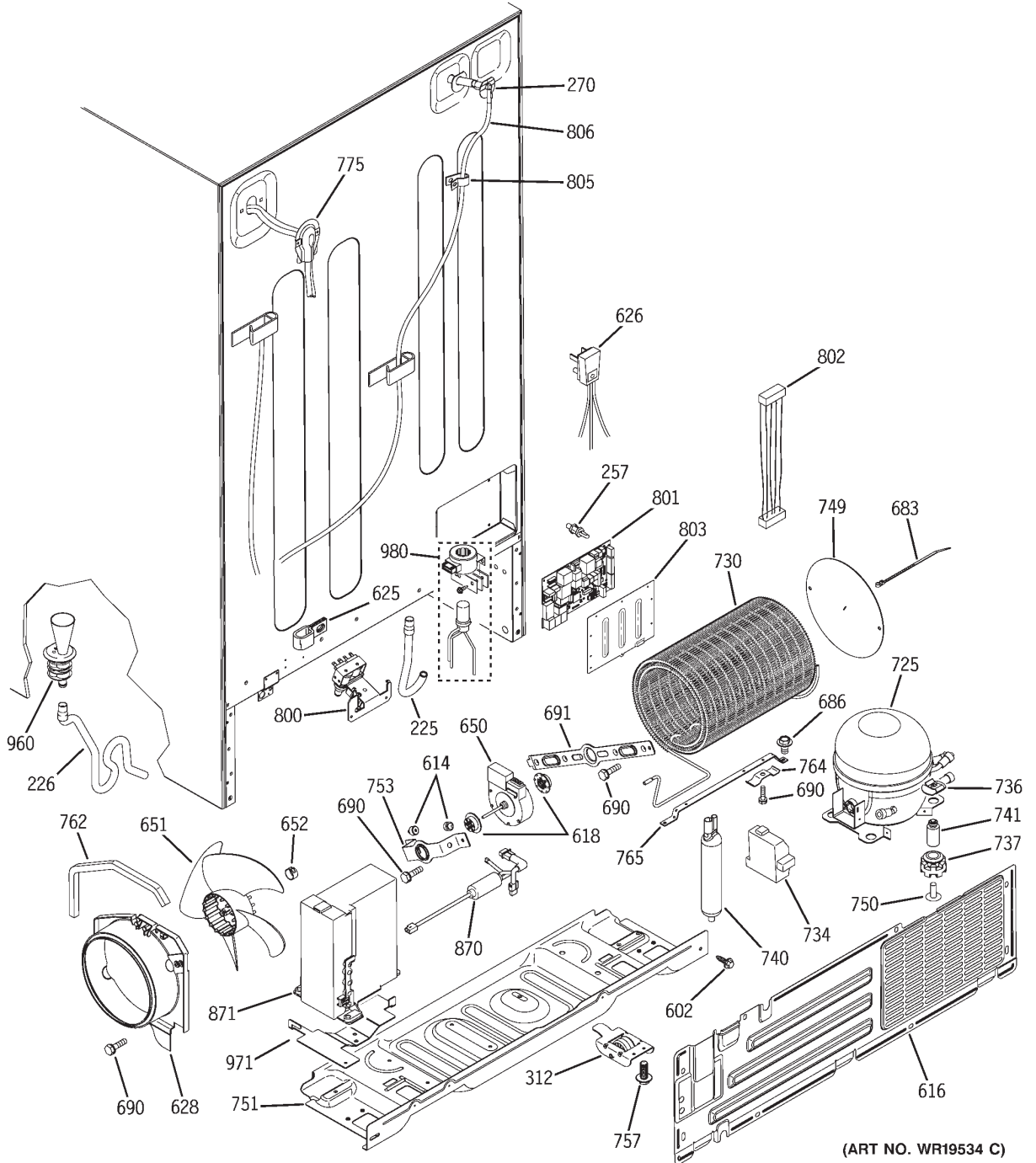

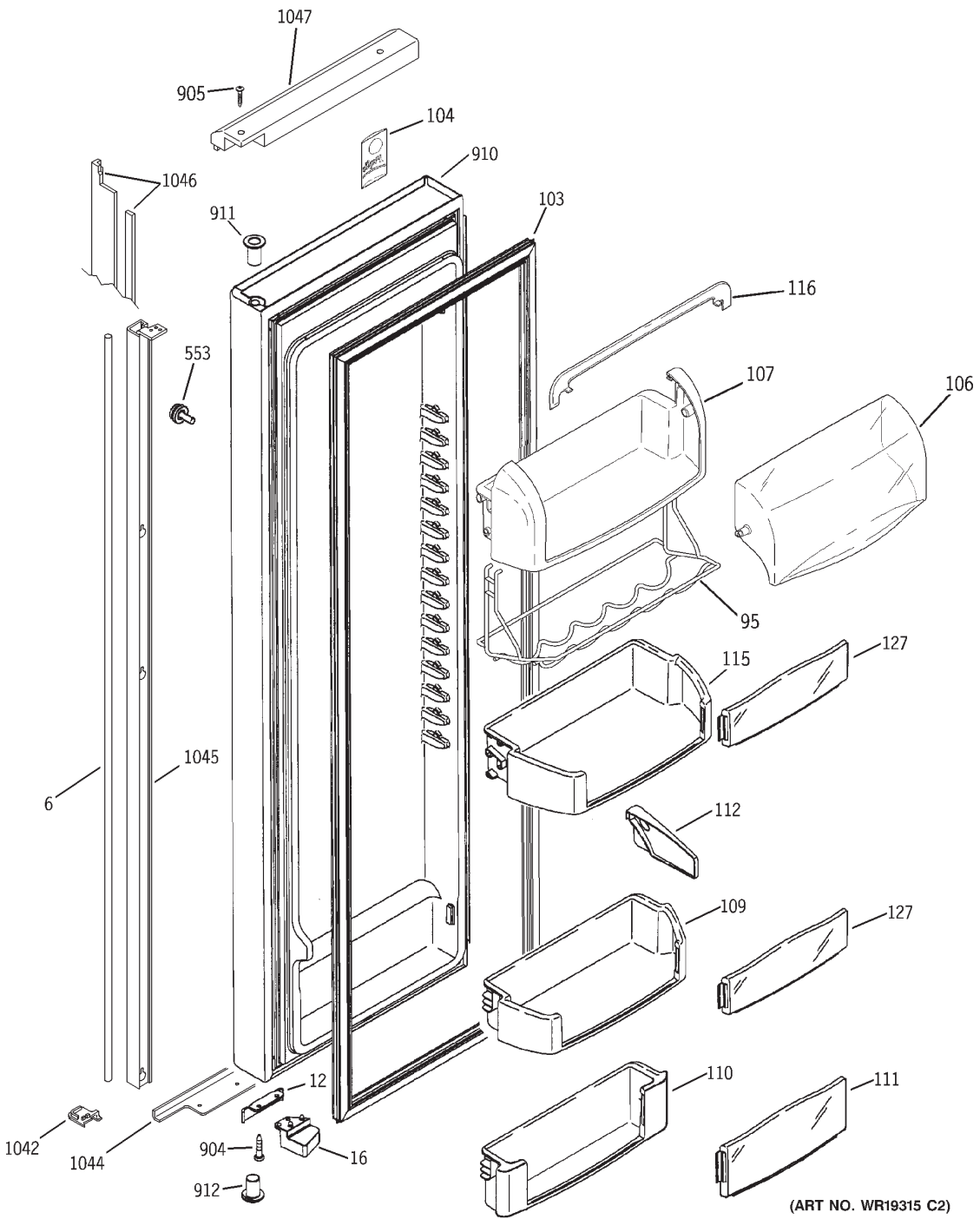

IMPORTANT NOTE:

Additional parts are required to install evaporator. See EVAPORATOR INSTRUCTIONS page of this model for additional part numbers and replacement options

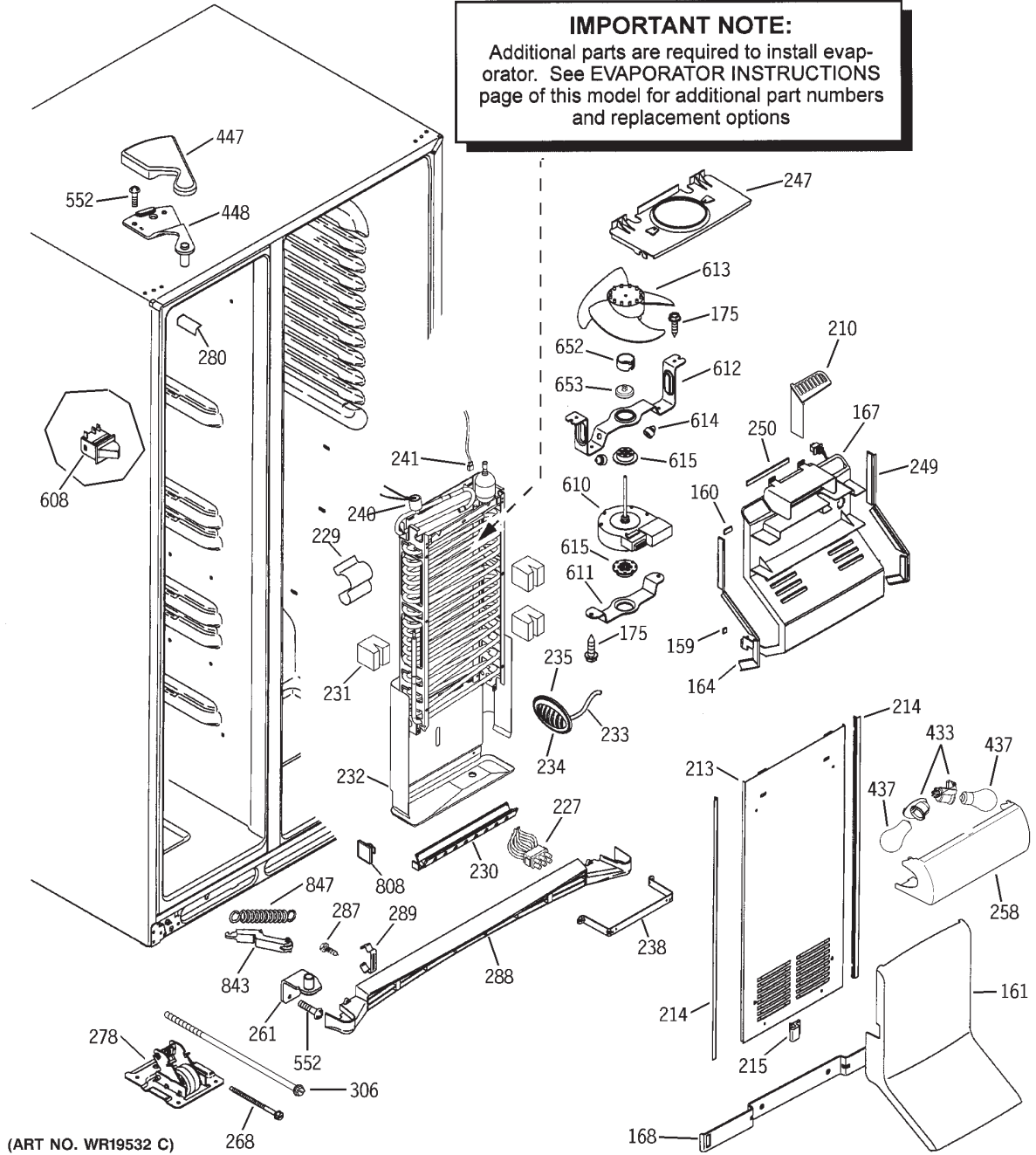

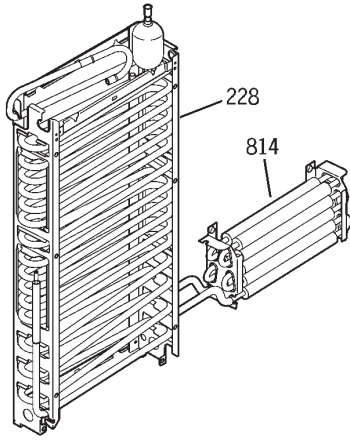

EVAPORATOR INSTRUCTIONS

There are two approved evaporator replacement methods. The LOKRING® method requires no brazing, by utilizing tight mechanical connections. The heat shield uses the traditional brazing method, but provides protection to the liner while brazing the evaporator connections in the freezer compartment.

Always add a new drier (WR86X93) when servicing the sealed system. Follow each step of the instructions included with the replacement evaporator.

LOKRING® METHOD

LOKRING® is a method of installing the evaporator without the use of a torch. It utilizes a mechanical connection rather than a brazed connection. Apply a few drops of LokPrep (a special cleaning and sealing solution), to the ends of the tubing that you wish to join together. The LOKRING® tool compresses the connector to ensure a tight mechanical connection. The parts shown to the right are required for the LOKRING® replacement method.

For additional information on how to use LOKRING®, call 1-800-848-7722 & order publication # 31-9067 (LOKRING® repair procedures manual) and publication # 31-9066 (LOKRING® repair procedures VHS video tape).

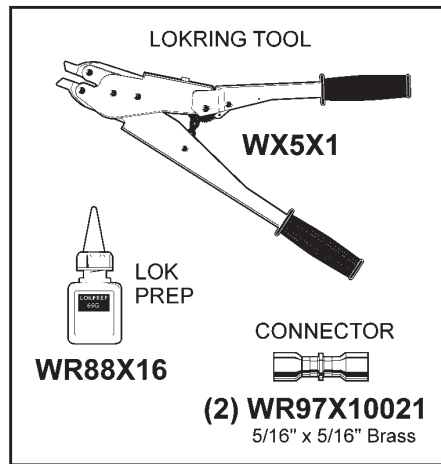

HEAT SHIELD METHOD

The heat shield kit is used to prevent damage to the refrigerator liner when brazing the evaporator into the sealed system. The kit comes with enough heat absorbing paste to complete four repairs. For additional heat absorbing paste, order WX5X8927.

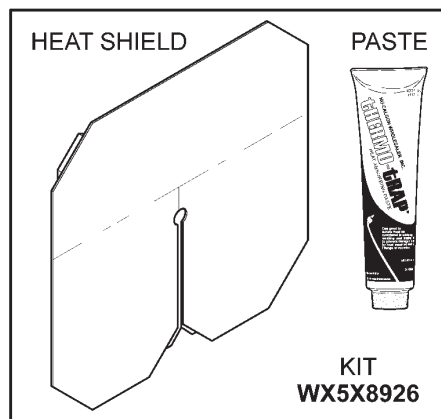

(ART NO. WR19542 C)

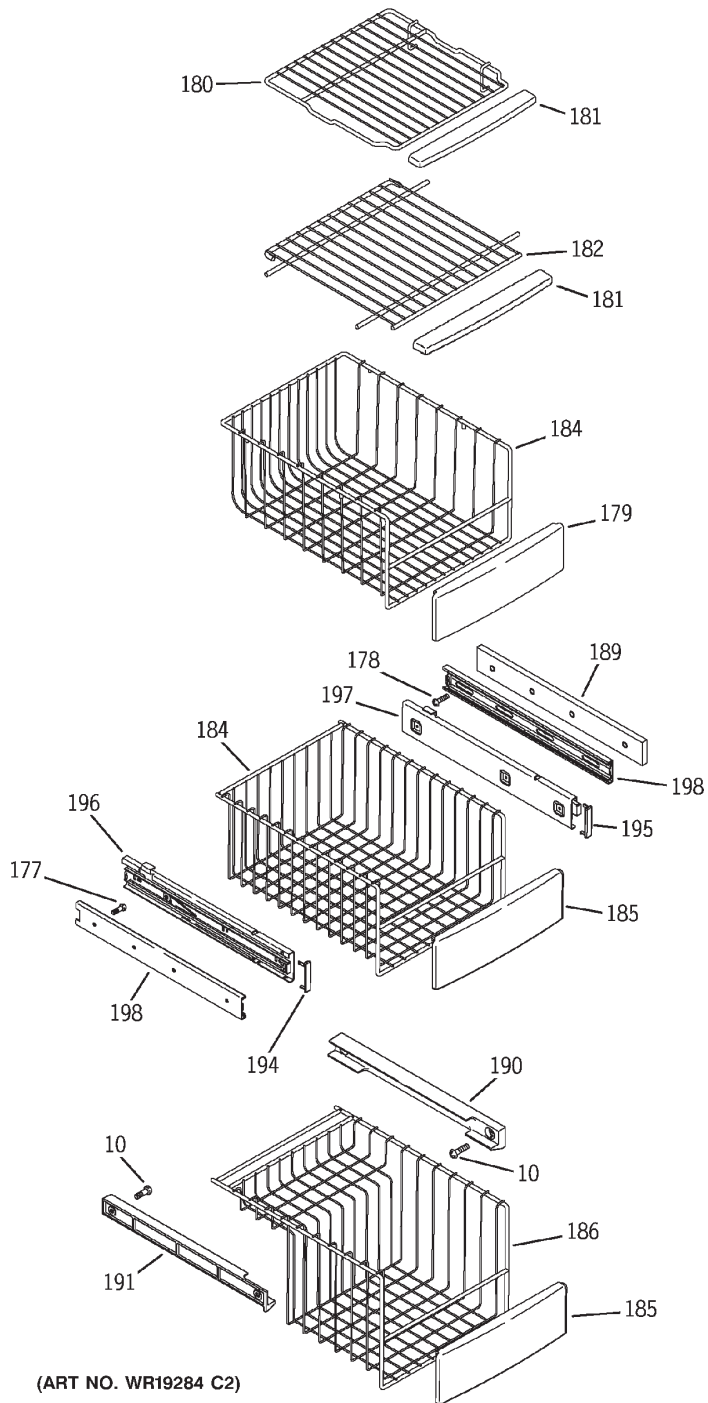

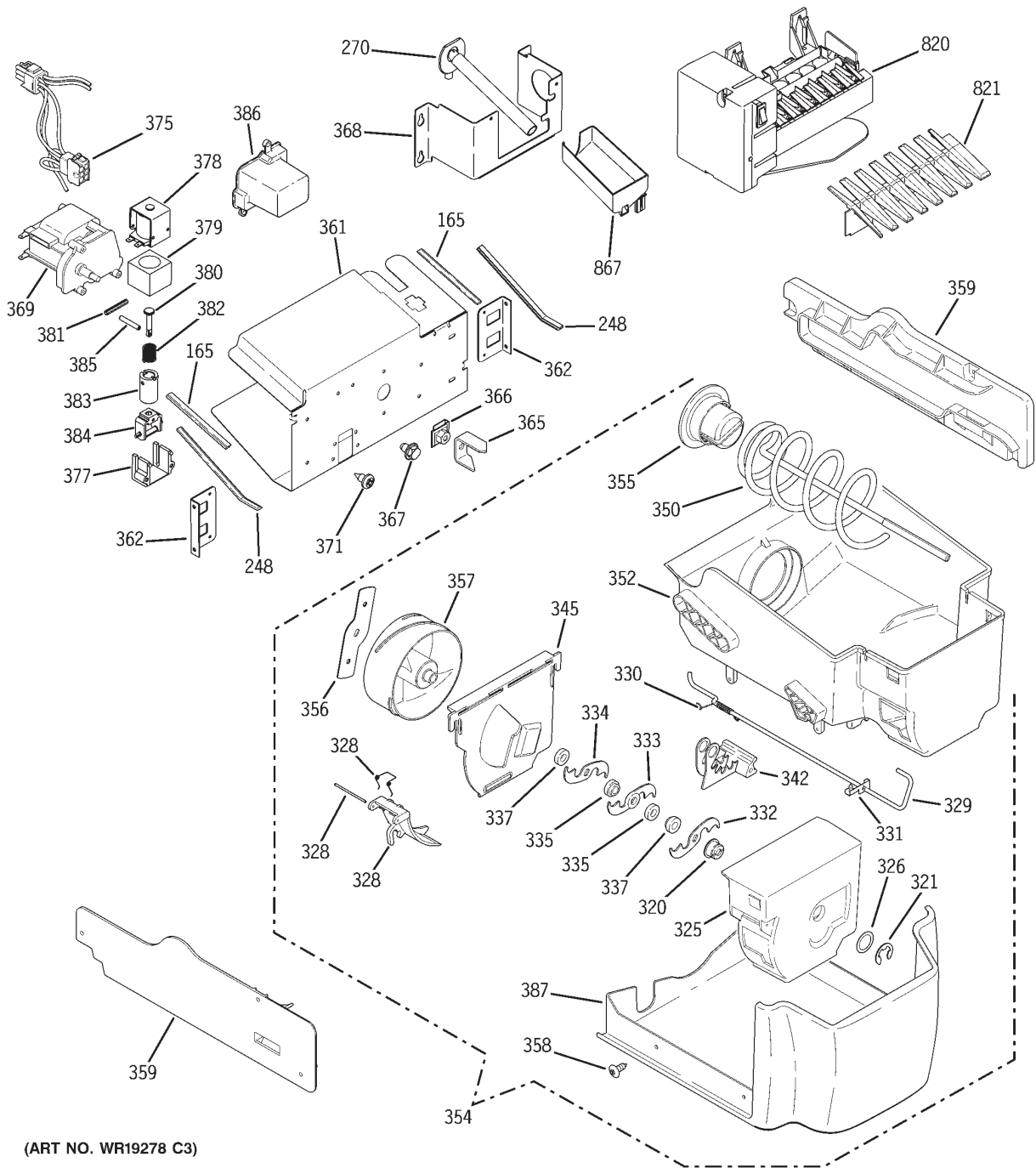

(ART NO. WR19278 C3)

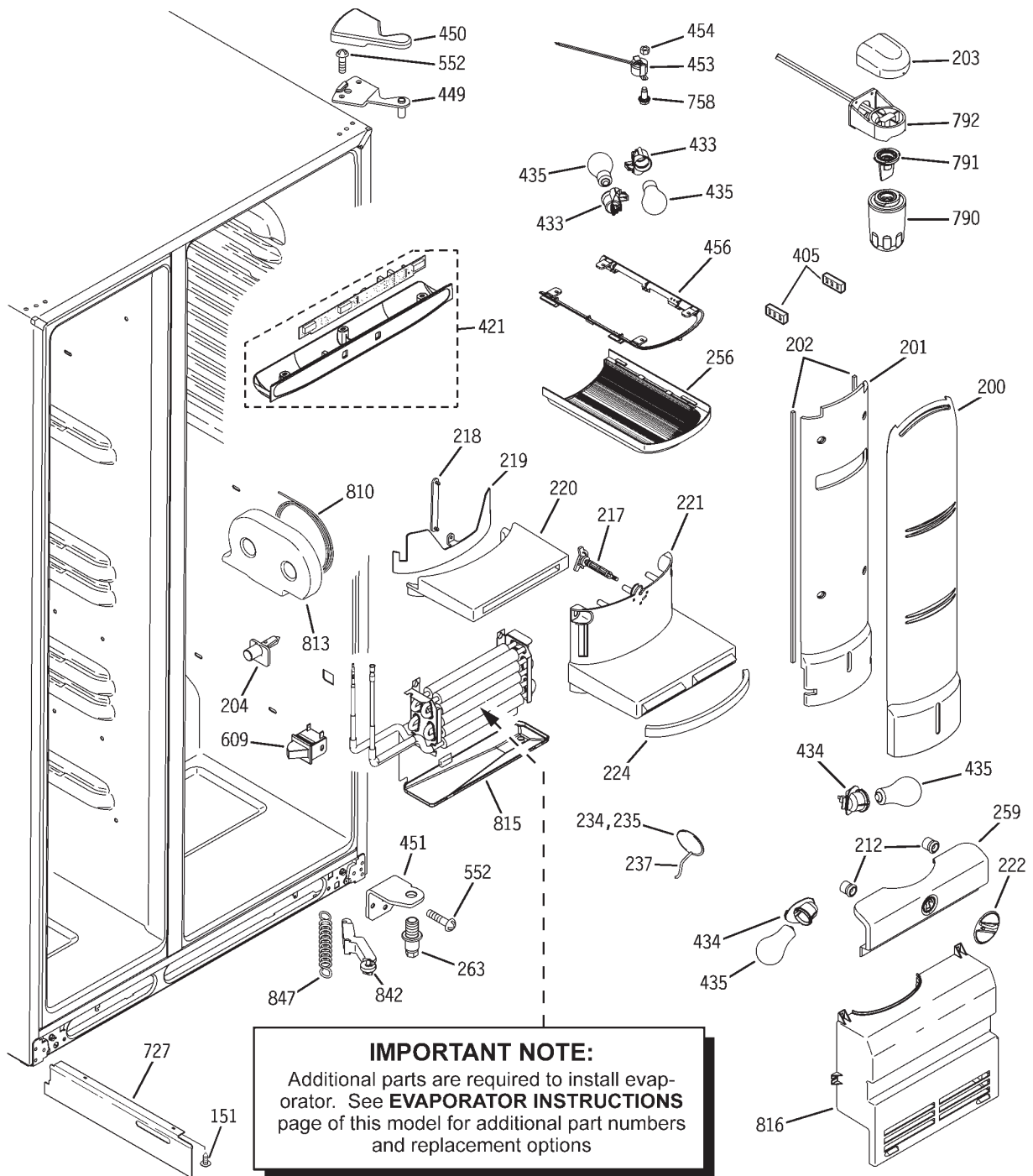

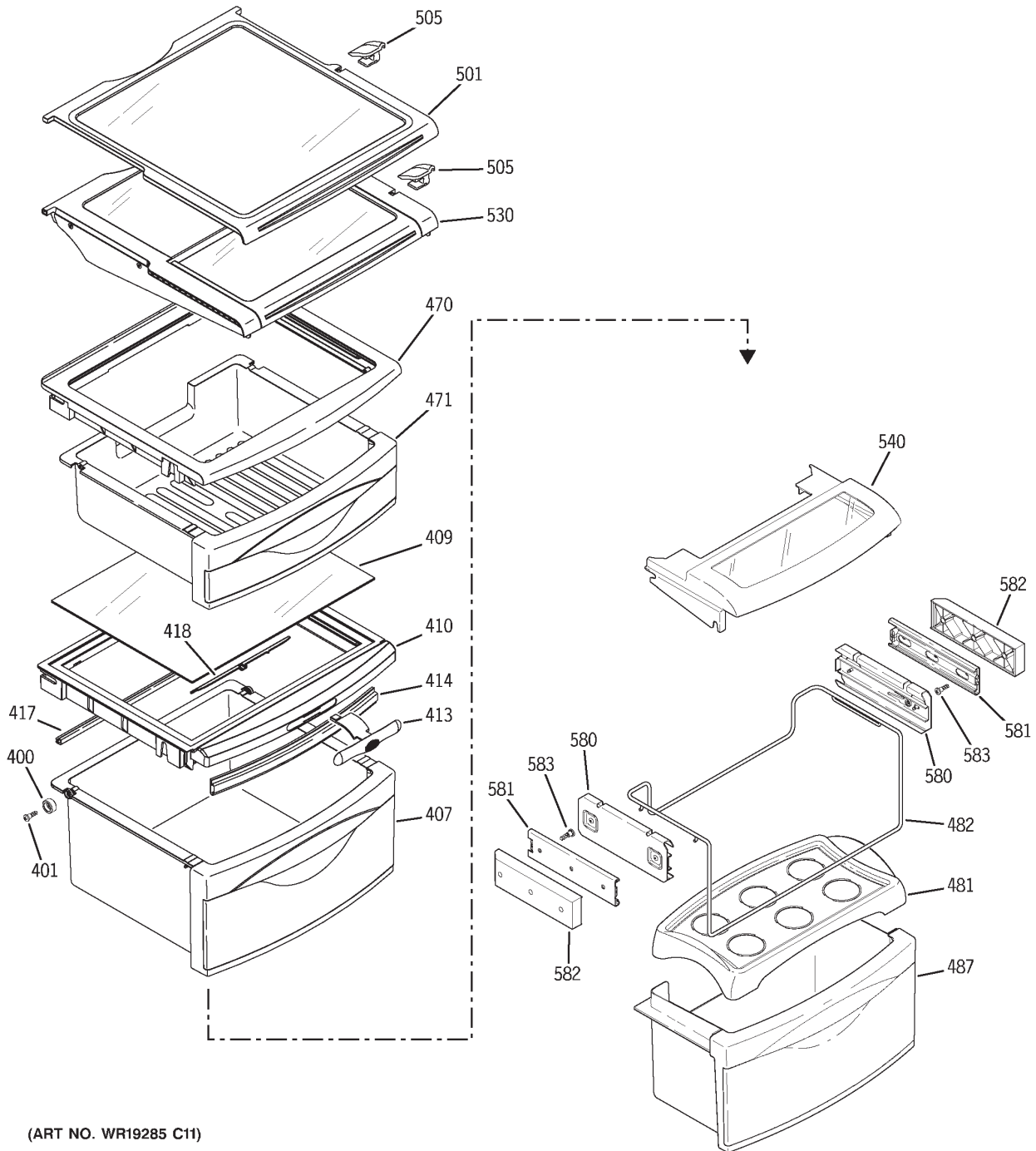

(ART NO. WR19285 C11)

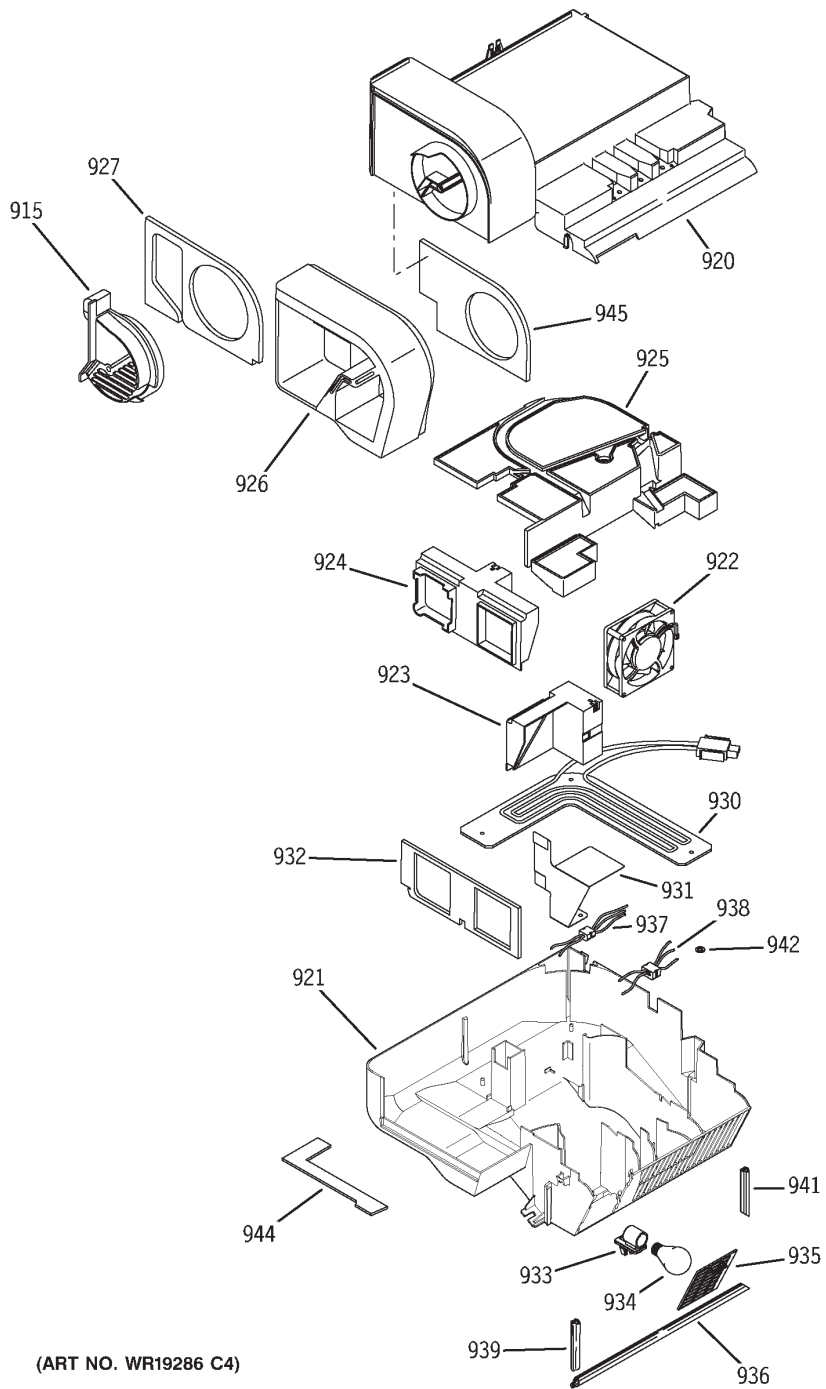

(ART NO. WR19286 C4)

VIEW NUMBER	CATALOG NUMBER	DESCRIPTION	QUANTITY
0001	31-51518	PM MINI WIRING MANUAL	1
0001	49-60238	PM GUIDE OWNERS	1
0006	WR12X10561	HANDLE SOFT TOUCH INSERT	2
0010	WR01X10065	SCR 8-18 BA POR 5/8 SS	15
0011	WR38X10245	TRIM RECESS WH	1
0012	WR02X10649	STOP DOOR WH	2
0014	WR24X10156	GASKET DOOR FZ WH	1
0015	WR02X10638	CAM CLOSURE FZ WH	1
0016	WR02X10637	CAM CLOSURE FF WH	1
0023	WR71X10499	MODULE FZ UPPER	1
0025	WR71X10500	MODULE FZ SEAT	1
0026	WR71X10495	GUIDE ICE	1
0027	WR01X10387	SCR 8-18 AB OVP 7/8 SS	2
0031	WR17X11654	GRILLE RECESS WH	1
0036	WR62X10020	SOLENOID ASM	1
0045	WR02X8818	RETAINER RECESS DOOR	2
0056	WR02X10675	BULB RECS 12V	1
0058	WR17X11081	HOUSING SHIELD DISP WH	1
0061	WR02X9561	LAMP SOCKET	1
0062	WR17X11653	DOOR RECESS ASM	1
0063	WR02X10585	SPRING RECESS DOOR	1
0067	WR17X10706	CRANK DOOR RECESS	1
0069	WR17X11264	FUNNEL ICE DISP WH	1
0070	WR17X11265	EXTENSION FUNNEL ICE WH	1
0070	WR49X10075	EXTENSION FUNNEL ICE WH	1
0072	WR23X10224	SWITCH	1
0074	WR02X10584	SPRING FUNNEL	1
0080	WR02X11330	UNION CONNECTOR	1
0093	WR55X10469	INTERFACE DISP ASM	1
0095	WR17X11481	WINE & BEVERAGE RACK	1
0103	WR24X10155	GASKET DOOR FF WH	1
0104	WR04X10129	LENS NAMEPLATE	1
0106	WR22X10042	DOOR DAIRY CLEAR	1
0107	WR22X10041	COMPARTMENT DAIRY	1
0109	WR71X10594	MODULE SHELF FF	1
0110	WR71X10297	MODULE SHELF FIXED FF	1
0111	WR71X10298	INSERT MODULE FF FIXED	1
0112	WR02X10639	SNUGGER	2
0115	WR71X10253	MODULE SHELF FF	2
0116	WR22X10043	TRIM DAIRY COMPARTMENT	1
0122	WR71X10256	MODULE SUPPORT FZ	2

VIEW NUMBER	CATALOG NUMBER	DESCRIPTION	QUANTITY
0123	WR71X10255	MODULE SUPPORT FZ	1
0124	WR21X10053	BASKET WIRE TILTOUT FZ	1
0125	WR21X10054	BASKET WIRE TILTOUT FZ	2
0127	WR71X10380	MODULE SHELF INSERT	3
0151	WR01X1554	SCR 8-18 AB IHXW 1/2 S	14
0159	WR14X10067	FOAM STRIP SE ADH	1
0160	WR14X10068	FOAM STRIP SE ADH	1
0161	WR17X11257	DUCT EXTENSION FZ ASM	1
0164	WR14X10164	GASKET PLENUM	1
0165	WR14X10167	GASKET MOTOR COVER	2
0167	WR17X11477	PLENUM FAN EVAPORATOR	1
0168	WR02X10674	BRACKET FZ TOWER LOWER	1
0175	WR01X10035	SCR 8-18 AB IHW 5/8 S	23
0177	WR01X10240	8-8X7/16 TORX PAN HEAD	9
0178	WR01X10241	8-18X13/16 TROX PAN HEAD	9
0179	WR12X10624	HANDLE	1
0180	WR71X10527	SHELF FIXED FZ	1
0181	WR38X10214	TRIM SHELF FZ	2
0182	WR71X10498	SHELF ADJUSTABLE FZ	1
0184	WR21X10040	BASKET FZ LONG	3
0185	WR12X10625	HANDLE	3
0186	WR21X10041	BASKET WIRE FZ SHORT	1
0189	WR17X10945	SPACER	3
0190	WR72X10066	SUPPORT SLIDE BASKET RH	1
0191	WR72X10067	SUPPORT SLIDE BASKET LH	1
0194	WR02X10810	COVER L.H.	3
0195	WR02X10811	COVER R.H.	3
0196	WR72X10068	SLIDE & BRACKET ASM LH	3
0197	WR72X10069	SLIDE & BRACKET ASM RH	3
0198	WR72X10070	SLIDE LINER	6
0200	WR17X11702	COVER FF AIR TOWER	1
0201	WR17X11703	EPS FF TOWER	1
0200	WR17X11805	COVER FF AIR TOWER	1
0202	WR14X10188	GASKET TOWER FF	2
0203	WR17X11711	COVER WATER FILTER	1
0204	WR02X10676	FRAME SUPPORT PINS	6
0202	WR17X11805	GASKET TOWER FF	2
0208	WR01X10431	NUT 6-32 UN	1
0210	WR74X10131	GUARD WIRING	1
0212	WR02X10689	GROMMET BASE GRILLE	2
0213	WR17X11803	COVER EVAPORATOR FRONT	1
0214	WR14X10153	GASKET EVAP COVER	2

VIEW NUMBER	CATALOG NUMBER	DESCRIPTION	QUANTITY
0210	WR74X10131	GUARD WIRING	1
0215	WR01X10211	BRACKET FZ TOWER UPPER	2
0217	WR32X10154	DIAL PAN CHILL	1
0218	WR02X10665	LINKAGE PAN CHILL	1
0219	WR02X10664	SHUTTER PAN CHILL	1
0220	WR02X11851	EPS PAN CHILL	1
0221	WR02X11852	DISCHARGE PAN CHILL	1
0222	WR02X10666	KNOB PAN CHILL	1
0224	WR02X11853	FOAM STRIP SE ADH	1
0225	WR02X11426	TUBE DRAIN	1
0226	WR02X11848	TUBE DRAIN	1
0227	WR23X10337	HARNES AC FZ INTERMEDIA	1
0228	WR85X10061	LOW SIDE ASM FZ	1
0229	WR02X10552	CLIP EVAP THERMISTOR	1
0230	WR51X10042	HEATER & BRACKET ASM	1
0231	WR02X10669	BLOCK EVAP SEAL	3
0232	WR17X10811	SHIELD ASM TROUGH	1
0233	WR55X10026	SENSOR TEMP FZ	1
0234	WR02X10647	GRILLE SENSOR	2
0235	WR02X10668	SHUNT SENSOR	2
0237	WR55X10028	SENSOR TEMP FF	1
0240	WR50X10028	DEFROST THERMOSTAT	1
0233	WR55X10025	SENSOR TEMP FZ	1
0241	WR55X10025	SENSOR TEMP FF	1
0247	WR17X10812	ORIFICE FAN ASM	1
0248	WR14X10168	GASKET MOTOR COVER	2
0237	WR55X10025	SENSOR TEMP FF	1
0249	WR14X10165	GASKET PLENUM	1
0250	WR14X10069	FOAM STRIP SE ADH	1
0256	WR17X11713	SHIELD LIGHT FF	1
0257	WR02X10663	STAND OFF	4
0258	WR17X11480	SHIELD LIGHT FZ	1
0259	WR17X11712	LIGHT SHIELD	1
0261	WR13X10137	HINGE BTM & PIN ASM WH	1
0263	WR02X10648	PIN HINGE BTM ADJ HOLLOW	1
0268	WR01X10210	SCREW MOBILITY 3.5	2
0270	WR17X11506	GROMMET AND TUBE ASM	1
0278	WR02X10636	MOBILITY FRONT ASM	2
0280	WR02X10640	CAP CORNER OC WH	2
0288	WR74X10071	GRILL BASE ASM AWH	1
0306	WR02X10833	SCREW MOBILITY 23	2

VIEW NUMBER	CATALOG NUMBER	DESCRIPTION	QUANTITY
0312	WR02X10827	MOBILITY ASSY BACK-BIS	2
0320	WR01X10315	NUT AUGER FRT DISP	1
0321	WR01X1367	RETAINER RING E	1
0325	WR17X10717	HOUSING CRUSHER DISP	1
0326	WR01X1366	WASHER	1
0328	WR02X4143	PIN DEFLECTOR DISP	1
0328	WR02X4561	SPRING ICE DEFLECTOR	1
0328	WR17X10703	DEFLECTOR ICE DISP	1
0329	WR17X11486	WIRE ACTUATOR DISP	1
0321	WR1X1367D	RETAINER RING E	1
0330	WR02X10583	SPRING DEFLECTOR	1
0325	WR17X11505	HOUSING CRUSHER DISP	1
0331	WR02X10580	RETAINER SPRING	1
0326	WR1X1366D	WASHER	1
0332	WR17X1361	BLADES MOVING DISP	1
0333	WR17X1362	BLADES MOVING DISP	1
0334	WR17X1363	BLADES MOVING DISP	1
0335	WR02X4139	SPACER CRUSHER MIDDLE	3
0337	WR02X4138	SPACER CRUSHER STATIONAR	2
0342	WR02X10691	STATIONARY BLADES ASM	1
0345	WR17X11453	COVER CRUSHER	1
0350	WR17X11479	AUGER HELIX DISP	1
0352	WR30X10046	BUCKET ICE DISP	1
0354	WR17X11483	BUCKET AND AUGER ASM	1
0355	WR17X11459	CUP DRIVE	1
0356	WR17X11458	PLATE HELIX LOCK	1
0357	WR17X11457	HELIX	1
0358	WR01X10389	SCR 8-18 AB PHR 1/2 S	6
0359	WR72X10138	GLIDE BUCKET RH	1
0359	WR72X10139	GLIDE BUCKET LH	1
0361	WR17X11460	COVER MTR & SOLENOID	1
0362	WR02X10656	BRACKET ANGLE	2
0365	WR02X11534	DRIVE AUGER DISP	1
0366	WR01X10190	NUT J	1
0367	WR01X10198	SCR 8-18 TPT 1/4	5
0368	WR02X11336	BRACKET IM MOUNTING	1
0369	WR60X10125	MOTOR CRUSHER DISP	1
0371	WR01X10192	SCR 10-18 HI/LO HXW 1/2	2
0375	WR23X10330	HARNESS MOTOR & SOL	1
0377	WR02X7309	SADDLE SOLENOID	1
0378	WR62X0058	SOLENOID & ARM ASM	1
0379	WR17X1063	SHROUD SOLENOID	1

VIEW NUMBER	CATALOG NUMBER	DESCRIPTION	QUANTITY
0380	WR17X1064	PLUNGER SOLENOID	1
0381	WR02X4257	PIN SPIRAL	1
0382	WR02X4258	SPRING SOLENOID LINKAGE	1
0383	WR17X1065	COLLAR SOLENOID DISP	1
0384	WR17X1066	STIRRUP SOLENOID DISP	1
0385	WR02X4259	PIN SPIRAL	1
0386	WR02X11767	BOOT AUGER MOTOR INT	1
0387	WR17X11478	COVER BUCKET BOTTOM	1
0400	WR01X10209	WHEEL PAN COVER	8
0401	WR01X10214	SCR 10-16 PL PNP 5/8 SZN	8
0405	WR02X11254	DIFFUSER FF INLET LT	1
0405	WR02X11255	DIFFUSER FF INLET RT	1
0407	WR32X10339	PAN MIDDLE CHILL ASM	1
0409	WR32X10200	COVER PAN GLASS	1
0410	WR32X10197	COVER MIDDLE PAN	1
0413	WR02X10650	HUMIDITY CONTROL	1
0414	WR14X10059	GASKET PAN CRV FRONT	1
0417	WR14X10058	GASKET PAN CRV REAR	1
0418	WR02X10633	SLIDE MIDDLE PAN COVER	1
0421	WR55X10389	INTERFACE CUSTOMER ASM	1
0433	WR02X9391	SOCKET & TERMINAL ASM	4
0434	WR02X10645	SOCKET LAMP	2
0435	40A15	LAMP 40 W	4
0437	60A	LAMP 60 W	2
0447	WR02X10831	COVER HINGE FZ BK	1
0448	WR13X10214	HINGE TOP & PIN ASM FZ	1
0449	WR13X10215	HINGE TOP & PIN FF	1
0450	WR02X10832	COVER HINGE FF BK	1
0451	WR13X10126	HINGE BTM WH	1
0453	WR23X10209	HARNESS/TSTAT FF LT	1
0454	WR01X10212	NUT 8-32	2
0456	WR71X10595	BEZEL LIGHT FF	1
0470	WR32X10196	COVER TOP PAN ASM	1
0471	WR32X10338	PAN ASM TOP	1
0481	WR31X10036	TRAY CUSTOM COOL	1
0482	WR17X11787	WIREFRAME PAN	1
0487	WR32X10434	PAN FRAME ASM	1
0501	WR71X10296	SHELF SLIDEOUT ASM	2
0505	WR02X10662	STOP SHELF	3
0530	WR71X10294	SHELF TUCKAWAY ASM	1
0540	WR31X10038	COVER PAN ASM	1
0552	WR01X2022	SCREW	10

VIEW NUMBER	CATALOG NUMBER	DESCRIPTION	QUANTITY
0553	WR01X10314	SCREW HANDLE MTG	6
0580	WR72X10140	SLIDE AND BRACKET ASM	2
0581	WR72X10141	SLIDE LINER	2
0582	WR72X10142	SPACER SLIDE	2
0583	WR01X10399	SCR 8-18 AB HW 1/2 S	6
0602	WR01X1591	SCR 1/4-14 X 3/4	2
0608	WR23X10179	SWITCH LIGHT	1
0609	WR23X10175	SWITCH LIGHT	1
0610	WR60X10099	MOTOR DC EVAP FAN ASM	1
0611	WR02X10764	BRACKET EVAP FAN BTM	1
0612	WR02X10653	BRACKET ORIFICE FAN	1
0613	WR60X10075	BLADE EVAP FAN ASM	1
0614	WR02X10540	BUMPER LID	3
0615	WR02X10519	GROMMET EVAP FAN	2
0616	WR82X10093	COVER ACCESS	1
0618	WR02X11331	GROMMET EVAP FAN	2
0625	WR01X5278	CLAMP CABLE	2
0626	WR23X0108	HARNESS CORD POWER	1
0610	WR60X10043	MOTOR DC EVAP FAN ASM	1
0626	WR23X0108	POWER CORD	1
0628	WR17X11252	SHROUD CONDENSER	1
0650	WR60X10080	MOTOR DC COND FAN	1
0651	WR60X10049	BLADE COND FAN ASM	1
0652	WR02X10509	RING COMPRESSION	2
0653	WR02X10322	CAP DUST	1
0616	WR82X10071	COVER ACCESS	1
0683	WR02X11027	WIRE TIE	1
0686	WR01X10252	SCR 10-32 TT HW 5/16 S	10
0690	WR01X1466	SCR 8-32 T HW 3/8 S	7
0626	WR23X10300	HARNESS CORD POWER	1
0691	WR02X10593	BRACKET COND FAN (REAR)	1
0725	WR87X10064	INVERTER COMPRESSOR EMB	1
0626	WR23X10300	POWER CORD	1
0727	WR17X11503	SEPARATOR AIR HISIDE	1
0730	WR84X10022	CONDENSER ASSEMBLY	1
0650	WR60X10065	MOTOR DC COND FAN	1
0734	WR02X11262	COVER RELAY (EMB)	1
0736	WR02X8203	CLIP COMPRESSOR MOUNT	4
0737	WR02X10099	GROMMET	4
0740	WR86X10030	DRYER BIFURCATED HX9	1
0741	WR01X1779	STUD MTG COMPR	4
0749	WR17X11039	BAFFLE COND AIR	1
0750	WR01X1786	SCREW 10-32 TR 1/2	4

VIEW NUMBER	CATALOG NUMBER	DESCRIPTION	QUANTITY
0690	WZ5X158D	SCR 8-32 T HXW 3/8 S	7
0751	WR17X10693	BASEPLATE HIGH SIDE	1
0753	WR02X10521	BRKT COND FAN (MTG)	1
0757	WR01X10193	SCR 10-32 SPECIAL	6
0758	WD02X0323	SCR 8-32 X 3/8 SPH	2
0762	WR02X11857	FOAM STRIP SE ADH	1
0764	WR02X9000	CLIP, COND MNT	2
0765	WR17X10763	BRACKET CONDENSER BAR	1
0775	WR17X10796	COVER WATER LINE	1
0734	WR02X11262	COVER RELAY (EMB)	1
0790	GWF	FILTER CANISTER	1
0791	WR02X11705	CAP FILTER BYPASS	1
0792	WR17X11028	FILTER ASM AND TUBE	1
0800	WR57X10040	WATER VALVE	1
0801	WR55X10414	BOARD ASM MAIN CONTROL	1
0802	WR23X10382	HARNESS BOARD INDIV	1
0803	WR02X11847	MAIN BOARD ENCLOSURE ASM	1
0805	WR02X3736	STR RELIEF	1
0751	WR17X10693	BASEPLATE HIGH SIDE	1
0806	WR17X11625	TUBE PLASTIC	1
0808	WR02X4039	ADHESIVE CLIP	1
0757	WR01X10194	SCR 10-32 SPECIAL	6
0809	WR01X1936	FASTENER WATER TUBE	1
0758	WD2X323D	SCR 8-32 X 3/8 SPH	2
0810	WR17X11709	COVER TANK WATER COIL AS	1
0813	WR17X11710	COVER WATER TANK	1
0814	WR85X10060	LOW SIDE ASM FF	1
0815	WR17X11708	TROUGH DRAIN ASM	1
0816	WR17X11844	COVER EVAP ASM FF	1
0820	WR30X10044	ICEMAKER ASM	1
0821	WR02X11548	STRIPPER IM	1
0842	WR11X10007	LEVER ASM FF SIDE WH	1
0792	WR17X11618	FILTER ASM AND TUBE	1
0843	WR11X10008	LEVER ASM FZ SIDE WH	1
0800	WR57X10032	WATER VALVE	1
0847	WR01X2027	SPRING CLOSURE	2
0801	WR49X10092	BOARD ASM MAIN CONTROL	1
0867	WR29X10058	CUP FILL IM	1
0870	WR23X10381	HARNESS INVERTER COMM	1
0803	WR02X11473	MAIN BOARD ENCLOSURE ASM	1
0871	WR55X10155	INVERTER ASM EMBRACE	1
0900	WR78X10860	DOOR FOAM ASM FZ WH	1
0903	WR01X10208	THIMBLE DOOR BTM FZ WH	1

VIEW NUMBER	CATALOG NUMBER	DESCRIPTION	QUANTITY
0904	WR01X10375	SCREW DOOR STOP T20	4
0905	WR01X2134	SCR 10-32 PNT 1.0 S LW	2
0910	WR78X10600	DOOR FOAM ASM FF WH	1
0911	WR01X10207	THIMBLE DOOR TOP WH	2
0912	WR01X10206	THIMBLE DOOR BTM WH	1
0915	WR02X10844	GRILL MULLION	1
0920	WR31X10008	COVER UPPER	1
0921	WR31X10043	COVER LOWER	1
0922	WR60X10064	FAN CHILL	1
0923	WR60X10063	DAMPER ASM DESUPPLY	1
0820	WR30X10012	ICEMAKER ASM	1
0924	WR60X10062	DAMPER ASM SUPPLY	1
0925	WR31X10007	PLENUM TOP	1
0926	WR31X10009	DUCT CAVITY CHILL	1
0927	WR14X10095	GASKET MULLION DUCT	1
0930	WR51X10049	HEATER THAW	1
0931	WR02X10809	REFLECTOR	1
0932	WR14X10096	GASKET DAMPER CHILL	1
0933	WR31X10012	LIGHT SOCKET CHILL	1
0934	WR02X10812	LAMP 40W CHILL	1
0935	WR31X10010	GRILL BULB CHILL	1
0936	WR14X10092	SEAL AHU CHILL	1
0937	WR23X10384	HARNESS CHILL AC	1
0938	WR23X10237	HARNESS CHILL DC	1
0939	WR14X10090	SEAL AHU CHILL	1
0941	WR14X10091	SEAL AHU CHILL	1
0942	WR01X10239	WASHER RETAINER CHILL	4
0944	WR14X10093	GASKET LC	1
0945	WR14X10094	GASKET UC	1
0960	WR17X11842	GROMMET DRAIN TUBE ASM	1
0971	WR02X11789	BRACKET INVERTER	1
0980	WR57X10053	VALVE ASM	1
1022	WR17X11272	CAP TRIM BTM FZ WH	1
1024	WR17X10972	TRIM DOOR BTM FZ WH	1
1025	WR12X10538	HANDLE ASM TRIM FZ WH	1
1026	WR17X11273	TRIM DOOR SIDE FZ WH	1
1027	WR17X10974	TRIM DOOR TOP FZ WH	1
1042	WR17X11271	CAP TRIM BTM FF WH	1
1044	WR17X10973	TRIM DOOR BTM FF WH	1
1045	WR12X10539	HANDLE ASM TRIM FF WH	1
0930	WR51X10081	HEATER THAW	1
1046	WR17X11274	TRIM DOOR SIDE FF WH	1
1047	WR17X10975	TRIM DOOR TOP FF WH	1

Warranty



All warranty service provided by our Factory Service Centers, or an authorized Customer Care® technician. To schedule service, on-line, 24 hours a day, visit us at GEAppliances.com, or call 800.GE.CARES (800.432.2737).

For The Period Of:	GE Will Replace:
One Year From the date of the original purchase	Any part of the refrigerator which fails due to a defect in materials or workmanship. During this full one-year warranty , GE will also provide, free of charge , all labor and in-home service to replace the defective part.
Five Years From the date of the original purchase	Any part of the sealed refrigerating system (the compressor, condenser, evaporator and all connecting tubing) which fails due to a defect in materials or workmanship. During this full five-year sealed refrigerating system warranty , GE will also provide, free of charge , all labor and in-home service to replace the defective part in the sealed refrigerating system.
Lifetime of Product From the date of the original purchase	The full extension slides , if they should fail due to a defect in materials or workmanship. During this product lifetime limited warranty , you will be responsible for any labor or related service costs.
Thirty Days From the original purchase date of the refrigerator	Any part of the water filter cartridge which fails due to a defect in materials or workmanship. During this limited thirty-day warranty , GE will also provide, free of charge , a replacement water filter cartridge.

What GE Will Not Cover:

- Service trips to your home to teach you how to use the product.
- Improper installation, delivery or maintenance.
- Failure of the product if it is abused, misused, or used for other than the intended purpose or used commercially.
- Loss of food due to spoilage.
- Replacement of house fuses or resetting of circuit breakers.
- Damage caused after delivery.
- Replacement of the water filter cartridge due to water pressure that is outside the specified operating range or due to excessive sediment in the water supply.
- Replacement of the light bulbs or water filter cartridge other than as noted above.
- Damage to the product caused by accident, fire, floods or acts of God.
- Incidental or consequential damage caused by possible defects with this appliance.

This warranty is extended to the original purchaser and any succeeding owner for products purchased for home use within the USA. In Alaska, the warranty excludes the cost of shipping or service calls to your home.

Some states do not allow the exclusion or limitation of incidental or consequential damages. This warranty gives you specific legal rights, and you may also have other rights which vary from state to state. To know what your legal rights are, consult your local or state consumer affairs office or your state's Attorney General.

Warrantor: General Electric Company. Louisville, KY 40225