

Service Bulletin

NOVEMBER 2007

REFRIGERATORS
DUAL EVAPORATOR SIDE-BY-SIDE REFRIGERATORS
SERIAL NUMBERS AG - ZM
ICE BALL KIT
WR49X10180 (DOMESTIC 120V)
WR49X10175 (INTERNATIONAL 220V)

REF 11-07

FRESH FOOD ICE BALL

Dual Evaporator models, by design, create a high humidity environment in the fresh food section. Although this design improves the preservation of certain refrigerated foods, the potential exists in some units for an ice ball to form in the lower section of the compartment due to excessively cold temperatures and high humidity. The low temperatures are created by gaps around the beverage center duct and along the left side of the Custom Cool air handler cover. These locations can be sealed and the temperature improved using the service kit **WR49X10180** (120V heater) or **WR49X10175** (220V heater). Refer to the attached kit instructions for the proper repair method.

Models Affected: PSF26P, PSS26P, PSW26P, PSF26R, PSW26R, PCF23P, PSC23P, PSH23P, PSW23P, PCF23R, PSW23R, PCF25M, PSC25M, PCF25N, PSC25N, PCF25P, PSH25P, PSC25P, PSH25P, ZFSB23D, ZFSB26D

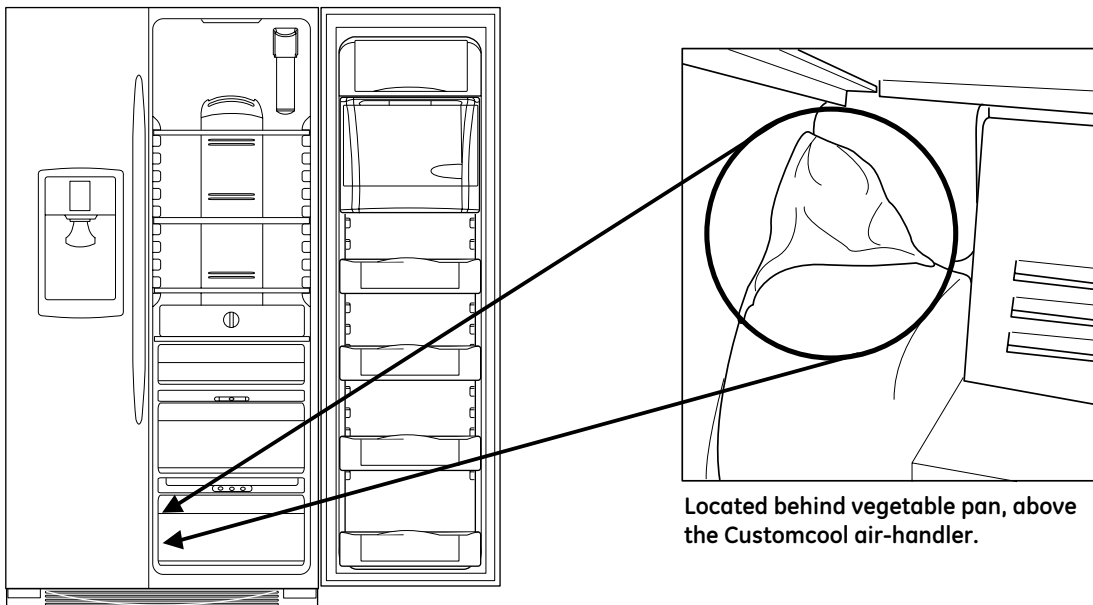

Located behind vegetable pan, above the Customcool air-handler.



GE Appliances
General Electric Company
Louisville, Kentucky 40225

GE CONFIDENTIAL AND PROPRIETARY INFORMATION—NOT FOR PUBLIC DISCLOSURE

Installation Instructions

WR49X10180 Kit-Domestic

WR49X10175 Kit-International



BEFORE YOU BEGIN

Read these instructions completely and carefully.

IMPORTANT – Observe all governing codes and ordinances.

Note to Installer – Be sure to leave these instructions with the Consumer.

Note to Consumer – Keep these instructions with your Owner's Manual for future reference.



WARNING:

To prevent electric shock, disconnect electrical power supply to refrigerator before beginning kit installation.

TOOLS AND MATERIALS NEEDED:

- Phillips screwdriver
- Flathead screwdriver
- 5/16" hex head nut-driver
- Razor knife
- Tape
- Drill

KIT CONTENTS:

- AC foil heater assembly
- Wire ties (3)
- Crimp style wire connectors (3)
- Aluminum tape – 1-1/4"
- White vinyl tape – 1-1/2"
- Jumper harness
- Grommet
- RTV102 (2)
- EPS beverage center L-insert
- Fresh food evaporator EPS block
- Air return EPS block
- Evaporator tube foam insulation
- Beverage center duct
- 1/2" Pilot tip drill bit

The ice ball problem is being caused by very low temperatures in the lower left part of the fresh food compartment. The low temperatures are being driven by two gaps that need to be sealed. One around the beverage center duct and one along the left side curved geometry of the Quick Chill air handler cover. These two locations need to be sealed with RTV.

▲ REMOVE POWER TO THE UNIT BEFORE PERFORMING KIT INSTALL.

▲ REMOVE ALL ICE AND MOISTURE FROM ALL REPAIR AREAS.

▲ SOME 25 CU. FT. BIS MODELS DO NOT HAVE BEVERAGE CENTERS.

▲ CHECK FOR WIRES ALREADY ROUTED WITH DC (RIGHT FRONT) HARNESS IN FRESH FOOD COMPARTMENT. IF THERE ARE WIRES THERE, A DC KIT HAS BEEN INSTALLED. IF DC KIT WAS INSTALLED ALREADY, CONNECTION TO MAIN BOARD MUST BE REMOVED AND HARNESS CUT SHORT.



Step 1

Remove the bottom three bins and lower shelf in the fresh food compartment. Remove any ice inside the fresh food side of the unit. Check under the quick chill assembly. Clean and dry the area, as well as the sump.

Step 2

Remove the beverage center duct cover and the evaporator line cover. Remove the fresh food evaporator cover via the three (3) screws attaching it (Figure 1). Tilt the assembly out of the way of the beverage center duct. It is not necessary to disconnect the fans. Remove any ice present and dry the area thoroughly. Should Fresh Food Evaporator EPS Block or Air Return EPS Block become damaged in this process, utilize replacement pieces in kit.

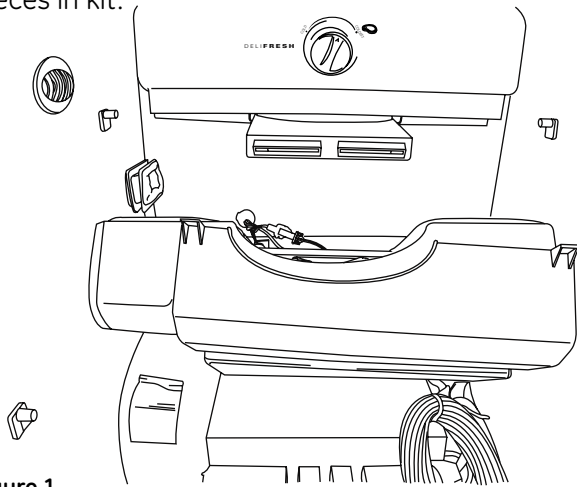

Figure 1

Step 3

Remove Beverage Center Duct and replace with new duct from kit, liberally applying RTV to seal Duct in place. RTV completely around the Duct including behind and below, smoothing on with finger is preferred method. Cover as much of the gasket area as possible (Figure 2). Install the EPS L-insert per Figure 2.

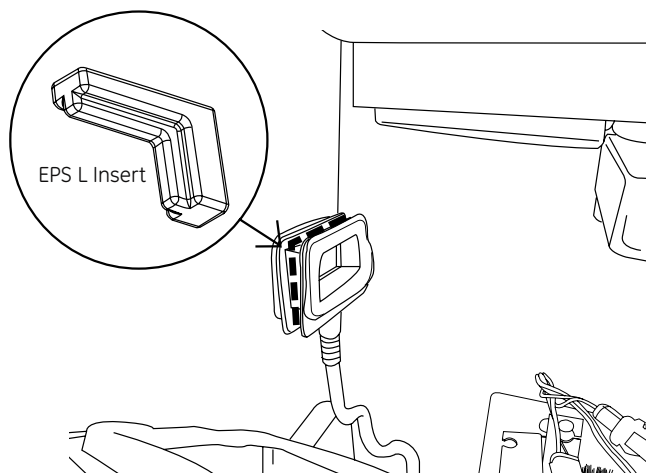

Figure 2

Step 4

Apply a liberal bead of RTV along the space between the custom cool cover and the left sidewall (Figure 3). Smooth to ensure a clean appearance.

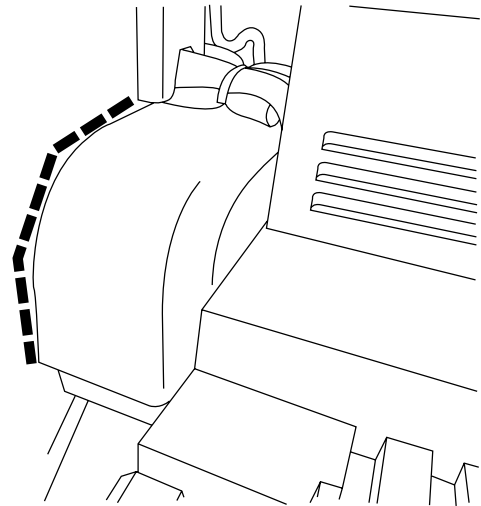

Figure 3

Step 5

Apply a liberal amount of RTV102 to the underside of the 3-watt AC heater assembly. Follow the INSIDE of the lip on the bottom of the heater assembly (Figure 4). Ensure the RTV will make contact around the entirety of the heater assembly when applied to the custom cool cover.

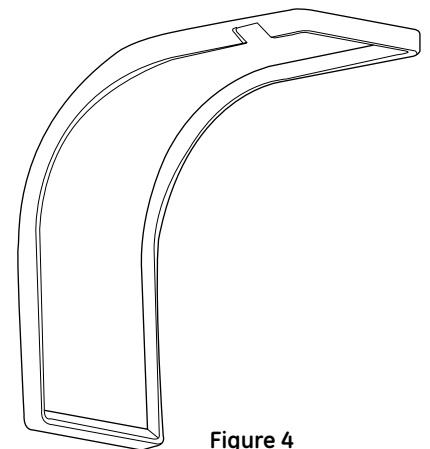

Figure 4

Step 6

Position heater assembly on custom cool cover, making sure heater assembly is directly touching the left sidewall (Figure 5). Heater assembly should fit custom cool cover geometry snugly. Ensure that the heater assembly goes all the way back to the evaporator tube cover.

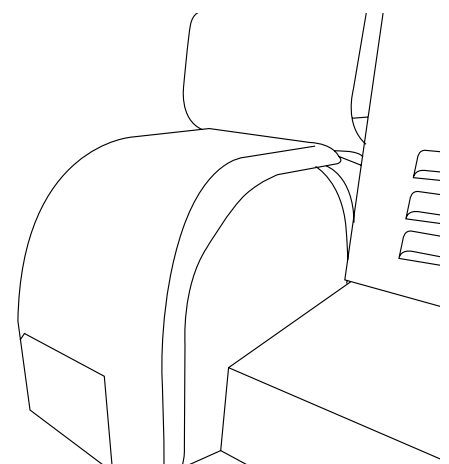

Figure 5

Step 7

Apply aluminum tape to the front of the heater assembly. Starting back under the Quick Chill assembly and coming up the front of the heater assembly about 2.5" (Figure 6). Keep the tape as close to the left side fresh food wall as possible.

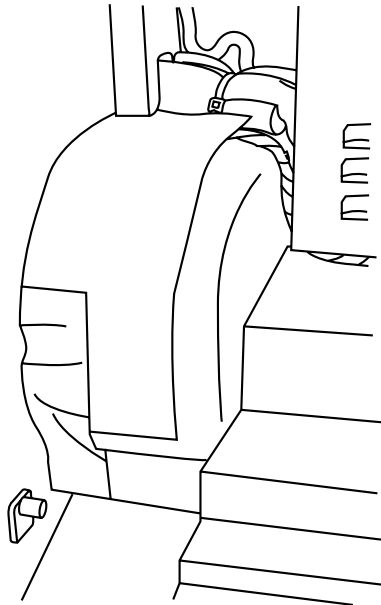

Figure 6

Step 8

Cover aluminum tape with white vinyl tape.

Step 9

Route heater wire under evaporator cover as far as possible for as little consumer exposure as possible.

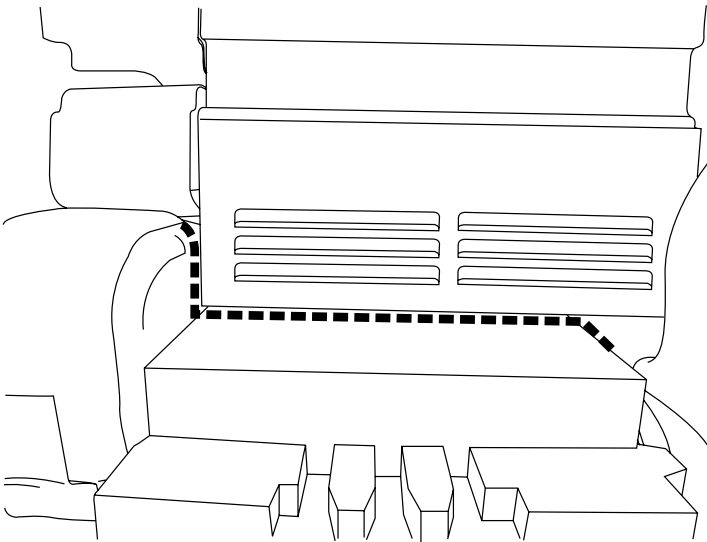

Figure 7

Step 10

Replace evaporator tube cover. Move evaporator cover back into position and replace screws. Remove the cold water reservoir plastic cover. Position the reservoir coils as clear of the right front DC grommet as possible (Figure 8).

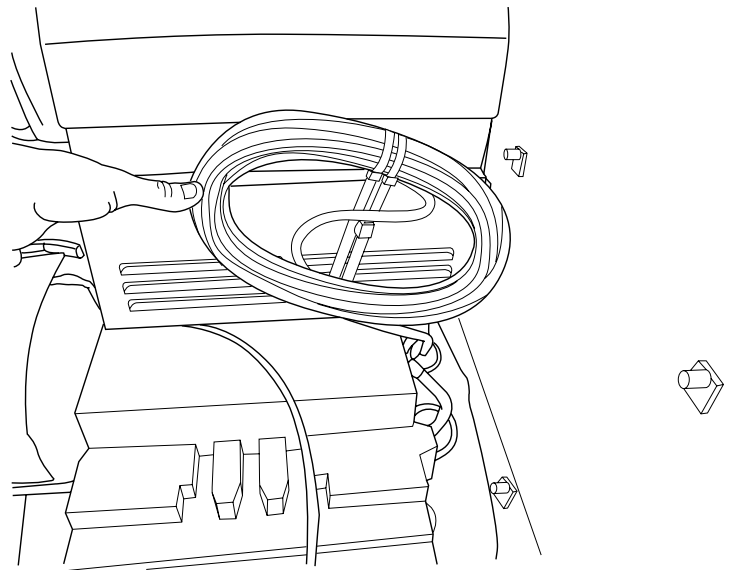

Figure 8

Step 11

- ▲ Ensure power to unit is disconnected before drilling.
- ▲ Check for Flow Meter wiring harness clearance in doghouse before drilling.
- ▲ If the unit has precise fill feature, check for wire harness clearance in doghouse before drilling. If wires are in the way, adjust hole location accordingly.

Drill a 1/2" hole straight down into the machine compartment. Locate the hole in front of the right front DC grommet. Hole should be 1" in front of DC grommet edge and 2" from right liner wall (Figure 9).

Drill perpendicular to the surface.

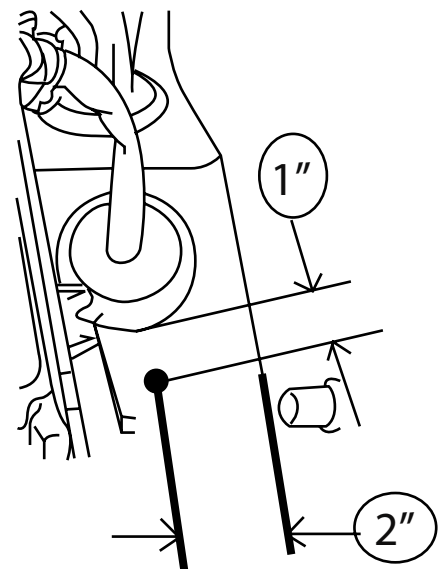

Figure 9

Step 12

RTV around the underside of the grommet lip (Figure 10). Insert grommet into hole. Ensure it is pressed completely in, until the base of the grommet lip touches the fresh food floor surface. Clear excess RTV for clean appearance.

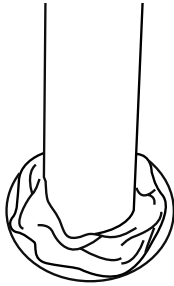

Figure 10

Step 13

Use a wire tie to attach the heater wire to the AC harness (right rear harness) for strain relief inside the fresh food compartment. Clip off excess wire tie. Keep the spacing between the heater wire and the DC (right front) harness as large as possible (Figure 11).

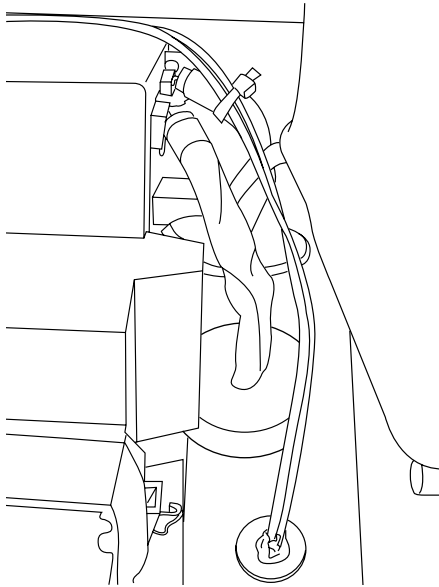

Figure 11

Step 14

Route the heater assembly wire down through the installed grommet. Fill inside of grommet around harness with RTV to prevent air leaks (Figure 12).

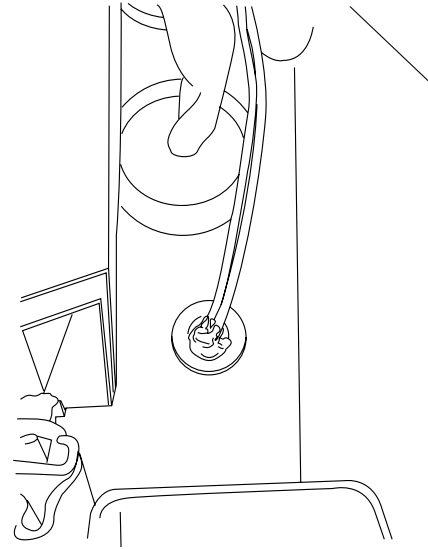

Figure 12

Step 15

Reinstall all fresh food compartment components. Pull out unit. Remove machine compartment cover.

Step 16

Remove the water valve assembly to provide clearance to connect wiring.

Step 17

Use a wire tie to attach the heater wire to the AC harness as a strain relief in the machine compartment. Try to keep spacing between the heater wire and the rear entering DC harness as large as possible (Figure 13).

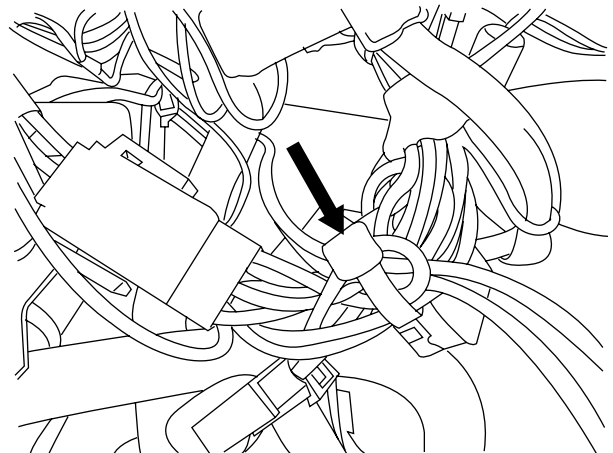

Figure 13

Step 18

Use the bell/crimp style wire connectors to connect the heater wiring to the jumper harness (Figure 14).

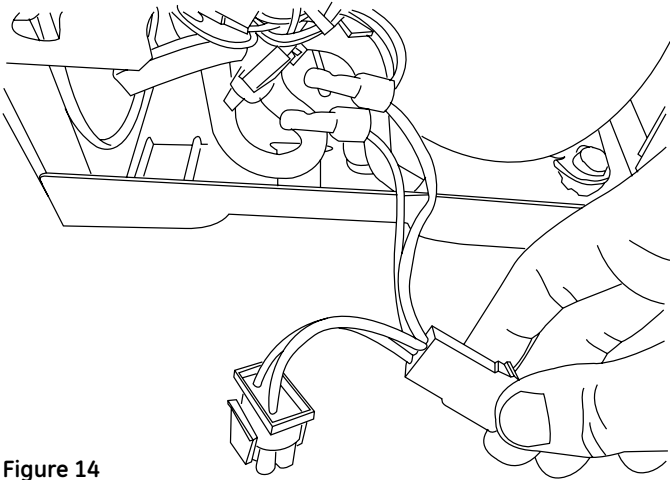

Figure 14

Step 19

Disconnect main power cord 6-pin connector. Place heater jumper harness in line (Figure 15). Coil excess wiring and wire tie. Tuck excess wiring back in machine compartment (Figure 16). Ensure that all harness connectors are secure; some may be loose from factory.

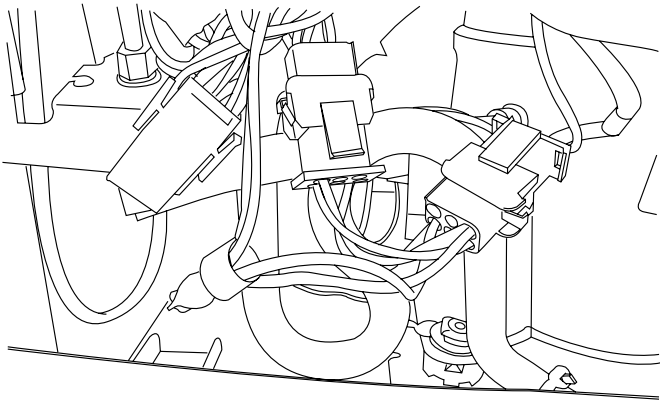

Figure 15

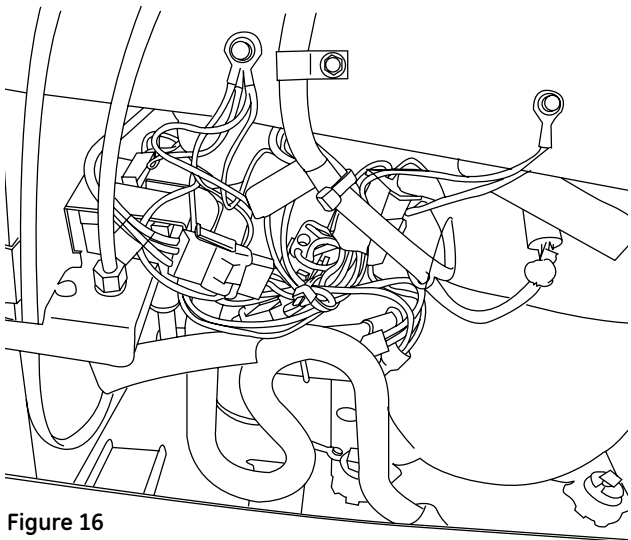

Figure 16

Step 20

Apply power back to unit and ensure both unit and heater are operational. Listen for compressor and feel heater with back of hand. Heater surface will be slightly warmer than surrounding left wall surface. Go back and ensure that heater assembly is directly touching the left sidewall. Heater may have shifted during wire routing.

Step 21

Replace cover on machine compartment. Ensure that no wires are being pinched between the cover and the case back. Replace unit to original position in home.

Step 22

Remove plate covering water tube to the filter (Figure 17). RTV sealing the tubes to the foam to prevent any possible air leaks.

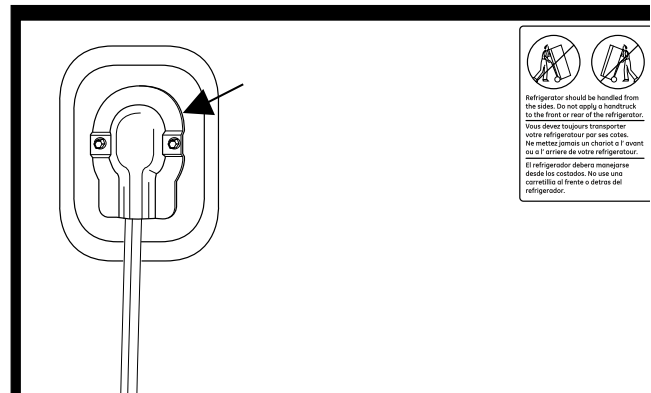

Figure 17

Step 23

Check gasket around fresh food door and freezer door for tears or gasket rollover. Repair/replace as necessary.

ClimateKeeper2™ dual evaporator technology

Temperature and humidity control

- Two separate climates
- no air crossover
- **higher humidity in fresh food**
- fewer defrost cycles
- no taste transfer



SPECIFICATIONS SUBJECT TO CHANGE WITHOUT NOTICE

GE Consumer & Industrial
General Electric Company
Louisville, Kentucky 40225

ge.com

© 2007 General Electric Company
Dwg. No. 225D1974P003
Pub. No. 31-46511
ND 07G-2330