

Service Bulletin

OCTOBER 2007

REFRIGERATORS
METAL LINER SIDE-BY-SIDE MODELS
BUILT JANUARY 2003 THROUGH
JANUARY 2007 (AF-AM MODELS)

REF 10-07

WATER LINE FREEZING

Moisture migration into door foam may cause dispenser tube to freeze, resulting in no water dispensed.

MODELS AFFECTED

All metal liner SxS production built January 2003 through January 2007 (serial numbers AF through AM):

Models BSS, DSS, ESH, GSH, GSS, GST, HSS, SSS

REPAIR/RESOLUTION

Install service kit **WR49X10173**, dispenser heater.

- Remove the board and cradle assembly from the dispenser housing.
- The heater will be applied to the recessed area below the ice duct door. **Note:** Clean and dry this area as thoroughly as possible.
- Peel the paper backing off of the heater and apply it in the recessed area below the ice duct door. Press firmly over the entire surface to ensure adequate adhesion, forming it around the dispenser tube as necessary.
- Route the white lead wires to the dispenser housing to the left of the ice duct door, as shown, to prevent the wires from interfering with the duct door. Make sure the wires do not interfere with ice/water path or movement of the duct door.
- Connect heater wires to wire harness using the red fold-over splices provided. Do not cut wires on the unit. If there is no heater already installed on the ice duct door, attach heater wires to the red wire on pin 2 and black wire on pin 6 as shown in the figure at right below. If there is an ice duct door heater kit installed, the instructions for the kit specify a different method that must be used to properly attach the heater.

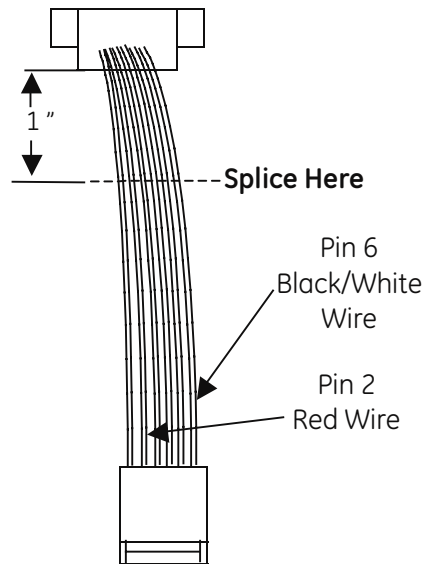
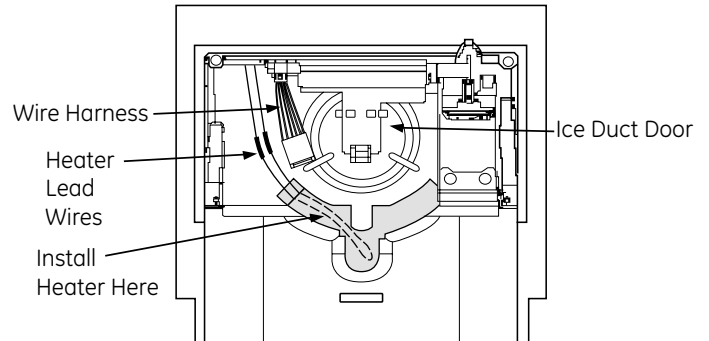

GE Appliances
General Electric Company
Louisville, Kentucky 40225

GE CONFIDENTIAL AND PROPRIETARY INFORMATION—NOT FOR PUBLIC DISCLOSURE

WR49X10173 – Dispenser Water Tube Heater Kit Installation Instructions

Supersedes All Previous Instructions

This service part must be installed by the technician.

***NOTE: This kit is specifically designed for refrigerator models with metal liners.**

Prior to Installation, please verify "no water dispense" is root caused to frozen water line. The quickest way to determine if the failure is due to a frozen water line is to first ensure that water does NOT dispense. Next, disconnect the blue connector at the bottom of the door and ensure that water flows when the paddle is pressed. Use a cup/container to avoid a water spill while conducting this test.

1. Remove the board and cradle assembly from the dispenser housing.

2. The heater will be applied to the recessed area below the ice duct door. **See Figure 1.** Clean this area as thoroughly as possible.

3. Peel the paper backing off of the heater and apply it in the recessed area below the ice duct door. **See Figure 1.** Press firmly over the entire surface to ensure adequate adhesion, forming it around the dispenser tube as necessary.

4. Route the heater lead wires to the dispenser housing to the left of the ice duct door, as shown in **Figure 1**, to prevent the wires from interfering with the duct door.

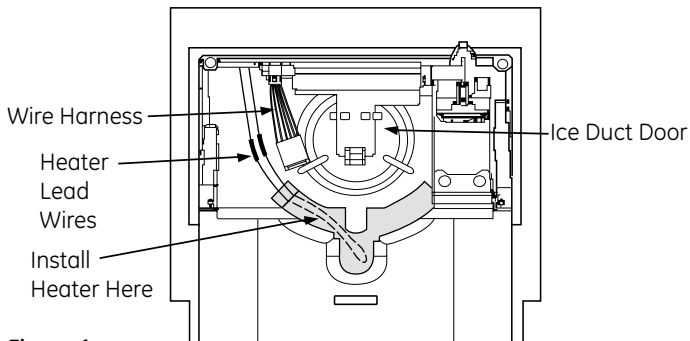

Figure 1

5. Connect heater wires using the red fold-over splices provided. Do NOT cut wires on the unit; instructions for proper use of splice connectors are below. Depending on how the refrigerator is equipped, there are two methods for installation:

If there is NO heater kit installed on the ice duct door, attach heater wires to red wire on pin 2 and black and white wire on pin 6. Attach splices 1" from the grommet where the wires come out of the top of the dispenser recess. **See Figure 2.**

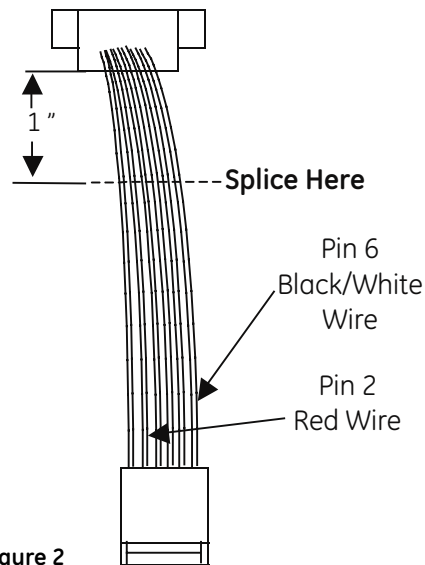

Figure 2

NOTE: Red splice connectors (included in kit) are for Low Voltage DC only.

If there IS a heater kit installed on the ice duct door, attach heater wire leads of this kit to the wire leads from the ice duct door heater 2" from the splice connectors that attach the ice duct door heater to the wires on pins 2 and 6. Ensure that the wires are not interfering with the ice duct door, and that ice has an unrestricted path into the dispenser recess area. If possible, bunch up the excess wire leads from both heaters and use a wire tie to keep them together and out of the way. Leave enough slack in the leads to allow for proper function of the ice duct door and for reconnection of the wires to the control board. See Figure 3.

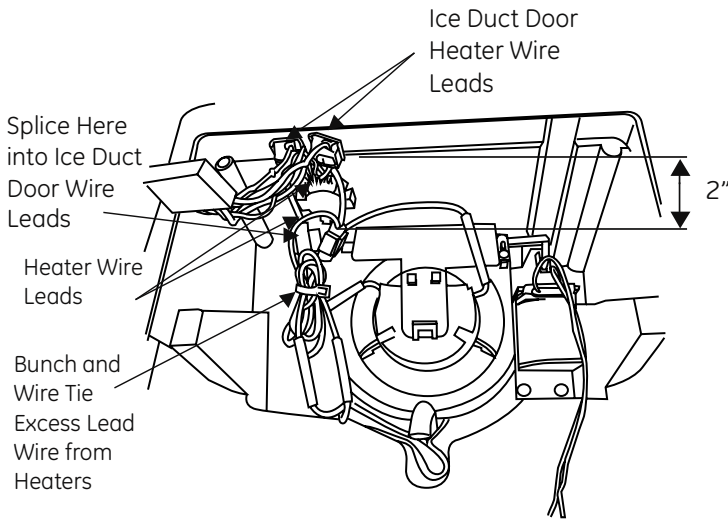

Figure 3

To properly use each red splice connector, position the heater wire into the side of splice connector that does not allow the wire to pass all the way through: Insert the appropriate wire (from pin 2/6) into the other side of the splice connector. Hold the wires securely in place before crimping the metal conductor gate on the splice connector using pliers. Avoid using too much force, but crimp until the metal gate conductor is flush with the red plastic housing. Complete the connection by folding the red plastic flap over the crimped metal conductor gate. See Figure 4.

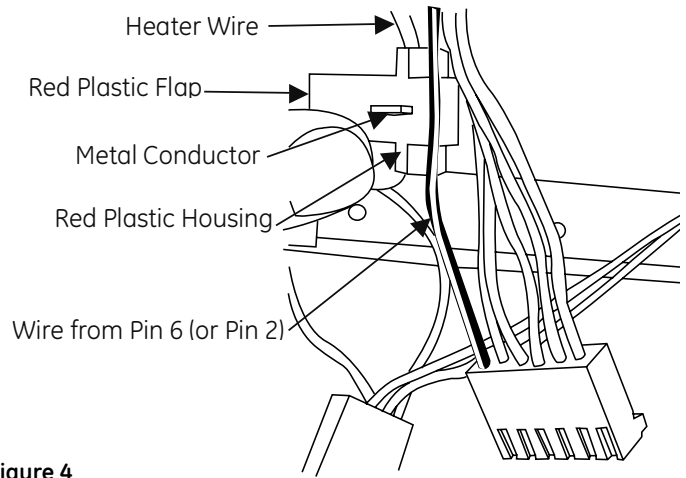

Figure 4

6. Check heater functionality using your finger to ensure heater is warm after approximately one minute after connecting the heater wires. To get power to the heater, temporarily plug the 6-prong connector into the control board.

7. Replace dispenser cradle assembly and control board. See Figure 5 for wire routing.

*NOTE: It could take up to a day for the heater to thaw ice/enable water to flow properly from the dispenser.

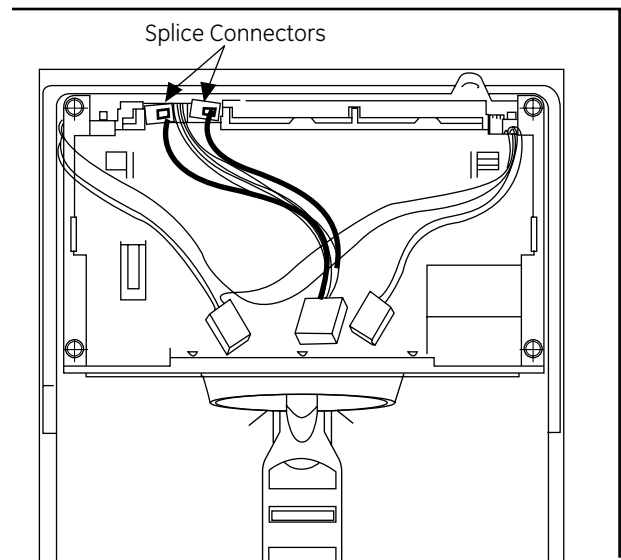

Figure 5