

DISCONNECT POWER CORD BEFORE SERVICING
IMPORTANT - RECONNECT ALL GROUNDING DEVICES

All parts of this appliance capable of conducting electrical current are grounded. If grounding wires, screws, straps, clips, nuts or washers used to complete a path to ground are removed for service, they must be returned to their original position and properly fastened.

IMPORTANT SAFETY NOTICE

This information is intended for use by individuals possessing adequate backgrounds of electrical, electronic and mechanical experience. Any attempt to repair a major appliance may result in personal injury and property damage. The manufacturer or seller cannot be responsible for the interpretation of this information, nor can it assume any liability in connection with its use.

ELECTRICAL SPECIFICATIONS

Temperature Control (Position 5) 37-22°F.
 Defrost Control 16 hrs. @ 35 min.
 Defrost Thermostat 60-28°F.
 Electrical Rating: 115V. AC 60 Hz. 11.6 Amp.
 Maximum Current Leakage 0.50 mA.
 Maximum Ground Path Resistance 0.14 Ohms
 Energy Consumption 88 KWH/mo.

NO LOAD PERFORMANCE

Control Position 5/C
 and Ambient of:

	70°F.	90°F.
Fresh Food, °F.	33-39	37-41
Frozen Food, °F.	2-8	(-1)-3
Run Time, %	33-43	54-70

REFRIGERATION SYSTEM

Refrigerant Charge (R-12) 6¼ ounces
 Compressor 1042 BTU/hr.
 Minimum Compressor Capacity 23 inches
 Minimum Equalized Pressure
 @ 70°F. 37 PSIG
 @ 90°F. 46 PSIG

INSTALLATION

Clearance must be provided for air circulation:
 AT TOP 1-inch
 AT SIDES 5/8-inch
 AT REAR 1-inch

AIR FLOW

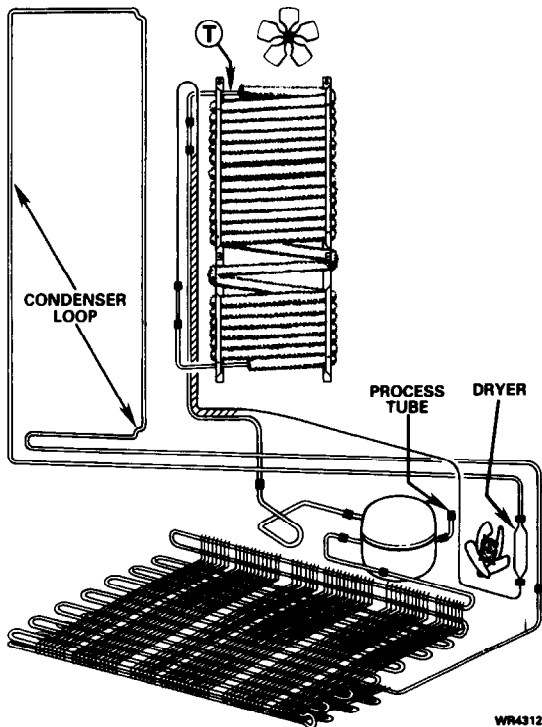
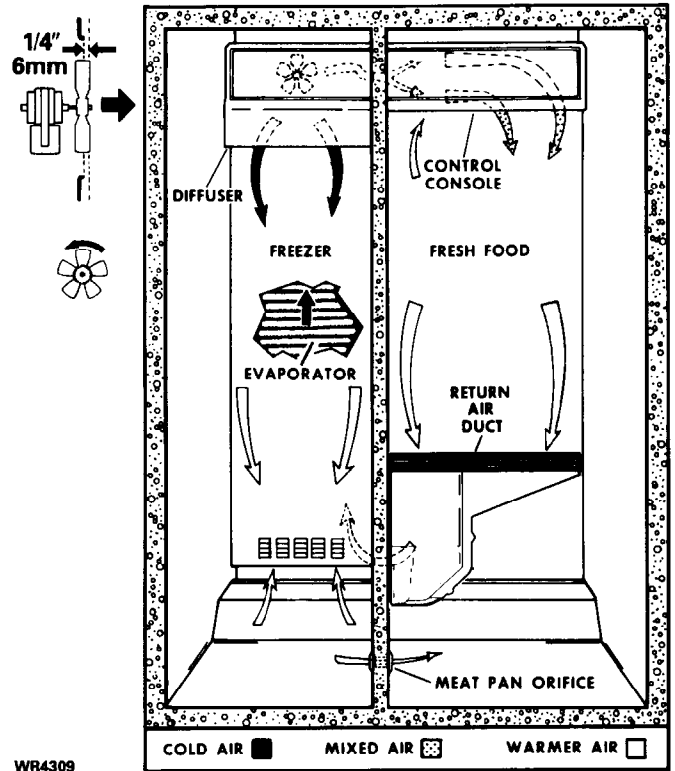

REPLACEMENT PARTS

Temperature Control	WR09X0499
Relay	WR07X0198
Overload	WR08X0114
Run Capacitor	WR62X0052
Defrost Control	WR09X0489
Defrost Thermostat	WR50X0122
Defrost Heaters & Harness	WR51X0372
Condenser Fan Motor	WR60X0179
Evaporator Fan Motor	WR60X0188