

Electronic Refrigerator Diagnostics

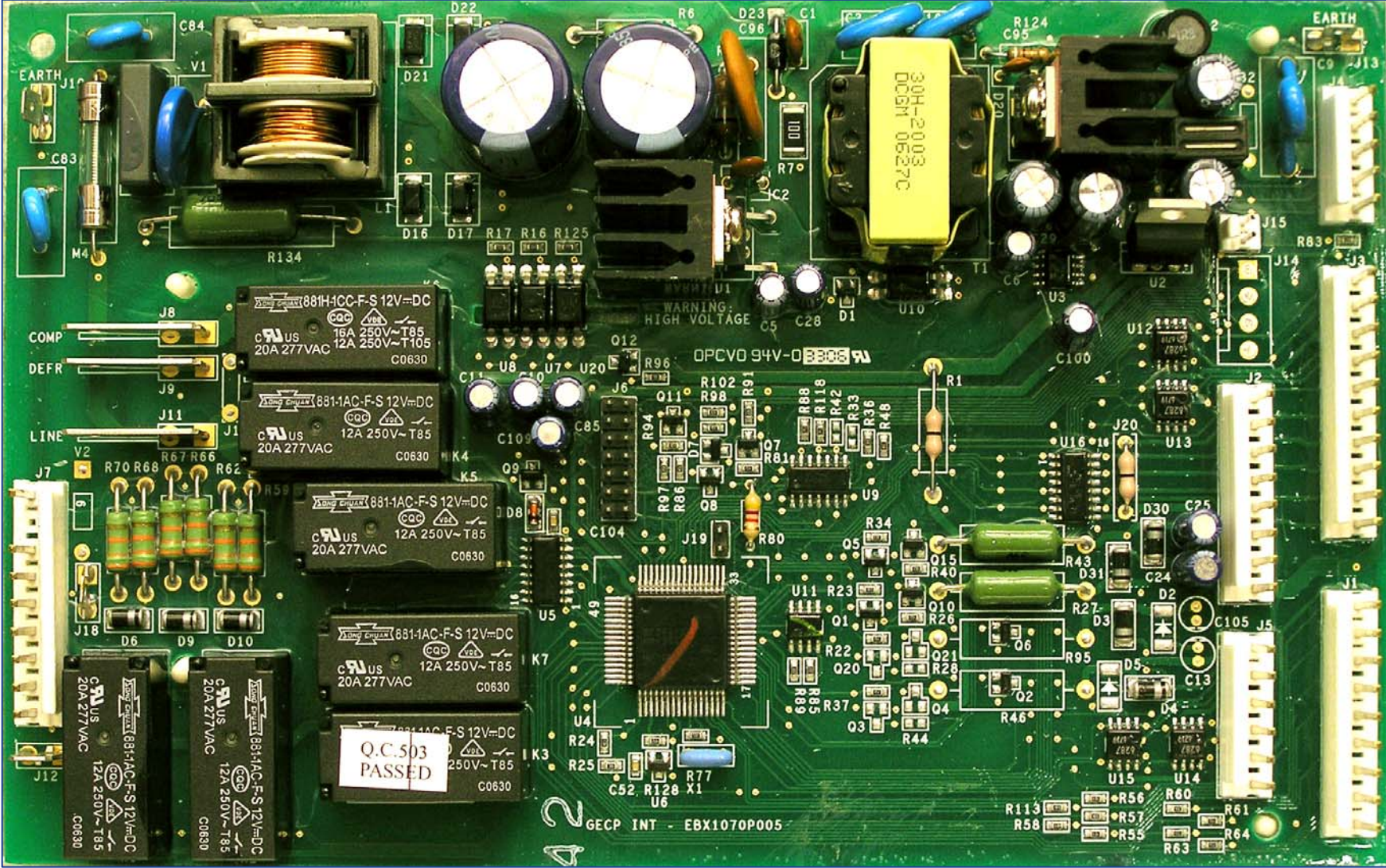

IMPORTANT SAFETY NOTICE

The information in this presentation is intended for use by individuals possessing adequate backgrounds of electrical, electronic, & mechanical experience. Any attempt to repair a major appliance may result in personal injury & property damage. The manufacturer or seller cannot be responsible for the interpretation of this information, nor can it assume any liability in connection with its use.

WARNING

To avoid personal injury, disconnect power before servicing this product. If electrical power is required for diagnosis or test purposes, disconnect the power immediately after performing the necessary checks.

RECONNECT ALL GROUNDING DEVICES

If grounding wires, screws, straps, clips, nuts, or washers used to complete a path to ground are removed for service, they must be returned to their original position & properly fastened.

Main Electronic Board

Caution: When servicing or testing in the main board area, many components and connections are electrically hot to ground. Be sure to use proper service procedures and protective devices.

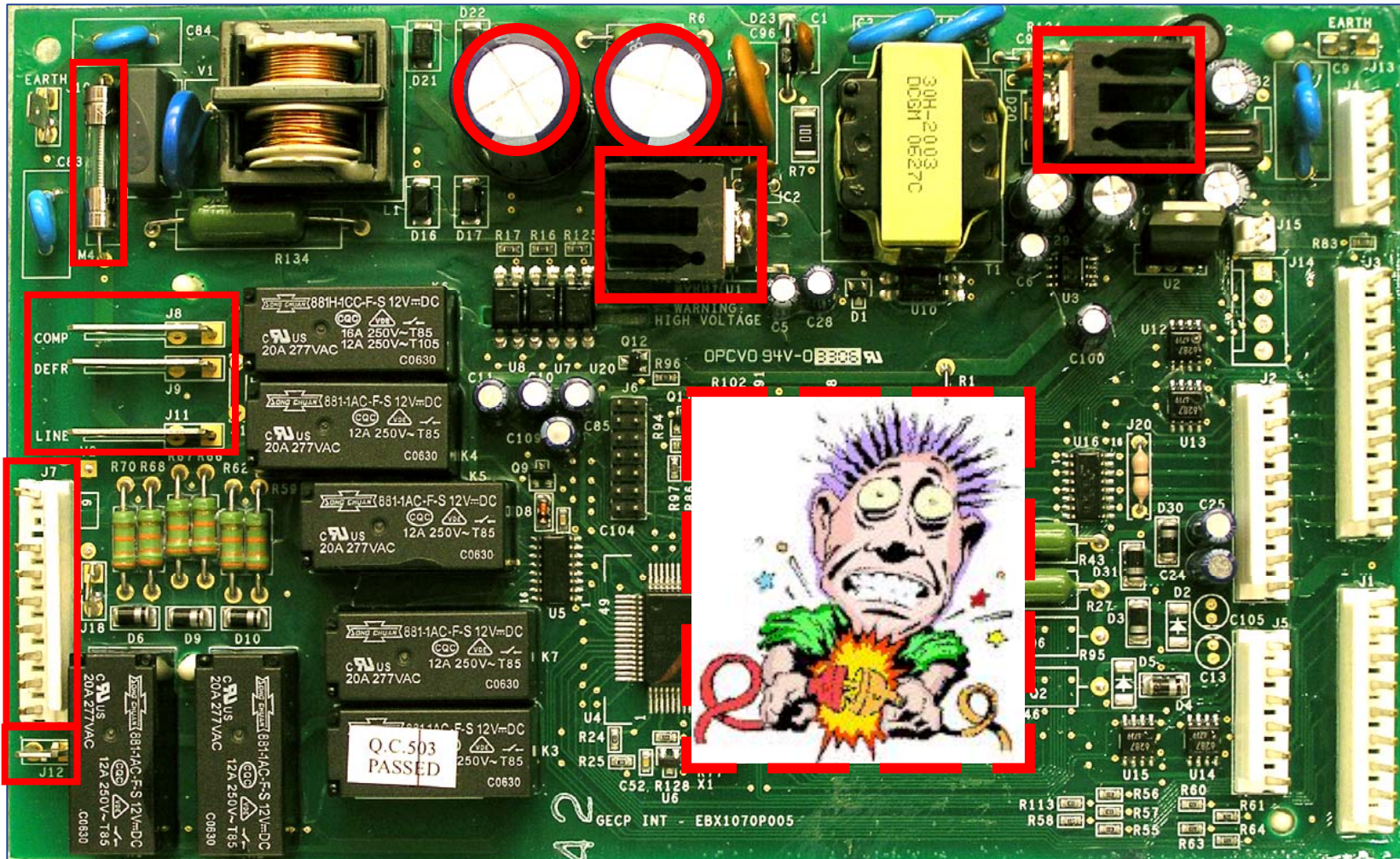

Electronic Diagnostic Test Mode

All the GE electronic refrigerators have a Diagnostic Mode that is incorporated in the software in each main electronic board. This Diagnostic Mode will test certain components and operate others.

To activate this diagnostic test feature on an electronic refrigerator, you will need a touch pad control with at least 5 key pads; otherwise you will have to install the additional diagnostic tool.

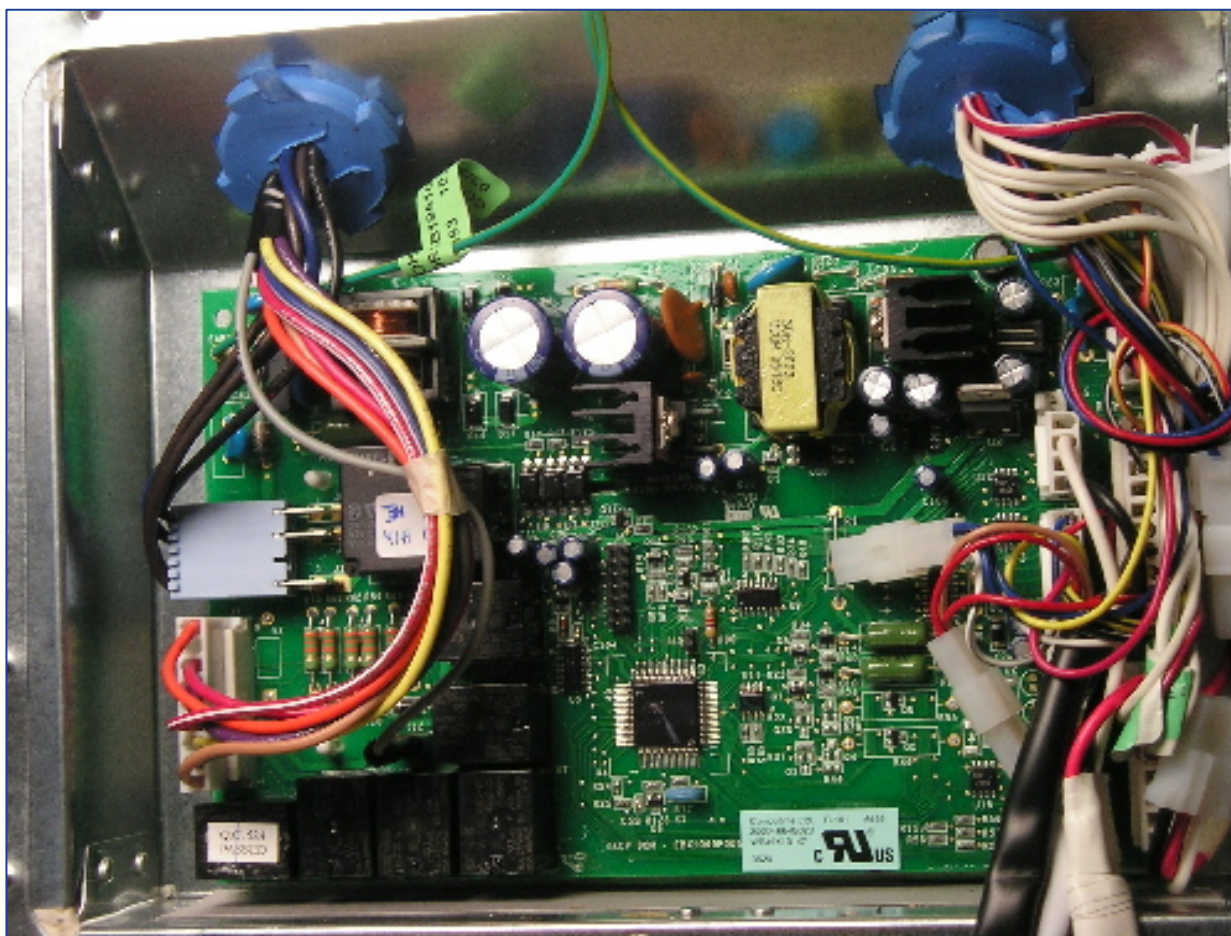

Diagnostics Aid Kit

The diagnostic aid kit may assist the technician to functionally test individual components.

A diagnostic aid kit can be assembled and consists of a key pad temperature control assembly and wire harness. The parts required are WR55X10390 and WX05X14999.

Using the kit, diagnostics can be performed by removing the base grill and plugging into the diagnostic aid wire harness located on the left side. Diagnostics can also be performed by accessing the main board on the back of the refrigerator and plugging into the harness extended from the board.

Note: After plugging in the diagnostic aid kit, if the display is blank, press and release any of the temperature pads. The display will show actual temperatures.

Diagnostic Aid - Front Access



Diagnostic Aid - Main Board Access

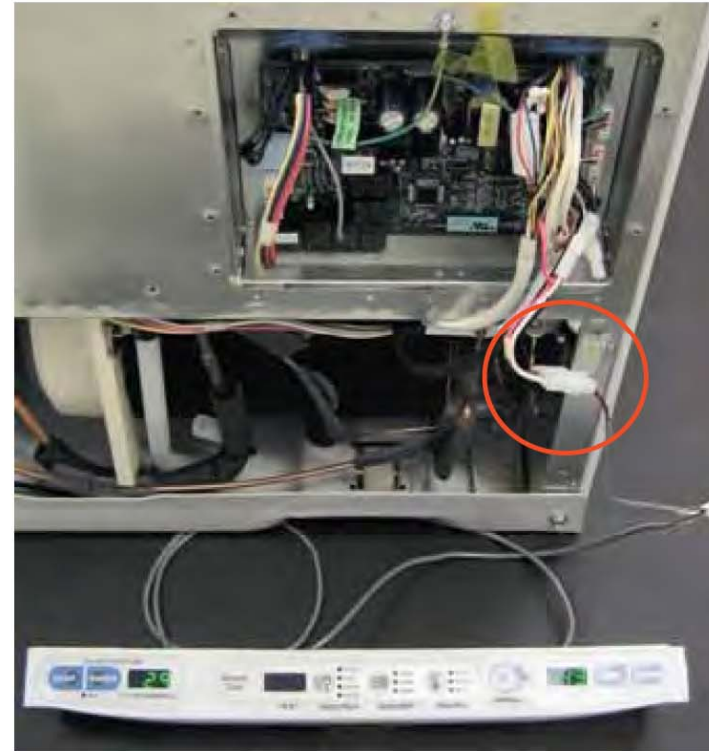

Electronic Diagnostic Test Mode

Control Diagnostics

Enter the diagnostic mode by pressing both the freezer temperature (COLDER and WARMER) pads and the refrigerator temperature (COLDER and WARMER) pads simultaneously. All four pads must be held for approximately 3 seconds. Blinking "0"s in both displays indicate the refrigerator has entered the test mode.

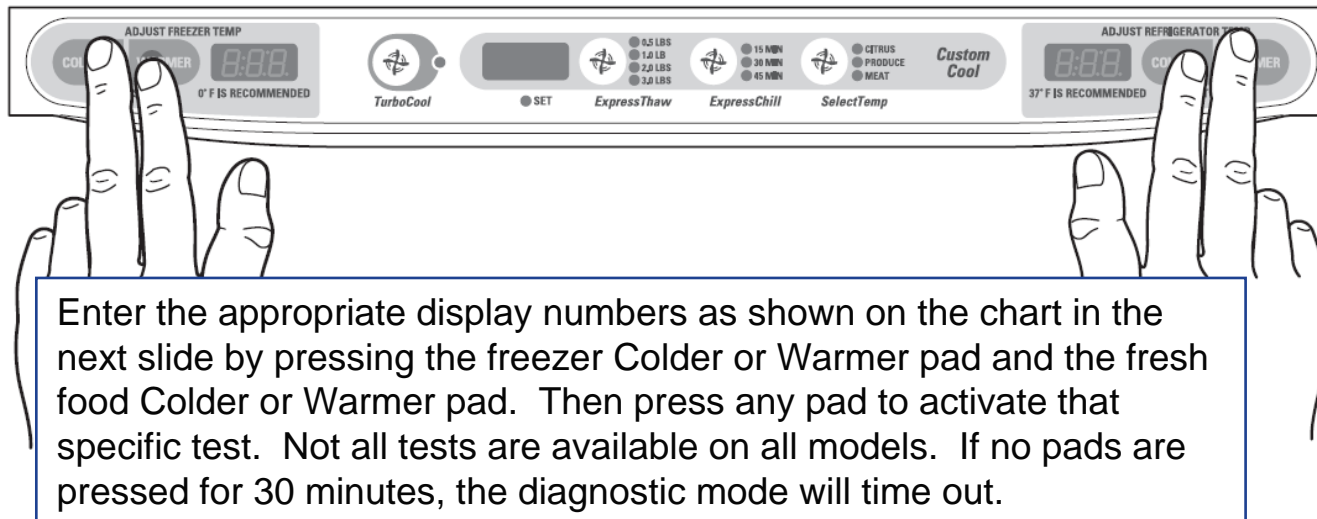

Electronic Diagnostic Test Mode

| Freezer Display | Fresh Food Display | Diagnostics | Results | Comments |
|-----------------|--------------------|--------------------------------|--|--|
| 0 | 7 | Control and Sensor System Test | Checks each thermistor in order. | See Note 1. |
| 1 | 0 | Dampers Test | Custom Cool™ damper will open, close after 10 seconds, pause briefly, then single damper will open for 10 seconds. | Test will not start for approximately 20 seconds after pad is depressed. |
| 1 | 1 | Fan Test | Cycles through each fan for 5 seconds. | |
| 1 | 2 | 100% Run Time | Sealed system on 100% of the time. Times out after 1 hour. | |
| 1 | 4 | Defrost Test | Toggles on the defrost cycle. See Note 2. | Must press again to turn heater off. See Note 2. |
| 1 | 5 | Main Control Reset/Test Exit | Causes a system reset and exits test mode. | |

This test will not indicate failure for thermistors out of spec

This test will also cycle the FF damper on single evap models

This test will attempt to turn ON the compressor if it is OFF

Note 1: Display order is #1 = Fresh Food Evaporator Thermistor, #2 = Fresh Food Thermistor, #3 = CustomCool™ Thermistor, #4 = Freezer Evaporator Thermistor, #5 = Freezer Thermistor.

Thermistor test results are: P = Pass, 0 = Fail, S = Short to 5 VDC, B = Defective board (replace main control).

Note 2: You **must** enter the defrost test again to toggle the defrost heater off at the end of the test. The heater will not come on if the evaporator thermistor is above 70°F (21°C).

Main Electronic Board

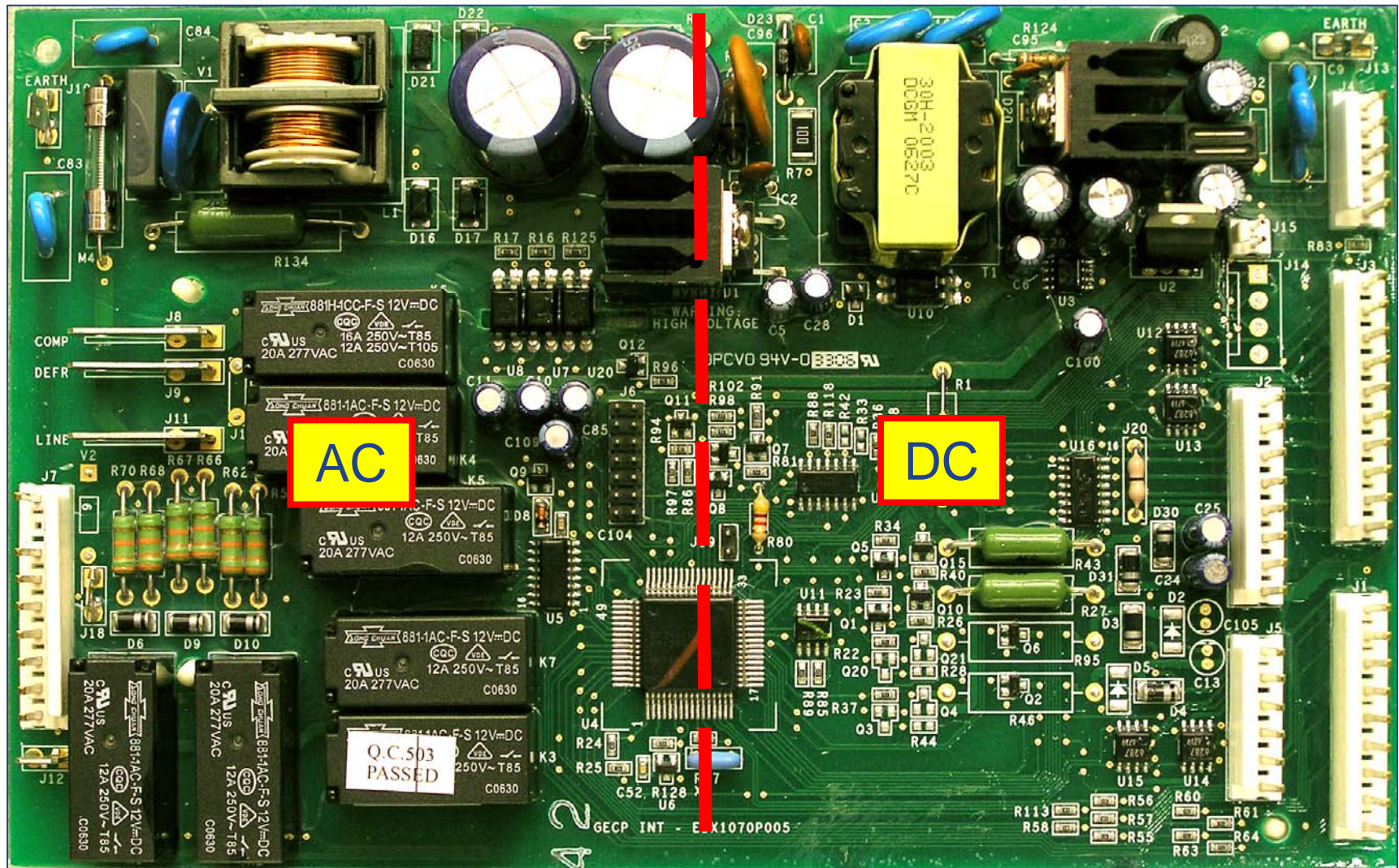

The main board outputs both AC and DC voltages to the refrigerator components. The one half of the board is AC inputs and outputs; while the other half of the board is DC inputs and outputs.

Note: Wiring connectors are not shown for a better view of the board.

Main Electronic Board

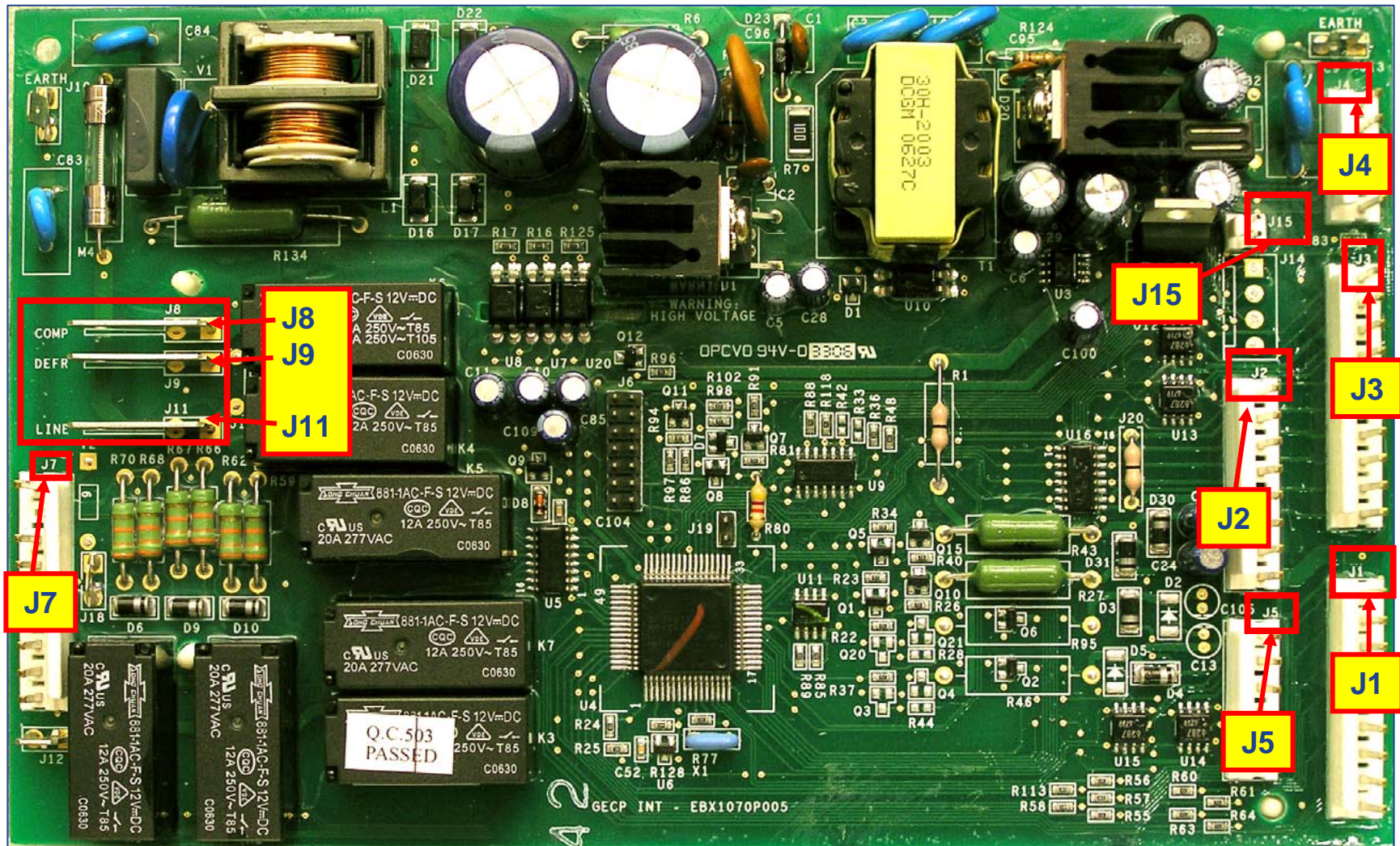

All "J" connectors are labeled on the main board, check the schematic for each model; since there may be some differences depending on the model.

Main Electronic Board

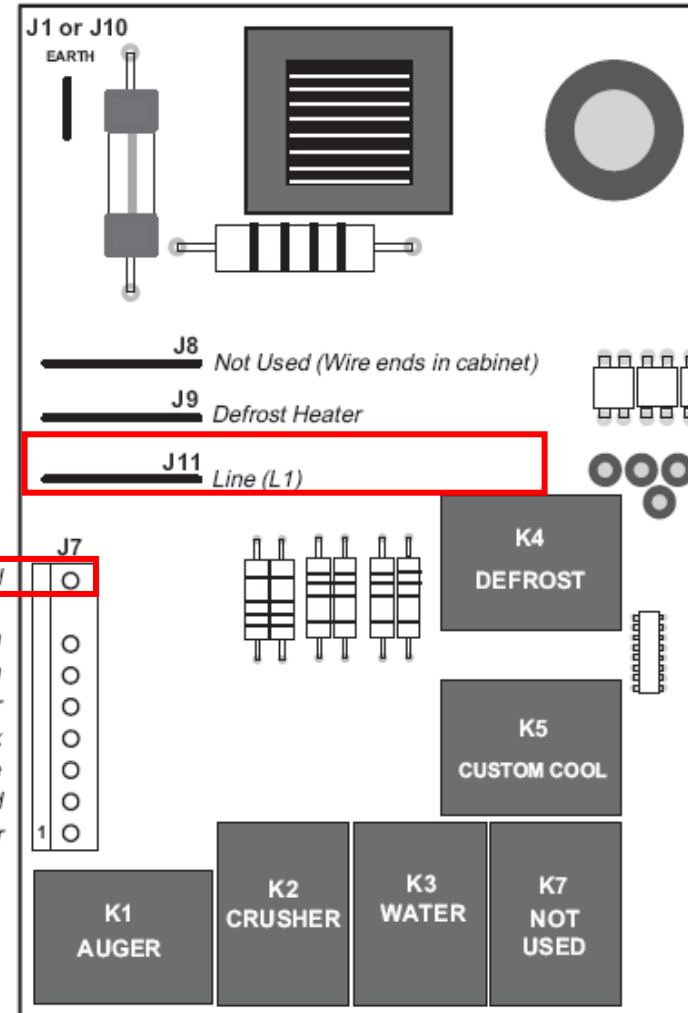
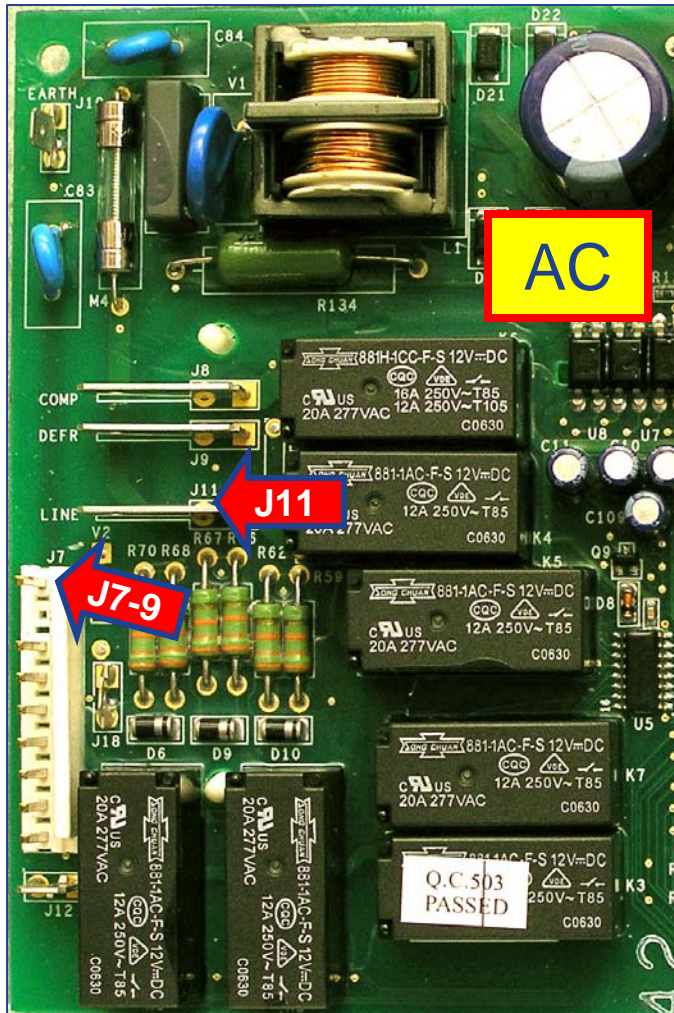

The main board is supplied with 120vac power between the J11 (L1) and J7 pin 9 (N) circuit.
 All the other 120vac components can be measured from the J7 connector.

Main Electronic Board Testing DC Output

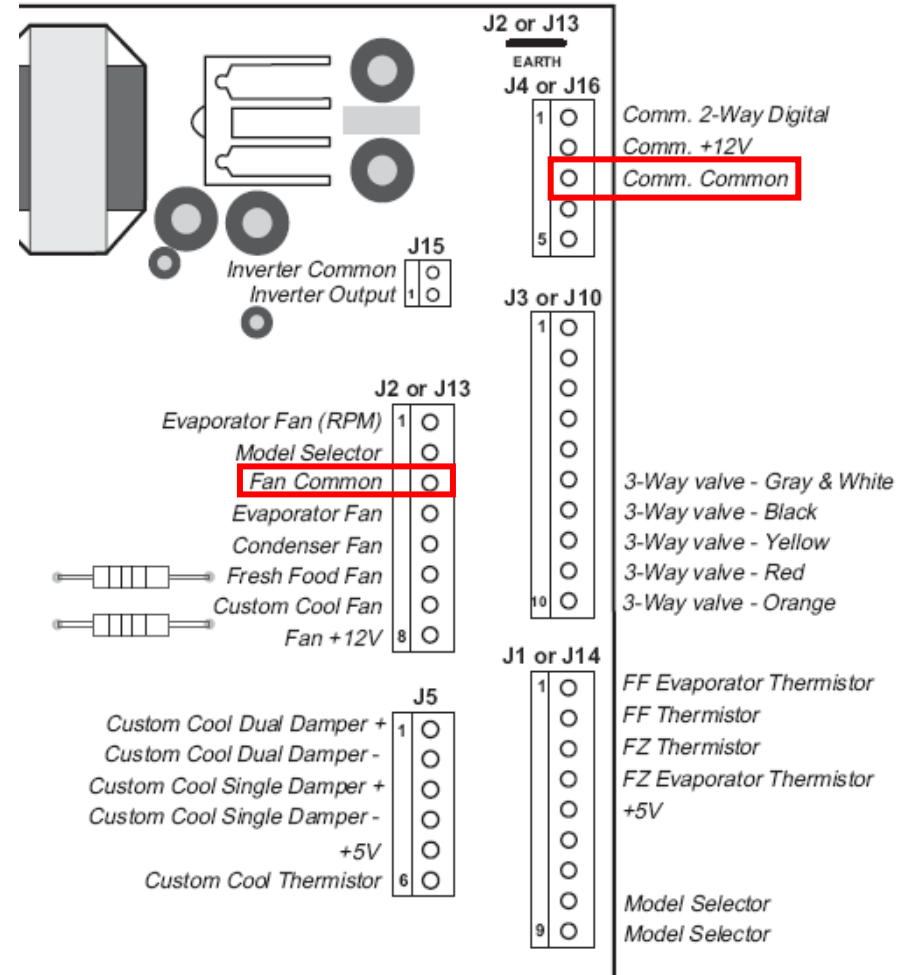
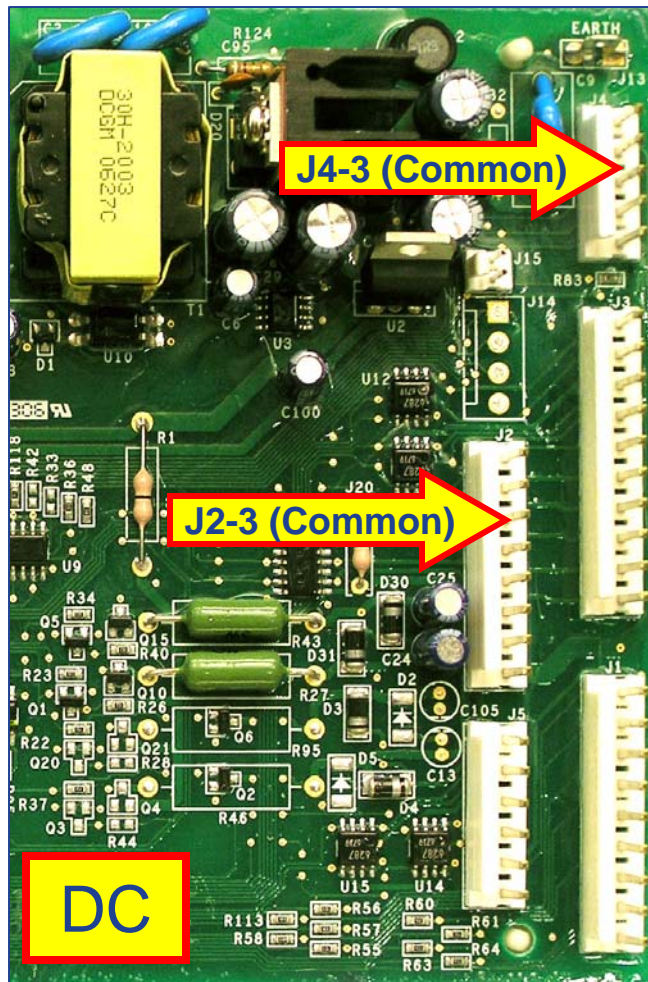

For DC voltage measurement, you will need to read between a DC common connection and the connection for the specific DC component you are checking. DC commons can be found at either J2 pin 3 or J4 pin 3. Checking J4-2 to J4-3 verifies the main board 12-13vdc output voltage.

Main Electronic Board

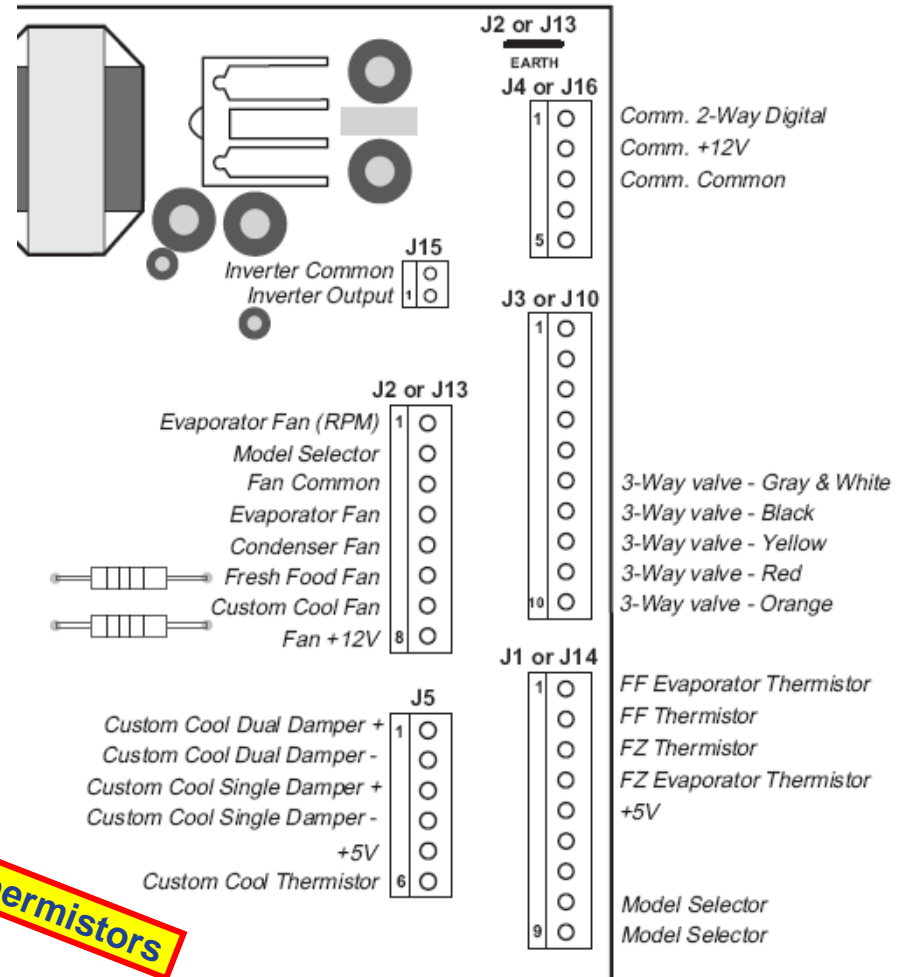
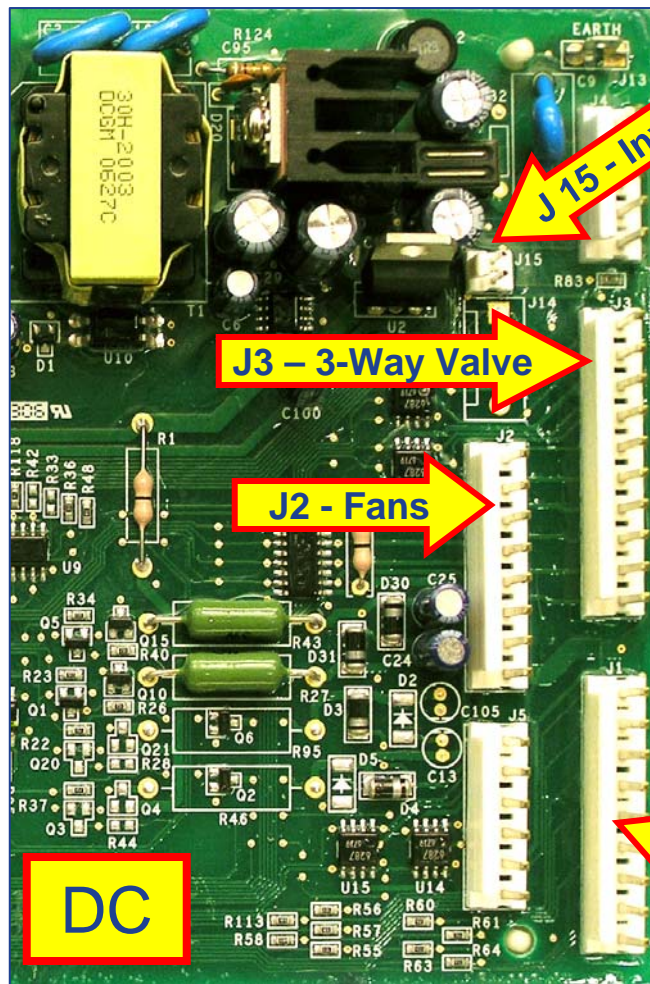

- Each DC component is connected at various plugs on the DC side of the board and operate on different DC voltages.
- J1 for Thermistors, J2 for fans, J3 for the 3-Way Valve, and J15 for the inverter models.
- Remember to measure a DC voltage, you must measure from one of the DC common points: J2 pin 3 or J4 pin 3.

Component problems?

The main board provides power to the components.

If the component is not running, it could be:

- The main board is not supplying power.
- To verify this, measure the output voltage with your volt meter.
- If there's no individual output voltage, the problem is at the board.
- But if you have voltage, verify the connections. A bad connection will prevent the component from receiving power.
- Verify the component itself. If it's receiving power and doesn't run, the component is the problem.

When using the Diagnostics Mode to verify the component's operation:

- Measure output voltage. This is the ultimate confirmation to locate the problem.
- Unless otherwise stated; voltage tests should be done with the load connected.

The diagnostics in this module cover individual AC components and their testing. If none of the components are operating – check the AC input to the board and the DC outputs. A shorted DC component can take down the main board.

Main Electronic Board

- The main board receives **Inputs** from various operations and makes decisions based on those inputs.
- The main board initiates **Outputs (commands)** by opening or closing relays on the board.
- The main board does NOT receive **AC feedback** to determine whether the **commands** were followed.
- As an example, the board will close the compressor relay for cooling, but the board does not know whether the compressor started running.
- The main board will retain the input data if there is a power failure.

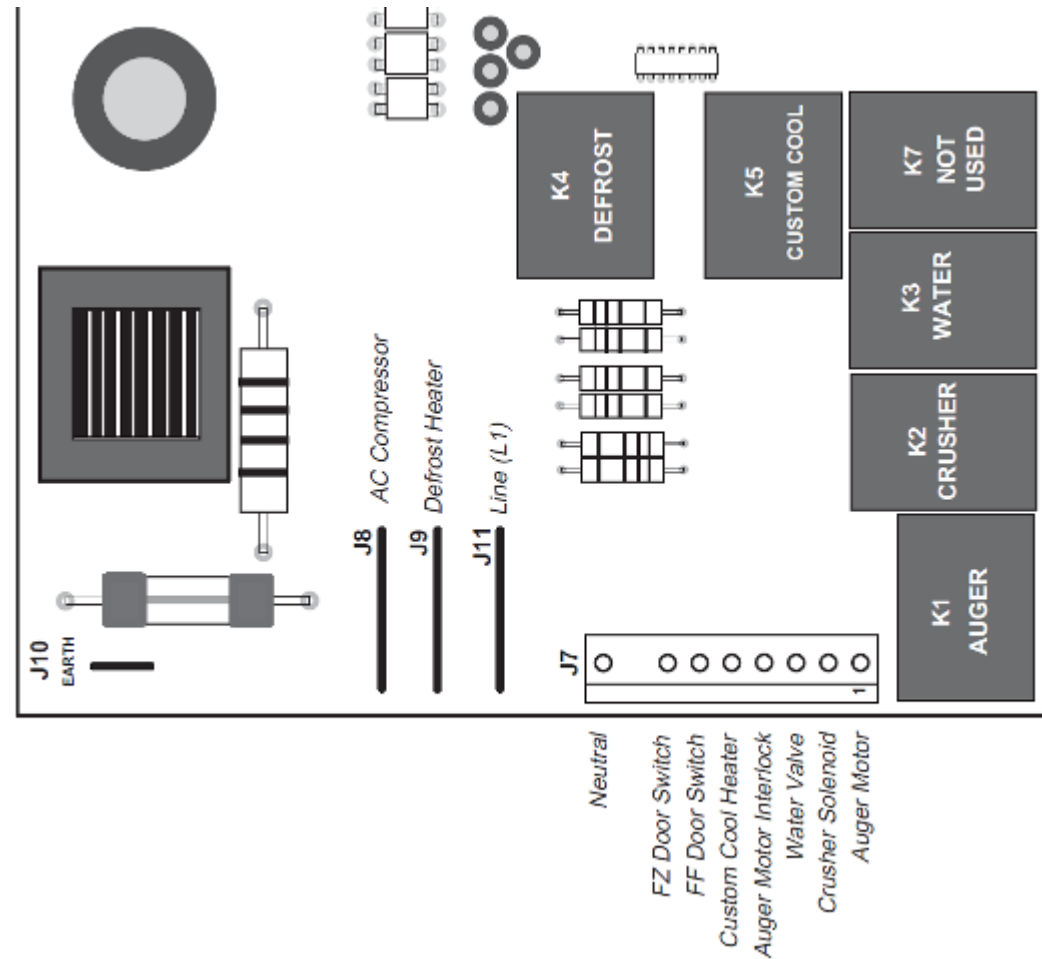

Main Electronic Board

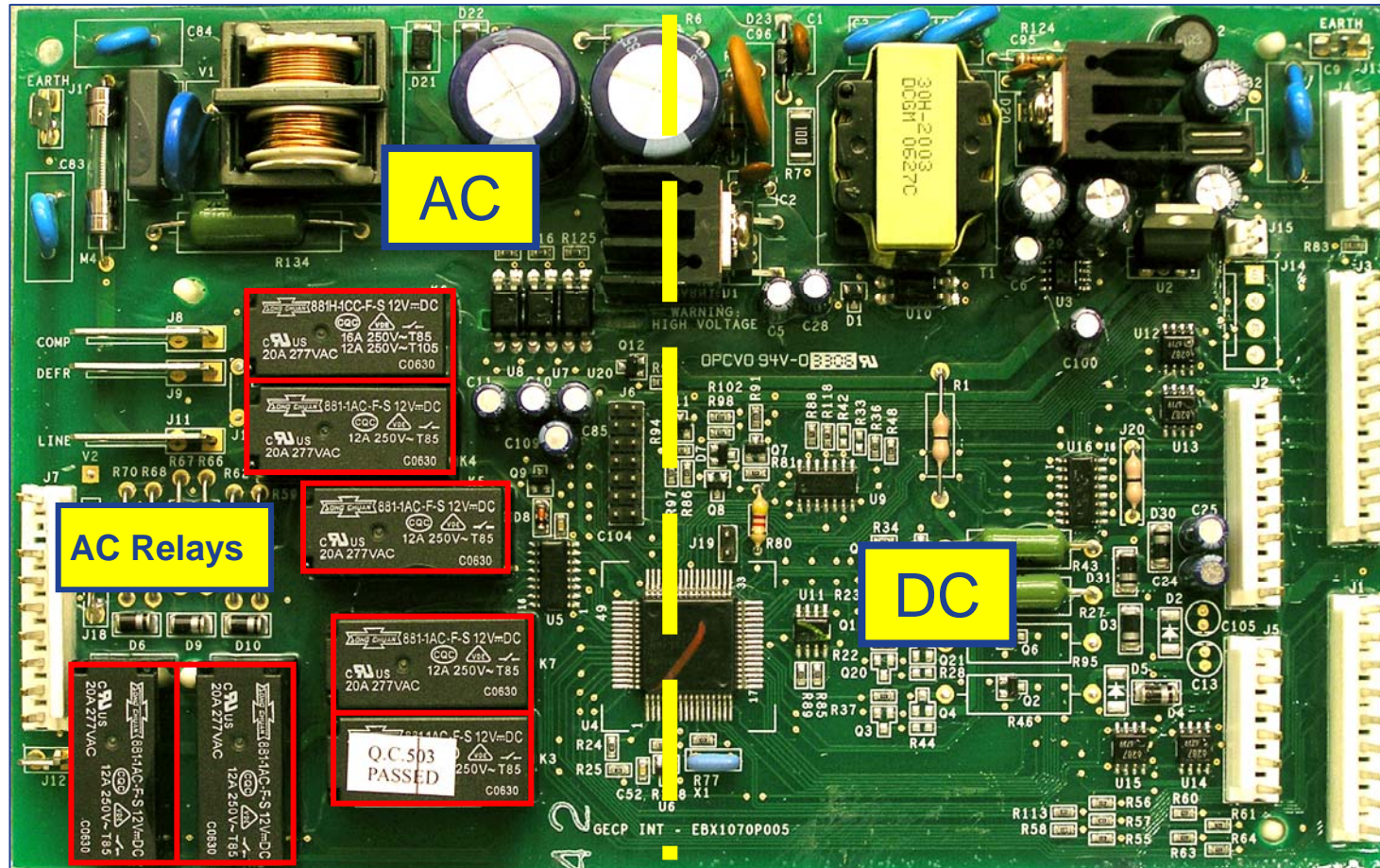

- The main board outputs both AC and DC voltages to the refrigerator components. One half of the board is for DC inputs and outputs; while the other half of the board is for AC inputs and outputs.
- The black “boxes” in the above picture are relays that the board uses to control the AC components (compressor, defrost heater, dispenser, water valve, etc.)

Main Electronic Board

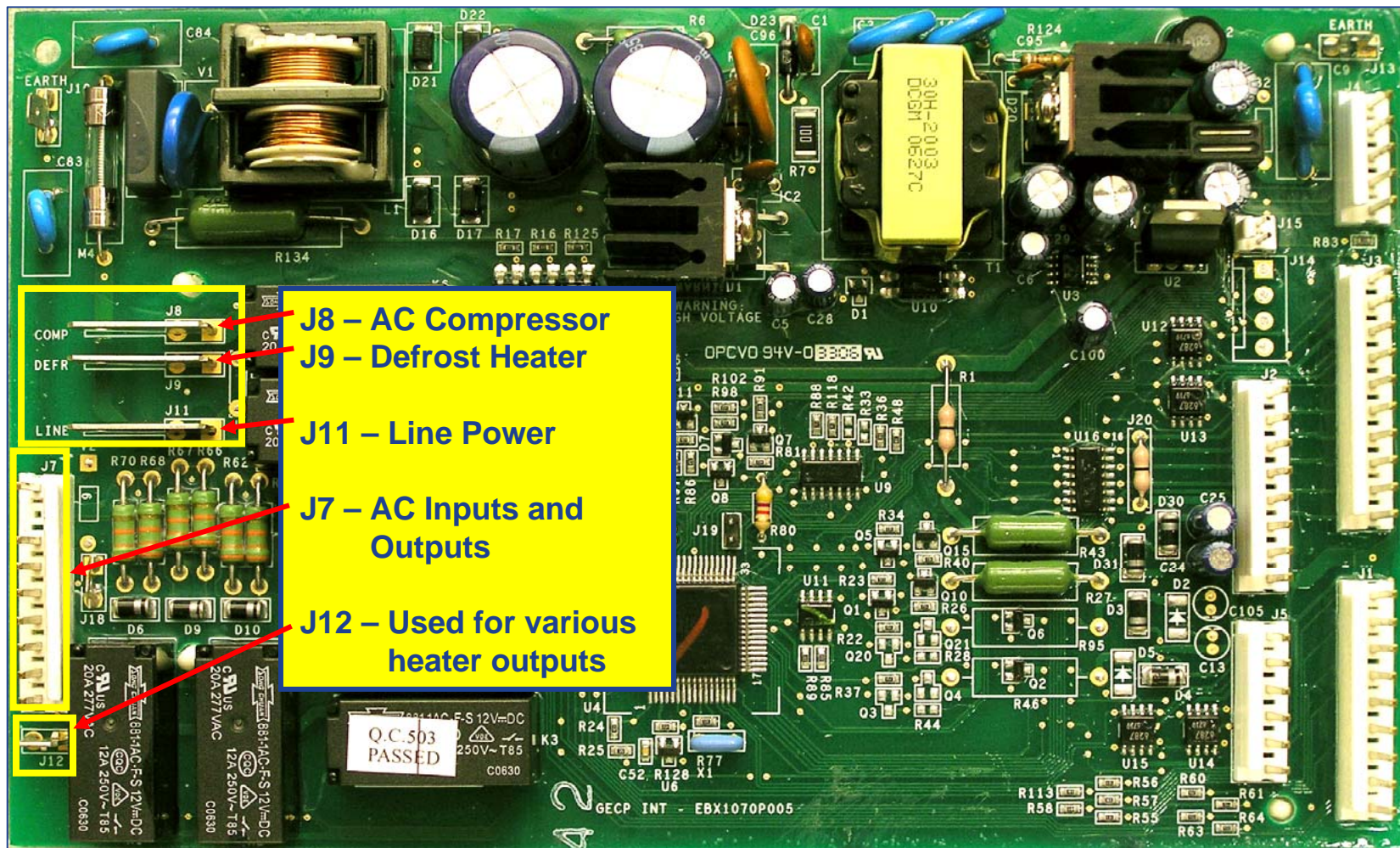

All “J” connectors are labeled on the main board, check the schematic for each model; since there may be some differences depending on the model.

Main Electronic Board

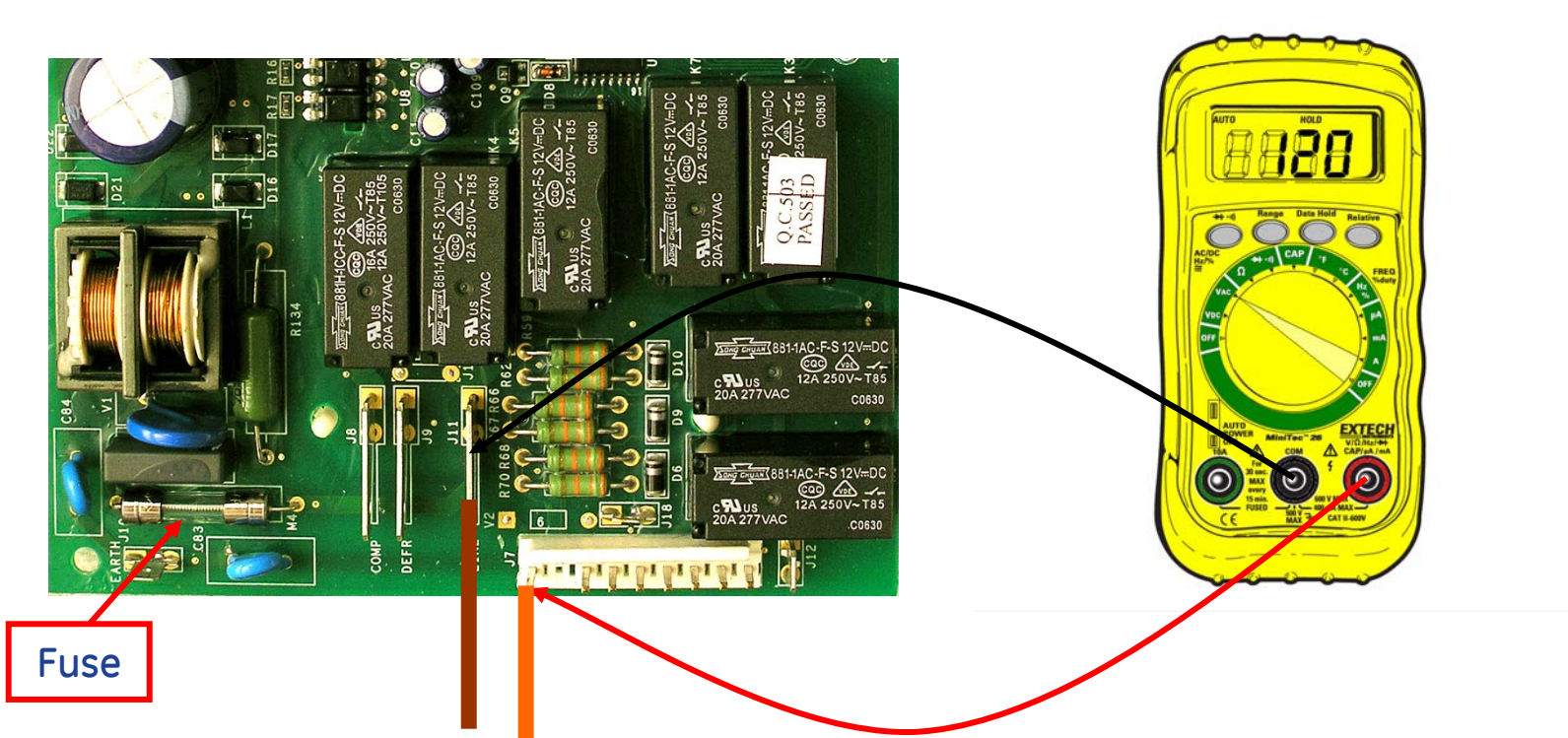

- The main board is supplied with 120vac in order for the main board to function. If the unit is dead you can measure the incoming AC power between the J11 **brown (L1)** and J7 pin 9 **orange (N)** circuit.
- If the fuse on the main board is open; it most likely failed from a utility power surge or power supply short circuit on the main board; replace the main board.

Testing the AC Compressor Circuit

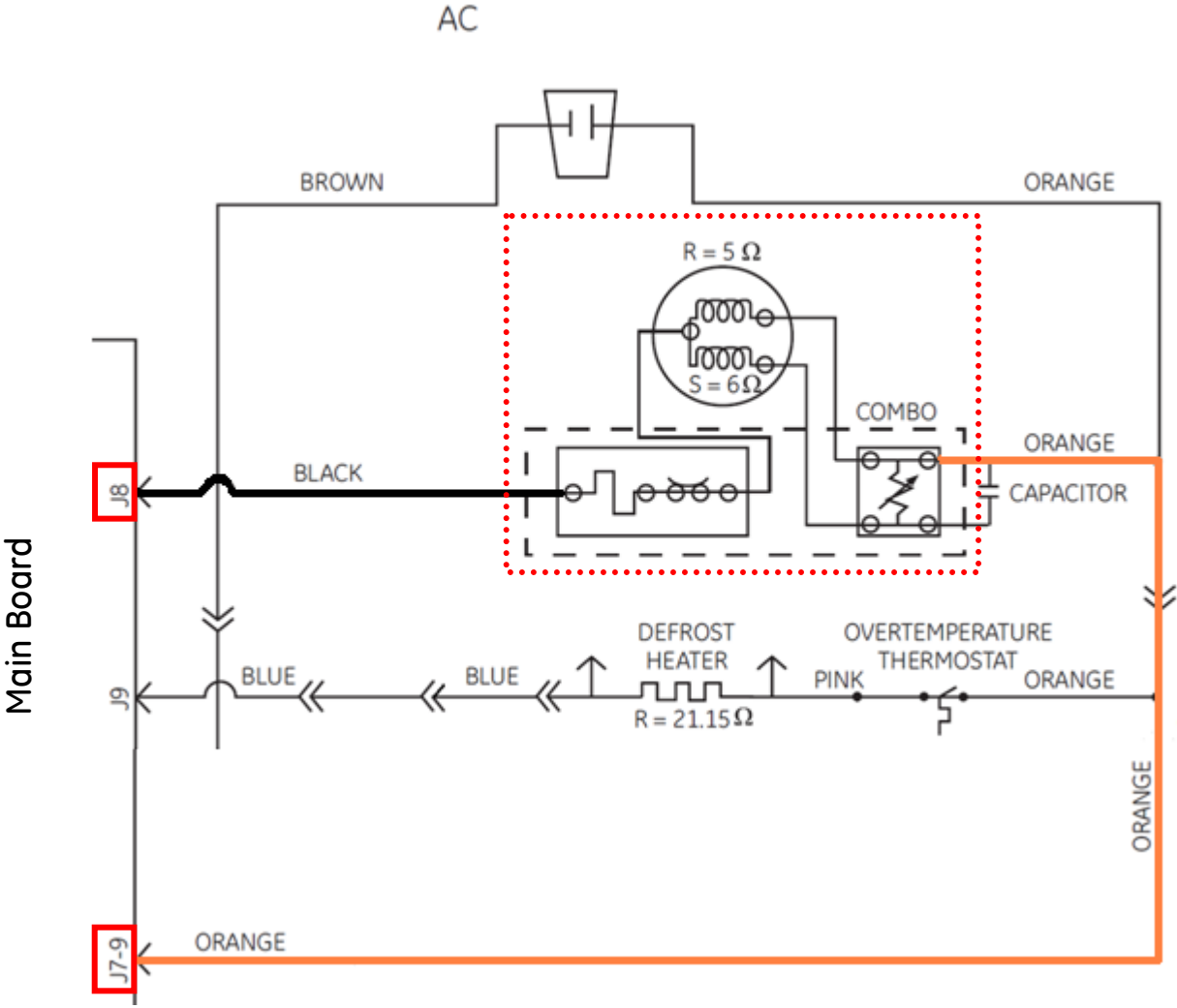

Testing the AC Compressor Circuit

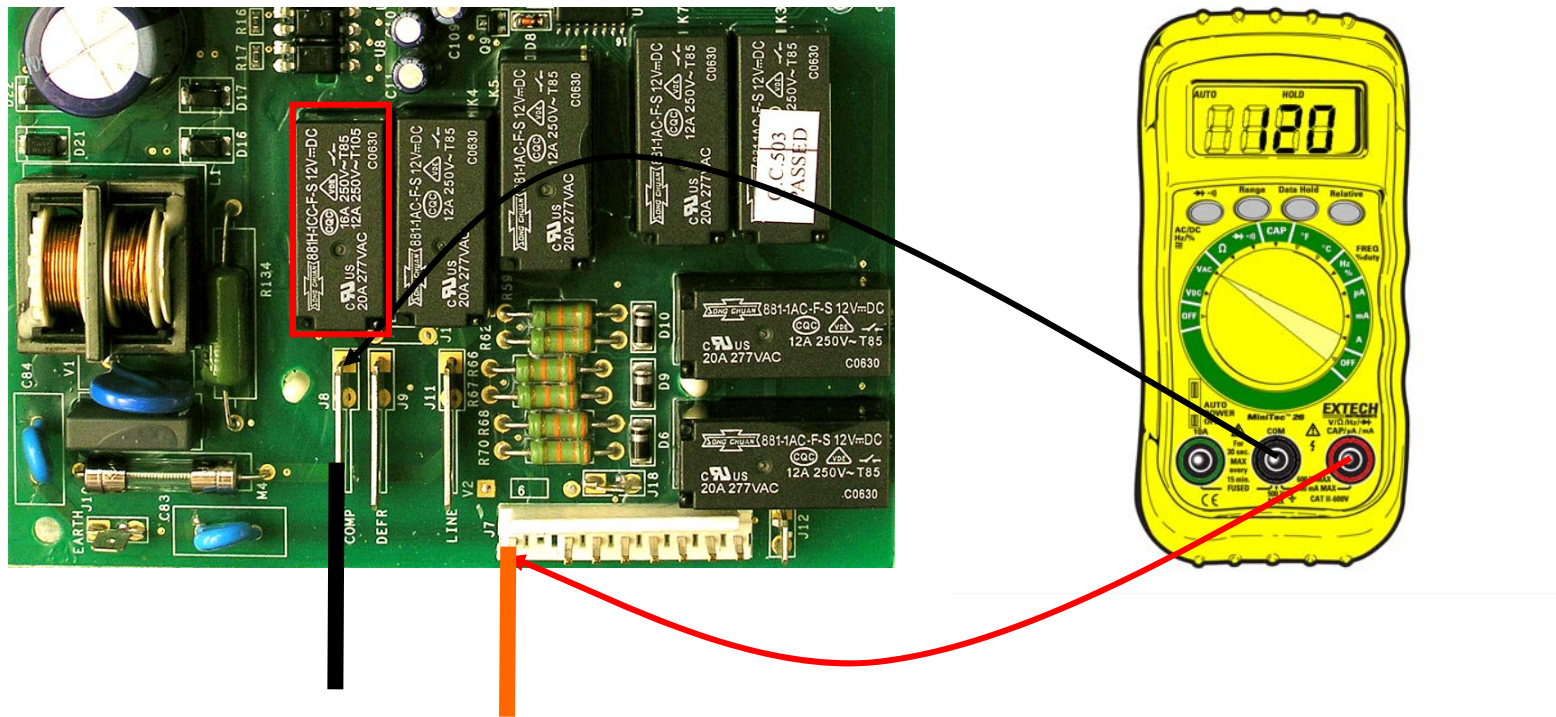

- If the compressor does not run (condenser fan on) - check for 120vac measured between J8 **black (Comp)** and J7 pin 9 **orange (N)**. Diagnostic mode code 1-2.
- If the voltage checks ok at this point the main board is not the fault; check the compressor and the cabinet wiring.
- If you hear the relay click and the run voltage is not present replace the main board.

Testing the AC Compressor Circuit

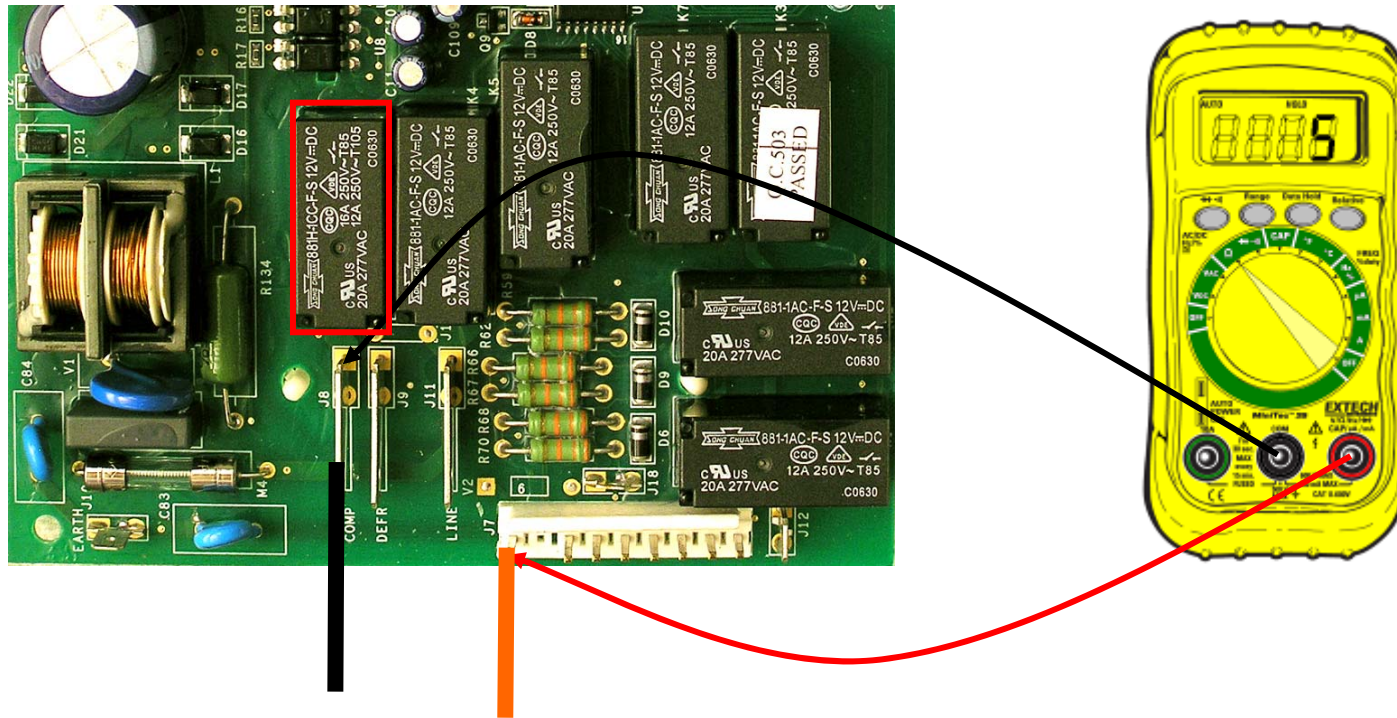

- If the compressor does not run, unplug the refrigerator and check for resistance between J8 **black** and J7 pin 9 **orange (N)**. Refer to the specific diagram for resistance value.
- If the circuit reads open at this point; check the compressor and the cabinet wiring.
- Check the J8 **black** wire to cabinet ground to check for a grounded compressor; which may have damaged the compressor relay on the main board.

Testing the AC Compressor Circuit

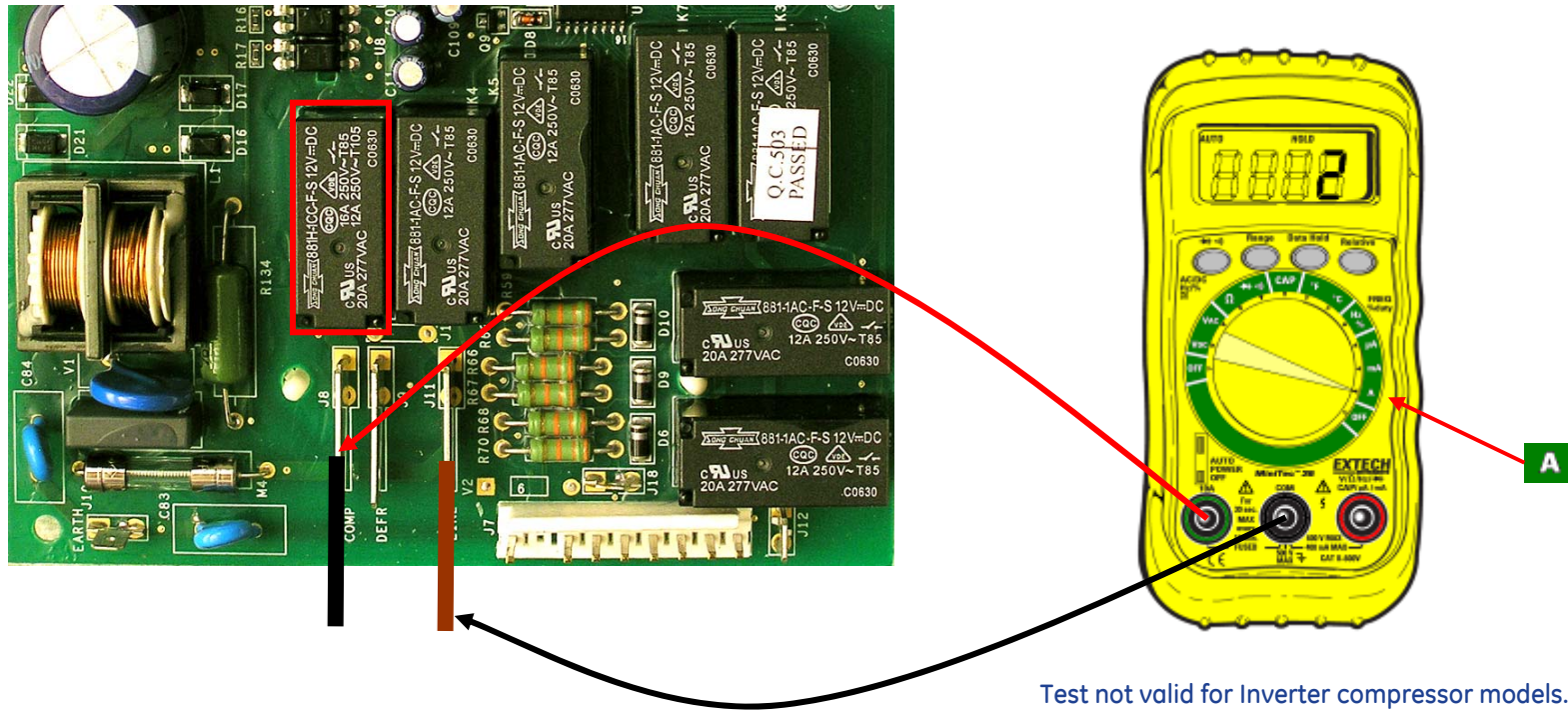

- If the compressor resistance between J8 **black** and J7 pin 9 **orange (N)** checks good and is not shorted to ground attempt to direct test the compressor.
- If your volt/ohm meter has an Ammeter function, set the meter for amps and check across the J8 **black** to the J11 **brown** to attempt to start the compressor by bypassing the main board. If the compressor runs, replace the main board.

Note: Be sure to set your meter back to AC volts if your going to perform further voltage tests.

Testing the AC Defrost Circuit

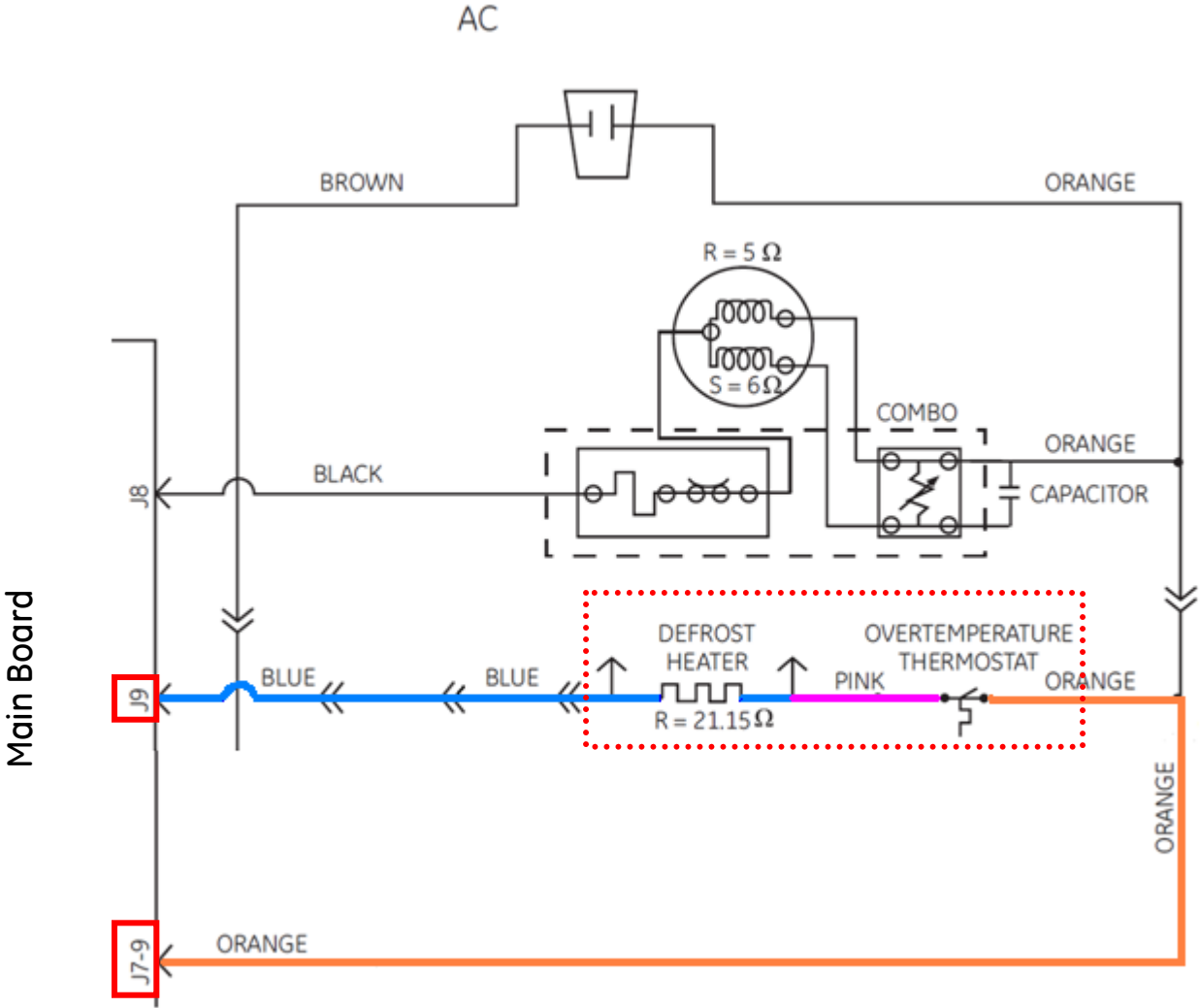

Testing the AC Defrost Heater Circuit

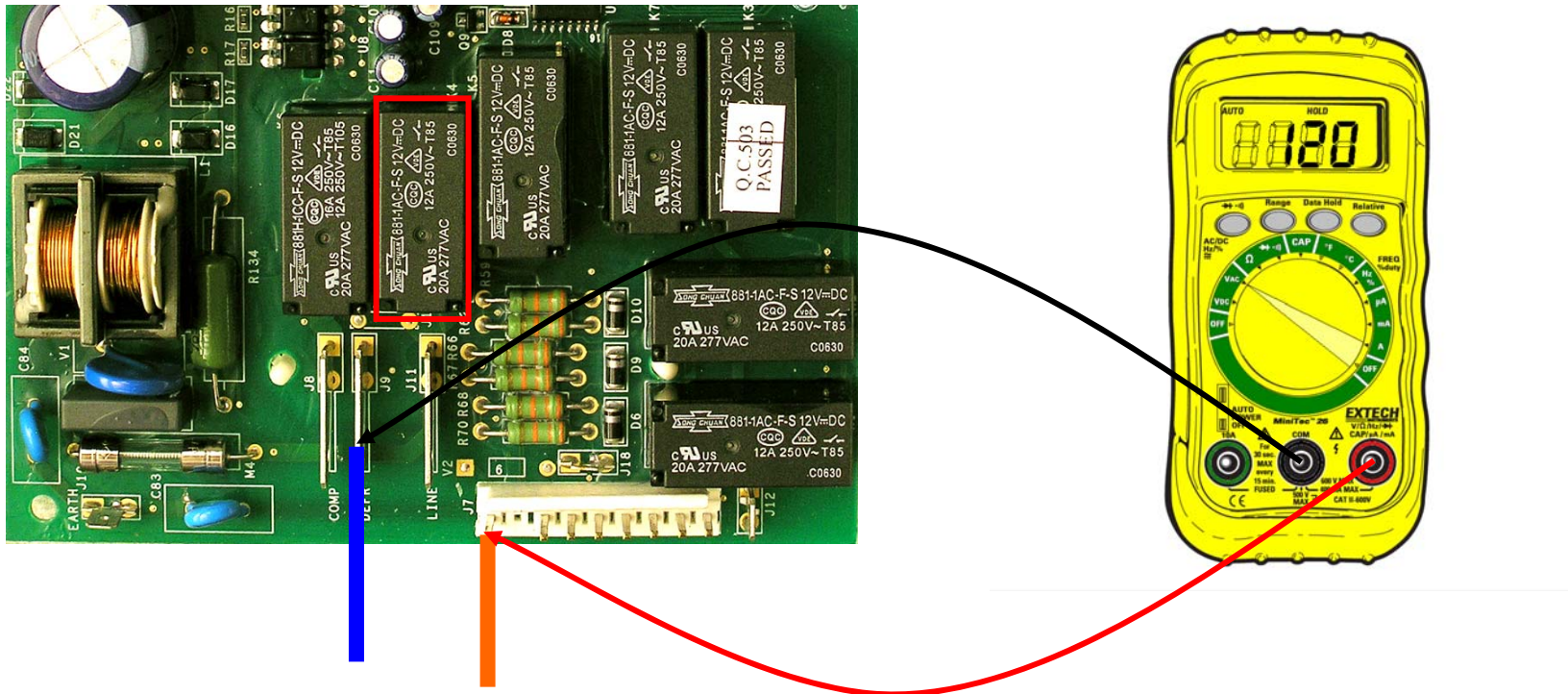

The defrost heater receives 120vac measured between **J9 blue** and **J7 orange** pin 9 (N). If you read 120vac in this test, check the defrost heater and safety thermostat circuit. Diagnostic mode 1-4.

You can also clamp an amp probe around the **J9 blue** wire to verify the heater is on and holding current.

Testing the AC Defrost Heater Circuit

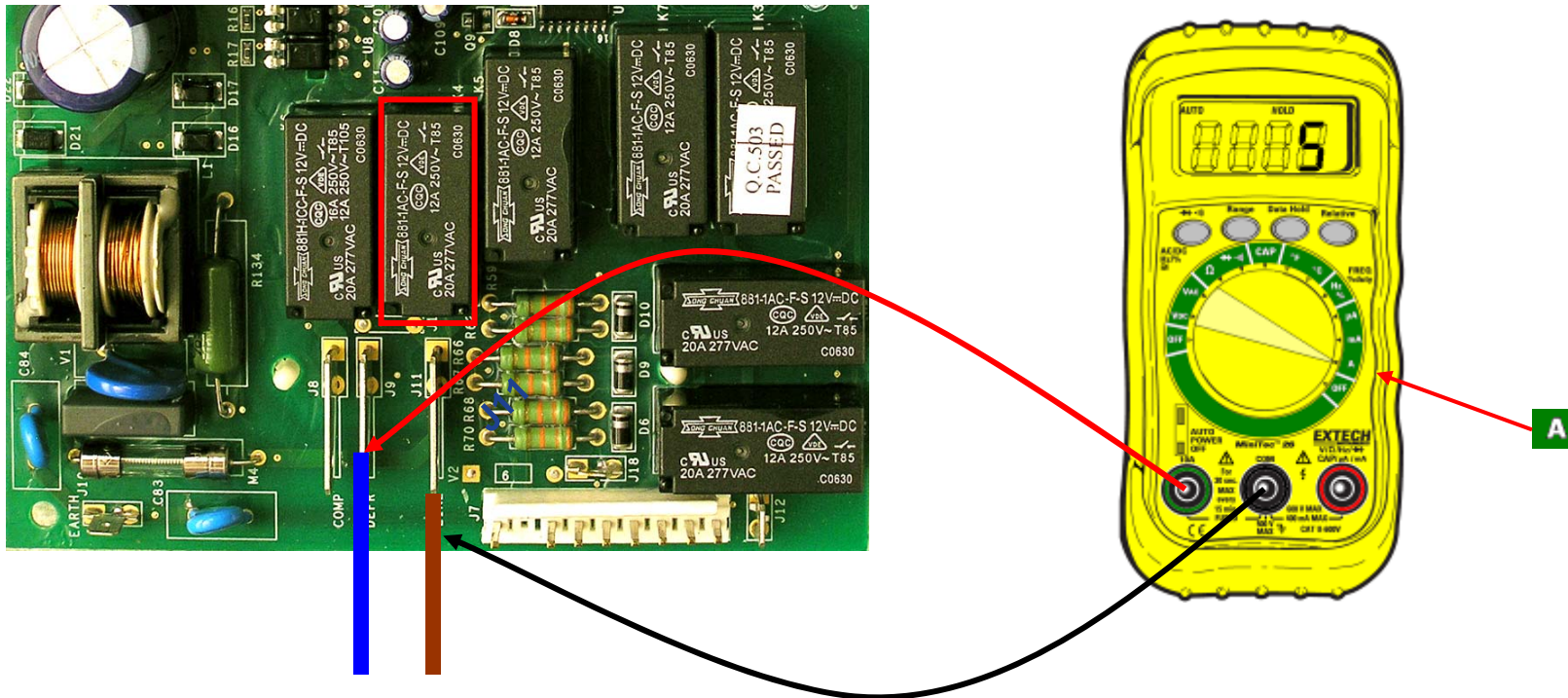

An alternate test without diagnostic mode would be to set your meter for amperage and test from **J9 blue** to the **J11 brown** line in. If the defrost heater comes on and holds current, replace the main board.

Note: Be sure to set your meter back to AC volts if your going to perform further voltage tests.

Another test would be to check resistance of the defrost circuit across **J9 blue** to the **J7 pin 9 orange** with the refrigerator disconnected from power. Refer to specific diagram for resistance value.

Testing the AC Dispenser Functions

The J7 connector on the main board uses inputs and outputs for the dispenser operation.

Door switch inputs to the main board are essential for correct dispenser operation.

There are two inputs for dispenser operation, J7-4 is for auger operation and J7-7 is used for water dispensing.

J7-1,2,3 are outputs to the individual components.

| CONTROL BOARD PIN DEFINITIONS | | | | |
|-------------------------------|-----|-------|--------|---|
| CONNECTOR | PIN | INPUT | OUTPUT | FUNCTION |
| J7 | 1 | | VAC | Switched L1 voltage to the auger motor - 120 VAC. |
| J7 | 2 | | VAC | Switched L1 voltage to the cube solenoid - 120 VAC. |
| J7 | 3 | | VAC | Switched L1 voltage to the water valve - 120 VAC. |
| J7 | 4 | VAC | | Receives L1 input from freezer door switch when freezer door is closed. |
| J7 | 5 | | VAC | Switched L1 voltage to the ExpressThaw (CustomCool™) heater - 120 VAC. |
| J7 | 6 | VAC | | Receives L1 input from fresh food door switch when door is open. This input is used for evaporator fan control, liner protection mode calculations, door alarm calculations, and adaptive defrost calculations. |
| J7 | 7 | VAC | | Receives L1 input from freezer door switch when door is open. This input is used for evaporator fan control, liner protection mode calculations, door alarm calculations, adaptive defrost calculations and some door interlock functions. Switch must be closed in door closed position (switch depressed) for dispenser LED light and duct door magnet to energize. |
| J7 | 9 | VAC | | AC neutral in. |

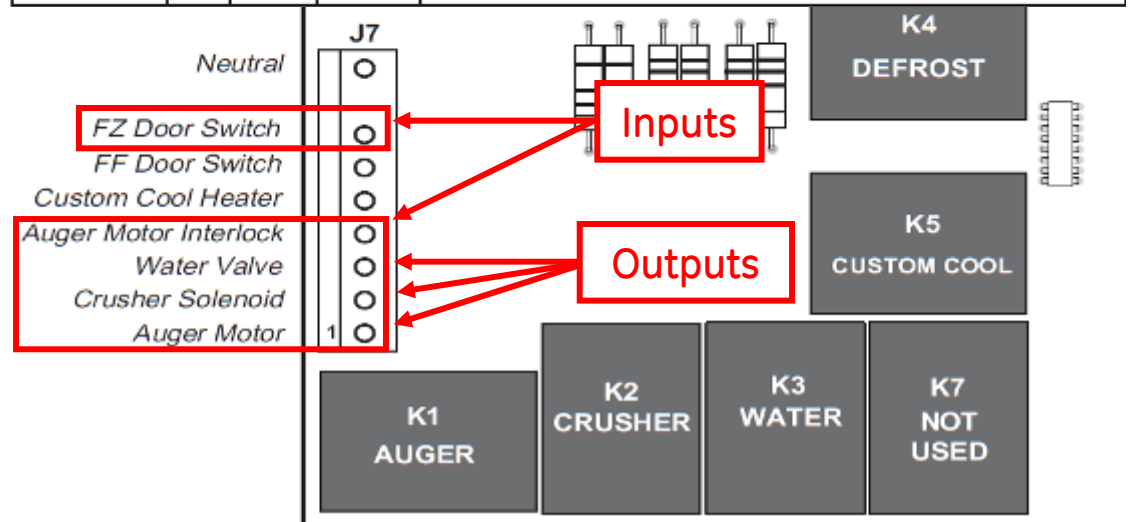

Testing the AC Ice Dispenser

In order for the auger motor and cube solenoid to operate; we have to have 120vac (input) coming back from the freezer door switch. **J7-4** receives power from the door switch when the door is closed and supplies that power to the auger and cube relays, "auger interlock."

If both the auger and cube solenoid fail to operate, check for 120vac from J7-4 to J7-9 to verify that the door switch has not failed or has a poor wiring connection.

| | | | |
|----|---|-----|---|
| J7 | 4 | VAC | Receives L1 input from freezer door switch when freezer door is closed. |
|----|---|-----|---|

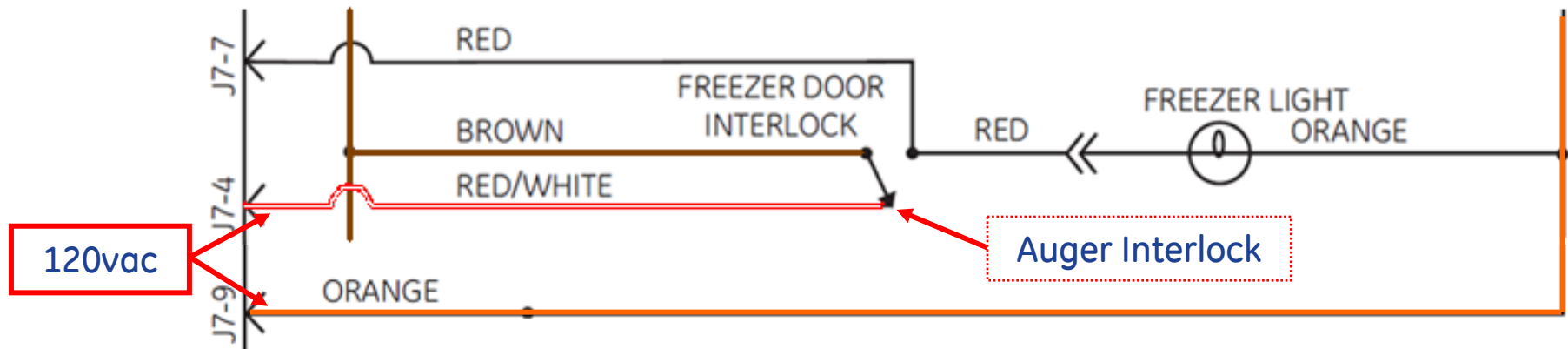

The water dispenser will still operate since the water relay does not use this interlock input.

Testing the AC Auger Relay

Operate the ice dispenser and check for 120vac on the J7-1 to the J7-9 terminals.

As with other AC components you can use your meter ammeter function and check from J11 line to the J7-1 to check the auger motor operation.

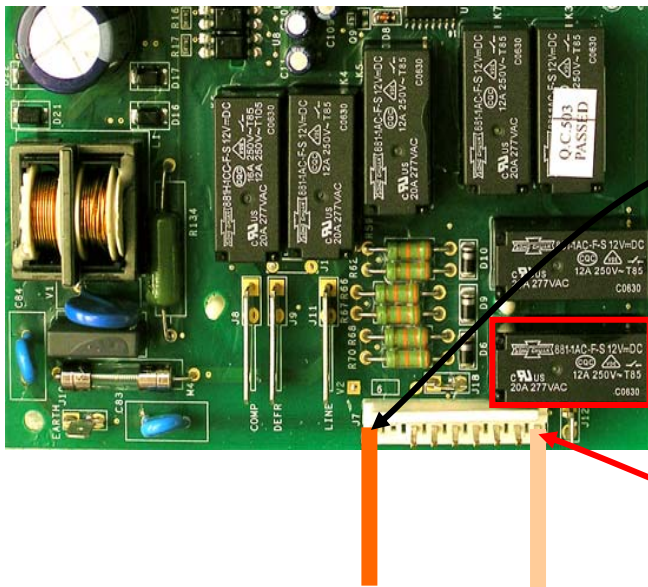

If you have output voltage from the board check the auger motor and associated wiring. If you don't hear the relay click or have the output voltage - replace the main board.

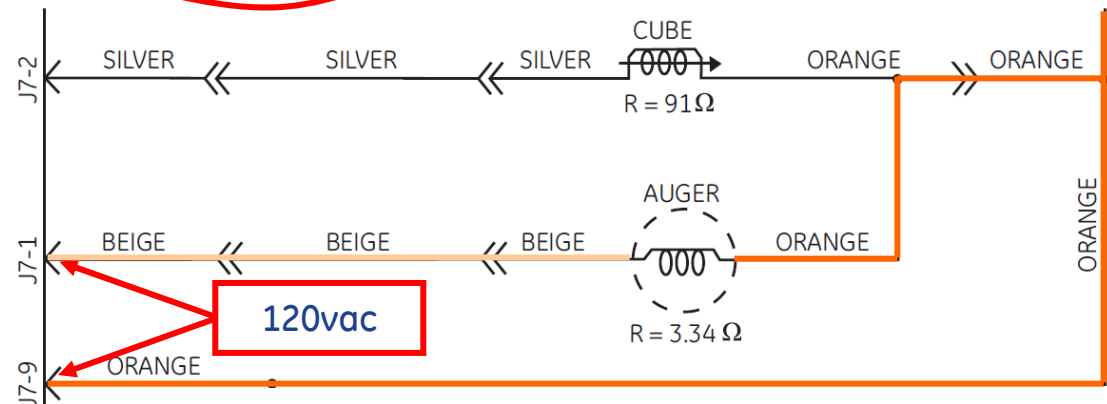

Wire colors can vary, check the schematic with the unit.

Testing the AC Cube Relay

Select "Cubed Ice" to activate the Cubed Ice Relay. Check for 120vac on the J7-2 to the J7-9 terminals.

As with other AC components you can use your meter ammeter function and check from J11 line to the J7-2 to check the solenoid operation.

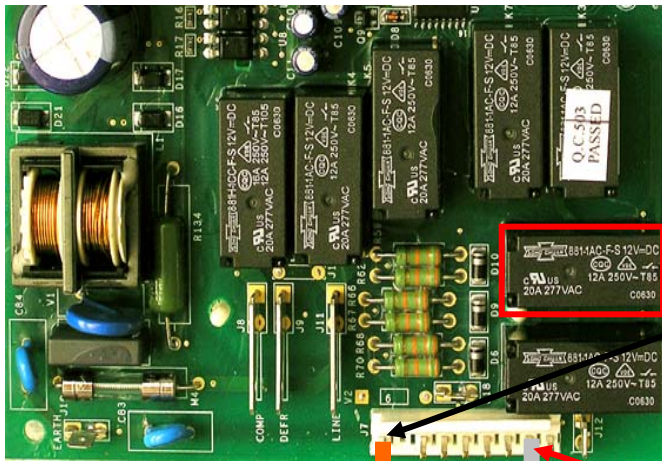

If you have output voltage from the board check the solenoid and associated wiring. If you don't hear the relay click or have the output voltage - replace the main board

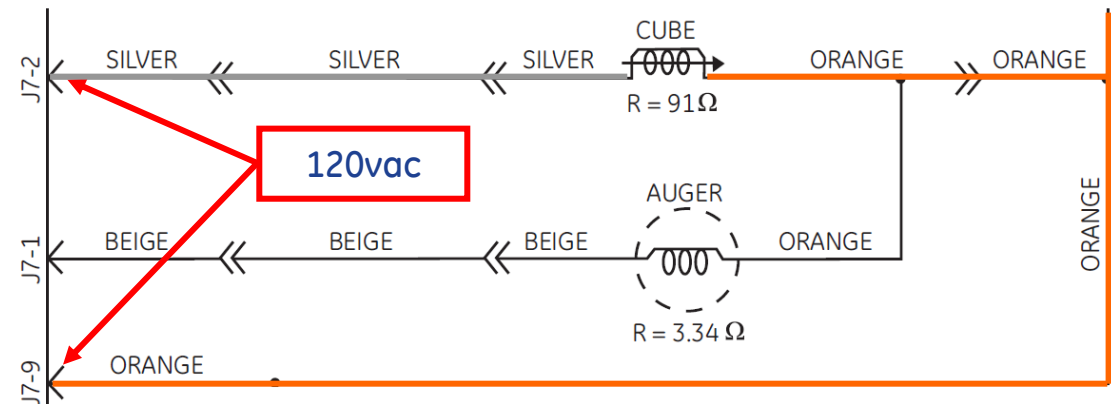

Wire colors can vary, check the schematic with the unit.

Testing the AC Water Dispenser

The dispenser water valve does not rely on the auger interlock to operate. The lack of voltage input to the J7-7 lets the board know that the door is closed. This is why the water dispenser can operate when the auger motor and cube solenoid do not. When the door is open 120vac is sent to J7-7 disabling the water feature.

| | | | |
|----|---|-----|--|
| J7 | 7 | VAC | <p>Receives L1 input from freezer door switch when door is open. This input is used for evaporator fan control, liner protection mode calculations, door alarm calculations, adaptive defrost calculations and some door interlock functions. Switch must be closed in door closed position (switch depressed) for dispenser LED light and duct door magnet to energize.</p> |
|----|---|-----|--|

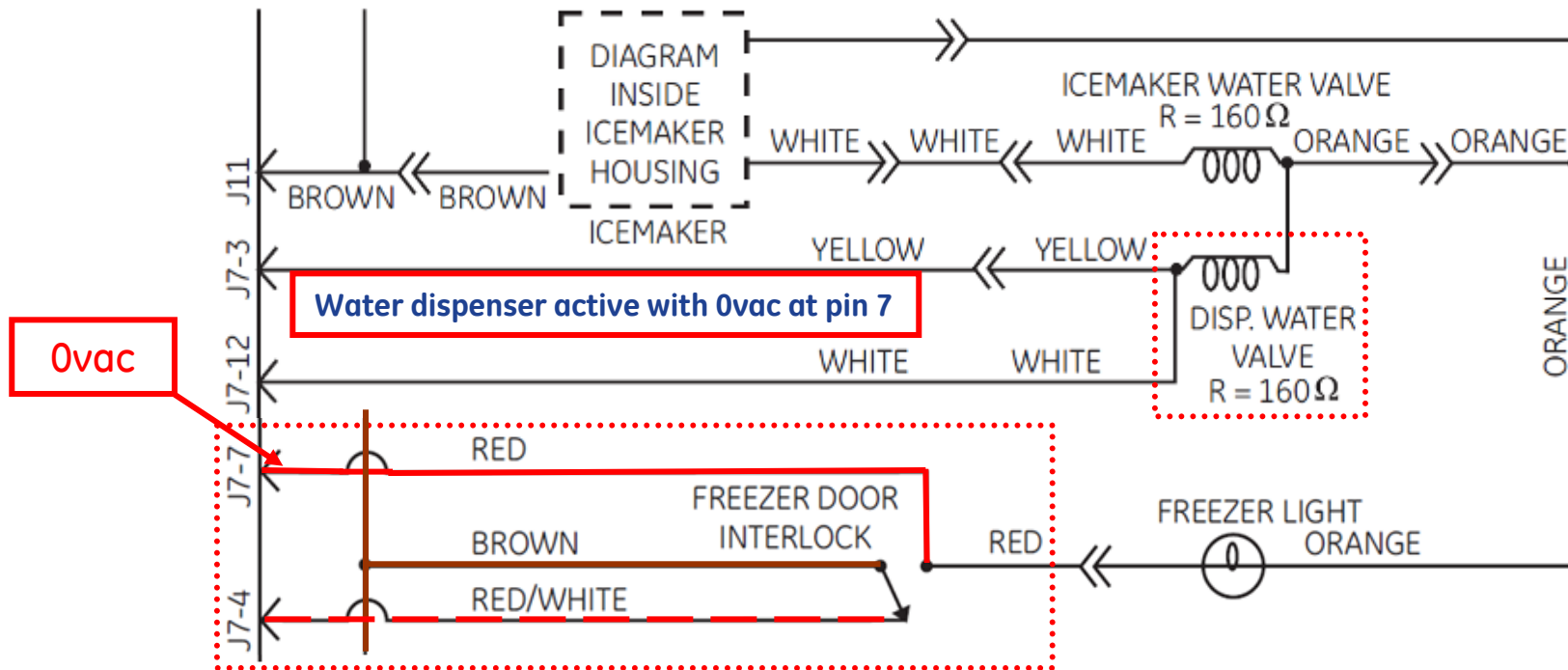

Testing the AC Water Dispenser

Select "Water" to activate the Water Relay. Check for 120vac on the J7-3 to the J7-9 terminals.

As with other AC components you can use your meter ammeter function and check from J11 line to the J7-3 to check the valve operation.

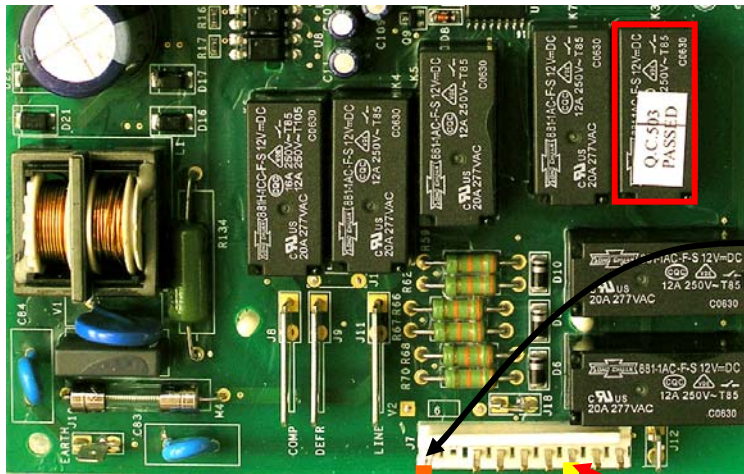

If you have output voltage from the board check the valve and associated wiring. If you don't hear the relay click or have the output voltage - replace the main board.

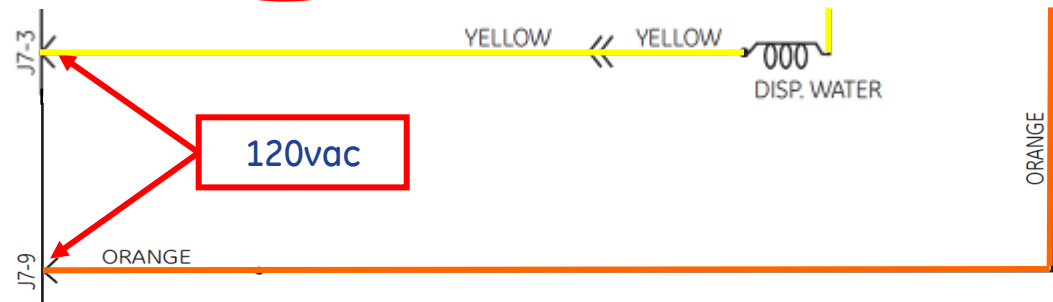

Testing the AC Custom Cool Drawer Heater

Some models have a climate controlled drawer in the bottom of the fresh food section. In order for this drawer to operate at higher temperatures than the fresh food temperature; a foil heater in the drawer is activated. You can turn this heater on by selecting Quick Thaw on the customer controls. You should hear the drawer fan turn on and the heater should be active.

When the heater is activated you should read 120vac from the J7-5 to J7-9.

You can also read the resistance of the heater on these same terminals with power disconnected and the connector off the board.

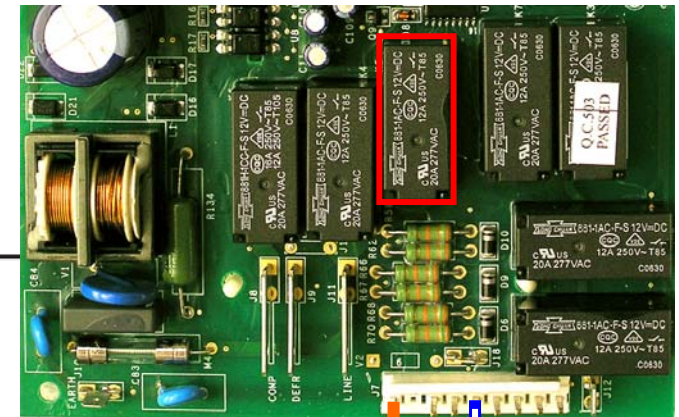
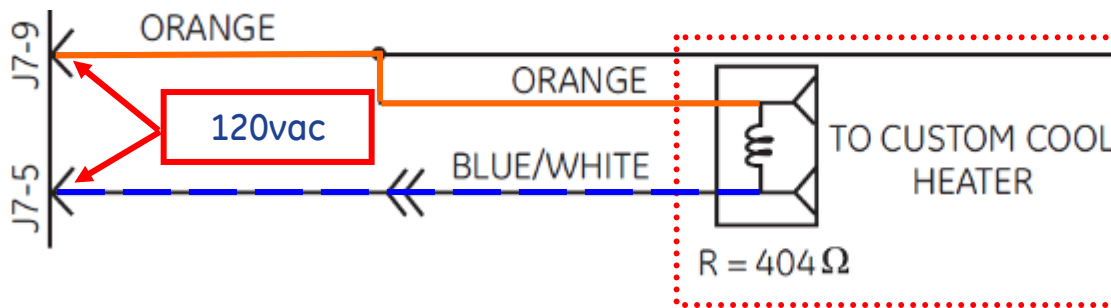

Testing the AC Heaters - K7 Relay J12 Terminal

Some main boards have an additional relay "K7" which can be programmed depending on model to operate various heaters. Refer to the specific model schematic diagram for its use.

The K7 relay outputs AC voltage to the J12 terminal.

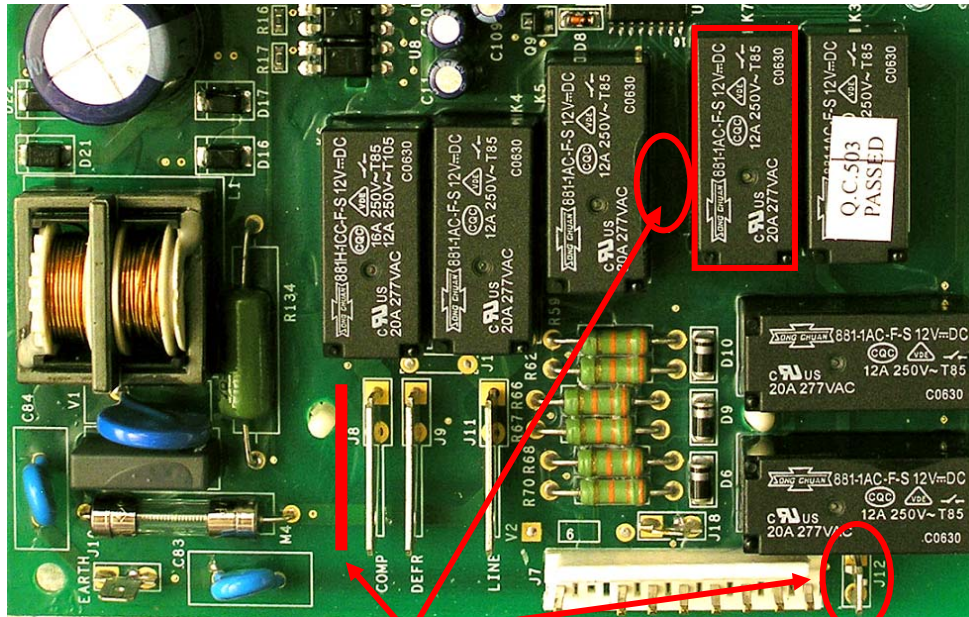

The J12 terminal is located in different locations depending on the main board. It can be a Tab terminal next to the AC connector or an individual Tab on the main board.

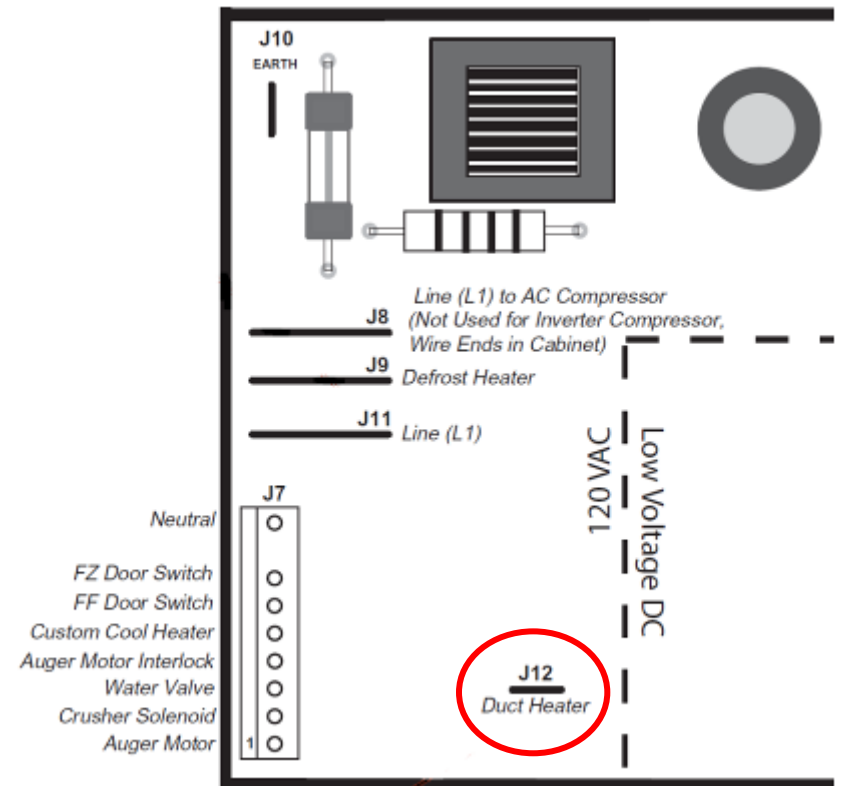

Testing the AC Heaters

Monogram Drain Pan Heater

For Monogram defrost drain pan testing,

use the diagnostic function to enter Defrost. Diagnostic code 1-4.

You should read 120vac from the J12 terminal to J7-9 orange neutral.



Testing the AC Heaters

SxS Beverage Center Duct

Some side by side models have a Beverage Center feature, this is a cooled compartment on the fresh food door. The air duct that cools this compartment is located in the center mullion wall. There is a heater located in this duct to clear any frost build up in the air channel during freezer defrost. Diagnostic code 1-4.

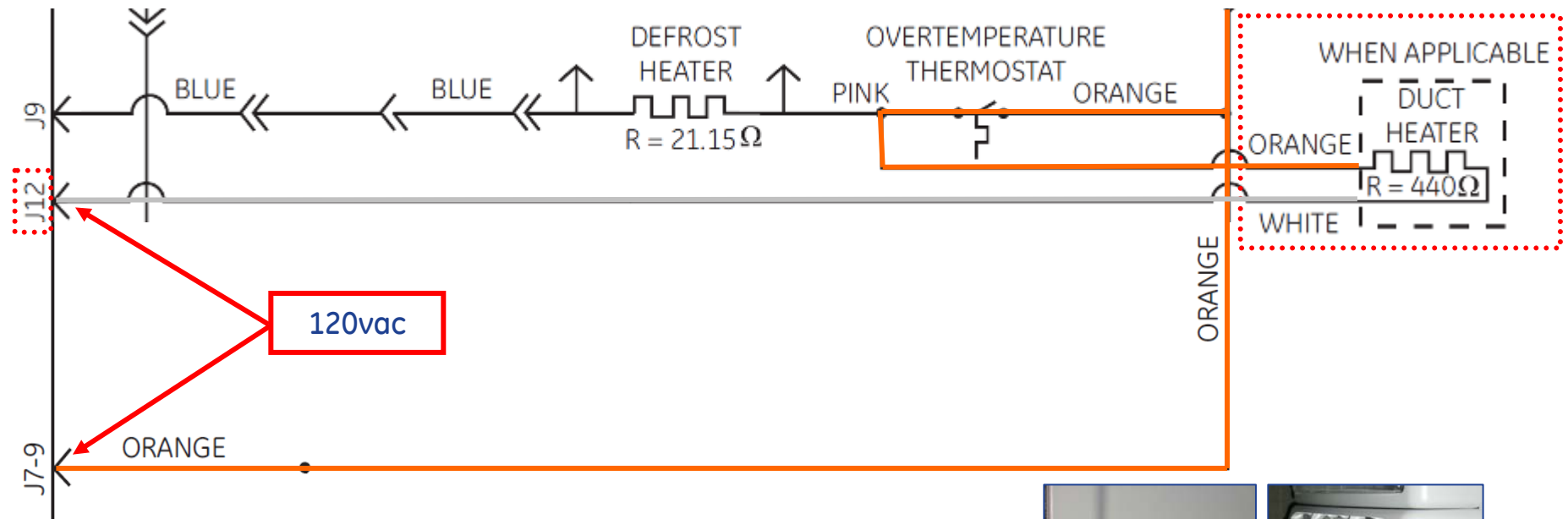

Testing the AC Heaters

French Door Mullion Sweat Heater

Many French door bottom freezer models use a 120vac mullion heater between the freezer and fresh food section. If the mullion is sweating first check the energy save feature to make sure the consumer has not turned the heater off by activating energy save. To test the mullion heater, check resistance or use your meter on the ammeter function.

