

# Electronic Refrigerator Diagnostics

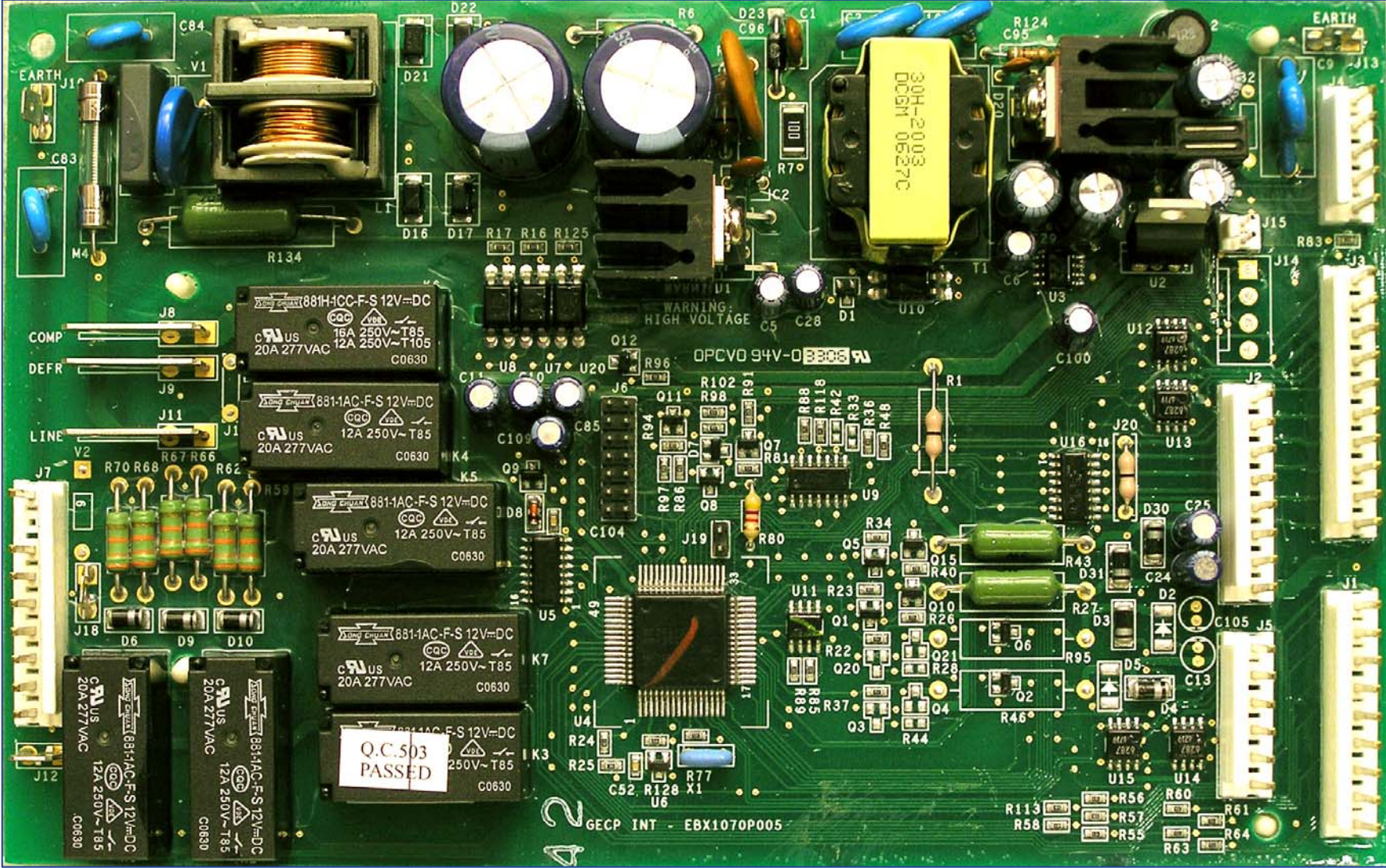

## **IMPORTANT SAFETY NOTICE**

The information in this presentation is intended for use by individuals possessing adequate backgrounds of electrical, electronic, & mechanical experience. Any attempt to repair a major appliance may result in personal injury & property damage. The manufacturer or seller cannot be responsible for the interpretation of this information, nor can it assume any liability in connection with its use.

### **WARNING**

To avoid personal injury, disconnect power before servicing this product. If electrical power is required for diagnosis or test purposes, disconnect the power immediately after performing the necessary checks.

### **RECONNECT ALL GROUNDING DEVICES**

If grounding wires, screws, straps, clips, nuts, or washers used to complete a path to ground are removed for service, they must be returned to their original position & properly fastened.

## Main Electronic Board

**Caution:** When servicing or testing in the main board area, many components and connections are electrically hot to ground. Be sure to use proper service procedures and protection devices.

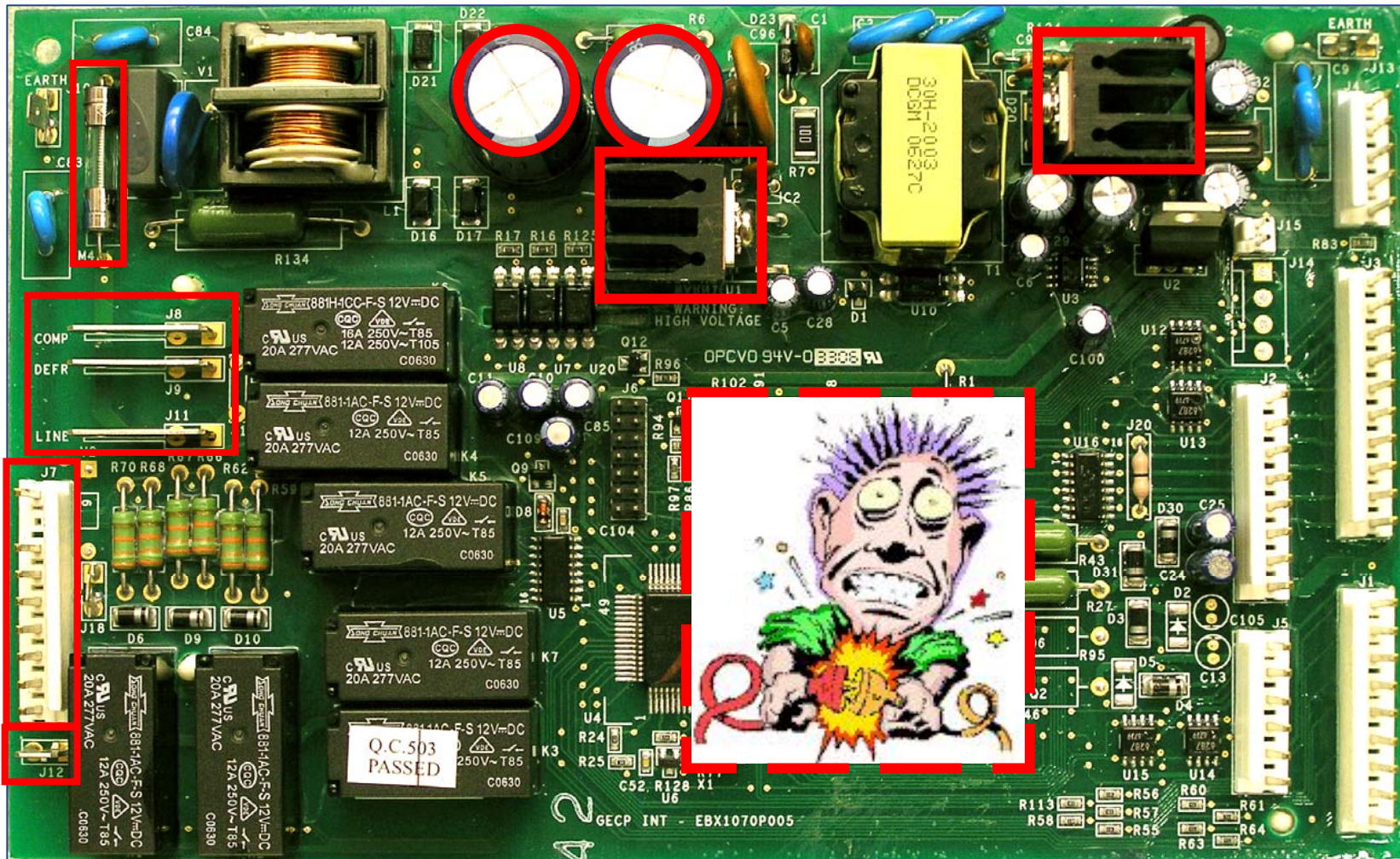

## Electronic Diagnostic Test Mode

All the GE electronic refrigerators have a Diagnostic Mode that is incorporated in the software in each main electronic board. This Diagnostic Mode will test certain components and operate others.

To activate this diagnostic test feature on an electronic refrigerator, you will need a touch pad control with at least 5 key pads; otherwise you will have to install the additional diagnostic tool.

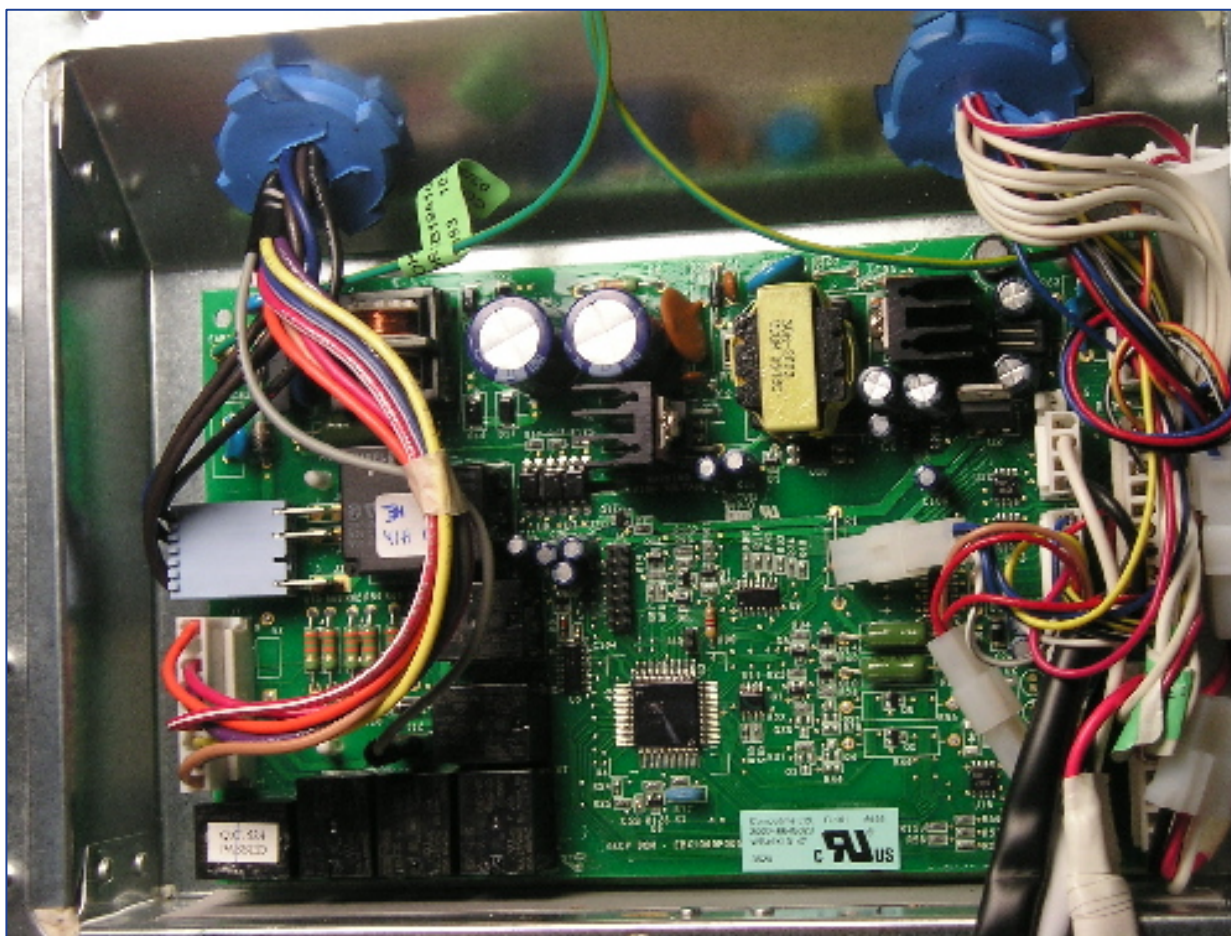

## Diagnostics Aid Kit

The diagnostic aid kit may assist the technician to functionally test individual components.

A diagnostic aid kit can be assembled and consists of a key pad temperature control assembly and wire harness. The parts required are WR55X10390 and WX05X14999.

Using the kit, diagnostics can be performed by removing the base grill and plugging into the diagnostic aid wire harness located on the left side. Diagnostics can also be performed by accessing the main board on the back of the refrigerator and plugging into the harness extended from the board.

**Note:** After plugging in the diagnostic aid kit, if the display is blank, press and release any of the temperature pads. The display will show actual temperatures.

Diagnostic Aid - Front Access



Diagnostic Aid - Main Board Access

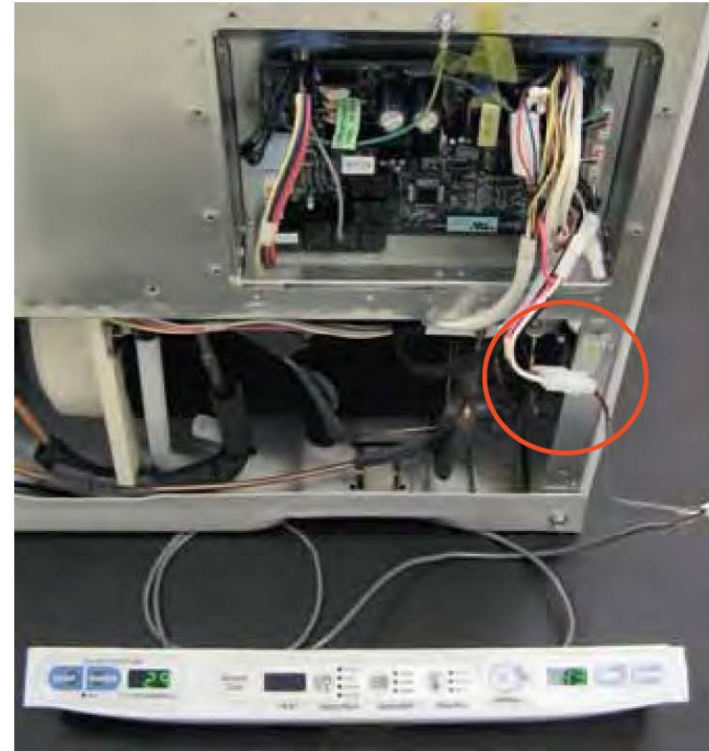

# Electronic Diagnostic Test Mode

## Control Diagnostics

Enter the diagnostic mode by pressing both the freezer temperature (COLDER and WARMER) pads and the refrigerator temperature (COLDER and WARMER) pads simultaneously. All four pads must be held for approximately 3 seconds. Blinking "0"s in both displays indicate the refrigerator has entered the test mode.

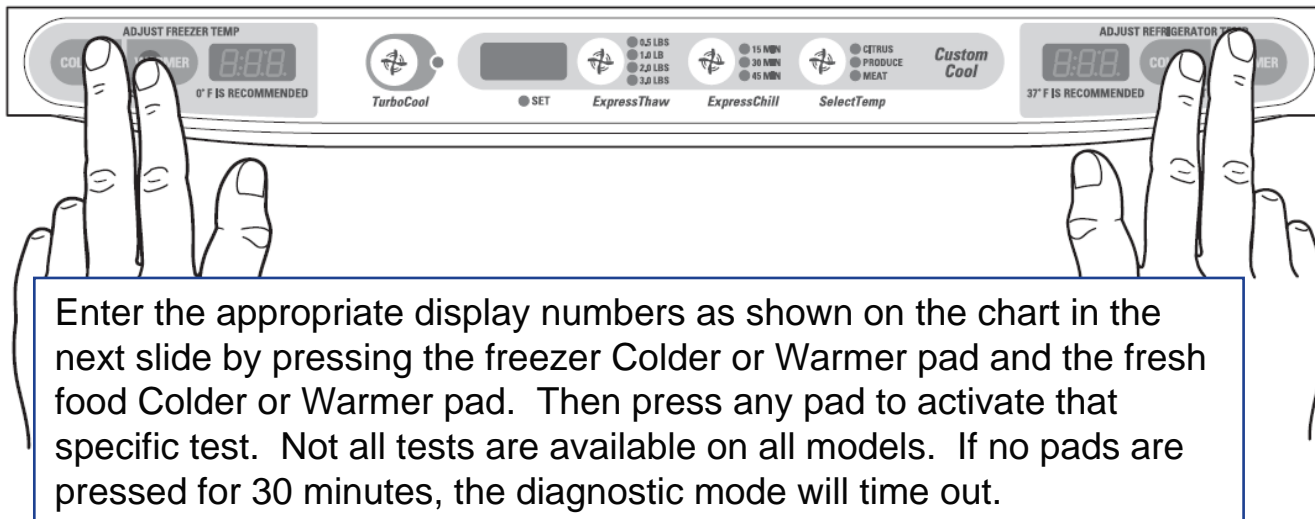

## Electronic Diagnostic Test Mode

| Freezer Display | Fresh Food Display | Diagnostics                    | Results  | Comments   |
|-----------------|--------------------|--------------------------------|--|--|
| 0               | 7                  | Control and Sensor System Test | Checks each thermistor in order.   | See Note 1.  |
| 1               | 0                  | Dampers Test                   | Custom Cool™ damper will open, close after 10 seconds, pause briefly, then single damper will open for 10 seconds. | Test will not start for approximately 20 seconds after pad is depressed. |
| 1               | 1                  | Fan Test                       | Cycles through each fan for 5 seconds.   |  |
| 1               | 2                  | 100% Run Time                  | Sealed system on 100% of the time. Times out after 1 hour.   |  |
| 1               | 4                  | Defrost Test                   | Toggles on the defrost cycle. See Note 2.  | Must press again to turn heater off. See Note 2.                         |
| 1               | 5                  | Main Control Reset/Test Exit   | Causes a system reset and exits test mode.   |  |

This test will not indicate failure for thermistors out of spec

This test will also cycle the FF damper on single evap models

This test will attempt to turn ON the compressor if it is OFF

**Note 1:** Display order is #1 = Fresh Food Evaporator Thermistor, #2 = Fresh Food Thermistor, #3 = CustomCool™ Thermistor, #4 = Freezer Evaporator Thermistor, #5 = Freezer Thermistor.

Thermistor test results are: P = Pass, 0 = Fail, S = Short to 5 VDC, B = Defective board (replace main control).

**Note 2:** You **must** enter the defrost test again to toggle the defrost heater off at the end of the test. The heater will not come on if the evaporator thermistor is above 70°F (21°C).

# Dual Evaporator Model Diagnostics

## Single Evaporator System



## Dual Evaporator System

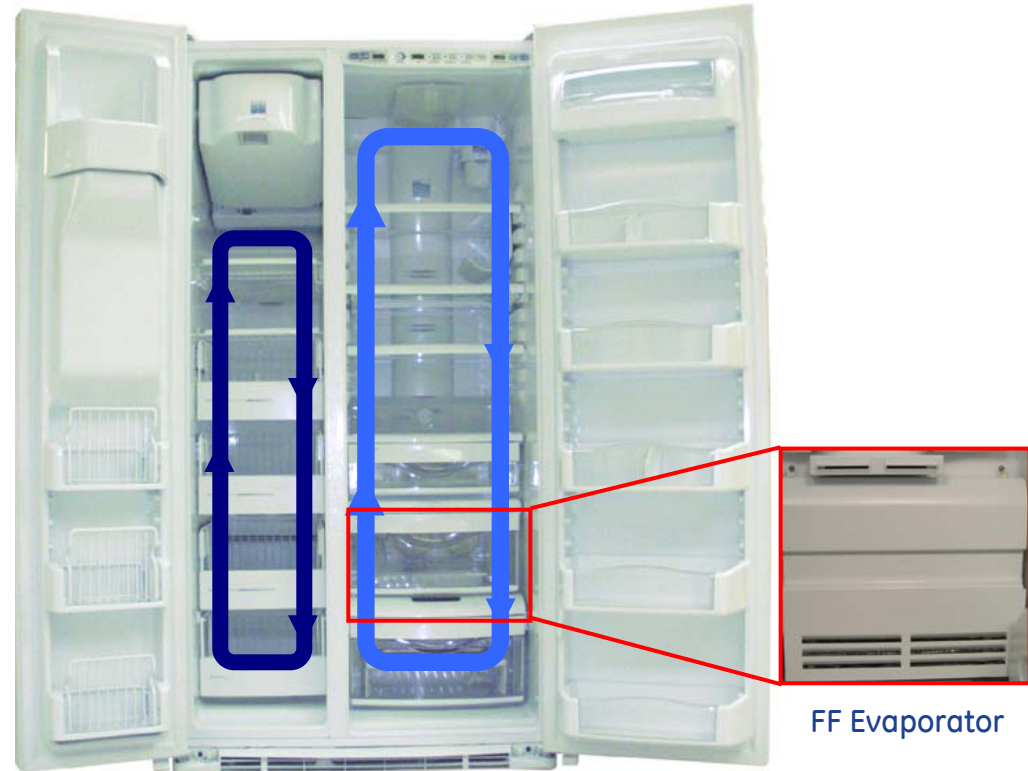

- Dual-Evaporator systems have 2 separate cabinets
- No air return duct from Fresh Food section to Freezer section
- Decreased humidity level in the freezer, defrost cycle is reduced by 20%
- Inverter compressor reduces energy consumption by approximately 50%



# Inverter/Dual-Evaporator System

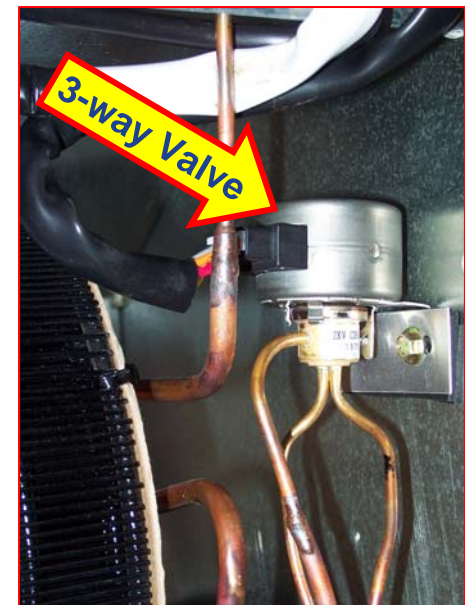
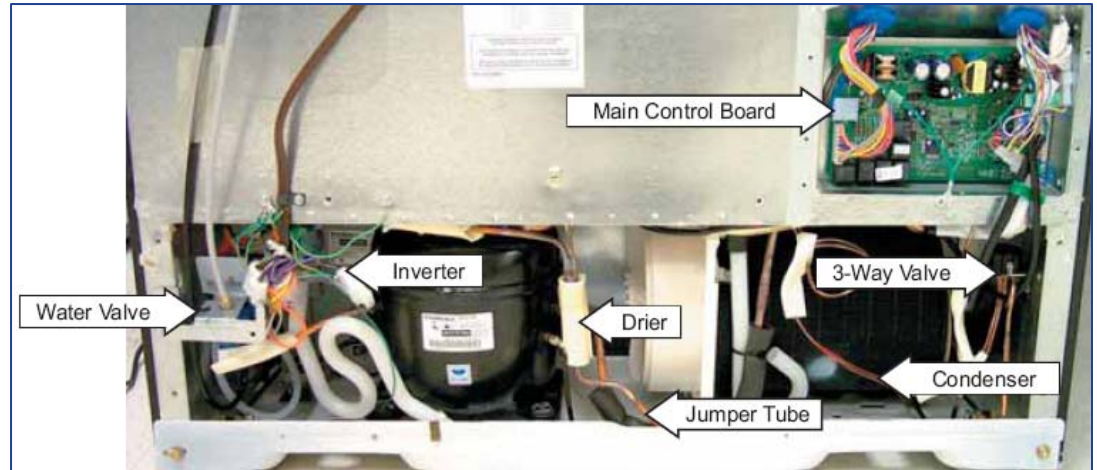
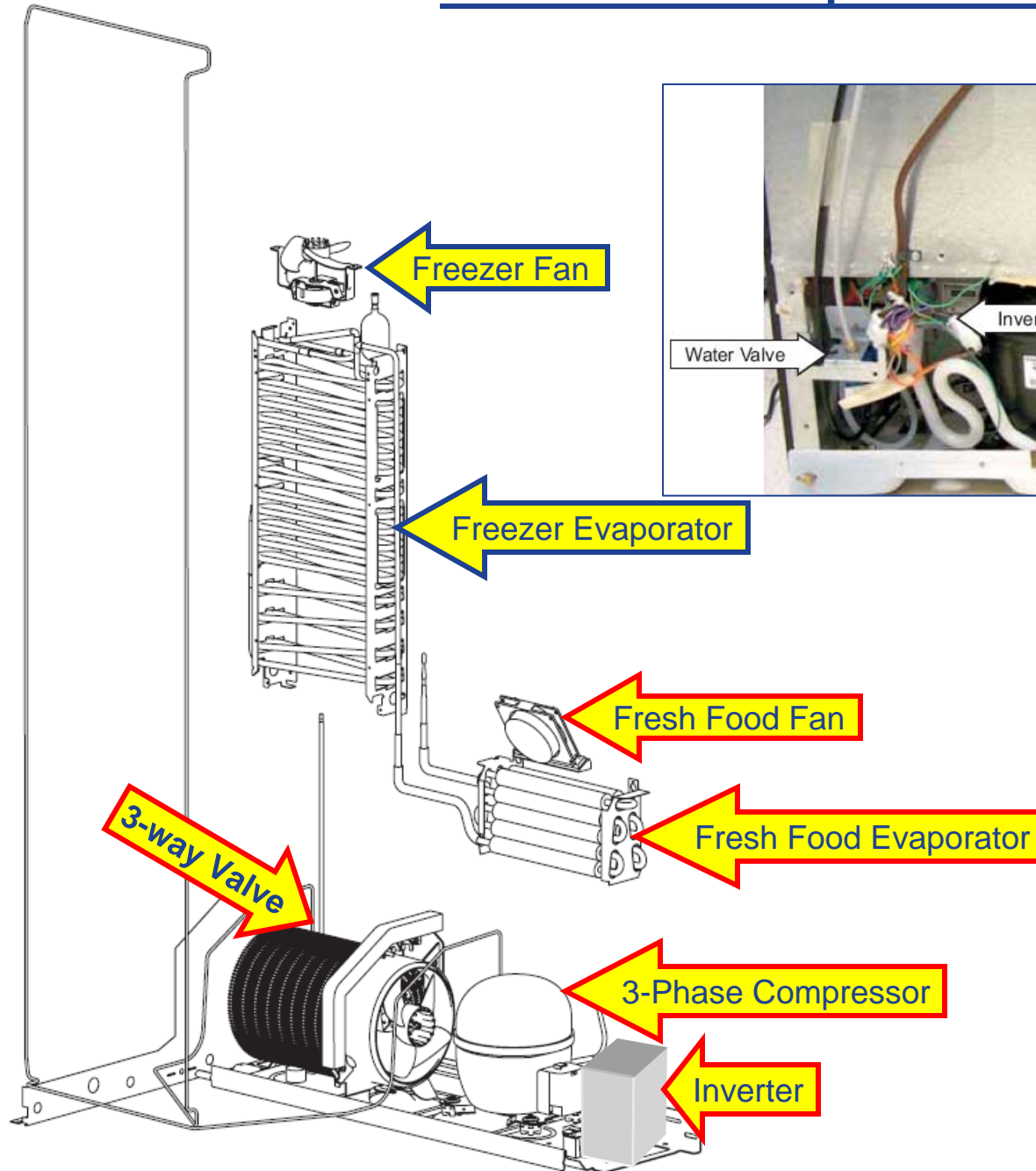

## Inverter (Multi-Speed) Compressors

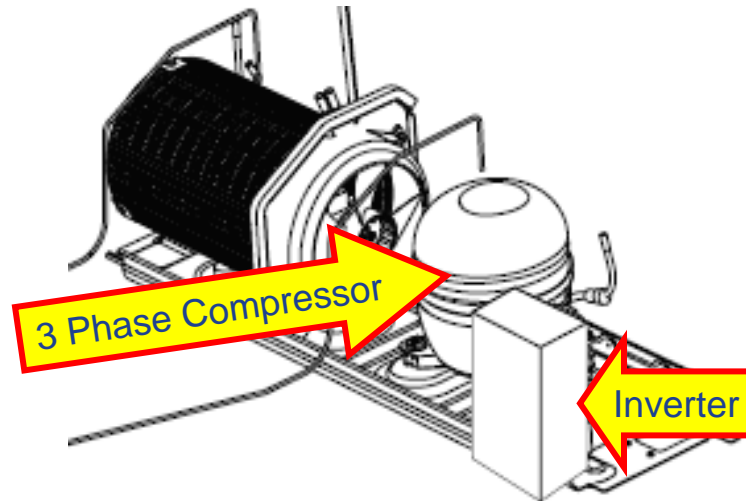

- Inverter (multi-speed) compressors can operate at 3 different speeds (high/medium/low.)
- Inverter compressors are 3-phase components; which use less energy.
- Inverter compressors operate at a much lower temperature; usually slightly above room temperature.
- The compressor is not controlled from the 120vac side of the main board.
- The compressor is now controlled by an inverter.
- The main board still makes compressor decisions based on the input of the Thermistors, door-open time, and input from the temperature control panel.

## Inverter (Multi-Speed) System

- The main board uses a DC voltage “signal” to command the inverter to start the compressor. This “signal” is necessary to activate the inverter; which in turn, activates the compressor. Depending on the DC “signal” (between 4vdc and 6vdc) the compressor could operate at one of the three (high/medium/low) speeds depending on the temperature need, without the DC “signal”, the compressor would not operate.
- When the main board sends the signal to activate the compressor, the compressor will be operating at a specific speed determined by the temperature need of the refrigerator.

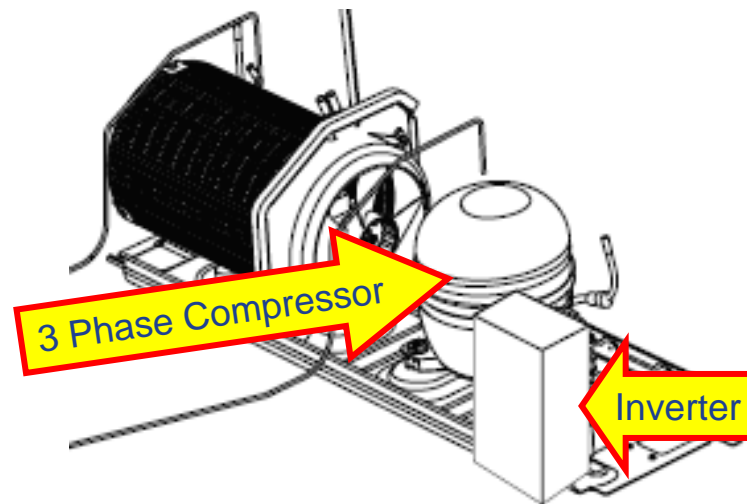

## Inverter Compressor Operation

- Compressor speed is controlled by voltage frequency “signal” and pulse width modulation (PWM). The use of 3-phase power eliminates the need for a relay, capacitor, and individual start and run windings; therefore the start, run, and common pins found on conventional compressors are not applicable on this 3-phase model.
- Compressor pin functions are identical and compressor lead wire configuration is of no importance. A resistance of  $\sim 10\Omega$  read between any two pins will indicate that the compressor windings are within specification. Should an open occur in the compressor winding or should one of the compressor lead wires become open or disconnected, the inverter will stop voltage output to the compressor.
- The inverter receives 120vac from the power supply and converts this single-phase, 60Hz, 120vac into 3-phase, 230vac. This voltage is delivered to the compressor through 3 lead wires. Each wire will carry identical voltage and frequency.

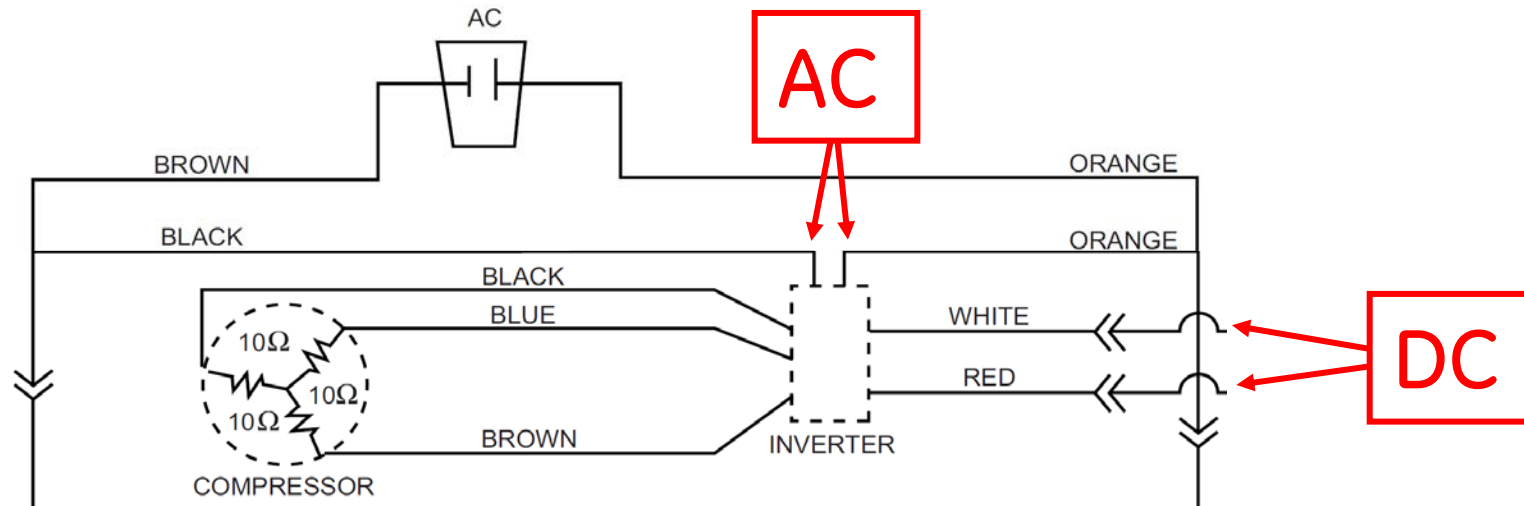

## Inverter Compressor Operation

- Compressor speed is based on the temperature setpoint in conjunction with the cabinet temperature. Speeds are selected according to the cabinet temperatures, with freezer temperature being the primary.
- The inverter monitors compressor operation and if the compressor fails to start or excessive current (4A maximum) is detected, the inverter will briefly stop voltage output. The inverter will make 12 consecutive attempts to start the compressor (once every 12 seconds). If, after 12 attempts, the compressor has not started, an 8-minute count will occur.

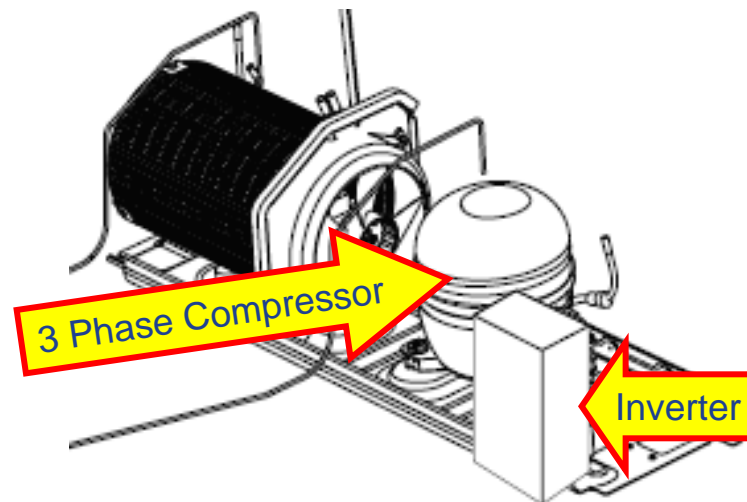

## Inverter Compressor Operation

- After 8 minutes, the inverter will attempt to start the compressor again. If the compressor starts, normal operation will resume. If the compressor fails to start, the above process will repeat.
- Removing power from the unit will reset the inverter count. When power is restored, the inverter will attempt to start the compressor within 8 seconds.

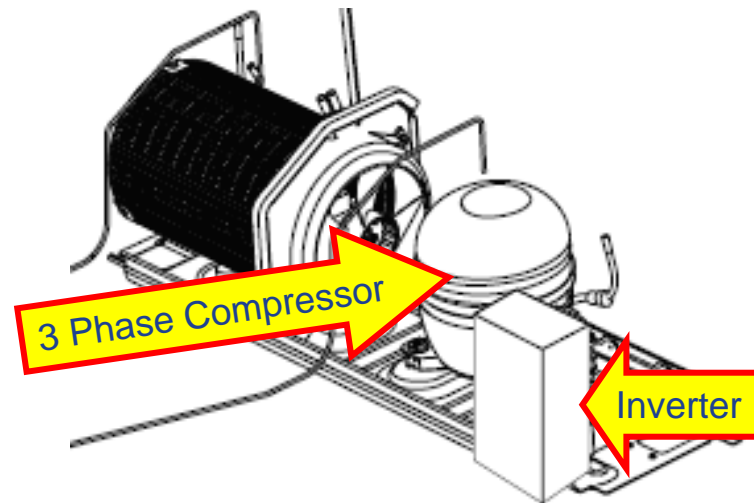

**Warning:** Disconnecting the 6-pin connector does not disconnect power (120 VAC) from the inverter. The refrigerator must be unplugged before servicing the inverter or compressor.

**Caution:** Do not attempt to direct-start the compressor. The compressor operates on a 3-phase power supply. Applying 120 VAC to the compressor will permanently damage the unit. It is not possible to start the compressor without an inverter.

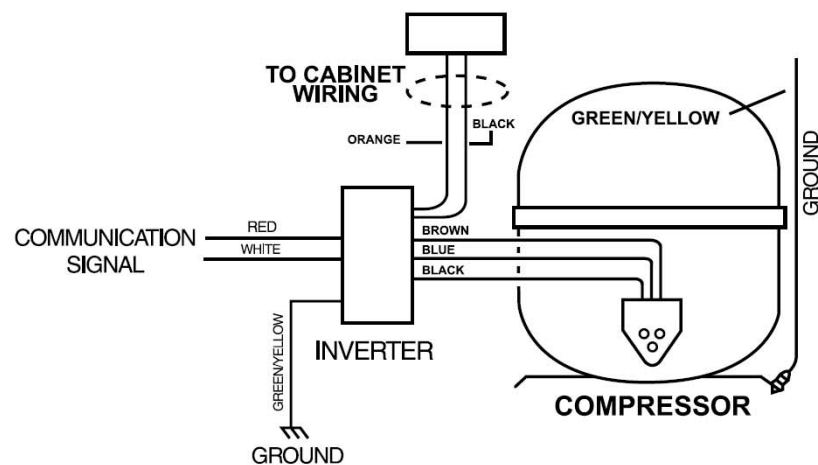

## Main Electronic Board

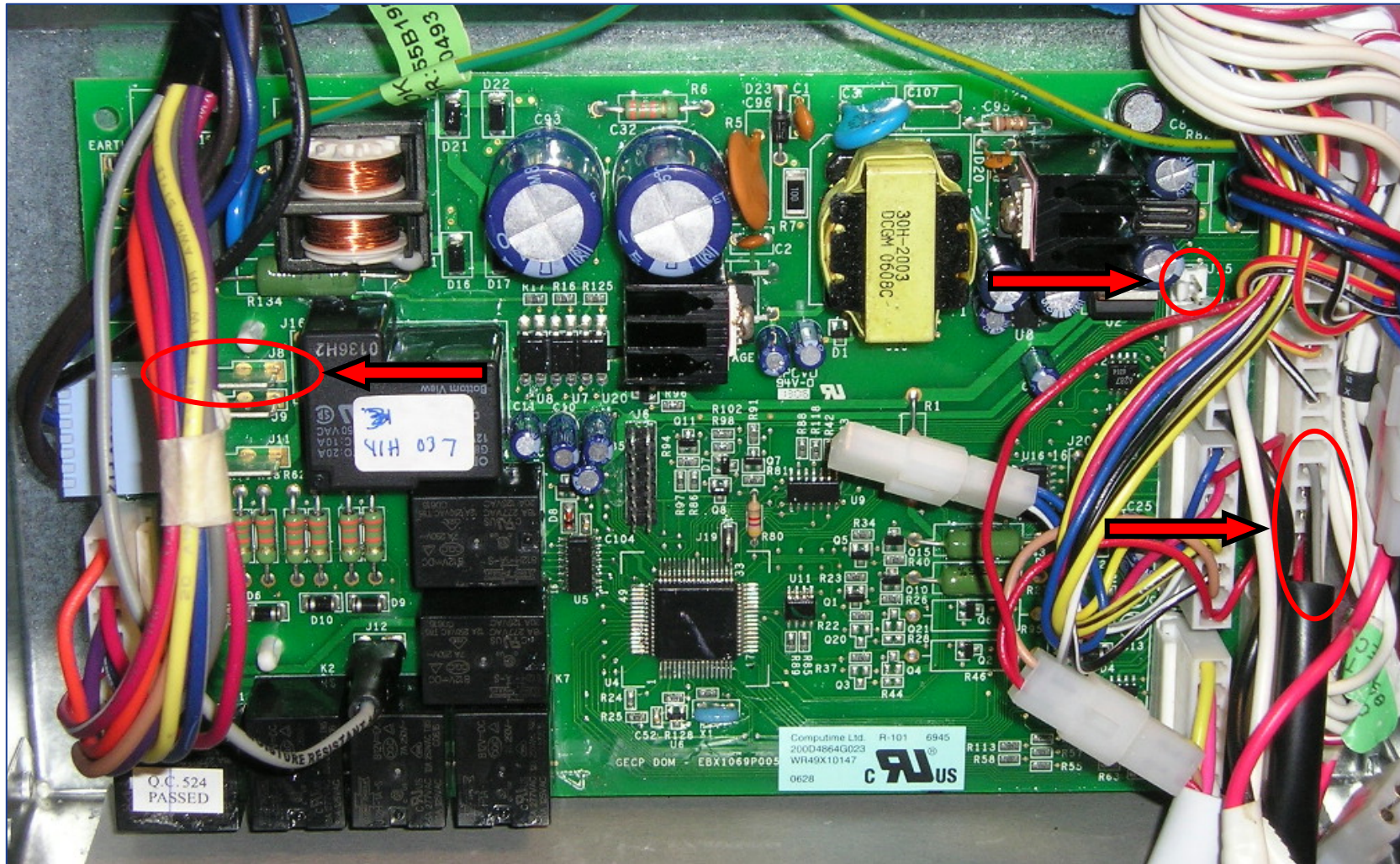

- The main board controls all functions of the electronic refrigerator cooling system.
- The main board for the Dual-Evaporator models has a slightly different layout from single speed models.

# Dual Evaporator Main Control Board Differences

Inverter compressor model main boards do not operate the compressor using 120vac, they utilize a signal frequency (DC voltage) from the J15 connector to control the compressor inverter. The J3 connector also controls the 3-way valve to change the refrigerant flow through the evaporators.

Note that the FF1 thermistor on the J1 connector is used for the FF evaporator temperature.

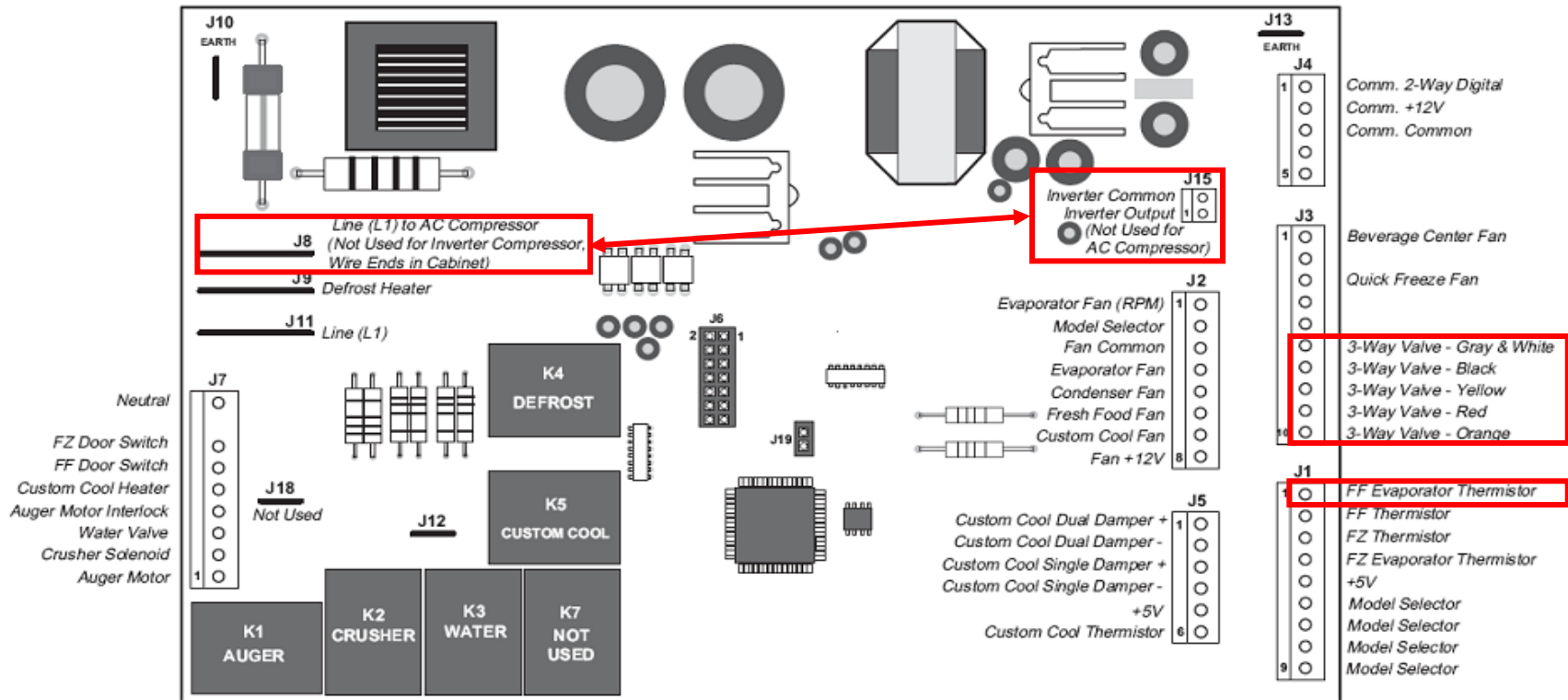



## Inverter Locations

The inverter usually is mounted directly on the compressor or just next to the compressor.

To remove the compressor mounted inverter, remove 1 Phillips screw that secures the inverter to the compressor. Then lift the inverter off the compressor and disconnect the harness.

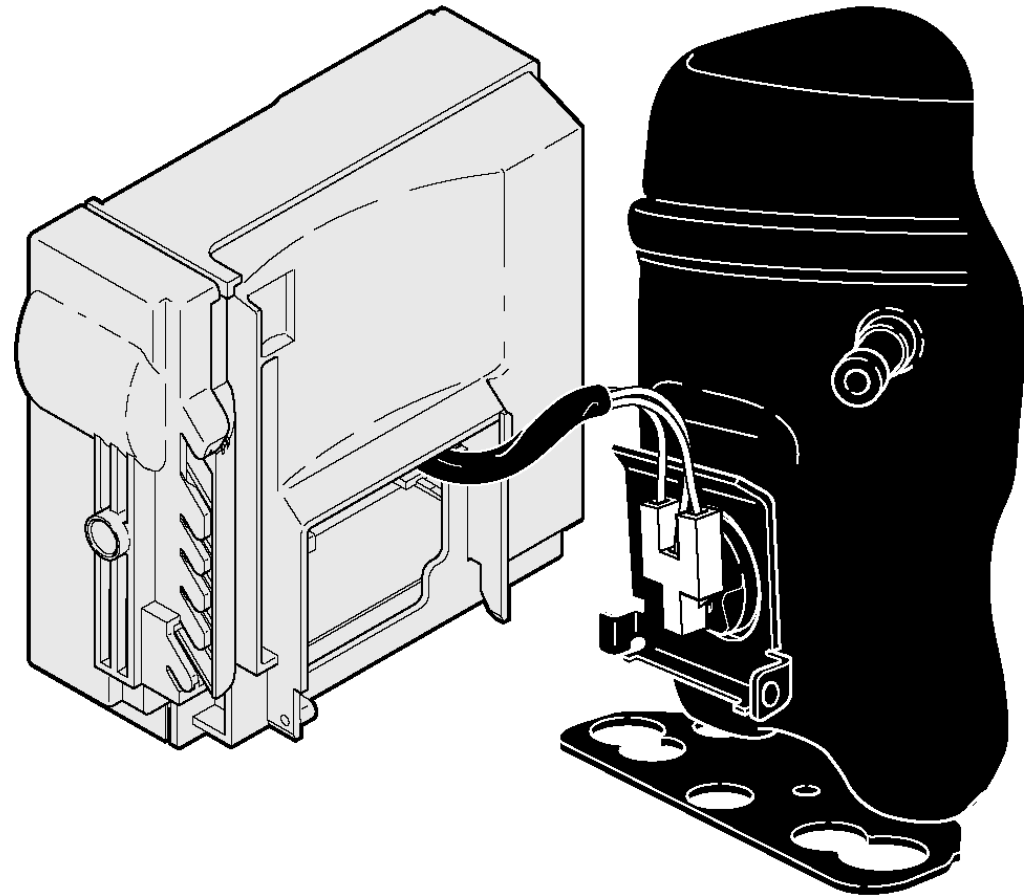
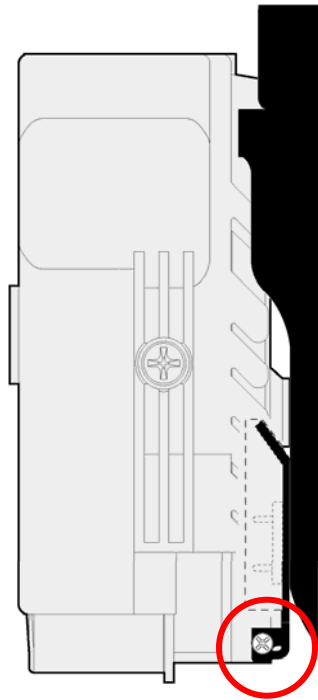

# Compressor Mounted Inverter



When replacing the inverter, set the inverter down beside the compressor and connect the inverter plug to the compressor.

While rotating the inverter onto the compressor make sure the internal cable remains in the bottom of the enclosure so it does not touch the pc board.

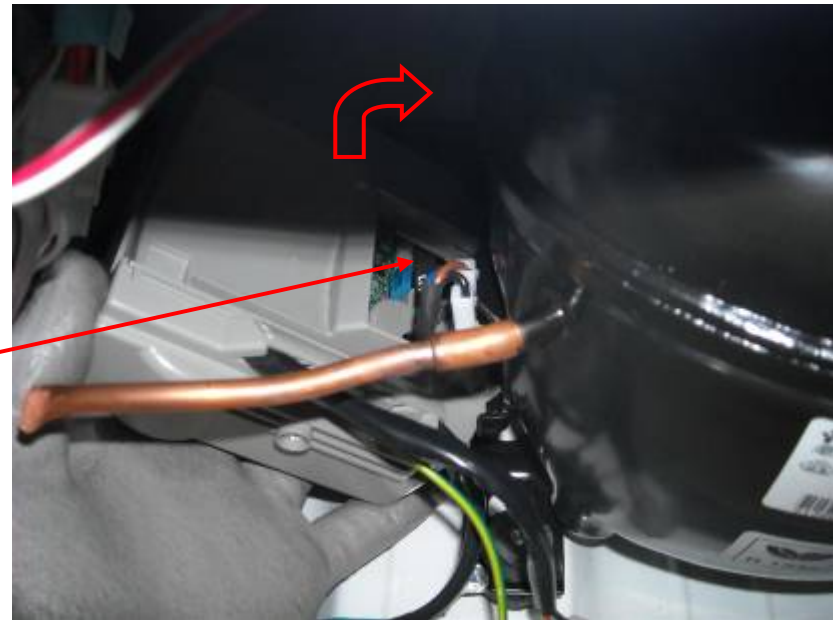

# Inverter Compressor Testing

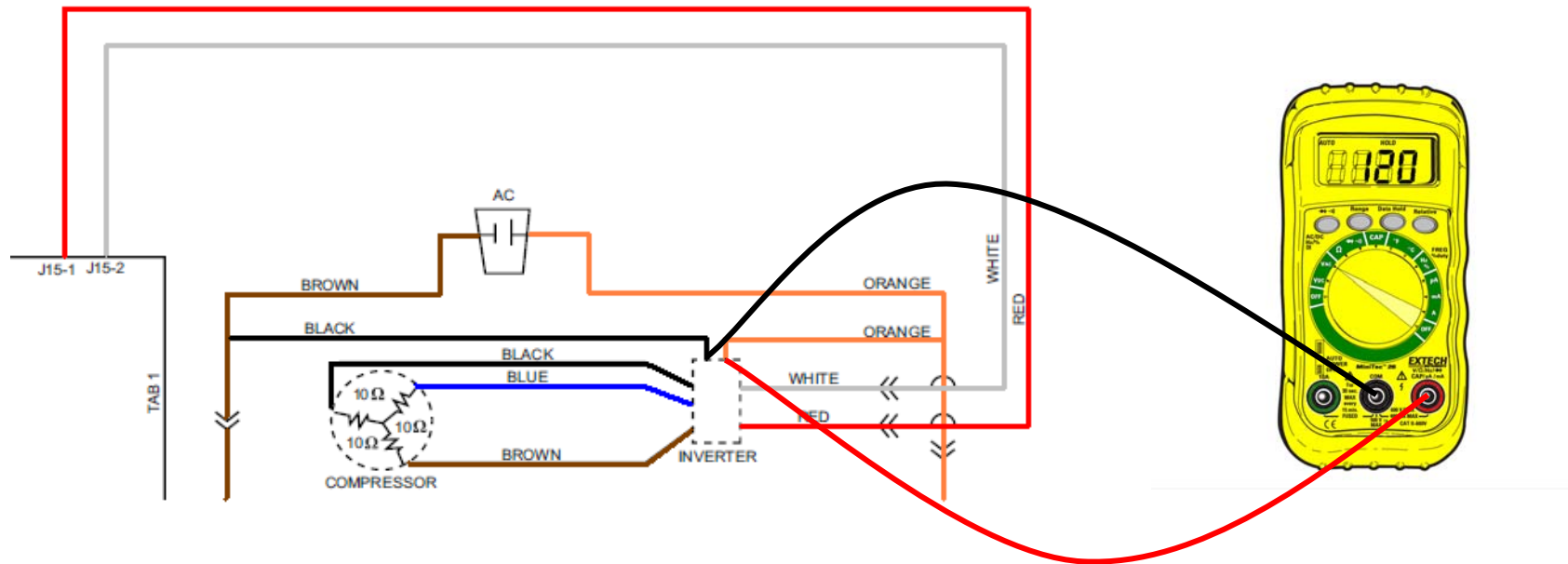

- 1) Using diagnostic mode or the diagnostic aid, place the unit into 100% run mode, code 1-2.
- 2) See if you can detect compressor operation.
- 3) If the compressor does not operate, pull the refrigerator away from the wall.
- 4) Remove the rear machine cover.
- 5) Set meter to ACV.
- 6) Place meter leads on Inverter wire connector (Black and Orange).
- 7) Should read line voltage – if not check wires and repair, otherwise go to next step.



Check the voltage with the connector plugged into the inverter harness.

# Inverter Testing

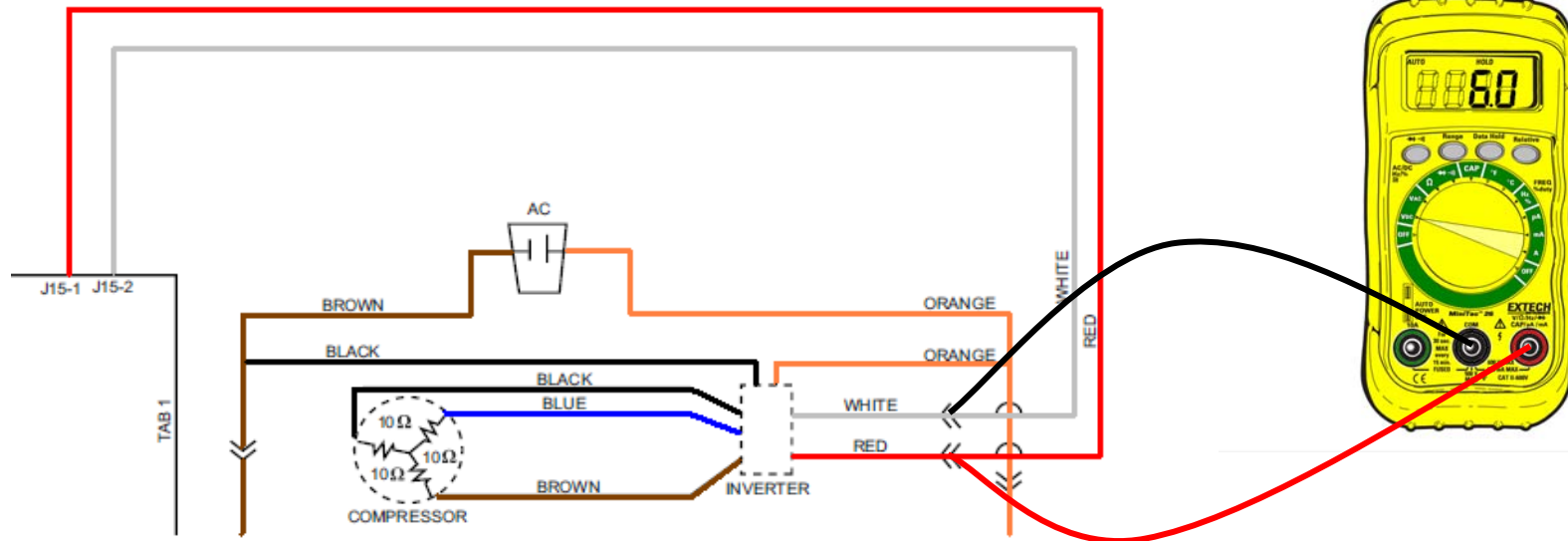

**Note:** When measuring signal voltage (from the main control board) at the inverter, a reading of 4-6 VDC will be measured with all wires connected. If the inverter wiring is disconnected, the board output will measure between 10-12 VDC.

- 8) Set meter to DCV or Hz.
- 9) Place meter leads on Inverter wire connector (White and Red).
- 10) You should read between 4vdc and 6vdc or between 57Hz and 104Hz – if not go to next step, otherwise check compressor windings – any two terminals should read 10Ω and also check each terminal to case, replace compressor if any windings are defective – if not, replace Inverter.
- 11) Remove cover from Main Control Board.
- 12) Place meter leads on J15 pin 1 and J15 pin 2.
- 13) You should read between 4vdc and 6vdc or between 57Hz and 104Hz – if not replace Main Board.
- 14) If correct readings at J15 pin 1 and J15 pin 2, replace wire harness that connects main board to the inverter.

# Inverter Compressor Operation

The inverter receives commands from the main board and will send a Pulse Width Modulated (PWM) run signal between 4vdc and 6vdc effective voltage to the inverter. If your meter can read frequency, the reading will be between 57Hz and 104Hz. The inverter will select compressor speed (voltage output) based on this “signal”. A voltage/frequency “signal” from the main board (J15 pins 1 and 2) lower than 4vdc/57Hz or greater than 6vdc/104Hz indicates a faulty main board. The main board will only send a run “signal” to the inverter when the compressor should run.



Frequency shown

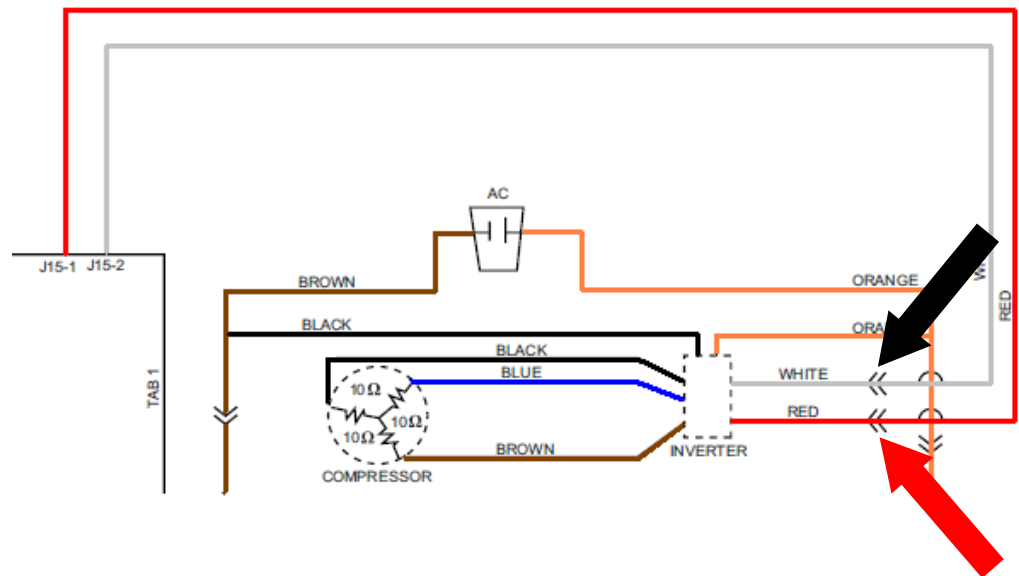

# Main Electronic Board Testing – Inverter Operation

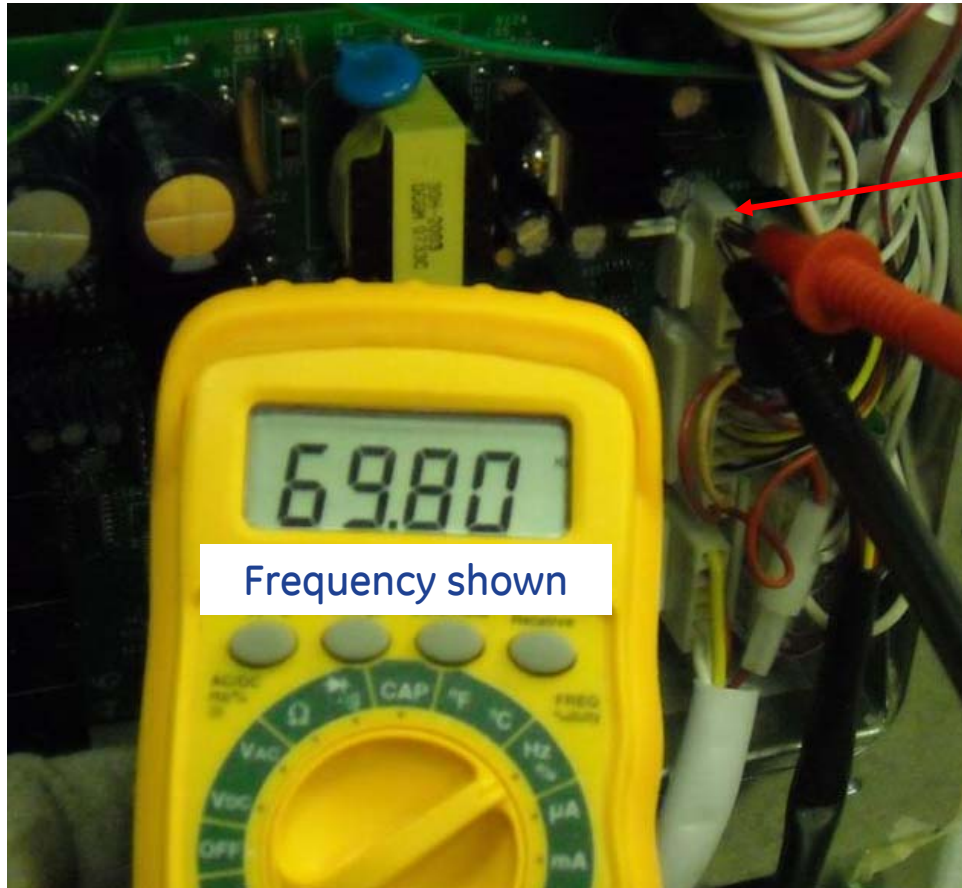

Frequency shown

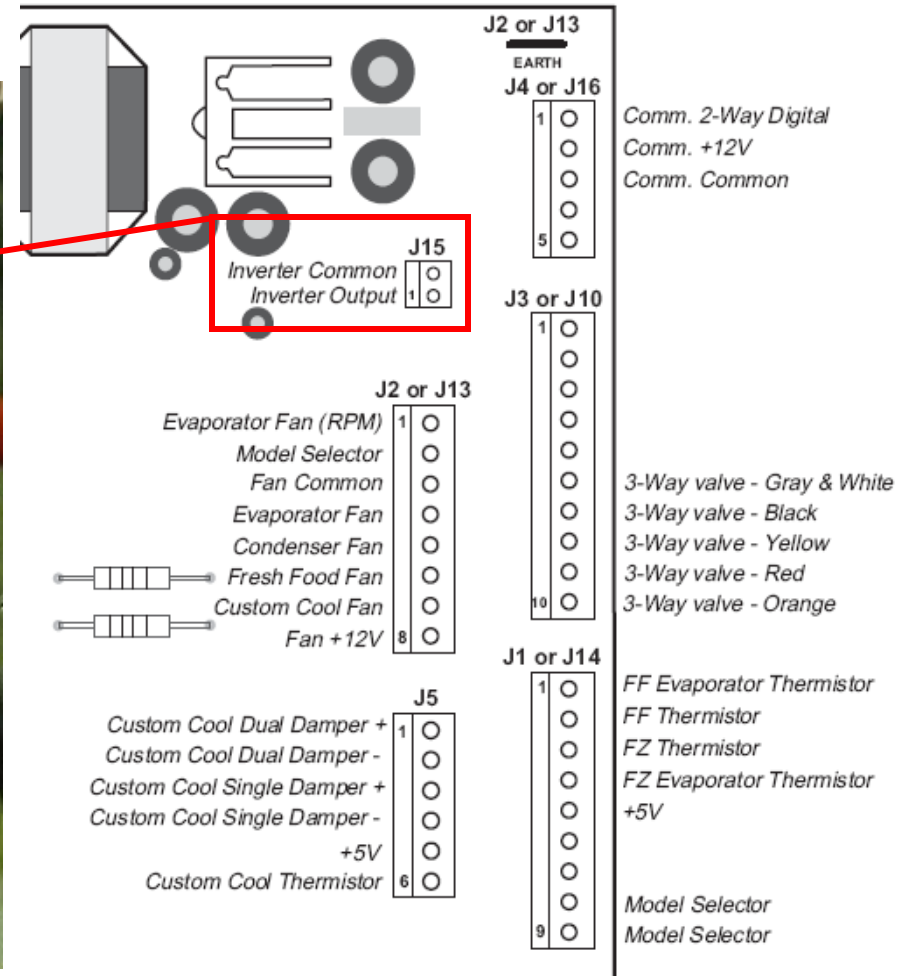

To test board signal for compressor operation, place your meter leads as shown in the above example.

Remember that the compressor gets it's voltage from the Inverter; but first the Inverter must get a "signal" from the main board of between 4vdc/57Hz to 6vdc/104Hz and this is measured between J15 pins 1 and 2.

## 3-Way Valve

- There is no feedback from the 3-way valve to the main board.
- The 3-way valve is made up of a magnetic coil and a valve body.
- After every power up and freezer defrost, the 3-way valve homes itself by overdriving counterclockwise to the stop position; both capillaries are open in the home position.
- The 3-way valve allows refrigerant to flow into both evaporators at the same time, fresh food evaporator alone, or the freezer evaporator alone.

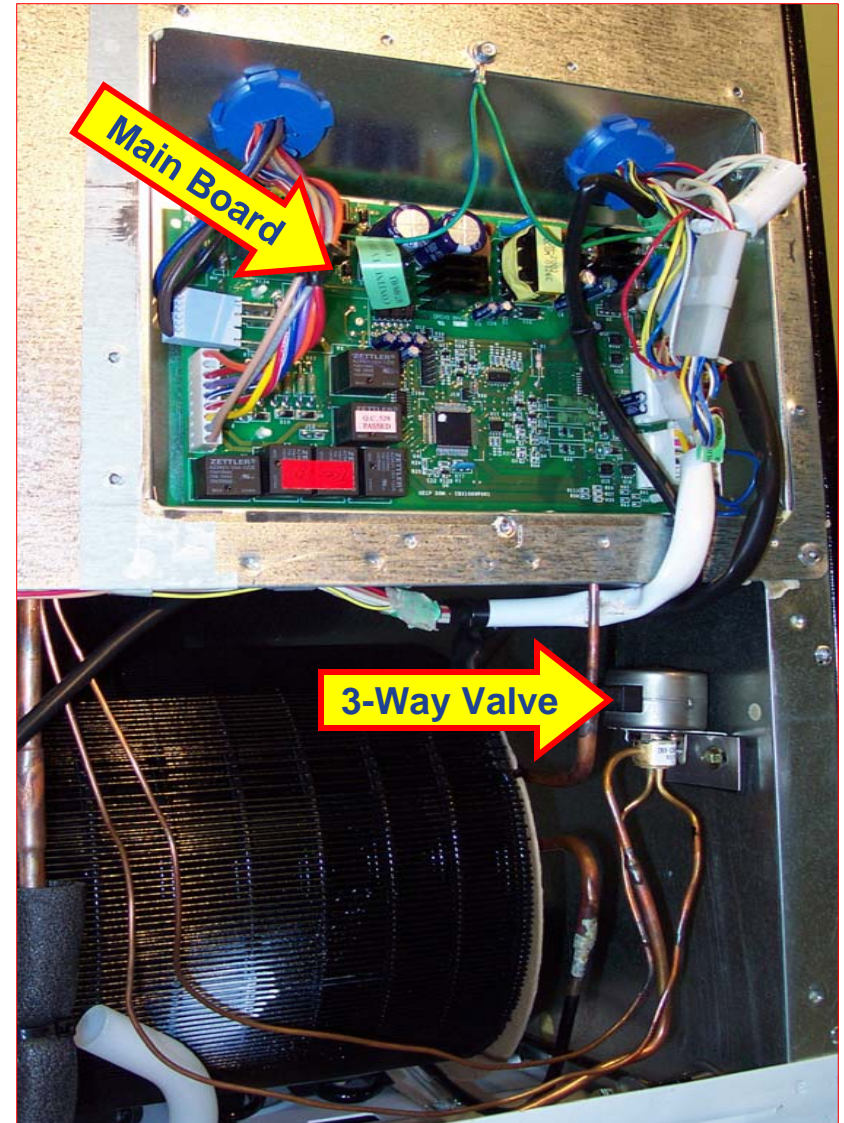
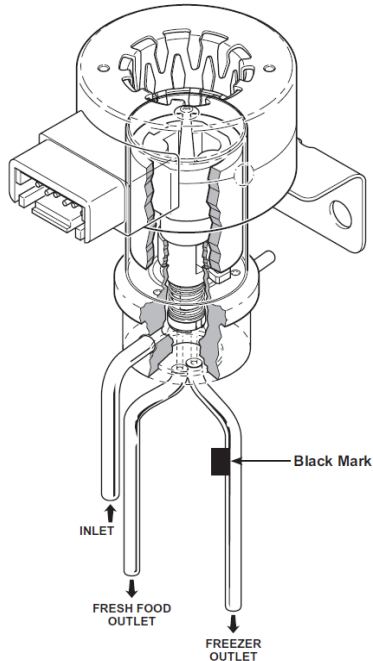



## 3-Way Valve Coil

- The valve coil receives 12vdc pulses from the main board to change the position of the 3-way valve.
- These pulses come too quickly to measure with a volt meter.
- The coil does have a resistance value of  $\sim 46\Omega$ .
- The resistance can be measured between the the following pins on the coil (see the below illustration).

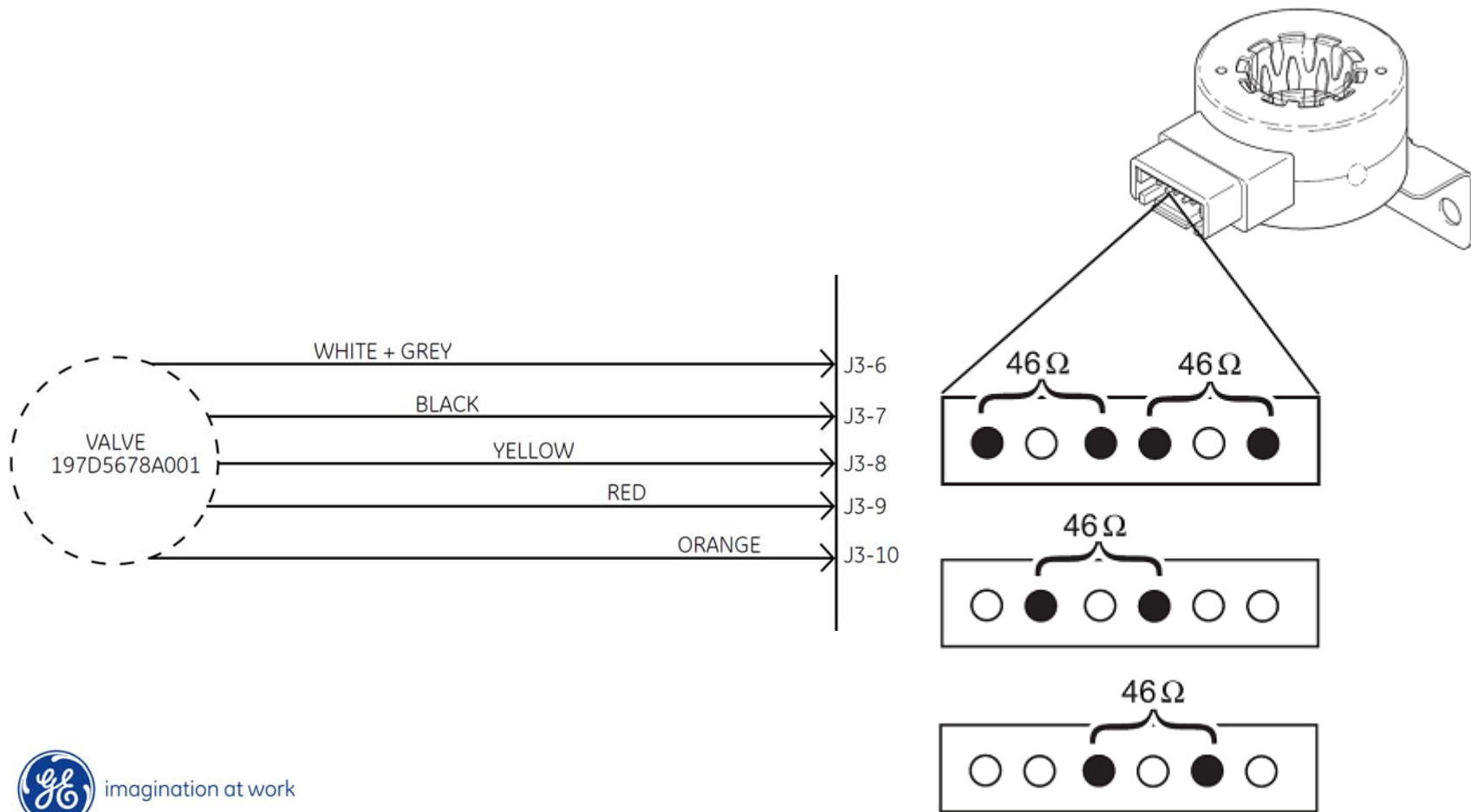

## 3-Way Valve Rotation

- The pulses of the valve coil cause the magnet to rotate inside the valve body.
- As the magnet rotates, it moves the cam at the bottom of the valve.
- The cam opens or covers the “ports” to the capillary tubes.
- The Stop Point (see the illustration on the right) is “Home”.

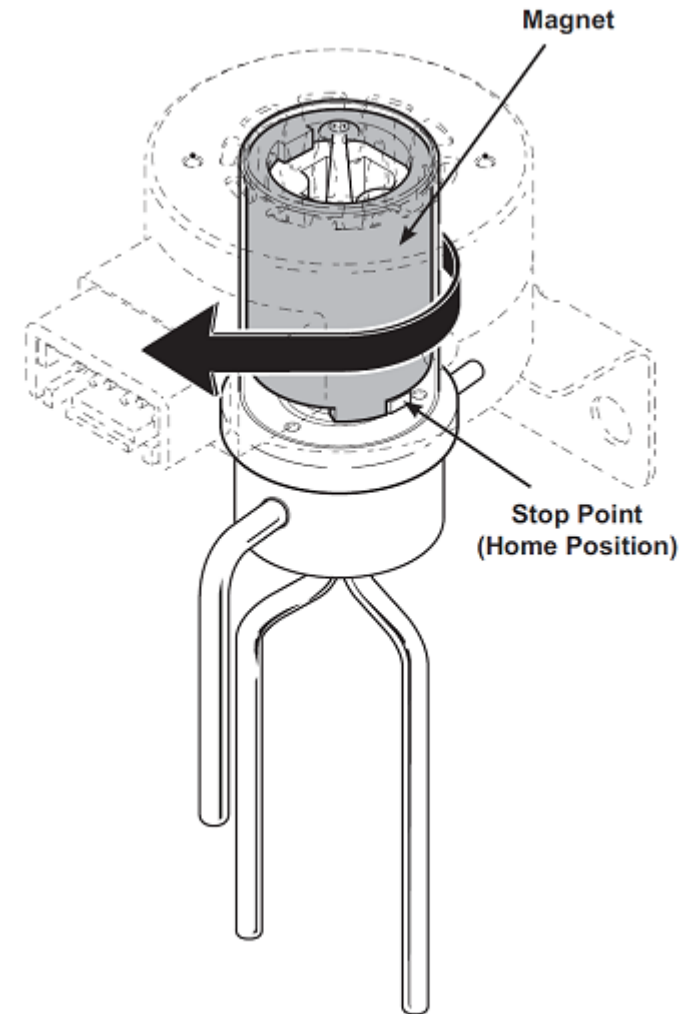
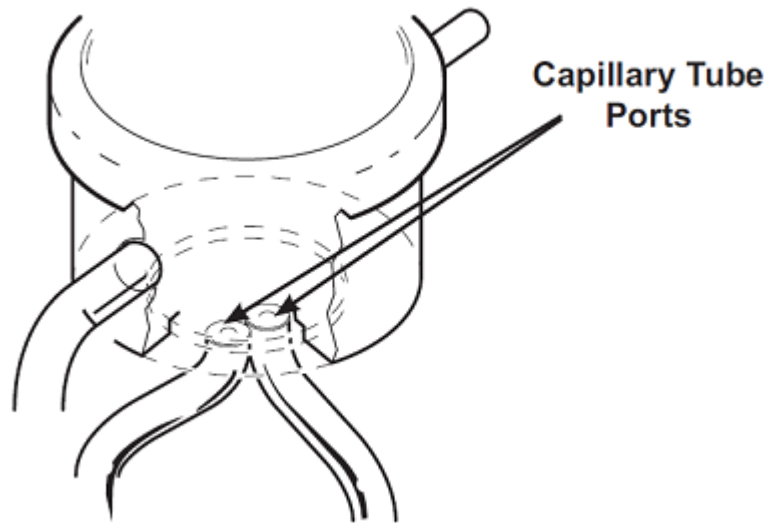

## Testing the 3-Way Valve

- The valve returns to “home” every freezer defrost cycle and whenever the refrigerator is reconnected to power.
- To test the valve, reset the power going to the refrigerator.
- You should be able to “feel” the valve move as it returns to the home position. (Both Open)
- If movement is present, the main board and valve coil are operating correctly.

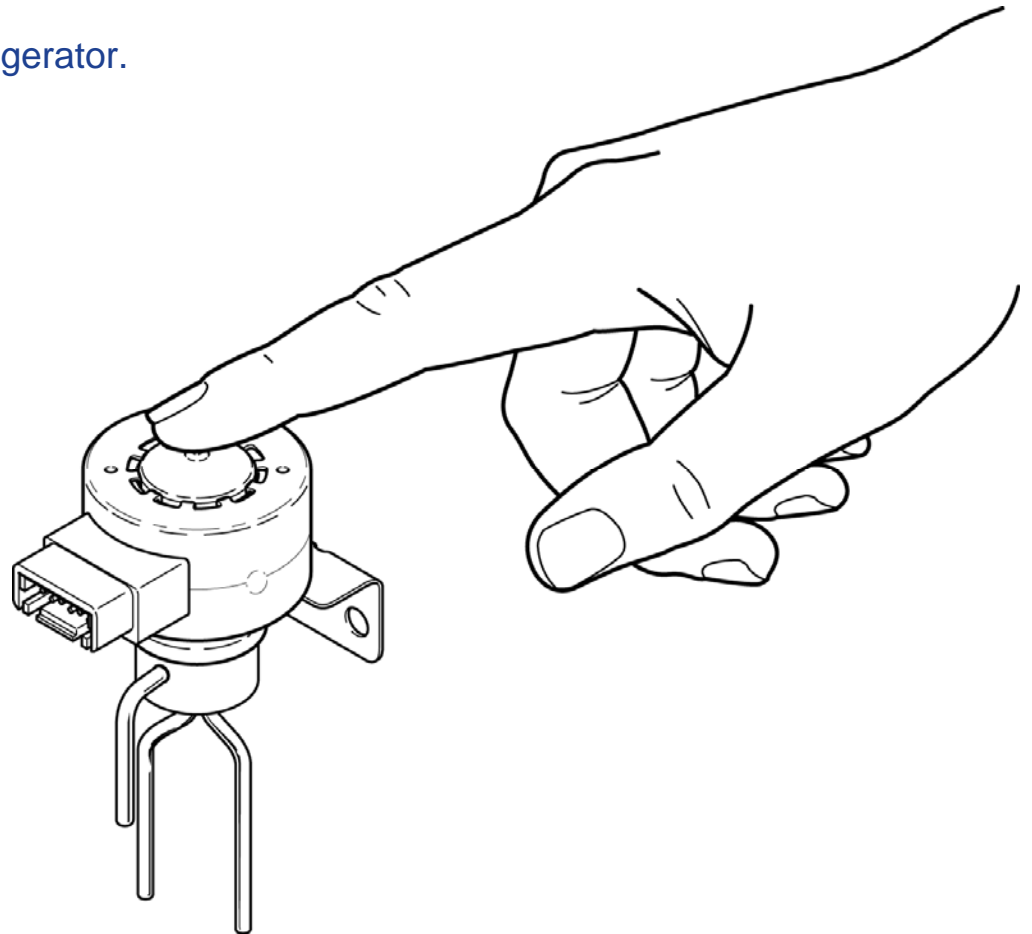

## Testing the 3-way valve manually

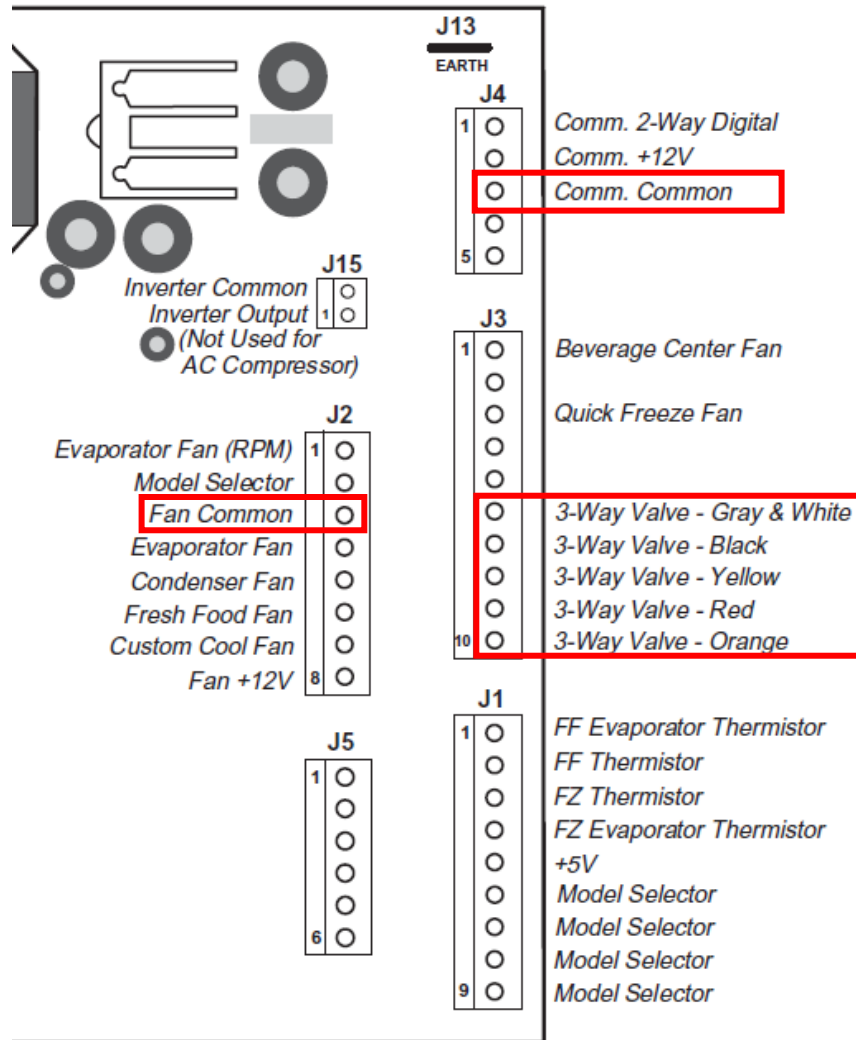

To verify the main board – measure the dc voltage from each J3 3-way valve wire (with the plug connected to the board) to either common board ground at J4 or J2. You should see 12-13 volts dc on each of the 3 way valve wires.

To verify the cabinet wiring; perform the same check from board ground to each of the wires at the 3-way valve connector.

If these checks are OK unplug the refrigerator, disconnect the condenser fan connector, plug the refrigerator back in. Monitor the 3-way valve vibration, when it stops vibrating it is at “home” with both FF and FZ ports open.

Unplug the valve harness at this time.

Monitor the heat output on the two bottom tubes to verify refrigerant flow to both evaporators.

It is VERY important that after this test; you reconnect the 3-way valve and condenser fan; recycle power to the refrigerator to reset the valve.

## Defrost Cycles

- The Dual-Evaporator refrigerator utilizes 2 different defrost methods: a forced air cycle defrost method (no electric heater) to remove frost from the smaller fresh food evaporator and a heated (electric heater) defrost cycle method to remove frost from the larger freezer evaporator.
- Every time the fresh food reaches temperature (using data from the fresh food Thermistor) and refrigerant stops flowing in the fresh food evaporator; the fresh food fan will circulate air producing a forced air defrost cycle.

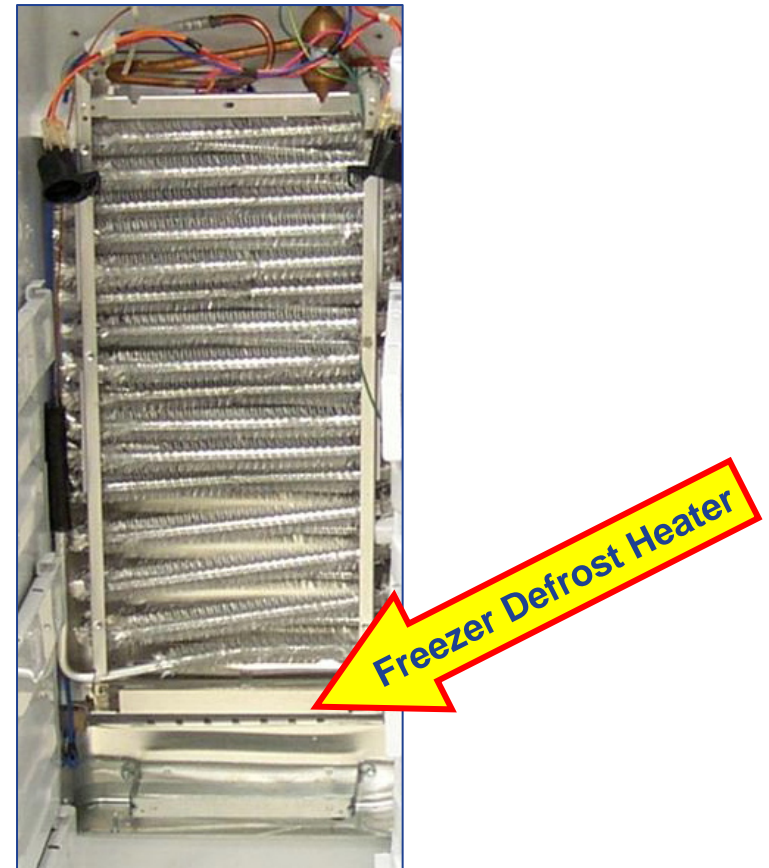

## Fresh Food Evaporator Defrost Cycles

- The Dual-Evaporator refrigerator utilizes a forced air cycle defrost method (no electric heater) to remove frost from the smaller fresh food evaporator.
- Every time the fresh food reaches temperature and refrigerant stops flowing in the fresh food evaporator; the fresh food fan will circulate air that is above freezing temperature through the coil and melts any accumulated frost.
- During fresh food cycle defrost, the compressor may still be operating, cooling the freezer section if necessary.
- There are 4 types of cycle defrost for the fresh food section of the refrigerator: **NORMAL DEFROST, EXTENDED DEFROST #1, EXTENDED DEFROST #2, and FORCED DEFROST.**



Fresh Food  
Air Thermistor



Fresh Food  
Evaporator Thermistor

## Fresh Food Evaporator Defrost Cycles

**Normal Defrost** – The refrigerator utilizes a forced air cycle defrost method to remove frost from the fresh food evaporator. If both freezer and fresh food air Thermistors are satisfied, the compressor cycles off. If the freezer still requires cooling, the main board rotates the 3-way valve to stop refrigerant flow to the fresh food evaporator.

The fresh food fan continues to operate at low speed. The system is designed to run the fan until the fresh food evaporator Thermistor reaches 35°F. Once this temperature is reached, the fan continues to operate at low speed for an additional 5 minutes. (Minimum Defrost)

Under normal conditions, the defrost time takes 30 minutes. The maximum time the fan runs in low speed is 60 minutes. If the fresh food evaporator Thermistor has not reached 35°F after 60 minutes, the main board switches to Extended Defrost #1.

**Extended Defrost #1** – Occasionally there may be excessive frost on the coil. This can be attributed to numerous door openings, extremely high humidity, poor door gasket seal, etc.. If the normal defrost fan time exceeds 60 minutes, the fan switches to high speed. The main board continues to monitor the fresh food evaporator Thermistor for 35°F. When 35°F is reached, the fan operates for an additional 5 minutes at high speed, then shuts off. The fan can run up to an additional 30 minutes at high speed trying to reach 35°F. After 90 total minutes of fan time (60 at low speed and 30 at high speed), if the fresh food evaporator Thermistor is still below 35°F, the main board will switch to Extended Defrost #2.



## Fresh Food Evaporator Defrost Cycles

**Extended Defrost #2** – If the fresh food fan has been operating for 90 minutes, the main board searches for a fresh food air Thermistor temperature above 52°F. If the fresh food air Thermistor is above 52°F, the main board assumes there is a problem reading the fresh food evaporator Thermistor, ends the defrost cycle, and returns to normal cooling.

If the fresh food air Thermistor is less than 52°F, the main board assumes there is a refrigerant leak through the 3-way valve, keeping the fresh food evaporator cold during the defrost process while the freezer evaporator is cooling. **The main board shuts off the compressor** and runs the fresh food fan at high speed until 2 conditions are met: the evaporator Thermistor reaches 35°F and the fresh food air Thermistor is 2½°F above set point. As in the other cycles, the fan continues to run for an additional 5 minutes after the evaporator temperature of 35°F is reached.

**Forced Defrost** – If the main board senses the fresh food section has been cooling for 45 minutes, it immediately stops the refrigerant flow through the fresh food evaporator. The main board changes the position of the 3-way valve if cooling is still required in the freezer, or turns the compressor off if the freezer is satisfied. The fresh food fan operates on high speed until the evaporator reaches 35°F, plus an additional 5 minutes.

**Note:** If the fresh food evaporator Thermistor is either open or shorted and the 35°F cutoff can't be determined, the main board defaults to a fixed defrost cycle of 1 hour at high speed fan.



## Dual Evaporator Refrigerator Diagnostics

- Incorrect operation of the fresh food section may effect freezer temperatures, a frosted evaporator or inoperable fresh food evaporator fan may cause an extended defrost condition in which the main board may shut down the compressor for extended periods of time.
- Confirm proper operation by comparing the actual FF thermistor temperatures to resistance on temperature/resistance chart. (resistances may be checked at J1 pin 2 to pin 5)
- Confirm fresh food evaporator fan operation.
- Check fresh food evaporator for excessive build up of frost or ice, excessive build up may be from an out of range thermistor, erratic operation or intermittent evaporator fan or a three way valve leaking through.
- Confirm proper operation of ff evaporator thermistor by checking actual thermistor temperature to resistance on temp / resistance chart. (Resistances may be checked at J1 pin 1 to pin 5)
- Dual evaporator and variable speed models use specific main boards, always verify the part number before replacement. Many models have a sticker on the back of the cabinet listing the main board part number.