

# 2012 French Door Refrigerator



# Louisville Built Bottom Freezer Refrigerator

**MISSION 1**

**PFE29PSDASS**

**GFE29HSDASS**

**GFE29HGDABB**

**GFE29HGDAWW**



# Large Stainless Steel Dispenser

GE



GE Profile



GE Cafe



Industry First

Hands Free AutoFill



Industry First

# Advanced filtration with Filter in the Door



Live safer.®



imagination at work



Temperature Controlled Drawer with  
Colored LED Lights

# Drop Down Tray





Space-Saving Icemaker



# Dual Icemakers



# Showcase LED Lighting



# TwinChill™ Evaporators



imagination at work

# Winning Features

TwinChill™

Showcase LED Lighting

Space-Saving Icemaker

Hands Free AutoFill

Advanced Filtration with the Filter in the Door

Large Sleek Dispenser

3 Freezer Drawers

Drop Down Tray

Temperature Controlled Drawer

## PFE29PSDSS



- Fresh Food door ice and water
- Electronic control deli pan
- 4.3" LCD door control
- Fresh Food 7 Pin-Point LED lighting

## GFE29HSDSS & GFE29HGDBB/WW



- Fresh Food door ice and water
- 2<sup>nd</sup> icemaker in the freezer
- Mechanical control deli damper
- Segment LED door display
- Fresh Food 5 Pin-Point LED lighting

## **IMPORTANT SAFETY NOTICE**

The information in this presentation is intended for use by individuals possessing adequate backgrounds of electrical, electronic, & mechanical experience. Any attempt to repair a major appliance may result in personal injury & property damage. The manufacturer or seller cannot be responsible for the interpretation of this information, nor can it assume any liability in connection with its use.

### **WARNING**

To avoid personal injury, disconnect power before servicing this product. If electrical power is required for diagnosis or test purposes, disconnect the power immediately after performing the necessary checks.

### **RECONNECT ALL GROUNDING DEVICES**

If grounding wires, screws, straps, clips, nuts, or washers used to complete a path to ground are removed for service, they must be returned to their original position & properly fastened.

GE Factory Service Employees are required to use safety glasses with side shields, safety gloves & steel toe shoes for all repairs



**Dyneema<sup>®</sup>  
Cut  
Resistant  
Glove**



**Electrically Rated Glove  
and Dyneema<sup>®</sup> Cut  
Resistant Glove Keeper**



**Plano Type Safety Glasses**



**Steel Toe  
Work Boot**

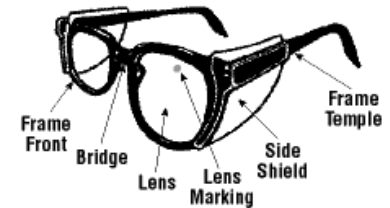

**Prescription Safety  
Glasses**



**Brazing Glasses**

**Safety Glasses must be  
ANSI Z87.1-2003  
compliant**



GE imagination at work

## Refrigerator Warranty. *(For customers in the United States)*



All warranty service provided by our Factory Service Centers or an authorized Customer Care® technician. To schedule service, on-line, visit us at [GEAppliances.com](http://GEAppliances.com), or call 800.GE.CARES (800.432.2737). Please have serial number and model number available when calling for service.

Staple your receipt here.  
Proof of the original purchase date is needed to obtain service under the warranty.

### For The Period Of: GE Will Replace:

#### GE and GE PROFILE MODELS:

##### One Year

*From the date of the original purchase*

**Any part** of the refrigerator which fails due to a defect in materials or workmanship. During this **limited one-year warranty**, GE will also provide, **free of charge**, all labor and related service to replace the defective part.

##### Thirty Days

*(Water filter, if included)  
From the original purchase date of the refrigerator*

**Any part** of the water filter cartridge which fails due to a defect in materials or workmanship. During this **limited thirty-day warranty**, GE will also provide, **free of charge**, a replacement water filter cartridge.

#### GE PROFILE MODELS ONLY:

##### Five Years

*(GE Profile models only)  
From the date of the original purchase*

**Any part of the sealed refrigerating system** (the compressor, condenser, evaporator and all connecting tubing) which fails due to a defect in materials or workmanship. During this **limited five-year sealed refrigerating system warranty**, GE will also provide, **free of charge**, all labor and related service to replace the defective part in the sealed refrigerating system.



GE imagination at work



# Fresh Food Section

# Upper Hinge Cover Removal

Remove three ¼" screws from the top hinge cover

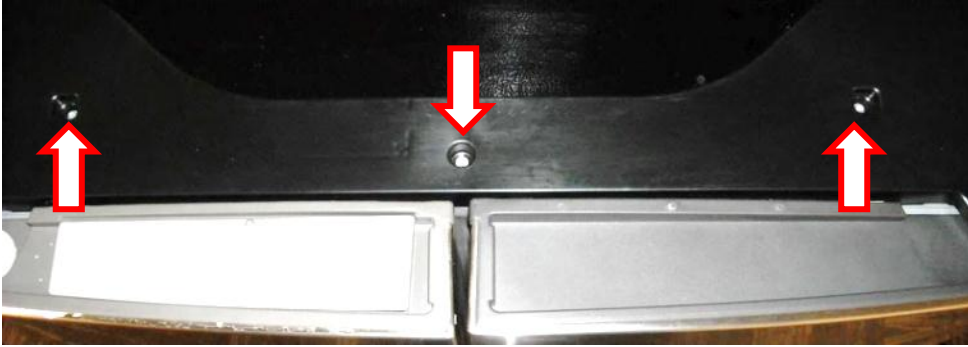

Open both fresh food doors to 90°

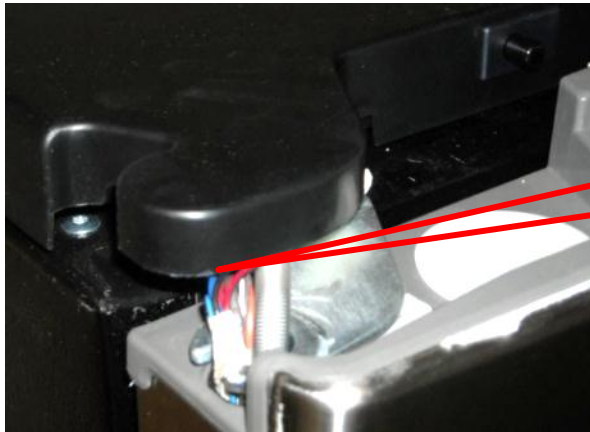

Move the cover slightly forward to release the tabs from the hinges and slide back.

# Fresh Food Dispenser Door Removal

Remove the hinge cover assembly and lay the cover back onto the cabinet to access the top hinge screws, wiring and water tubing.

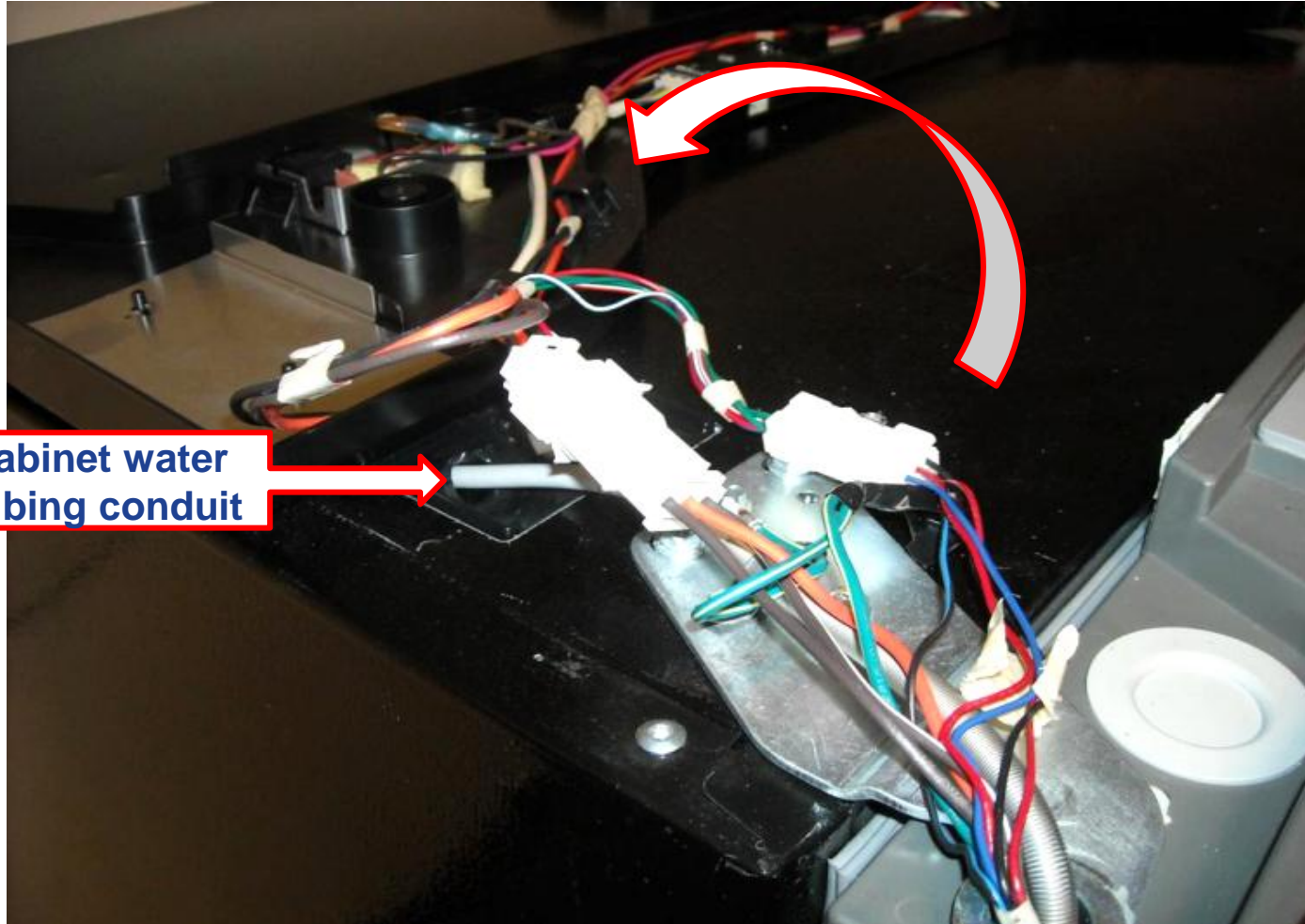

**Cabinet water  
tubing conduit**

# Disconnect the Water Line

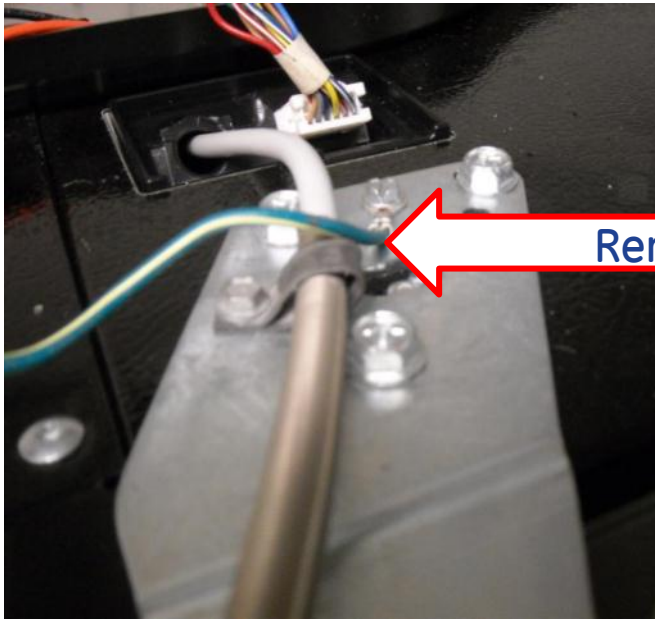

Remove the tube clamp from the hinge

Disconnect the top side of the quick connector located at the rear of the cabinet, 15" down from the top.

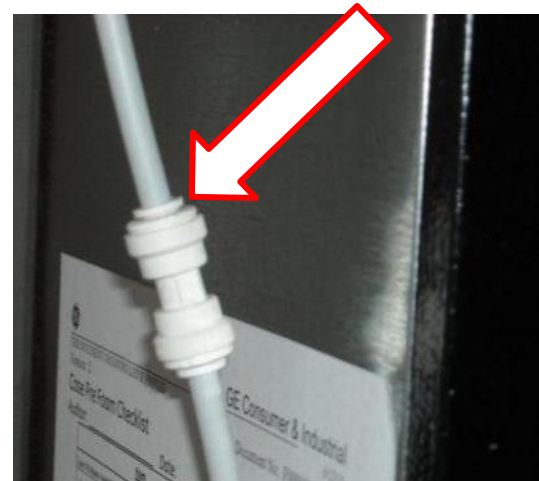

# Door Removal

- Pull the water line from the cabinet conduit.
- Disconnect the wiring connectors and ground wire.
- Remove the three 3/8" screws from the top hinge.
- Lift the hinge bracket up to release and remove from the door.

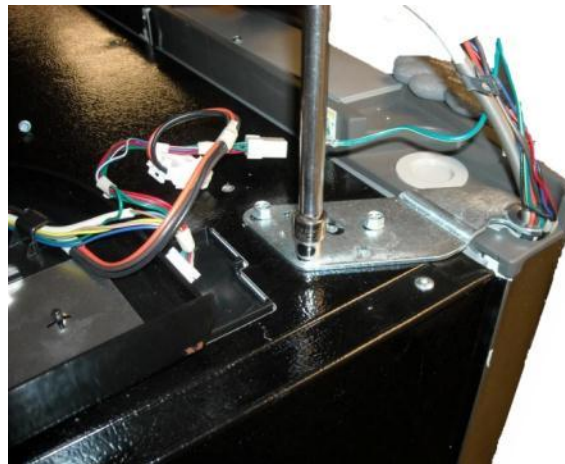
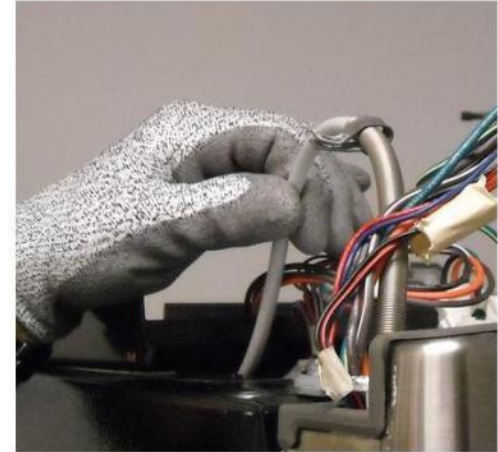

# Door Removal

Open the door to a 90 degree angle from the case and lift to remove the door from the lower hinge bracket.



# Fresh Food Door Stop

The door stop is held in place by two **T20** screws

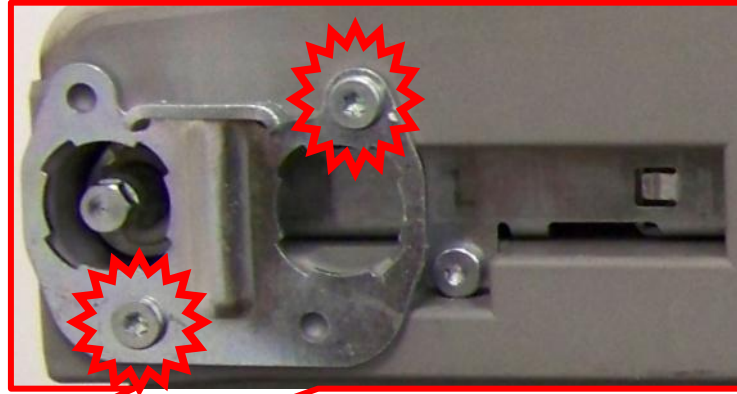

# Fresh Food Door Closer

The door closer is removed by first removing the door stop, then the **T20** mounting screw.





# Fresh Food Door Hinge and Closer

- The door closer has a spring loaded pin
- The right hinge bracket mounted to the case has an adjustable  $\frac{1}{4}$ " set screw so the fresh food doors can be leveled
- If the left door needs to be raised, shims will be available as a service part

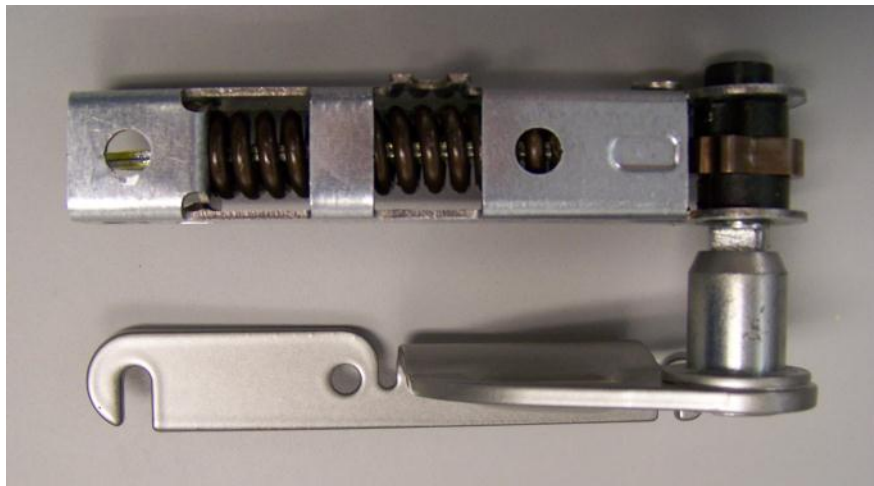

# Freezer LED Lighting

- Two LEDs located in the bottom of the LEFT fresh food door illuminate the interior of the freezer when the freezer drawer is opened.
- The LEDs are snapped into a bracket that is accessed by removing a **T20** screw.



# Articulating Mullion

- The articulating mullion is mounted to the left fresh food door
- The mullion uses a 12 VDC heater operated by the door control board.
- Operation is based on room temperature and humidity.

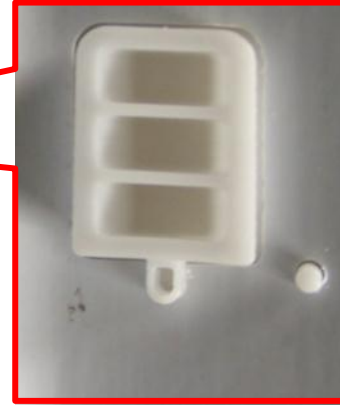

# Room Ambient Thermistor

The room air thermistor is located in the cover on the top of the cabinet, this thermistor is used to set the duty time of the sweat heaters and adjust the cooling system based on room temperature.

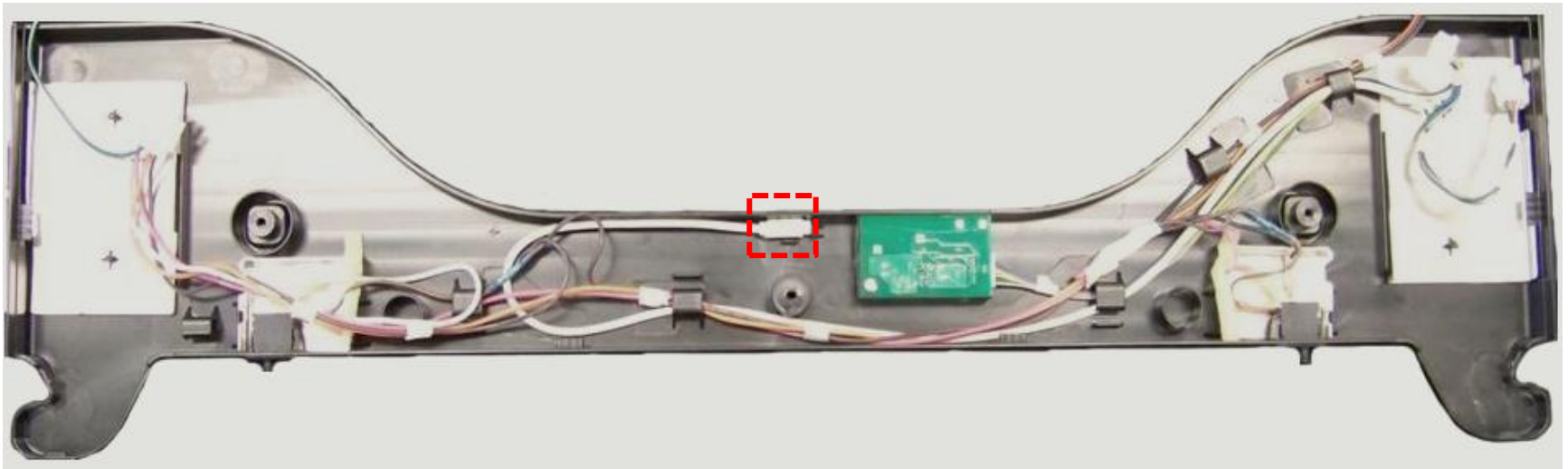

# RJ45, Ambient Thermistor and Humidity Board

The 'Zigbee™' board is located on the top of the case in the hinge cover. It contains the sensor to monitor the humidity level of the room and the RJ45 connector for computer diagnostics.

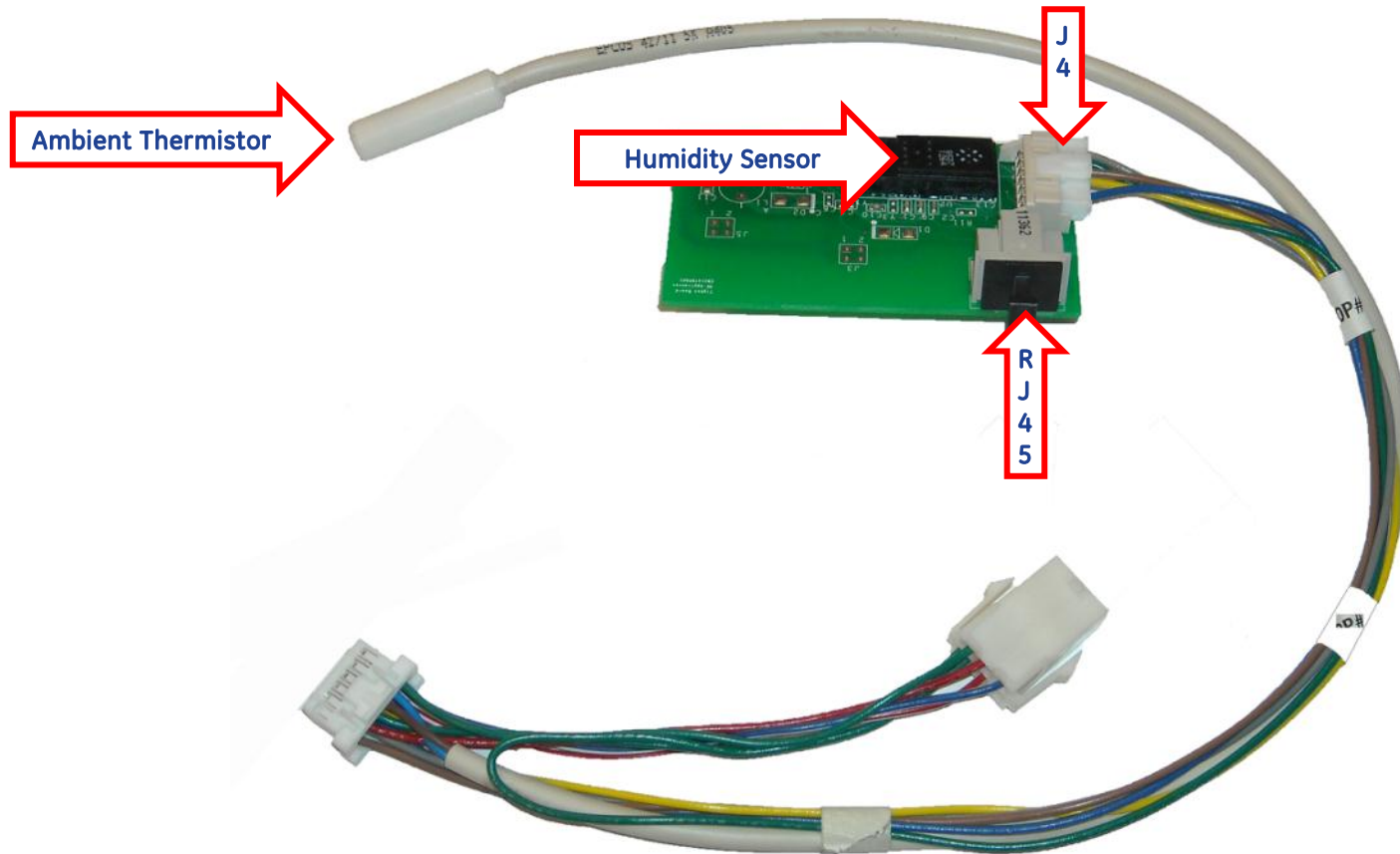

# Fresh Food Cabinet Interior



# Fresh Food Cabinet Interior PFE29

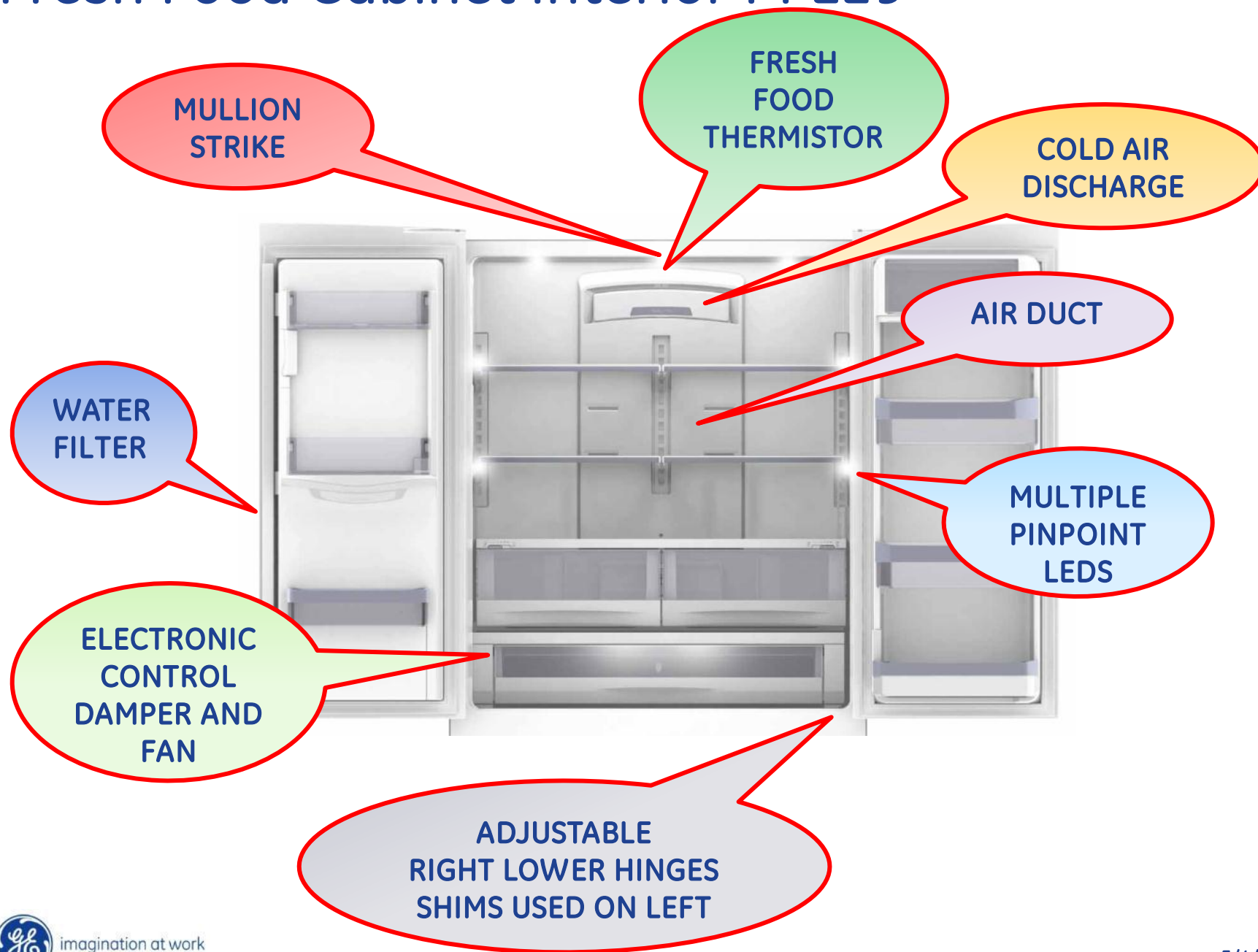

# Fresh Food Cabinet Interior GFE29

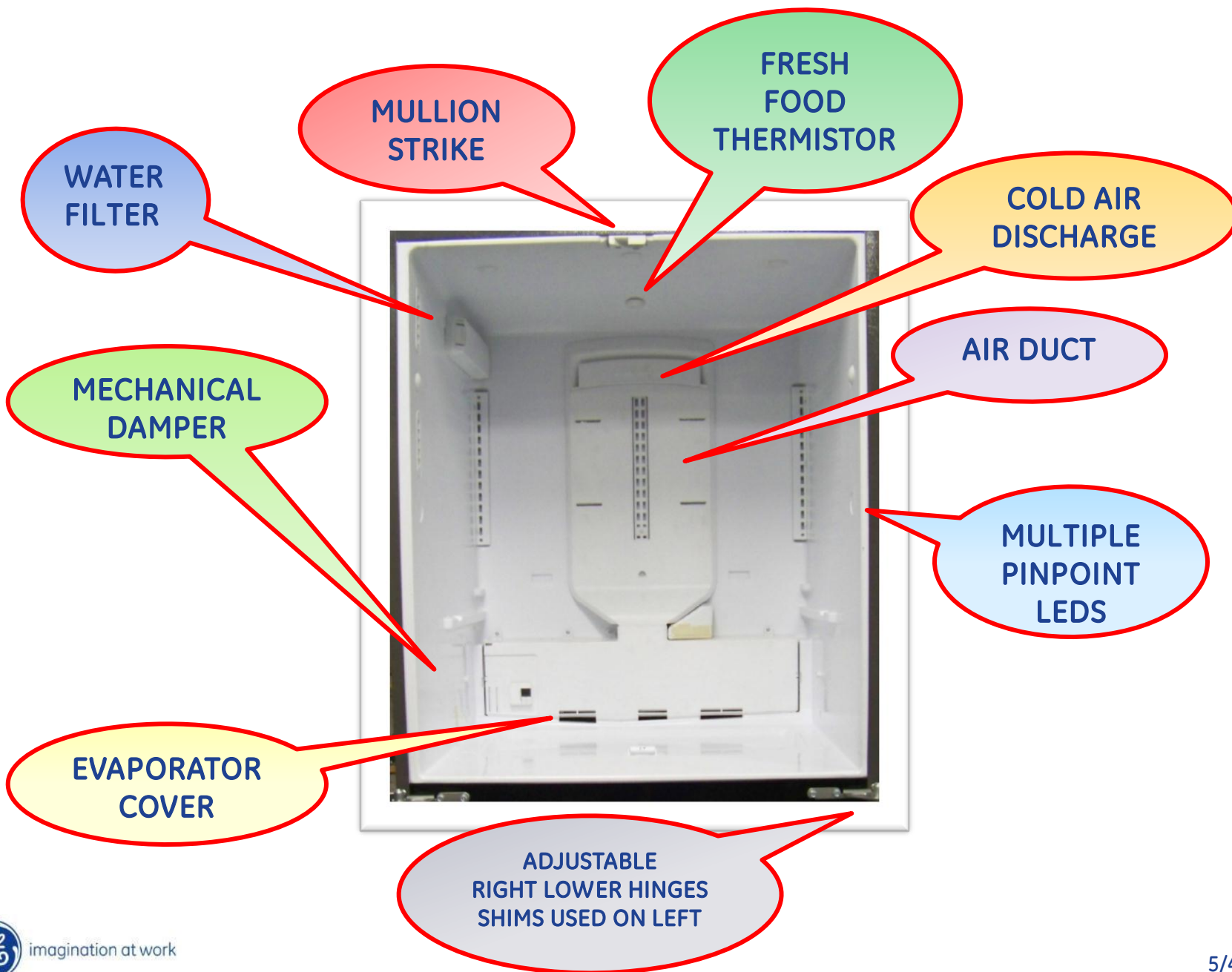



# Fresh Food Showcase Pin-Point LEDs



- The Pin-Point LEDs are in either a 5 or 7 LED series circuit.
- If one LED fails (but the LED's resistor is still OK), that LED will not be lit while the others will be dim.
- When one LED fails completely, none of the LEDs will light.
- With a voltmeter, 5VDC – 20VDC can be read across the terminals of the completely failed LED assembly.
- To remove the LED, pry up at the rear and slide to rear to release the tab.
- Each LED has a 2-pin connector for easy replacement.

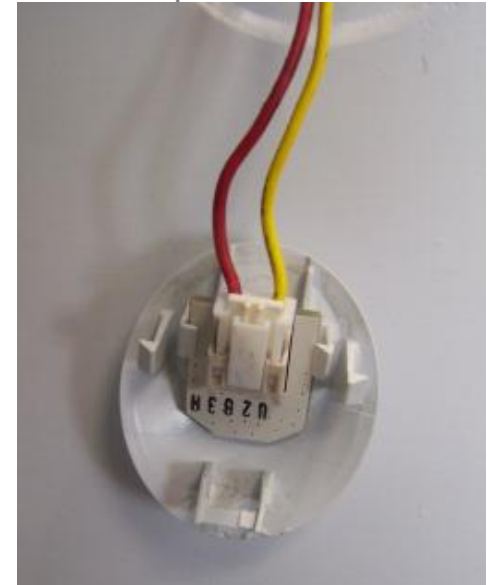
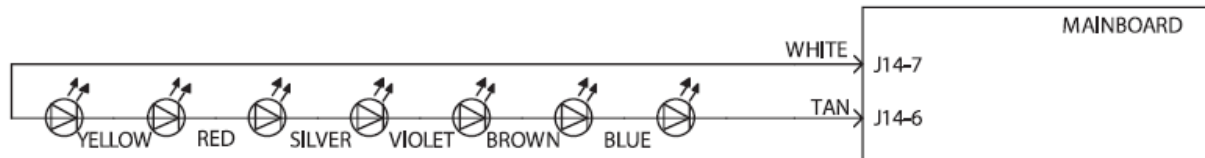

# Air Flow

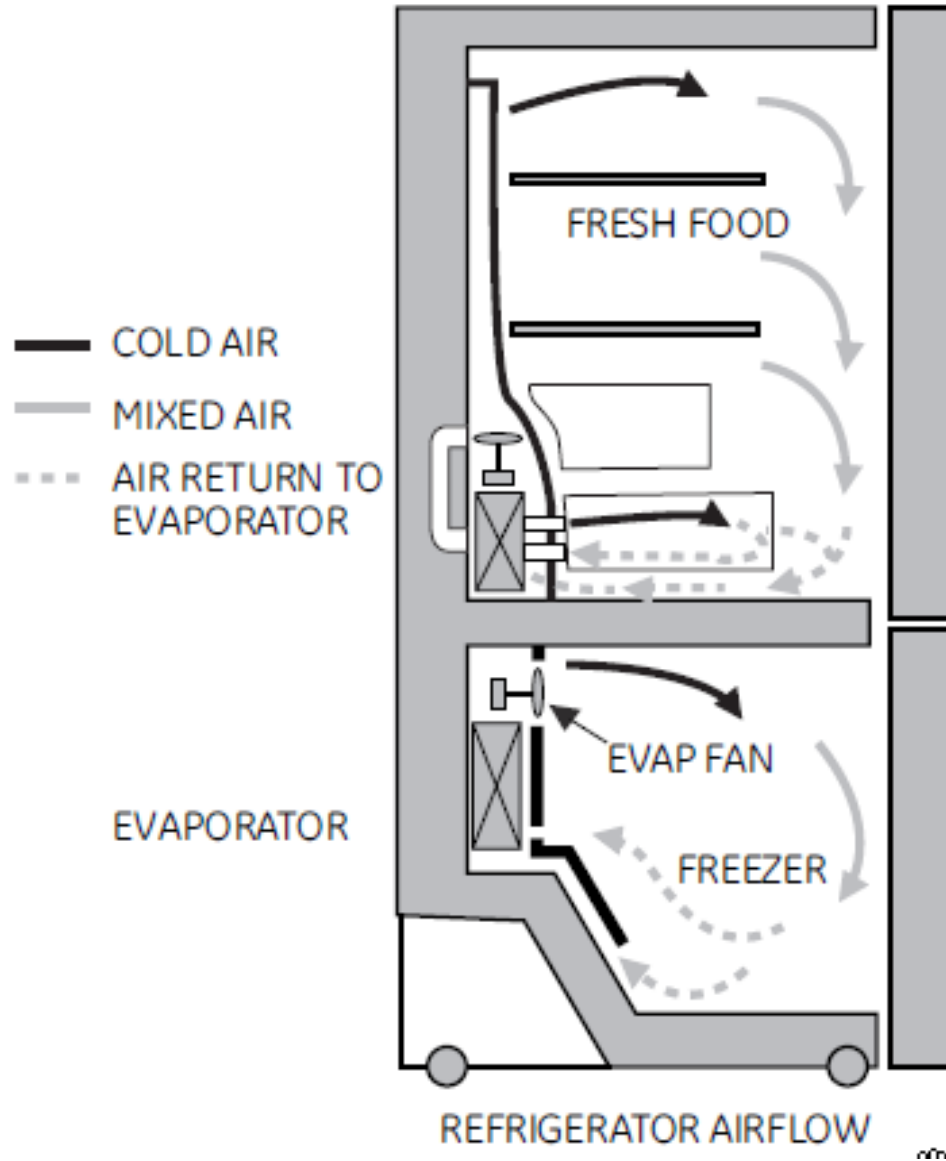

# Fresh Food and Freezer Thermistors

The Fresh Food thermistor is located in the ceiling and the freezer thermistor is located on the right hand side wall.

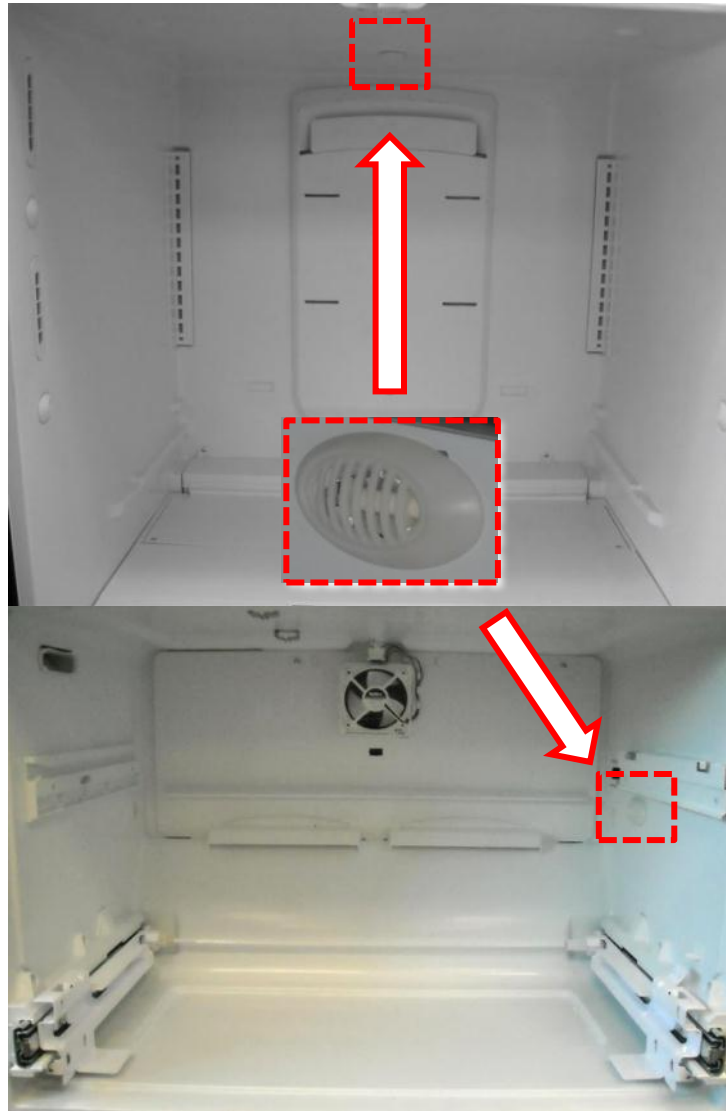

Thermistor Resistance		
Temperature (°F)	Temperature (°C)	Resistance in Kilo-Ohms
-40	-40	166.8 kΩ
-31	-35	120.5 kΩ
-22	-30	88 kΩ
-13	-25	65 kΩ
-4	-20	48.4 kΩ
5	-15	36.4 kΩ
14	-10	27.6 kΩ
23	-5	21 kΩ
32	0	16.3 kΩ
41	5	12.7 kΩ
50	10	10 kΩ
59	15	7.8 kΩ
68	20	6.2 kΩ
77	25	5 kΩ
86	30	4 kΩ
95	35	3.2 kΩ
104	40	2.6 kΩ
113	45	2.2 kΩ
122	50	1.8 kΩ
131	55	1.5 kΩ
140	60	1.2 kΩ

# Thermistor Replacement

The thermistor grille uses an alignment tab to ensure proper grille placement. The grille also uses two snap tabs to lock it into the liner.

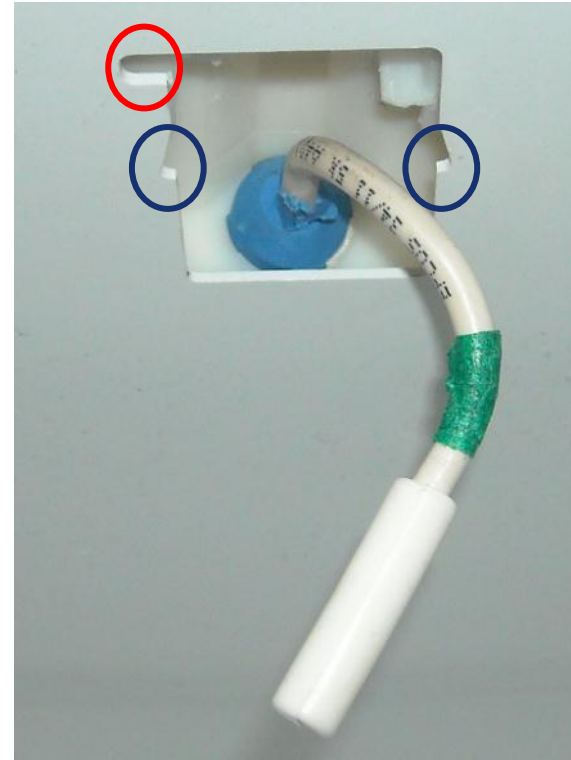

# Thermistor Replacement

To replace the air thermistor; remove the thermistor from the grille and cut the thermistor wiring as close to the thermistor as possible.

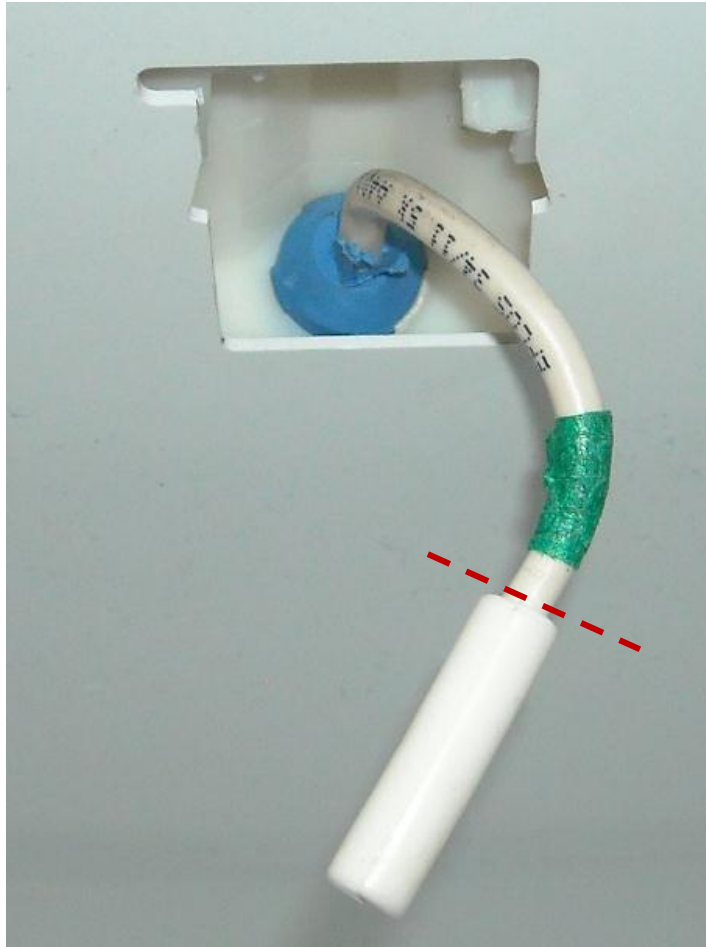

Strip the outer insulation from the thermistor case harness back 1". Strip the two internal wires back 3/16" for splicing.

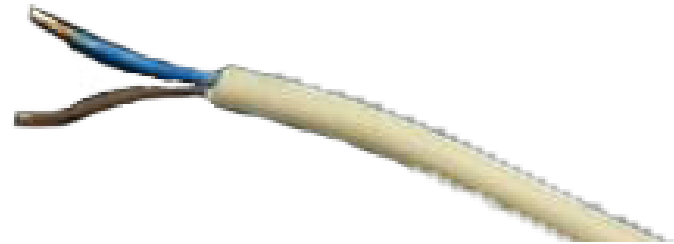

**GE Factory Service Technicians are required to always wear cut resistant gloves prior to commencing the repair.**

# Thermistor Splicing

Prepare the replacement thermistor (WR55x10025) by cutting the wiring 4" back from the thermistor and strip the wires back 3/16". Using two WR01X10466, splice the wiring. After the splices are complete, fill the bell connectors fully with WR97X163 silicone grease.

*Note: Service kit coming with heat seal connectors*



# Thermistor Splicing

Snap the thermistor into the grill and place excess wiring into the thermistor pocket, then snap the grille back into the liner taking note of the **alignment pin**.

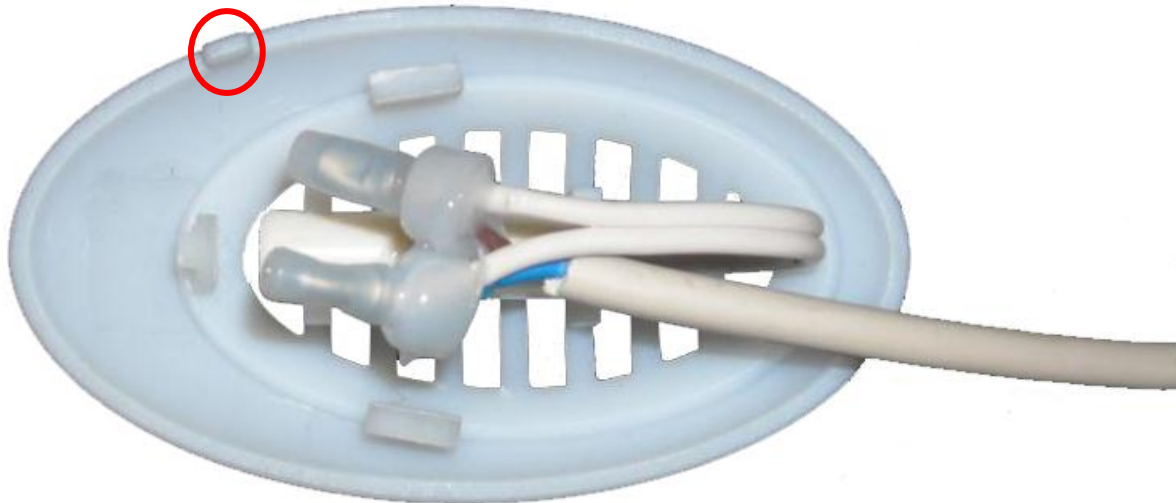

# Fresh Food Fan Testing

- The fresh food fan is located at the base of the fresh food air duct.
- The fresh food evaporator cover must be removed to access the fan, but can easily be checked at the electrical connector.
- Remove the right vegetable bin. Removing the electrical cover (A) will expose the electrical connector (B) for testing with a multi-meter.
- The fresh food fan operates at 3 speeds

1. LOW SPEED = 2700 RPM\*
2. MEDIUM SPEED = 3000 RPM\*
3. HIGH SPEED = 3300 RPM\*

Note: Fan speed range of 1500–4100 RPM is acceptable

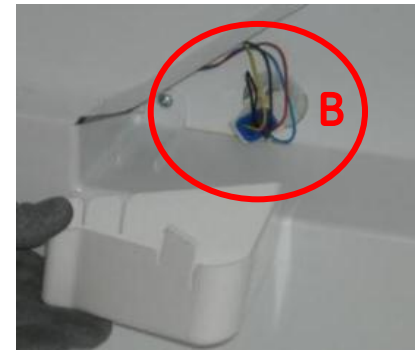
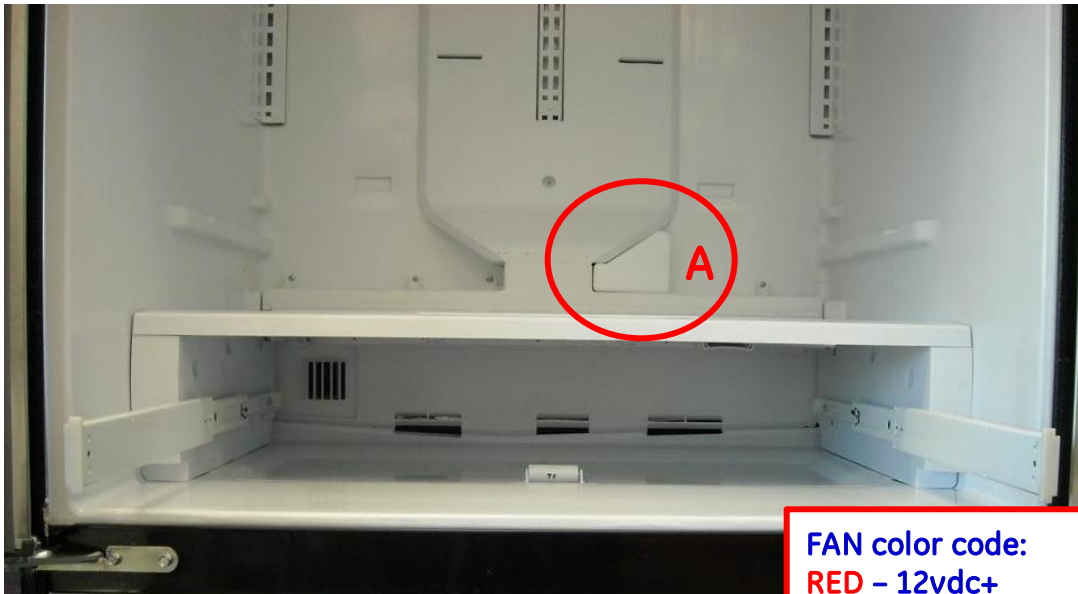

FAN color code:  
RED - 12vdc+  
BLACK - 12 VDC-  
YELLOW - PWM SPEED  
BLUE - RPM FEEDBACK

\* Values are approximate and preliminary



# Deli Pan Cover Removal

- Remove both vegetable bins and deli pan. It is not necessary to remove the upper glass shelves.
- Remove the Phillips screw on each side of the deli pan cover.



# Deli Pan Cover Removal

- Slide the front part of the deli pan cover forward
- Disconnect the electrical connector at the left slide assembly

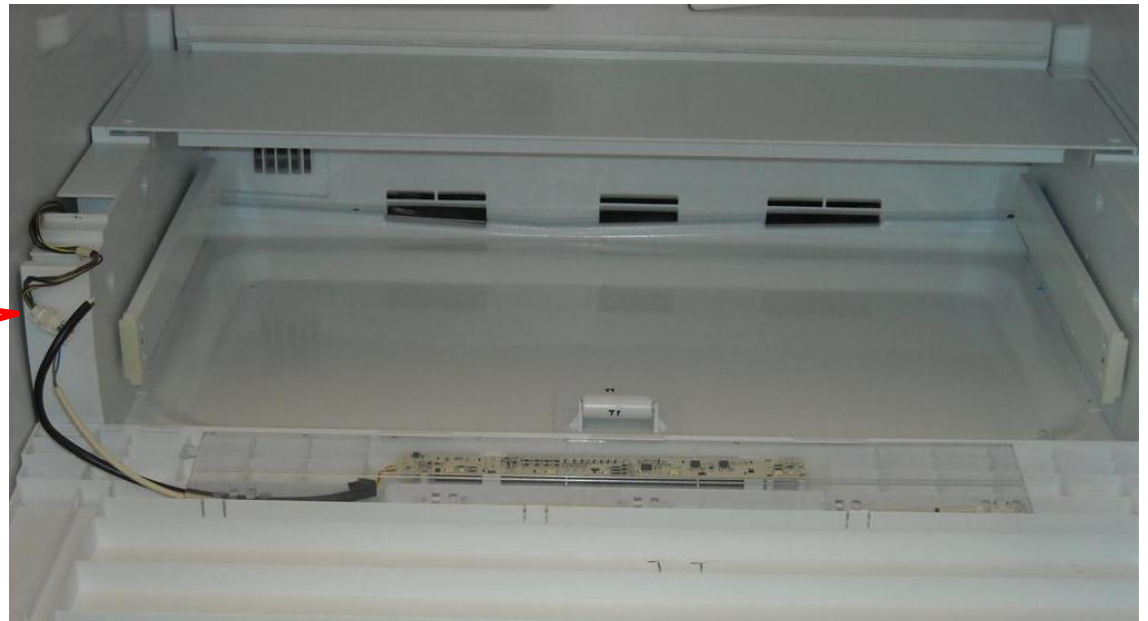

# Deli Pan Board On Cover

- The deli pan board sends the customer setting to the main board to control the pan temperatures based on the deli thermistor value.
- Temperature is controlled by opening or closing the deli damper, varying fan speeds and turning on a 5 watt heater as needed.
- The consumer presses a single button (tactile switch) to scroll through the settings.
- LEDs on the control will light the selected mode. White LEDs will also light the pan area. Colored LEDs will light the pan area on the Café models.

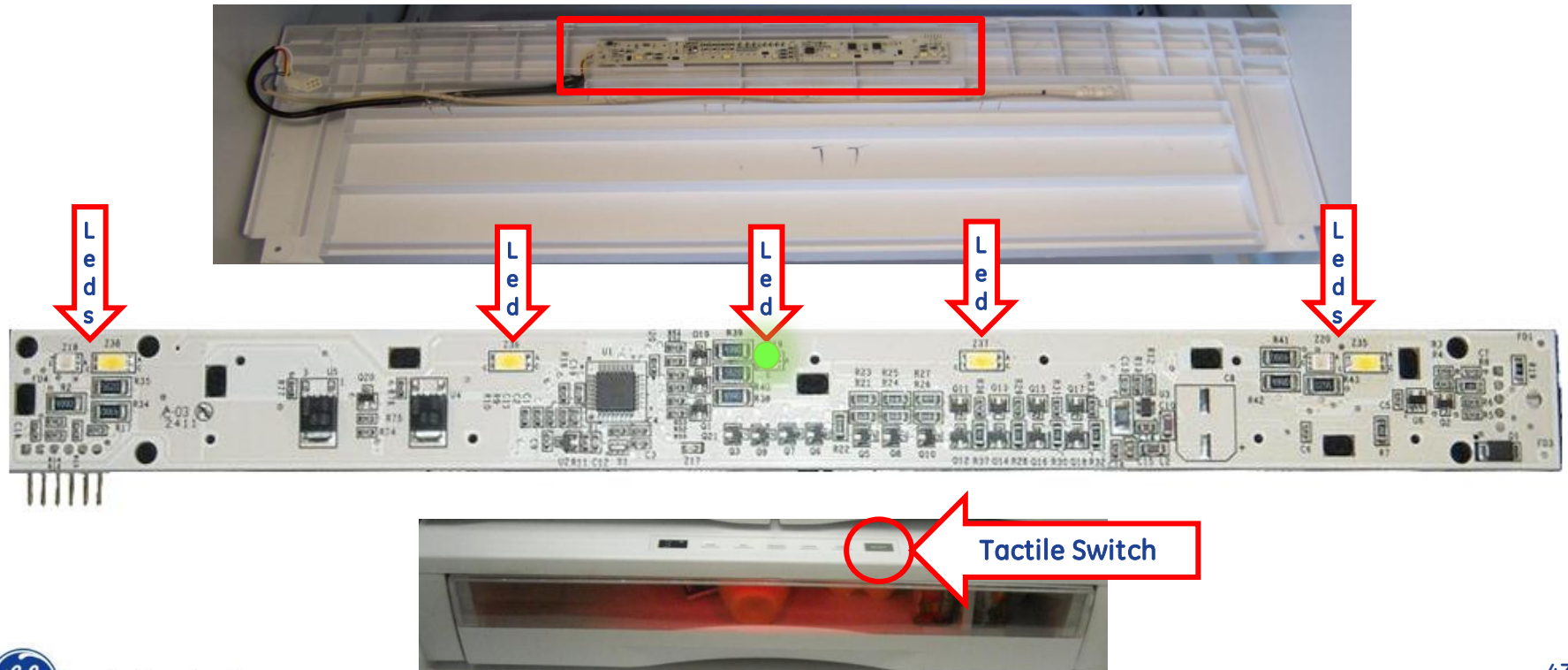

# Deli Pan Set Points

FF Set Point					
46	OFF	OFF	OFF	OFF	ON
45	OFF	OFF	OFF	OFF	ON
44	OFF	OFF	OFF	ON	ON
43	OFF	OFF	OFF	ON	ON
42	OFF	OFF	ON	ON	ON
41	OFF	OFF	ON	ON	ON
40	OFF	ON	ON	ON	ON
39	OFF	ON	ON	ON	ON
38	ON	ON	ON	ON	ON
37	ON	ON	ON	ON	ON
36	ON	ON	ON	ON	ON
35	ON	ON	ON	ON	ON
34	ON	ON	ON	ON	ON
<b>DP Setting</b>	<b>Meat</b>	<b>Deli</b>	<b>Produce</b>	<b>Cheese</b>	<b>Citrus</b>
	<b>32</b>	<b>34</b>	<b>36</b>	<b>38</b>	<b>40</b>

**Table 13: Deli Pan Selectable Modes depending on FF Set Point**

The selections that show 'OFF' are not available at the fresh food set points on the left. Example is meat is not available when fresh food temp is set to 39°F or higher.

# Deli Pan Thermistor

Thermistor Resistance		
Temperature (°F)	Temperature (°C)	Resistance in Kilo-Ohms
-40	-40	166.8 kΩ
-31	-35	120.5 kΩ
-22	-30	88 kΩ
-13	-25	65 kΩ
-4	-20	48.4 kΩ
5	-15	36.4 kΩ
14	-10	27.6 kΩ
23	-5	21 kΩ
32	0	16.3 kΩ
41	5	12.7 kΩ
50	10	10 kΩ
59	15	7.8 kΩ
68	20	6.2 kΩ
77	25	5 kΩ
86	30	4 kΩ
95	35	3.2 kΩ
104	40	2.6 kΩ
113	45	2.2 kΩ
122	50	1.8 kΩ
131	55	1.5 kΩ
140	60	1.2 kΩ

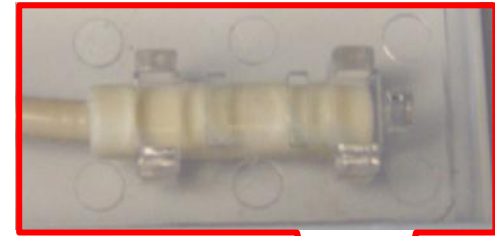

# Deli Pan Slide Removal

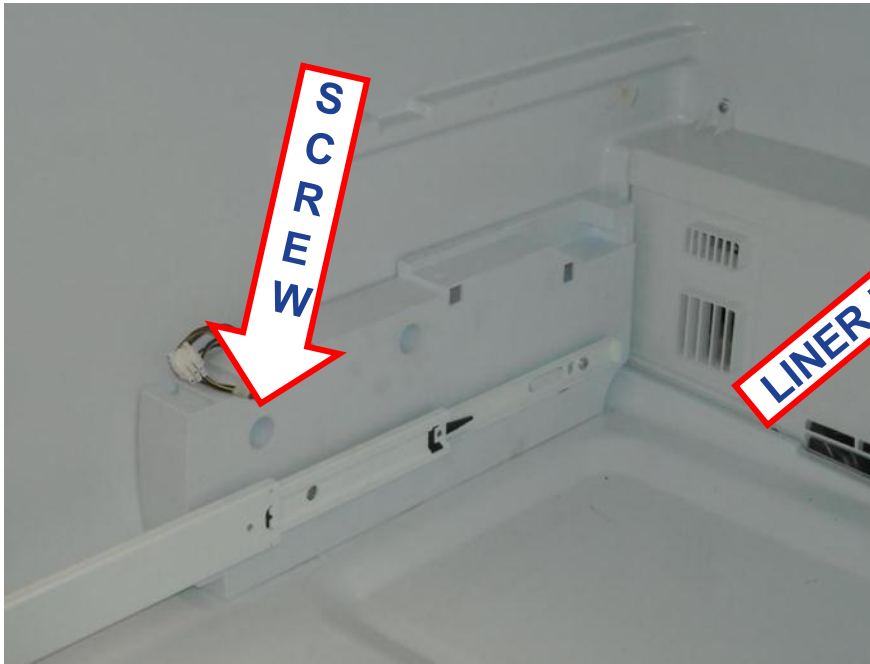

- Remove the screws from both of the deli pan slide assemblies.
- Pull the assembly forward to disengage the tab from the wall liner post.

# Mechanical Deli Damper (GFE29 only)

- The mechanical deli damper is also located on the fresh food evaporator cover and is accessed the same way.
- The damper is operated by a lever in the left slide assembly.
- Moving the lever up closes the damper while moving it down opens it.

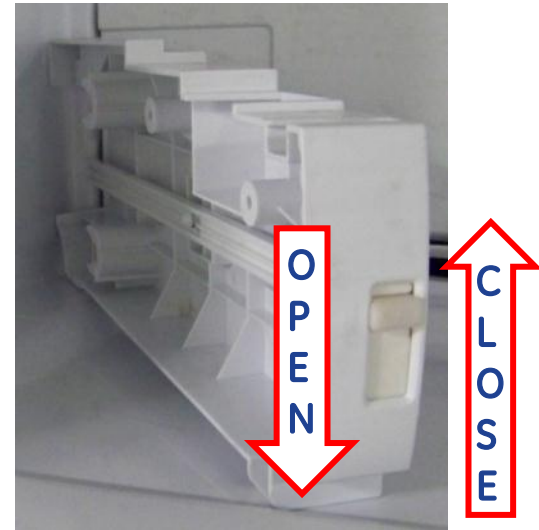
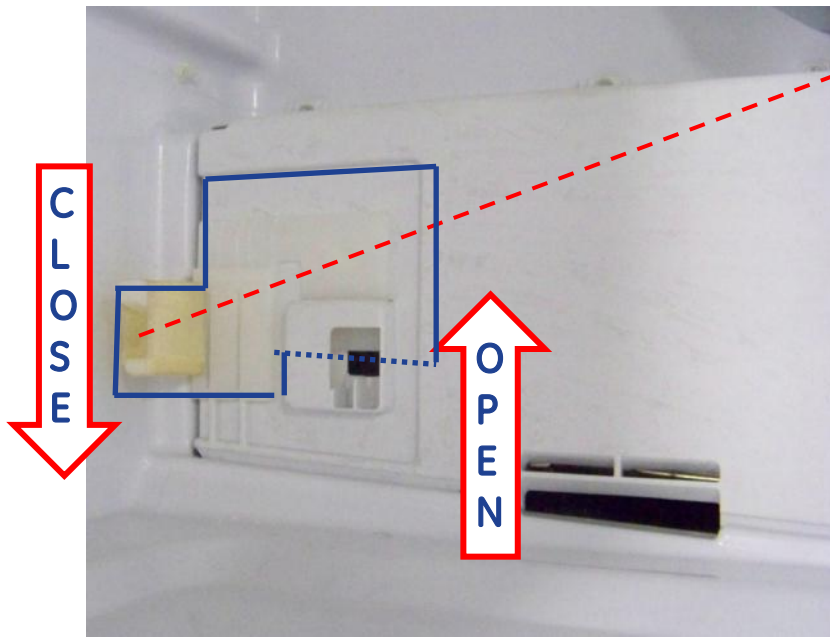

# Fresh Food Evaporator Cover

- Remove the fresh food fan connector cover by pressing down at the upper right, then slide it straight out.
- Remove 5 Phillips screws. 1 screw is behind the connector cover.

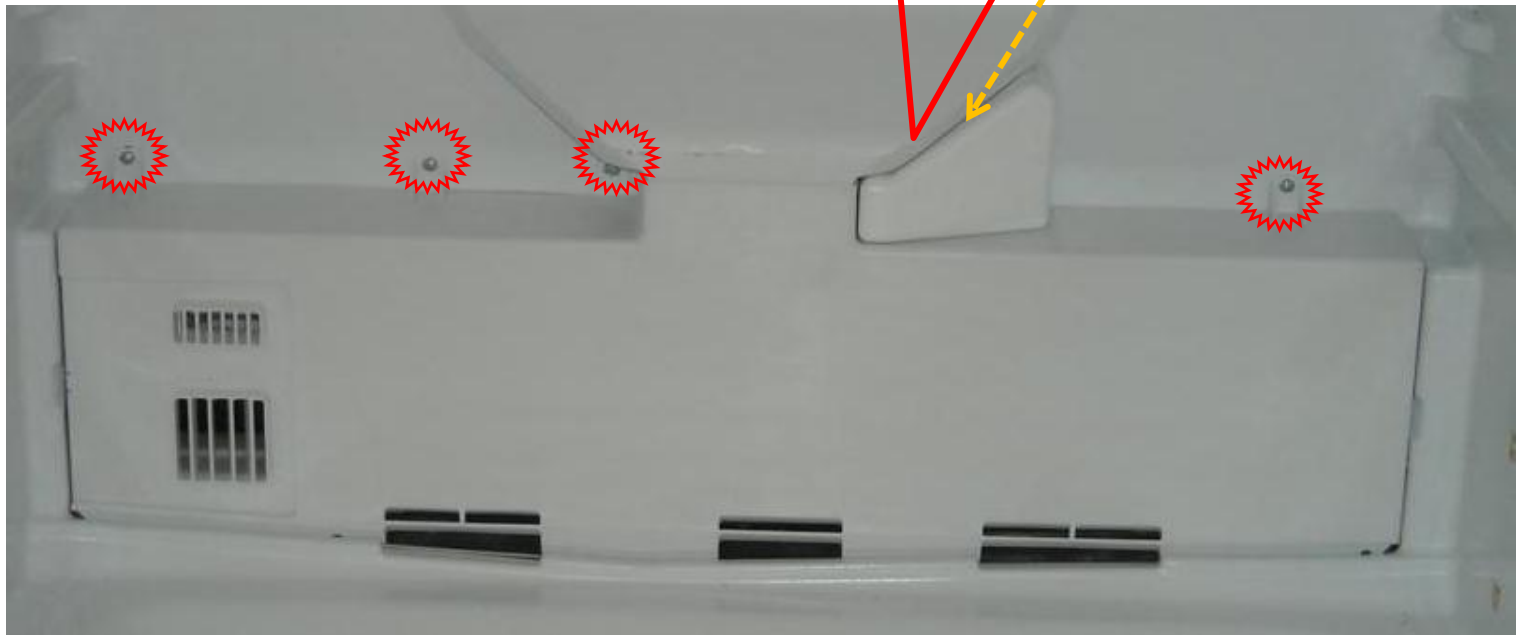
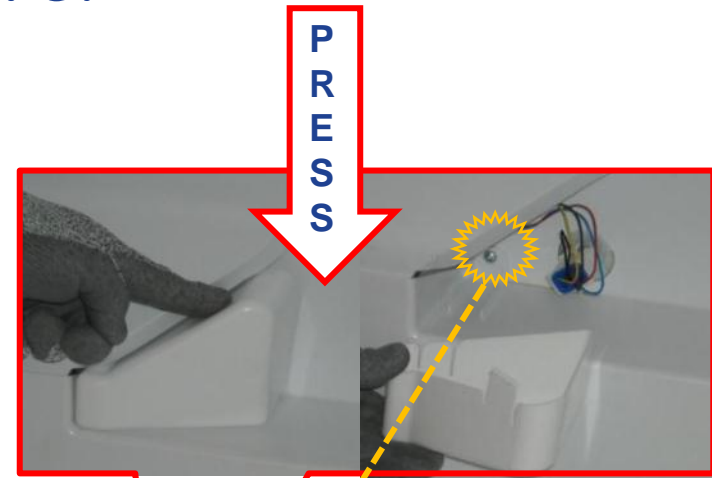



# Deli Pan Fan, Heater and Damper

- Pull up on the fresh food evaporator cover and lay it forward.
- Disconnect the fan and damper assembly connector.
- Remove the gasket and Styrofoam retainer, then remove the assembly from the evaporator cover.

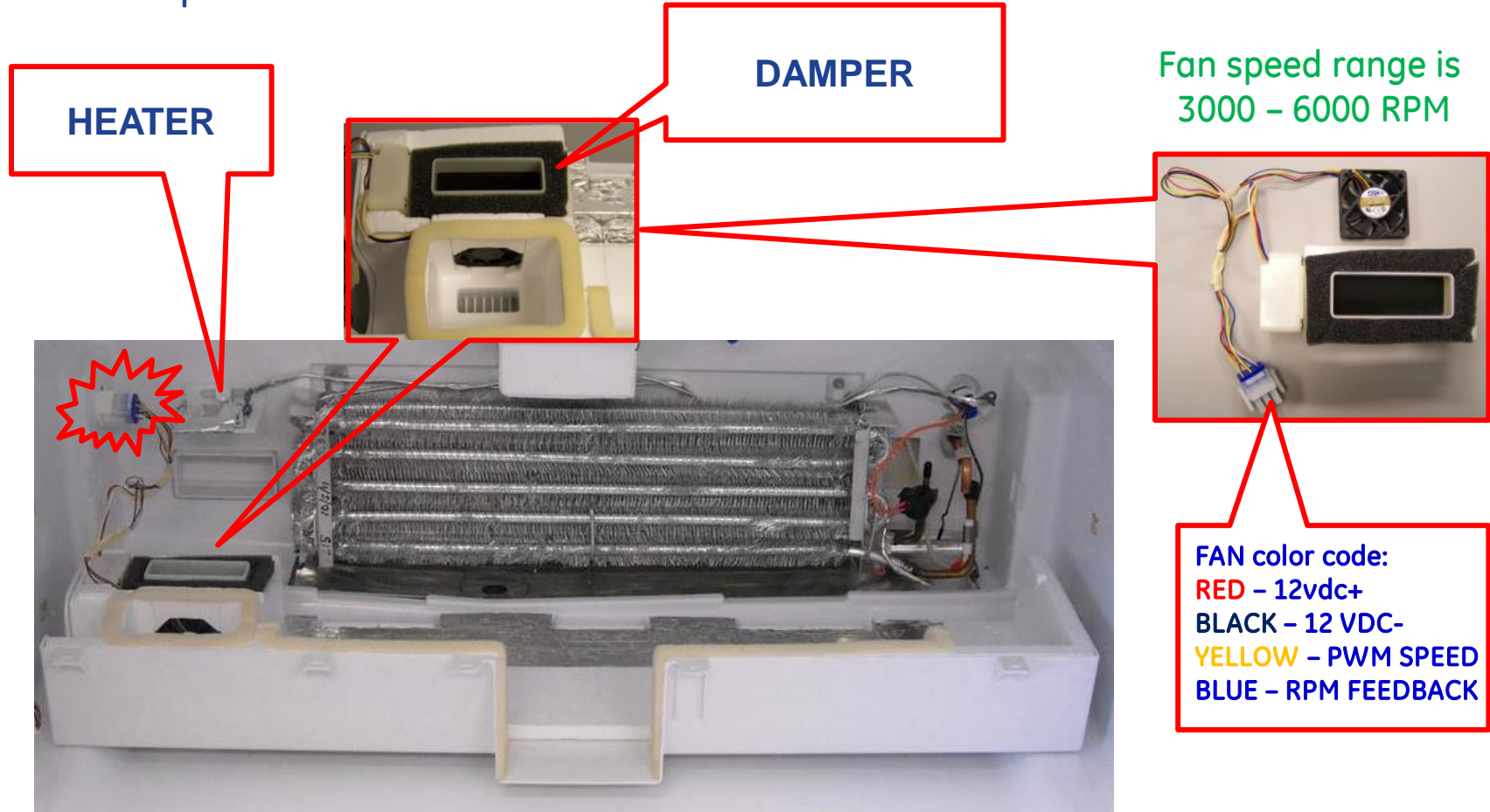

\* Values are approximate and preliminary

# Fresh Food Fan Removal

- Disconnect the motor harness connector.
- Pull the Styrofoam cover out from the lower left corner and remove.

FAN color code:  
RED - 12vdc+  
BLACK - 12 VDC-  
YELLOW - PWM SPEED  
BLUE - RPM FEEDBACK



- Slide the fan assembly forward and out of the fan mounting bracket.

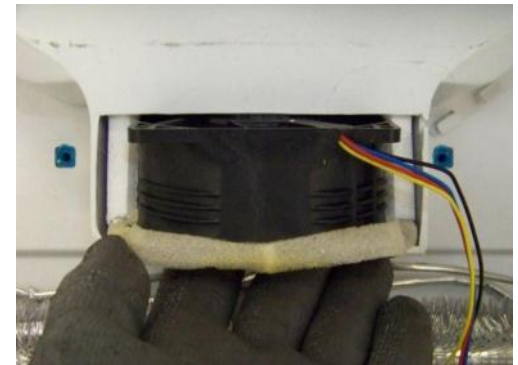

# Fresh Food Evaporator Thermistor

The fresh food evaporator thermistor is mounted to the suction line, its sole purpose is to monitor the evaporator temperature for defrost control.



# Fresh Food Defrost Heater



- The fresh food defrost heater is located at the bottom of the evaporator between the rows of coils, attached to the end plates.
- It is a 165 watt glass tube radiant heater.
- The heater can be dismantled by removing the center support. Bend the tabs on the end plates inward then pull it down and forward.
- There is a drip shield mounted just above the heater.
- There is a 140°F safety thermostat in the neutral line of the heater circuit.



*Note: The evaporator is shown inverted for illustration.*

Bend tab inward



# Freezer Interior

# Freezer Interior GFE29

ICEMAKER

FREEZER  
FAN

UPPER BASKET  
SLIDES

ICE BOX  
AIR  
RETURN

UPPER  
BASKET  
SLIDES

FREEZER  
THERMISTOR

LOWER  
BASKET  
SLIDES

LOWER  
BASKET  
SLIDES

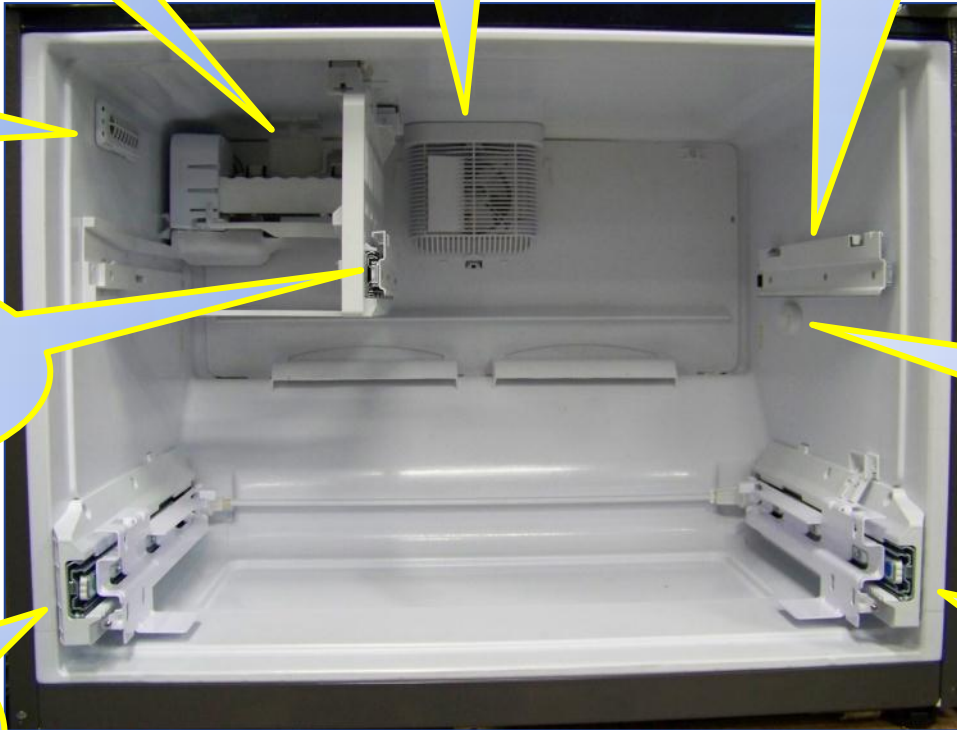

*Note: PFE29 interior is the same but  
does not have freezer icemaker*

# Freezer Drawer Removal

Open the drawer and remove three 3/8" screws from the left and right hand slides.

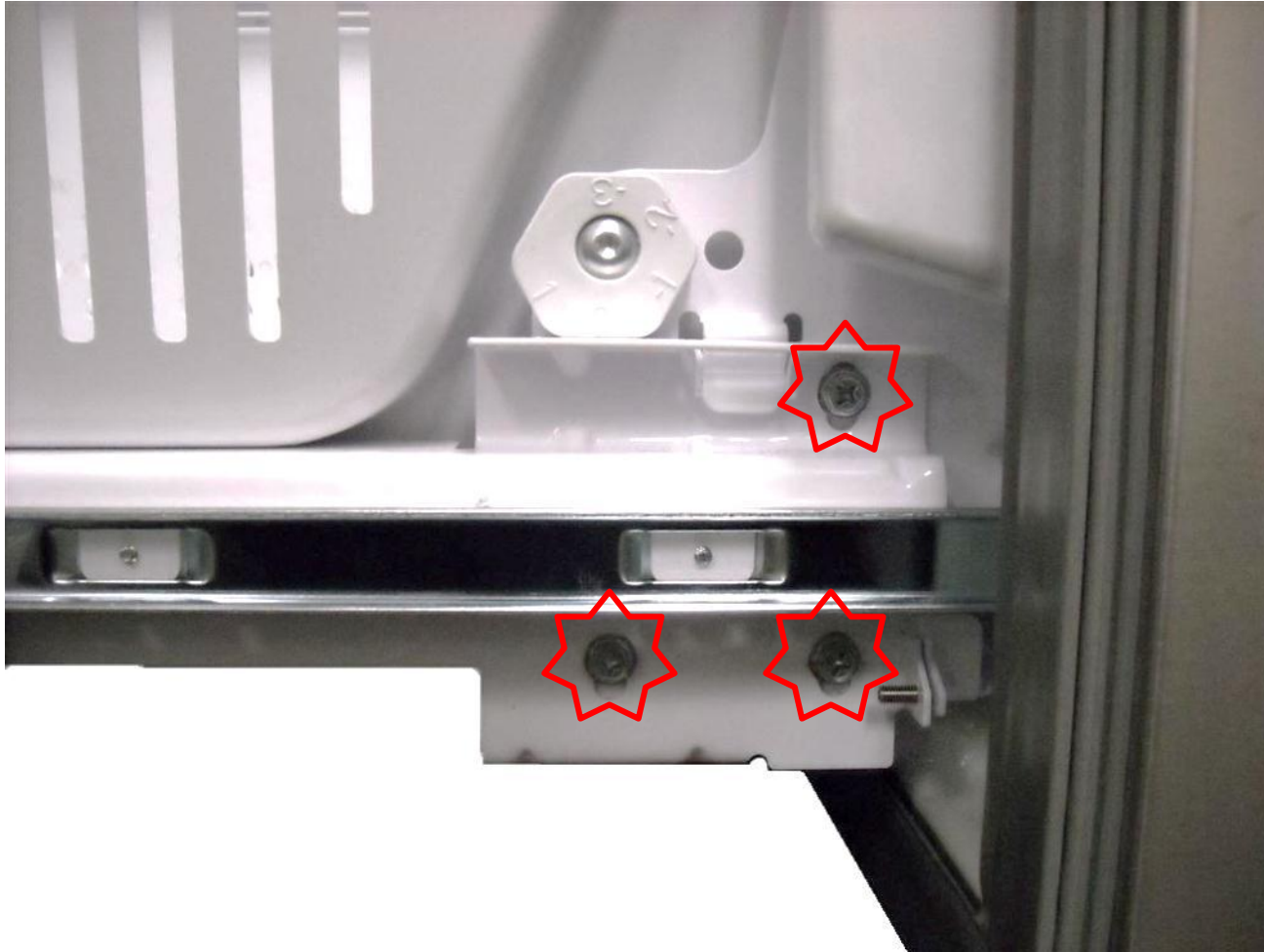

# Freezer Drawer Removal

Lift the drawer front off of the slides – releasing the two tabs from the slide tab slots.

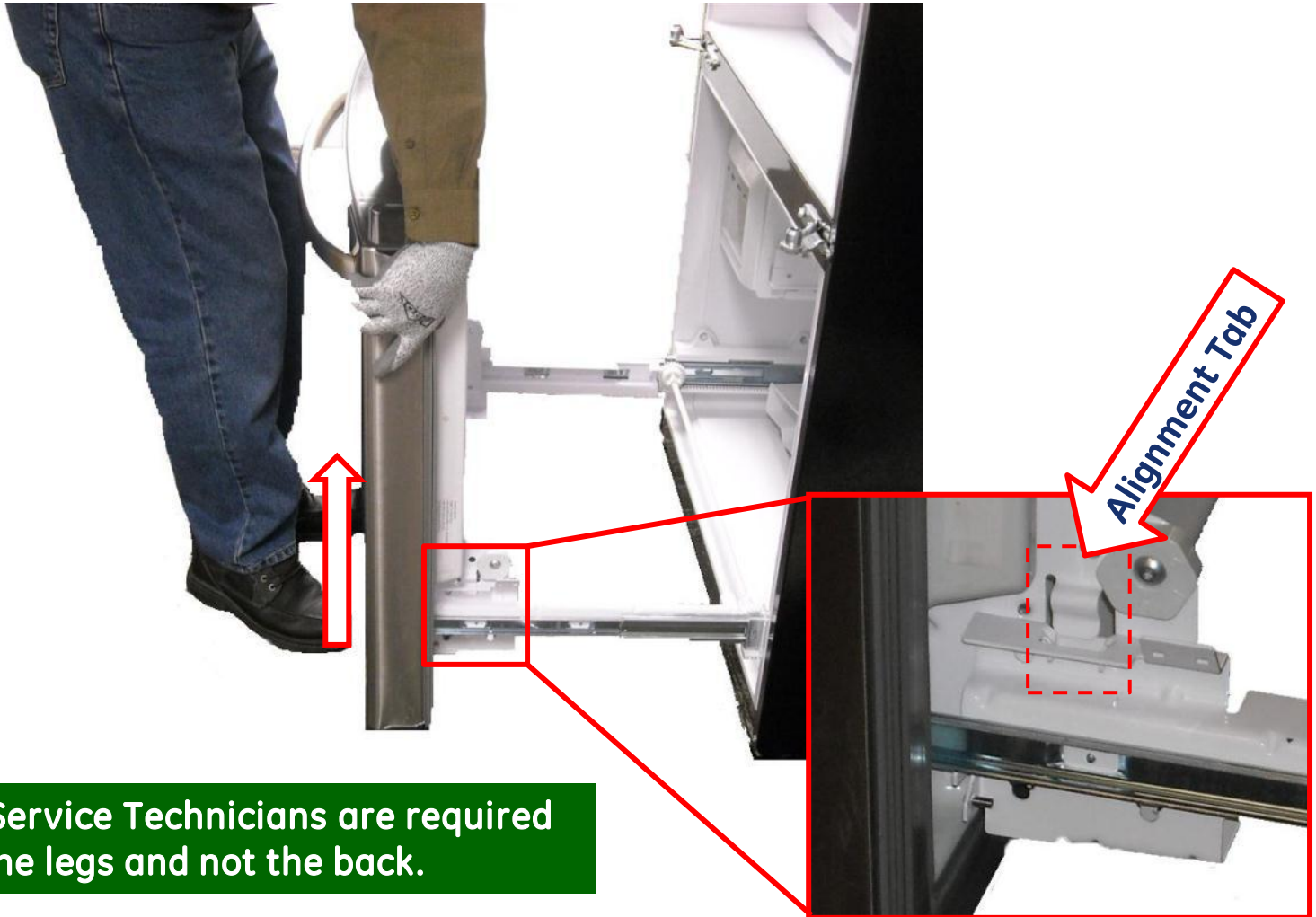

**GE Factory Service Technicians are required to lift with the legs and not the back.**



# Freezer Drawer Adjustment

The adjustment knob(s) can be rotated to change the horizontal drawer plane.



# Freezer Fan

- The freezer fan is mounted to the freezer evaporator cover and uses a grille to direct the air flow.
- The freezer fan will operate at 3 speeds with RPM feedback to the control:
- The fan connector can be accessed for multi-meter checks by removing only the grille.

1. LOW SPEED = 2200 RPM\*
  2. MEDIUM SPEED = 2400 RPM\*
  3. HIGH SPEED = 2500 RPM\*
- Note fan speed range is 1500 – 2900 RPM\*

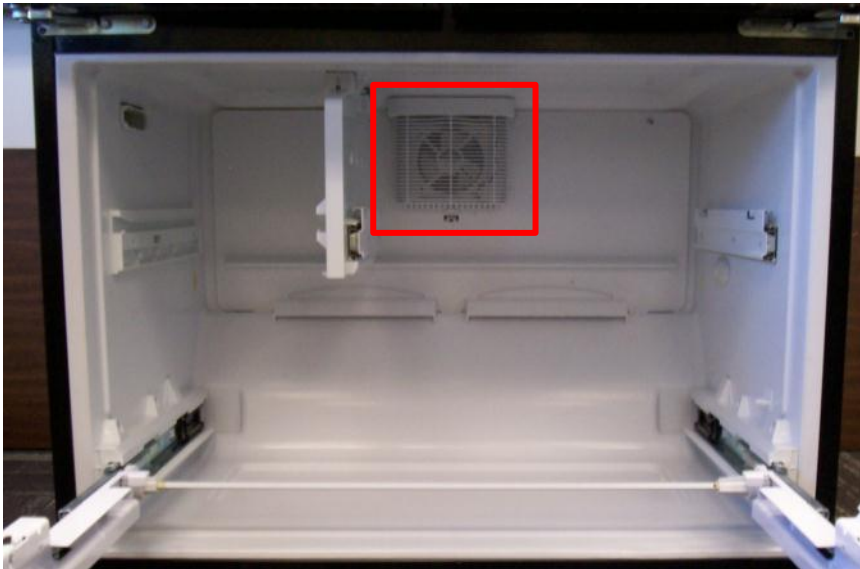

\* Values are approximate and preliminary

# Freezer Fan Grille Removal

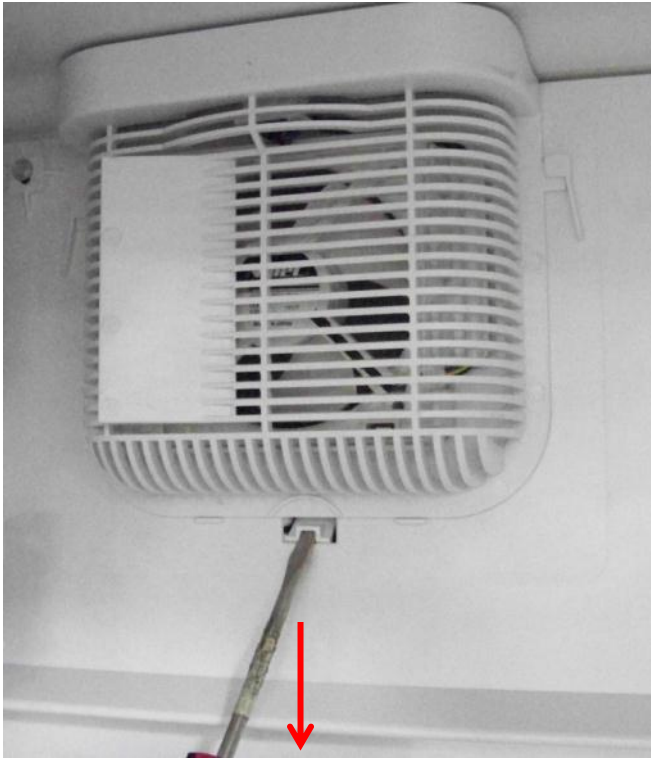

Insert a screwdriver into the slot and pry down to raise the tab and release the grille.

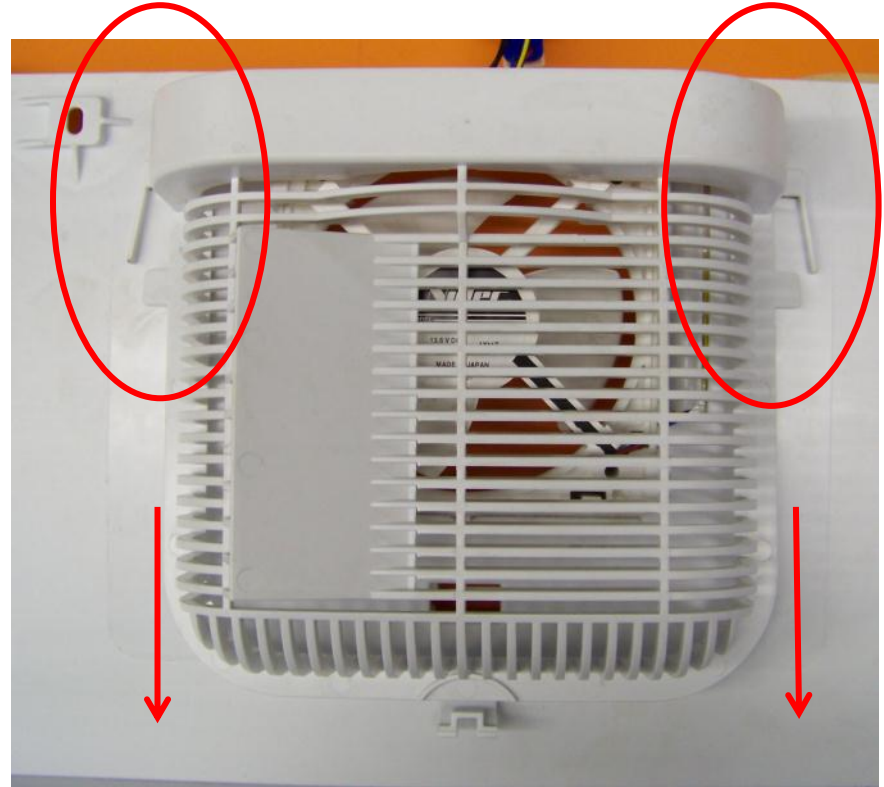

The grille will now slide down to disengage the top tabs.

# Freezer Fan Removal

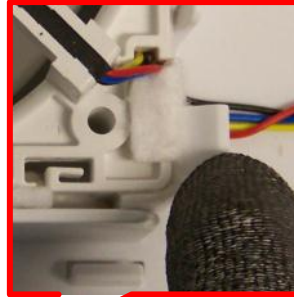

- Flex the tab at the lower right to release the fan from the evaporator cover.
- Slide the fan to the right to disengage the left retainer tabs.
- Disconnect the electrical connector.

# Ice Box Air Flow

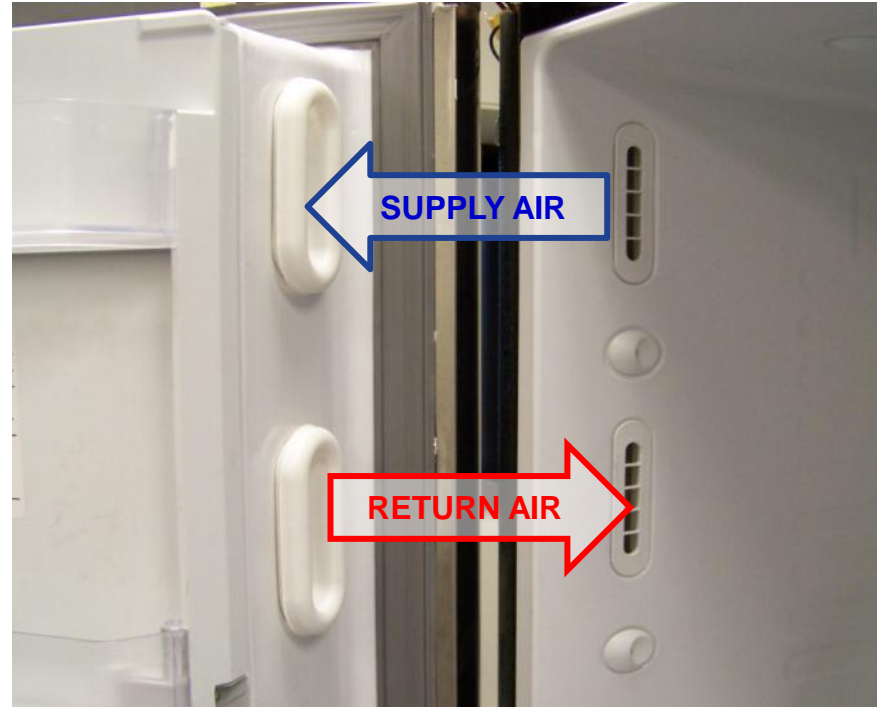
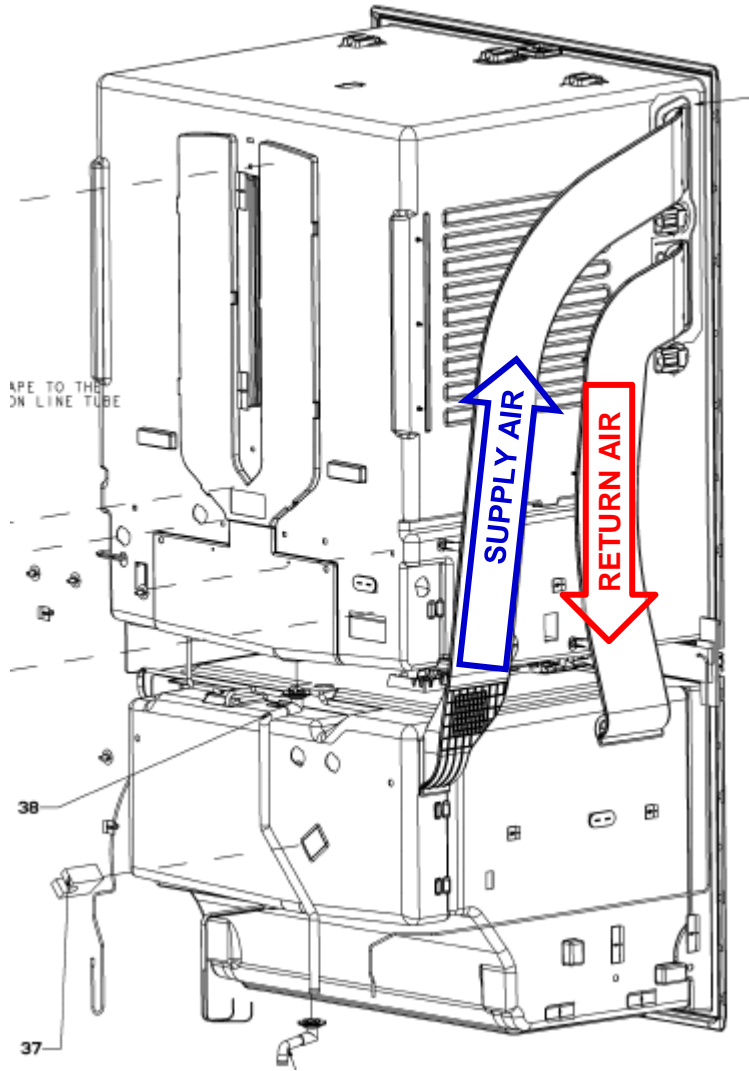

# Ice Box Fan

- The ice box fan is located at the top left rear of the freezer, above the evaporator.
- The ice box fan circulates air into the left fresh food door ice box via ductwork foamed into the case.
- The fan has 3 possible speeds, depending on the ice box cooling temperature and is controlled by the main board.

1. LOW SPEED = 1500 RPM\*
  2. MEDIUM SPEED = 1700 RPM\*
  3. HIGH SPEED = 1800 RPM\*
- Note fan speed range is 1000 – 2500 RPM\*

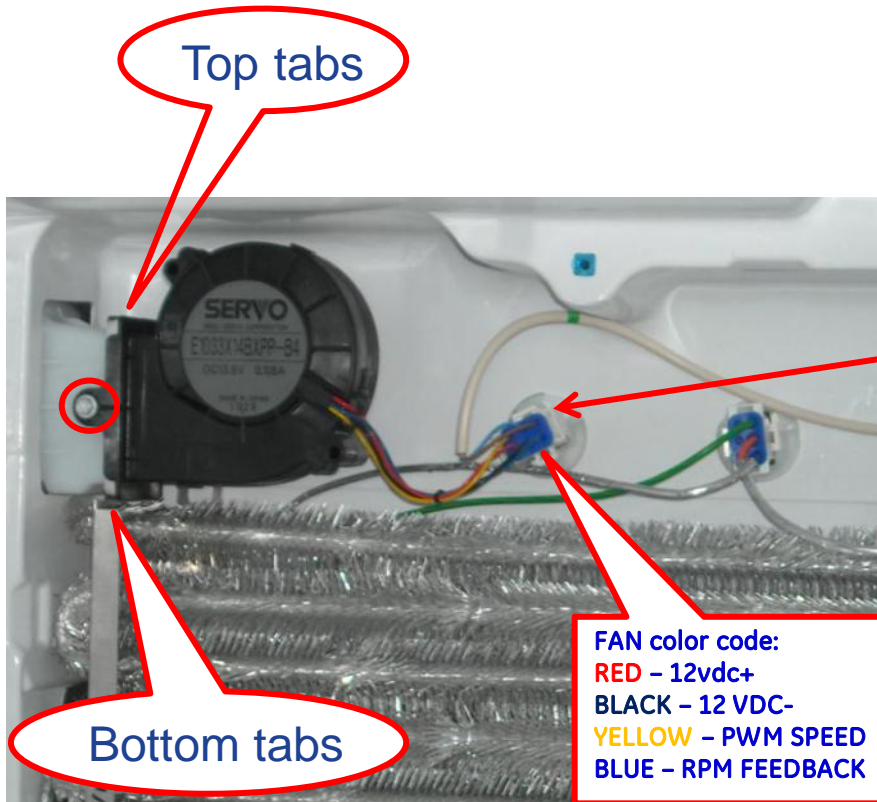

## Removal:

- Disconnect the electrical connector.  
*Note: This connector contains the freezer evaporator thermistor connections*
- Remove the 1/4" mounting screw.
- Gently flex the top or bottom tabs to release the fan from the ice box air supply duct.

\* Values are approximate and preliminary

# Ice Box Fan Removal

- The upper freezer compartment divider must be removed to access the evaporator cover.
- Remove the 2 retainers by flexing them outward and pulling toward the front to release.
- Slide the divider backward to disengage from the retainer mounted to the ceiling.

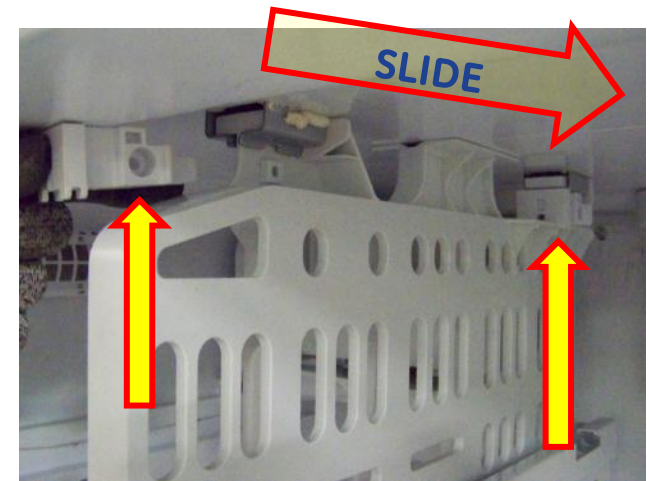
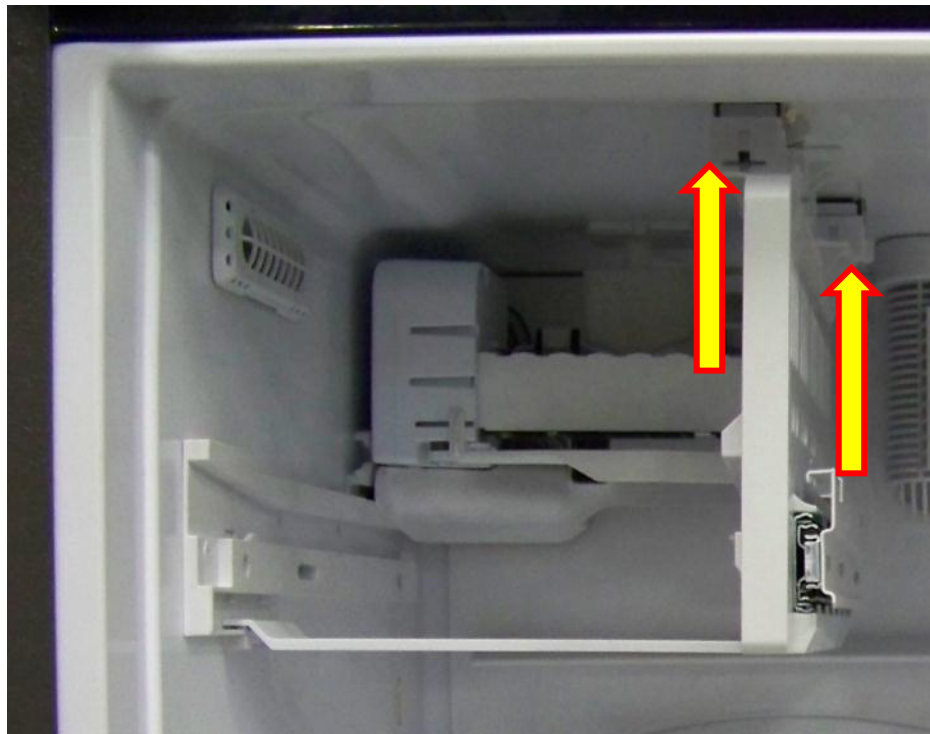
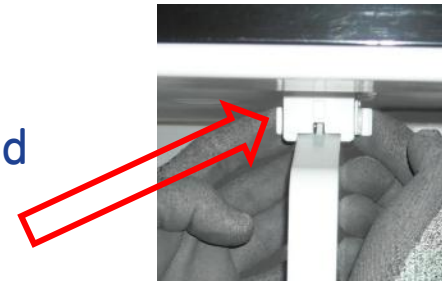

GFE29- icemaker must be removed (see icemaker removal)

# Evaporator Cover Removal



- Remove the 2 Phillips screws at the top of the evaporator cover.
- Push the cover up to release the tabs at the bottom, then pull the bottom outward.
- Disconnect the fan connector.



**NOTE:** *The freezer fan does not have to be removed from the cover*



# Evaporator and Ice Box Fan

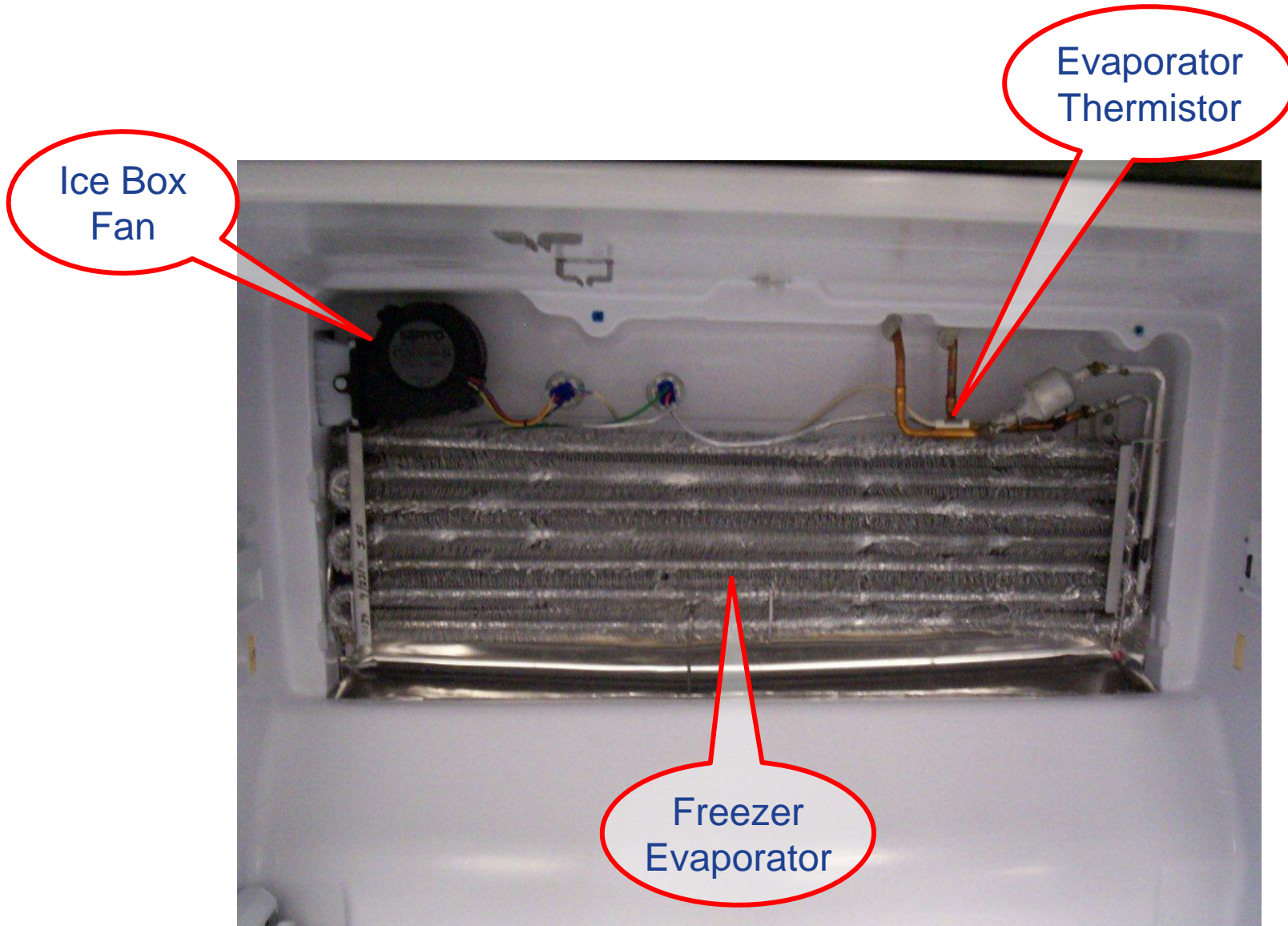

# Freezer Evaporator Thermistor

The freezer evaporator thermistor is mounted to the suction line. The purpose of the thermistor is to monitor the evaporator temperature for defrost control.



# Freezer Defrost Heater

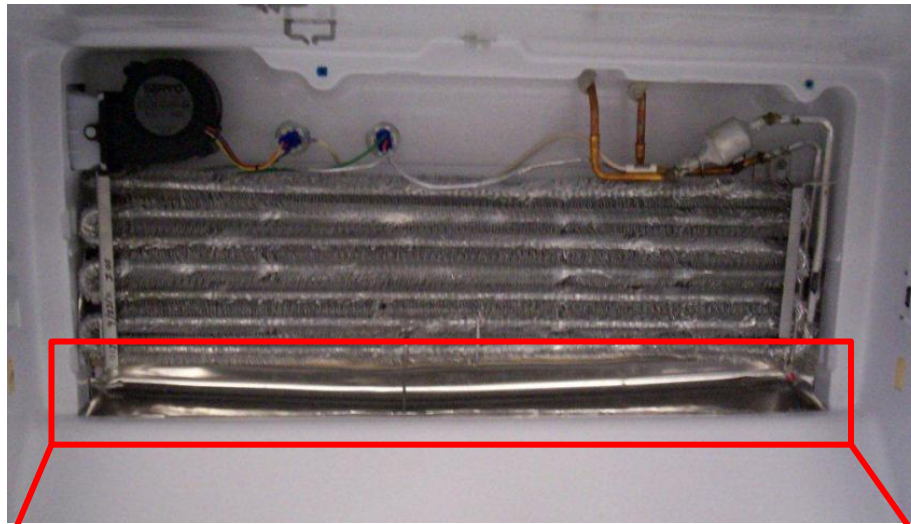

➤ The freezer defrost heater is located at the bottom of the evaporator between the rows of coils, attached to the end plates.

➤ It is a 420 watt glass tube radiant heater.

➤ The heater can be dismantled by removing the right end and center support. Bend the tabs on the end plates inward then pull it down and forward.

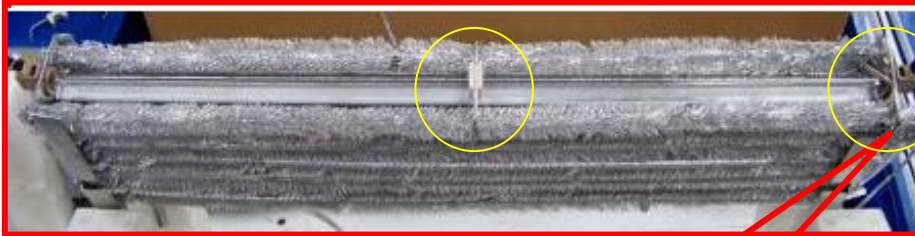

➤ There is a drip shield mounted just above the heater.

➤ There is a 140°F safety thermostat in the neutral line of the heater circuit.

Bend tab inward



*Note: The evaporator is shown inverted for illustration.*

# Machine Compartment

# Machine Compartment location – PFE29

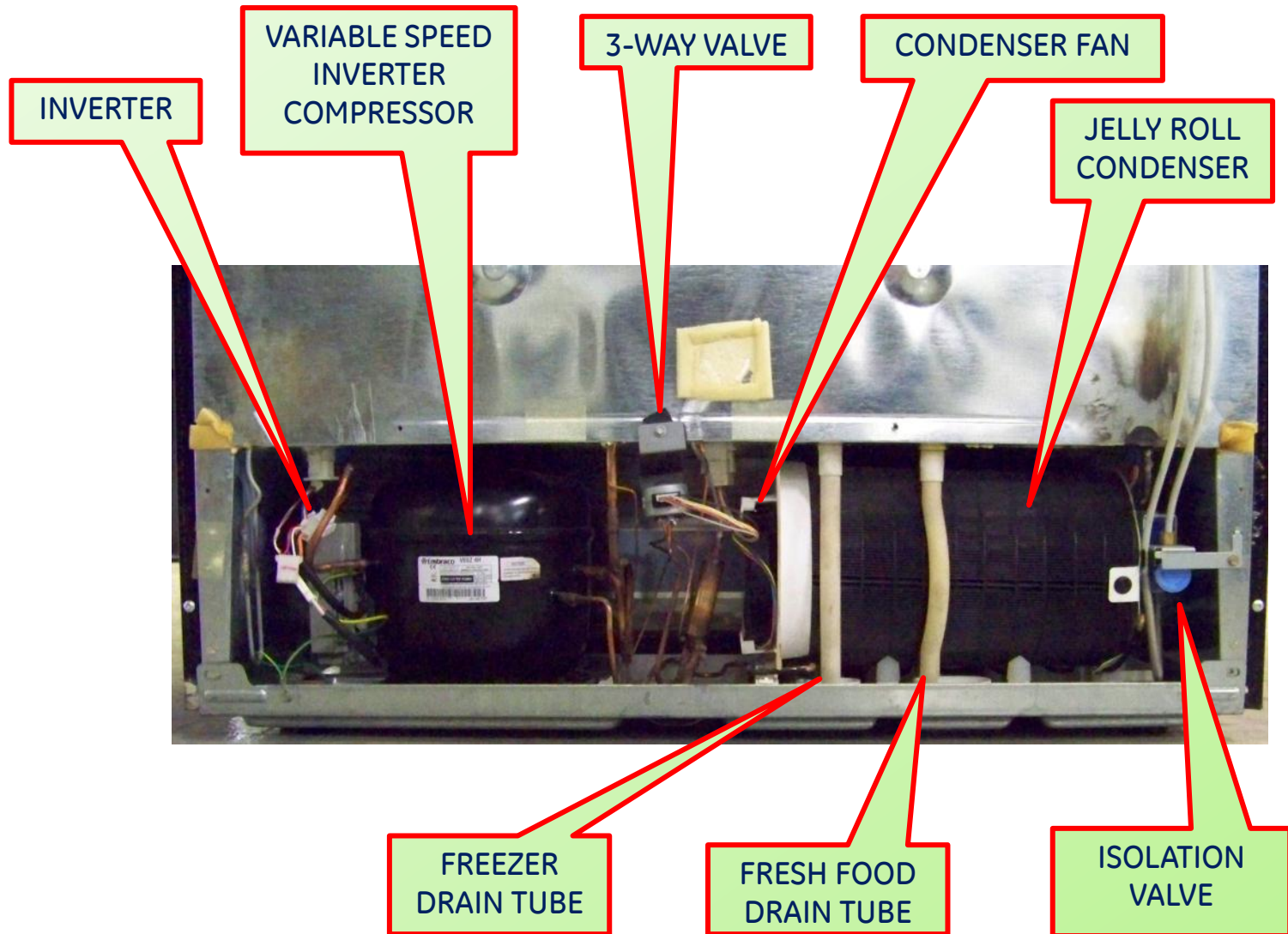

# Machine Compartment location – GFE29

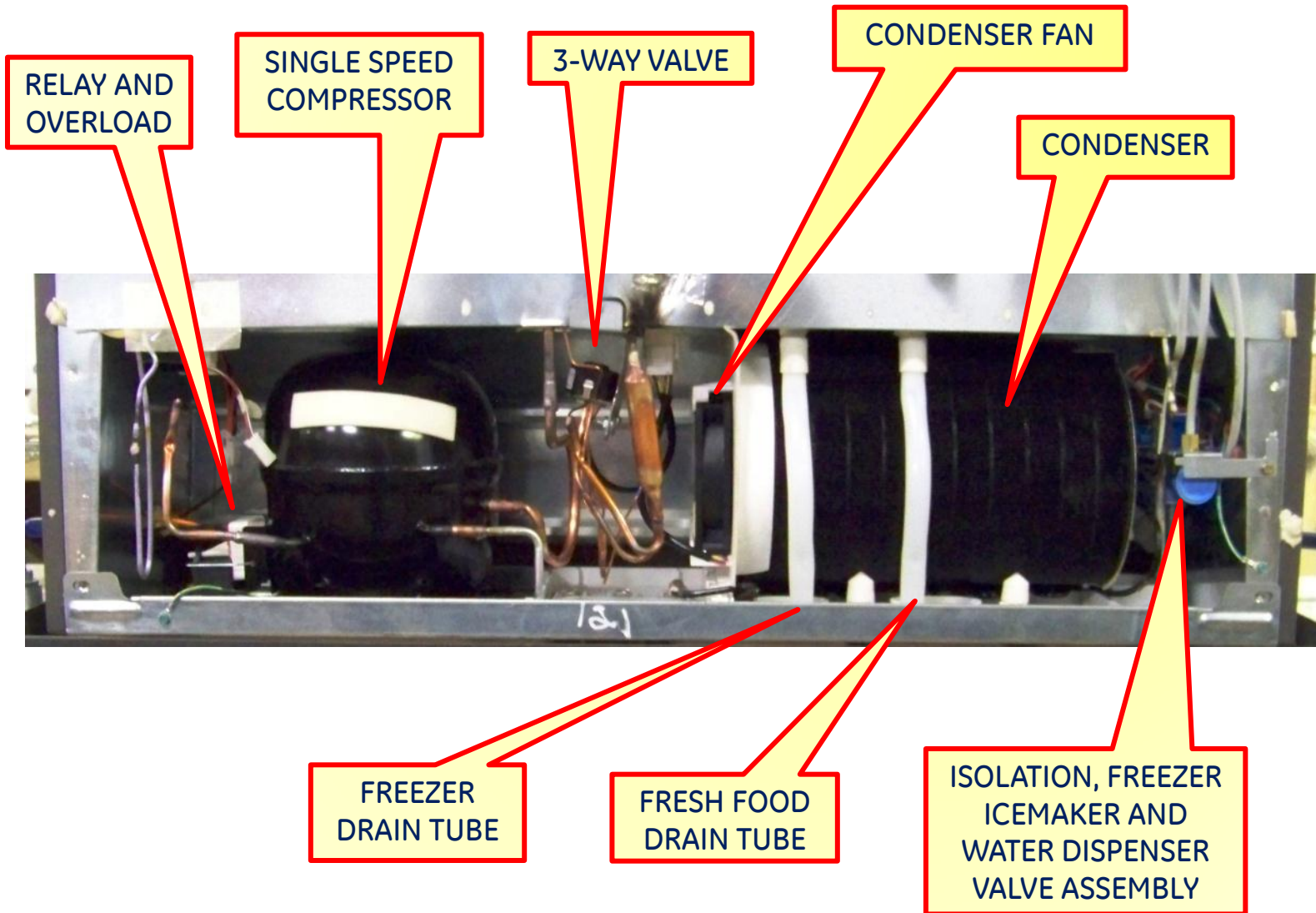

# Isolation Valve

- Water to the filter in the fresh food door is supplied by the isolation valve. The valve prevents the filter from being under constant house water pressure.
- The isolation valve is operated by the main control board.

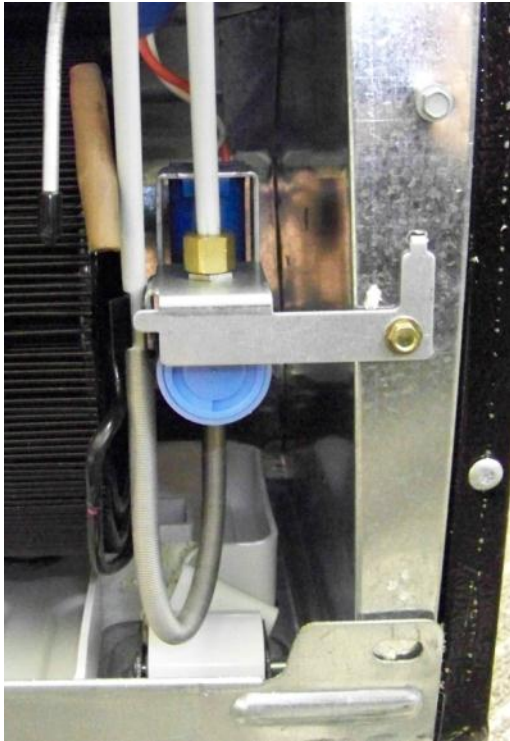

# 3-Way Valve

- The 3-way valve is located in the machine compartment between the compressor and condenser fan.

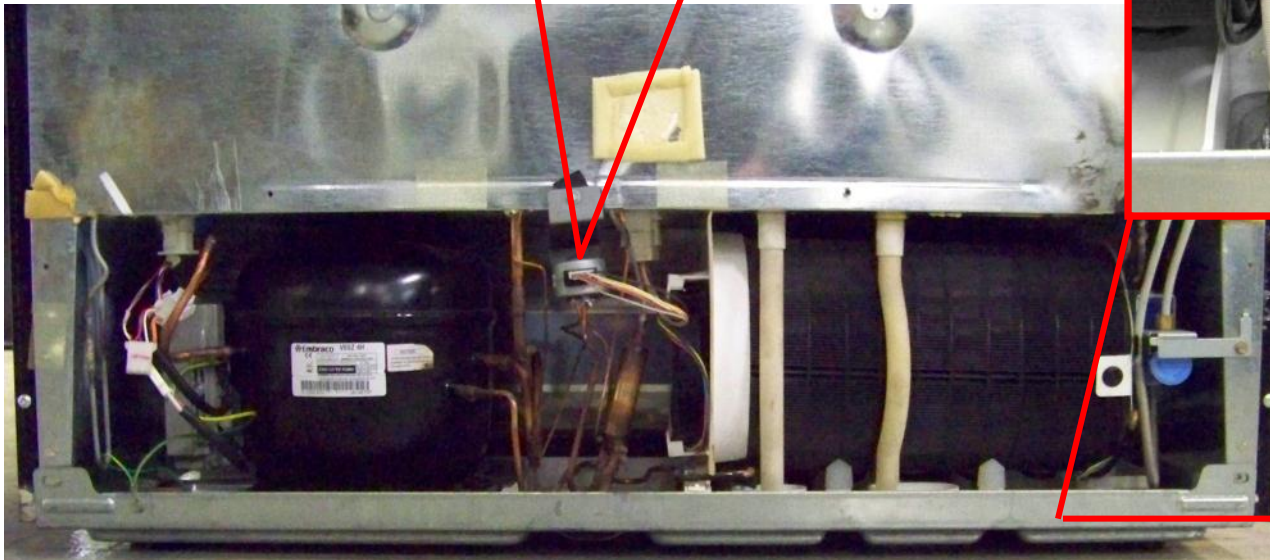

ISOLATION VALVE





# 3-Way Valve

- The 3-way valve is used to direct refrigerant flow.
- The valve has four different positions.

They are referred to by the letters 'A', 'B', 'C' and 'D'

**A** = Open to the Fresh Food and Freezer evaporators in series (refrigerant flows through the fresh food evaporator and then into the freezer evaporator). This is also called the **(Home Position)**

**B** = Open to the Freezer evaporator only

**C** = Open to both the Fresh Food and Freezer evaporators via the individual capillary tubes (this position is not currently used on these models)

**D** = Closed to both Fresh Food and Freezer evaporators during the off cycle

# Freezer Only Cooling

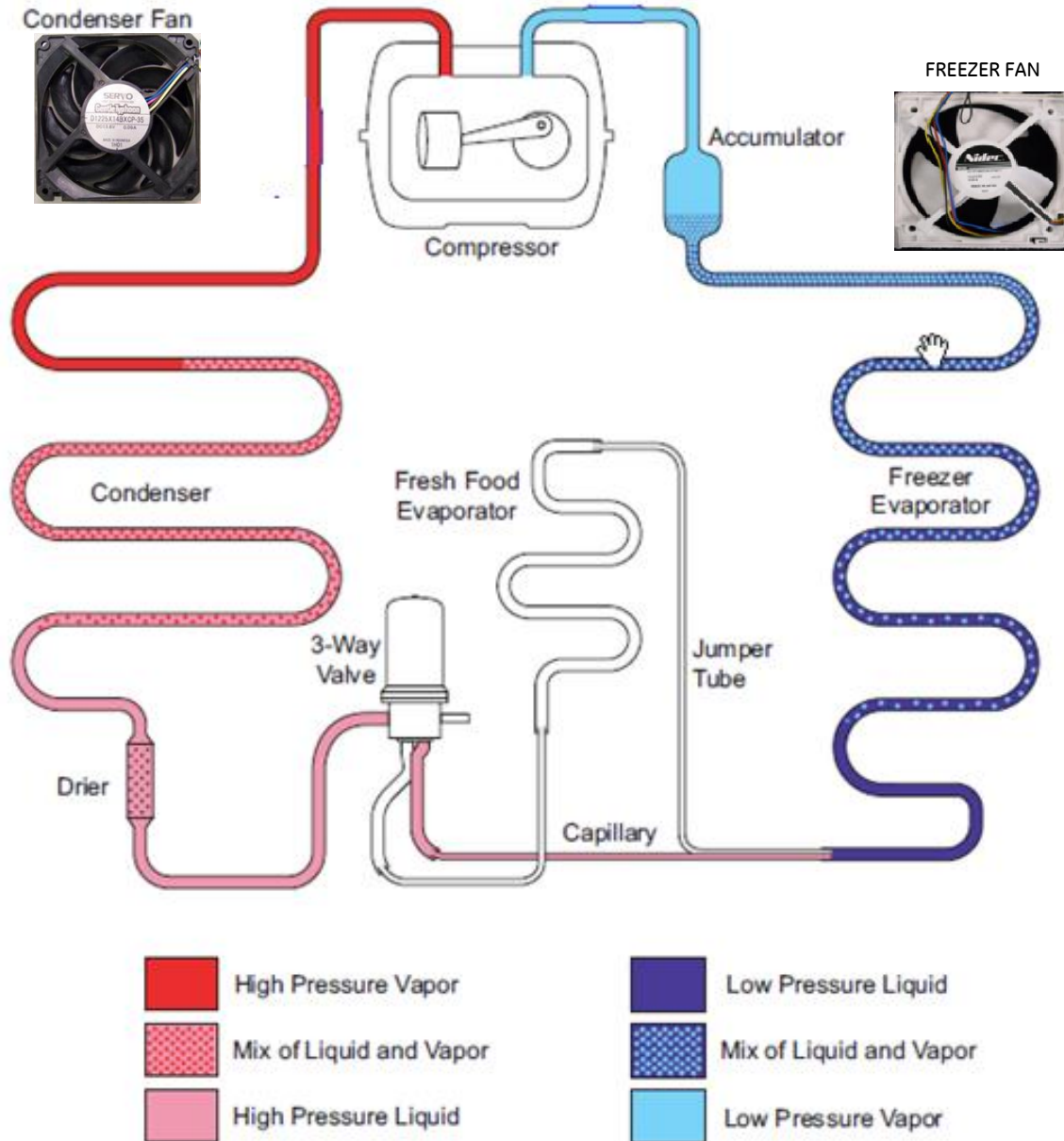

# Fresh Food and Freezer Only Cooling

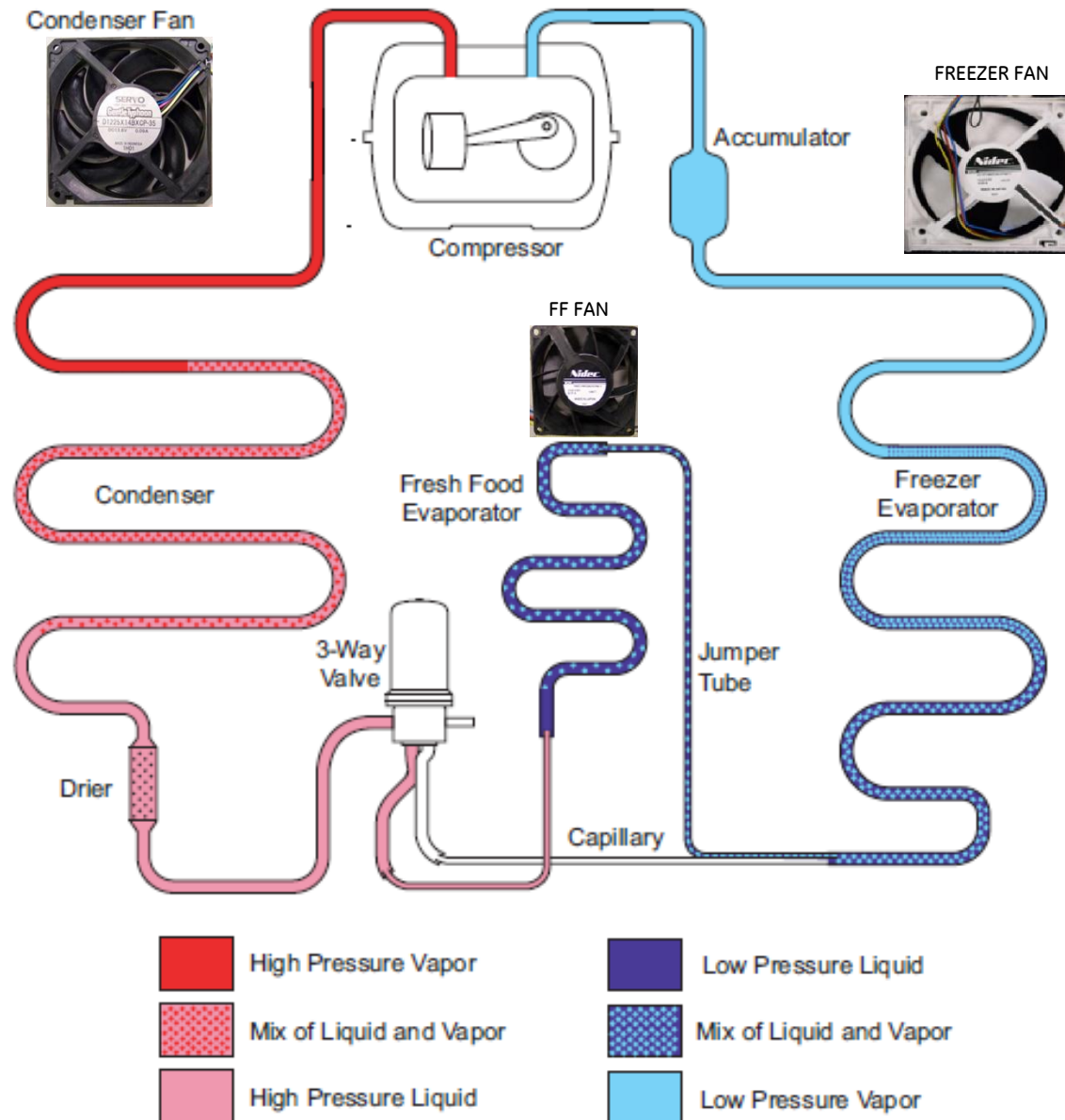

# Condenser Fan Motor

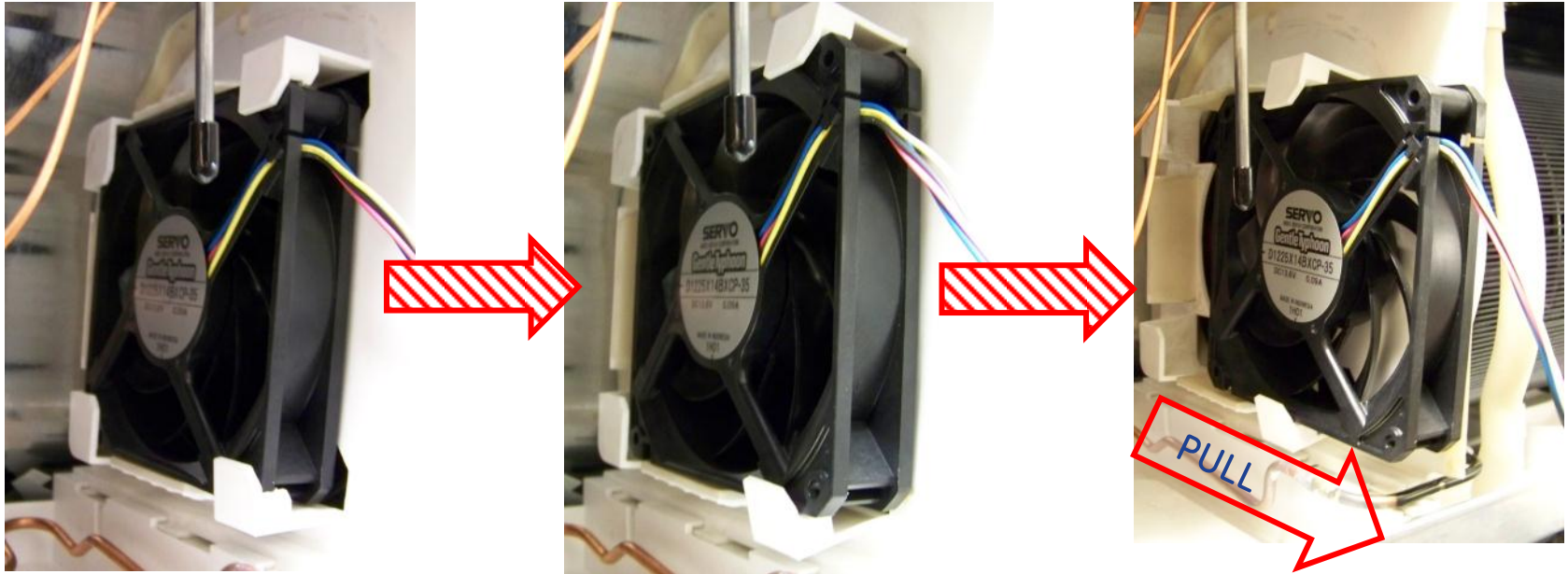

- The condenser fan operates within a range of **1000–2100 RPM\***

To remove:

- Remove the rear access cover
- Disconnect the harness connector
- Pull the fan assembly toward the rear to disengage from the bracket

\* Values are approximate and preliminary



FAN color code:  
**RED** – 12vdc+  
**BLACK** – 12 VDC-  
**YELLOW** – PWM SPEED  
**BLUE** – RPM FEEDBACK

# Operational Overview

# Normal Operating Characteristics

- Liner protection mode will turn on either the fresh food or freezer fan if the doors or drawer are open for more than 3 minutes\* respectively.
- The condenser fan may run without the compressor operating\*
- Dispenser will not operate with either fresh food door open\*
- Fan(s) running without the compressor operating is normal.
- The variable speed compressor uses an inverter like previous variable speed.
- The compressor will start at high speed for 1 minute, then may change to a lower speed based on fresh food and freezer temperature. This may be perceived as a noise issue.
- There is a 20\* second compressor delay on power up, but fans will start immediately if cooling is required.
- Compressor maximum run time is limited to 6\* hours and the minimum compressor off time is 3\* minutes.

# Normal Operating Characteristics

*continued*

- If either fresh food door is open when the freezer drawer is opened, the freezer LEDs on the bottom of the left fresh food door will not come on.
- When either the fresh door(s) or freezer drawer is opened, the fans will turn off.
- The “box type” fans used on these models have different sound characteristics than fans used on previous models. Consumers may perceive this as a noise issue.
- On power-up, if the icemaker rake is not in the home position, the icemaker heater will turn on for 2 minutes before power is applied to the rake motor. Currently, this is only protected by the 210°F TCO on the mold.\* **THE MOLD CAN GET VERY WARM!**
- The duct door is operated by a motor and the consumer may notice a very distinct motor sound when the duct door opens and closes.
- When either fresh food door is opened while dispensing, the dispenser will stop. After the door(s) are closed, the dispenser will not restart until the dispenser paddle switch is released and pressed again.

# Liner Protection Mode

- Liner Protection mode is controlled by two timers.
- Timer #1 monitors door-open time. A 3-minute door-open count begins when the door is opened.
- If 3 minutes elapse before the door is closed, the liner protection mode will become active.
- Once the door is closed, timer #1 resets and liner protection mode goes into standby.
- In standby, normal fan operation resumes and timer #2 begins a 3-minute door-closed count.
- If 3 minutes elapse without a door opening, liner protection mode will reset.
- If a door is opened within the timer #2 door-closed count, the remaining time in the door-closed count will be deducted from the timer #1 door-open count.



# Refrigerator Operation

Both of these models operate in the following states:

- Pull Down
- Cooling Operation
- Fresh food Cycle defrost
- Pre-Chill
- Fresh Food Only Heated Defrost
- Fresh Food & Freezer Heated Defrost
- Dwell
- Post Dwell

# Pull Down

- Pull down occurs any time the refrigerator is plugged in and the freezer temperature is above **60°F\***.
- The 3-way valve moves to the 'B' position. Compressor start is delayed for **20\*** seconds. The compressor will start and run at high speed for 1 minute, then change to low speed (variable speed models only). The freezer fan will run at **HIGH\*** speed.
- When the freezer temperature falls to approximately **12°F\***, the compressor will change to **HIGH\*** speed and the 3-way valve will move to the 'A' position, delivering refrigerant to both the fresh food and freezer evaporators. The fresh food fan will begin running at HIGH speed and the freezer fan will continue to run at **HIGH\*** speed.
- Compressor and fan speeds will vary with cabinet temperatures until the set temperature is obtained.
- After **6\*** hours of compressor run time (*door openings not counted*), both the fresh food and freezer will enter a heated defrost cycle.

\* Values are approximate and preliminary

# Cooling Operation

- When cooling is required, the main control board moves the 3-way valve to either 'A' position (supplying refrigerant to both fresh food and freezer evaporators) or 'B' position (supplying only the freezer evaporator), depending upon compartment temperatures.
- The compressor and fan(s) are delayed for **3\*** minutes before restarting.
- The compressor will start at high speed for 1 minute, then may change speeds depending upon the temperature of both the fresh food and freezer.
- When only the fresh food temperature is satisfied, the 3-way valve will move to the 'B' position (supplying only the freezer evaporator) to continue cooling the freezer. Fresh food cycle defrost will begin.
- When the freezer and fresh food temperatures are satisfied, the compressor and fans will turn off. The 3-way valve will move to the 'D' position, shutting off refrigerant flow to both evaporators to reduce refrigerant sounds.
- After the accumulated compressor run time (including door openings) has been reached, the unit will begin the defrost pre-chill cycle.  
( **1 second of door opening = 100 seconds of compressor run time\***)

\* Values are approximate and preliminary

# Fresh Food Cycle Defrost

- Fresh food cycle defrost occurs between heated fresh food defrost cycles to reduce excessive frost accumulations on the fresh food evaporator.
- During fresh food cycle defrost, the evaporator fan runs and there is no refrigerant flow through the evaporator.
- Fresh food cycle defrost does not use the fresh food defrost heater.
- Fresh food cycle defrost will occur any time the 3-way valve is moved from the 'A' position to the 'B' position. The fresh food fan will run at **LOW\*** speed for **10\*** minutes, then cycle off if fresh food temperatures are satisfied.
- The fresh food cycle defrost does not occur when the compressor cycles off.

\* Values are approximate and preliminary

# Defrost Pre-Chill

*(Single and Variable speed compressor)*

- After accumulating 96\* hours of compressor run time (actual compressor run time and door openings), the operating system will enter pre-chill.
- Pre-chill will occur whether the last freezer defrost was normal or abnormal.
- Pre-chill time will vary from 10 to 60\* minutes, depending on door openings and compartment temperatures during pre-chill.
- Any compressor run time prior to the beginning of pre-chill does not count in the pre-chill time.
- There is a 6\* second delay after the compressor cuts off at the end of pre-chill before energizing the defrost heaters.
- The ice box fan will run at high speed whenever ice box cooling is needed during the pre-chill cycle.
- Pre-chill ends when either the maximum time expires (60 minutes\*), evaporator pre-chill temperatures are met (-30F\*) or freezer pre-chill temperatures are met (-10F\*).

\* Values are approximate and preliminary

# Fresh Food Only Heated Defrost

- Fresh food only heated defrost occurs after 32\* hours of compressor run time.
- Fresh food only heated defrost does not use a pre-chill cycle.
- Door openings are factored into the compressor run time.  
1 second door opening = 100 seconds of compressor run time\*
- Providing previous freezer or fresh food only heated defrost cycles were normal the freezer will defrost every 3<sup>rd</sup>\* fresh food defrost.

\* Values are approximate and preliminary

# Freezer and Fresh Food Heated Defrost

- Following pre-chill, the heated freezer and heated fresh food defrost cycle is initiated where both heaters will be on at the same time.
- The 3-way valve will move to the 'A' position. The compressor will turn off. The condenser, freezer, fresh food, and ice box fans will turn off.
- The freezer defrost heater remains on until the freezer evaporator is  $50^{\circ}\text{F}^*$  (defrost termination temperature) or the maximum defrost time of  $45^*$  minutes is reached.
- The fresh food defrost heater remains on until the fresh food evaporator is  $45^{\circ}\text{F}^*$  (defrost termination temperature) or the max defrost time of  $45^*$  minutes is reached.
- If either the fresh food or freezer defrost heater's on time exceeds the normal defrost threshold of approximately  $20$  minutes\*, the defrost is considered abnormal. (Abnormal defrost forces both the fresh food and freezer into pre-chill after  $6^*$  hours of compressor run time -*door openings not counted*).
- During defrost, if power is interrupted, the refrigerator will restart in the dwell state if the freezer evaporator temperature is above  $50^{\circ}\text{F}^*$  (defrost termination temperature).
- After the defrost heaters turn off, the refrigerator will enter the dwell cycle.

# Dwell Cycle

- After both defrost heaters have cycled off, the unit will enter the dwell cycle.
- During the dwell cycle, the compressor and fans will remain off. The 3-way valve will move to the 'A' position (both fresh food and freezer open) and remain there for the entire cycle.
- Dwell cycle will terminate after 10\* minutes.
- At the end of the dwell cycle, the compressor run timer for adaptive defrost is reset to 0 hours and the refrigerator enters the post-dwell cycle.
- If power is interrupted during the dwell cycle and the freezer temperature is greater than 50°F\* (the freezer defrost termination temperature), the dwell cycle will start over. *Note: Pull down will start if the freezer temperature is over 60°F*



# Post Dwell Cycle

- Upon completion of the dwell cycle, the unit will enter the post dwell cycle.
- The 3-way valve will move to either the 'A' or 'B' position, depending upon whether the fresh food temperature is satisfied.
- The compressor and condenser fan will start, but the fresh food fan, freezer fan and ice box fan will remain off.
- Post dwell will end when the freezer and fresh food evaporators reach the post dwell exit temperature of  $-10^{\circ}\text{F}^*$ , or the post dwell time of  $10^*$  minutes has expired.
- Upon exit of post dwell, the control system will now operate all cooling components by it's logic and restarts the compressor run timer for adaptive defrost.

\* Values are approximate and preliminary

# Refrigerator Operation Summary

Both of these models operate in the following states:

- **Pull Down** occurs when the refrigerator is powered up and freezer is above 60°F
- **Cooling Operation** is the normal cycling of temperatures whether the last defrost was normal or abnormal.
- **Fresh Food Cycle Defrost** occurs when the 3-way valve turns off refrigerant flow to fresh food evaporator, but the freezer continues to cool.
- **Pre-Chill** occurs before freezer heated defrost.
- **Fresh Food Heated Defrost** occurs every 32 hours of compressor run time.
- **Freezer Heated Defrost** occurs every 96 hours of compressor run time.
- **Dwell** occurs after every heated defrost cycle.
- **Post Dwell** occurs after every dwell cycle.

# User Interface (UI) Controls

# Consumer Control Board (PFE29)

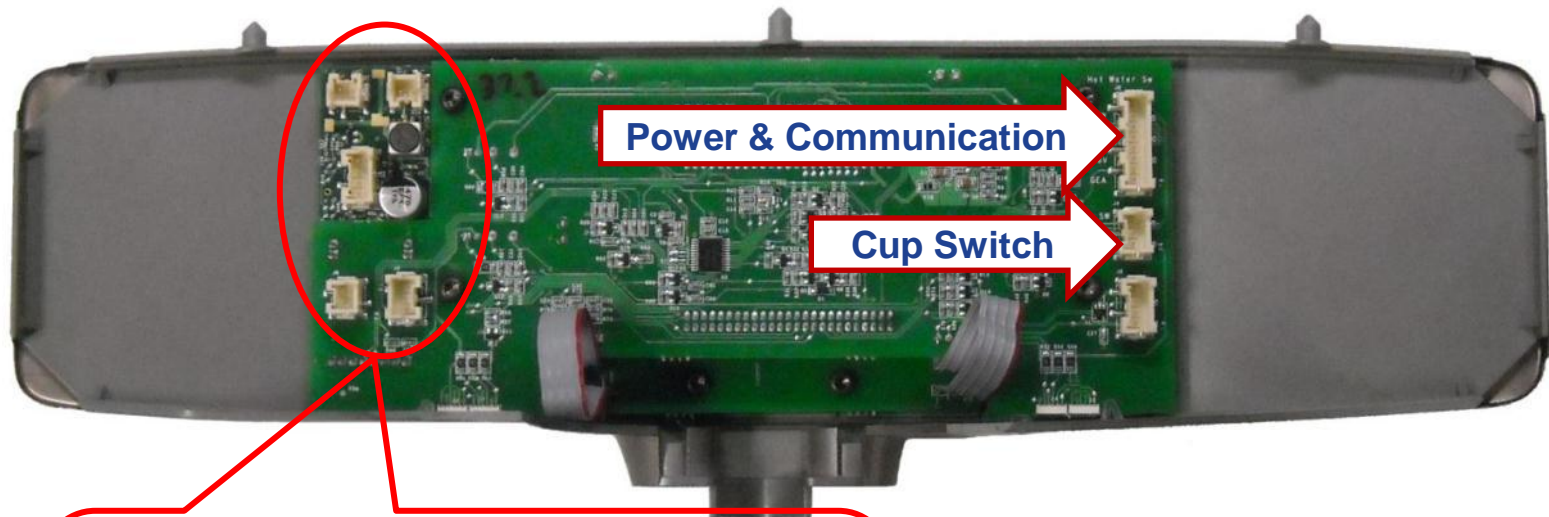

Power & Communication

Cup Switch

- ULTRASONIC SENSOR CONNECTORS FOR SENSOR FILL
- SOUND MODULE CONNECTOR

# Consumer Control LCD Models (PFE29)



# Consumer Control Board (PFE29)

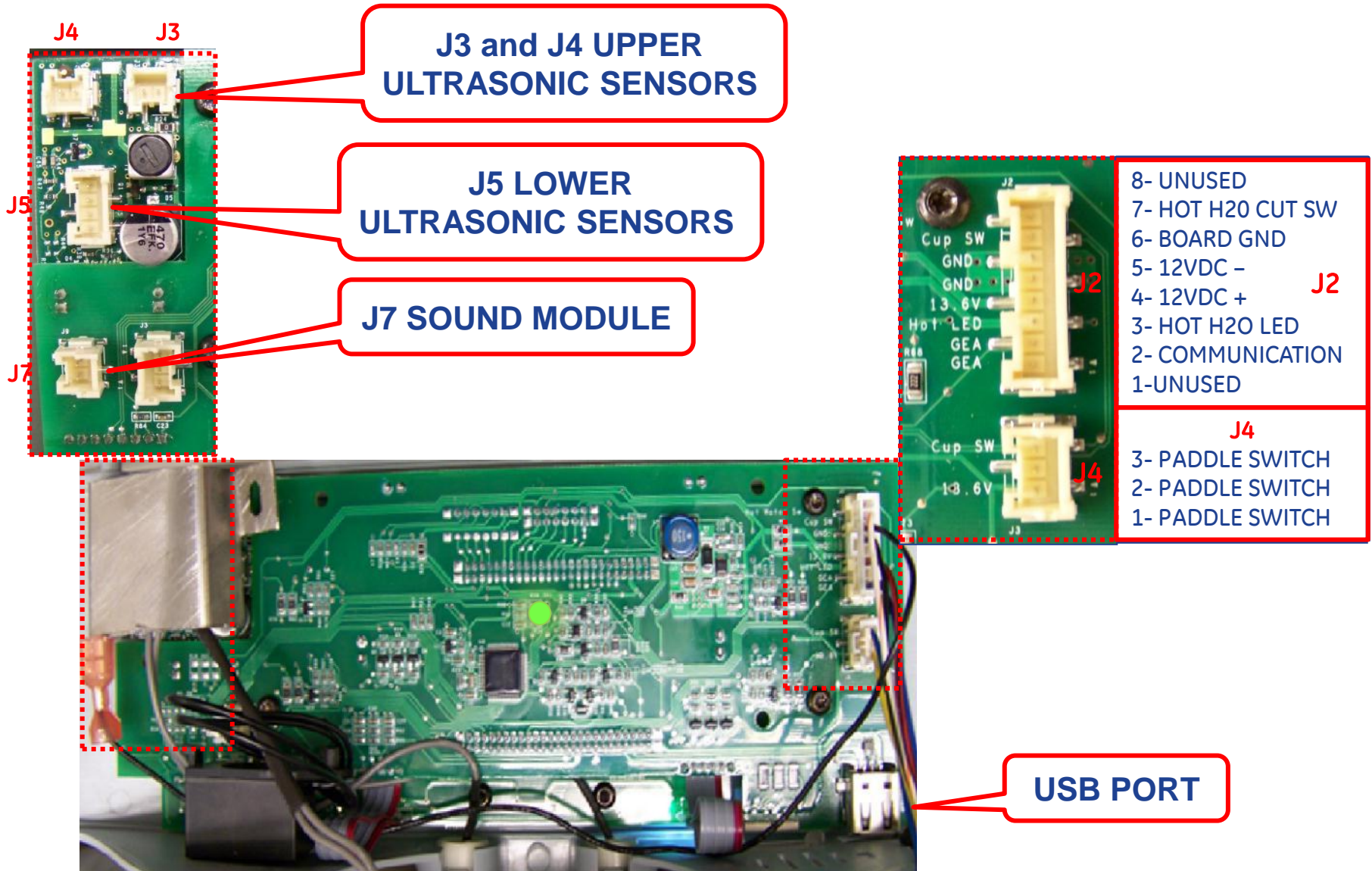

A blinking green LED means the board's DC power supply is on and operating.

# Consumer Control Temperature Adjustment

Note the LCD customer control does not incorporate pads for temperature adjustment. To change compartment temperatures; touch the screen to wake the control up and change temperatures directly on the LCD screen.



# Consumer Control Temperature Controls

Once 'Temp Control' is pressed, the adjustment screen will appear in the display. After adjusting to the desired temperature setting, press 'Done'.



The customer also has the option to change the displayed temperature from '°F' to '°C' from this screen.





# Consumer Control Dispenser Functions

When the customer changes the dispenser functions, the display will show a short animation of the dispenser selection.



# Consumer Control Express Modes

The 'Express Modes' option allows the consumer to turn on or off the 'Turbo Cool' and 'Turbo Freeze' functions.



# Consumer Control Precise Fill Options

There are two modes of operation for water dispense. Standard 'Precise Fill' where the customer selects the amount of water and 'Sensor Fill' where the dispenser uses sensors to automatically fill the container to 90% full.



In 'sensing fill', if no container is in the dispenser, the unit will not operate and notify the consumer.



# Hands Free AutoFill

Industry First

- Hands free auto fill uses 3 ultrasonic sensors to measure the height, width, volume and shape of the container and will fill it to approximately 90% of its capacity.
- Ultrasonic sensors work in much the same way as back-up sensors used on many automobiles.
- This system is operated by the LCD control and the door control board.
- If there is a failure, the ultrasonic sensors and LCD control are replaced as an assembly.



# Consumer Control System Settings

When the consumer selects 'Settings' from the main screen, they can change or reset functions on the unit by scrolling through the screens.

- Reset the water filter
- Turn the icemaker on and off
- Turn the door alarm on and off
- Turn the control sound on and off
- Turn the cooling system on and off
- Change the temperature display to 'F' or 'C'
- Change the water dispenser from US Imperial to Metric

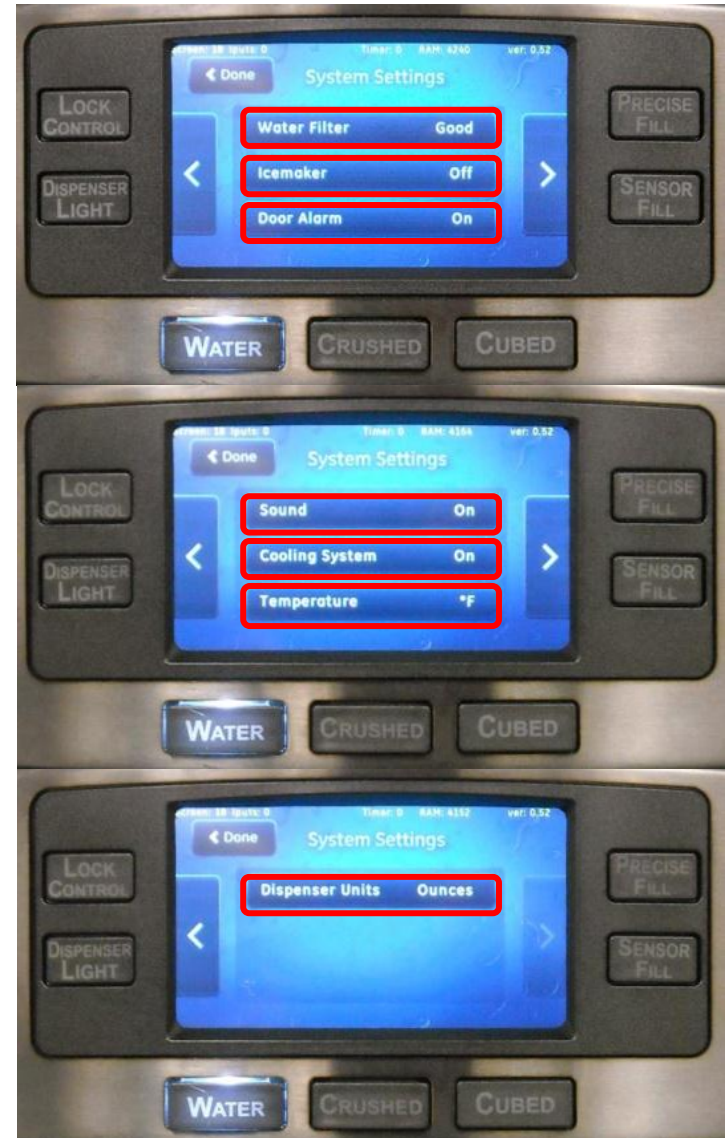

# Dealer Demo Mode

- Enter demo mode by pressing the 'Lock' and 'Precise Fill buttons'
- Exit demo mode by pressing the same buttons again or cycling refrigerator power.



Entering Demo Mode



Enter Demo Mode?

Yes

No

# Dealer Demo Mode

*When Dealer Demo mode is active the following will occur:*

- The compressor is off at all times.
- All heaters will be disabled.
- The icemaker(s) are turned off, but control will operate the display function.
- The fans and dampers may run if prompted by a user setting change.
- Opening the doors will not turn on the fans.
- Liner protection mode is active.
- The deli pan LED lighting will work normally.
- The deli fan will turn on at the heating mode speed.

- The deli pan settings will remain the same between door openings, as the set points are not reset.
- LED lighting will come on when the door or drawer is opened and stay at full power for 8 minutes if the door remains open.
- After 8 minutes, the LEDs will start to lower their intensity in a smooth transition over the next three minutes to 75% of their original power and remain there until the door(s) is closed. Closing and reopening the doors will restart the timer.
- The user can activate and deactivate the Door Alarm, Lock, Dispenser Light, and Reset Filter functions.
- The user can adjust the temperatures, but the cooling components will not operate.



- The user interface will display the actual compartment temperatures.
- Paddle and switch will not operate dispenser components if pressed.
- The Precise Fill feature can be selected and amount of water set, but water valve will not be activated.
- The Auto Fill can be set but will not activate water valve. An instructional video will play for 49 seconds and then return to the home screen.
- Turbo Cool and Turbo Freeze can be turned on and off, but no cooling action will be initiated.

# RJ45, Ambient Thermistor and Humidity Board

The 'Zigbee™' Board is located on the top of the case in the hinge cover and monitors the ambient air temperature and humidity level of the room. This board also contains the RJ45 connector for the Brillion Technology ACM and computer diagnostics.

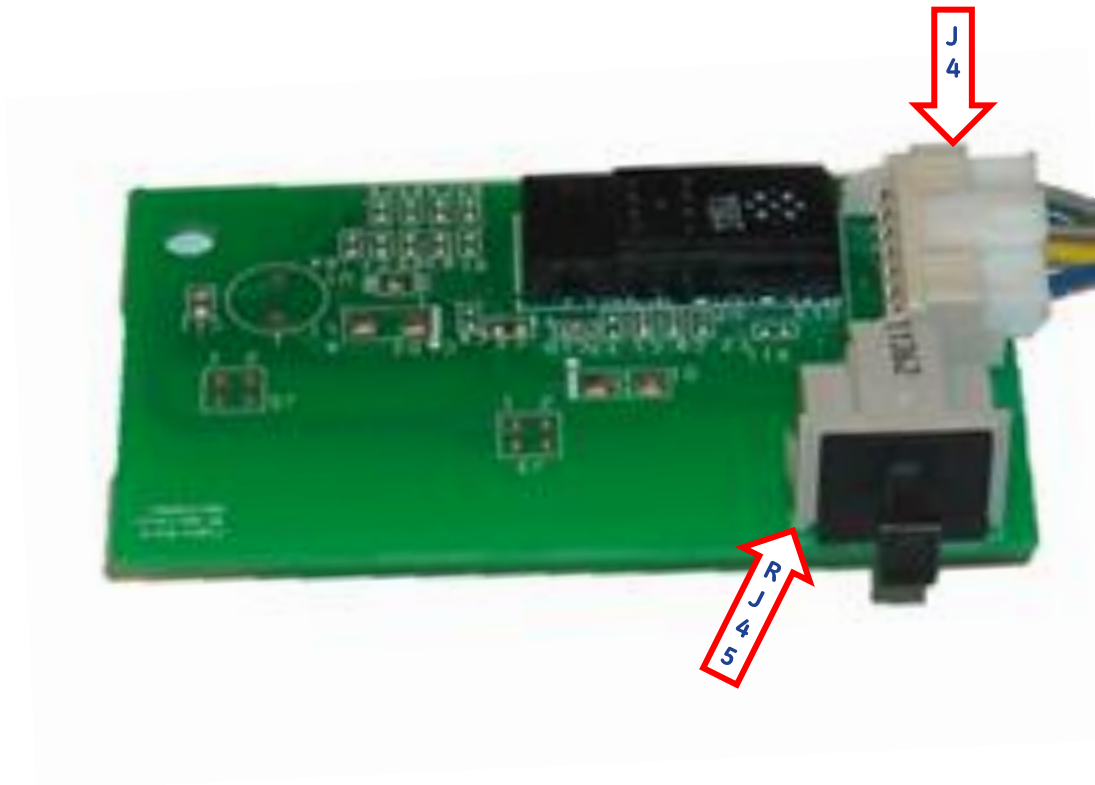

# NewFI

The 'Zigbee™' Board RJ45 connector allows the Factory Service technician to connect to the refrigerator to perform diagnostics on their laptop computer. The technician will be able to access error codes, current functions, operational history and operate loads for diagnosis. Remove the plastic plug to access.

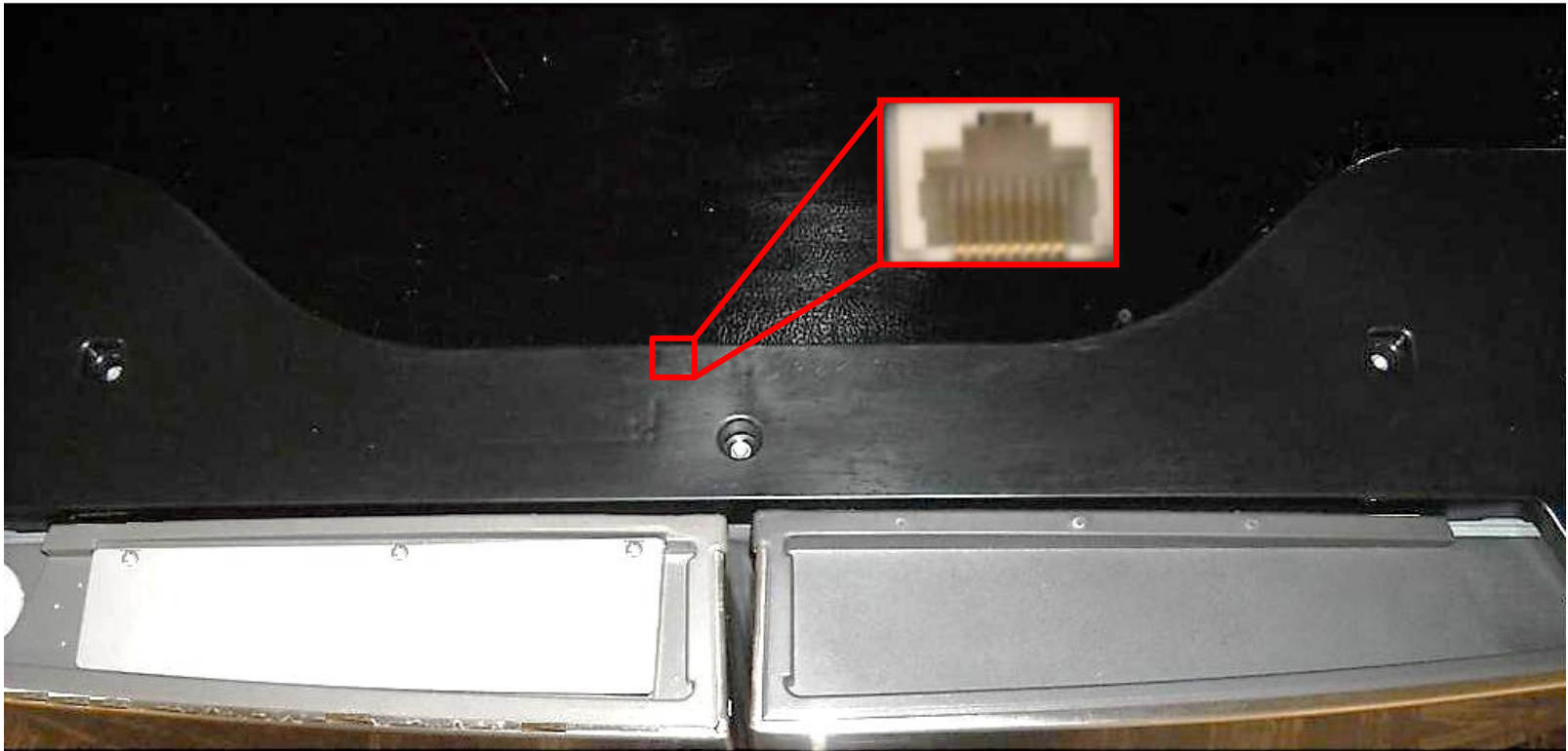

# Sabbath Mode

To enter or exit Sabbath mode; press the 'Lock Control' and 'Dispenser Light' buttons for three seconds.



# Sabbath Mode

- This feature was designed for use on the Jewish Sabbath Holiday.
- The Sabbath Mode feature will override typical interaction with the refrigerator.
- In Sabbath Mode the refrigerator will still cool normally, but will not respond to user's actions.
- The LCD display will change to a screen prompting the consumer to enter or exit Sabbath mode.
- The display will show "Entering Sabbath Mode" or "Exiting Sabbath Mode" for 3 seconds and then disappears.
- The display will show "Sabbath Mode" while the control is in Sabbath mode.
- All of the displayed icons will be turned off.
- All of the sounds and tones will be turned off.
- The Sabbath mode will expire 76 hours after being activated by the consumer.

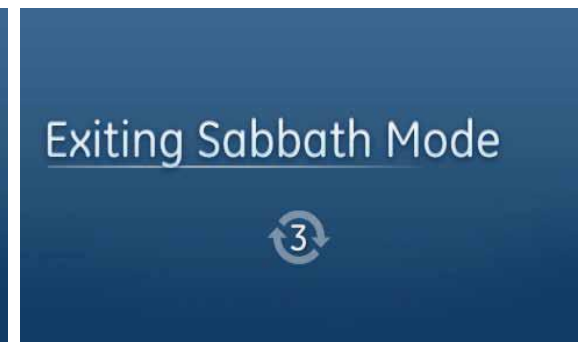
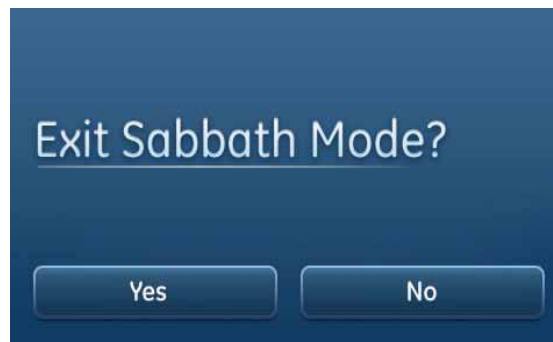
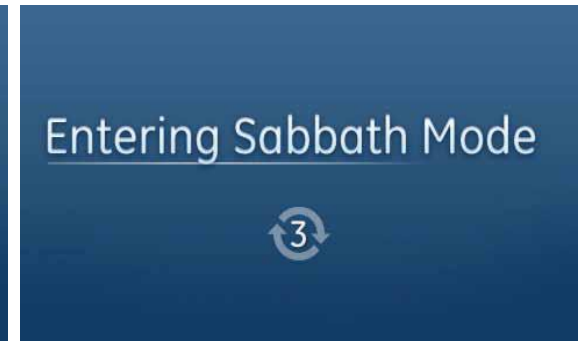
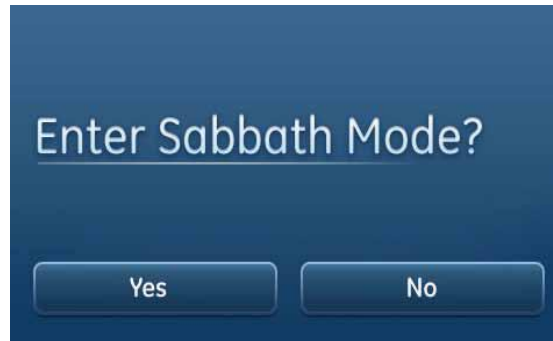

- The fan may or may not be running when the door is opened; however, this is not a result of the user's actions.
- There is a delay on all control changes (fans and compressor) while the door is open. This includes any fan action as a result of doors opening.
- After a power outage, the refrigerator will power back up in the Sabbath Mode.
- The temperature settings of the refrigerator will remain as set prior to turning on Sabbath Mode and will return to those setting after Sabbath Mode is turned off.
- The door alarm is disabled.
- All of the button actions on the dispenser will be ignored by the control during Sabbath mode.
- The dispenser auto fill ultrasonic sensors for 'Sensor fill' are disabled.
- The water valve, auger motor and duct door motor are disabled.
- The icemakers are inoperative during Sabbath Mode.
- Door openings are not counted for adaptive defrost, so the user has no influence on the defrost process.
- The time between defrost cycles is fixed at 8 hours. The defrost heater termination is controlled by temperature.

# Sabbath Mode

**GFE29 UI**



**FUTURE MODELS**



# GFE29 LED User Interface

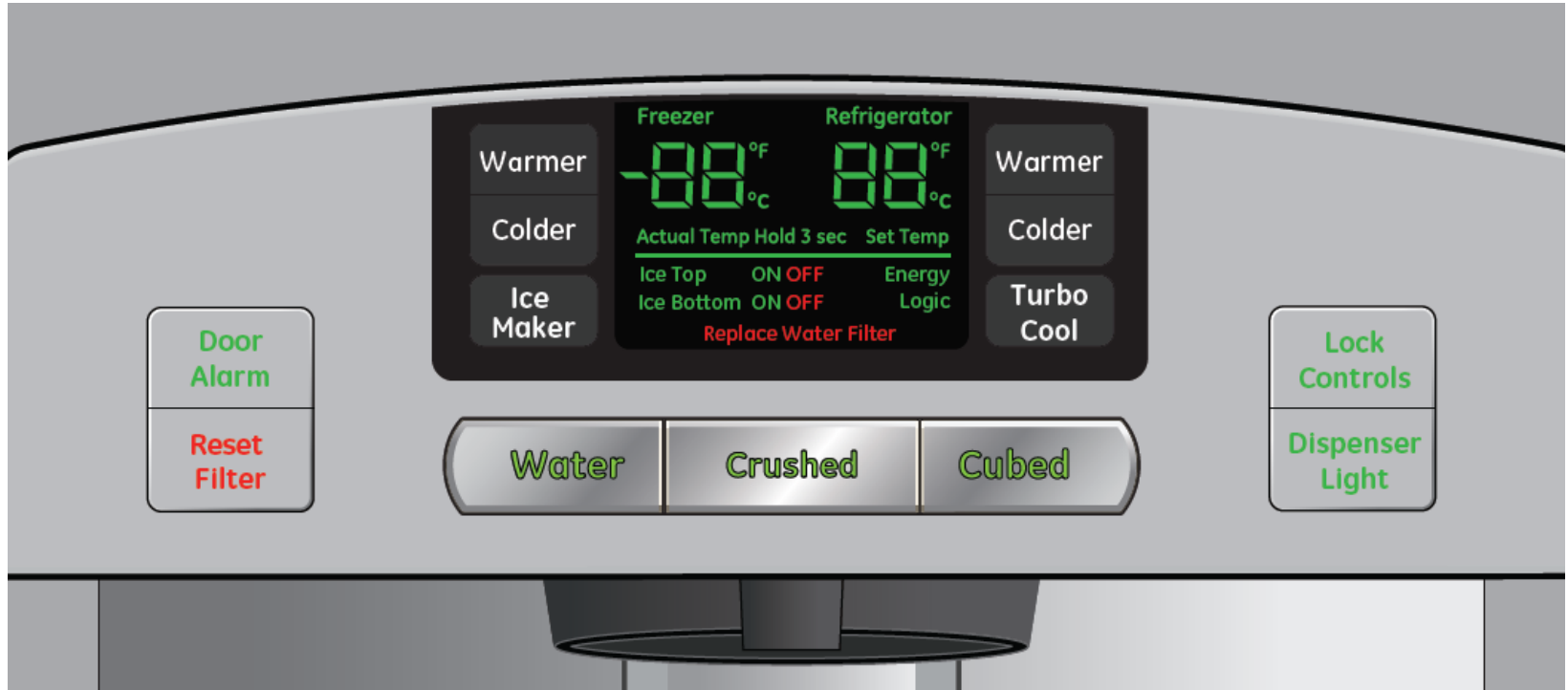

*Note: DC ground is extremely important on all control boards. On this model you could see '0's moving in a racetrack pattern.*



# GFE29 LED User Interface

- The **Warmer/Colder** buttons adjust the fresh food and freezer temperatures.
- The 7-segment display shows the “Actual Temp” or “Set Temp” of the fresh food and freezer temperatures.
- The **Ice Maker** button is toggled to turn on or off the fresh food door and freezer icemakers. “Ice Top” is the indicator for the fresh food door icemaker and “Ice Bottom” is the indicator for the freezer icemaker.
- The **Turbo Cool** button is toggled to activate the fresh food “turbo cool” and/or the freezer “turbo freeze” features. The fresh food 7-segment displays “tc” when in “turbo cool” and the freezer 7-segment displays “tf” in “turbo freeze” mode.
- If the water filter timer has expired, the “Replace Water Filter” display will be on.
- The **Reset Filter** button will reset the water filter timer.
- The **Door Alarm** button will activate and deactivate the door alarm.
- The **Lock Control** will prevent the consumer from interfacing with the refrigerator.
- The **Dispenser Light** button will turn on or off the dispenser light.
- The **Water/Crushed/Cubed** functions are exclusively linked by the system logic. Pressing one button selects the function and turns off the other two functions. The appropriate LED is lit when a function is selected. When the door switches are closed and the cup switch is depressed, dispensing occurs according to the selected function.

# Control Block Diagram

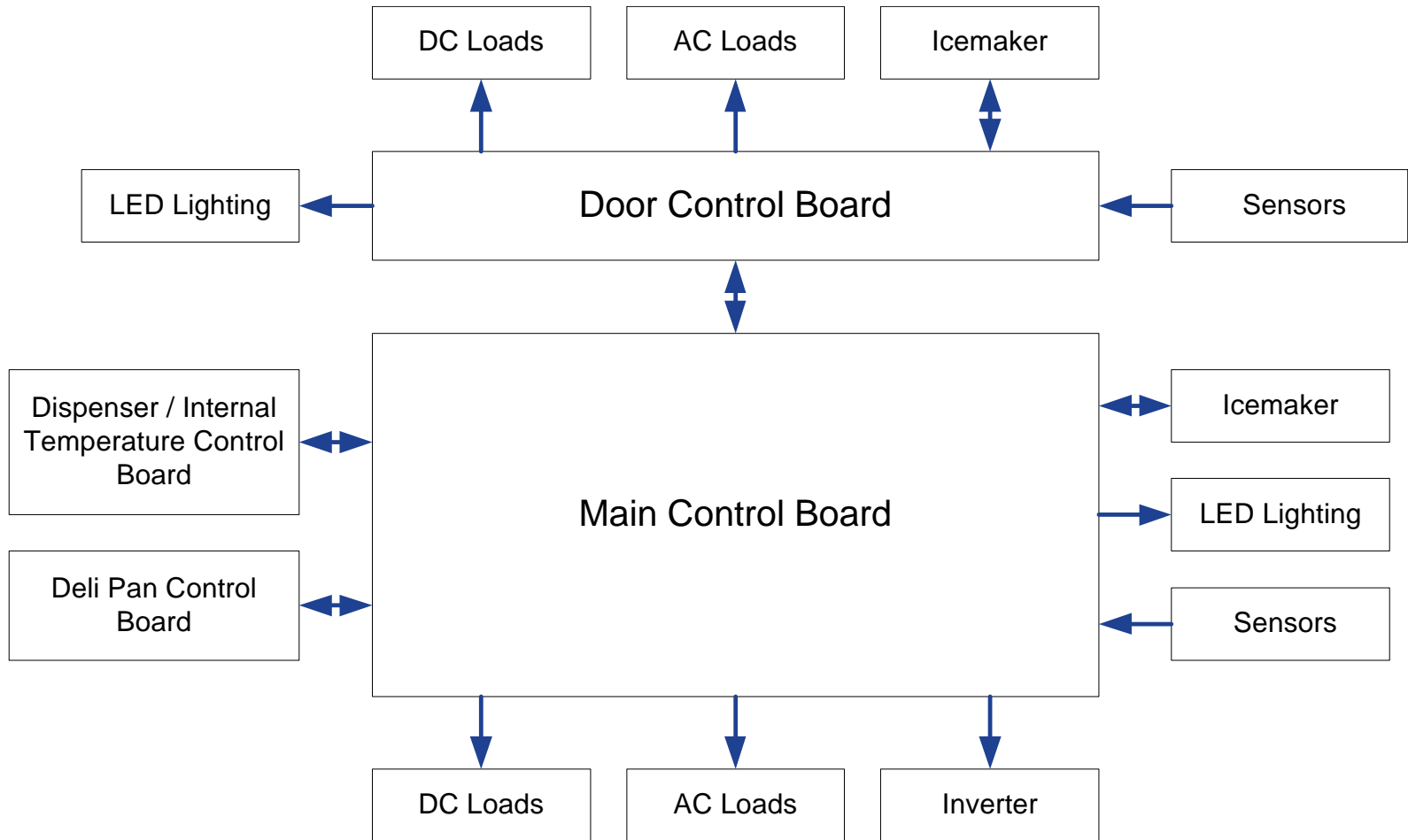

# Main Control Board

# Main Control Board

The main control board operates some or all of the following outputs depending on the model identification used:

- Freezer temperature control using compressor, fans and 3-way valve
- Fresh Food temperature control using compressor, fans, 3-way valve and damper (*single evaporator models*)
- Ice Box temperature control
- Deli pan control using the damper, fan and heater
- Variable fan speed control with RPM feedback for the condenser, fresh food and freezer evaporator, ice box and deli pan fans
- Freezer and fresh food evaporator defrost control
- Icemaker control for models with an icemaker in the freezer
- Control of the isolation water valve
- Control of mullion and ice port heaters based on external temperature and relative humidity
- Control of the fill tube heater for the icemaker located in the freezer
- Control of the interior LED lighting in the fresh food compartment

# Main Board Location

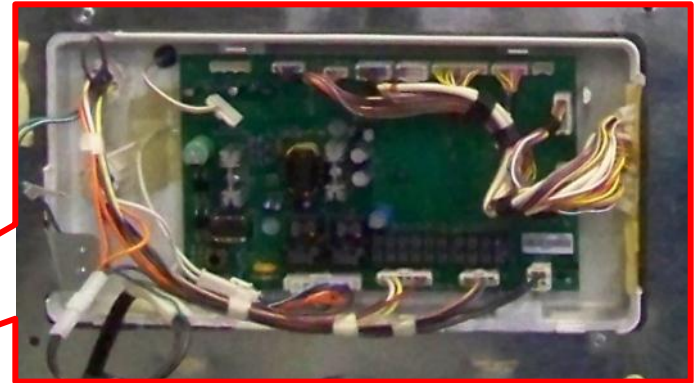
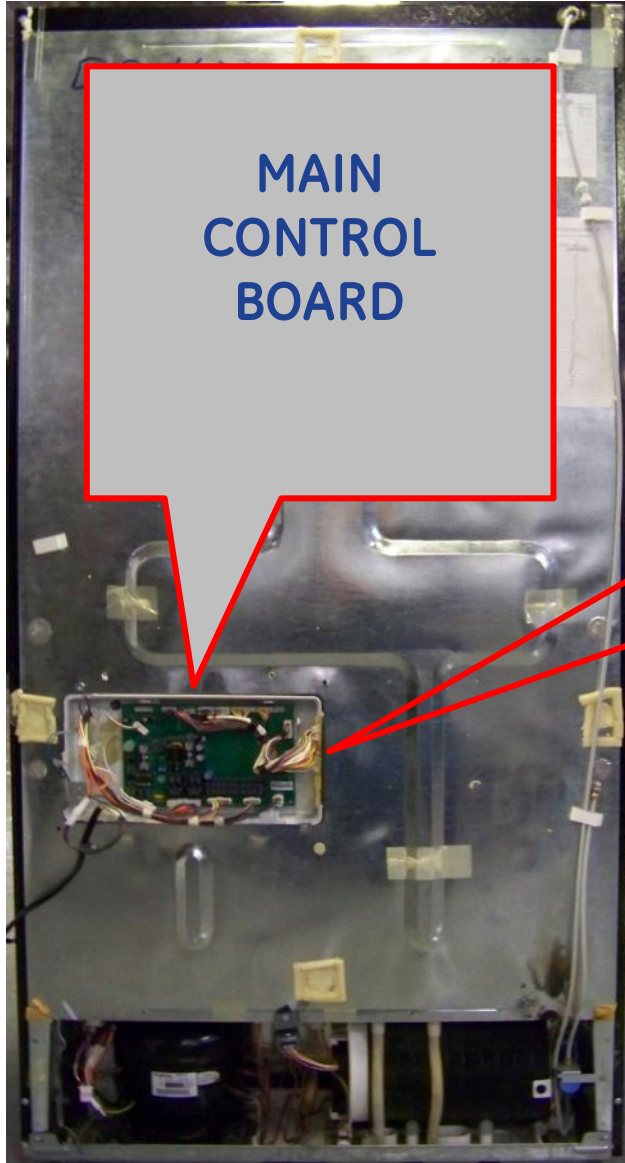

# Main Control Board Block Diagram

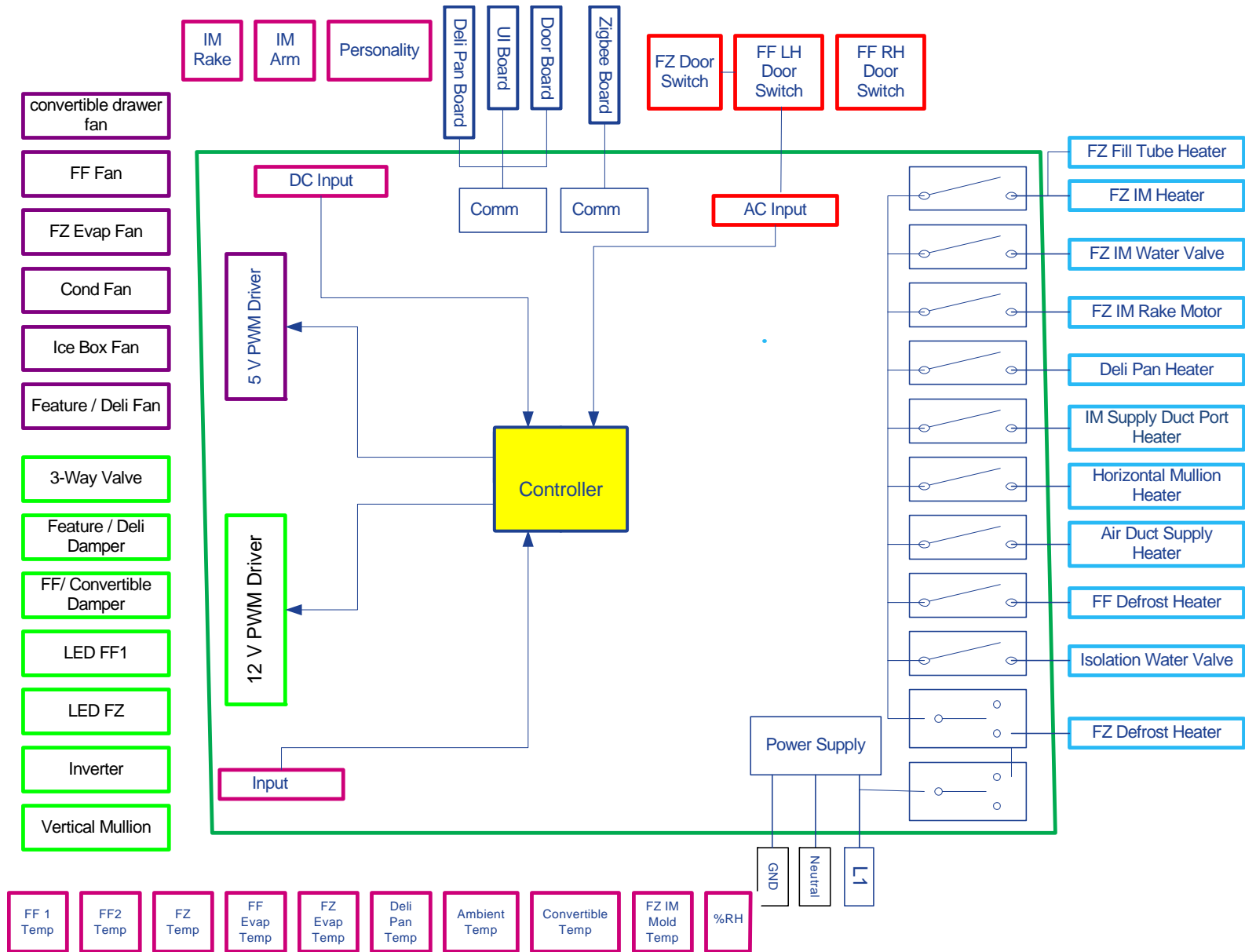

# Main Control Board

A blinking green LED means the board's DC power supply is on and operating.

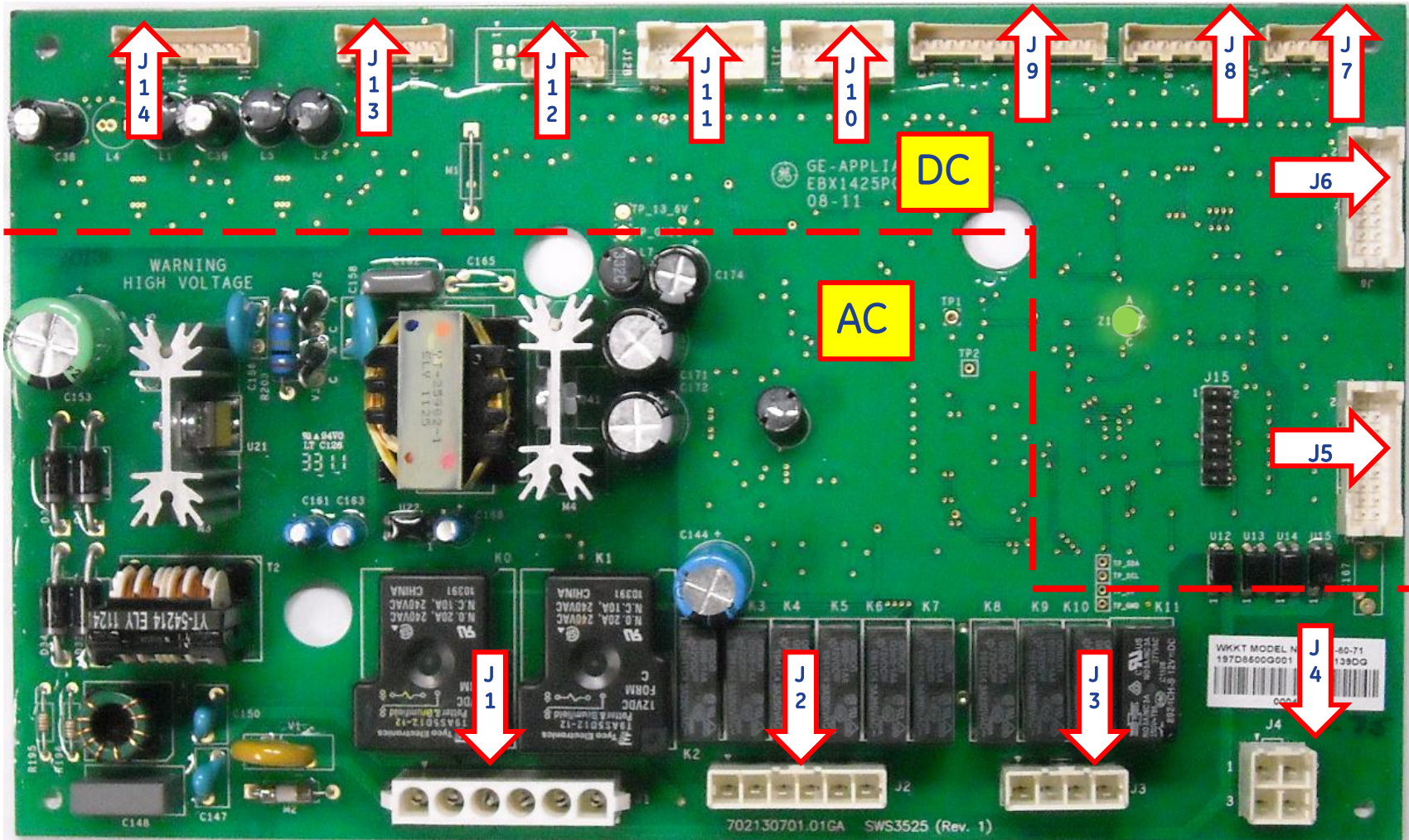

# Main Control Board DC

- PIN 1 - ZIGBEE BUS
- PIN 2 - UI & DOOR BUS
- PIN 3 - ZIGBEE & UI BRD GND -
- PIN 4 - DOOR BRD GND -
- PIN 5 - 12 VDC ZIGBEE BRD +
- PIN 6 - 12 VDC UI BRD +
- PIN 7 - 12 VDC DOOR BRD +

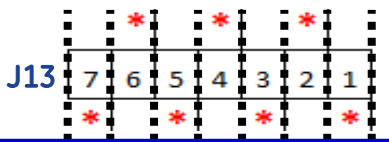

- PIN 1 - 12VDC DELI +
- PIN 2 - DELI BUS
- PIN 3 - DELI BRD GND
- PIN 4 - OPEN
- PIN 5 - OPEN
- PIN 6 - OPEN
- PIN 7 - DELI THERMISTOR 5VDC
- PIN 8 - DELI THERMISTOR



- PIN 9 - FF EVAP THERMISTOR 5VDC
- PIN 10 - FF EVAP THERMISTOR
- PIN 11 - 5VDC THERMISTOR OPEN
- PIN 12 - OPEN THERMISTOR
- PIN 14 - FF THERMISTOR 5 VDC
- PIN 16 - FF THERMISTOR

- PIN 1 - COND FAN 12 DC +
- PIN 2 - COND FAN GND
- PIN 3 - COND FAN PWM
- PIN 4 - COND FAN RPM
- PIN 5 - MAIN BRD HTR -
- PIN 6 - MAIN BRD HTR 12VDC+
- PIN 7 - FINVERTER SIGNAL -
- PIN 8 - INVERTER SIGNAL +
- PIN 9 - AMBIENT THERMISTOR 5 VDC+
- PIN 10 - HUMIDITY 5 VDC +
- PIN 11 - AMBIENT THERMISTOR
- PIN 12 - HUMIDITY SENSOR SIGNAL
- PIN 13 - MUMIDITY SENSOR GND

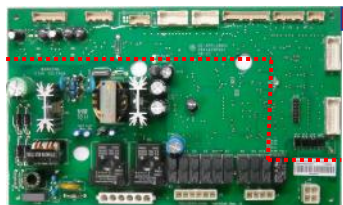
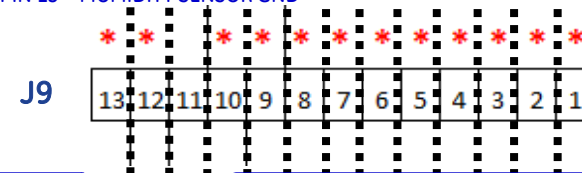

- PIN 6 - FF LED s -
- PIN 7 - FF LEDs +

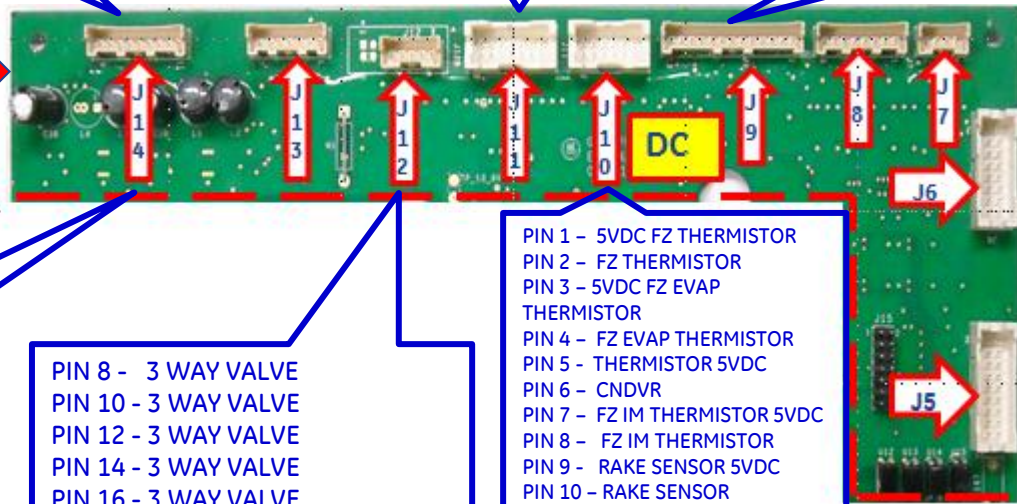
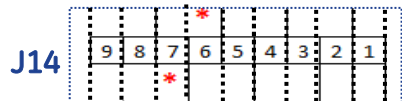

- PIN 8 - 3 WAY VALVE
- PIN 10 - 3 WAY VALVE
- PIN 12 - 3 WAY VALVE
- PIN 14 - 3 WAY VALVE
- PIN 16 - 3 WAY VALVE

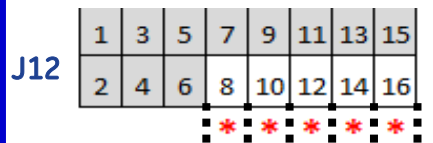

- PIN 1 - 5VDC FZ THERMISTOR
- PIN 2 - FZ THERMISTOR
- PIN 3 - 5VDC FZ EVAP THERMISTOR
- PIN 4 - FZ EVAP THERMISTOR
- PIN 5 - THERMISTOR 5VDC
- PIN 6 - CNDVR
- PIN 7 - FZ IM THERMISTOR 5VDC
- PIN 8 - FZ IM THERMISTOR
- PIN 9 - RAKE SENSOR 5VDC
- PIN 10 - RAKE SENSOR
- PIN 11 - GND
- PIN 12 - FEELER ARM SENSOR

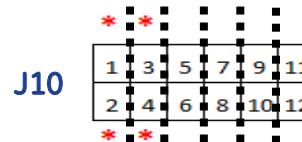

\* Indicates a wire in the connector at that location



# Main Control Board DC

continued:

PIN 1 - 12 VDC FZ FZN+  
 PIN 2 - 12 VDC ICE BOX FAN +  
 PIN 3 - GND FZ FZN  
 PIN 4 - GND ICE BOX  
 PIN 5 - PWM FZ FAN  
 PIN 6 - PWM ICE BOX FAN  
 PIN 7 - RPM FZ FAN  
 PIN 8 - RPM ICE BOX

J8

8	7	6	5	4	3	2	1
---	---	---	---	---	---	---	---

Future use

J7

4	3	2	1
---	---	---	---

Tach Gnd  
 PWM 12v  
 Conv Drawer Fan

PIN 1 - 12VDC DELI FAN +  
 PIN 2 - 12VDC FF FAN +  
 PIN 3 - GND DELI FAN  
 PIN 4 - GND FF FAN  
 PIN 5 - RPM DELI FAN  
 PIN 6 - RPM FF FAN  
 PIN 7 - PWM DELI FAN  
 PIN 8 - PWM FF FAN  
 PIN 9 - DELI DAMPER  
 PIN 10 - DELI DAMPER  
 PIN 11 - DELI DAMPER  
 PIN 12 - DELI DAMPER  
 PIN 13 - OPEN  
 PIN 14 - OPEN  
 PIN 15 - OPEN  
 PIN 16 - OPEN

J6

*	2	1	*
*	4	3	*
*	6	5	*
*	8	7	*
*	10	9	*
*	12	11	*
	14	13	
	16	15	

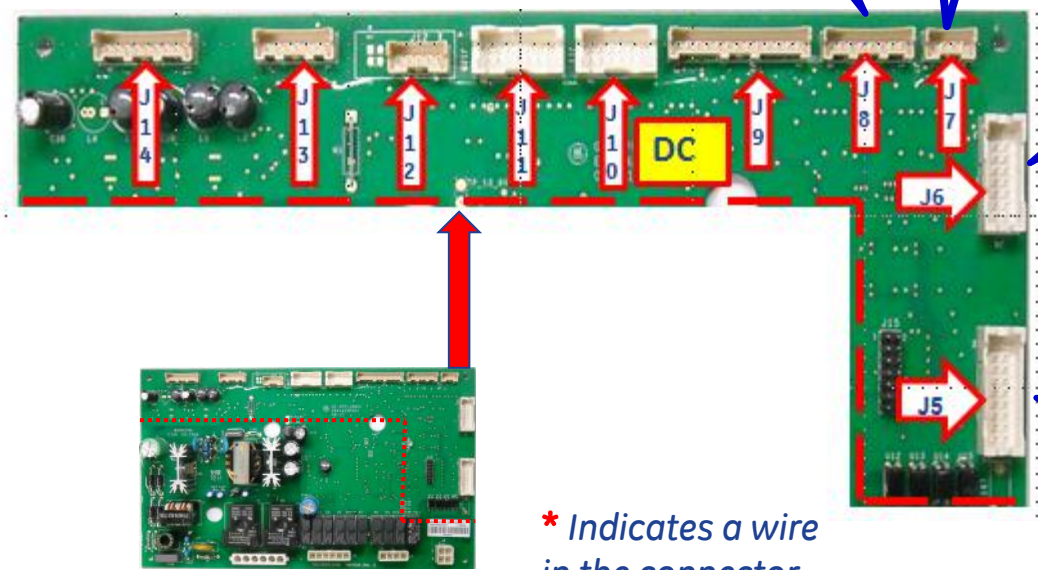

MODEL ID J5

Extra PWM Out	2	1	Extra PWM Gnd
Personality 0	4	3	Personality Com.
Personality 1	6	5	Personality Com.
Personality 2	8	7	Personality Com.
Personality 3	10	9	Personality Com.
Personality 4	12	11	Personality Com.
Personality 5	14	13	Personality Com.
Personality 6	16	15	Personality Com.
Personality 7	18	17	Personality Com.

\* Indicates a wire in the connector at that location

# Main Control Board AC

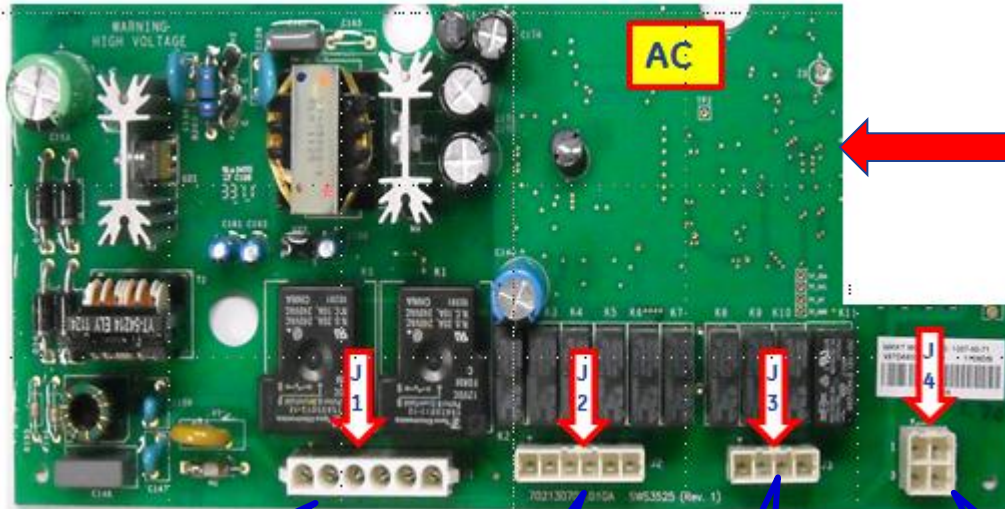

PIN 1 – HOT WATER INTERLOCK  
 PIN 2 – AC GROUND  
 PIN 3 – AC NEUTRAL  
 PIN 4 – FZ DEFROST HTR  
 PIN 5 – S SPD COMP  
 PIN 6 – AC LINE 1

J1

1	2	3	4	5	6
		*			
			*		*

PIN 1 – ISOLATION VALVE  
 PIN 2 – FF DEFROST HTR  
 PIN 3 – ICE PORT HTR  
 PIN 4 – MUL HTR  
 PIN 5 – ICE DUCT HTR  
 PIN 6 – DELI PAN HTR

J2

1	2	3	4	5	6
		*	*		
					*

PIN 1 – FZ IM RAKE MTR  
 PIN 2 – FZ IM HTR  
 PIN 3 – FZ IM WTR VALVE  
 PIN 4 – OPEN

J3

1	2	3	4
*	*	*	*
	*		

PIN 1 – LEFT FF DOOR SW  
 PIN 2 – FZ DRAWER SW  
 PIN 3 – RT FF DOOR SW  
 PIN 4 – OPEN\*

J4

1	2
3	4
	*
*	

\* Indicates a wire in the connector at that location

# PFE29PS Main Board Schematic

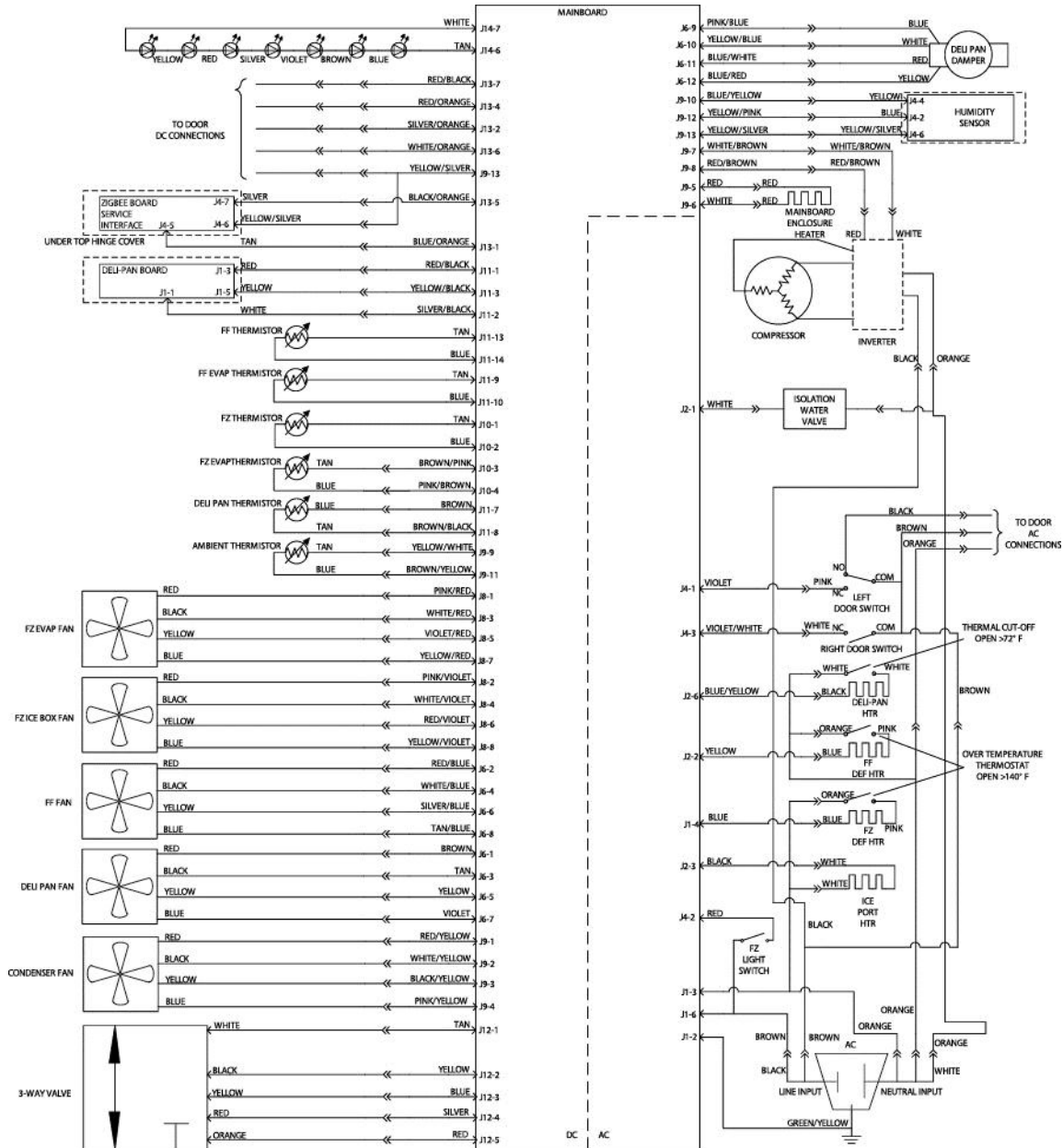

# Door Control Board

# Door Control Board

The door control board operates some or all of the following outputs depending on the model identification used:

## A/C outputs:

- Dispenser water valve
- Ice in door icemaker heater
- Ice in door icemaker rake motor
- Ice in door icemaker water valve

## D/C outputs

- Auger motor
- Duct door motor
- Recess / duct door heater
- Articulating mullion heater
- Door IM fill tube heater
- Ice box gasket heater
- Freezer LED interior lighting

# Door Control Board DC

## J3

- PIN 1 - ICE BOX GASKET HTR
- PIN 2 - OPEN
- PIN 3 - FZ LED -
- PIN 4 - ART. MULLION
- PIN 5 - FZ LED +
- PIN 6 - IM FEELER AREM SENSOR
- PIN 7 - DUCT DOOR MTR +
- PIN 8 - FLOW METER
- PIN 9 - RECESS HTR
- PIN 10 - OPEN
- PIN 11 - IM EJECTOR RAKE SENSOR
- PIN 12 - PADDLE SWITCH
- PIN 13 - FILL TUBE HTR
- PIN 14 - IM SENSOR GROUND
- PIN 15 - DUCT DOOR MTR -
- PIN 16 - OPEN
- PIN 17 - 13VDC SUPPLY +
- PIN 18 - GEABUS (COMMUNICATION)
- PIN 19 - FLOW METER 5VDC
- PIN 20 - BOARD GROUND

## J3

*	*	*	*	*	*	*	*	*	*
1	3	5	7	9	11	13	15	17	19
2	4	6	8	10	12	14	16	18	20
*	*	*	*	*	*	*	*	*	*

## J5

- PIN 1 - IM THERMISTOR
- PIN 2 - 5VDC
- PIN 3 - ICE BOX THERMISTOR
- PIN 4 - 5VDC
- PIN 5 - HOT WATER 1
- PIN 6 - 5VDC
- PIN 7 - HOT WATER 2
- PIN 8 - HOT WATER LED

## J5

1	2	3	4	5	6	7	8
*	*	*	*				

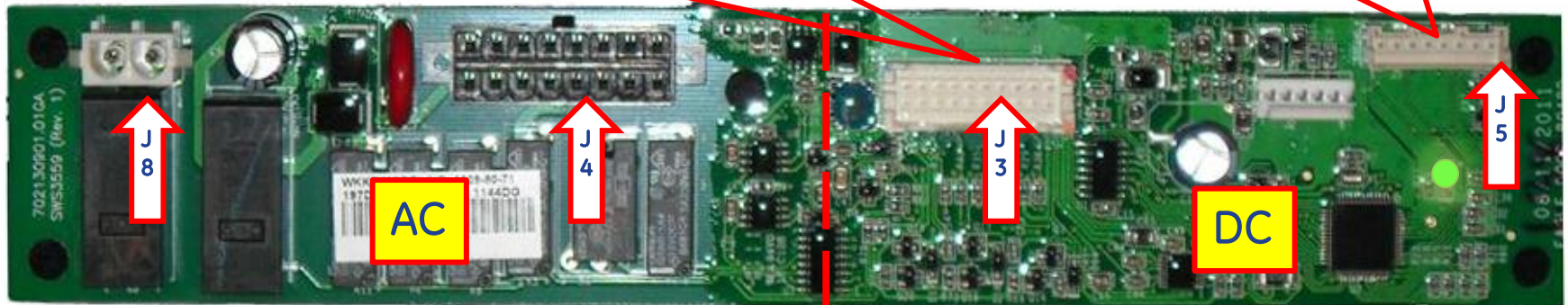

A blinking green LED means the board's DC power supply is on and operating.

\* Indicates a wire in the connector at that location

# Door Control Board AC

THIS WILL BE THE HEATER CONNECTOR FOR HOT WATER ON CAFÉ MODELS

**J8**

2	1
---	---

- PIN 1 - L1 A/C POWER SUPPLY
- PIN 2 - IM RAKE MOTOR
- PIN 3 - IM WATER VALVE
- PIN 4 - SWITCHED L1 AUGER INPUT
- PIN 5 - OPEN
- PIN 6 - AUGER MOTOR DC -
- PIN 7 - DISPENSER WATER VALVE
- PIN 8 - AUGER MOTOR DC+
- PIN 9 - IM MOLD HEATER
- PIN 10 - OPEN
- PIN 11 - OPEN
- PIN 12 - OPEN
- PIN 13 - OPEN
- PIN 14 - OPEN
- PIN 15 - OPEN
- PIN 16 - A/C NEUTRAL

**J4**

*							*
16	15	14	13	12	11	10	9
8	7	6	5	4	3	2	1
*	*	*		*	*	*	*

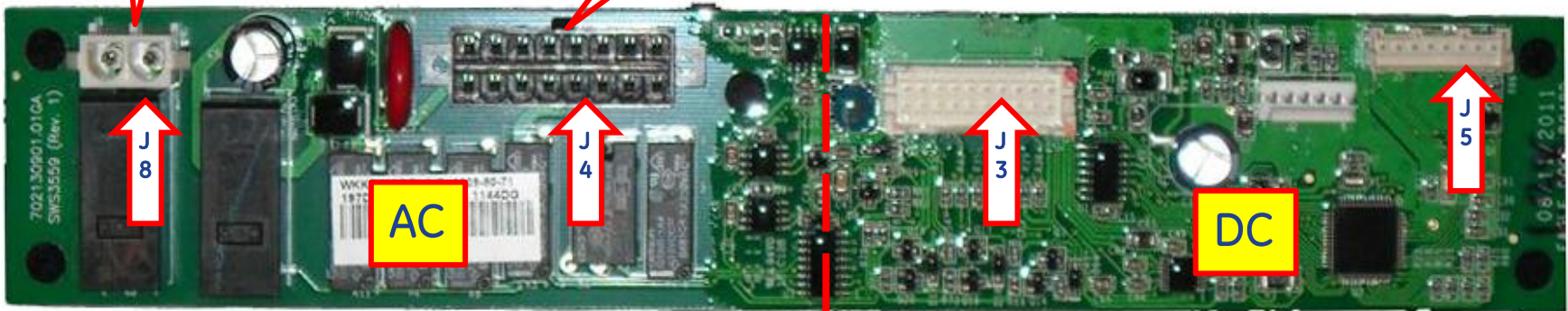

\* Indicates a wire in the connector at that location

# Door Control Board

The dispenser board controls all AC and DC functions of the left hand fresh food door. This board is accessed at the top of the door after removing the three cover screws.

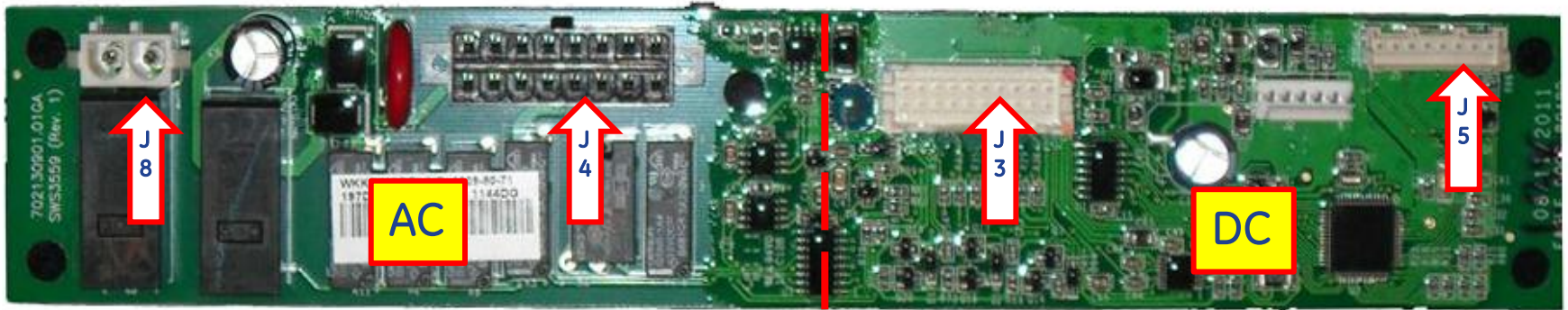



# PFE29PS Door Schematic

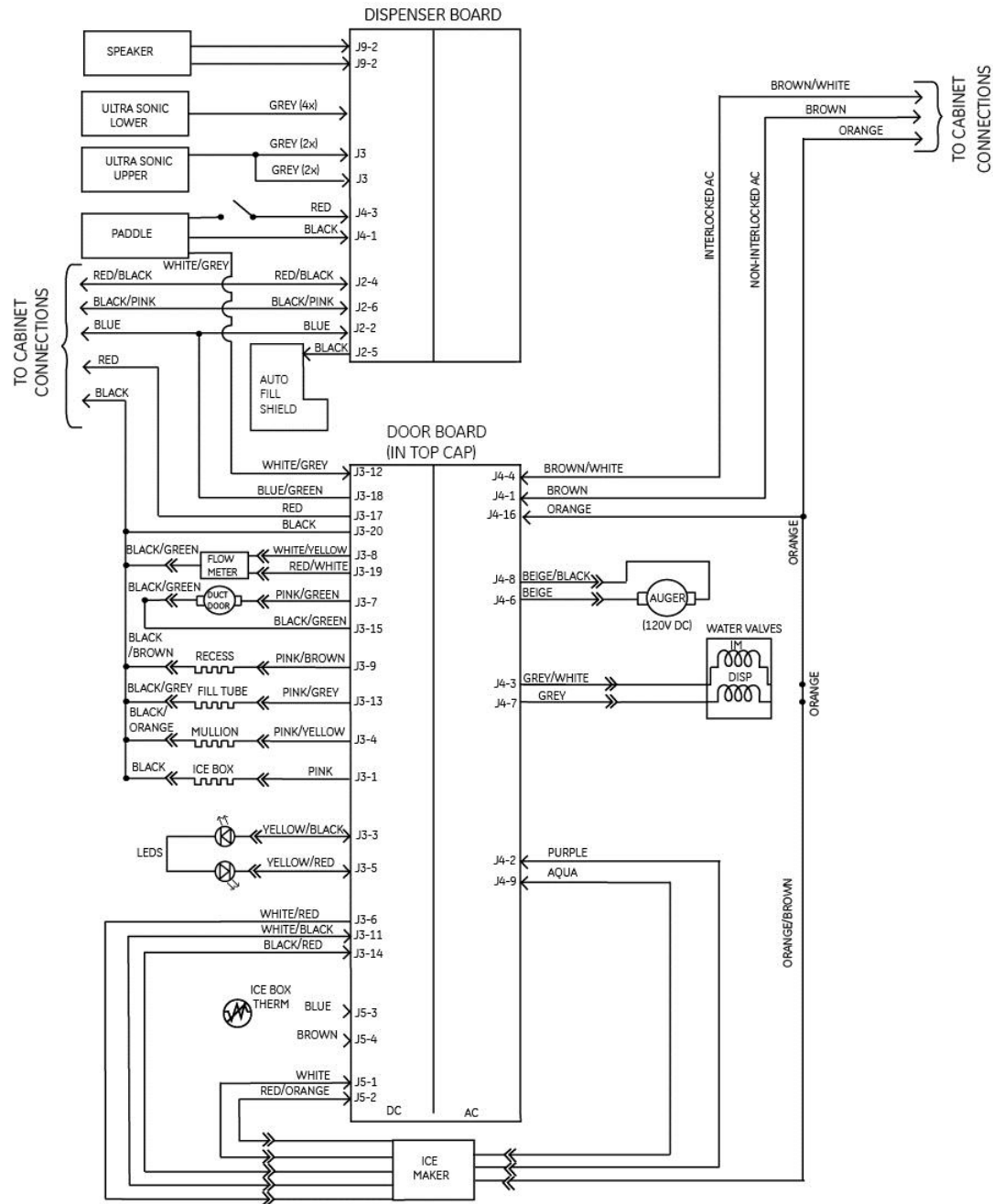

# Door Control Board Block Diagram

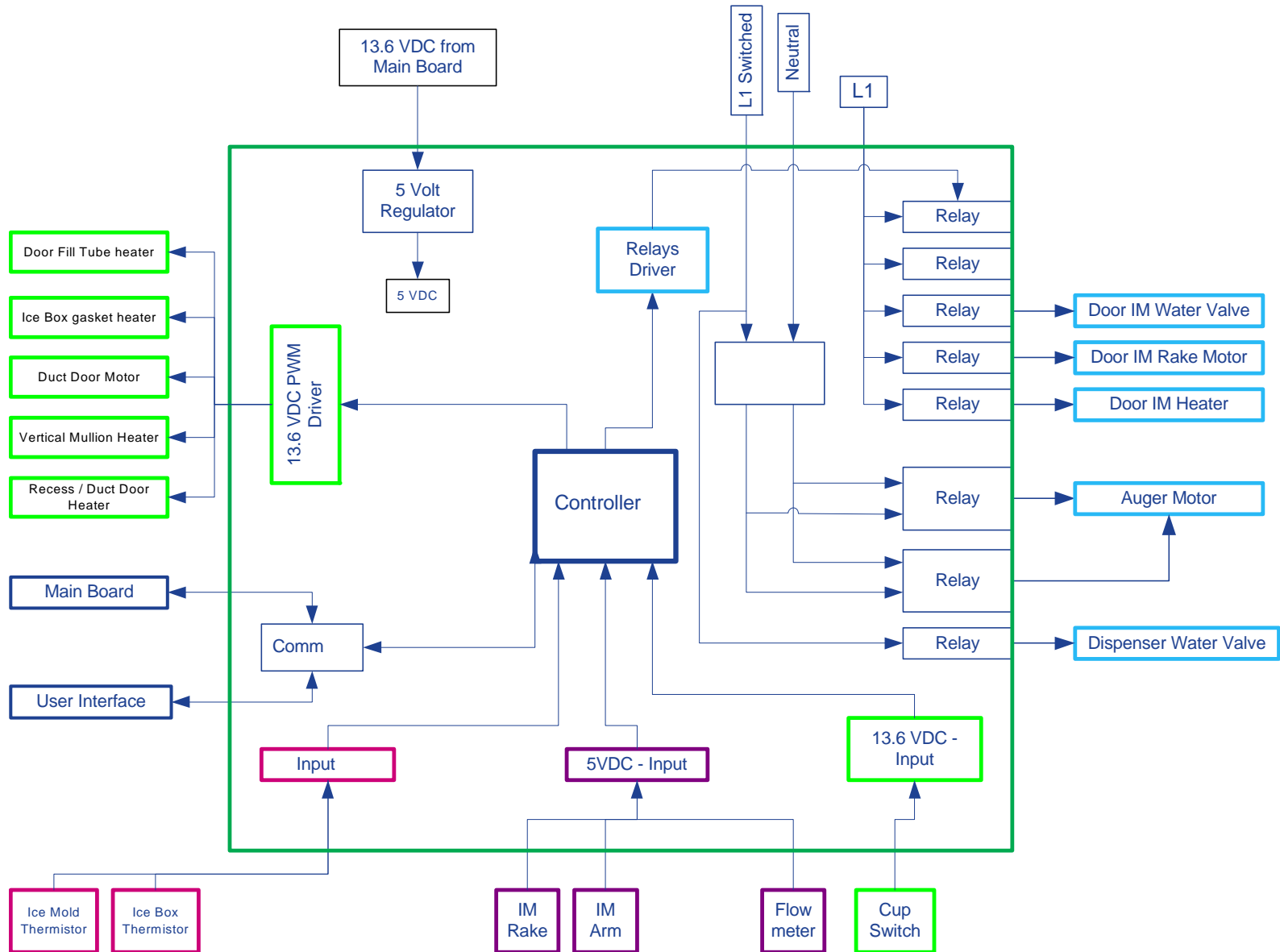

# Dispenser Door Components

# Ice-in-Door Components

- Icemaker assembly
- Auger bucket assembly
- Auger motor
- Ice box door & gasket
- Air ducts and gaskets
- Water tank
- Water valve
- Flow meter
- Water filter
- Water filter manifold
- LCD/LED control assembly
- Duct door
- Duct door motor
- Ice funnel
- Ice & water paddle and switch assembly
- Door control board
- Sensor fill components
- Freezer drawer LEDs
- Articulating mullion
- Ice box thermistor

# Ice and Water in Door

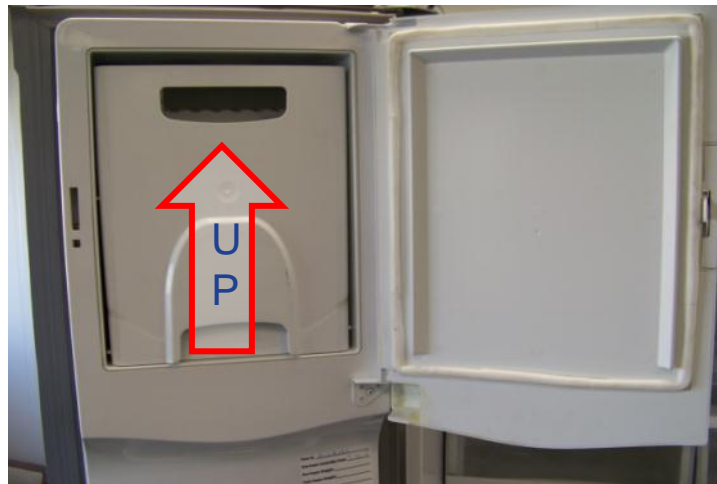
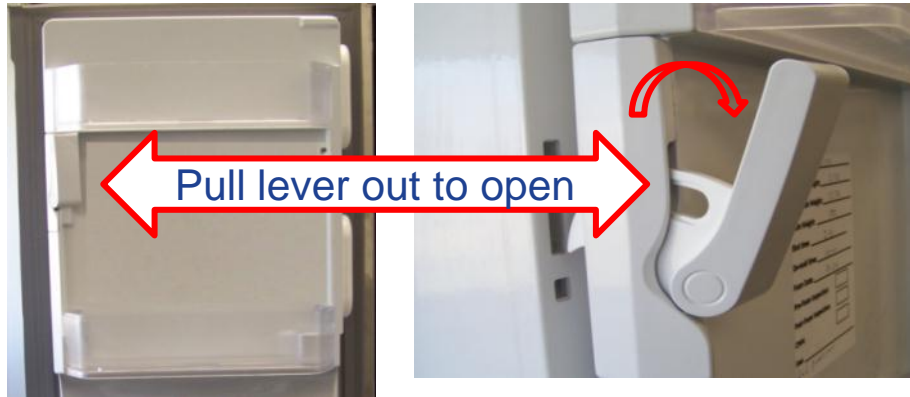

Lift slightly "up" to remove bucket



# Ice Box Door Gasket



The gasket is easily removed by pulling the retainer out of the groove

# Ice Box Air Flow



# Ice Box Ports

Ice Box air supply gasket



Ice Box air return gasket

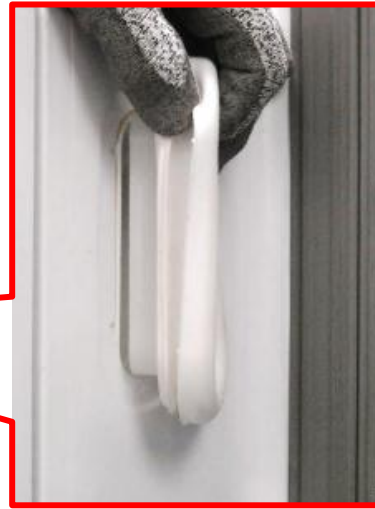

Ice Box port gaskets are removed by pushing inward with a putty knife to release the retainer tab from the duct groove.



# Auger Bucket

CCW FOR CRUSHED ICE

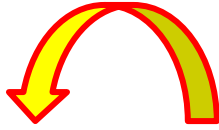

CW FOR CUBED ICE

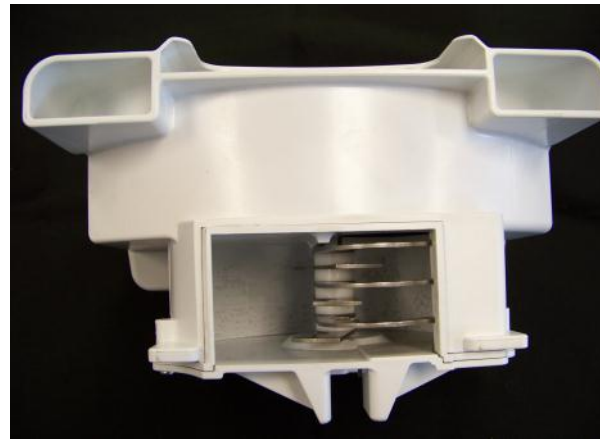
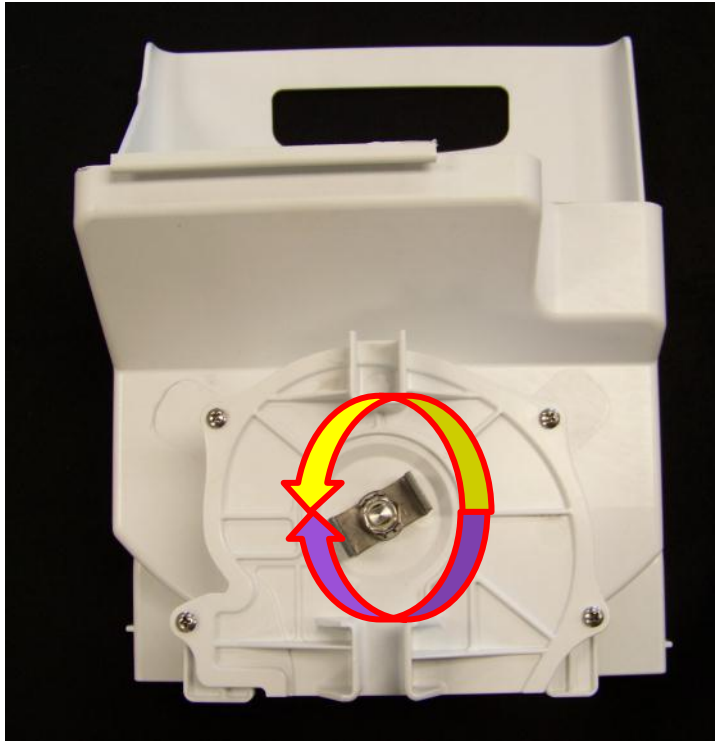
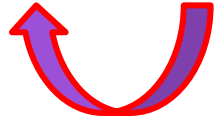

# Ice Box Components

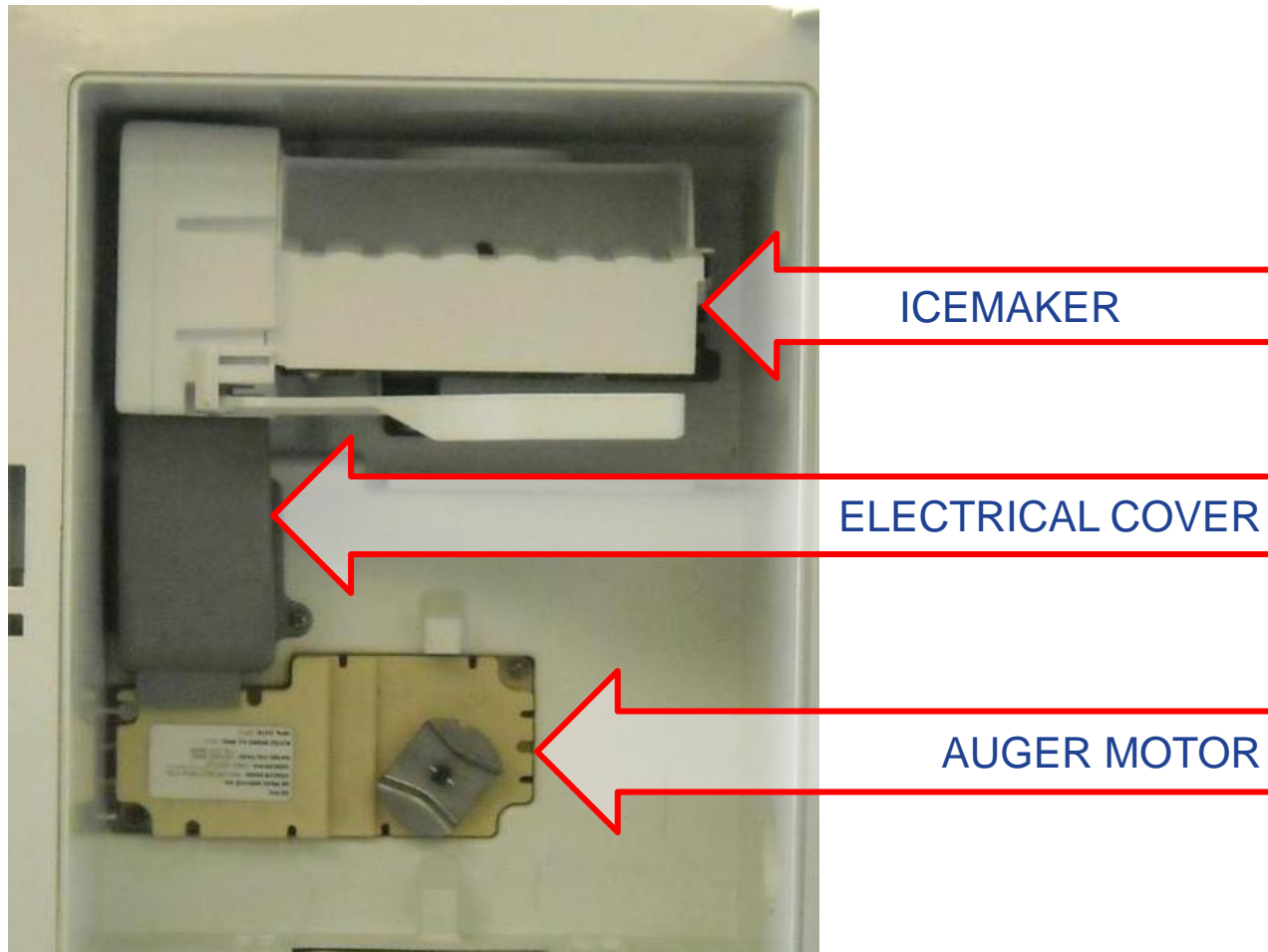

Prior to working on the ice maker and associated components, GE Factory Service Technicians are required to properly lockout the unit and control the cord. That may require the application of the LOTO box, lock and tag.

# Ice Box and Icemaker Thermistors

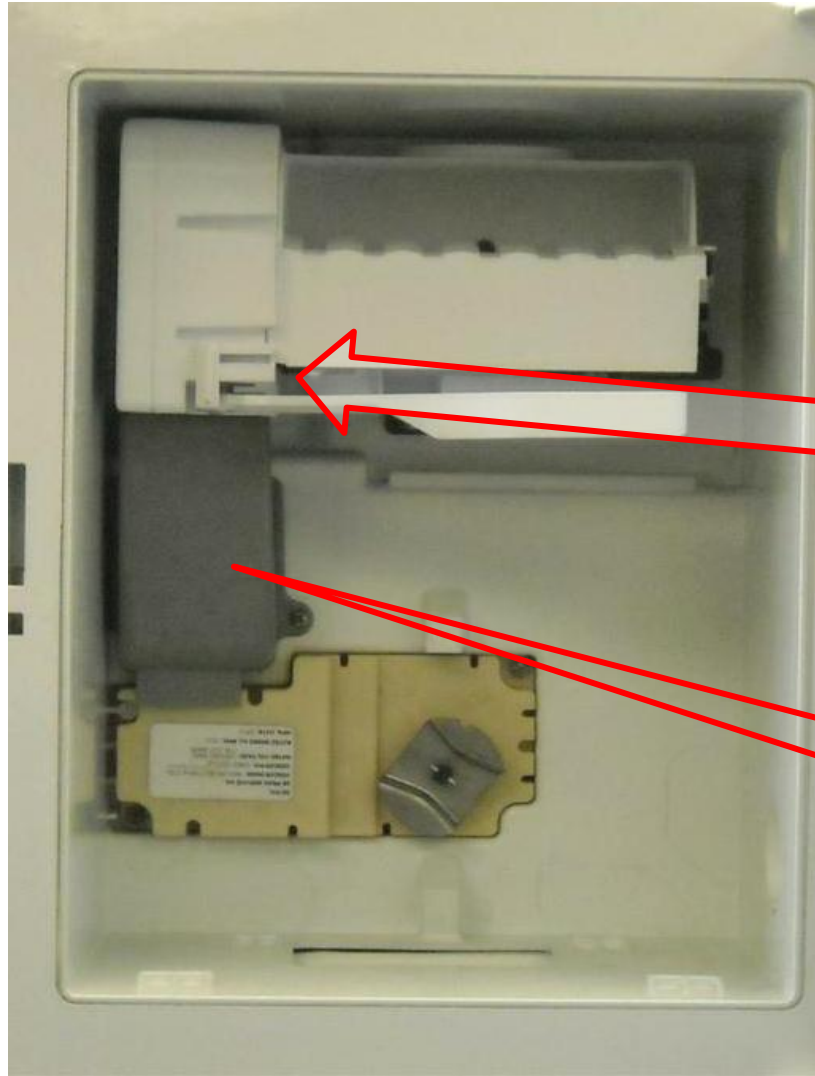

**Both Ice Box and freezer icemakers contain thermistors**

**Ice Box thermistor located in the electrical cover**

# Icemakers

- The icemakers are similar to previous icemaker designs.
- Although similar, they are NOT interchangeable with each other (between door and freezer models) or any other service icemaker!

PFE29/GFE29 ICEMAKER  
door mounted



GFE29 ICEMAKER  
freezer mounted

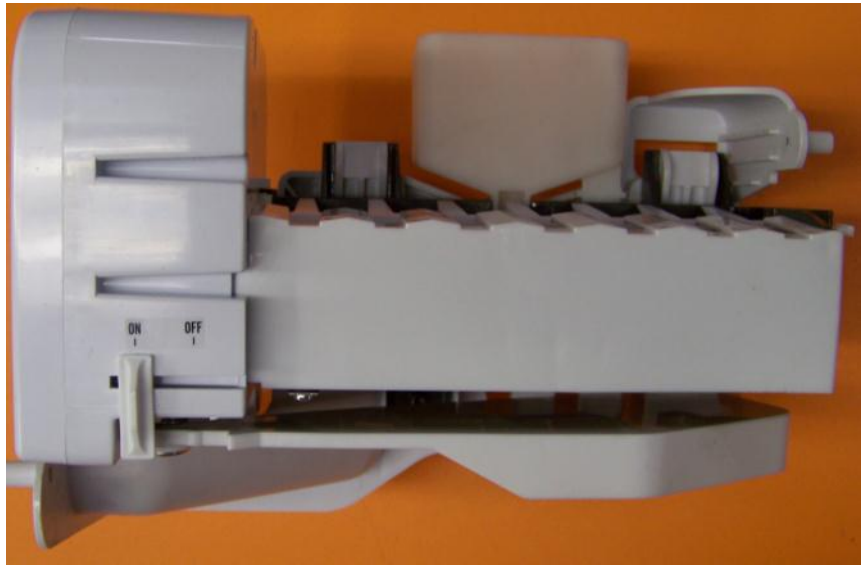

# Icemakers

- The icemakers operate in much the same way as previous bottom freezer models with one significant difference: the icemakers are controlled by either the main control board or the door control board. The board inside the icemaker does NOT control operation.
- The icemaker in the door is controlled by the door control board.
- The icemaker in the freezer is controlled by the main control board.
- These boards will monitor the mold thermistor, rake and feeler arm sensors to operate the rake motor, heater and water valve.
- Like previous electronic icemakers, these new icemakers will run “Power On Diagnostics”, however, this will occur if the mold temperature is above 40°F\* rather than 50°F like previous models.
- The thermistor has the same resistance value as previous electronic icemakers.

The icemaker thermistor has a negative coefficient. That is, an increase in temperature will cause a decrease in resistance. The chart below shows the most common values used by the electronic control.

°F	°C	Ω
-40	-40	207K
35.6	2	25.37K
39.2	4	23.27K
50	10	18.07K
59	15	14.75K
68	20	12.11K
77	25	10K
176	80	1.67K

\* Values are approximate and preliminary

# Icemakers

## Power On Diagnostics

If the icemaker thermistor temperature is 40°F (4.4°C) or higher\* when the icemaker is connected to power, the control will perform a Power On test before entering the freeze cycle.

The test consists of the following:

- Turn on the motor and rotate until it reaches home again
- Turn on the water valve for 1/2 second
- Turn on the heater for 1/2 second
- Verify that the feeler arm was in the “IN” and then in the “OUT” position
- Verify the motor was rotating by checking the motor was not in the home position and then returned to the home position
- Verify the motor does not remain on after being turned off
- Proceed to the freeze cycle

\* Values are approximate and preliminary

# Icemaker Sequence

- The normal icemaker sequence is to fill the mold with water, wait until the water is frozen, harvest the ice and then repeat the cycle.
- To accomplish this sequence, three cycles are defined:  
**Freeze, Harvest and Water Fill.**
- The **Freeze** cycle begins after a fill, when the mold temp drops below **32°F\*** and will last for a minimum of **50 minutes\***.
- After the Freeze cycle conditions have been met and the feeler arm is in the “out” position, a harvest cycle will be initiated.
- At the start of the **Harvest** cycle, the heater will turn on and remain on until the mold temperature is at least **36°F\* (minimum heater time is 1 minute)\***. The heater will cycle to maintain at least **36°F\*** during harvest.
- Once **36°F\*** is reached, the rake motor will turn on, making one revolution to eject the cubes while the control monitors rotation through the home position.
- When the rake motor is back at the home position, the **Water Fill cycle** starts by cooling the mold to **40°F\***.
- The icemaker then fills with water for **5.1 seconds (no additional fills are used)\***
- The icemaker then starts another Freeze cycle.
- Average time from fill to fill is 60-70 minutes.

# Icemaker Diagnostics

- At any time during the first 15 seconds of power up, the service diagnostic test may be entered.
- The service test is entered by pushing the feeler arm from the “out” position to the “in” position and back again 3 times within 15 seconds (only 3 times!).  
*Note: If the icemaker had already started into the harvest cycle before being disconnected from power, it may be impossible to properly move the arm.*
- The service test will consist of a harvest cycle followed by a water fill cycle.
- The harvest cycle will be entered immediately, regardless of mold temperature or feeler arm position.
- The mold heater will be turned on for a minimum of 20 seconds.
- At the end of the harvest cycle, a water fill cycle will be initiated for 5.1 seconds\*
- After the water fill cycle, the icemaker will enter the freeze cycle.
  
- *During the service diagnostic test, the feeler arm position sensor and motor position sensor are tested by the control board software. The motor and water valves are energized and can be visually observed for diagnostic purposes.*

\* Values are approximate and preliminary



# Icemaker Schematic

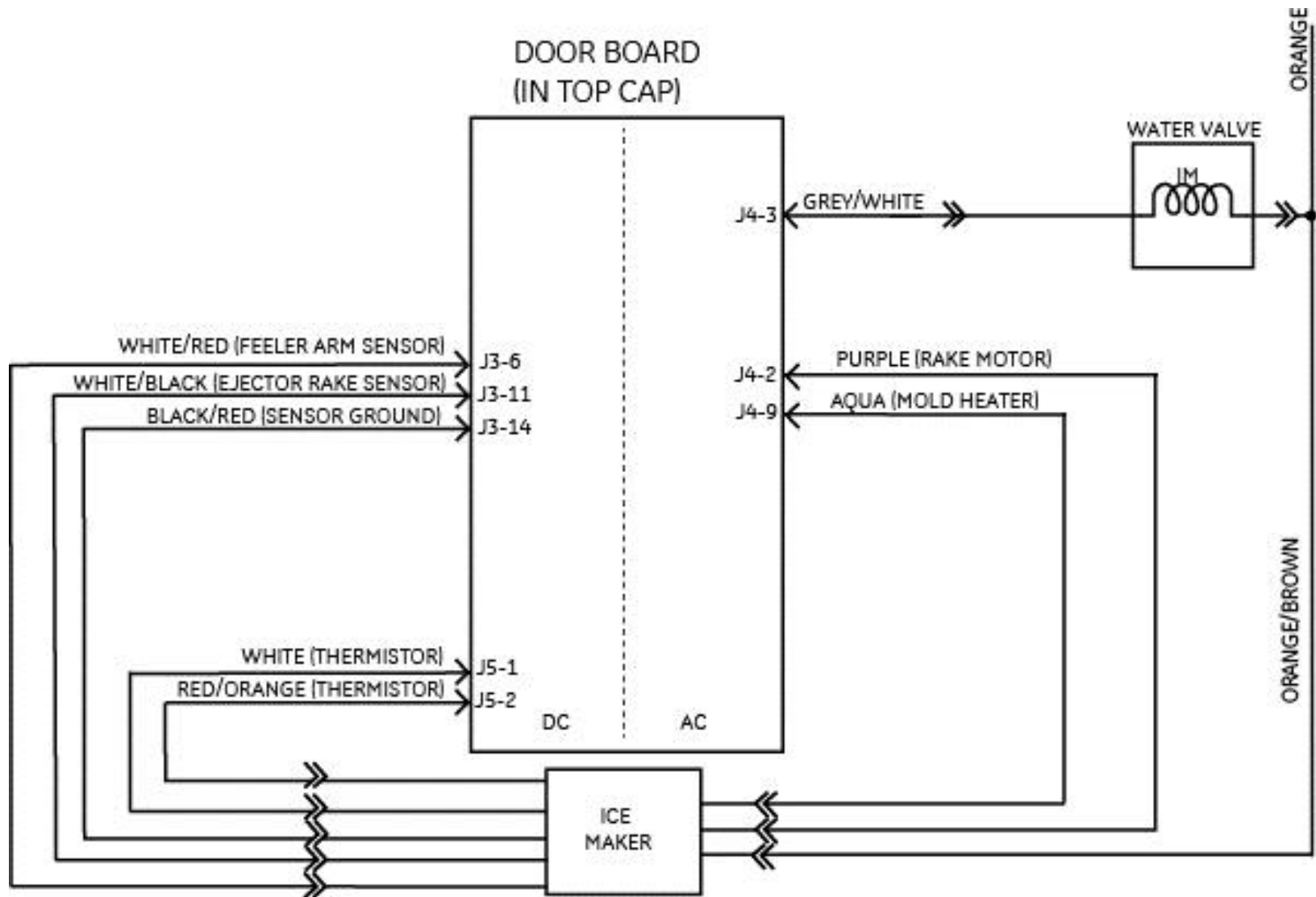

# Ice Box control

- The door control board monitors the ice box thermistor to control temperatures in the ice box.
- The ice box fan circulates cold air from the freezer evaporator through the cabinet ducting to achieve the desired temperature.
- The temperature in the ice box will vary based on the freezer set point and the state of ice production or storage.
- Based on freezer temperature and assuming the ice box has not been opened before testing, the maximum expected temperature in the ice box is shown in the table below.
- Example: At a 0°F freezer set point, the expected maximum temperature observed would be 15°F . The temperature range is approximately 5° - 15°F.

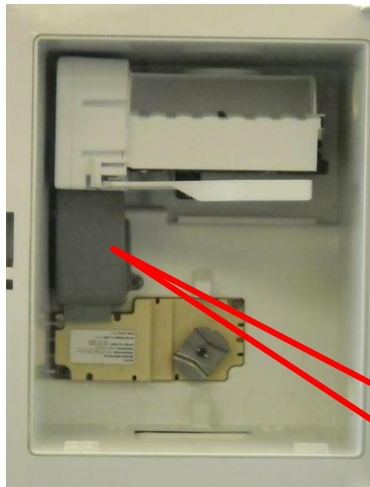

Ice Box thermistor  
is located in the  
electrical cover

FZ Set Point	IB Set Point
-6	3
-5	5
-4	7
-3	9
-2	11
-1	13
0	15
1	17
2	19
3	21
4	23
5	25
6	27
7	29
8	31

# Icemaker and Auger Motor Removal



Remove Phillips screw to expose connectors

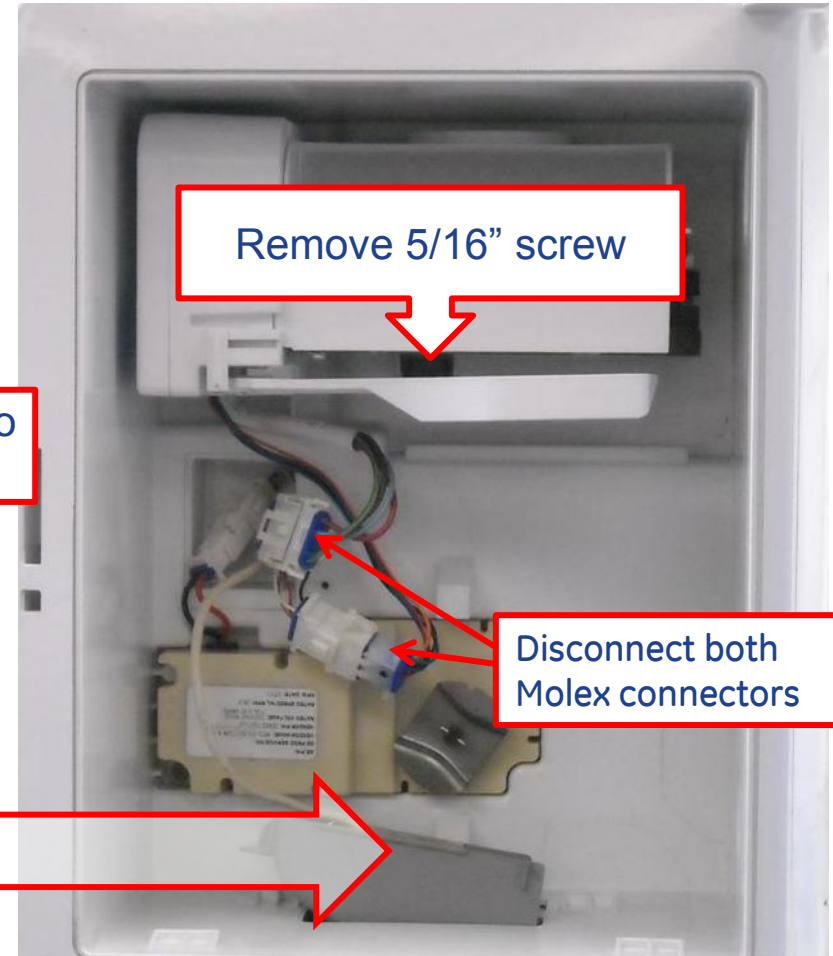

Remove 5/16" screw

Disconnect both Molex connectors

Note: Ice Box thermistor is mounted to cover

GE Factory Service Technicians are required to always wear cut resistant gloves prior to commencing the repair.

# Icemaker Removal

Lift the icemaker up  
and off of the 2  
mounting tabs

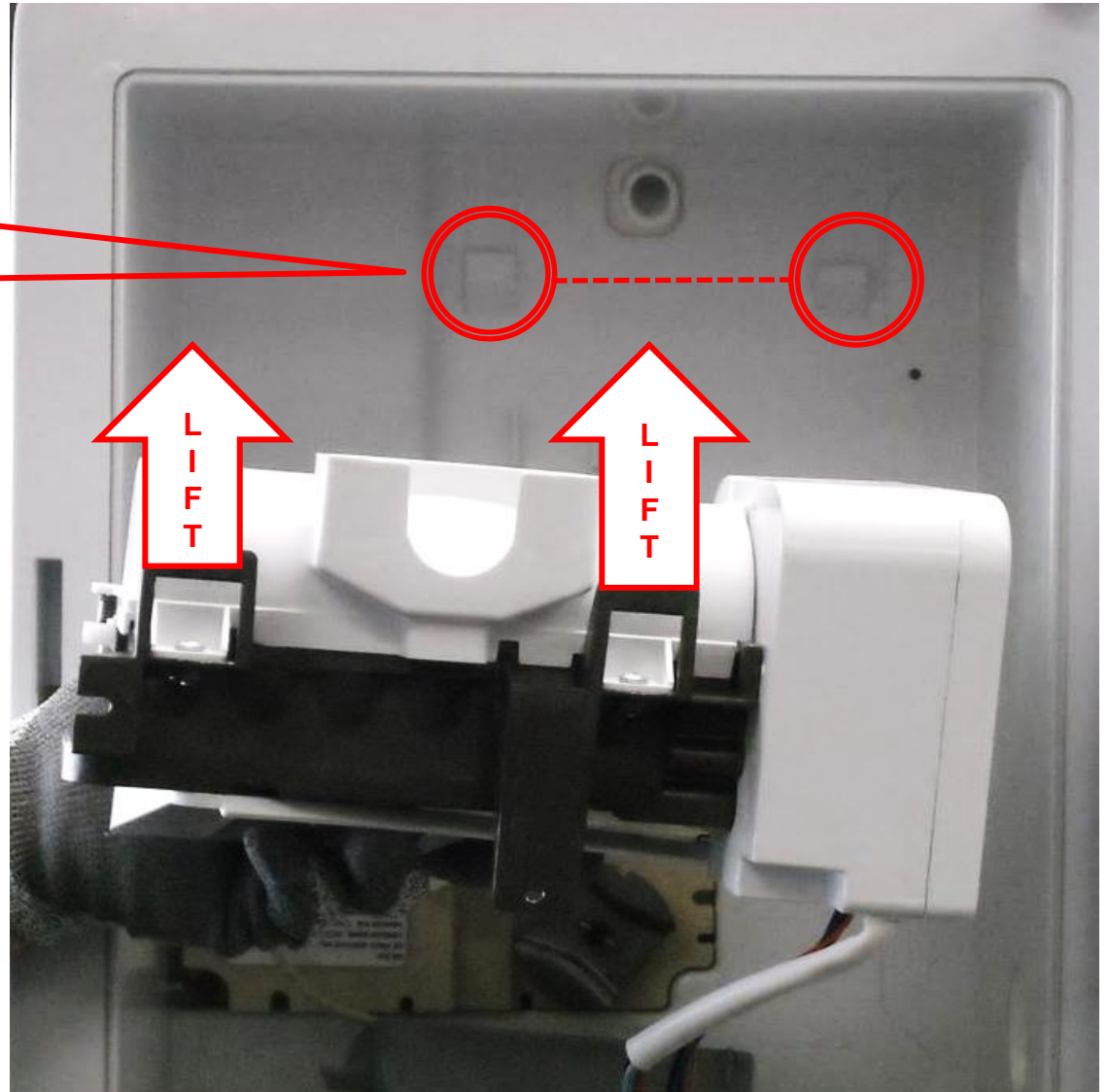

# Auger Motor Removal

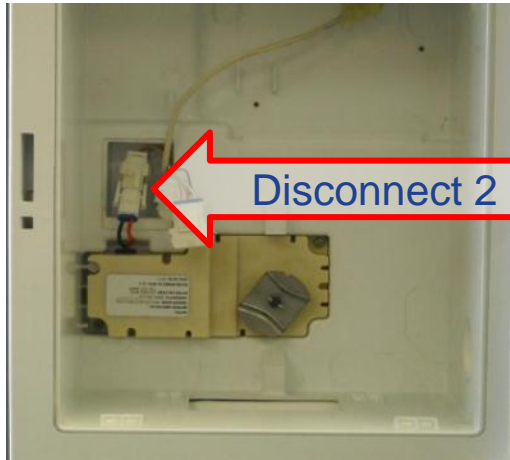

Disconnect 2 pin Molex connector



Remove Phillips screw

Pull the auger motor assembly straight out to remove

*Note: Icemaker does not have to be removed*



Remove Phillips screw

# Auger Motor Assembly

CCW FOR CUBED ICE

CW FOR CRUSHED ICE

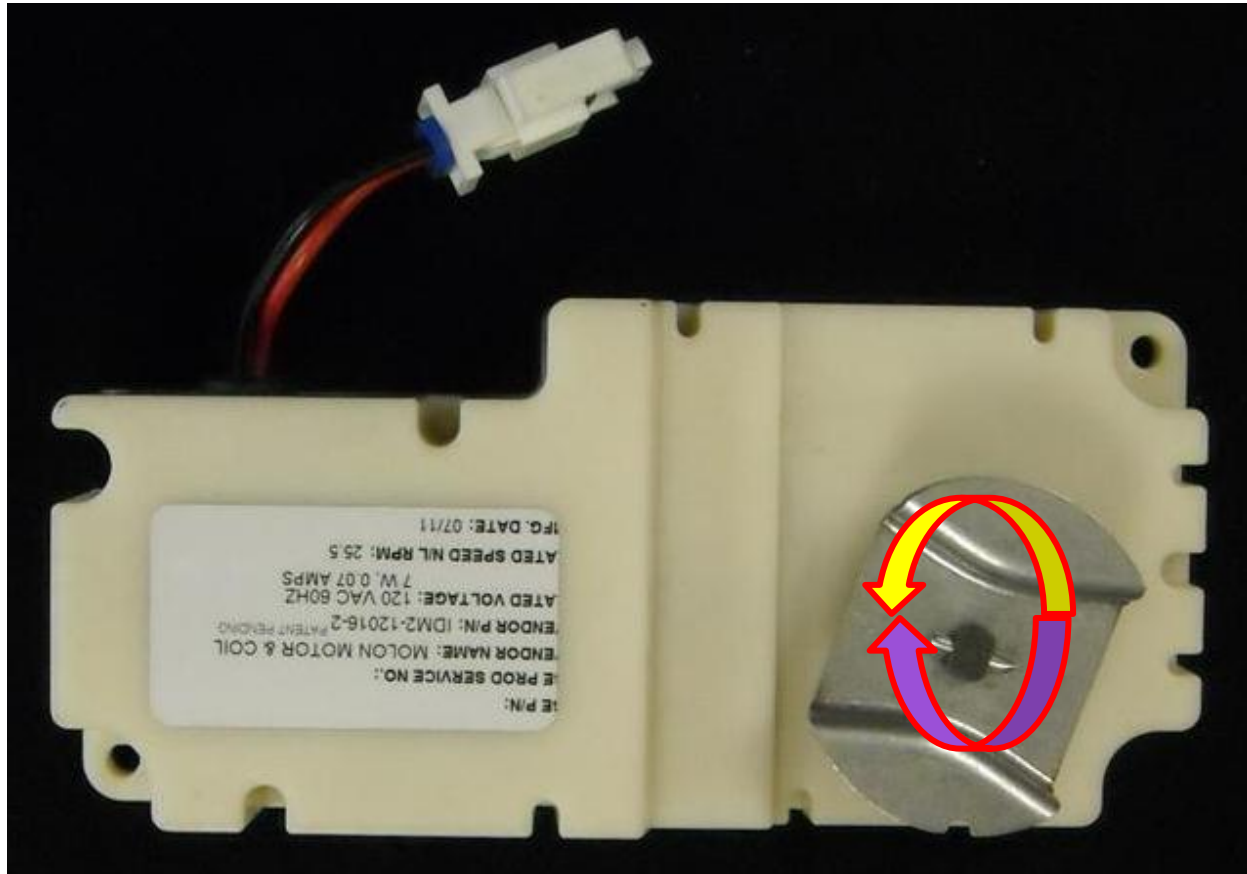
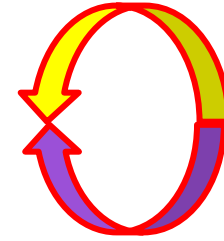

# Water Valve, Flow Meter and Water Tank

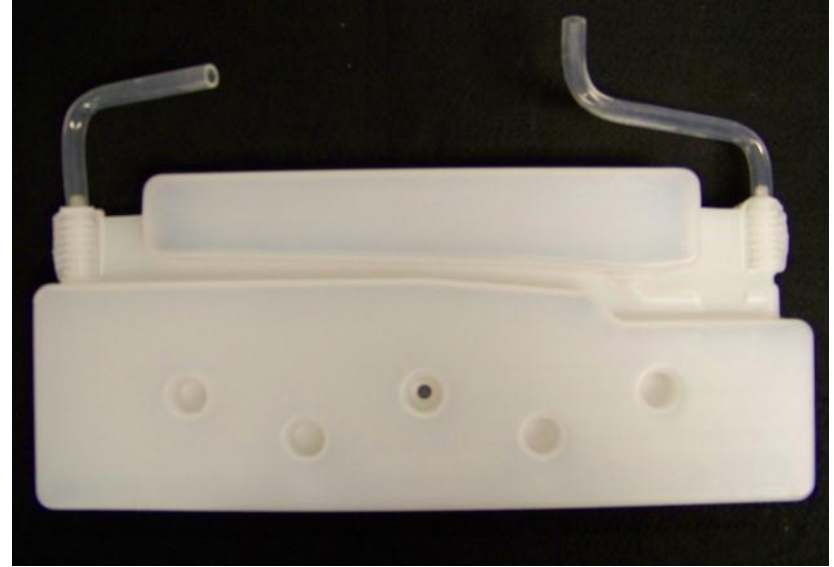
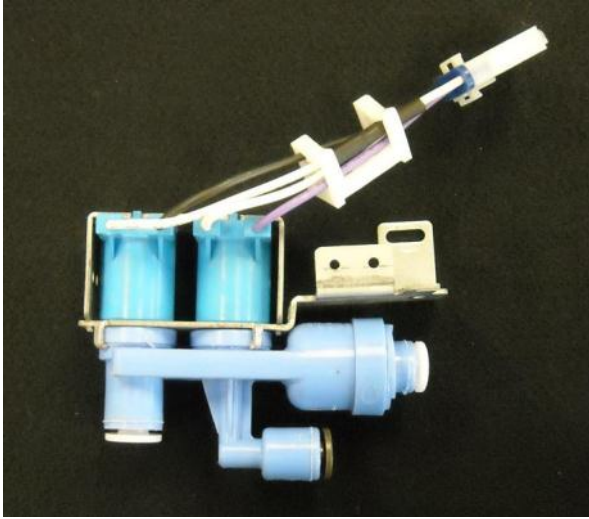

# Access Cover Removal

On the lower part of the left fresh food door, remove the three T20 screws holding the access panel

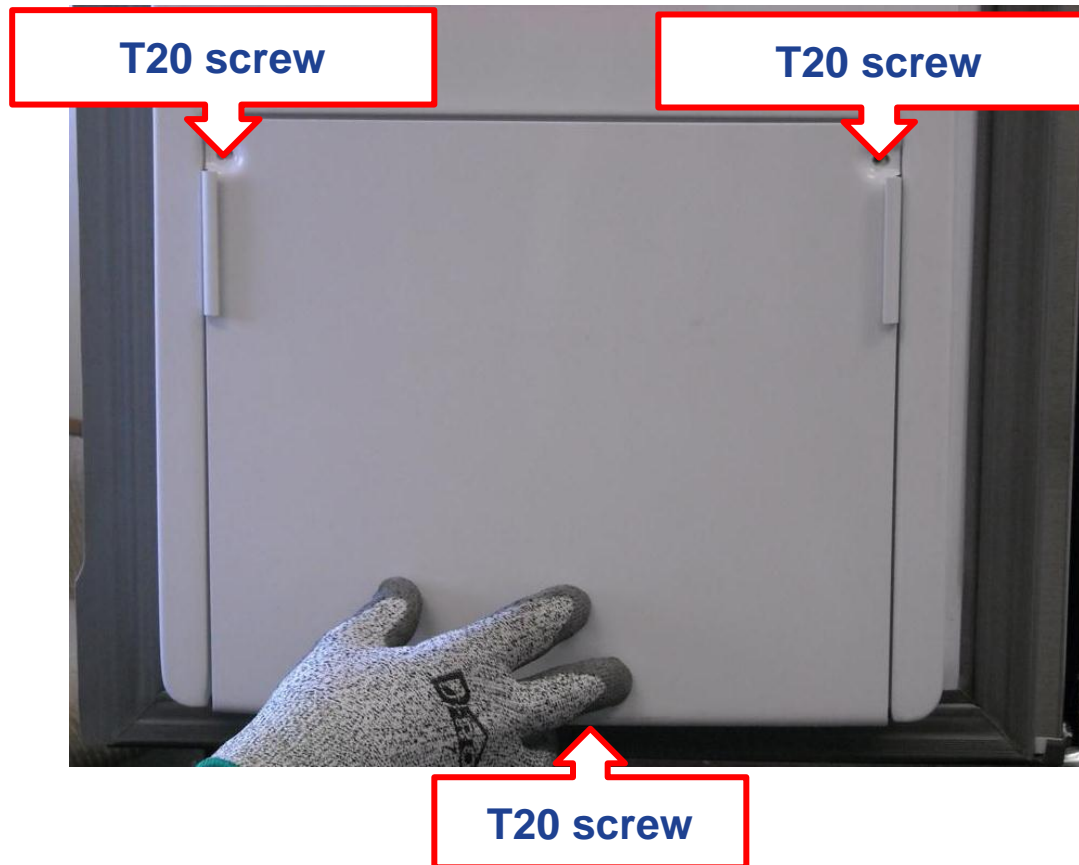



# Water Valve and Water Tank Location

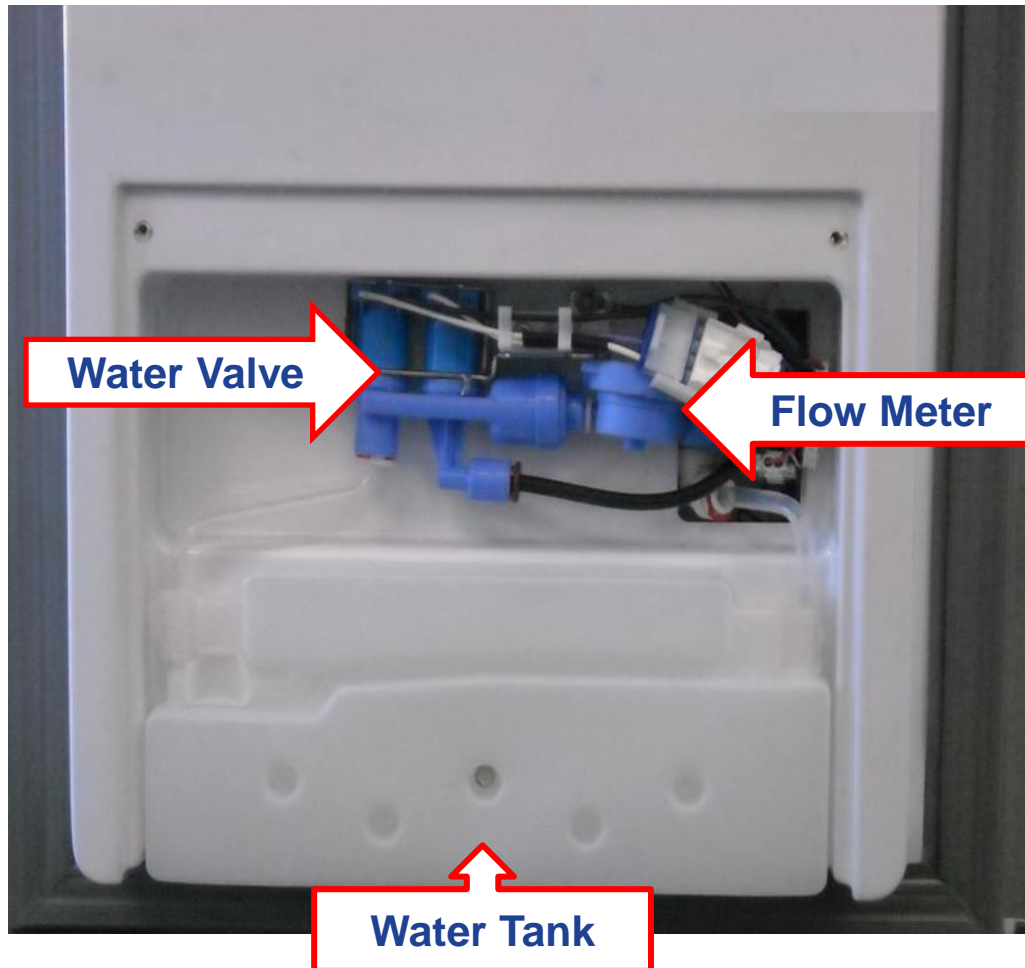

- The water valve is located in the lower part of the left fresh food door and supplies water to both the icemaker and the water dispenser.
- The flow meter operates the same as previous models with the 'Precise Fill' feature.
- The water tank capacity is 16 ounces.
- All of the quick connects have **RED** retainer clips that must be removed to disconnect tubing.

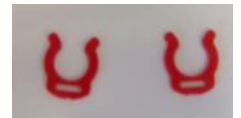

*Note: **RED** clips must be reinstalled after reinserting tubing.*

When disconnecting hose connections always use great care so that when the hose releases your hand does not forcefully contact another component in the refer.

# Water Valve and Flow Meter Assembly

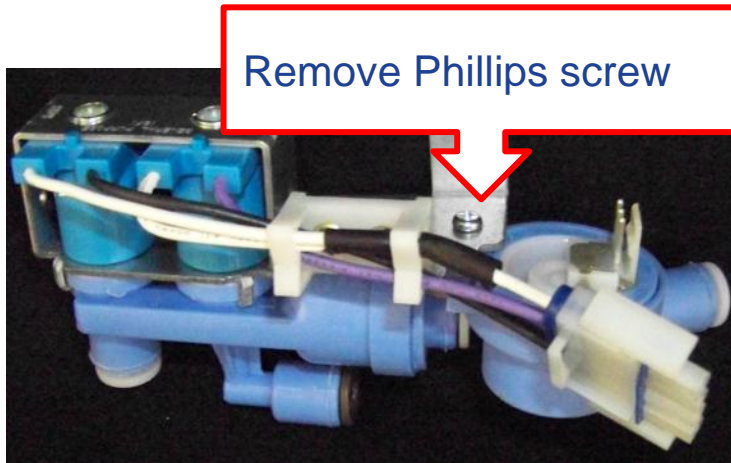

- The flow meter is attached to the water valve with a Phillips screw and quick connector.
- To separate the water valve from the flow meter, remove the Phillips screw and push in on collar to release the quick connector.



## FLOW METER

The flow meter will be available in the future as a separate part.

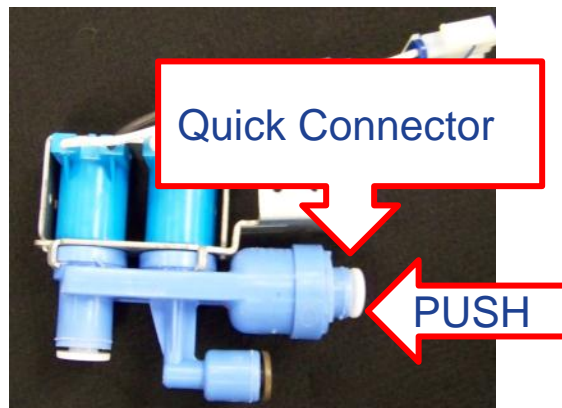

## WATER VALVE

# Water Filter Location



- The water filter is located on the right side of the left fresh food door.
- To open the filter compartment, press the bottom of the cover to release and swing open the cover, exposing the filter.

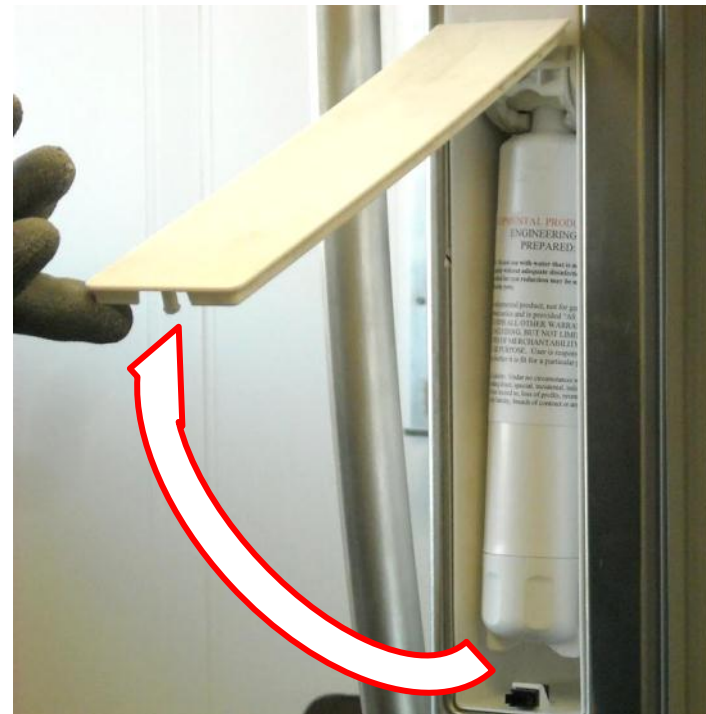

# Water Filter Removal

- Lift and rotate the water filter upward until it stops.
- Maintaining that same angle, pull the water filter straight out.  
**DO NOT TWIST OR TURN.**
- Removing the water filter turns off the water to the door water valve.
- A bypass cartridge is installed in the water filter manifold for shipping.
- The water filter should be installed when the refrigerator is delivered to the consumer.



# Water Filter Manifold Removal

Remove three ¼" screws from the top hinge cover

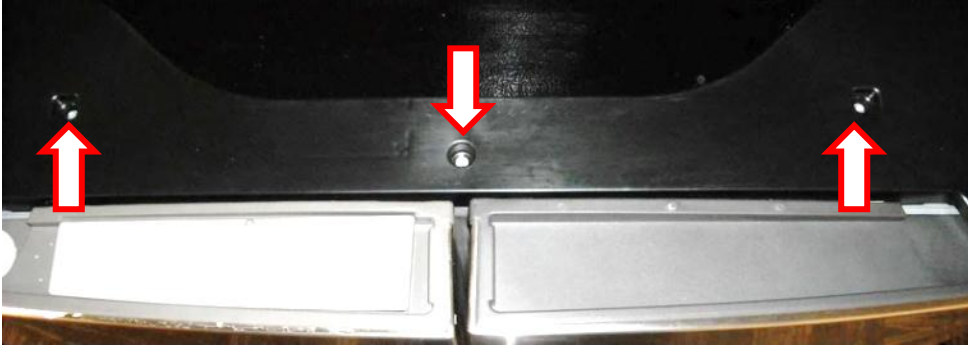

Open both fresh food doors to 90°

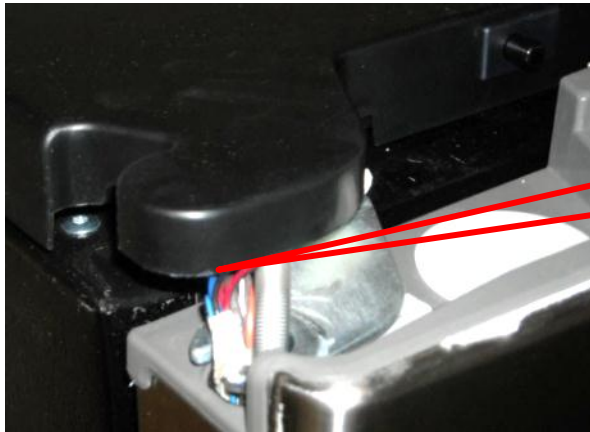

Move the cover slightly forward to release the tabs from the hinges and slide back.

# Water Filter Manifold Removal

Remove the hinge cover assembly and lay the cover back onto the cabinet to access the top hinge screws, wiring and water tubing.

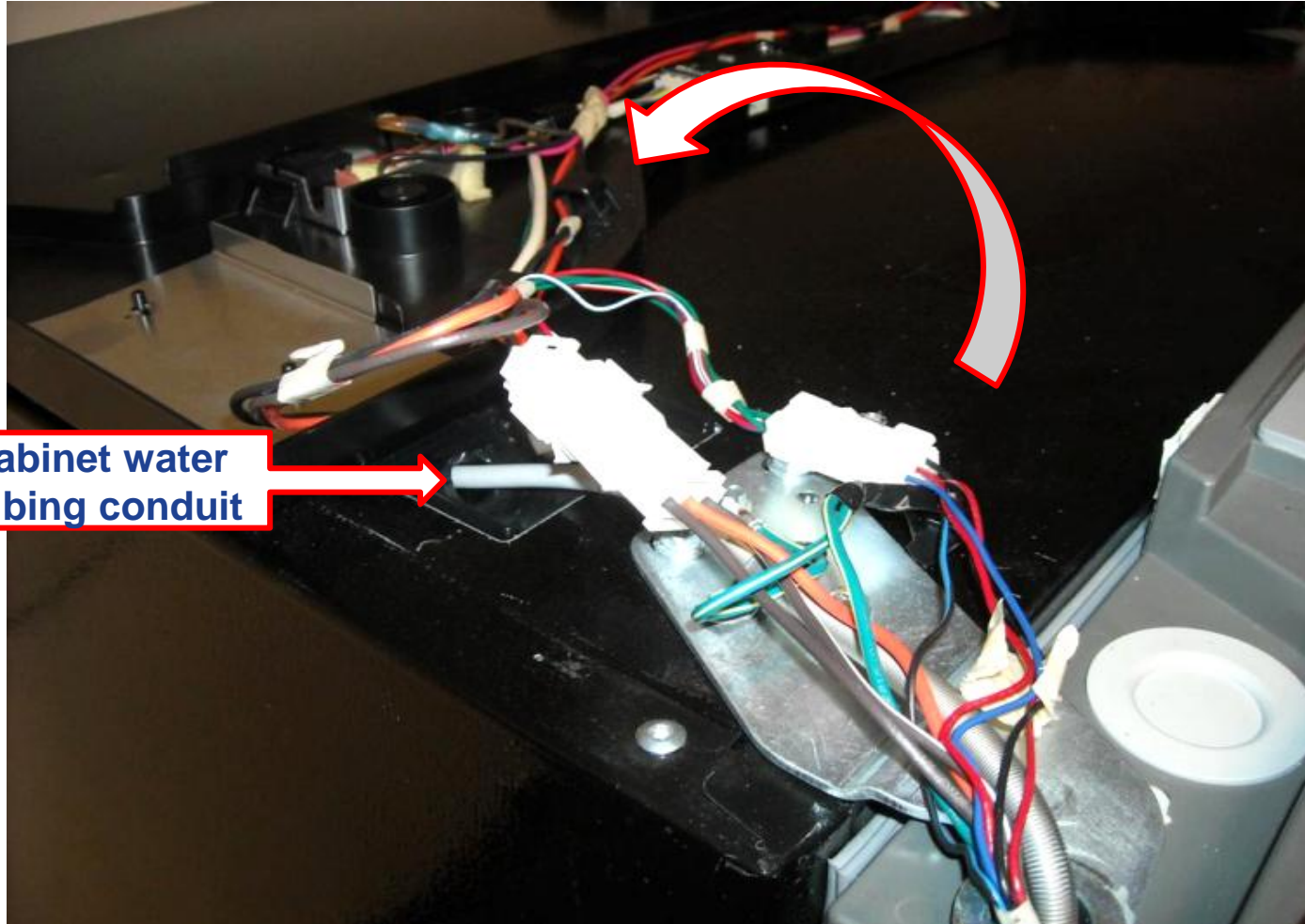

**Cabinet water  
tubing conduit**

# Water Filter Manifold Removal

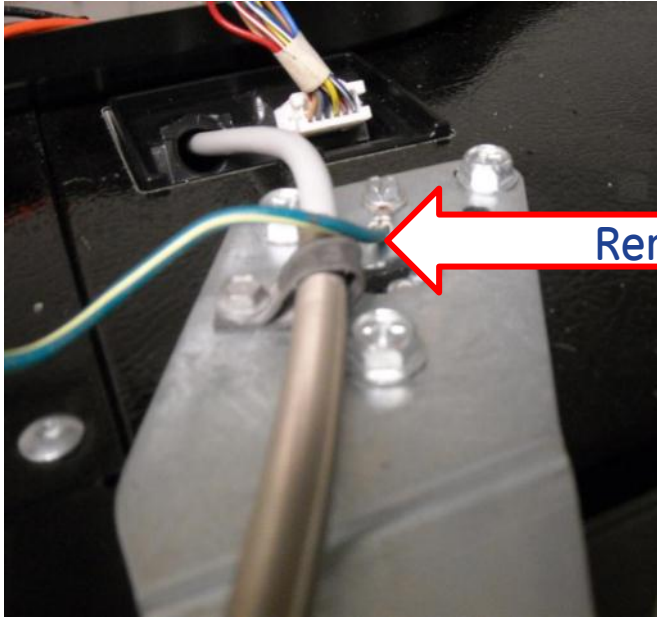

Remove the tube clamp from the hinge

Disconnect the top side of the quick connector located at the rear of the cabinet, 15" down from the top.

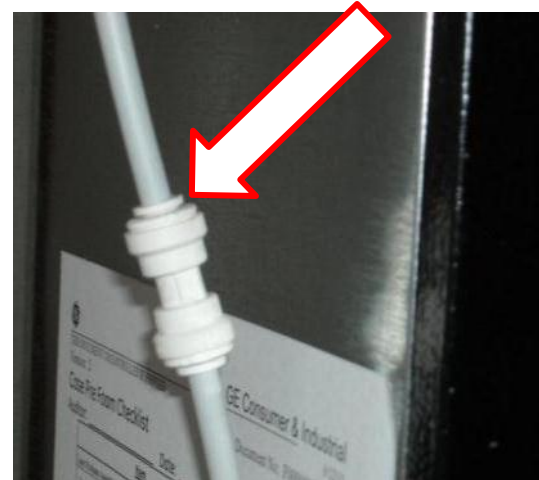

# Water Filter Manifold Removal

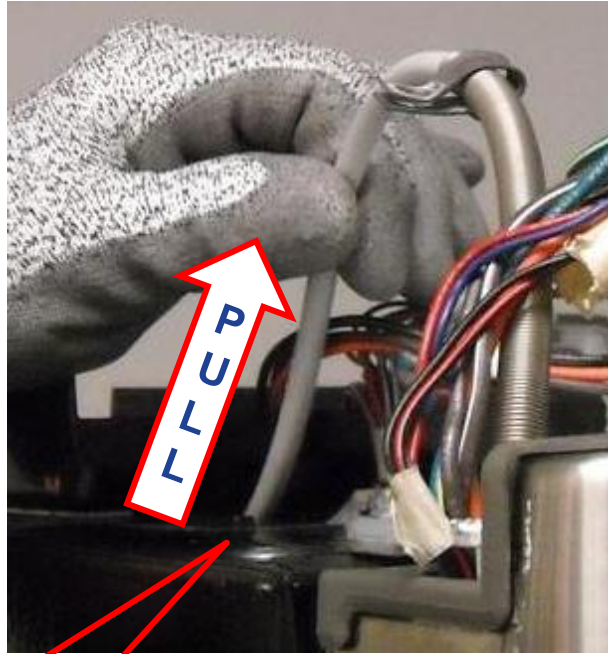

- Pull the water tubing out of the conduit.
- Slide the spring and clamp off of the tubing.

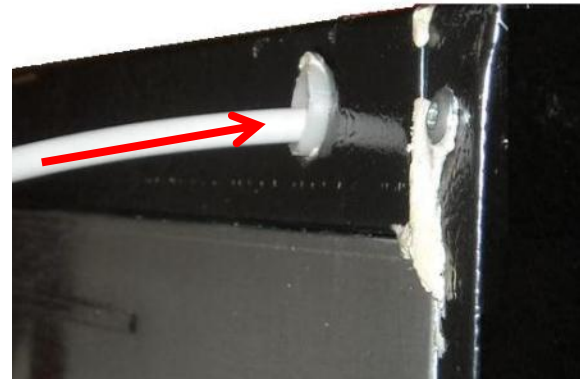



# Water Filter Manifold Removal

Pry either tab inward slightly to release and remove the cover assembly. Use tape on a small screw driver to prevent damage.



*Note: If the filter door is left open and the door is closed the assembly will pop off rather than break.*

# Filter Manifold Removal

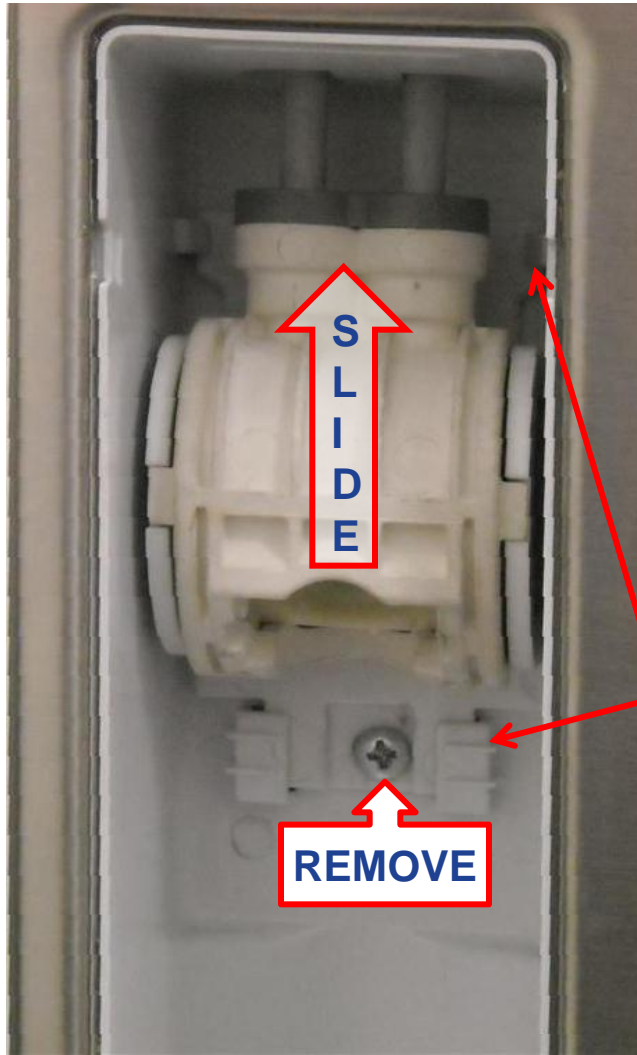

- Disconnect tubing from the flow meter inlet
- Remove the screw
- Slide the manifold up to release it from the upper and lower tabs
- Pull down to remove the tubing from the door



# Filter Manifold Assembly *(manufacturing diagram)*

NOTE: The manifold comes as an assembly

1. Outer Spool
2. Inner Spool
3. Retainer
4. Lock out stem
5. Spring
6. Ferrules
7. ¼" Outlet tube
8. ¼" Inlet tube
9. Ferrule/ Outer Spool o-rings
10. Gasket

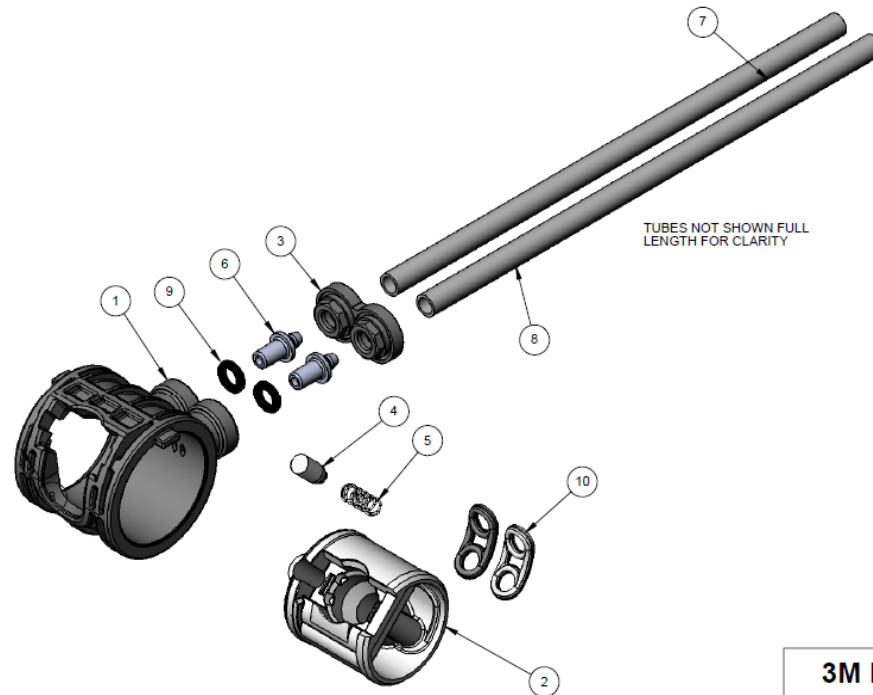

3M Purification Inc.

Note: Bypass plug and o-ring not shown

# Routing of Water Filter Manifold Tubing

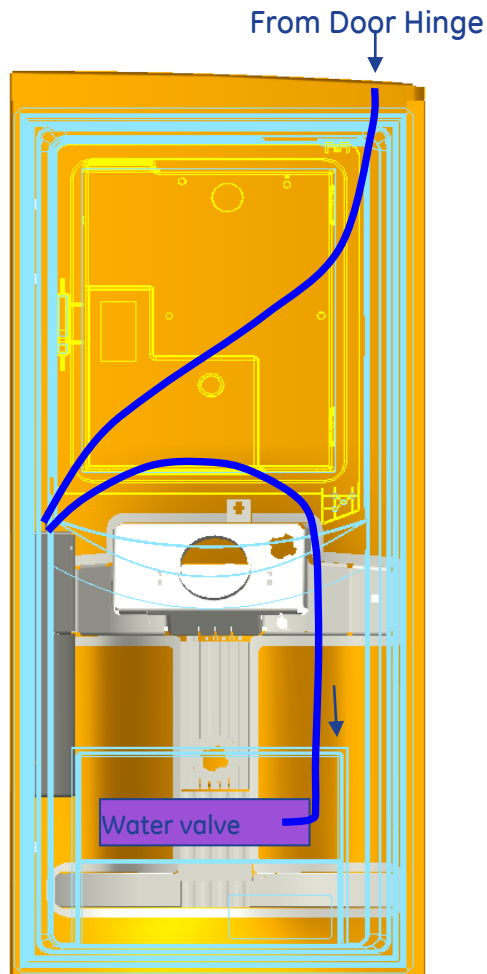

BACK VIEW



# Water Filter GFE29

- The water filter is located in the top left of the fresh food cavity
- Water is supplied from the isolation valve powered by the main control board
- The GE model uses the same water filter as the Profile



# Dispenser Access

Remove the 2 Phillips screws from the bottom of the control panel



# Ice Funnel Removal

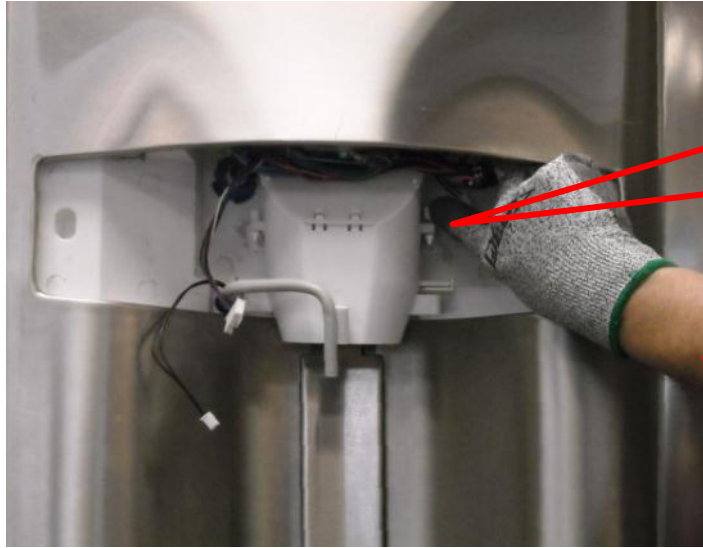

Push up on both the right and left retainers to release the funnel

Slide the funnel forward to remove

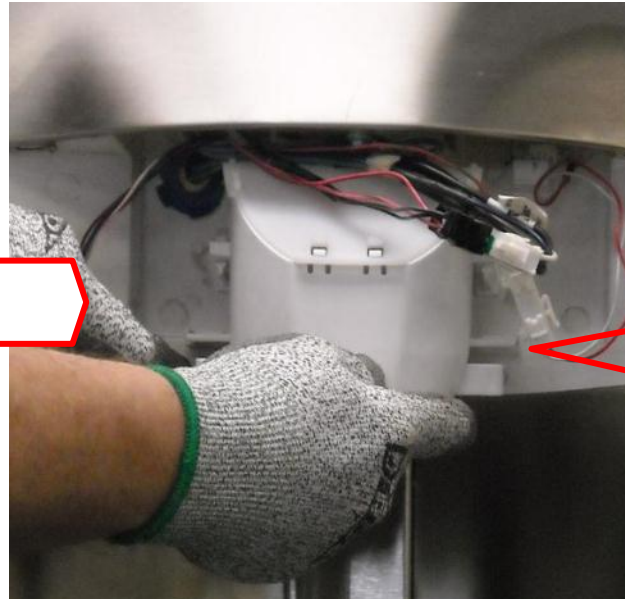

# Duct Door and Duct Door Motor Removal



- The motor opens and closes the duct door.
- The spring is used to keep the duct door closed.
- Take note of how the spring is installed before disassembly.

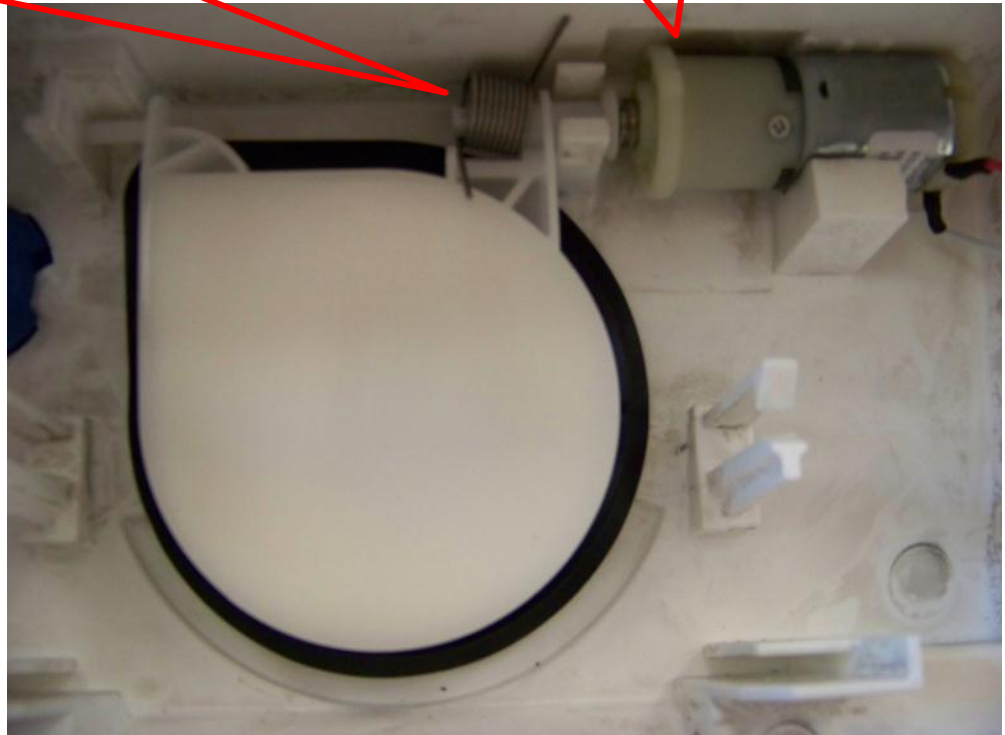



# Duct Door and Duct Door Motor Removal

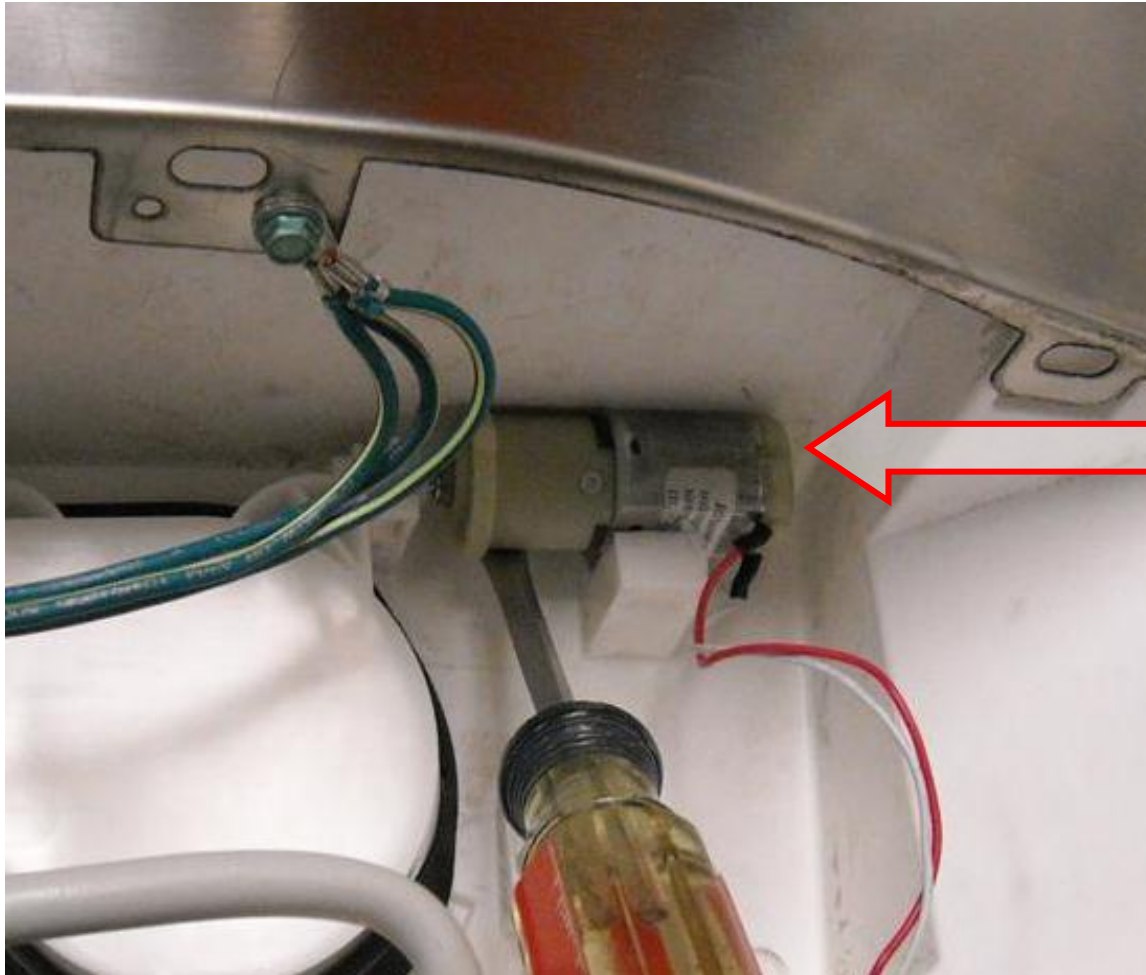

Gently pry the motor forward to release

# Duct Door and Duct Door Motor Removal

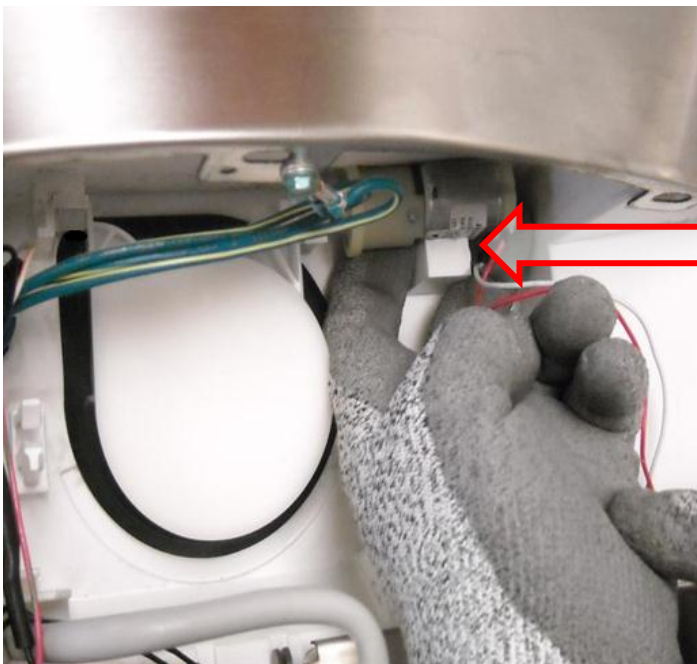

Pull the motor out of the bracket

Move the motor and duct door to the right to release the spring and pin

NOTE: The duct door and motor are available separately



# Dispenser Actuator Paddle and Switch

## Dispenser Actuator Paddle & Switch



- The paddle switch is a 2 position switch with 3 wires. It has a common with a normally open and normally closed contact.
- Both the door board and user interface board (UI) look for a change of state of both contacts when the paddle is depressed before the selected function is activated.
- The door board monitors one of the contacts and the user interface board (UI) monitors the other contact.

# Dispenser Actuator Paddle and Switch

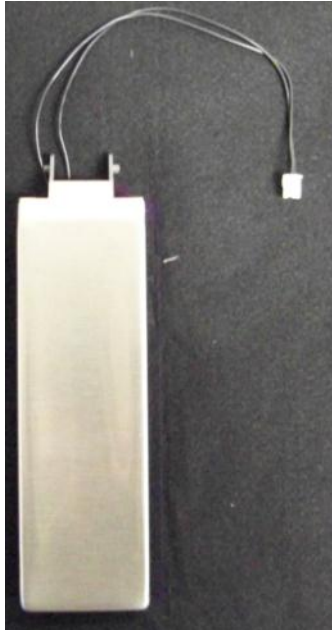

**Bottom Tabs**



# Dispenser Actuator Paddle and Switch

Flex either tab inward to disengage the pin from the hole in the tab. Then pull up to release the bottom tabs.

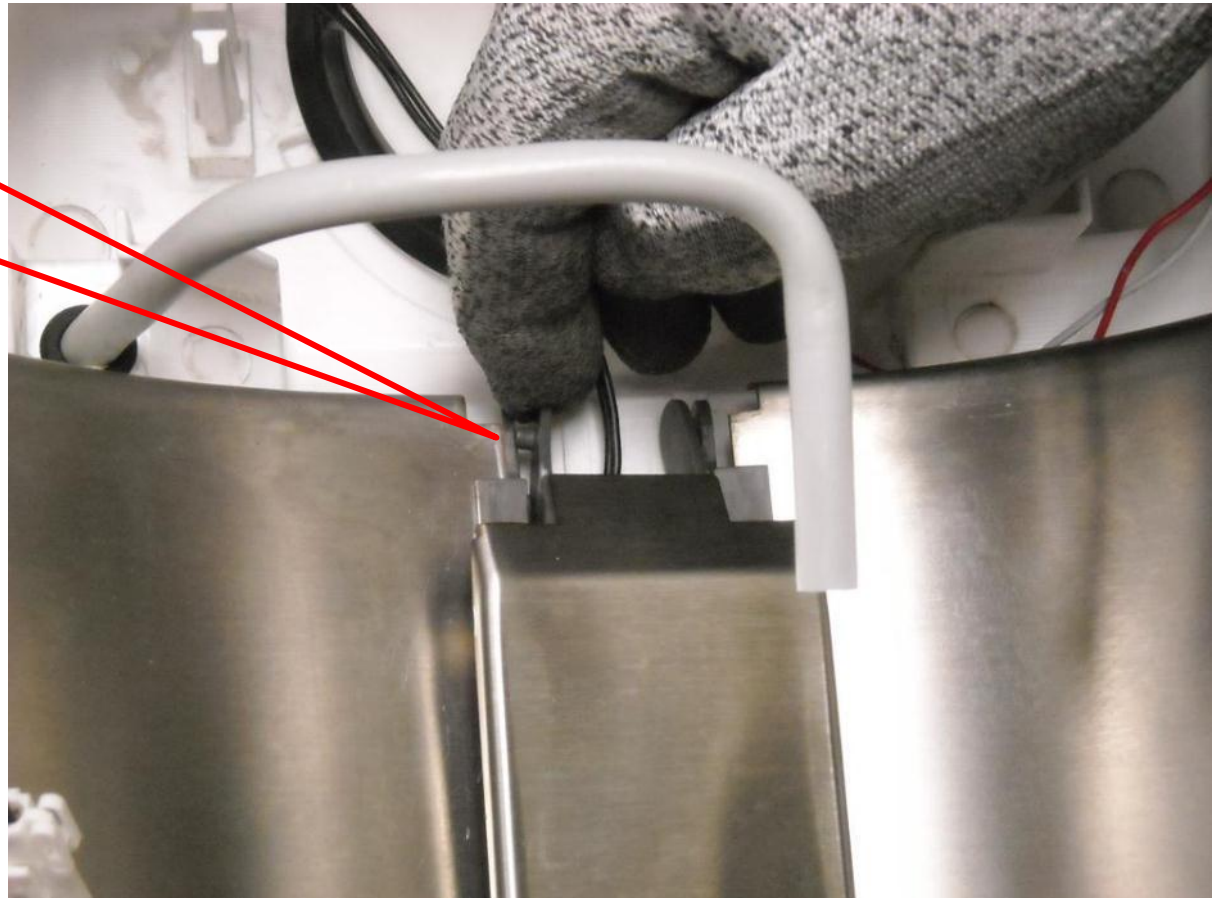

# Questions?