

GE Consumer & Industrial

Technical Service Guide

March 2008

Profile Bottom Freezer

PFSS6NKW
PFSF6NKW

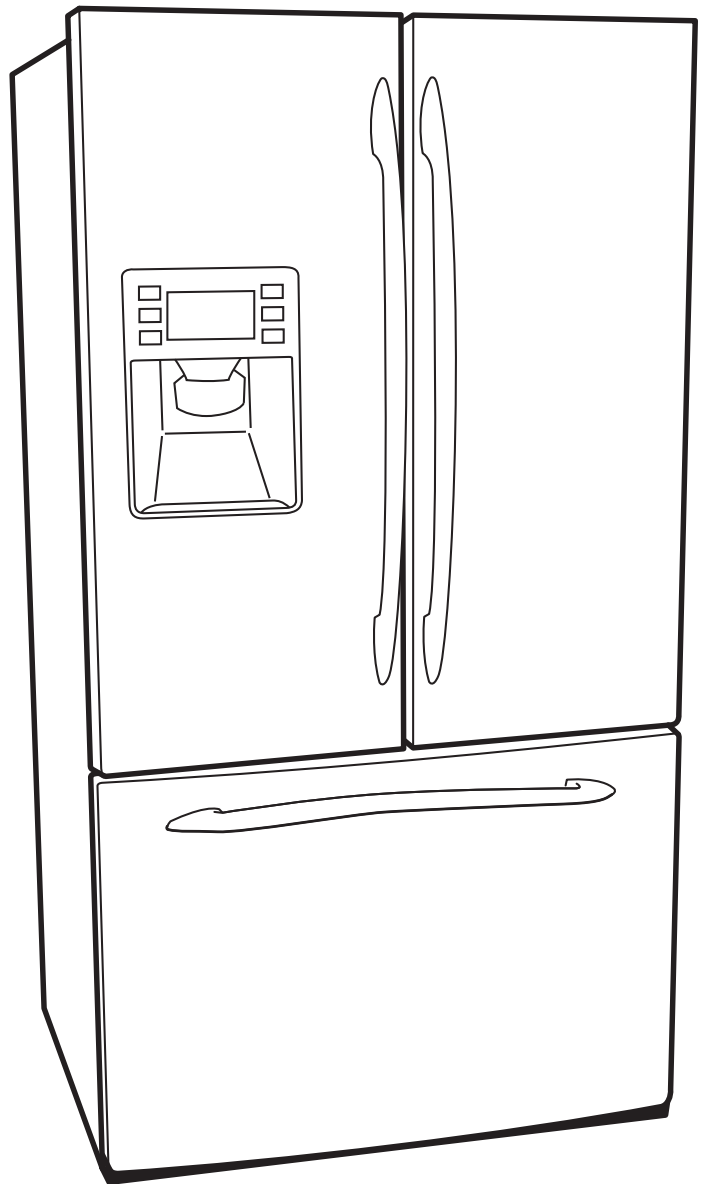

31-9162



GE Appliances
General Electric Company
Louisville, Kentucky 40225



IMPORTANT SAFETY NOTICE

The information in this service guide is intended for use by individuals possessing adequate backgrounds of electrical, electronic, and mechanical experience. Any attempt to repair a major appliance may result in personal injury and property damage. The manufacturer or seller cannot be responsible for the interpretation of this information, nor can it assume any liability in connection with its use.

WARNING

To avoid personal injury, disconnect power before servicing this product. If electrical power is required for diagnosis or test purposes, disconnect the power immediately after performing the necessary checks.

RECONNECT ALL GROUNDING DEVICES

If grounding wires, screws, straps, clips, nuts, or washers used to complete a path to ground are removed for service, they must be returned to their original position and properly fastened.

GE Consumer & Industrial
Technical Service Guide
Copyright © 2008

All rights reserved. This service guide may not be reproduced in whole or in part in any form without written permission from the General Electric Company.

Table of Contents

Articulating Door Mullion	62
Auger Motor Assembly.....	61
Circuit Boards	65
Components.....	29
Components Locator Views.....	25
Compressor	52
Condenser Fan.....	43
Control Board Connector Locator.....	27
Control Features.....	19
Control Panel Operation	67
Damper Assembly	56
Defrost Cycle.....	24
Defrost Heaters	49
Dispenser Assembly	54
Dispenser Display Assembly.....	53
Dispenser Heater	55
Dispenser Lock.....	24
Door Gaskets.....	34
Duct Heater	50
EMI Filter and Power Cord.....	51
Evacuation and Charging Procedure	9
Freezer Basket and Drawer.....	32
Freezer Door Handle	13
Freezer Evaporator	39
Freezer Evaporator Cover	37
Freezer Fan	40
Fresh Food Crispers and Pans	31
Fresh Food Door Handle	12
Fresh Food Evaporator	37
Fresh Food Evaporator Cover	35
Fresh Food Fan	42
Fresh Food Shelves and Bins.....	29

Ice Bucket and Icemaker	59
Ice Room Blower	41
Installation	11
Interior Airflow.....	10
Interior Lights.....	34
Introduction.....	5
Light Time-Out Function.....	24
Machine Compartment Cover	43
Nomenclature.....	6
Over Temperature Thermostats	48
Pantry Drawer Assembly	55
Pantry Drawer Control	56
PTCR Relay, Run Capacitor, and Overload Assembly.....	52
Refrigeration Components	8
Refrigeration System	8
Removing the Freezer Door	15
Removing the Refrigerator Door	13
Replacing Evaporators Using the LOKRING Method	40
Schematic.....	87
Technical Data.....	7
Test Mode Operation	71
Thermistors	45
Top Table.....	33
Troubleshooting.....	71
Vegetable and Fruit Drawers Shelf	55
Warranty	88
Water Tank	57

Introduction

The new Profile Bottom Mount Refrigerators have the following features:

- Available in 26-cubic foot capacity with fresh food french door configuration.
- ENERGY STAR® qualified.
- Integrated Dispenser with Crushed Ice, Water, and Actual Temperature Display — Features easy-to-reach, easy-to-read temperature controls and a setting to quickly restore proper temperature after frequent door openings.
- An articulating door mullion attached to the left-side door provides a movable center mullion that maximizes access to the fresh food compartment.
- Secure-Close Door Systems — Securely pulls the doors and drawers shut, even after you release the handles.
- ClimateKeeper™ with Dual Evaporators — Uses two evaporators to maintain higher humidity for fresh foods.
- Freshness Center™ — Offers maximum convenience by utilizing two humidity-controlled drawers and 1 full-length adjustable temperature deli drawer.
- An external "air" thermistor changes the control setting based on ambient condition to keep the fresh food and freezer at the correct temperature.
- TurboCool™ — Rapidly cools the refrigerator compartment in order to more quickly cool foods.
- TurboFreeze — Rapidly cools the freezer compartment in order to more quickly freeze foods.
- LED Lighting — Casts a clean, beautiful light throughout the fresh food area of the refrigerator. (GE Reveal™ Lighting in freezer.)
- Available in white or black finish or stainless wrap.



Note: Features may vary by model.

Nomenclature

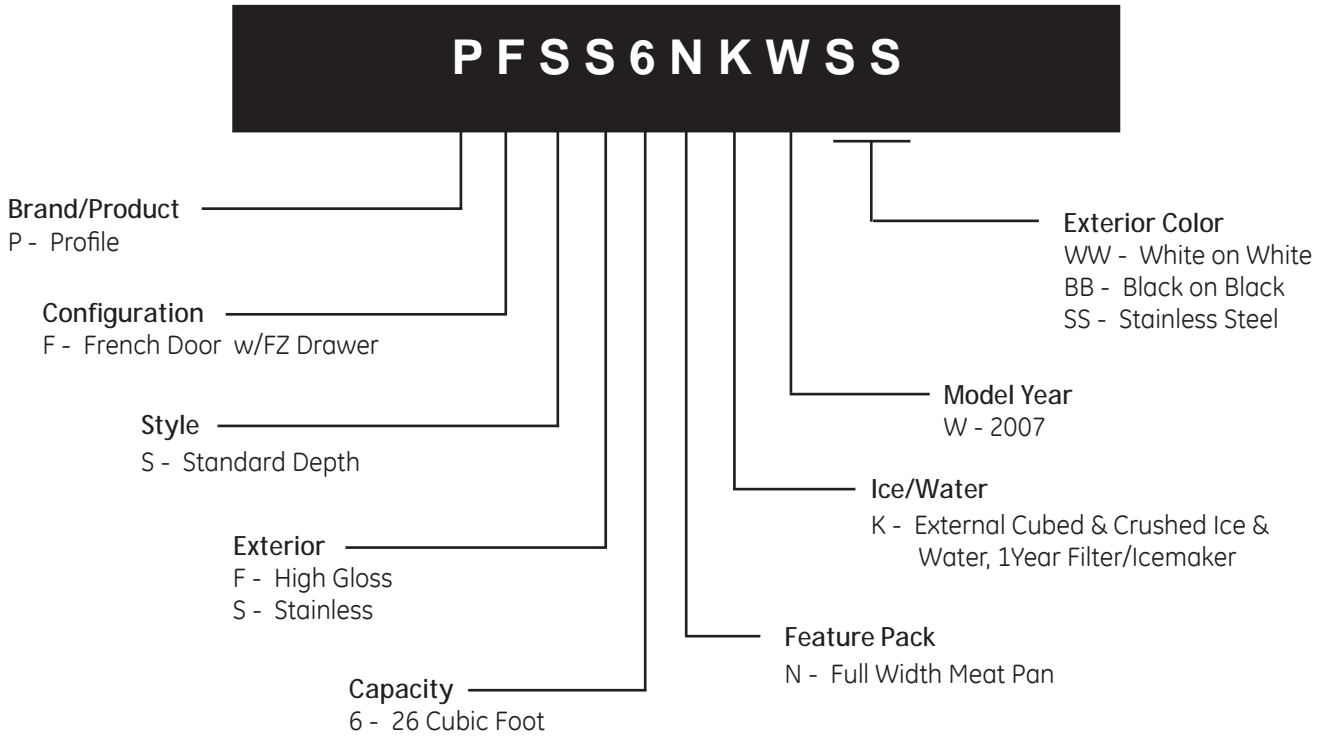

The nomenclature tag is located on the left wall of the fresh food compartment. It contains the following information:



- Model and Serial Number
- Minimum Installation Clearances
- Electrical Voltage, Frequency
- Maximum Amperage Rating
- Refrigerant Charge and Type

Serial Number

The first two numbers of the serial number identify the month and year of manufacture.

Example: **AR123456S** = January, 2008

A - JAN	2008 - R
D - FEB	2007 - M
F - MAR	2006 - L
G - APR	2005 - H
H - MAY	2004 - G
L - JUN	2003 - F
M - JUL	2002 - D
R - AUG	2001 - A
S - SEP	2000 - Z
T - OCT	1999 - V
V - NOV	1998 - T
Z - DEC	1997 - S

The letter designating the year repeats every 12 years.

Example:

T - 1974
T - 1986
T - 1998

Technical Data

DISCONNECT POWER CORD BEFORE SERVICING

IMPORTANT - RECONNECT ALL GROUNDING DEVICES

All parts of this appliance capable of conducting electrical current are grounded. If grounding wires, screws, straps, clips, nuts or washers used to complete a path to ground are removed for service, they must be returned to their original position and properly fastened.

IMPORTANT SAFETY NOTICE

This information is intended for use by individuals possessing adequate backgrounds of electrical, electronic and mechanical experience. Any attempt to repair a major appliance may result in personal injury and property damage. The manufacturer or seller cannot be responsible for the interpretation of this information, nor can it assume any liability in connection with its use.

ELECTRICAL SPECIFICATIONS

Temperature Control (Position 5)16(-11)°F
Defrost Control (w/no door openings)16hrs
Thermistor kilo-ohm resistance-2°F.....30.6kΩ
38°F.....11.6kΩ
77°F.....5.0kΩ
Overtemperature Thermostat140-104°F
Defrost Thermistor50°F
Electrical Rating: 115V AC 60 Hz5.2 A
Maximum Current Leakage0.75 mA
Maximum Ground Path Resistance0.14 Ω

NO LOAD PERFORMANCE

Control Position 5/5 and Ambient of 70°F to 90°F

Fresh Food, °F33 to 42°F
Frozen Food, °F-7 to 3°F
Run Time, % @ 70°F25 to 45
Run Time, % @ 90°F45 to 75

REFRIGERATION SYSTEM

Compressor 26 Model897BTU/hr
Minimum Equalized Pressure	
@ 90°F60 to 65 PSIG
@ 110°F75 to 82 PSIG

REFRIGERANT CHARGE (R134a)

26 Model5.643 ounces
----------	-------------------

Refrigeration System

Refrigeration Components

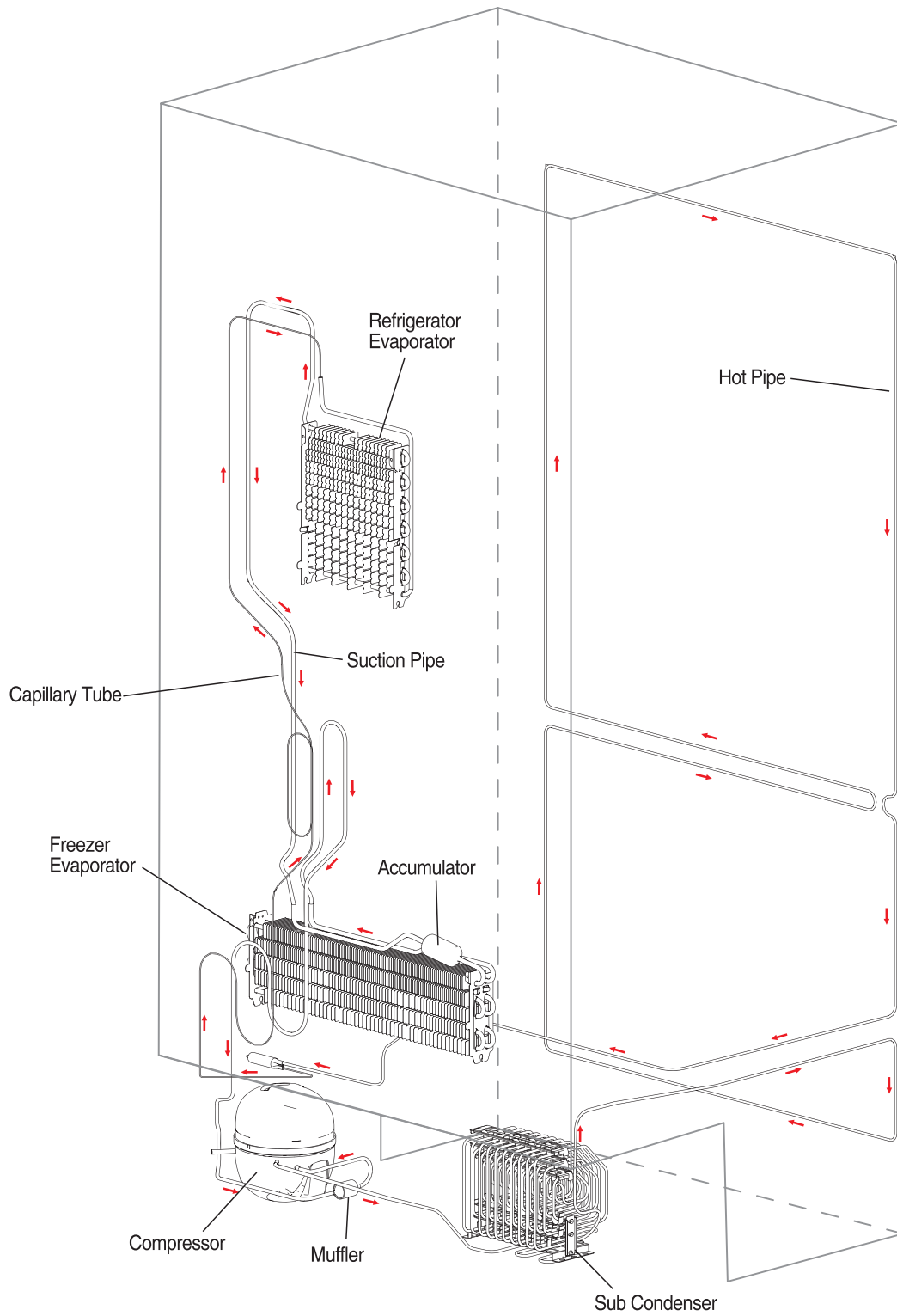

Evacuation and Charging Procedure

WARNING:

- Before cutting or using a torch on refrigerant tubes, recover the refrigerant from the system using approved recovery equipment.
 - Never charge new refrigerant through the purge valve. This valve is always located on the high pressure side of the system.
 - Never apply heat from any source to a container of refrigerant. Such action will cause excessive pressure in the container.
 - Always wear goggles when working with refrigerants and nitrogen holding charge in some replacement parts. Contact with these gases may cause injury.
1. Attach the hose from the R-134a charging cylinder to the process tube port on the compressor.
 2. Evacuate the system to a minimum 20-in. vacuum using the refrigerator compressor and recovery pump, which is attached to the new drier assembly.
 3. Turn off the recovery pump. Close the ball valve on the hose connected to the high-side port connection. Add 3 ounces of R-134a refrigerant to the system. Let the refrigerator operate and circulate the refrigerant for 5 minutes.
 4. Open the ball valve. Recover the purge/sweep charge using the recovery pump and the refrigerator compressor until a 20-in. vacuum is attained. Close the ball valve and remove the recovery hose.
 5. Charge the system with the exact amount of R-134a refrigerant specified.
 6. Disconnect the power cord to the refrigerator. This allows the pressure to equalize. After 3 to 5 minutes, the low side pressure will be positive and then the hose-to-charging port can be disconnected.
 7. Using an electronic leak detector, check all brazed joints and both schrader ports. Reinstall caps to schrader.

Interior Airflow

Air Flow (side view)

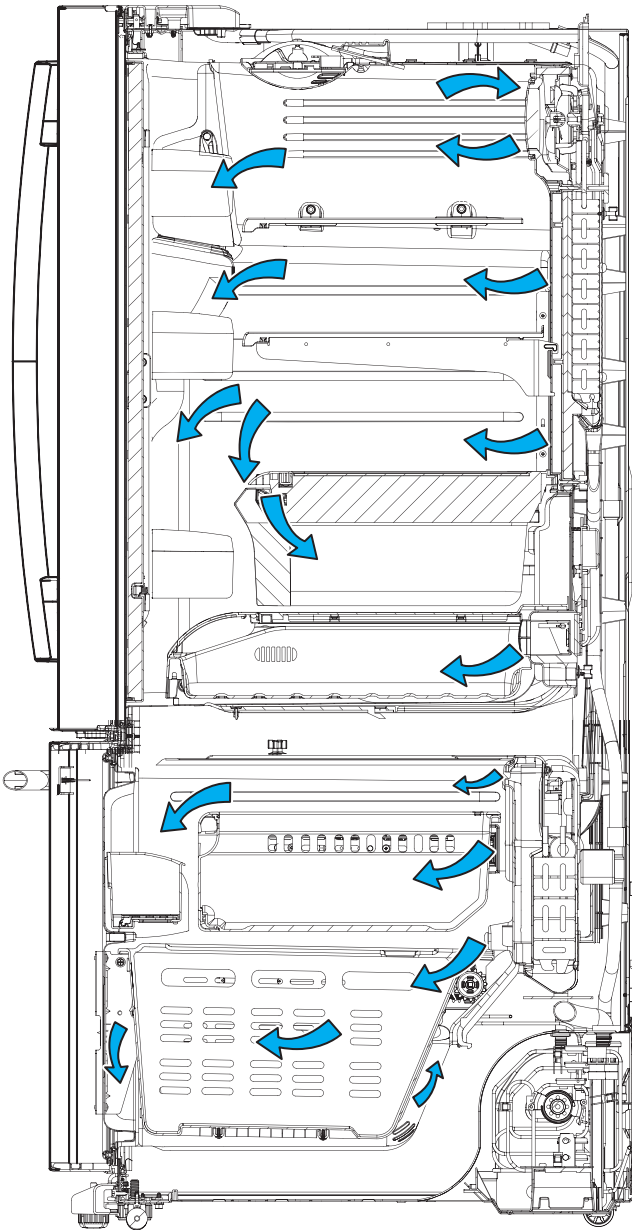

Air Flow (front view)

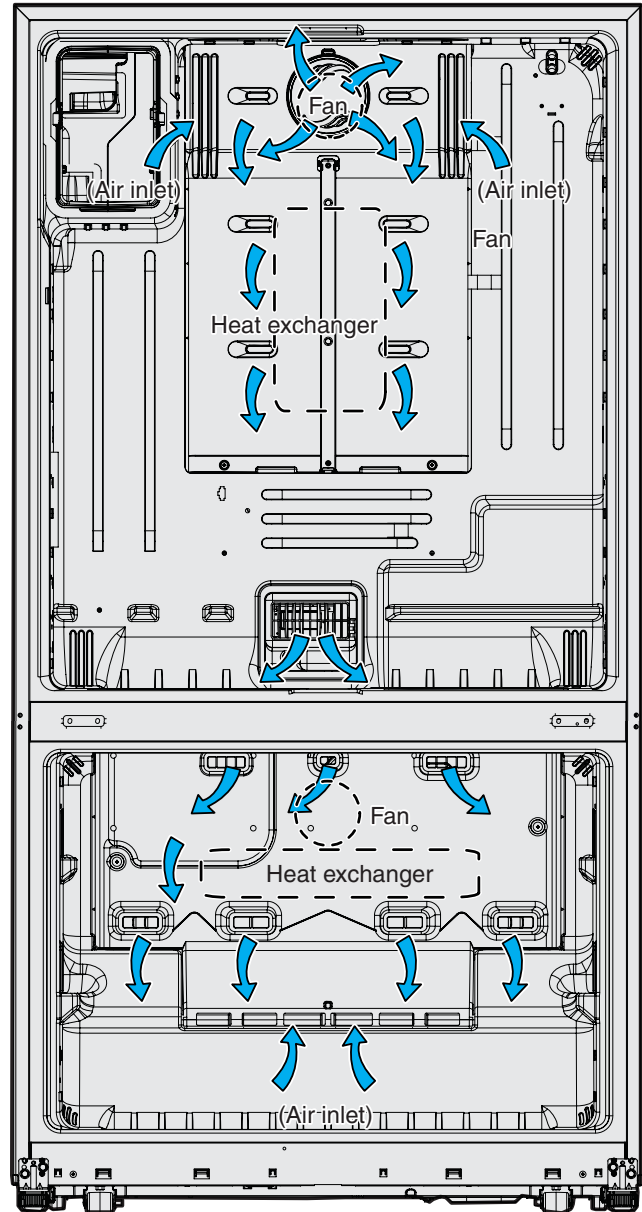

The fresh food evaporator fan forces air through the evaporator into the fresh food compartment. Air from the evaporator can also pass through the pantry room damper/heater assembly to the deli drawer, through the fresh food compartment, and return to the evaporator. The damper/heater assembly is controlled by the main control board. When open, the damper allows the chilled air from the fresh food evaporator to move into the deli drawer. Air returns from the fresh food compartment to the fresh food evaporator via two return vents located on the top left and right sides of the evaporator cover.

The freezer evaporator fan forces air through the evaporator into the freezer compartment. An additional ice room fan circulates air into and returns air from the ice room via plastic conduits embedded in the cabinet foam insulation. Air returns from the freezer compartment to the freezer evaporator via two return vents located on the bottom of the evaporator cover.

Installation

POWER CORD

The power cord of this appliance is equipped with a 3-prong (grounding) plug, which mates with a standard 3-prong (grounding) wall outlet to minimize the possibility of electric shock hazard from this appliance.

Have the wall outlet and circuit checked by a qualified electrician to make sure the outlet is properly grounded.

If the outlet is a standard 2-prong outlet, it is your personal responsibility and obligation to have it replaced with a properly grounded 3-prong wall outlet.

WARNING: Do not, under any circumstances, cut or remove the third (ground) prong from the power cord. For personal safety, this appliance must be properly grounded.

The refrigerator should always be plugged into its own individual electrical outlet, which has a voltage rating that matches the rating plate.

USE OF EXTENSION CORDS

Because of potential safety hazards under certain conditions, we strongly recommend against the use of an extension cord.

However, if you must use an extension cord, it is absolutely necessary that it be a UL-listed (in the United States) or a CSA-listed (in Canada), 3-wire grounding type appliance extension cord having a grounding type plug and outlet, and that the electrical rating of the cord be 15 amperes (minimum) and 120 volts.

REFRIGERATOR LOCATION

- Do not install the refrigerator where the temperature will go below 60°F (16°C) because it will not run often enough to maintain proper temperatures.
- Do not install the refrigerator where the temperature will go above 100°F (37°C) because it will not perform properly.
- Install it on a floor strong enough to support it fully loaded.

CLEARANCES

Allow the following clearances for ease of installation, proper air circulation and plumbing and electrical connections.

Sides	1/8" (3 mm)
Top	1" (25 mm)
Back	1" (25 mm)

REMOVE THE FRESH FOOD DOOR HANDLE

Stainless steel:

- A REMOVING THE DOOR HANDLE:** Loosen the set screws with the 3/32" Allen wrench and remove the handle.

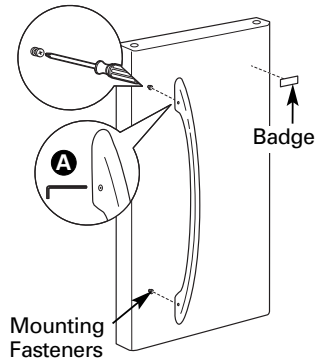

Plastic handle:

- A REMOVING THE DOOR HANDLE:** Slide the handle up and off of the mounting fasteners.

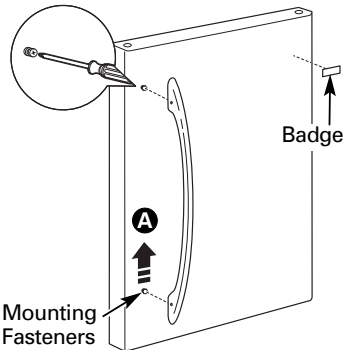

NOTE: If the handle mounting fasteners need to be tightened or removed, use a Phillips-head screwdriver.

ATTACH THE FRESH FOOD DOOR HANDLE

Stainless steel handle:

- A** Attach the handle to the handle mounting fasteners and tighten the set screws with a 3/32" Allen wrench.

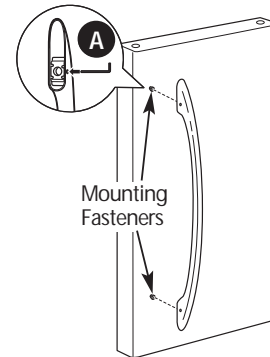

Plastic handle:

- A** Attach the handle to the handle mounting fasteners by aligning the slots with the handle mounting fasteners.
B Slide it down until it is firmly locked into position.

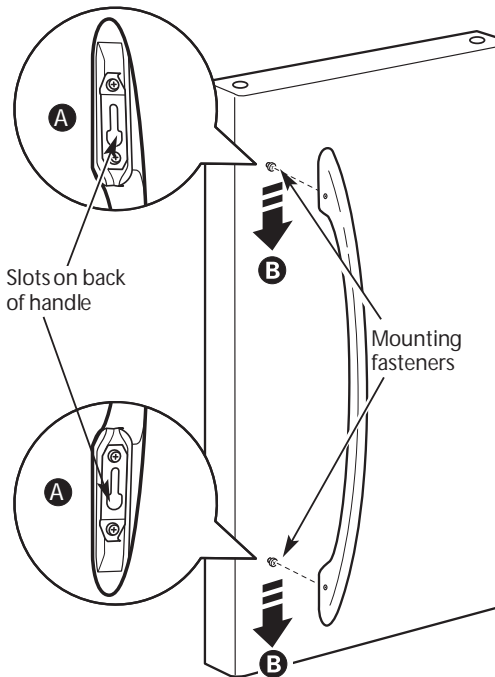

REMOVE THE FREEZER DOOR HANDLE

Stainless steel and plastic handles:

- A** Loosen the set screws located on the underside of the handle with the 1/8" Allen wrench and remove the handle.

NOTE: If the handle mounting fasteners need to be tightened or removed, use a Phillips-head screwdriver.

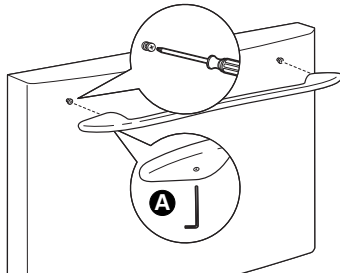

ATTACH THE FREEZER DOOR HANDLE

Stainless steel and plastic handles:

- A** Attach the handle firmly to the mounting fasteners and tighten the set screws on the bottom of the handle with a 1/8" Allen wrench.

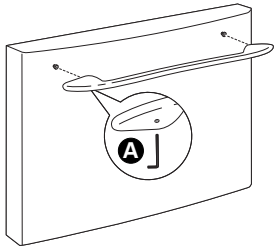

REMOVE THE REFRIGERATOR DOORS

- A** Open the refrigerator doors.
B Remove the two caps with a flat-head screwdriver.
C Remove the three screws on top with a Phillips-head screwdriver.

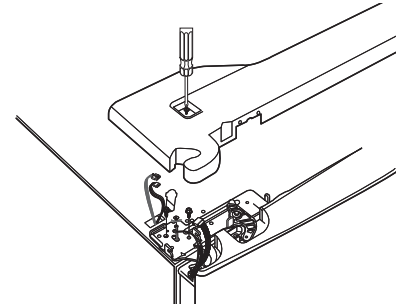

- D** Disengage the two electrical connectors.

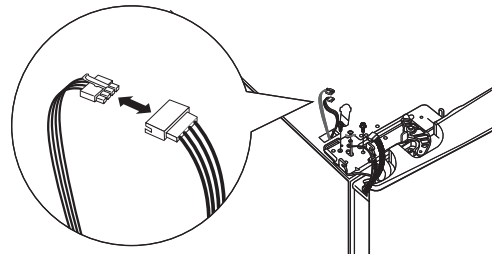

- E** To disconnect the water coupling, push in on the gray color of the coupling and pull out the tubing.

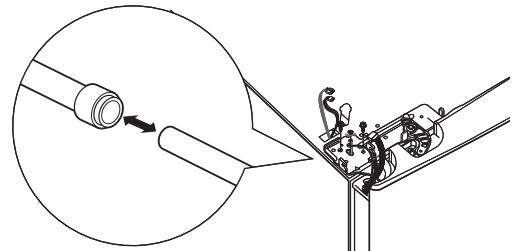

- F** Remove the two grounding cables with a Phillips-head screwdriver.

- G** Remove three 10 mm hex-head bolts (right and left).

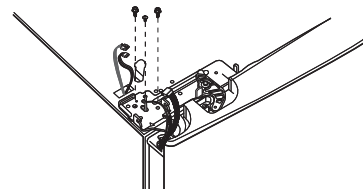

CAUTION: When the bolts are removed, the door may fall and cause personal injury and/or damage to the door itself.

REMOVE THE REFRIGERATOR DOORS (cont.)

H Lift the door straight up to remove.

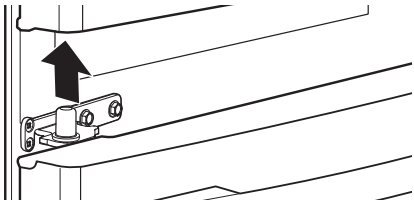

I Remove the two hex-head bolts and two Phillips-head screws from the center hinge. Set the hinge, bolts and screw aside.

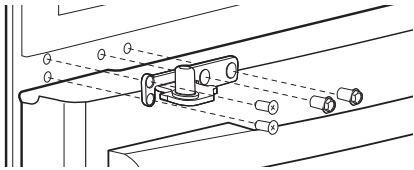

REPLACING THE REFRIGERATOR DOORS

A Install the center hinge on each side.

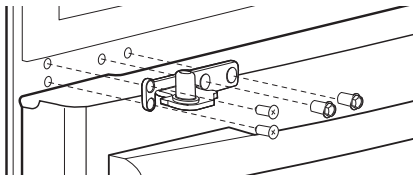

B Lower the refrigerator door onto the center hinge pin. Ensure that the plastic hinge pin thimble is on the center hinge pin or inside door hinge pin hole located in the bottom of the door.

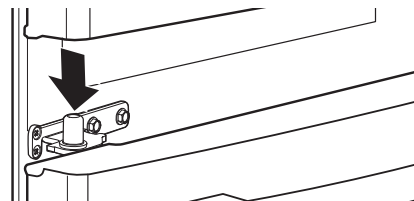

C Securely tape the door shut with masking tape or have a second person support the door.

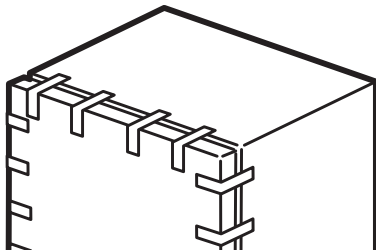

REPLACING THE REFRIGERATOR DOORS (cont.)

D Insert the top hinge pin into the hinge hole on top of the refrigerator door. Make sure the door is aligned with the cabinet and opposite door. Attach the hinge to the top of the cabinet. Do not tighten bolts completely.

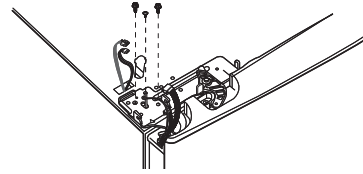

E On left-hand doors, pass the wires and water line through the top hinge pin. Then connect the water line and two connectors.

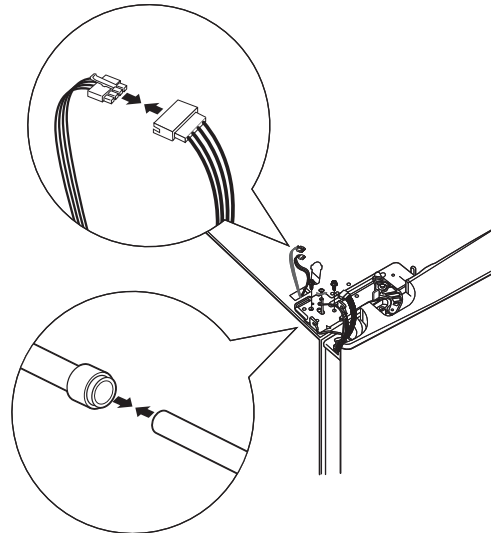

F Attach the ground wire with a Phillips-head screwdriver at the right and left hinge.

G Make sure the gasket on the door is flush against the cabinet and is not folded. Make sure the door is straight and the gap between the doors is even across the front. While holding the aligned door in place, tighten the top hinge bolts.

H Reconnect the two connectors at each side of the top cap and reattach the three Phillips-head screws on top.

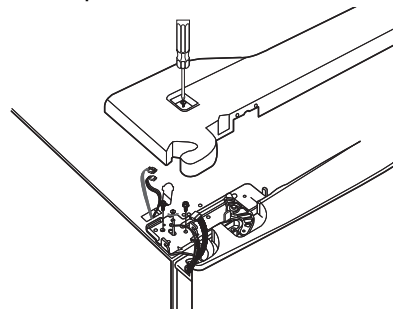

REMOVE THE FREEZER DOOR

- A** Pull the freezer door open to full extension.
- B** Remove the freezer bin by pulling both brackets upward at the same time.

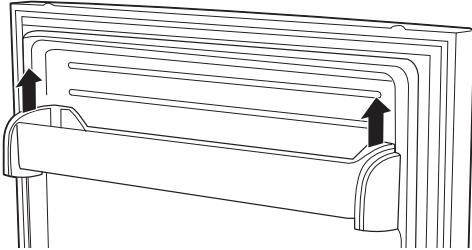

- C** Take out the lower basket by lifting the basket up from the rail system.

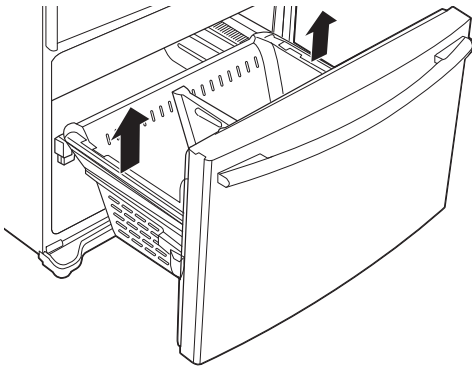

- D** Remove the two 10 mm hex-head bolts from the right and left side.

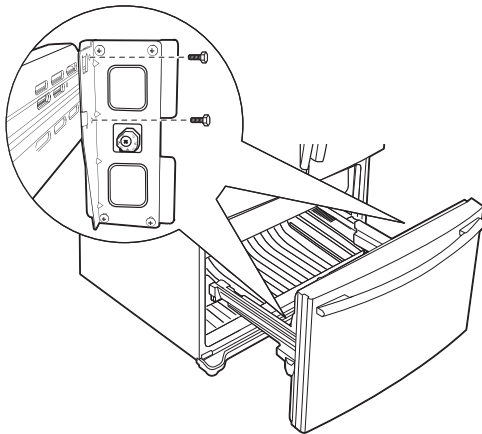

REMOVE THE FREEZER DOOR (cont.)

- E** Use the tip of a screwdriver to separate the rail from the rail cover. Tilt the front end up and lift the entire door.

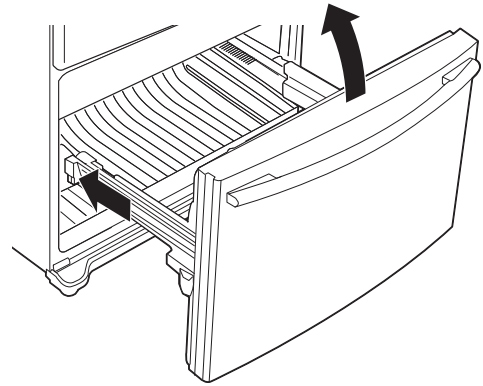

- F** Set the door front on a nonscratching surface.
- G** Push the rail assemblies back into the cabinet.

⚠ CAUTION: Push both sides of the rail assemblies back at the same time.

REPLACING THE FREEZER DOOR

Two people may be required to complete this procedure.

- 1 ATTACH AND SECURE THE DRAWER FRONT TO THE SLIDES**

- A** Pull out the rail assemblies to the full length on each side of the cabinet.

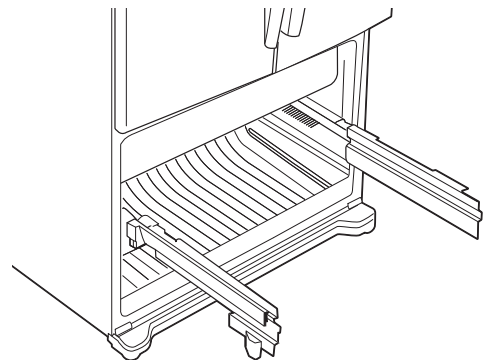

⚠ CAUTION: Make sure to pull out the side rails evenly.

REPLACING THE FREEZER DOOR (cont.)

- B** Hang the freezer door front onto open slots on the sides.

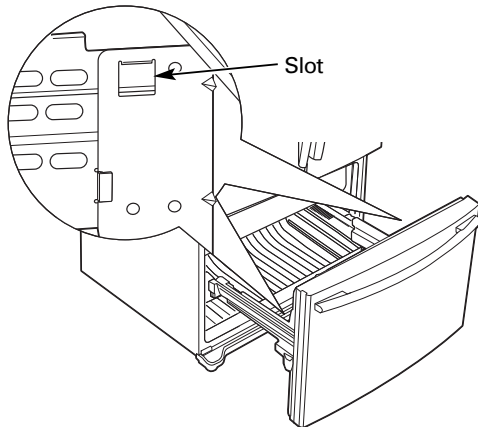

- C** Tighten screws completely. (There are four 10 mm hex-head bolts.)

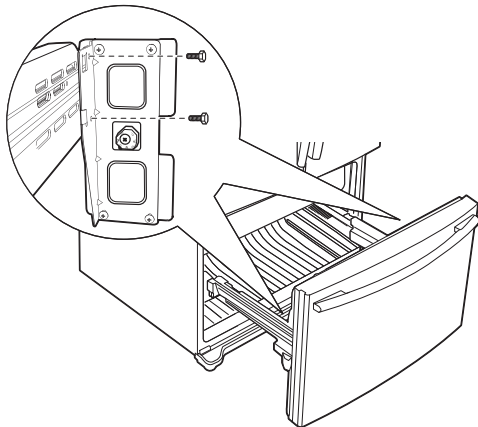

2 REPLACE THE FREEZER BASKET

Replace the freezer basket by lowering it into the frame.

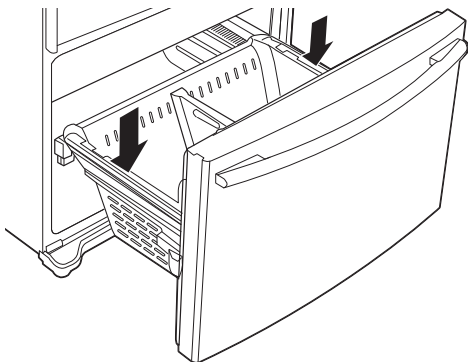

REPLACING THE FREEZER DOOR (cont.)

3 REPLACE THE FREEZER BIN

Hook the ends of the freezer bin into both brackets, and push down until they lock into place.

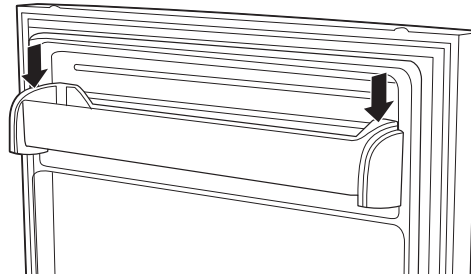

LEVEL THE REFRIGERATOR

The leveling legs have 2 purposes:

- 1) Leveling legs adjust so the refrigerator is firmly positioned on the floor and does not wobble.
- 2) Leveling legs serve as a stabilizing brake to hold the refrigerator securely in position during operation and cleaning. The leveling legs also prevent the refrigerator from tipping.

- A** Turn the leveling legs **clockwise to raise** the refrigerator, **counterclockwise to lower** it.

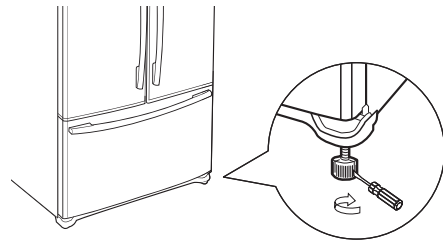

Flat-Head Screwdriver

⚠ CAUTION: To avoid possible personal injury or property damage, the leveling legs must be firmly touching the floor.

LEVEL THE REFRIGERATOR DOORS

Remember a level refrigerator is necessary for getting the doors perfectly even. If you need help, review the previous section on leveling the refrigerator.

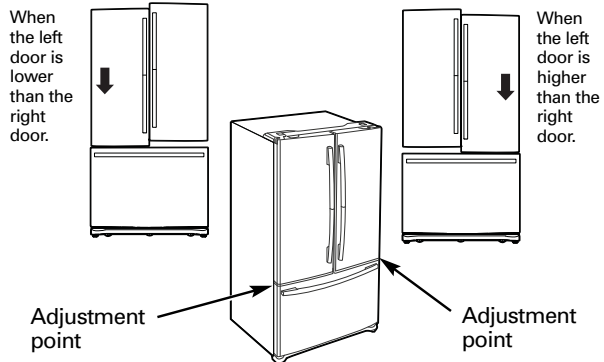

- A** If you open the freezer door, you can see the center hinge.
- B** Insert the supplied 4 mm Allen wrench into the shaft of the center hinge.

LEVEL THE REFRIGERATOR DOORS (cont.)

- C** Adjust the height by turning clockwise or counterclockwise. When you turn counterclockwise, the door will move up.

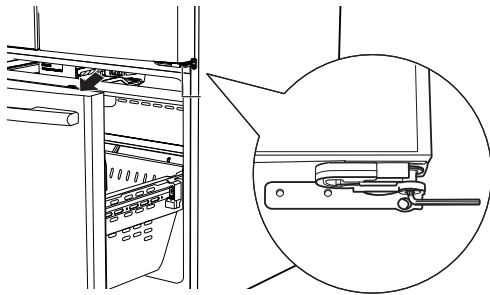

- D** After adjusting the doors, please insert the supplied fastener ring using a pair of pliers in the gap between the hinge grommet and the center hinge. The number of fastener rings you will need to insert depends on the gap.

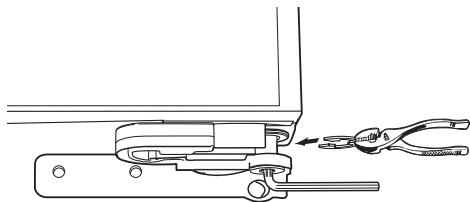

NOTE: Four fastener rings are enclosed with the refrigerator. Thickness of each fastener ring is 0.04".

LEVEL THE FREEZER DOOR

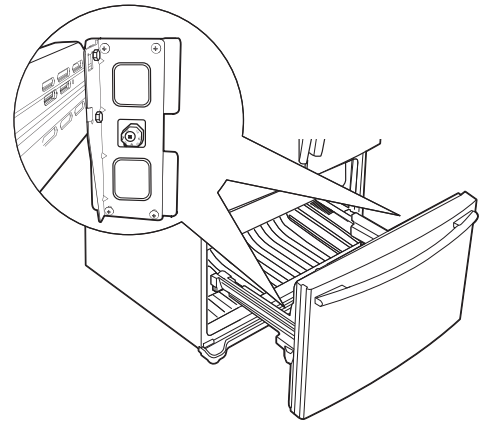

- A** Locate the height adjuster in the freezer door. Slightly loosen the four Phillips-head screws from the door on each side (right and left).

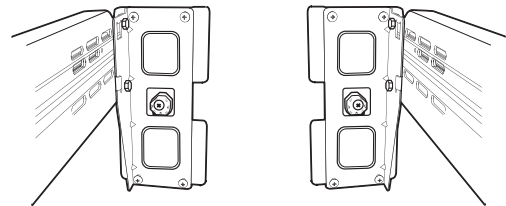

- B** Loosen the controller screw with a Phillips-head screwdriver to adjust the level.

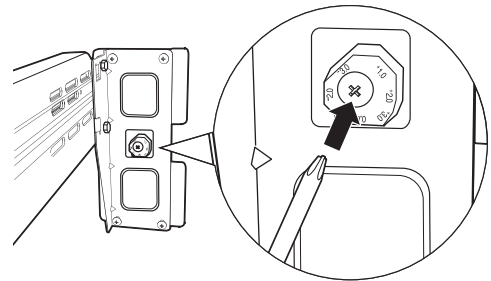

LEVEL THE FREEZER DOOR (cont.)

- C** Find the best position to align the door slope.

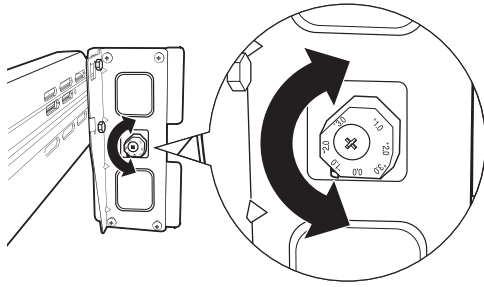

Example: The slope is about 2 mm as shown below.

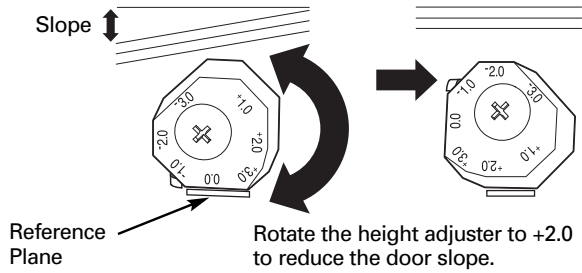

- D** After adjustment, tighten all the screws.

Control Features

About the controls with temperature settings.

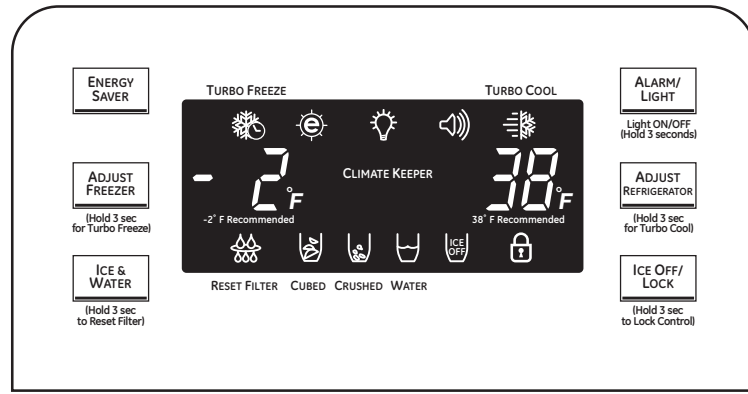

NOTE: The refrigerator is shipped with protective film covering the temperature controls. If this film was not removed during installation, remove it now.

The temperature controls are preset in the factory at **38°F** for the refrigerator compartment and **-2°F** for the freezer compartment. Allow 24 hours for the temperature to stabilize to the preset recommended settings.

The temperature controls can display both the **SET** temperature as well as the actual temperature in the refrigerator and freezer. The actual temperature may vary slightly from the **SET** temperature based on usage and operating environment.

Changing the Temperature

To change the temperature, press and release the **ADJUST FREEZER** or **ADJUST REFRIGERATOR** pad. The display will show the actual temperature. To change the temperature, tap either the **ADJUST FREEZER** or **ADJUST REFRIGERATOR** pad until the desired temperature is displayed.

Once the desired temperature has been set, the temperature display will return to the actual refrigerator and freezer temperatures after 10 seconds. Several adjustments may be required.

Each time you adjust controls, allow 24 hours for the refrigerator to reach the temperature you have set.

About TurboCool™ and TurboFreeze.™

ADJUST
REFRIGERATOR

(Hold 3 sec
for Turbo Cool)

How it Works

TurboCool rapidly cools the refrigerator compartment in order to more quickly cool foods. Use **TurboCool** when adding a large amount of food to the refrigerator compartment, putting away foods after they have been sitting out at room temperature or when putting away warm leftovers. It can also be used if the refrigerator has been without power for an extended period.

The compressor and fresh food fan will run immediately until the fresh food temperature cools to approximately 25°F (-4°C), maximum run time two-and-a-half hours. After reaching 25°F (-4°C), fresh food compartment will run at cold setting for one hour and return to the original setting value.

How to Use

Press and hold the **ADJUST REFRIGERATOR** pad for 3 seconds until you hear the sound and the  displays.

After **TurboCool** is complete, the refrigerator compartment will return to the original setting.

NOTES: The refrigerator temperature cannot be changed during **TurboCool**.

The freezer temperature is not affected during **TurboCool**.

ADJUST
FREEZER

(Hold 3 sec
for Turbo Freeze)

How it Works

TurboFreeze rapidly cools the freezer compartment in order to more quickly cool foods. Use **TurboFreeze** when adding a large amount of food to the freezer compartment, putting away foods after they have been sitting out at room temperature or when putting away warm leftovers. It can also be used if the refrigerator has been without power for an extended period.

The compressor and fresh food fan will run immediately and keep running for two-and-a-half hours.

How to Use

Press and hold the **ADJUST FREEZER** pad for 3 seconds until you hear the sound and the  displays.

After **TurboFreeze** is complete, the freezer compartment will return to the original setting.

NOTES: The freezer temperature cannot be changed during **TurboFreeze**.

The refrigerator temperature is not affected during **TurboFreeze**.

When opening the freezer door during **TurboFreeze**, the fans will continue to run if they have cycled on.

ALARM/
LIGHT

Light ON/OFF
(Hold 3 seconds)

About Door Alarm

The door alarm will sound if any door is open for more than 3 minutes. The beeping stops when you close the door.

About Dispenser Light

Press and hold the **ALARM/LIGHT** pad for 3 seconds to **turn on** the dispenser light. To **turn off**, press and hold the pad again for 3 seconds.

ENERGY
SAVER

About Energy Saver

This product is equipped with an Energy Saver feature. The refrigerator is shipped with the Energy Saver feature on. Over time, moisture can form on the front surface of the door mullion and dispenser recess and can cause rust. If moisture does appear on the front surface of the door mullion and dispenser recess, turn off the Energy Saver feature by pressing and releasing the **ENERGY SAVER** pad on the control panel.

About the water filter.



Water Filter Cartridge

The water filter cartridge is located in the back upper right corner of the refrigerator compartment.

When to Replace the Filter

There is a replacement indicator light for the water filter cartridge on the temperature display. This light will turn orange to tell you that you need to replace the filter soon. The filter cartridge should be replaced when the replacement indicator light turns red or if the flow of water to the dispenser or icemaker decreases.

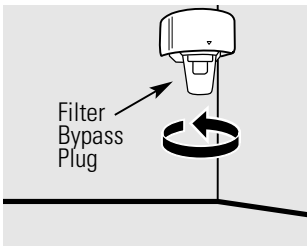
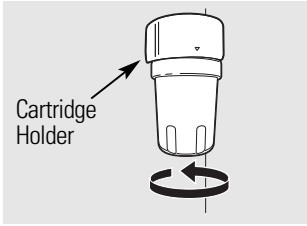

Installing the Filter Cartridge

- 1 If you are replacing the cartridge, first remove the old one by slowly turning it counterclockwise. A small amount of water may drip down.

CAUTION: If air has been trapped in the system, the filter cartridge may be ejected as it is removed. Use caution when removing.

- 2 Remove the protective foil from the end of the cartridge.
- 3 Lining up the arrow on the cartridge and the cartridge holder, place the top of the new cartridge up inside the holder. Do not push it up into the holder. Slowly rotate the cartridge clockwise until it stops. As you turn the cartridge, it will automatically raise itself into position. Cartridge will rotate about 1/4 turn. **Do not overtighten.**
- 4 Run water from the dispenser for 3 minutes (about 1½ gallons) to clear the system and prevent sputtering. See *To Use the Dispenser* section.
- 5 Press and hold the **ICE & WATER** pad for 3 seconds.

NOTE: A newly installed water filter cartridge may **cause water to spurt** from the dispenser.

Filter Bypass Plug

You must use the filter bypass plug when a replacement filter cartridge is not available. The icemaker will not operate without the filter or filter bypass plug.

Replacement Filters:

To order additional filter cartridges in the United States, visit our Website, ge.com, or call GE Parts and Accessories, 800.626.2002.

Filter Model MWF

Customers in Canada should consult the yellow pages for the nearest Mabe Service Center.



Replacing the light bulbs.

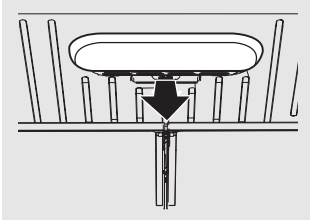

Refrigerator Lights

An authorized technician will need to replace the LED light.

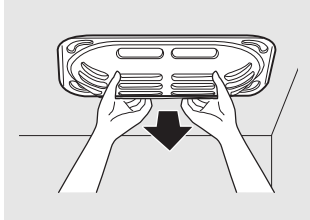

Freezer Light

⚠ CAUTION: *Light bulbs may be hot.*

- 1 Unplug the power cord from the outlet.
- 2 Pull drawer out to the stop position.
- 3 Rotate the shield down while pushing it backwards to remove it.

- 4 Turn the bulb counterclockwise.
- 5 Replace with an appliance bulb of the same or lower wattage.
- 6 Replace the shield.
- 7 Plug the refrigerator back in.

NOTE: *Appliance bulbs may be ordered from GE Parts and Accessories, 800.626.2002.*

About the automatic icemaker.

A newly installed refrigerator may take 12 to 24 hours to begin making ice.

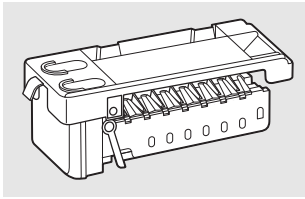

**ICE OFF/
LOCK**

(Hold 3 sec
to Lock Control)

Automatic Icemaker

The icemaker will produce seven cubes per cycle—approximately 100–130 cubes in a 24-hour period, depending on freezer compartment temperature, room temperature, number of door openings and other use conditions.

If the refrigerator is operated before the water connection is made to the icemaker, **turn on** the **ICE OFF** feature by pressing and releasing the **ICE OFF/LOCK** pad on the control panel and the  displays.

When the refrigerator has been connected to the water supply, **turn off** the **ICE OFF** feature by pressing and releasing the **ICE OFF/LOCK** pad on the control panel.

The icemaker will fill with water when it cools to 15°F (–10°C). A newly installed refrigerator may take 12 to 24 hours to begin making ice cubes.

You will hear a buzzing sound each time the icemaker fills with water.

Throw away the first few batches of ice to allow the water line to clear.

Be sure nothing interferes with the sweep of the feeler arm.

When the bin fills to the level of the feeler arm, the icemaker will stop producing ice. It is normal for several cubes to be joined together.

If ice is not used frequently, old ice cubes will become cloudy, taste stale and shrink.

NOTE: In homes with lower-than-average water pressure, you may hear the icemaker cycle multiple times when making one batch of ice.

NOTE: Turn on the **ICE OFF** feature if the water supply is shut off.

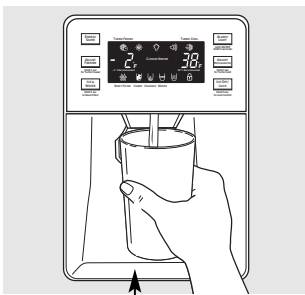

Spill Shelf

**ICE &
WATER**

To Use the Dispenser

Select **CUBED** , **CRUSHED**  or **WATER**  by pressing the **ICE & WATER** pad.

Press the glass gently against the top of the dispenser cradle.

The spill shelf is not self-draining. To reduce water spotting, the shelf should be cleaned regularly.

If no water is dispensed when the refrigerator is first installed, there may be air in the water line system. Press the dispenser arm for at least two minutes to remove trapped air from the water line and to fill the water system. To flush out impurities in the water line, throw away the first six full glasses of water.

⚠ CAUTION: Never put fingers or any other objects into the ice crusher discharge opening.

**ICE OFF/
LOCK**

(Hold 3 sec
to Lock Control)

To Lock and Unlock the Dispenser

To lock, press and hold the **ICE OFF/LOCK** pad for 3 seconds. Repeat this step to unlock the dispenser.

**ALARM/
LIGHT**

Light ON/OFF
(Hold 3 seconds)

Dispenser Light

Press and hold the **ALARM/LIGHT** pad for 3 seconds to turn the dispenser light on and off.

The light also comes on when the dispenser cradle is pressed.

Important Facts About Your Dispenser

- Do not add ice from trays or bags to the storage drawer. It may not crush or dispense well.
- Avoid overfilling glass with ice and use of narrow glasses. Backed-up ice can jam the chute or cause the door in the chute to freeze shut. If ice is blocking the chute, poke it through with a wooden spoon.
- Beverages and foods should not be quick-chilled in the ice storage drawer. Cans, bottles or food packages in the storage drawer may cause the icemaker or auger to jam.
- To keep dispensed ice from missing the glass, put the glass close to, but not touching, the dispenser opening.
- Some crushed ice may be dispensed even though you selected **CUBED ICE**. This happens occasionally when a few cubes accidentally get directed to the crusher.
- After crushed ice is dispensed, some water may drip from the chute.
- Sometimes a small mound of snow will form on the door in the ice chute. This condition is normal and usually occurs when you have dispensed crushed ice repeatedly. The snow will eventually evaporate.

Defrost Cycle

Fresh Food Defrost Cycle

The refrigerator evaporator utilizes an adaptive defrost cycle that operates a metal sheath heater to remove frost from the evaporator.

If the main board senses any door opening, the defrost cycle is every 12 hours. Otherwise, the defrost cycle is 16 hours.

The control board determines the length of time the heater is energized. It does this by monitoring the fresh food evaporator thermistor. Once the temperature of the thermistor reaches 54°F (12°C), the control cycles the defrost heater off. A bimetal safety thermostat provides a backup in the event the evaporator thermistor fails. The safety thermostat prevents the temperature from exceeding 140°F (60°C).

Freezer Defrost Cycle

The freezer evaporator utilizes an adaptive defrost cycle that operates a metal sheath heater to remove frost from the evaporator.

If the main board senses any door opening, the defrost cycle is every 12 hours. Otherwise, the defrost cycle is 16 hours.

The control board determines the length of time the heater is energized. It does this by monitoring the freezer evaporator thermistor. Once the temperature of the thermistor reaches 50°F (10°C), the control cycles the defrost heater off. A bimetal safety thermostat provides a backup in the event the evaporator thermistor fails. The safety thermostat prevents the temperature from exceeding 140°F (60°C).

Light Time-Out Function

The refrigerator incorporates a light time-out function for the fresh food and freezer sections. If either of the fresh food doors or the freezer drawer is left open for 10 minutes, the main control board will turn off the lights in that section. If the open door or drawer is closed, and then reopened, the timer in the main control board will reset for another 10 minute count.

Dispenser Lock

When the dispenser system is locked, actual and set temperatures can be viewed but no dispenser command will be accepted. This includes the dispenser cradle and will prevent accidental dispensing that may be caused by children or pets. If a pad or the cradle is depressed with the system locked, it will not be acknowledged.

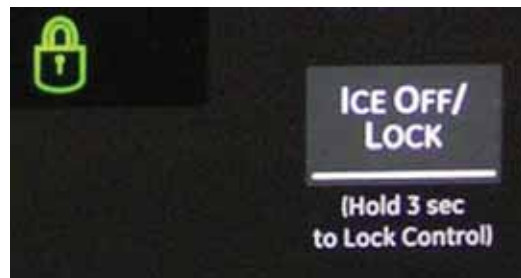

Components Locator Views

Fresh Food Compartment

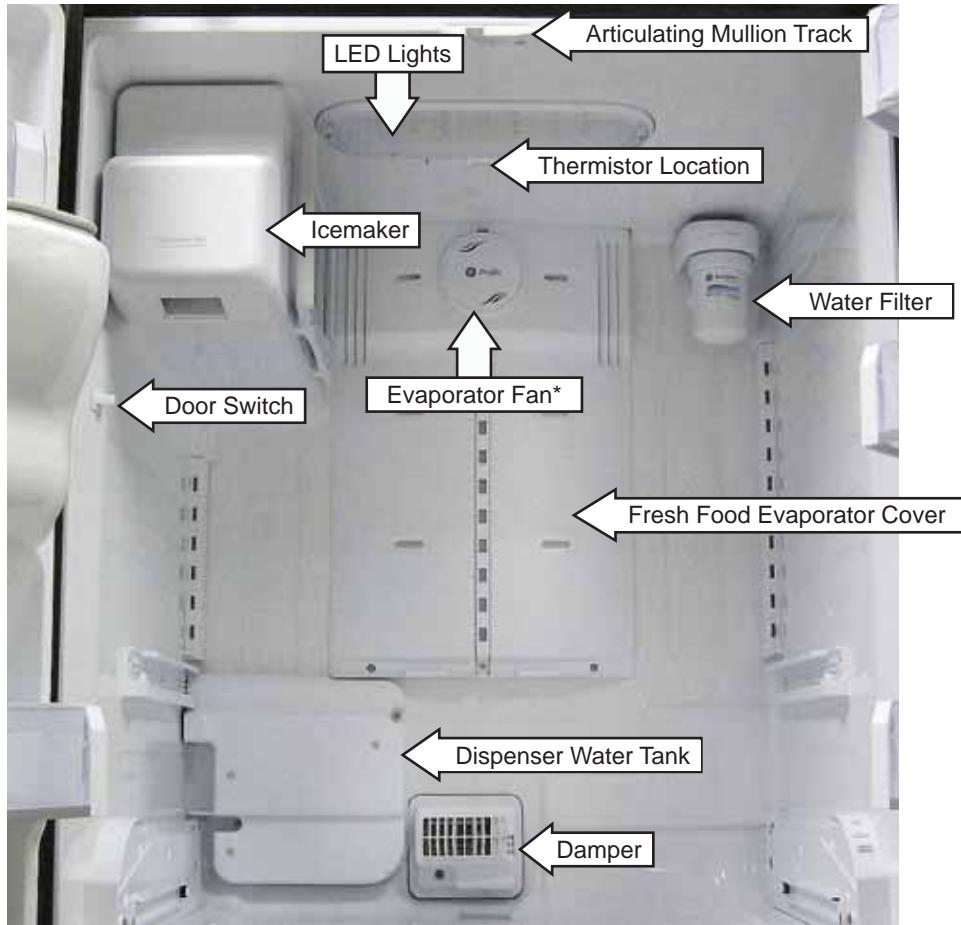

*The evaporator fan is attached to the inside of the cover.

Fresh Food Evaporator (shown with cover removed)

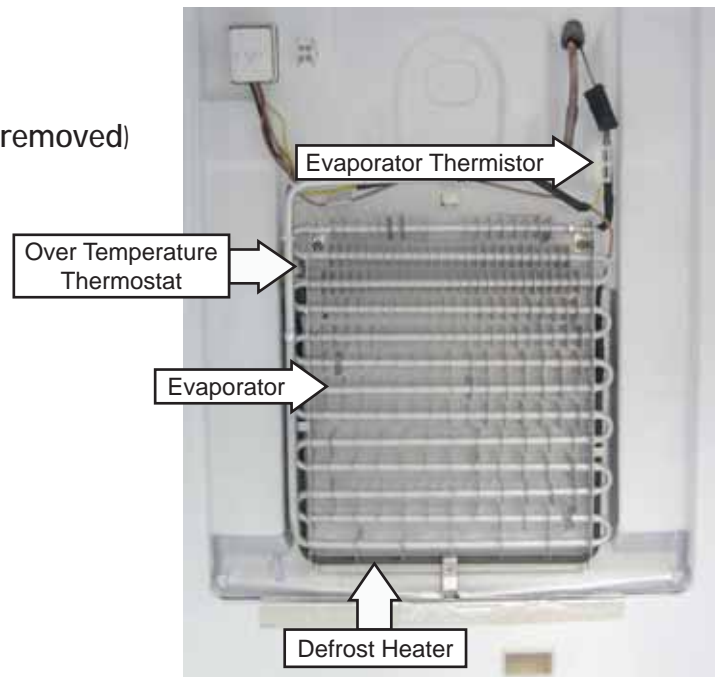

(Continued next page)

Freezer Compartment

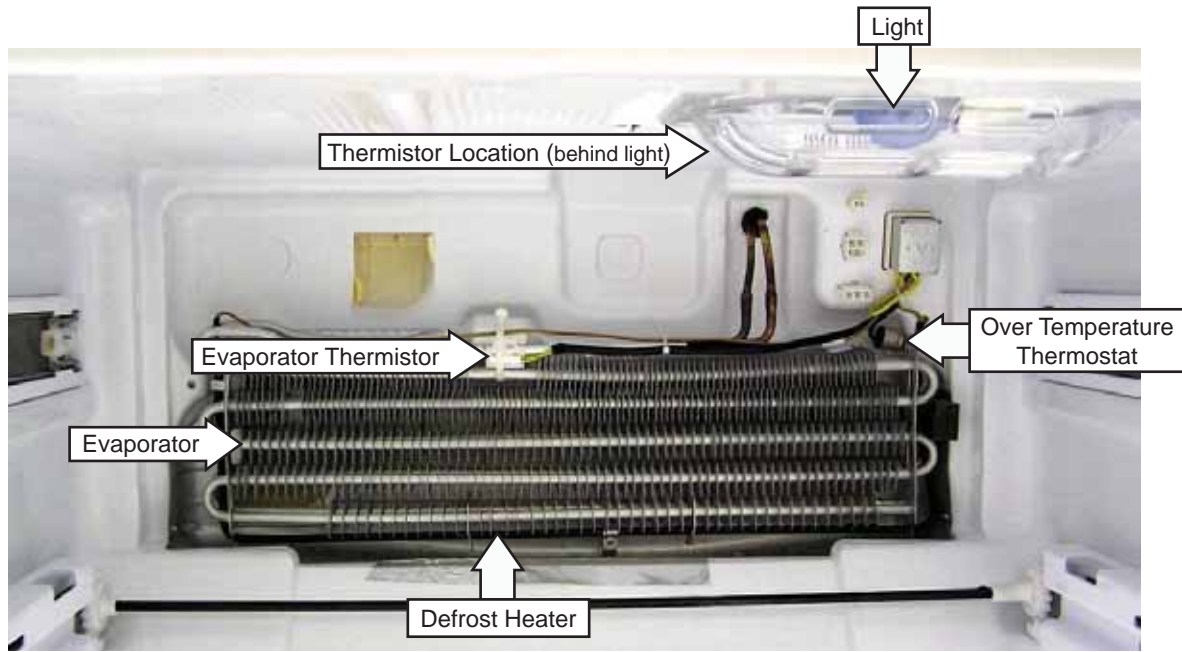

Note: The evaporator fan is attached to the inside of the evaporator cover (not shown).

Rear View

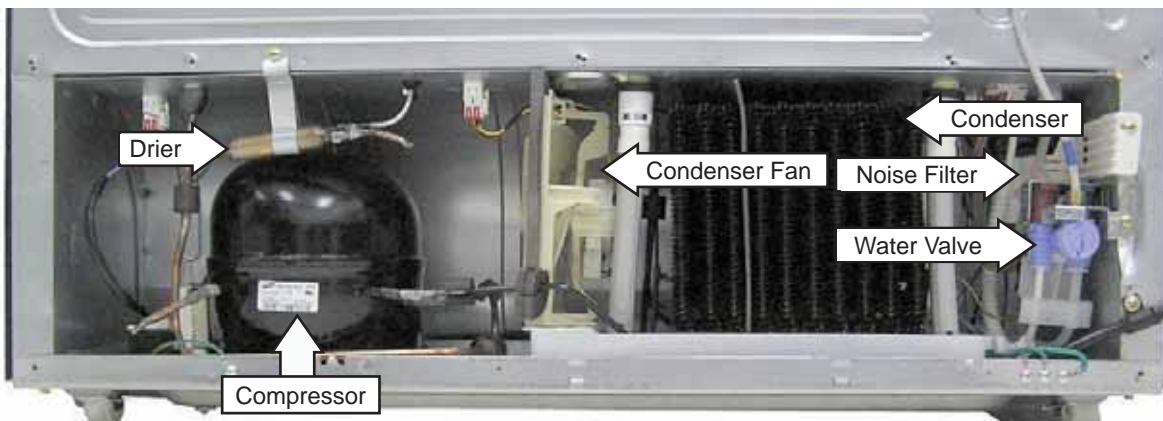
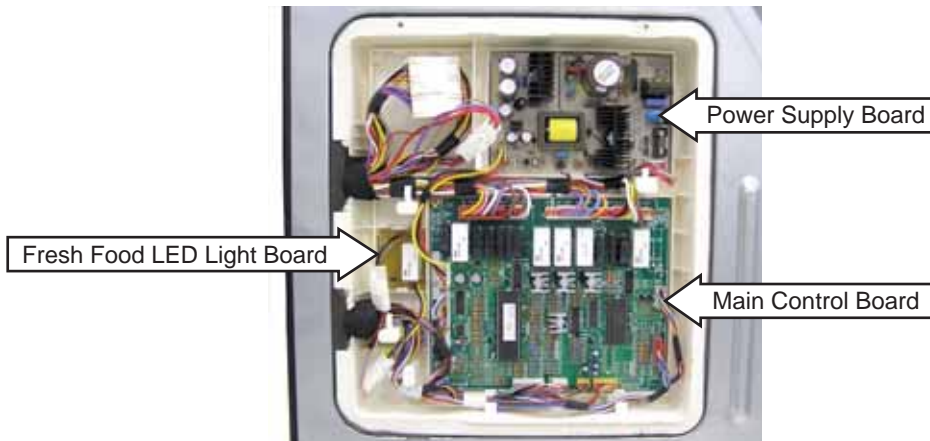

Control Board Connector Locator

Main Control Board

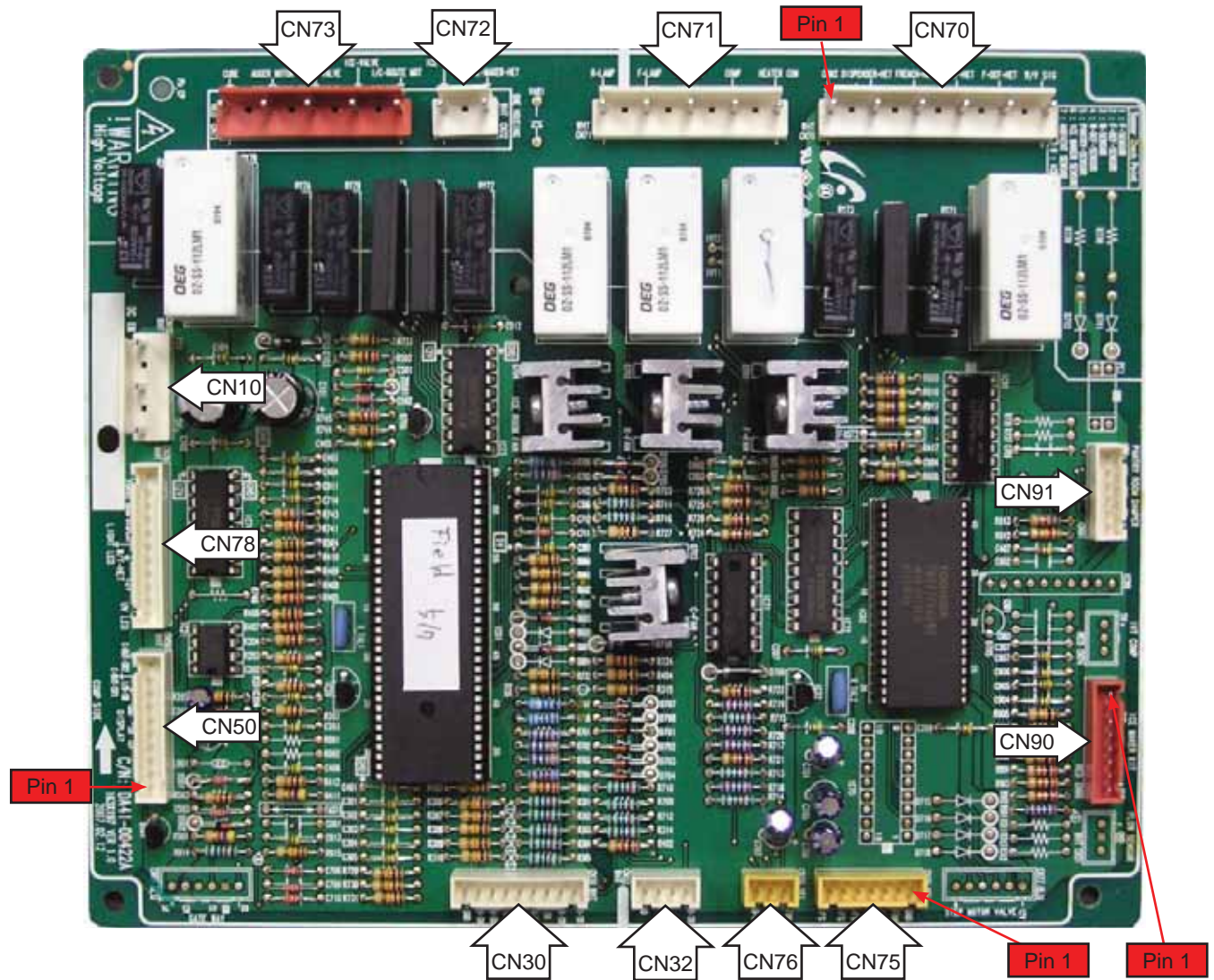

CN10 - Power Supply +5 VDC and +12 VDC Input

CN30 - FZ Door Switch, FF Left and Right Door Switches, FZ Sensor, FZ Defrost Sensor, FF Sensor, FF Defrost Sensor, Pantry Sensor

CN32 - Ambient Sensor, Ice Room Sensor

CN50 - Dispenser PBA Panel

CN70 - FZ Defrost Heater, FF Defrost Heater, Ice Pipe Heater, French Heater, Dispenser Heater

CN71 - Compressor, FZ Room Lamp

CN72 - Icemaker Heater, Icemaker G Motor

CN73 - Ice Cover Route G Motor, Icemaker Water Valve Solenoid, Dispenser Water Valve Solenoid, Auger Motor, Cube Motor

CN75 - FZ Fan Motor, FF Fan Motor, Compressor Fan Motor

CN76 - Ice Room Fan Motor

CN78 - FF LED Lights, Pantry Room Control, Water Tank Heater

CN90 - Icemaker, Icemaker Thermistor, Cycle Switch, Hall Sensors

CN91 - Pantry Room Damper

Note: Looking from behind the plugs into the board, pin#1 is always on the right side.

(Continued next page)

Power Supply Board

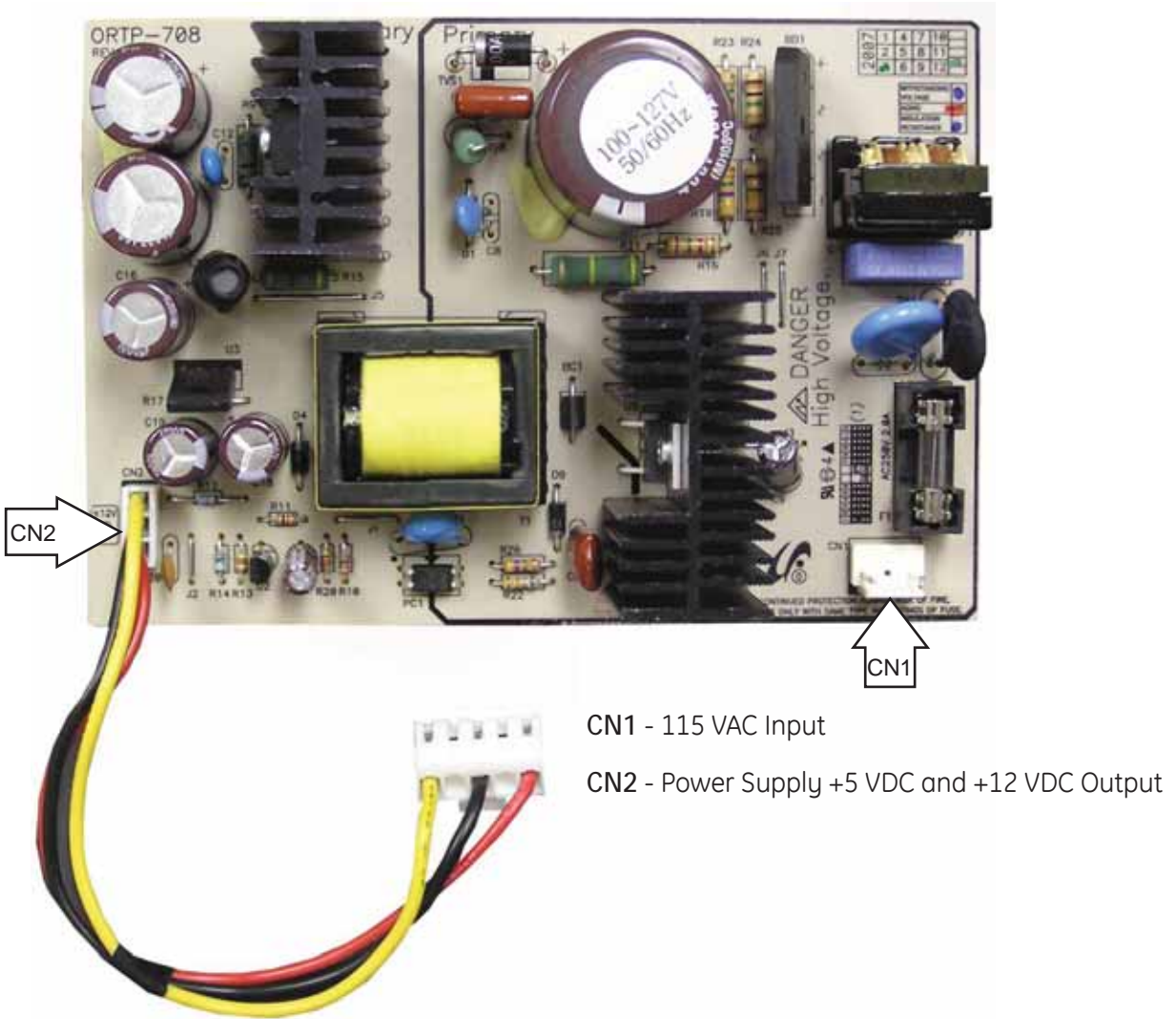

CN1 - 115 VAC Input
CN2 - Power Supply +5 VDC and +12 VDC Output

Fresh Food LED Light Board

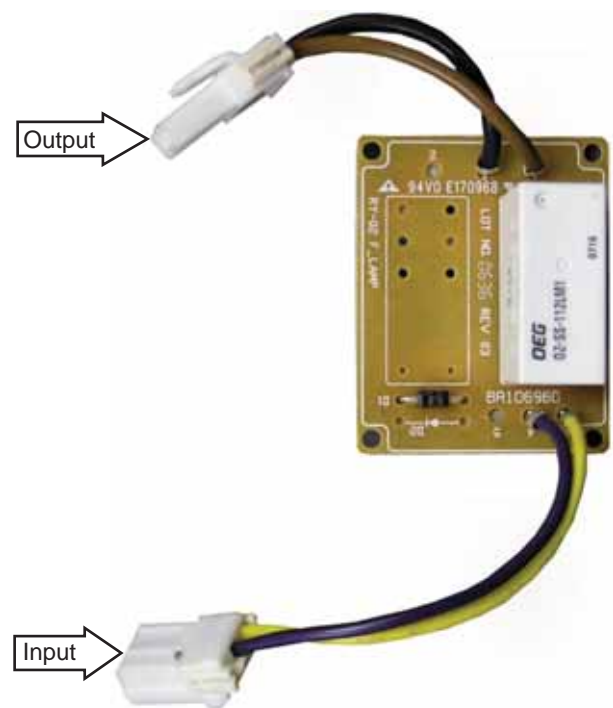

Components

Fresh Food Shelves and Bins

Rearranging the Shelves

Shelves in the refrigerator compartment are adjustable.

Refrigerator Compartment

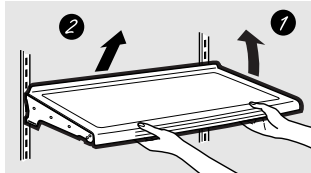

To remove:

- 1 Remove all items from the shelf.
- 2 Tilt the shelf up at the front.
- 3 Lift the shelf up at the back and bring the shelf out.

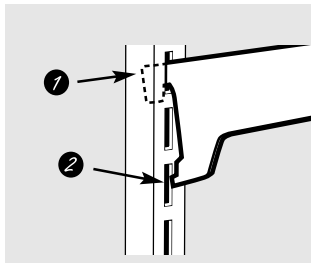

To replace:

- 1 While tilting the shelf up, insert the top hook at the back of the shelf in a slot on the track.
- 2 Lower the front of the shelf until the bottom of the shelf locks into place.

Spillproof Shelves

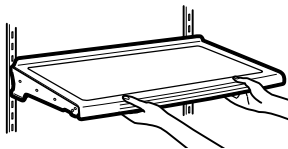

Spillproof shelves have special edges to help prevent spills from dripping to lower shelves.

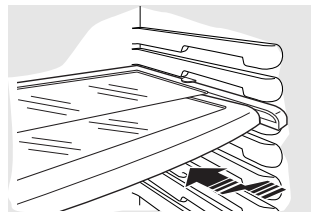

Quick Space Shelf

This shelf splits in half and slides under itself for storage of tall items on the shelf below.

This shelf can be removed and replaced or relocated (just like spillproof shelves).

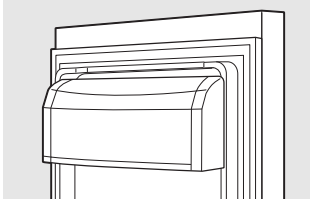

Non-Adjustable Dairy Bin

To remove: Lift the dairy bin straight up, then pull out.

To replace: Engage the bin in the molded door supports and push down. The bin will lock in place.

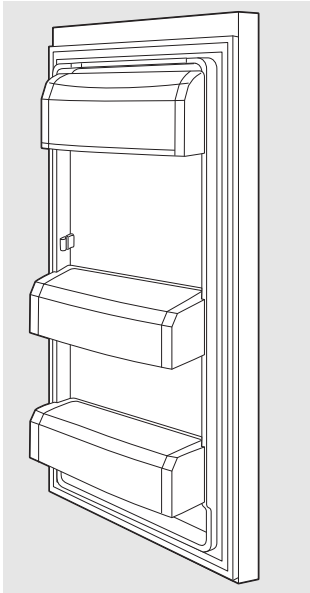

Adjustable Bins on the Door

Adjustable bins can easily be carried from refrigerator to work area.

To remove: Lift bin straight up, then pull out.

To replace or relocate: Slide in the bin just above the molded door supports, and push down. The bin will lock in place.

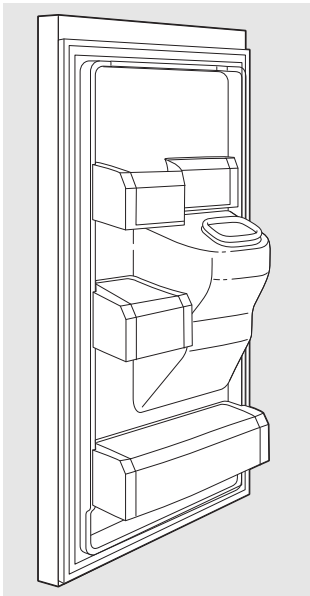

Non-Adjustable Bins on the Door

To remove: Lift the bin straight up, then pull out.

To replace: Engage the bin in the molded supports on the door and push down. It will lock in place.

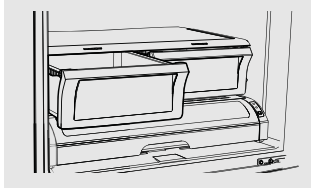

Fruit and Vegetable Crisper

Excess water that may accumulate in the bottom of the drawers or under the drawers should be wiped dry.

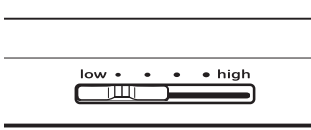

Adjustable Humidity Crisper

Slide the control all the way to the **high** setting to provide high humidity recommended for most vegetables.

Slide the control all the way to the **low** setting to provide lower humidity levels recommended for most fruits.

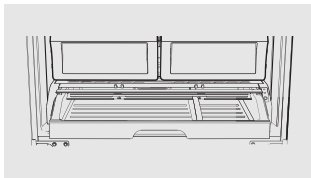

Adjustable Deli/Produce Drawer

The Adjustable Deli/Produce Drawer is a full-width drawer with adjustable temperature control. This drawer can be used for large miscellaneous items.

The control is located on the right side of the drawer.

There is a temperature control which can adjust the amount of cold air allowed into the drawer.

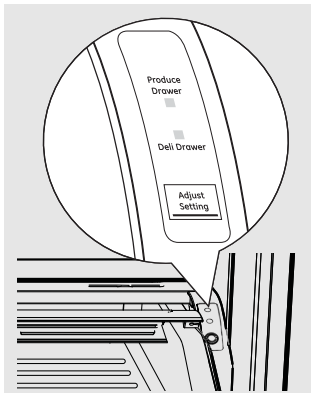

Control

When **Produce Drawer** is selected, the temperature of the drawer can be kept around 38°F (3°C). This feature also helps keep food fresh for a long time.

NOTE: Fruits and vegetables may be damaged using the **Deli Drawer** setting. Do not store lettuce or other leafy produce in this drawer.

When **Deli Drawer** is selected, the temperature of the drawer can be kept around 34°F (1°C). This feature also helps keep meat or fish fresh for a longer time.

CAUTION: Do not store glass bottles in this drawer. If they are frozen, they can break and cause personal injury.

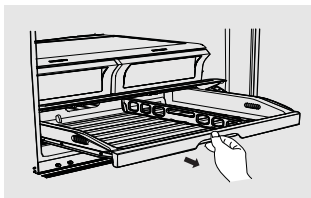

How to Remove and Replace the Adjustable Deli/Produce Drawer

To remove:

- 1 Pull the drawer out to the stop position.
- 2 Lift the front of the drawer up and out.

To replace:

- 1 Lift the cover up.
- 2 Engage the pantry rollers into the side rails.
- 3 Push the drawer inwards (until it is in place).

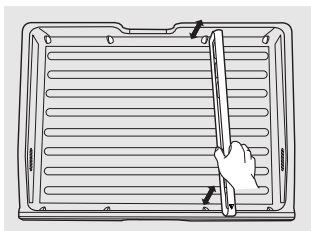

How to Remove and Replace Drawer Divider

To remove:

- 1 Pull the drawer out to the stop position.
- 2 Raise the front side of the divider to unhook it from the rear wall of the drawer.

To replace:

- 1 Hook the back of the divider over the rear wall of the drawer.
- 2 Push the divider down.

Freezer Basket and Drawer

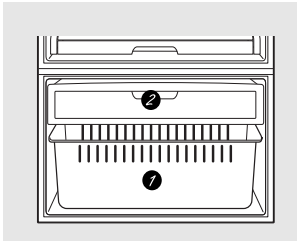

- ① Basket.
- ② Drawer.

Non-Adjustable Bins in the Freezer

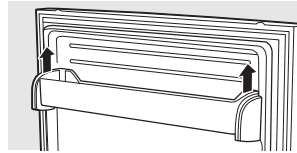

To remove: Pull the brackets upward until you hear a clicking sound and remove the bin.

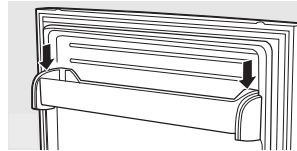

To replace: Hook the ends of the bin into both brackets and push down until the bin locks into place.

Basket Removal

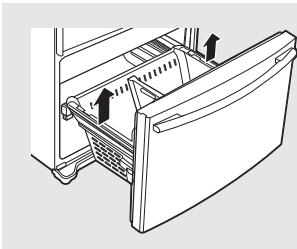

To remove:

- ① Remove Freezer Bin.
- ② Pull basket out to the stop position.
- ③ Tilt up the rear of the bin.
- ④ Lift it out to remove.

To replace:

- ① Place the basket into the rail assembly.

Basket Divider Removal

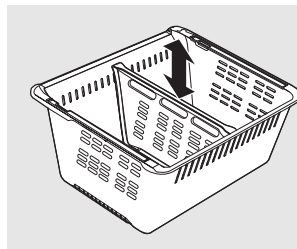

To remove:

- ① Pull basket out to the stop position.
- ② Tilt up the rear of the bin.
- ③ Lift it out to remove.

To replace:

- ① Hook the top corners of the divider over the hole of the basket.

Drawer Removal

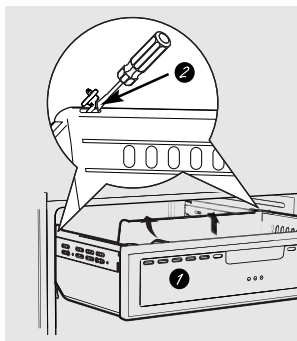

To remove:

- ① Pull the drawer out to the stop position.
- ② Remove both side knobs with a flat-head screwdriver.
- ③ Tilt up the rear of the drawer and lift straight out.

To replace:

- ① Pull both rails out to the stop position.
- ② Place the drawer onto the rails and hook the support into the slots located on the side of the drawer.
- ③ Replace the side knob and push the drawer back into place.

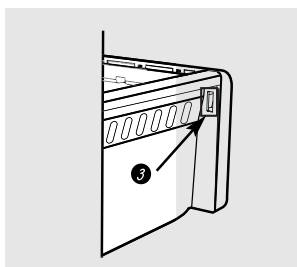

⚠ WARNING: Please do not lose the side knobs during disassembly since they may present a choking hazard to children.

Top Table

The top table is located on top of the refrigerator. The top table houses 2 reed switches and covers both door hinges, ambient sensor, wire harnesses, and the dispenser water tubing disconnect. Two hinge tabs position the top table over both door hinges and 3 screws attach it to the cabinet.

To remove the top table:

1. Open both doors.
2. Insert a small flat blade screwdriver under each of the 2 top table caps, and carefully pry them away from the top table.



3. Remove the 3 recessed Phillips-head screws that hold the top table to the cabinet.
4. Pull each side of the top table up to release each hinge tab.

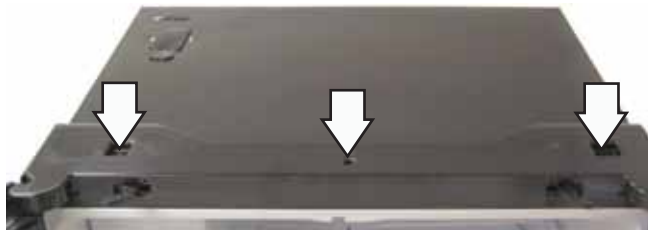

5. Place the top table upside-down on top of the cabinet and disconnect both reed switch wire harnesses.

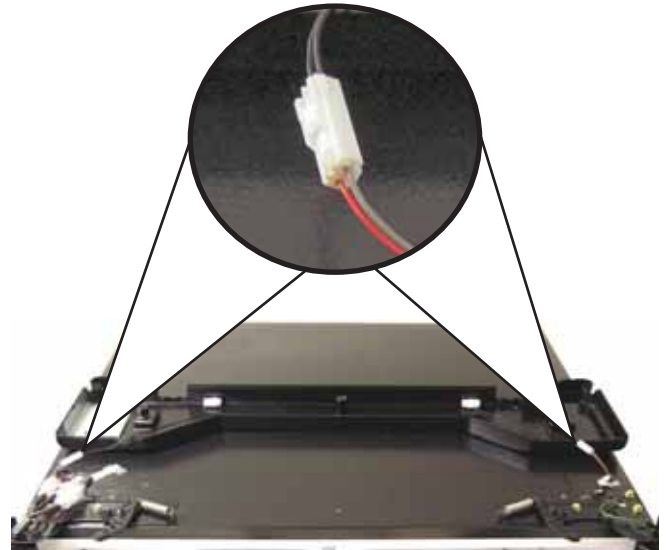

Door Reed Switches and Door Magnets

The top table houses 2 reed switches, (1 for each door). Each switch informs the main control board the status of each door, whether it is open or closed. Each switch is activated by a magnet recessed in the top of each door.

Replacement table tops are supplied with the switches installed. The switches are also available separately.

To replace the reed switches, it is necessary to remove the top table (See *Top Table*.) and place it inside-up on a protective surface.

Note: The reed switches may be lightly glued to the top table. It will be necessary to carefully pry and separate the switch from the glue.

Each reed switch is held in place by small tabs that can be carefully pried back.

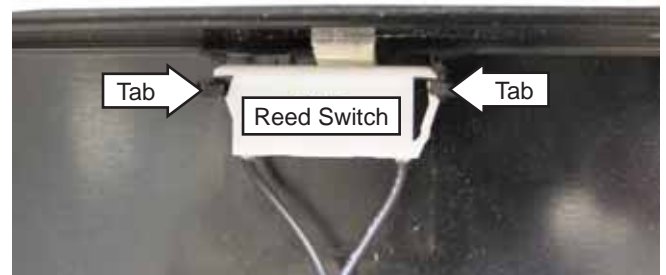

Each door magnet is located in a recess at the top of each door. Using a small flat blade screwdriver, each magnet can be removed by carefully prying each side out from the recess.

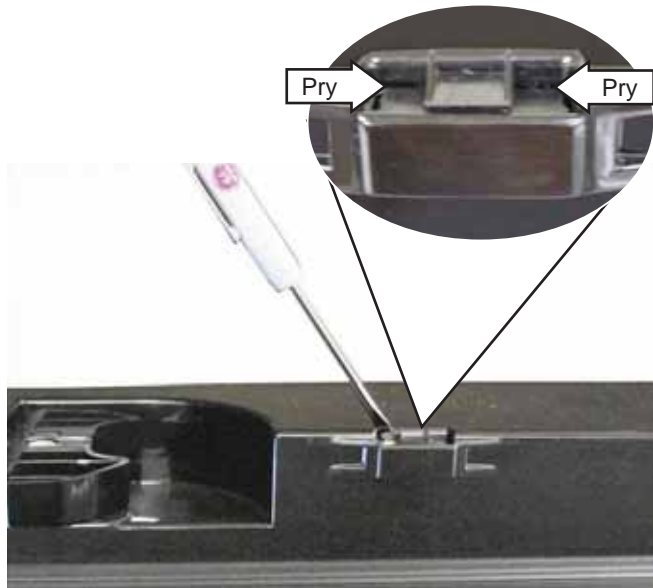

Door Gaskets

The fresh food and freezer doors have magnetic gaskets that create a positive seal to the front of the steel cabinet. The magnetic door gaskets are secured to the doors by a barbed edge that locks into a retainer channel.

To remove and replace the door gasket:

1. Starting at any corner, pull the old gasket out of the retaining channel.
2. Soak the new gasket in warm water to make it pliable.
3. Push the barbed edge of the gasket into the retainer channel.



Interior Lights

Freezer Light

To replace the freezer light:

1. Unplug the refrigerator.
2. Remove the freezer upper drawer. (See *Control Features*.)
3. Press in on the back of the light cover then lower it down and out.



4. Replace the bulb with an appliance bulb of the same or lower wattage, and reinstall the light cover.

Note: When reinstalling the light cover, make sure all top tabs snap securely in place.

5. Reinstall the upper drawer and plug the refrigerator back in.

Refrigerator LED Light

To replace the refrigerator LED light:

1. Unplug the refrigerator.
2. Press in on the back of the LED light cover then lower it down.



(Continued next page)

3. Remove the 2 Phillips-head screws that hold the LED light housing to the ceiling of the refrigerator.



4. Disconnect the LED light and the sensor wire harnesses.

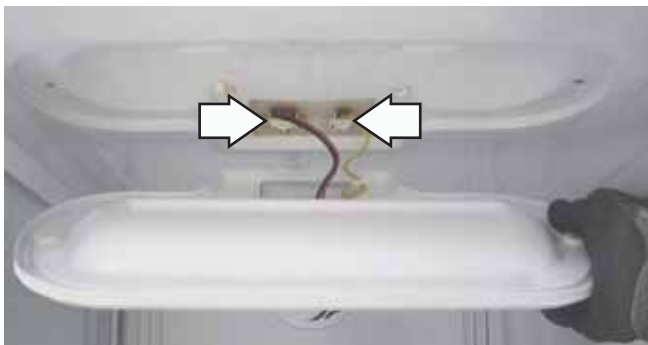

5. Remove the 2 Phillips-head screws and the LED board.



Fresh Food Evaporator Cover

The fresh food evaporator cover is held to the back wall of the refrigerator with a Phillips-head screw and 2 tabs.

To remove the fresh food evaporator cover:

1. Remove the 2 fruit and vegetable drawers and the shelves that are in front of the evaporator cover.
2. Using a small flat blade screwdriver, pry off the cap from the top of the shelf angle.



3. Remove the 2 Phillips-head screws that attach the shelf angle to the cover.
4. Remove the 2 Phillips-head screws that hold the evaporator cover to the back wall.

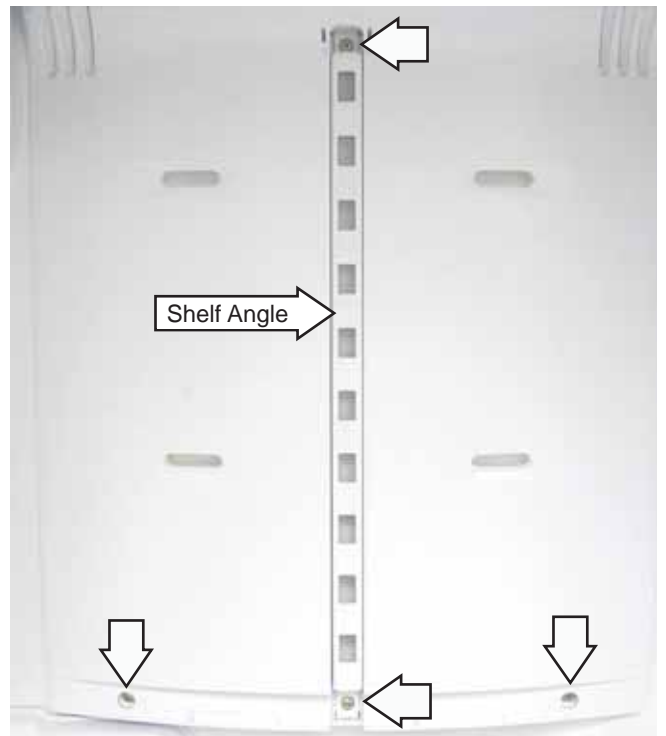

(Continued next page)

5. Grasp the shelf angle near the bottom and pull it out and down.



6. Pull the cover out at the bottom, then lower the cover.



Note: Behind the cover there is a recessed area in the back wall that houses the evaporator assembly. The top of the cover is inserted into the top of the recess and the sides have small arrows that indicate the location of 6 tabs that lock into the recess.

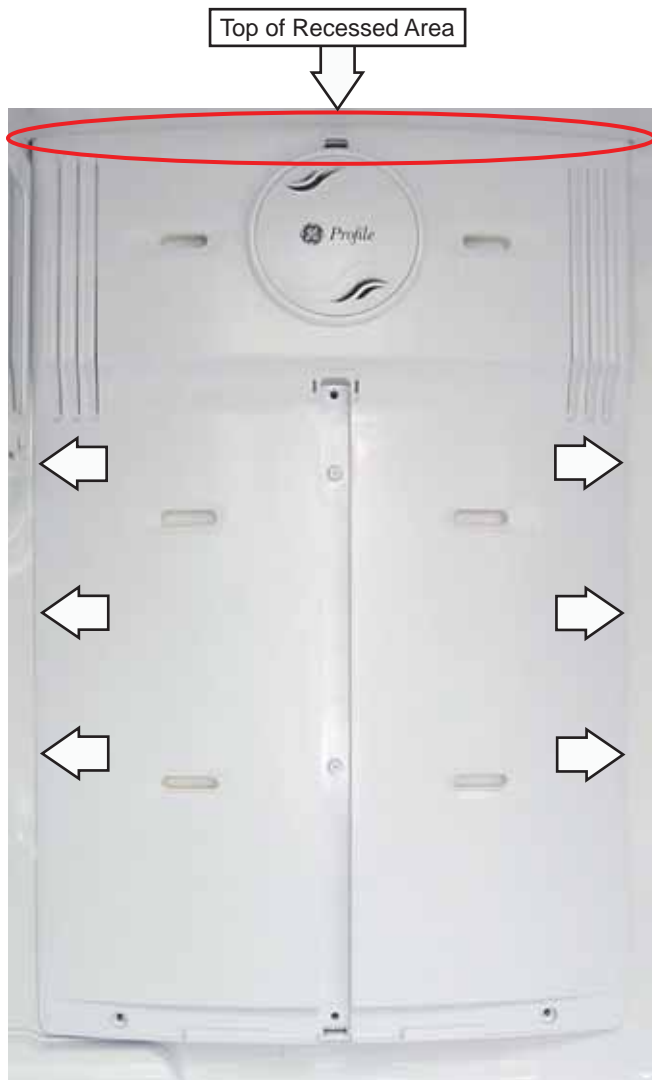

7. Turn the front of the cover towards the icemaker and disconnect the evaporator fan motor wire harness.

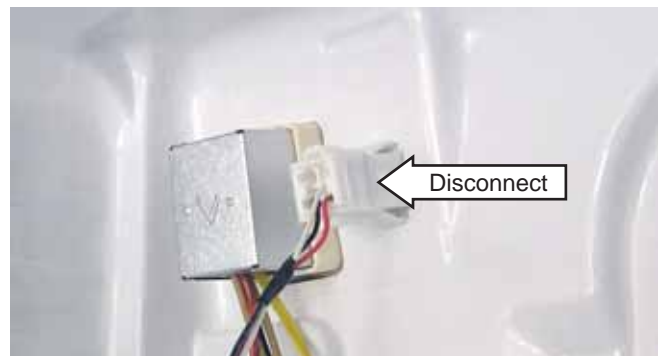

Fresh Food Evaporator

WARNING: Sharp edges may be exposed when servicing. Use caution to avoid injury. Wear Kevlar gloves or equivalent protection.

The following components must be removed in the appropriate order to access the fresh food evaporator:

1. Remove the fresh food evaporator cover. (See *Fresh Food Evaporator Cover*.)
2. Push in the sides of the housing cover and pull out the cover.



3. Disconnect the 3 fresh food evaporator defrost component harnesses.

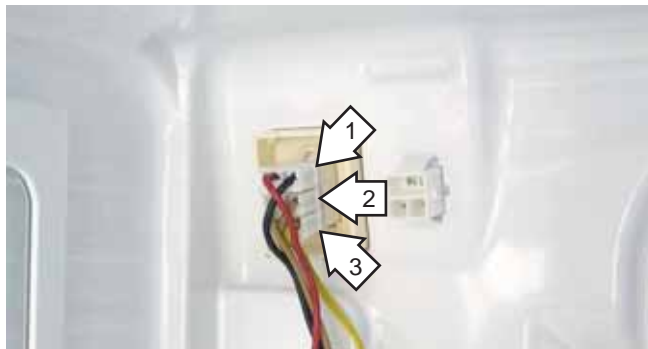

Defrost Components		
No.	Component	Wire Colors
1	Bimetal Thermostat	Red and Black
2	Defrost Heater	Tan
3	Thermistor	Yellow

4. Peel off the reflective tape from the drain tray.
5. Remove the 2 Phillips-head screws that hold the evaporator to the back wall of the refrigerator.
6. Carefully pull the evaporator up to remove the heat conducting tab from the drain inlet in the recess.

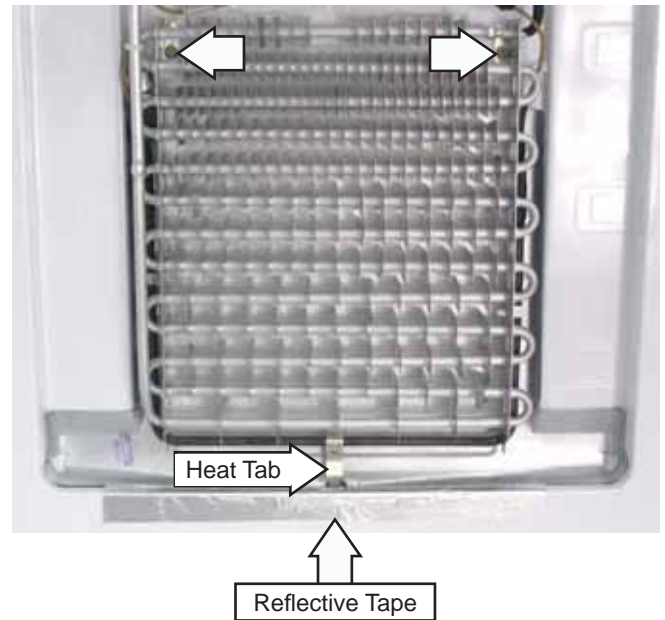

Freezer Evaporator Cover

The freezer evaporator cover is held to the back wall of the refrigerator with 2 recessed Phillips-head screws.

To remove the freezer evaporator cover:

1. Remove the freezer basket and drawer. (See *Freezer Basket and Drawer*.)
2. Remove the four 10-mm hex-head bolts (2 on each side) that attach the drawer front to the rail assembly.



(Continued next page)

3. Tilt the bottom of the drawer out and lift the drawer off the rail assembly.
4. Place the drawer front on a protected surface.



5. Using a flat blade screwdriver, press in the rail lock tab on the left side rail cover then slide the rail out slightly to cover the lock tab. Repeat this procedure on the right-side rail.



6. Evenly pull the rail assembly away from the refrigerator until both rails are clear of the cabinet.

Note: Behind the cover there is a recessed area in the back wall that houses the evaporator assembly. The cover is held in place by 2 recessed Phillips-head screws and 3 tabs inserted into the bottom of the recess.

7. Remove the 2 recessed Phillips-head screws that attach the cover to the back wall of the freezer compartment.



8. Lift the bottom of the cover up and pull cover towards the front of the refrigerator.



9. Disconnect the 3 freezer evaporator cover component harnesses.

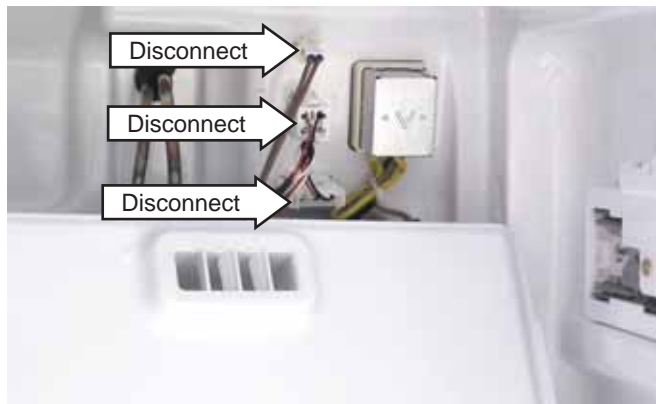

Freezer Evaporator

WARNING: Sharp edges may be exposed when servicing. Use caution to avoid injury. Wear Kevlar gloves or equivalent protection.

The following components must be removed in the appropriate order to access the freezer evaporator:

1. Remove the freezer evaporator cover. (See *Freezer Evaporator Cover*.)
2. Push in the sides of the housing cover and pull out the cover.



3. Disconnect the 3 freezer evaporator defrost component harnesses.



Defrost Components		
No.	Component	Wire Colors
1	Bimetal Thermostat	Red and Black
2	Defrost Heater	Tan
3	Thermistor	Yellow

4. Pull out the foam block from the right side of the evaporator.



5. Peel off the reflective tape from the drain tray.

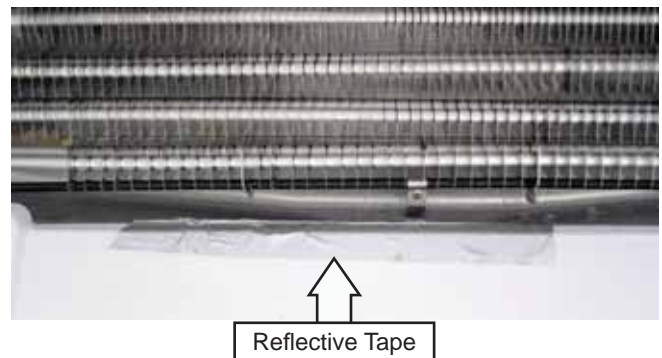

6. Carefully pull the evaporator out and up to remove the heat conducting tab from the drain inlet in the recess.



Replacing Evaporators Using the LOKRING Method

Fresh Food Evaporator

Parts Needed:

- Fresh Food Evaporator
- Drier Assembly
- Access Tube (part # WJ56X61)
- LOKRING Connectors- (part # WR97X10031)
(part # WR97X10085)
(part # WR97X10021)

Freezer Evaporator

Parts Needed:

- Freezer Evaporator
- Drier Assembly
- Access Tube (part # WJ56X61)
- LOKRING Connectors- (2 of part # WR97X10021)

The LOKRING method provides a durable, vibration resistant compression connection for both copper and aluminum tubing. The connectors can be used within a temperature range of -58°F (-50°C) to +302°F (150°C) and showed to have a higher burst strength than that of the tube itself. Refer to Service Guide #31-9067 for complete instructions on using the LOKRING method of installing an evaporator.

Freezer Fan

The freezer fan is attached to the inside of the freezer evaporator cover.

To remove the freezer fan assembly:

1. Remove the freezer evaporator cover (See *Freezer Evaporator Cover*.) and place the cover assembly on a protected surface so that the inside faces upward.
2. Note the positioning of the wiring and untape the wire harnesses.

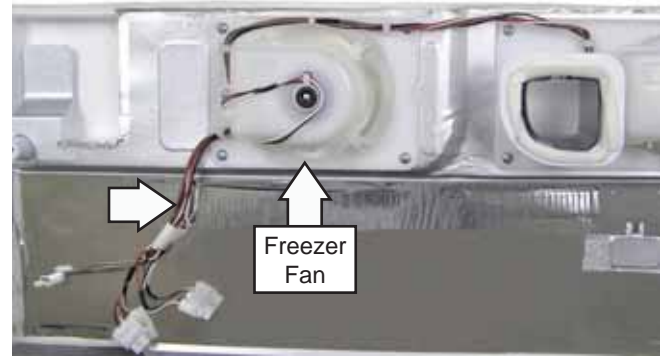

3. Remove the plastic wire tie and the freezer fan wires from the retainer.
4. Remove the 4 Phillips-head screws that attach the fan housing to the evaporator cover.

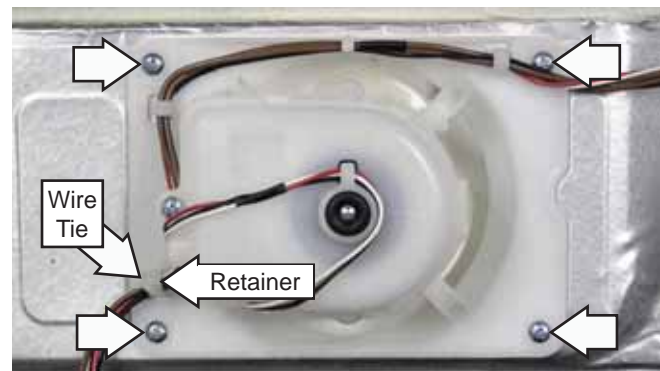

(Continued next page)

5. Remove the fan housing and place it blade side up on the protected surface.

Note: An anti-slip adhesive is applied to the fan blade hub during factory assembly and the fan blade may be difficult to remove.

6. Using 2 large flat blade screwdrivers, place each screwdriver under the fan blade hub, 180° apart, and over 2 opposite legs of the housing as shown. Carefully pry up and remove the fan blade from the motor shaft.



7. Remove the 2 Phillips-head screws, then rotate the fan motor 90° counterclockwise and remove the motor from the fan housing.



Ice Room Blower

The ice room blower is attached to the inside of the freezer evaporator cover.

To remove the ice room blower assembly:

1. Remove the freezer evaporator cover (See *Freezer Evaporator Cover*.) and place the cover assembly on a protected surface so that the inside faces upward.
2. Note the positioning of the wiring and untape the wire harnesses.
3. Remove the 2 plastic wire ties (not shown) and the blower wires from all retainers.
4. Remove the 4 Phillips-head screws that attach the blower housing to the evaporator cover.

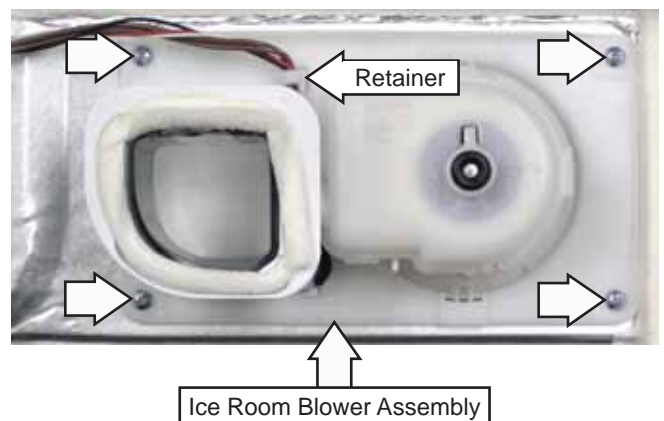

- Remove the blower housing and place it blower wheel-side up on the protected surface.

Note: An anti-slip adhesive is applied to the blower wheel hub during factory assembly and the blower wheel may be difficult to remove.

- Firmly grasp the blower wheel and pull it off the motor shaft.



- Remove the 2 Phillips-head screws then rotate the blower motor 90° counterclockwise and remove the motor from the blower housing.

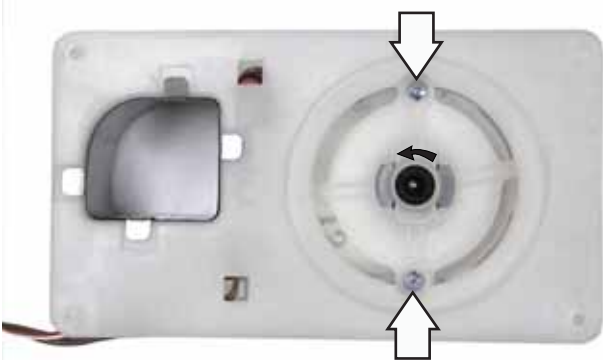

Fresh Food Fan

The fresh food fan motor is attached to the inside of the fresh food evaporator cover.

To remove the fresh food fan:

- Remove the fresh food evaporator cover. (See *Fresh Food Evaporator Cover*.)
- Peel off the masking tape from the top and the reflective tape from the bottom of the fan motor housing.
- Remove the 4 Phillips-head screws that attach the fan housing to the evaporator cover.

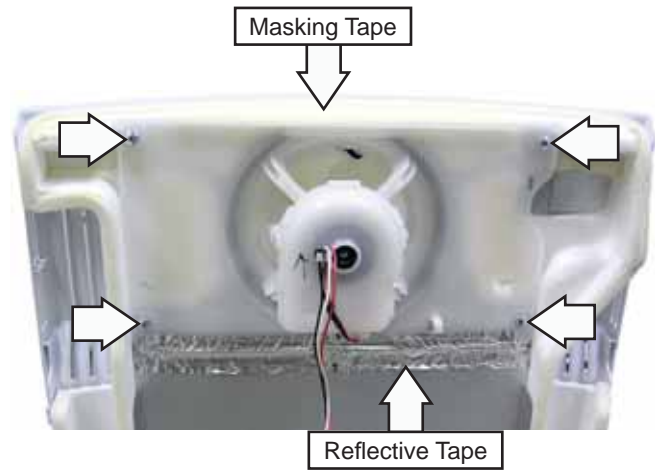

Note: The fan blade may be difficult to remove from the motor shaft. Care must be taken to avoid damage to the fan blade and/or fan housing.

- Place the fan housing blade side up on a protective surface.
- Using 2 large flat blade screwdrivers, place each screwdriver under the fan blade hub, 180° apart, and over 2 opposite legs of the housing as shown. Carefully pry up and remove the fan blade from the motor shaft.

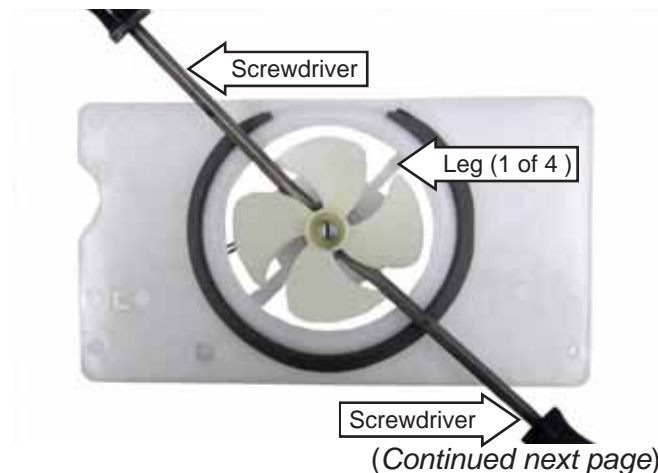

(Continued next page)

- Remove the 2 Phillips-head screws, then rotate the fan motor 1/4-turn counterclockwise and remove the motor from the fan housing.

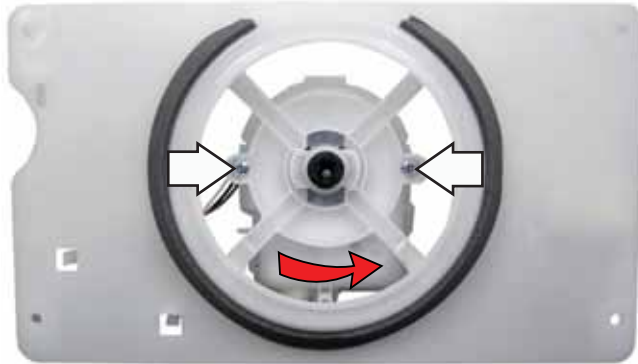

Machine Compartment Cover

The machine compartment cover is held to the rear of the refrigerator with 8 Phillips-head screws and 2 tabs. After removing the screws the cover can then be lifted from the tabs.

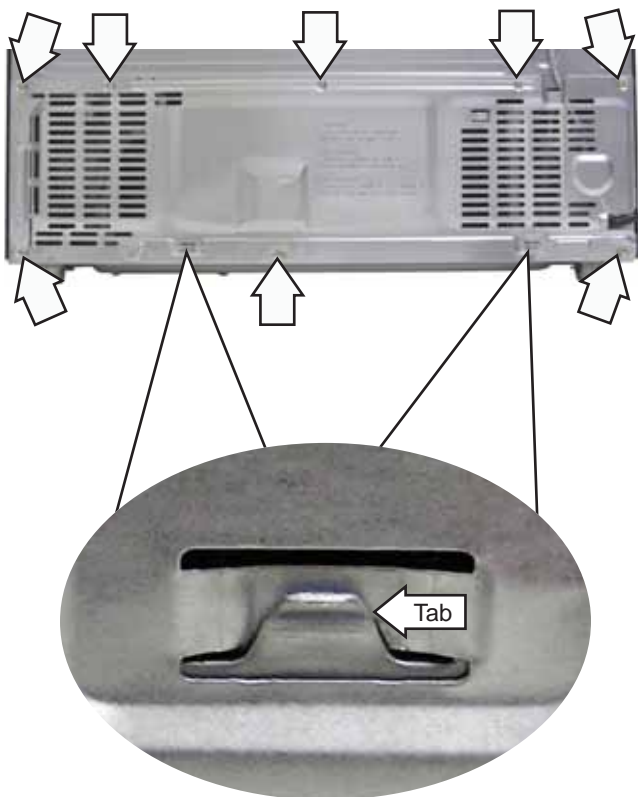

Note: When installing the machine compartment cover, be sure to place the cover over the 2 tabs before installing screws.

Condenser Fan

The condenser fan motor is mounted in the machine compartment between the compressor and the condenser. The machine compartment cover must be properly installed to ensure air passes through the condenser. (See *Machine Compartment Cover*.)

Condenser Fan Parameters

Room Temperature	Condenser Fan Operation
Above 66°F	Fan operates with compressor.
61 - 65°F	Fan has 5-minute delay, then operates with compressor.
Below 60°F	Condenser fan does not operate at all.

To remove the condenser fan:

- Remove the machine compartment cover. (See *Machine Compartment Cover*.)
- Disconnect the fan wire harness.
- Using a flat blade screwdriver or fingertip, simultaneously lift the front tab of the fan housing and pull the fan assembly out approximately 1 inch.

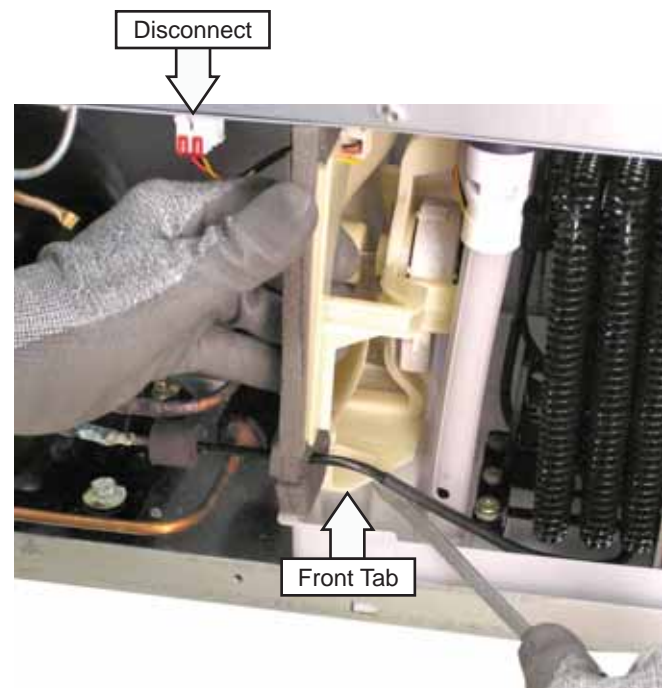

4. Rotate the fan assembly clockwise then carefully maneuver the fan assembly out of the machine compartment.



7. Note the routing of the wiring through the retainers and the position of the motor and clamp. Remove the wiring from the retainers.

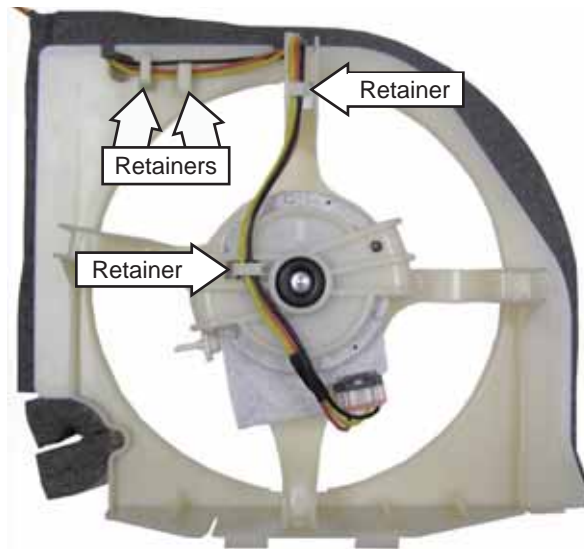

5. Using a flat blade screwdriver, remove the spring clip.

6. Pull the fan blade off the motor shaft.

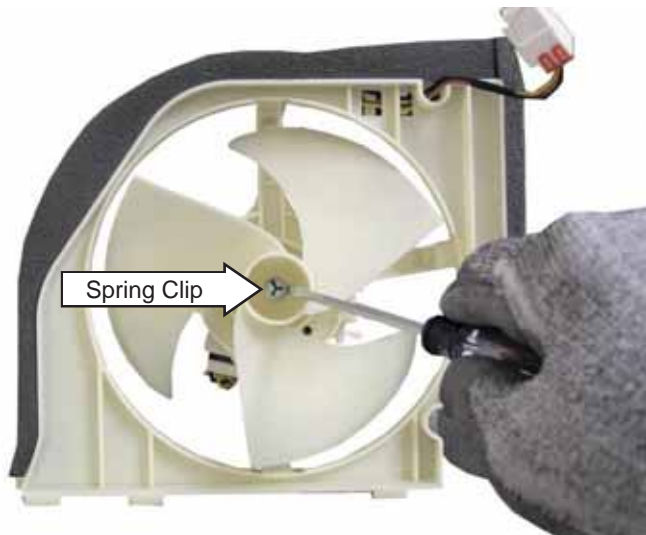

8. Remove the 2 Phillips-head screws from the fan housing.

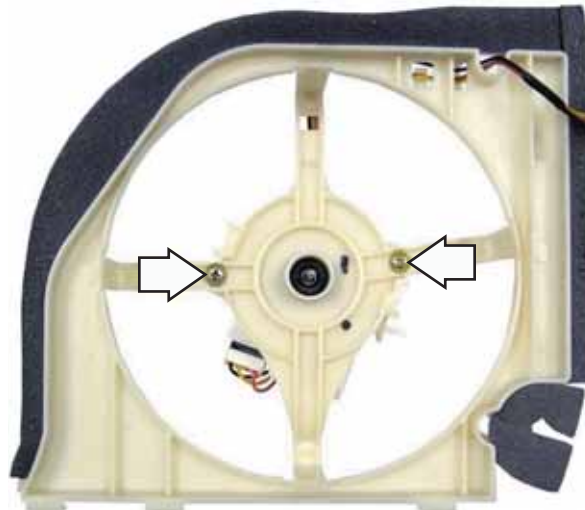

9. Using a flat blade screwdriver or fingertips, lift and spread each of the 2 tabs on the motor clamp and pull the fan motor out of the housing.

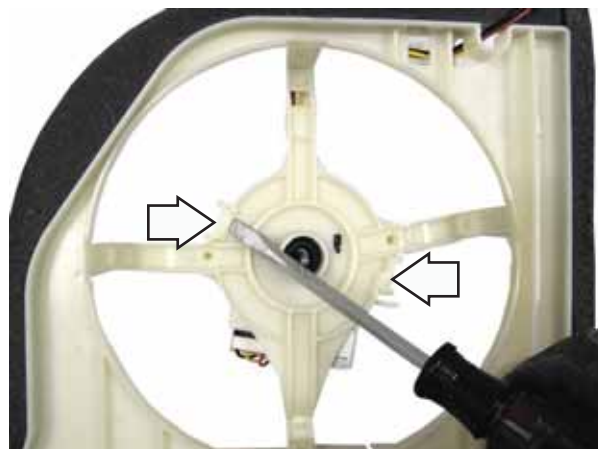

Thermistors

Thermistor Resistance		
Temperature (°F)	Temperature (°C)	Resistance in Kilo-Ohms
-40	-40	88 kΩ
-31	-35	67.6 kΩ
-22	-30	52.4 kΩ
-13	-25	40.9 kΩ
-4	-20	32.2 kΩ
5	-15	25.6 kΩ
14	-10	20.4 kΩ
23	-5	16.4 kΩ
32	0	13.2 kΩ
41	5	10.8 kΩ
50	10	8.9 kΩ
59	15	7.3 kΩ
68	20	6.1 kΩ
77	25	5 kΩ
86	30	4.2 kΩ
95	35	3.5 kΩ
104	40	3 kΩ
113	45	2.5 kΩ
122	50	2.2 kΩ
131	55	1.9 kΩ
140	60	1.6 kΩ

Note: To accurately test a thermistor, place the thermistor in a glass of ice water (approximately 33°F (0.5°C)) for several minutes and check for approximately 12.7K Ω.

Fresh Food Thermistor

The fresh food thermistor is inserted in a recess located in the back of the fresh food LED light housing.

To access the thermistor it is necessary to remove the LED light housing. (See *Interior Lights*.)



The thermistor recess is covered with a foam insulator that must be peeled back to remove the thermistor.

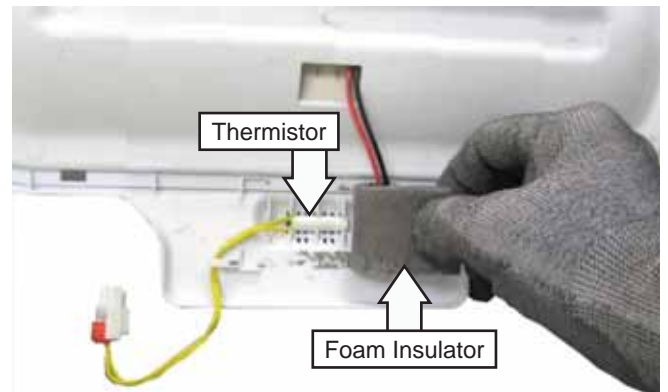

Freezer Thermistor

The freezer thermistor is inserted in the thermistor cover located in the ceiling of the freezer compartment behind the light. To access the thermistor it is necessary to remove the freezer basket and drawer. (See *Freezer Basket and Drawer*.)

To remove the thermistor cover, insert a flat blade screwdriver under the cover and gently pry the cover from the ceiling.

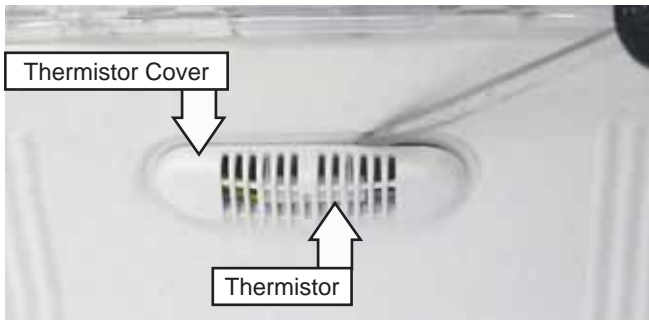

The thermistor is connected to the refrigerator with a wire harness.



Fresh Food Evaporator Thermistor

To access the fresh food evaporator thermistor the fresh food evaporator cover must be removed. (See *Fresh Food Evaporator Cover*.) The housing cover can be removed to disconnect the wire harnesses to the thermistor. (See *Fresh Food Evaporator*.)

The fresh food thermistor is located on the evaporator inlet tube.

The thermistor wiring is attached to the evaporator with 2 plastic wire ties and is held to the inlet tube with a plastic clamp. The 2 tabs on the clamp can be pried open to release the thermistor.

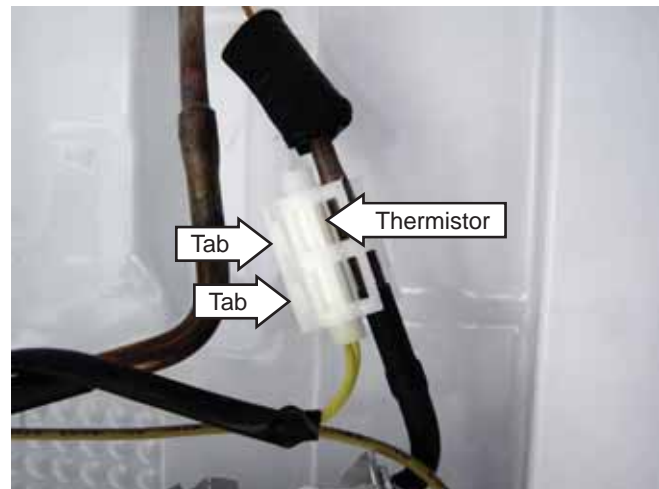

(Continued next page)

Freezer Evaporator Thermistor

To access the freezer thermistor the freezer evaporator cover must be removed. (See *Freezer Evaporator Cover*.) The housing cover can be removed to disconnect the wire harness to the thermistor. (See *Freezer Evaporator*.)

The freezer thermistor is located in a plastic holder attached to the evaporator.

The thermistor holder and the thermistor wiring are attached to the evaporator with 3 plastic wire ties. After the plastic wire ties are removed, the thermistor can be pulled out of the holder.

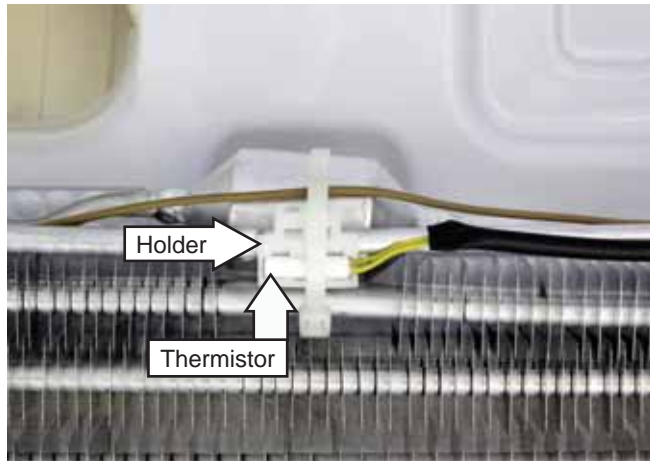

Ice Room Thermistor

The ice room thermistor is inserted in the auger motor cover. To replace the ice room thermistor the auger motor assembly must be removed. (See *Auger Motor Assembly*.)

The thermistor is connected to the auger motor assembly with a wire harness.



Pantry Thermistor

The pantry thermistor is inserted in the damper cover.

To replace the pantry thermistor:

1. Remove the damper assembly. (See *Damper Assembly*.)
2. Peel off the foam that seals the damper cover to the back wall of the refrigerator.



3. Carefully pull out the damper assembly from the damper cover.



4. Pull out the pantry thermistor from the damper cover.

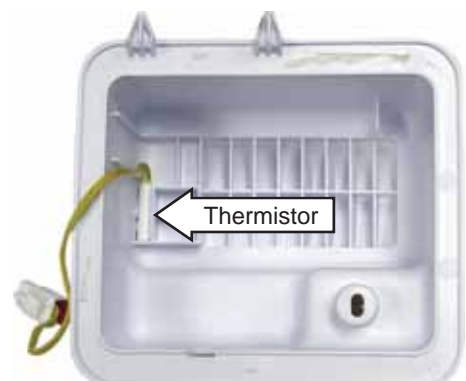

(Continued next page)

Ambient Thermistor

The ambient thermistor is located under the right side of the top table.

To replace the ambient thermistor:

Note: In the following step you do not need to disconnect both reed switch wire harnesses.

1. Remove the top table. (See *Top Table*.)
2. Cut off the thermistor leads where they enter the thermistor body.

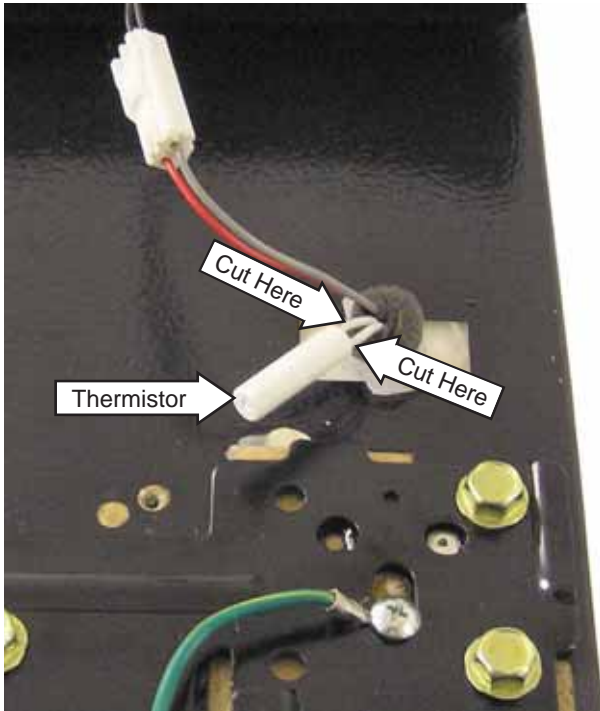

3. Use plastic bell connectors and fill the connector with RTV102 silicone then splice a new thermistor into the wires as shown in the illustration.

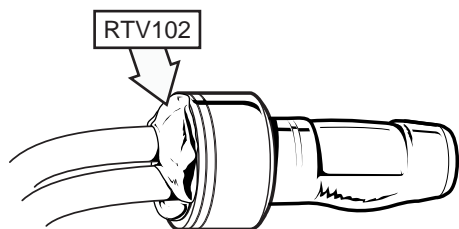

Over Temperature Thermostats

Fresh Food Over Temperature Thermostat

The over temperature thermostat is attached on a bracket located on the top left side of the evaporator. (See *Component Locator Views*.)

The thermostat wiring is attached to the evaporator with 2 plastic wire ties and the thermostat is held to the bracket with a metal clip. It is necessary to remove the FF evaporator from the recess to replace the over temperature thermostat. (See *Fresh Food Evaporator*.)

Left Side View of Evaporator

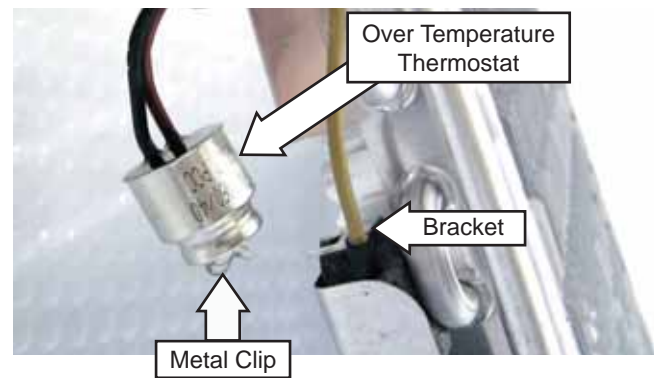

Freezer Over Temperature Thermostat

The over temperature thermostat is attached on a bracket located on the top right side of the evaporator. (See *Component Locator Views*.) The thermostat wiring is attached to the evaporator with a plastic wire tie and the thermostat is held to the bracket with a metal clip.

Top Right View of Evaporator

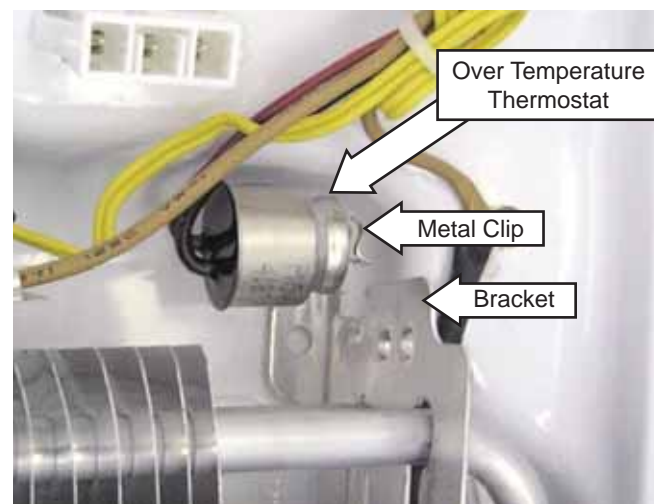

Defrost Heaters

Fresh Food Defrost Heater

The defrost heater is located on the sides and bottom of the evaporator.

The defrost heater wiring is attached to the evaporator with 4 plastic wire ties and the heater is held in 2 slots (1 on each side) at the bottom of the evaporator.

To remove the defrost heater:

1. Carefully bend open the tabs that form the 2 slots and pull down the heater.
2. Carefully pull the bottom of the evaporator approximately 45 degrees from the recess.

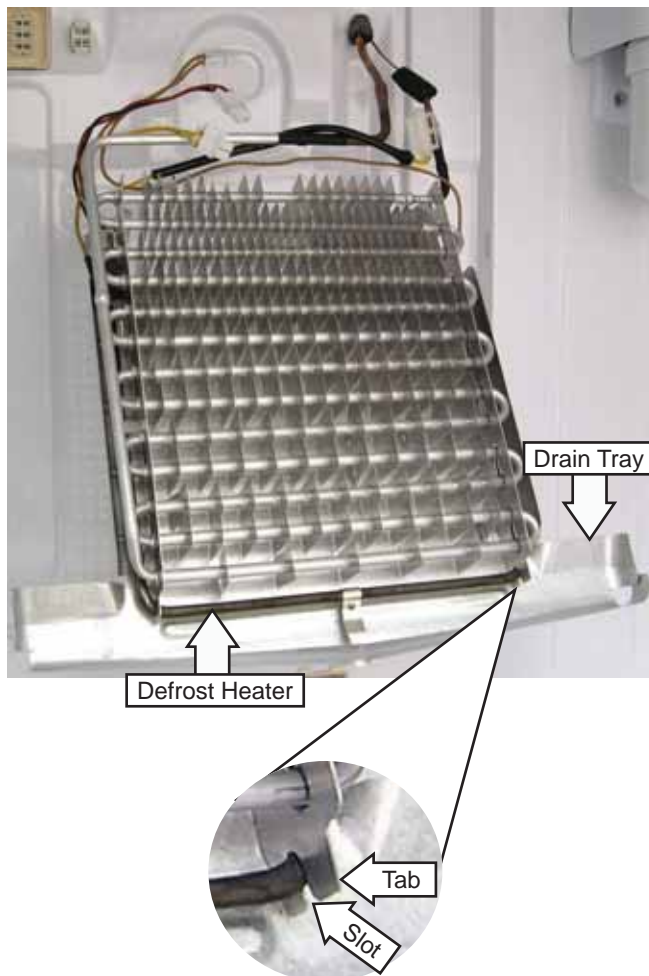

3. Using a small flat bladed screwdriver, reach behind the drain tray and bend straight the 4 lock tabs that hold the evaporator to the drain tray.

Rear View of Drain Tray



4. Separate the drain tray from the evaporator.
5. Remove the defrost heater from the evaporator.

Note: When installing the heater to the drain tray, be sure heat tab is inserted into the drain tray outlet.

Freezer Defrost Heater

The defrost heater is located on the sides and bottom of the evaporator.

The defrost heater wiring is attached to the evaporator with 4 plastic wire ties and the heater is held in 4 slots) at the bottom of the evaporator.

To remove the defrost heater:

1. Remove the 4 plastic wire ties.
2. Remove the foam air block.



3. Peel off the reflective tape.
4. Carefully bend open the tabs that form the 4 slots and pull down the heater.
5. Carefully pull the evaporator out and up to remove the heat conducting tab from the drain inlet in the recess.

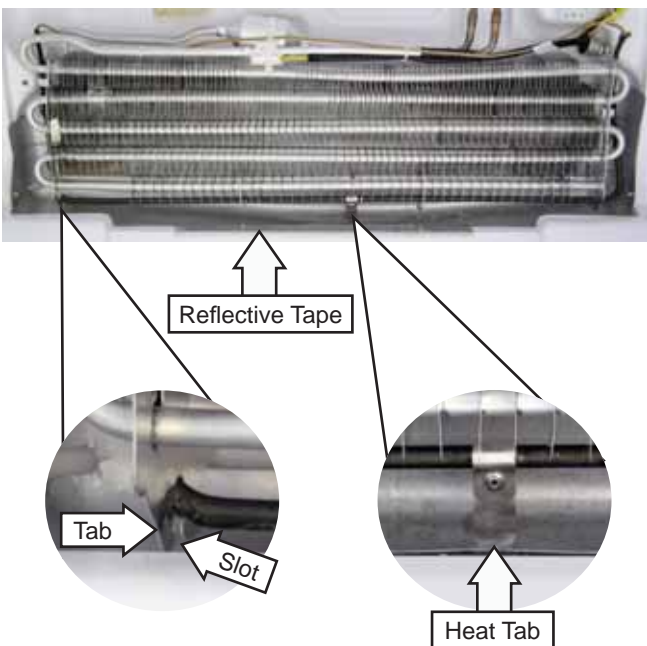

6. Using a small flat bladed screwdriver, reach behind the drain tray and bend straight the 2 lock tabs that hold the evaporator to the drain tray.

Rear View of Drain Tray



7. Separate the drain tray from the evaporator.
 8. Remove the defrost heater from the evaporator.
- Note:** When installing the heater to the drain tray, be sure heat tab is inserted into the drain tray outlet.

Duct Heater

The duct heater is attached to the inside of the freezer evaporator cover. The duct heater prevents water from freezing and blocking air flow to the ice room.

The duct heater is in a parallel circuit with the freezer defrost heater. The heaters are in series with the bimetal defrost safety thermostat. Both heaters operate at 120 VAC when the freezer defrost circuit is energized by the main control board and the defrost safety thermostat is closed.

(Continued next page)

The heater can be checked directly as a separate component by removing the freezer evaporator cover (See *Freezer Evaporator Cover*.) The heater wire harness can then be disconnected.

The duct heater has a resistance value of approximately 3.18K Ω .



To remove the duct heater:

1. Remove the freezer evaporator cover (See *Freezer Evaporator Cover*.) and place the cover assembly on a protected surface so that the inside faces upward.
2. Note the positioning of the wiring and untape the wire harnesses.
3. Remove the 2 plastic wire ties (not shown) and the duct heater wires from all retainers.

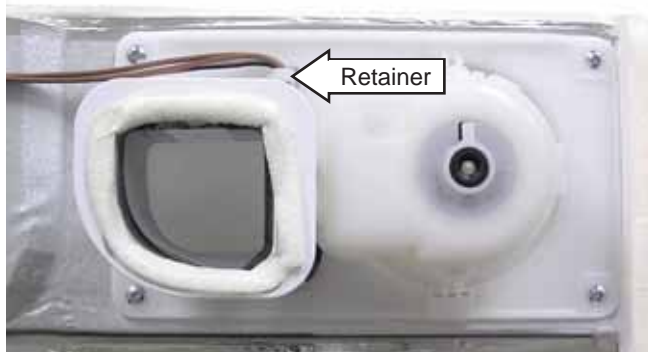

4. Press inward the top and bottom tabs and pull the duct assembly from the ice room blower housing.

Top View of Duct

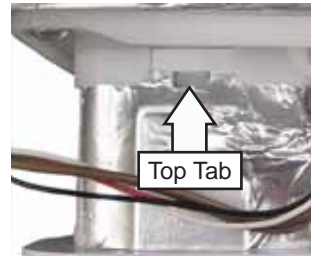

Bottom View of Duct



EMI Filter and Power Cord

It is necessary to remove the EMI filter to replace the power cord. The power cord is connected to the EMI filter with a wire harness.

To remove the EMI filter and power cord:

1. Remove the machine compartment cover. (See *Machine Compartment Cover*.)
2. Remove the Phillips-head screws that hold the EMI filter bracket, water valve, power cord, and ground wires to the cabinet.
3. Disconnect the EMI filter wire harness.

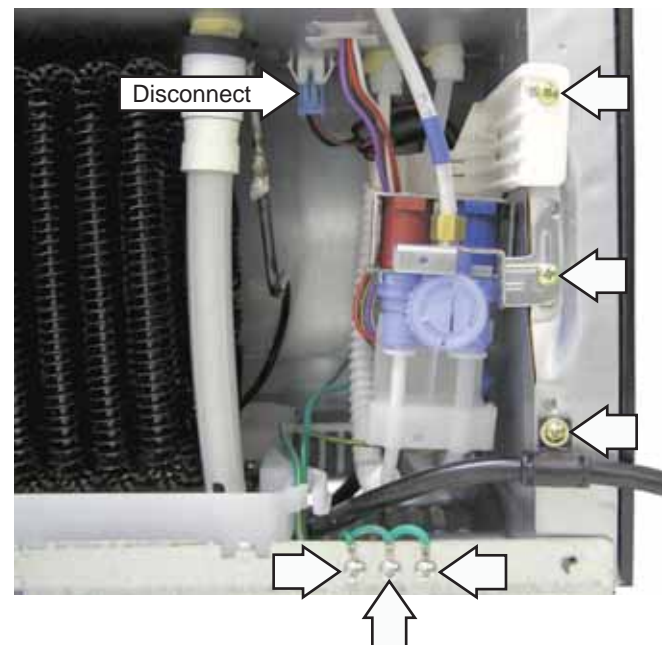

4. Position the water valve to the left side.
5. Pull the EMI filter bracket straight out.
6. Using a flat blade screwdriver, press in the 2 tabs and open the bracket.

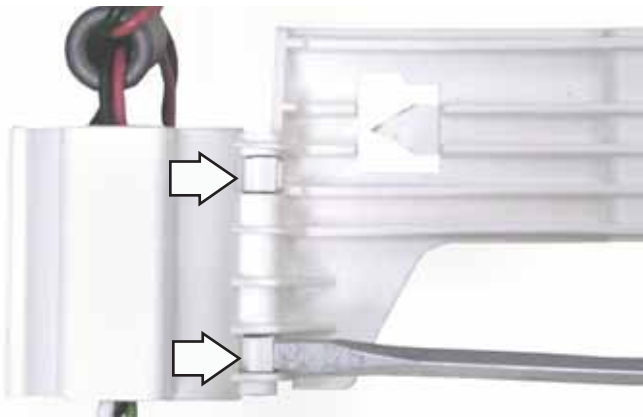

7. Disconnect the power cord wire harness.
8. Remove the 13 mm. hex nut and ground wire from the filter.

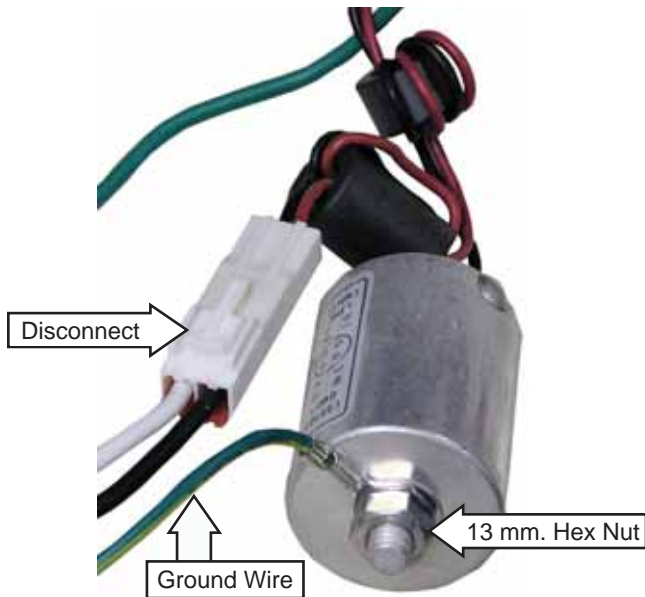

Compressor

The compressor is a reciprocating type. Refer to the mini-manual for the BTU/hour rating, refrigerant type, and correct charge for this model. A 1/4-in. O.D. copper tube is provided for access to the low pressure side of the refrigeration system.

PTCR Relay, Run Capacitor, and Overload Assembly

The PTCR relay, run capacitor, and overload assembly is held to the compressor by 2 legs at the bottom and a lock tab at the top.

To remove the PTCR relay, run capacitor, and overload assembly:

1. Remove the machine compartment cover. (See *Machine Compartment Cover*.)
2. Disconnect the PTCR relay, run capacitor, and overload wire harness.

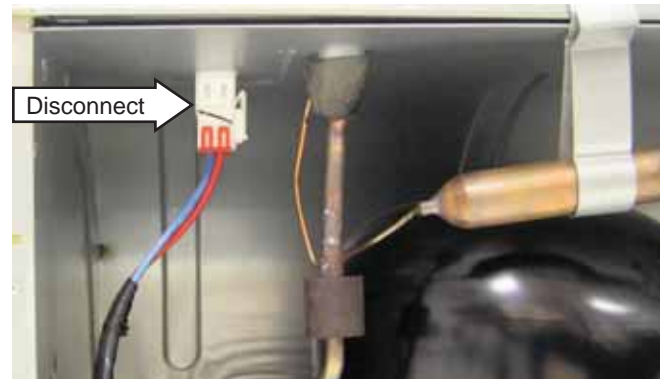

3. Using a flat blade screwdriver, press in the lock tab on top of the assembly and rotate the assembly counterclockwise.

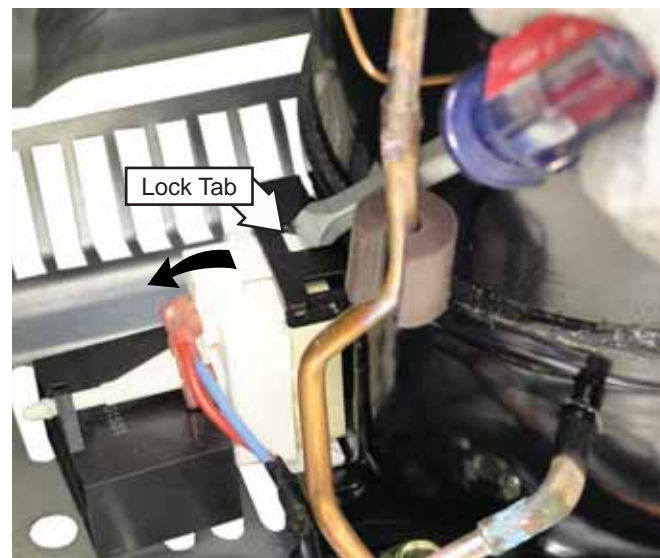

Dispenser Display Assembly

The dispenser display assembly incorporates the interface used for temperature control and features and houses the dispenser LED lights. The display has 6 tabs that hold it to the dispenser recess.

To remove the dispenser display:

1. Remove the Phillips-head screw from the housing.



2. Insert a small flat-blade screwdriver into the small opening located at the bottom front corner of the display.
3. Pry the bottom right side of the dispenser display away from the dispenser recess.



4. Grasp display, pull it towards the right and remove it from the recess.

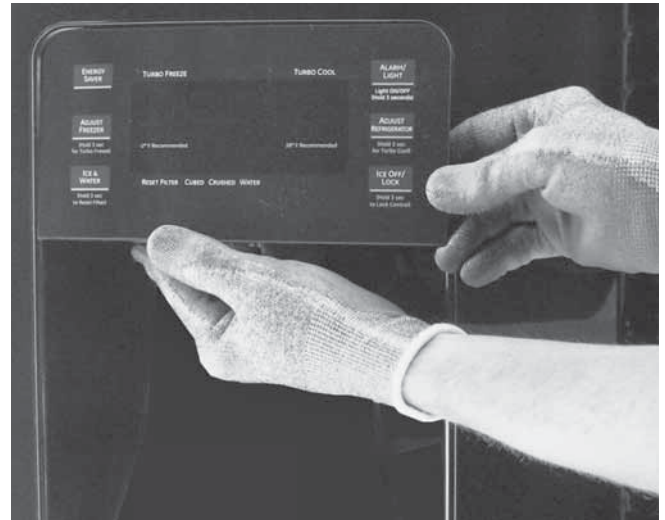

5. Disconnect the wire harness.

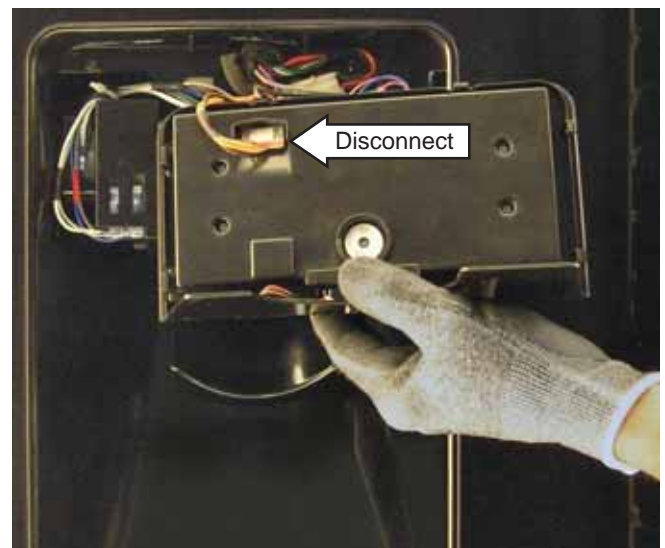

Caution: To prevent breaking tabs when installing the display, first insert the left side tabs into the recess then snap the display in place.

Dispenser Assembly

The dispenser assembly includes the duct door, duct door motor, cam and cam switches, and funnel. The assembly is held to the dispenser recess with 2 screws and 1 tab.

To replace the dispenser display:

1. Remove the dispenser display assembly. (See *Dispenser Display Assembly*.)
2. Disconnect the motor and cam switches wire harnesses.



3. Remove the 2 Phillips-head screws. Lower the assembly down to disengage the tab and pull the dispenser assembly from the recess.

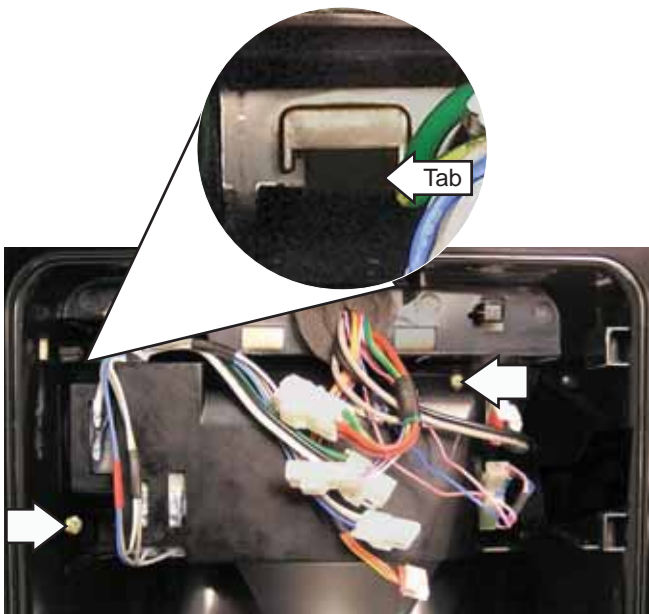

Caution: Wiring is firmly attached to the cradle switch. To prevent breaking mounting pins, care must be taken when removing wiring.

4. Carefully remove the cradle switch from the dispenser assembly.

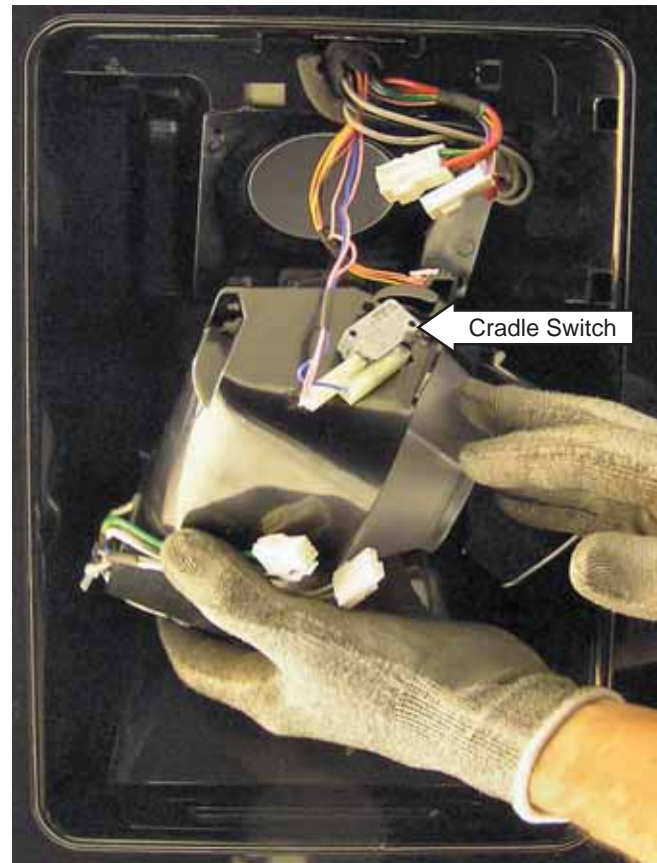

Note: When installing the dispenser assembly into the recess, ensure the water outlet is placed inside the funnel and tab is inserted into recess.

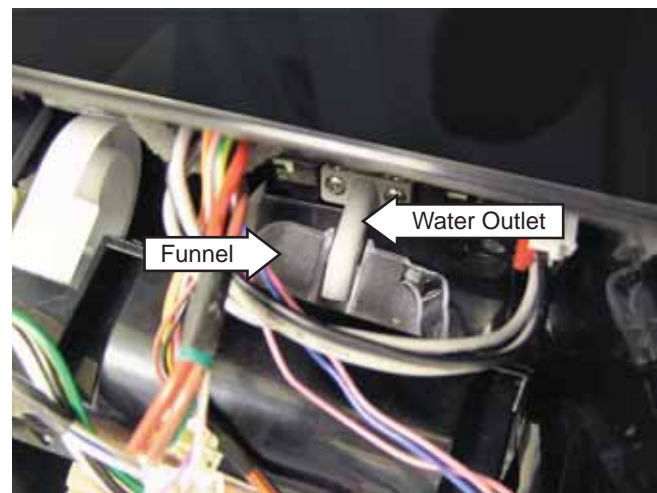

(Continued next page)

The duct door motor rotates an eccentrically shaped plastic cam which operates the duct door. The cam operates 2 route switches attached to the dispenser assembly. The switches inform the main board the position of the duct door so the auger and/or cube solenoid can be activated. If communication is lost between the switches and the board, because of a switch failure for example, the symptom usually will be continuous operation of the duct door.

The duct door motor operates at 120 VAC when energized by the main control board.

The motor has resistance value of approximately 1.79K Ω . Check for the approximate resistance value of the motor on the main board from CN70 pin 1 to CN73 pin 9.

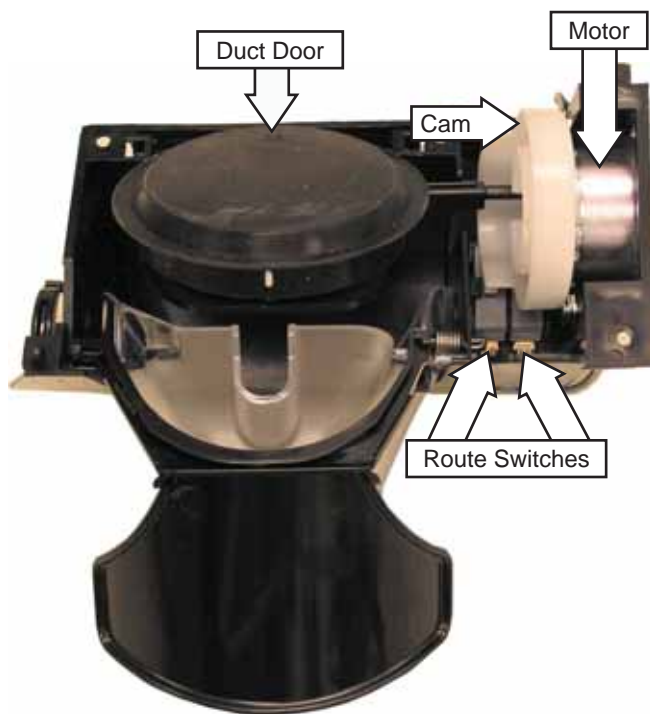

Dispenser Heater

The dispenser heater ensures that the dispensing recess does not sweat in high humidity. The dispenser heater operates at 120 VAC when energized by the main control board.

The heater has resistance value of approximately 4.4K Ω . Check for the approximate resistance value of the heater on the main board from CN70 pin 3 to CN1 pin 3.

Note: The dispenser heater is integral to the foamed in place dispenser recess in the left-side refrigerator door and is not replaceable.

Vegetable and Fruit Drawers Shelf

To remove the vegetable and fruit drawers shelf:

1. Pull the 2 fruit and vegetable drawers out to the stop position. Lift and remove the drawers.
2. Lift and pull out the shelf.

Pantry Drawer Assembly

To remove the pantry drawer assembly:

1. Pull the 2 fruit and vegetable drawers out to the stop position. Lift and remove the drawers.
2. Pull the pantry drawer out to the stop position. Lift and remove the drawer.
3. Carefully lift the center of the drawer cover up while pushing the cover to the left. When the right side hinge pin has disengaged from the hole in the rail assembly, slide the right side of the cover out.

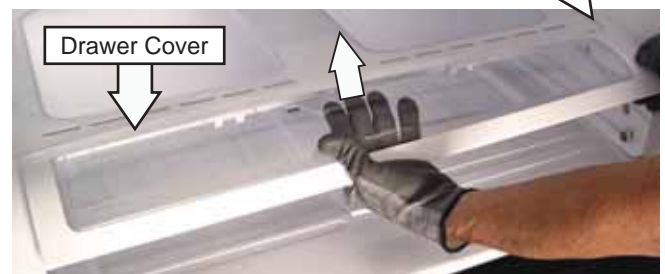
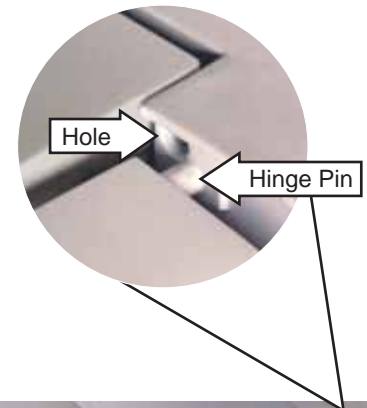

4. Lift and pull out the drawer cover.
5. Lift the front of the pantry shelf and pull it out of the refrigerator.

Pantry Drawer Control

To remove the pantry drawer control:

1. Remove the pantry drawer assembly. (See *Pantry Drawer Assembly*.)
2. Remove the 3 Phillips-head screws that attach each rail.

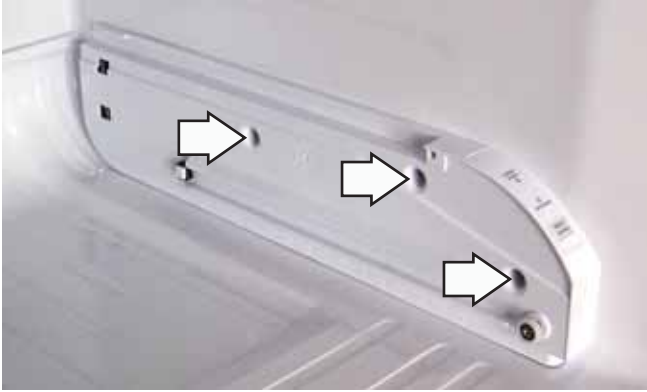

3. Pull the rail towards the front of the refrigerator.
4. Disconnect the wire harness from the right side rail.
5. Remove the Phillips-head screw that attaches the control to the rail.

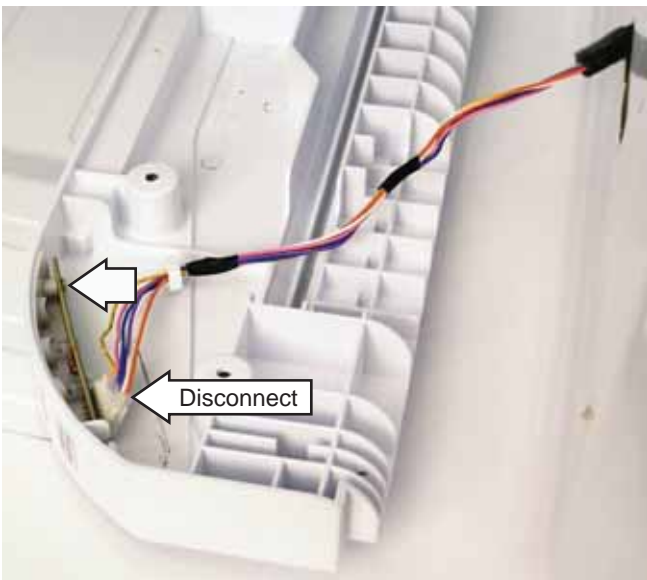

Damper Assembly

The damper assembly is held to the back wall of the refrigerator with a Phillips-head screw and 2 tabs.

To remove the damper motor:

1. Remove the pantry drawer. (See *Pantry Drawer Assembly*, follow steps 1 and 2.)
2. Remove the recessed Phillips-head screw from the damper cover.



3. Pull the bottom of the damper cover out and down from the back wall of the refrigerator.
4. Disconnect the 2 wire harnesses.

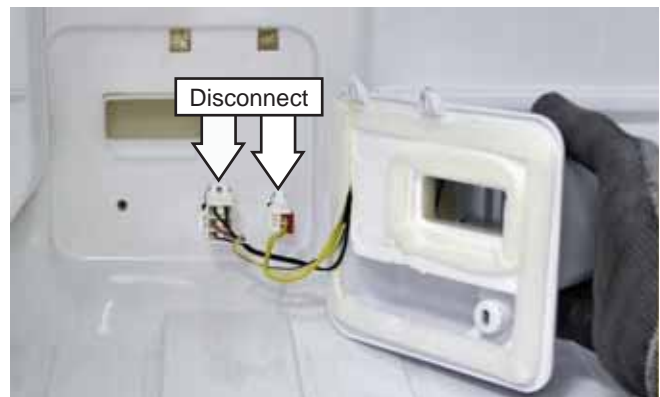

Water Tank

To remove the water tank:

1. Remove the vegetable and fruit drawers shelf. (See *Vegetable and Fruit Drawers Shelf*.)
2. Remove the pantry drawer. (See *Pantry Drawer*.)
3. Remove the 2 Phillips-head screws that attach the water tank assembly to the back wall of the refrigerator section.

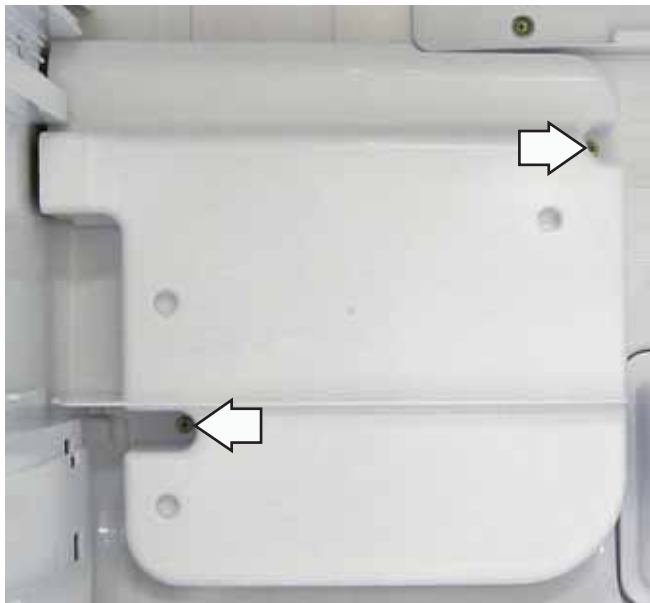

4. Carefully pull the right side of the tank assembly approximately 5 inches out from the back wall.
5. Disconnect the water tank heater wire harness.



Note: The water tank heater is attached to the tank cover with a recessed Phillips-head screw and held to the water tank by a tab.

6. Remove the Phillips-head screw that attaches the water tank heater to the cover.
7. Pull out the tank heater to disengage the tab.

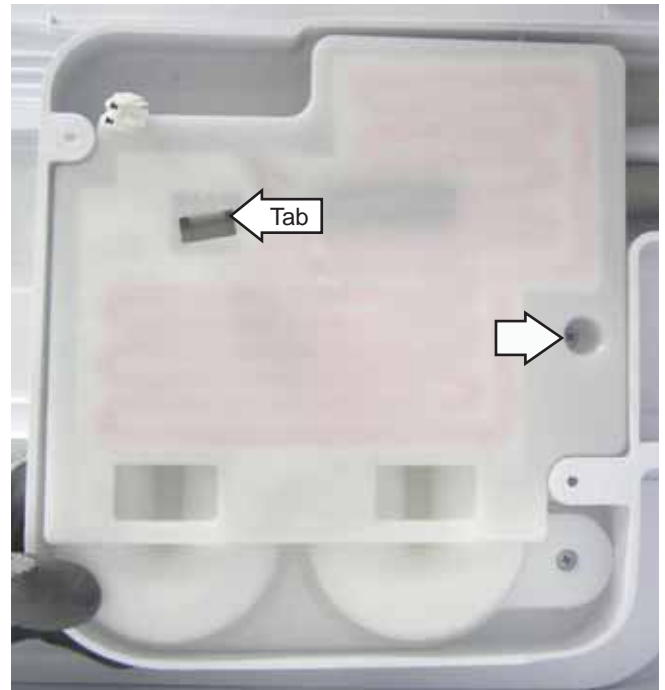

8. Remove the 2 Phillips-head screws that attach the water tank to the cover.

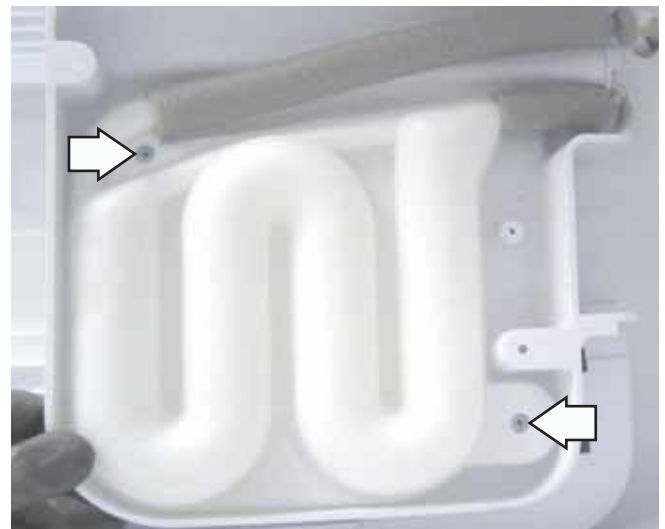

(Continued next page)

Note: The water tank and the tank inlet and outlet tubes are replaced as an assembly. The tank inlet and outlet tubes are routed through separate conduits placed inside the cabinet wall.

- 9. Place the top table upsidedown on top of the cabinet. (See *Top Table*.)
- 10. Push in the rear collar on the water coupling then pull out the water tube.

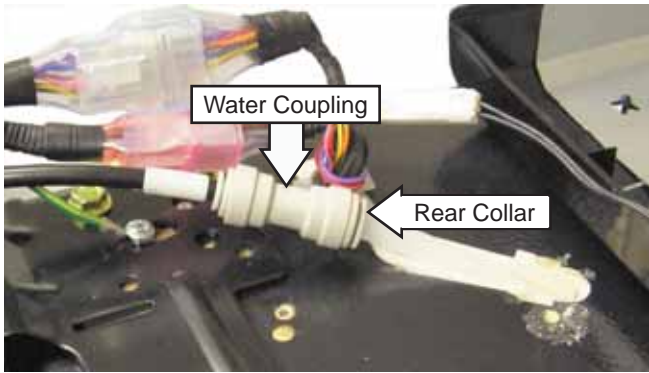

- 13. Push in the collar on the dispenser side of the valve then pull out the water tube from the valve assembly.

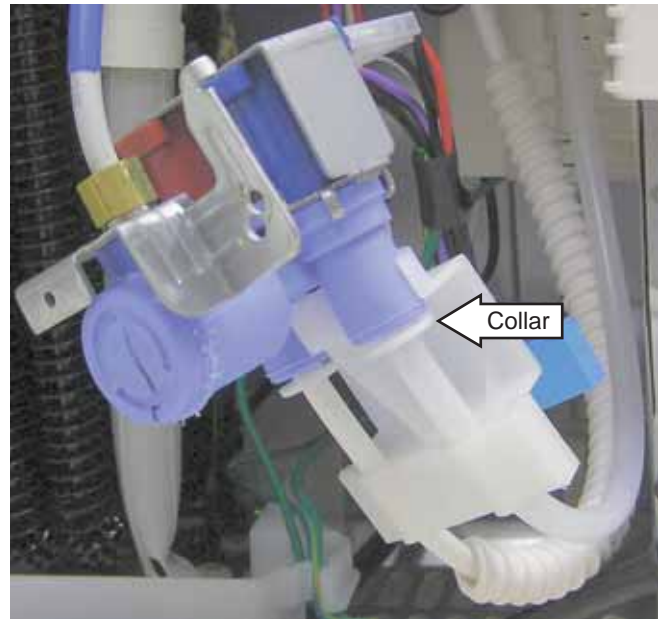

- 11. Remove the machine compartment cover. (See *Machine Compartment Cover*.)
- 12. Remove the Phillips-head screw that holds the water valve in place.

- 14. Carefully pull out the water tank and remove the tubing from the conduits.

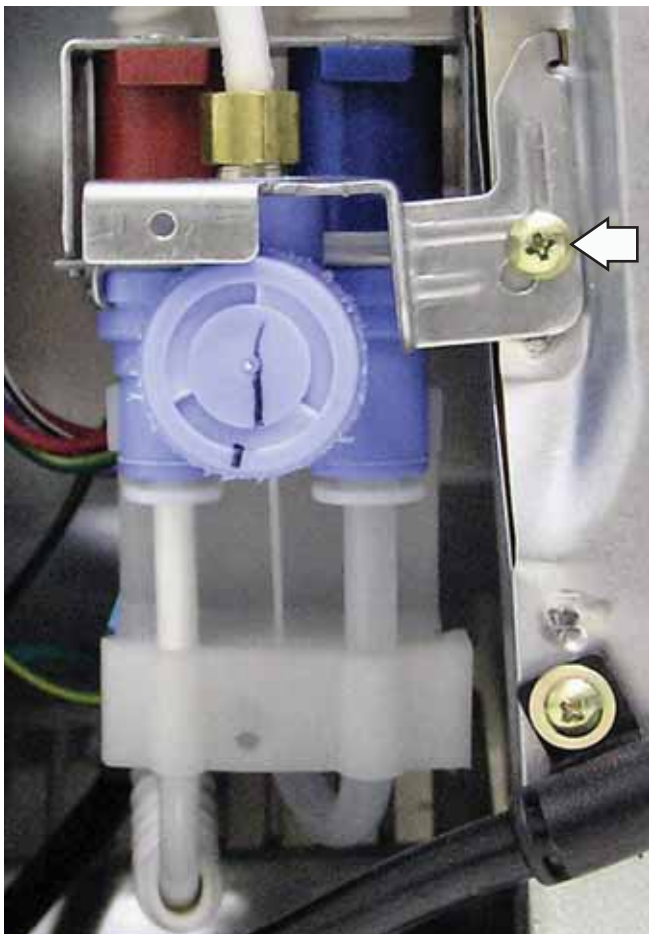

Note: Arrows moulded on the water tank show water flow direction. When installing the water tank tubing into the cabinet conduits, insert the inlet tube in the top conduit and the outlet tube into the bottom conduit.



Ice Bucket and Icemaker

Ice Bucket

The bucket can be removed by pulling the release lever towards the front of the refrigerator and sliding the bucket out.



Icemaker

Under normal operating conditions, the icemaker is capable of producing approximately 100-130 cubes (approximately 4.3 pounds of ice) in a 24-hour period. The rate of ice production depends on freezer compartment temperature, room temperature, number of door/drawer openings, and other use conditions.

To activate the icemaker cycle, press and hold the start button approximately 3 seconds.

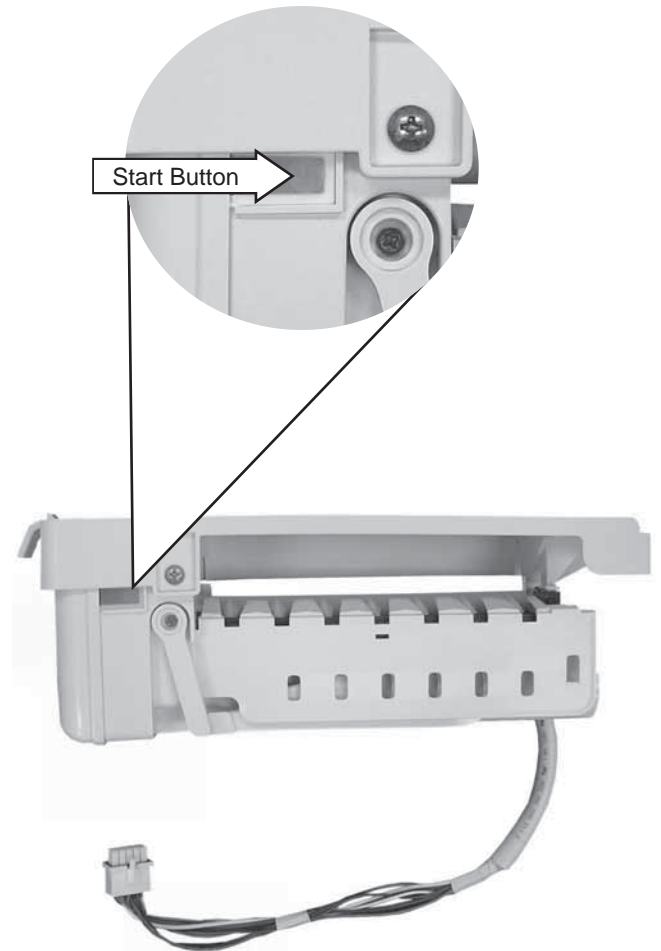

The icemaker is attached to the ceiling of the iceroom by 2 key tabs.

To remove the icemaker:

1. Remove the Ice bucket. (See *Ice Bucket*.)
2. Remove the Phillips-head screw that attaches the front of the wire harness cover.



3. Using a small flat blade screwdriver, pry the front of the cover out, then pull the cover towards the front of the refrigerator.



4. Note the routing of the icemaker wire harness, then disconnect the harness.

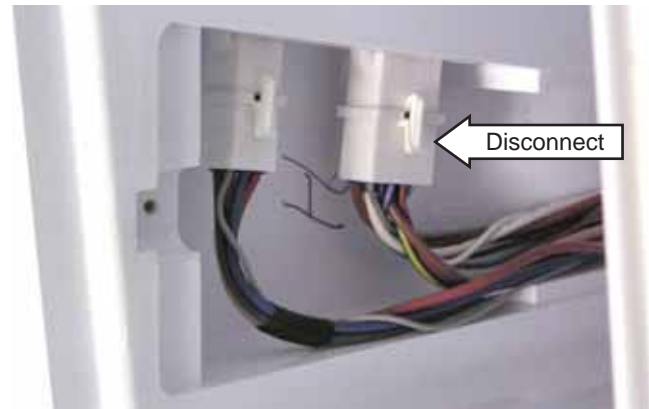

5. Push in the release tab on the front of the icemaker, then pull the icemaker out of the ice room.



Note: When installing icemaker, engage key slots in key tabs before pushing icemaker in place.

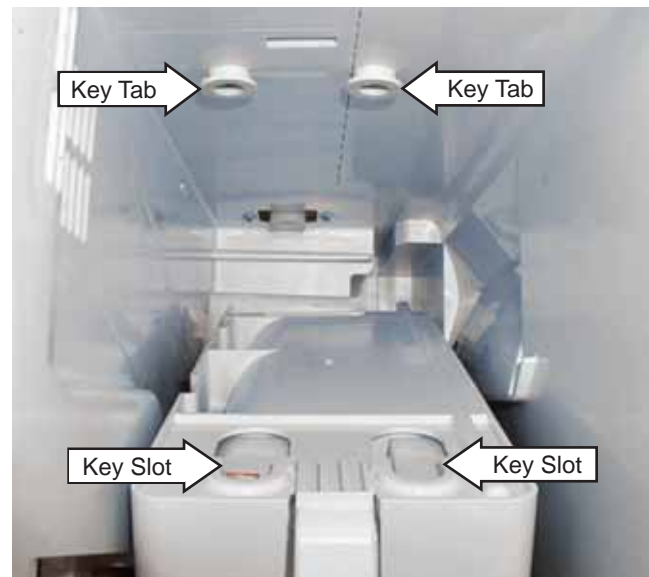

Auger Motor Assembly

To remove the auger motor assembly:

1. Remove the ice bucket and icemaker. (See *Ice Bucket and Icemaker*.)
2. Note the routing of the auger motor assembly wire harness, then disconnect the harness.

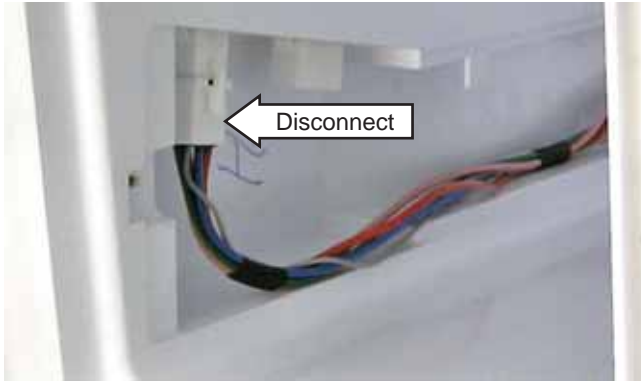

3. Push the release tab on the front of the auger motor assembly to the right, then pull the auger motor assembly out of the iceroom.

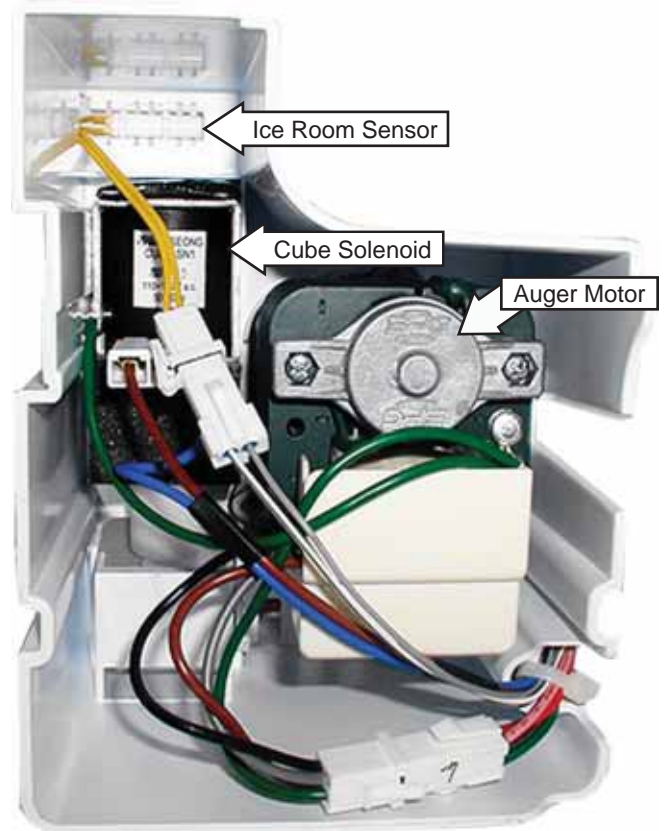

Auger Assembly Components

Fresh Food Door Switch

Note: On early production models, the black wire is not connected to any circuit. It was added to protect the exposed unused terminal.

On later production models, the separate wiring will be changed to a plug-in harness and the black wire will be removed.

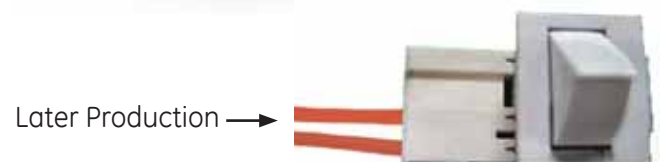
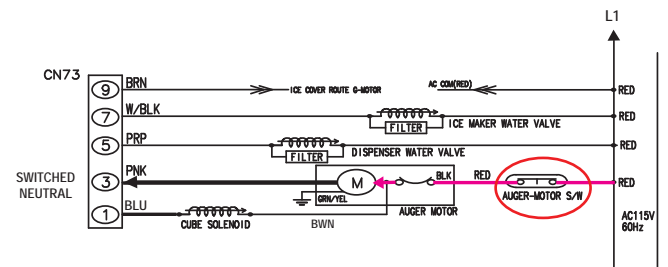

Articulating Door Mullion

The articulating door mullion is attached to the left side door, and provides a movable center mullion that maximizes access to the fresh food compartment. With both refrigerator doors closed or only the right side door opened, the mullion stays in position. When the left side door is opened, the spring-loaded mullion is activated to fold against the handle side of the door liner.

The pin on top of the mullion and the track, located at the top center front of the refrigerator, ensures proper mullion bar alignment upon closure of the left side door.

The articulating door mullion consists of the mullion, heater, external spring, and 3 hinges.

Note: If the Energy Saver indicator light is lit, then the articulating door mullion heater is disabled.

The heater operates on 120 VAC with the doors open or closed. The resistance of the heater is approximately 1.3K Ω . Check for the correct voltage and resistance on the main board at CN71 pin 5 to CN1 pin 3.

To remove the articulating door mullion assembly:

1. Using a small flat blade screwdriver, pry off the 2 screw caps.

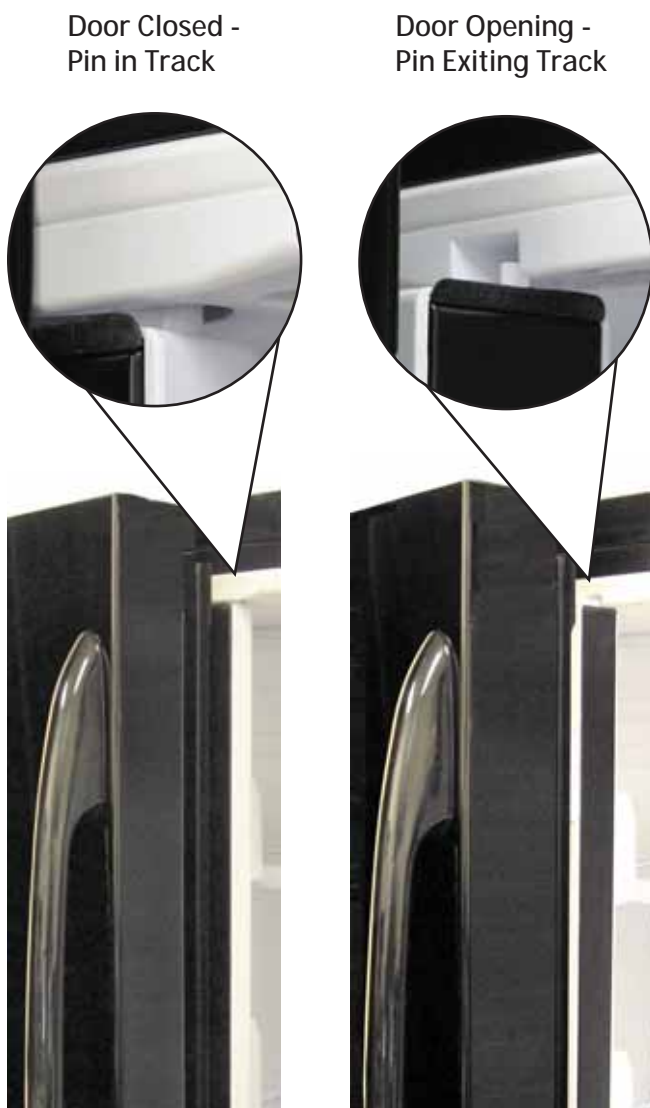

2. Remove the 2 Phillips-head screws from the wire harness cover.

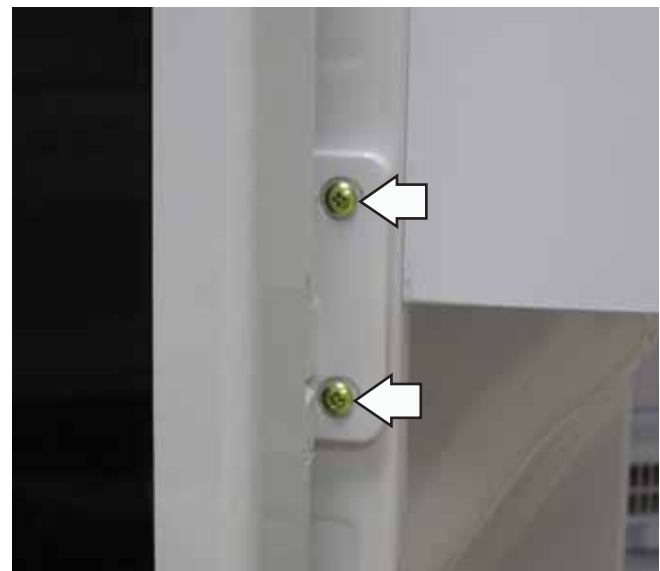

3. Grasp the mullion and pull it vertically upward to release it from the top and bottom retainers.



4. Pull out and disconnect the wire harness.



To disassemble the mullion assembly:

1. Remove the articulating door mullion assembly. (See *To remove the articulating door mullion assembly*.)

Caution: In the following step, care must be taken to prevent breakage of the door closure cover and/or door closure hinge.

2. Remove the door closure spring by pulling the top arm of the spring down and out of the door closure cover.
3. Lift the spring out of the door closure hinge.

Note: Be sure the spring sleeve is placed in the door closure cover before installing spring.

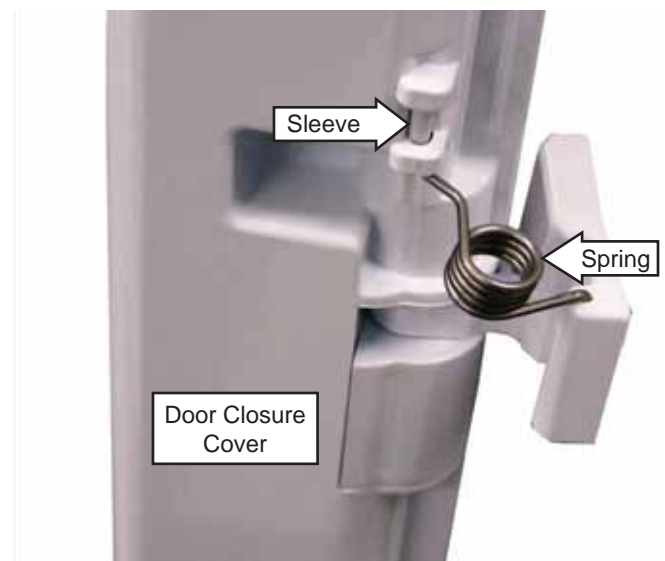

Note: The door closure support is held to the door closure cover with 13 tabs.

4. Using a putty knife or similar tool, carefully pry and lift the door closure support from the door closure cover.

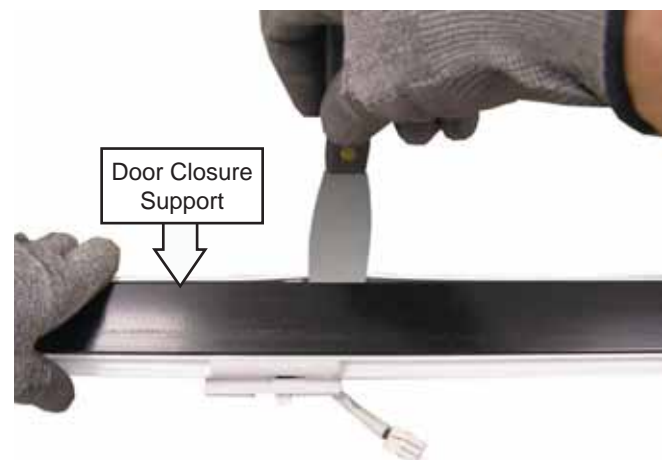

(Continued next page)

5. Using a putty knife or similar tool, carefully pry and lift the door closure case from the door closure cover.



8. Remove the door closure heater wire harness from the wire harness cover and the door closure cover.

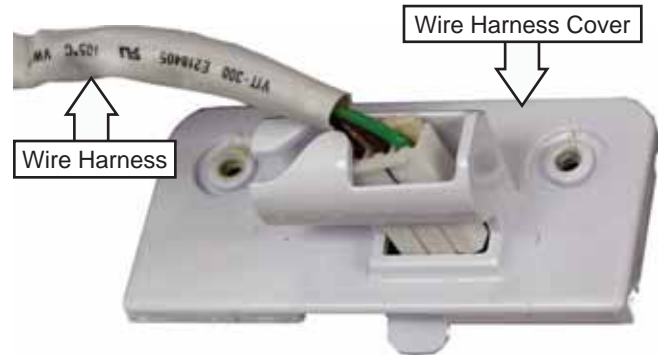

Note: There is a closure gasket attached to each end of the door closure support. Each gasket has 2 pins that pull through 2 holes in each end of the door closure support.

6. Remove the Phillips-head screw that attaches the center hinge cap to the door closure cover.



7. Using a small flat blade screwdriver, pry out the center hinge cap.

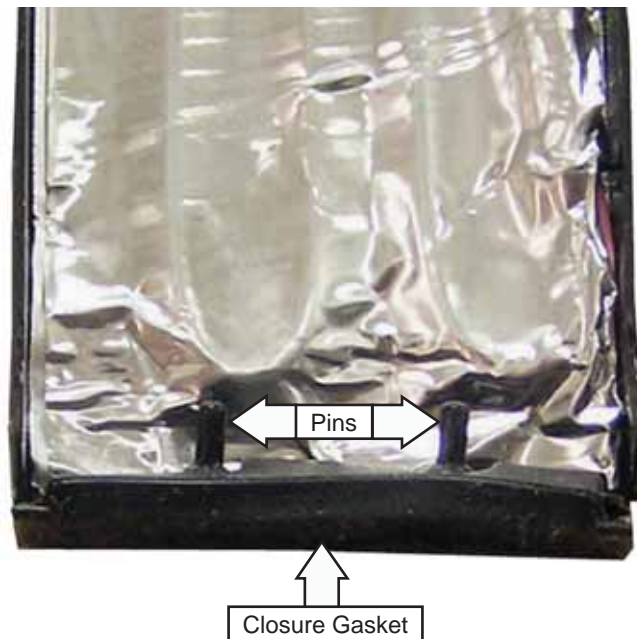

Note: In the following step, the ground wire connector utilizes a release/locking tab.

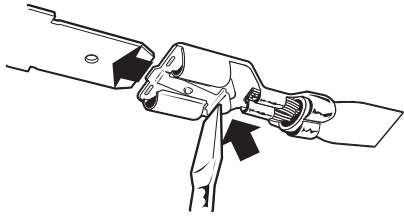

ELECTRICAL TERMINAL
RELEASE/LOCKING TAB

9. Disconnect the heater ground wire from the door closure support.
10. Peel the door closure heater from the door closure support.

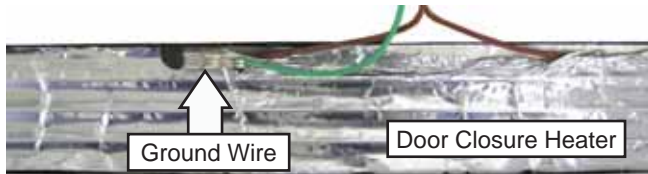

11. Using a flat blade screwdriver, pry and push the tab that holds the bottom and top hinge caps to the door closure cover.



Circuit Boards

The main control, power supply, and fresh food LED light boards are installed in a recess located in the back of the refrigerator. The recess is concealed by a cover that is attached with 2 tabs at the bottom (not visible) and 2 Phillips-head screws at the top.

To access the boards, it is necessary to remove the 2 Phillips-head screws then lift the cover from the back of the refrigerator.



Main Control Board

The main control board is positioned behind 2 tabs at the bottom and attached to the recess with a Phillips-head screw and a lock tab at the top. The board is connected to the refrigerator with 13 wire harnesses. To remove the board, it is necessary to disconnect the wire harnesses, remove the Phillips-head screw, and push up the lock tab.

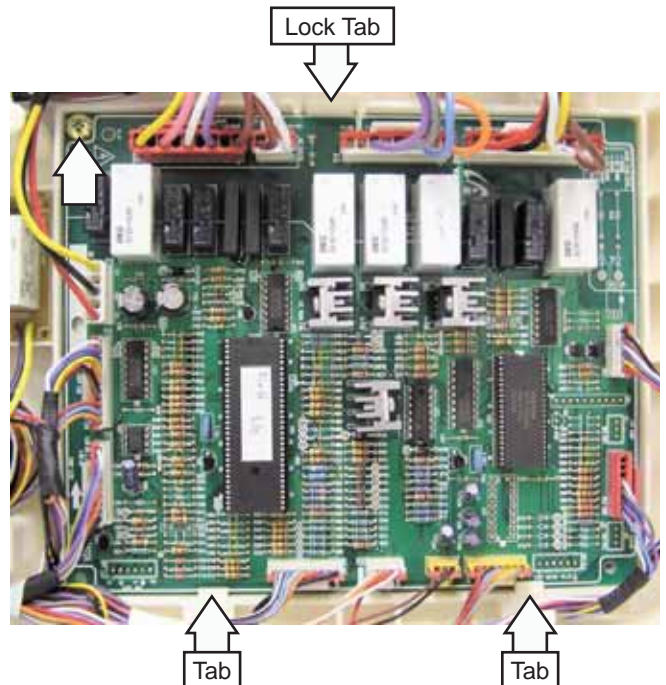

(Continued next page)

Power Supply Board

The power supply board is positioned behind 2 tabs at the top and attached to the recess with a lock tab at the bottom. The board is connected to the refrigerator with 2 wire harnesses. To remove the board, it is necessary to disconnect the wire harnesses, and push down the lock tab.

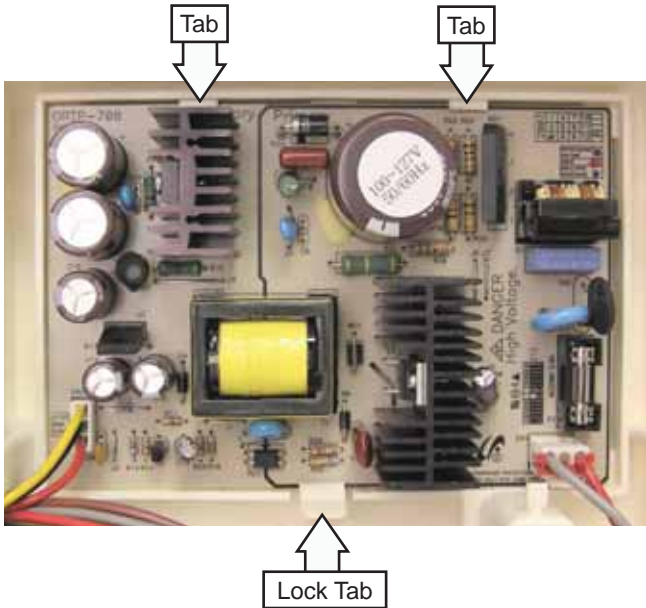

Fresh Food LED Light Board

The fresh food LED light board is positioned behind a tab at the bottom and attached to the recess with a lock tab at the top. The board is connected to the refrigerator with 2 wire harnesses. To remove the board, it is necessary to disconnect the wire harnesses, and push up the lock tab.

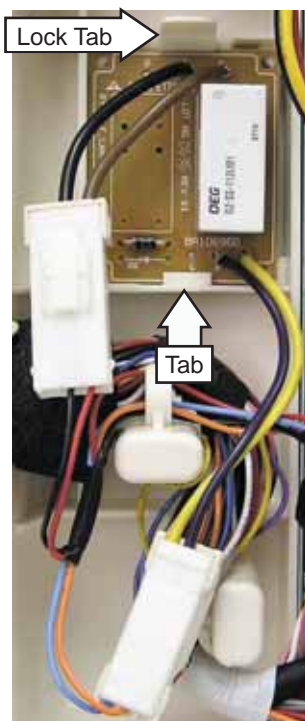

Control Panel Operation

Showroom Mode

Note: There is no off mode that can be accessed using the display.

To enter the showroom mode, press ENERGY SAVER and ADJUST FREEZER pads simultaneously for 3 seconds. OF - OF will be displayed. The lights and fans (if previously operating) will still operate but the compressor will not operate. To return to normal operation, press ENERGY SAVER and ADJUST FREEZER pads simultaneously for 3 seconds. Unplugging the refrigerator does not escape showroom mode.

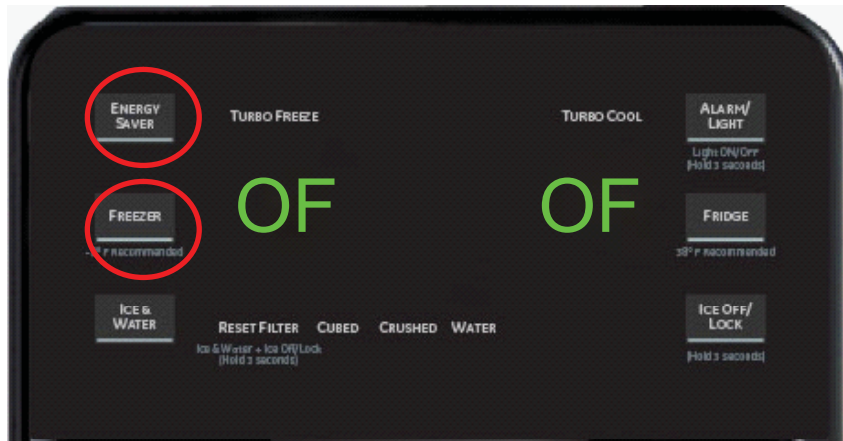

Temperature Adjustment

The temperature controls are preset in the factory at 38°F (3.3°C) for the refrigerator compartment and -2°F (-18.9°C) for the freezer compartment. The refrigerator compartment can be set anywhere between 34°F (1.1°C) and 46°F (7.7°C). The freezer compartment can be set anywhere between -14°F (-25.5°C) and 8°F (-13.3°C). Press and release ADJUST FREEZER or ADJUST REFRIGERATOR pads continuously until the desired temperature is displayed.

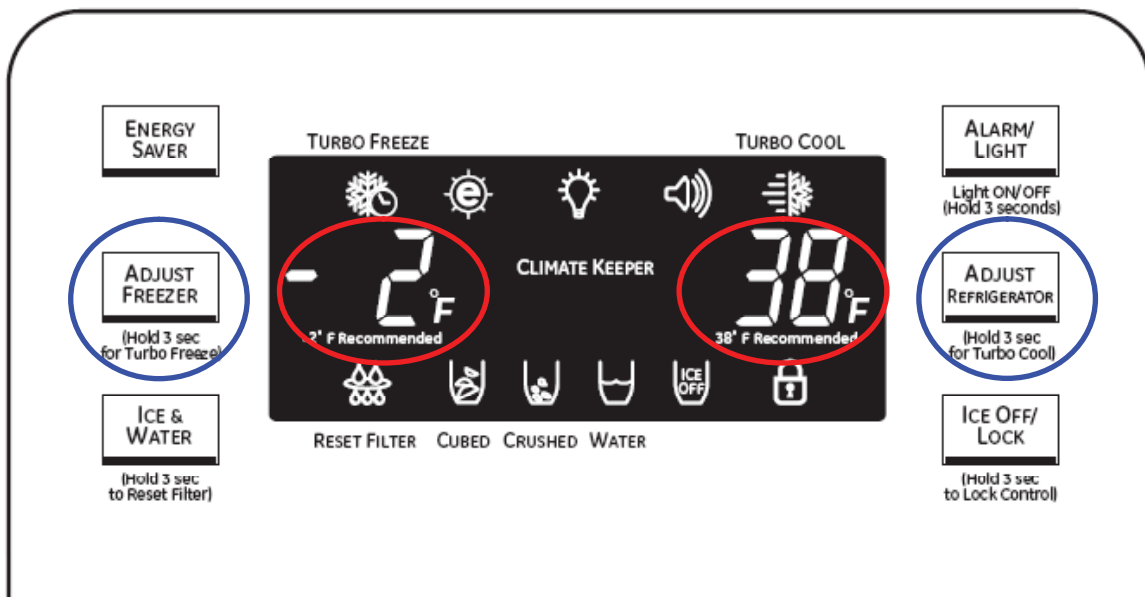

Energy Saver

Press ENERGY SAVER to turn the articulating mullion heater on or off.

Alarm/Light

When selected to the on mode, the door alarm will sound an alarm if a refrigerator door or the freezer drawer is open for more than 3 minutes. Pressing the ALARM/LIGHT pad for 3 seconds turns the dispenser lights on or off.

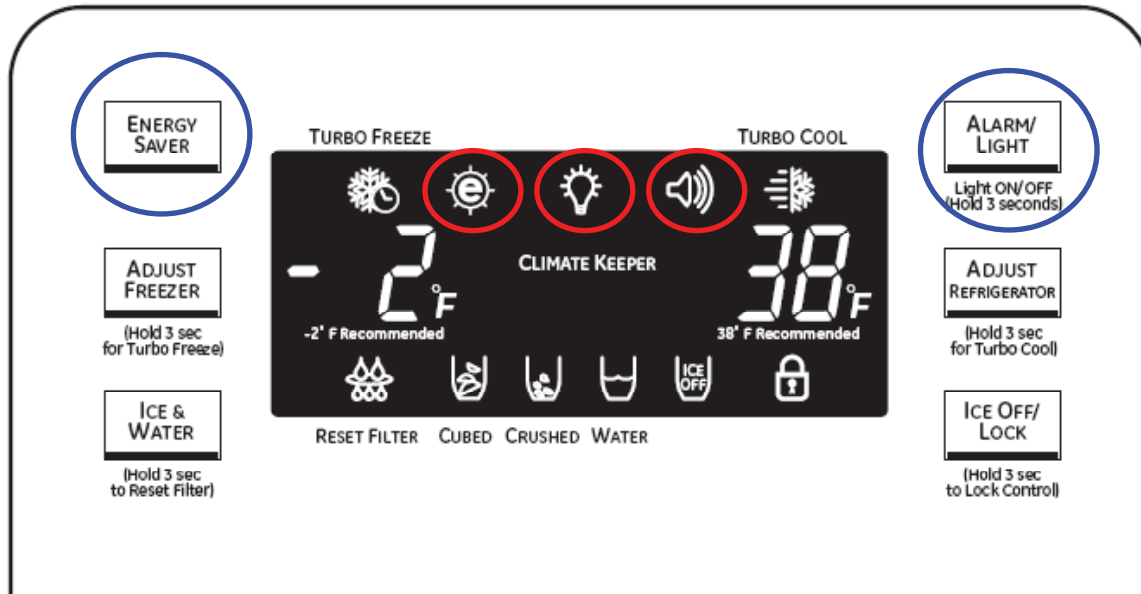

Turbo Freeze and Turbo Cool

Note: Select Turbo Freeze or Turbo Cool separately. When Turbo Freeze or Turbo Cool is selected, the set temperatures in the freezer and refrigerator are not changed. The set temperatures for the compartments can be changed while these functions are in use.

Turbo Freeze Function

To select or cancel Turbo Freeze, press and hold the ADJUST FREEZER pad for 3 seconds.

When you select Turbo Freeze, the LED indicator is displayed immediately, but there is 10 seconds lag time to engage the actual operation. When Turbo Freeze is cancelled, the Turbo Freeze function stops and the indicator turns off immediately. When selected, both the compressor and the freezer fan run for 2.5 hours continuously. After 2.5 hours has elapsed or if Turbo Freeze has been cancelled, the indicator goes off and the freezer set temperature will be restored.

Turbo Cool Function

To select or cancel Turbo Cool, press and hold the ADJUST REFRIGERATOR pad for 3 seconds. The operation of Turbo Cool is the same as Turbo Freeze with the following exception: When Turbo Cool is selected, the compressor and refrigerator fan will operate until the refrigerator temp reaches 25°F (-3.9°C), or if 2½ hours expires. At this point, the cycle will be terminated.

Note

- When Turbo Freeze and Turbo Cool are selected to operate at the same time, the compressor and freezer fan run continuously and the refrigerator fan runs until 25°F (-3.9°C) is reached in the refrigerator.
- If Turbo Freeze is selected when the freezer and the refrigerator temperatures are higher than 14°F (-10°C) and 50°F (10°C), respectively, the refrigerator fan will be off. If Turbo Cool is selected, then the freezer fan will be off. When both functions are selected, there is no benefit of fast cooling for either compartment.

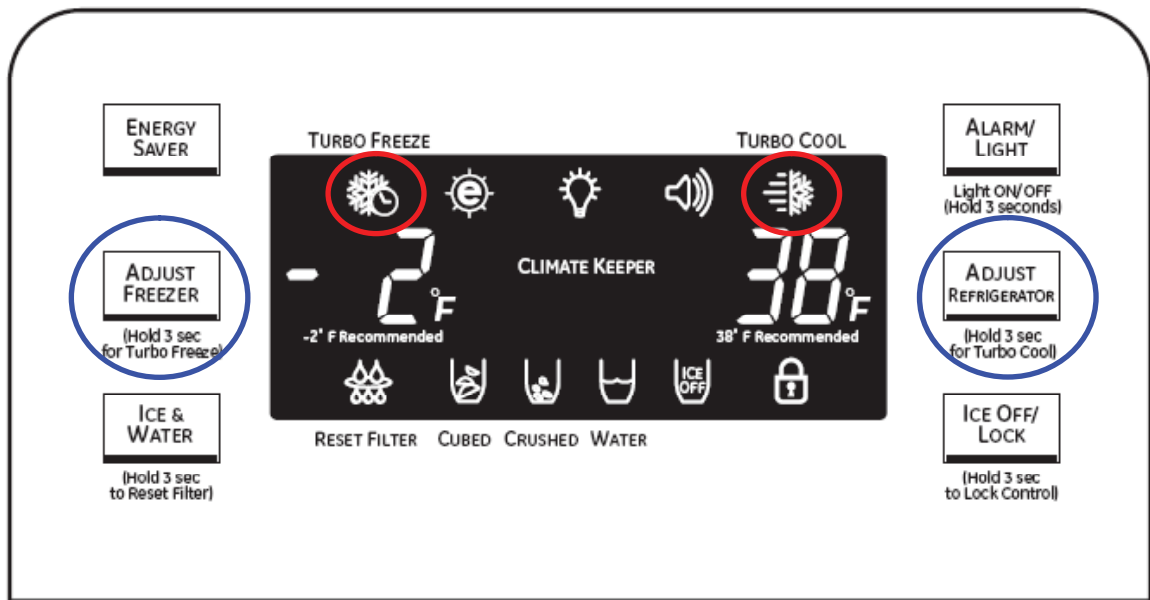

Ice & Water

To select cubed ice, crushed ice, or water, press the ICE & WATER pad. Repeated pressing of the pad will toggle between cubed ice, crushed ice and water.

Filter Reset Function

To reset the water filter indicator, press and hold the ICE & WATER pad for 3 seconds.

Note

The reset filter indicator will always be illuminated. If the filter is OK, the color is green. As the filter becomes restricted the indicator will turn yellow. A red color indicates the filter needs to be replaced. Resetting the filter indicator will turn the indicator back to green.

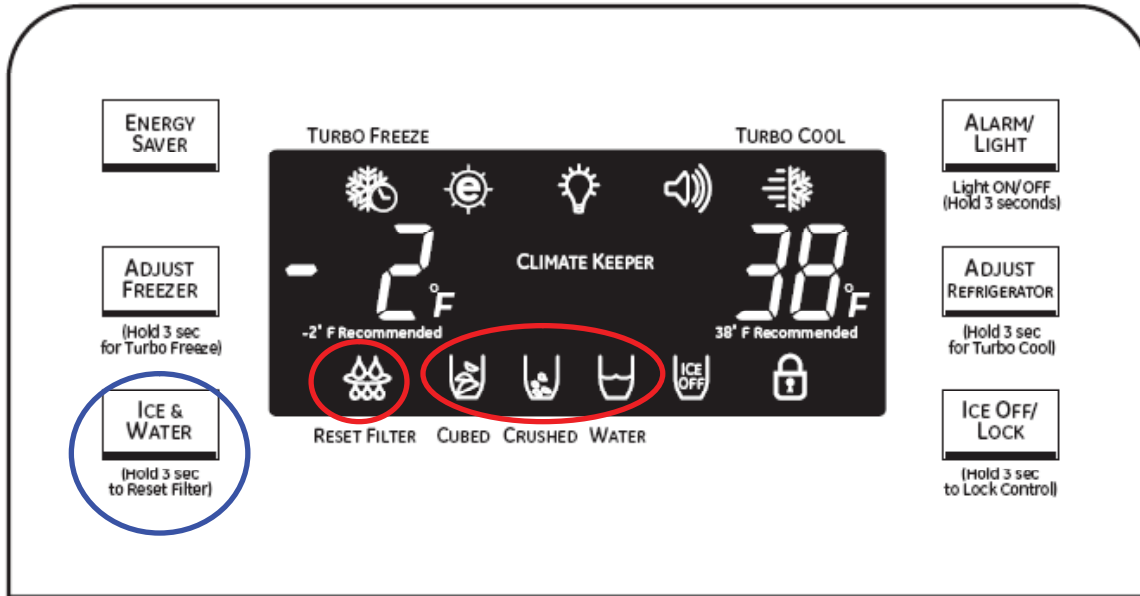

Ice Off/Lock

To turn off the ice maker, press the ICE OFF/LOCK pad.

To lock the control panel and dispenser, press and hold the ICE OFF/LOCK pad for 3 seconds.

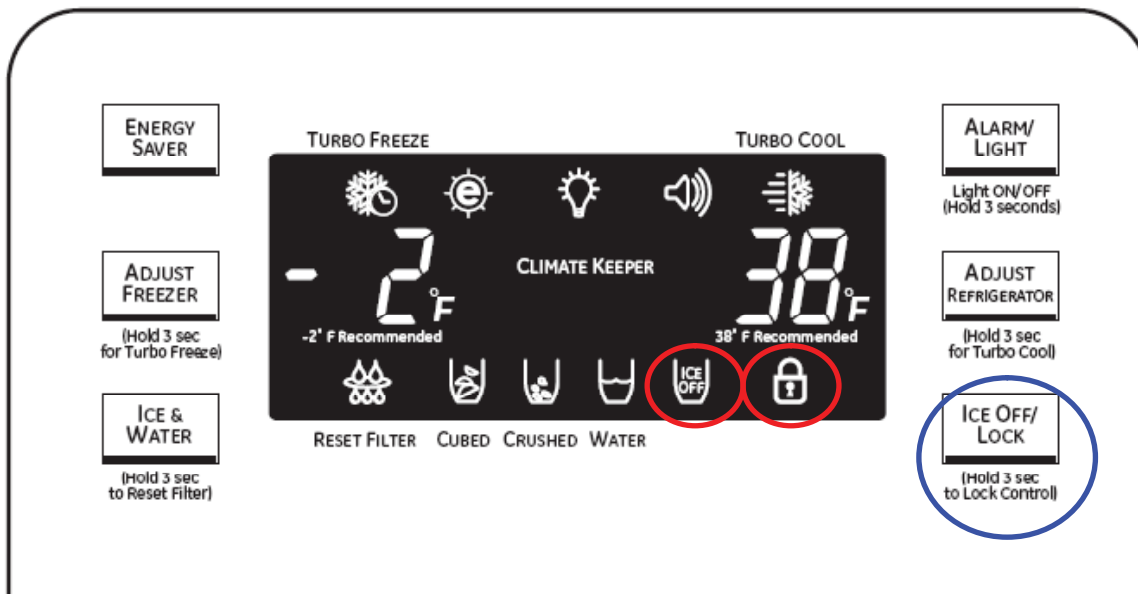

Troubleshooting

Test Mode Operation

Test Mode – Manual Operation/Manual Defrost

To enter the test mode, press ENERGY SAVER and ADJUST REFRIGERATOR pads simultaneously for 8 seconds. The display panel will go blank. Press any pad within 15 seconds to initiate test mode.

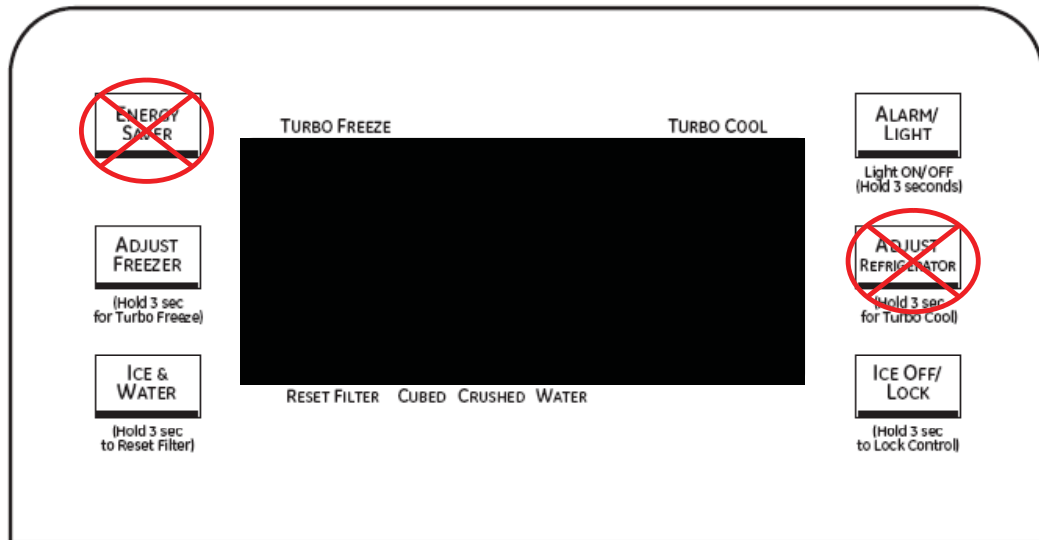

If any pad is pressed within 15 seconds it will generate the following sequence:

1st press - Manual operation – Compressor and Fans (FF) Displayed

2nd press - Manual Defrost – Fresh Food Compartment (rd) Displayed

3rd press - Manual Defrost – FF and Frz Compartments (Fd) Displayed

4th press - Cancel – (Display Off) Normal Operation is restored after approximately 10 seconds.

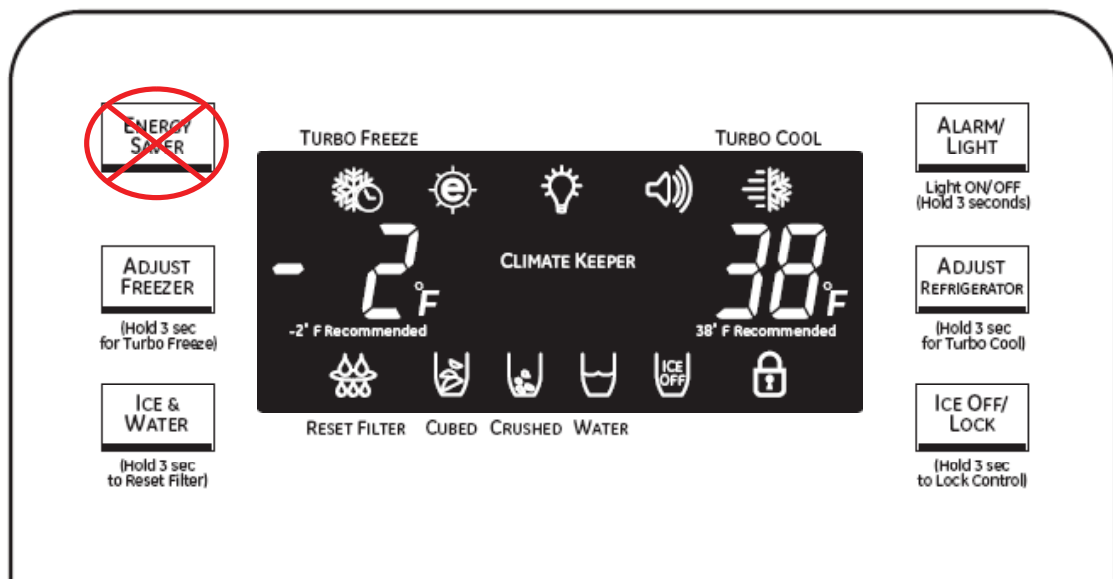

Note: Test mode can also be canceled by removing power and then powering unit back up.

Display Function – Communication Errors

If there is no communication for 10 seconds after request between the control panel and the main board, the display will flash Pc Er until the communication error is corrected. The refrigerator will continue to operate normally. A flashing Pc Er can be caused by a communication circuit failure on the main board and/or the control panel board, or a loose connection.

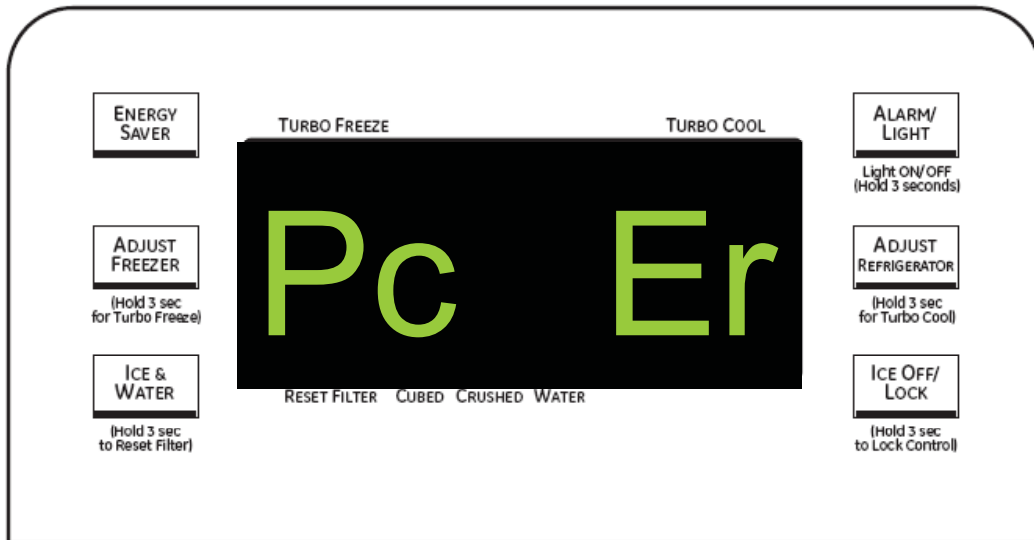

If there is no communication for 20 seconds after request between the integrated circuits (IC Chips) on the main board, the display will flash Lc Er until the communication error is corrected. The pantry room control will also flash until the communication error is corrected. The refrigerator will continue to operate normally. A flashing Lc Er is caused by a communication circuit failure on the main board.

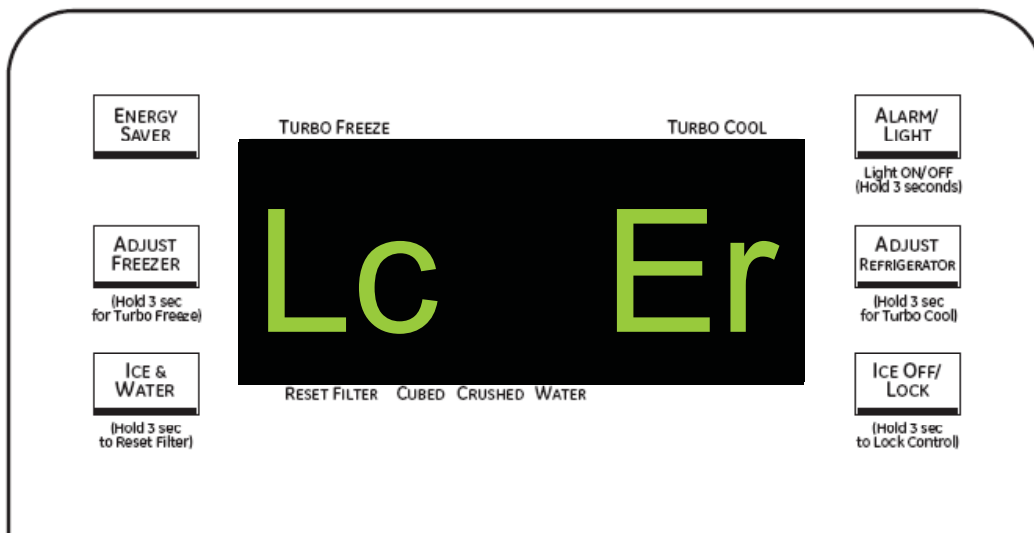

Failure and Load Condition Displays

The display can utilize individual segments of a particular figure "8" that will flash to indicate failure or load conditions.

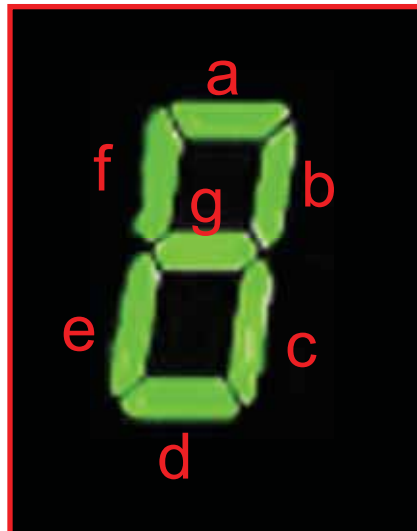
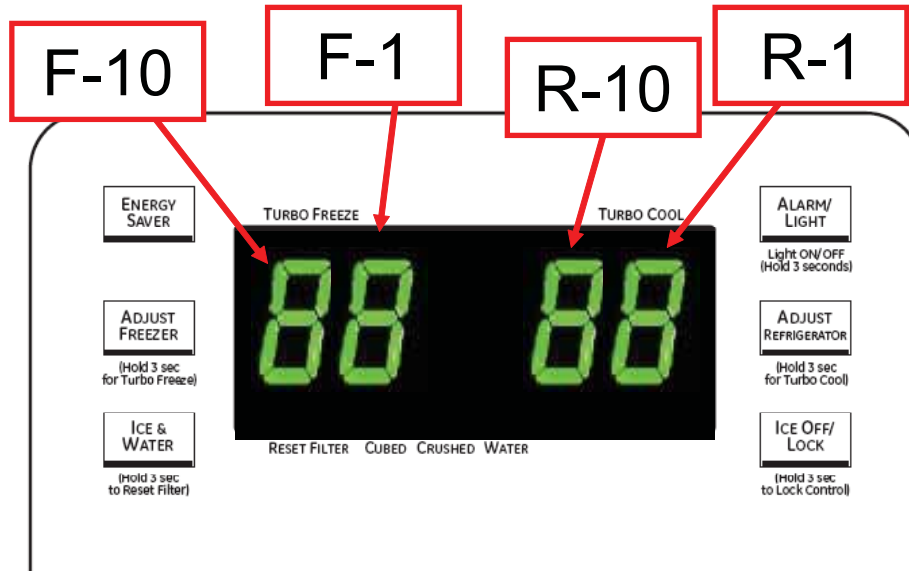

Failure Conditions – Initial Power Up

Upon initial power up, if certain failed components have been detected, individual segments of a particular figure “8” will flash to indicate the failed components.



To return the display to normal, simultaneously press the ENERGY SAVER and ALARM/LIGHT pads for 8 seconds.

Note: The failure condition will still exist when returning the display to normal. For proper operation of the refrigerator, correct or replace the faulty component.



Failure Condition Display Code Table

NO	Trouble Item	Display LED	Trouble Contents
1	Icemaker Sensor Error	R-1- (a)	Icemaker Sensor part error
2	Refrigerator Sensor Error	R-1- (b)	Refrigerator Sensor part error
3	Refrigerator Defrost Sensor Error	R-1- (c)	Refrigerator Defrost Sensor part error
4	Refrigerator Fan Error	R-1- (d)	Refrigerator inner part error
5	Icemaker error	R-1- (e)	Icemaker operation error
6	Refrigerator Defrost Heater Error	R-1- (g)	Refrigerator defrost part error
7	Ambient Sensor Error	F-1- (a)	External Sensor part error
8	Freezer Sensor Error	F-1- (b)	Freezer Sensor part error
9	Freezer Defrost Sensor Error	F-1- (c)	Freezer Defrost Sensor part error
10	Freezer Fan Error	F-1- (d)	Freezer inner fan motor part error
11	Condenser Fan Error	F-1- (e)	Machine room fan motor part error
12	Ice Room Sensor Error	F-1- (f)	Ice Room Sensor part error
13	Freezer Defrost Heater Error	F-1- (g)	Freezer Defrost part error
14	Ice Room Fan Error	F-10- (b)	Ice Room inner fan motor part error
15	Pantry Damper Heater Error	R-10- (a)	Damper Heater open/wire error
16	Pantry Sensor Error	R-10- (b)	Pantry Room Sensor part error
17	Panel-Main Micom Error	F-10- (g)	Panel-Main Micom communication error
18	L-M Communication Error	F-10- (f)	LOAD-Main Micom communication error
19	Water Tank Heater Error	R-10- (g)	Water Tank Heater open/wire error

Load Condition Displays

To access the load condition display, press ENERGY SAVER and ALARM/LIGHT pads simultaneously for 6 seconds. The display will beep and start to flash. Immediately remove fingers from previous pads and press the adjust Refrigerator pad. The load condition mode will then be energized.



Segments of the figure "8"s will blink on and off corresponding to the loads that the main board has energized.

Note: Just because the board has a load energized, does not mean that the component is functioning.



Load Condition Display Code Table

Display LED	Display Contents	Operation Contents
R-1- (a)	Refrigerator Fan High	When fresh food compartment fan high operates, applicable LED ON
R-1- (b)	Refrigerator Fan Low	When fresh food compartment fan low operates, applicable LED ON
R-1- (c)	Refrigerator Defrost Heater	When fresh food compartment defrost heater operates, applicable LED ON
R-1- (d)	Start Mode	Initial power ON refrigerator, applicable LED ON
R-1- (e)	Overload Condition	When ambient temperature is more than 93°F (34°C), applicable LED ON
R-1- (f)	Low Temperature Condition	When ambient temperature is less than 72°F (22°C), applicable LED ON
F-1- (e)(f) ALL LED OFF	Normal Condition	When ambient temperature is between 73°F (23°C) and 91°F (33°C), applicable LED ON
R-1- (g)	Exhibition Mode	Display mode, applicable LED ON
F-1- (a)	Compressor	When compressor operates, applicable LED ON
F-1- (b)	Freezer Fan High	When freezer compartment fan high operates, applicable LED ON
F-1- (c)	Freezer Fan Low	When freezer compartment fan low operates, applicable LED ON
F-1- (d)	Freezer Defrost Heater	When freezer compartment defrost heater operates, applicable LED ON
R-10- (e)	Condenser Fan High	When condenser fan high operates, applicable LED ON
R-10- (f)	Condenser Fan Low	When condenser fan low operates, applicable LED ON
F-10- (g)	French Heater	When french heater operates, applicable LED ON
F-1- (g)	Dispenser Heater	When dispenser heater operates, applicable LED ON
F-10- (a)	Water Tank Heater	When water tank heater operates, applicable LED ON
F-10- (d)	Ice Room Fan High Ice	When ice room fan high operates, applicable LED ON
F-10- (e)	Ice Room Fan Low	When ice room fan low operates, applicable LED ON

Self Diagnostics – During Normal Operation

To enter self diagnostics during normal operation of the refrigerator, press the ENERGY SAVER and ALARM/ LIGHT pads for 6 seconds. The display will beep and flash. Continue to press both pads for an addition 2 seconds to enter the self-diagnostic mode.

If any failure functions are present, those segments will now begin to flash.



The self diagnostics mode will be displayed for 30 seconds, then the panel will return to normal display.

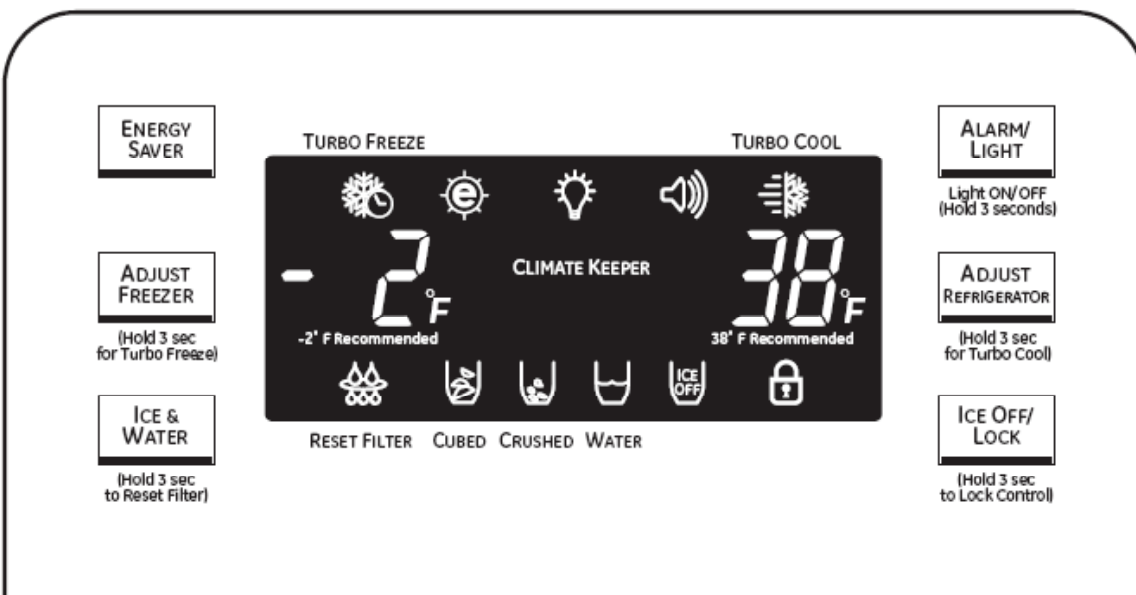

Self Diagnostics – During Normal Operation Table

LED	Item	Trouble Contents	Diagnostic Method
R-1-Ⓐ	Icemaker Sensor Error	Display error: separation of sensor housing part, contact error, disconnection, short circuit	When checking the voltage of MAIN PCB CN90 #3 to CN90 #4: should be between 4.5 to 1.0V.
R-1-Ⓑ	Refrigerator Sensor Error	Display error of detecting temperature of sensor: more than 149°F (+65°C) or less than -58°F (-50°C)	When checking the voltage of MAIN PCB CN30 #6 to CN75 #1: should be between 4.5 to 1.0V.
R-1-Ⓒ	Refrigerator Defrost Sensor Error		When checking the voltage of MAIN PCB CN #7 to CN75 #1: should be between 4.5V to 1.0V.
R-1-Ⓓ	Refrigerator Fan Error		Voltage of MAIN PCB CN75 orange to gray should be between 7v to 12V.
R-1-Ⓔ	Icemaker Error	Display error: ice making kit is harvested more than 3 times and level error. Note: Apply to the applicable icemaker model.	After replacing icemaker, check the operation by turning the appliance ON again.
R-1-Ⓕ	Refrigerator Defrost Error	Display error: separation of fresh food compartment defrost heater housing part, contact error, disconnection, short circuit or temperature fuse error Display error: the fresh food compartment defrosting does not finish. Defrost is heating continuously for more than 80 minutes.	After separating MAIN PCB CN70, CN71, from PCB, check the resistance value between CN70 white to CN71 orange. It should be 102 ohms ±7%. (Resistance value is varied by the input power.) Check 0 ohm: heater short, ∞ ohm: wire/ bimetal open.
F-1-Ⓐ	Ambient Sensor Error	Display error: sensor housing separation, contact error, disconnection, short circuit	Check the voltage of MAIN PCB CN32 #1 to #4. It should be between 4.5V to 1.0V.
F-1-Ⓑ	Freezer Sensor Error	Display error by detecting temperature of sensor: more than 149°F (+65°C) or less than -58°F (-50°C)	Check the voltage of MAIN PCB CN30 #3 to CN75 #1. It should be between 4.5V to 1.0V.
F-1-Ⓒ	Defrost Sensor Error		Check the voltage of MAIN PCB CN30 #4 to CN75 #1. It should be between 4.5V to 1.0V.
F-1-Ⓓ	Freezer Fan Error	Display error during operation of fan motor: feed back signal line contact error, motor wire separation, motor error	Voltage of MAIN PCB CN75 yellow to gray should be between 7V to 12V.
F-1-Ⓔ	Condenser Fan Error	Display error during operation of fan motor: feed back signal line contact error, motor wire separation, motor error	Voltage of MAIN PCB CN75 sky blue to gray should be between 7V to 12V.

LED	Item	Trouble Contents	Diagnostic Method
F-1- (f)	Ice Room Sensor Error	Display error: sensor housing separation, contact error, disconnection, short circuit Display error by detecting temperature of sensor: more than 149°F (+65°C) or less than -58°F (-50°C)	Check the voltage of MAIN PCB CN32 #3 to CN75 #1. It should be between 4.5V to 1.0V.
F-1- (g)	Freezer Defrost Error	Display error: separation of freezer compartment defrost heater housing part, contact error, disconnection, short circuit, or temperature fuse error Display error: The defrosting does not finish through fresh food compartment. Compartment defrost is heating continuously for more than 70 minutes.	After separating MAIN PCB CN70 and CN71 from PCB, check the resistant value between CN70 brown to CN71 orange. It should be 102 ohms ±7%. (Resistance value is varied by the input power.) Check 0 ohm: heater short, ∞ ohm: wire/bimetal open.
F-10- (b)	Ice Room Fan Error	Display error during operation of fan motor: feedback signal line contact error, motor wire separation, motor error	Voltage of MAIN PCB CN76 black to CN75 gray should be between 6V to 12V.
R-10- (a)	Pantry Damper Heater Error	Display error: when open error is detected by damper heater: separation of damper heater housing part, contact error, disconnection, short circuit	After separating MAIN PCB CN91 from PCB, check the resistant value between black to brown wire. It should be 145 ohms ±7%. Check 0 ohm: heater short, ∞ ohm: wire/bimetal open.
R-10- (b)	Pantry Sensor Error	Display error: separation of sensor housing, contact error, disconnection, short circuit Display error by detecting temperature of sensor: more than 149°F (+65°C) or less than -58°F (-50°C)	Check the voltage of MAIN PCB CN30 #8 to #9. It should be between 4.5V to 1.0V.
R-10- (g)	Water Tank Heater Error	Display error when open error is detected by water tank heater: separation of water tank heater housing part, contact error, disconnection, short circuit	After separating MAIN PCB CN78 from PCB, check the resistant value between black to brown wire. It should be 45 ohms ±7%. Check 0 ohm: heater short, ∞ ohm: wire/bimetal open.
F-10- (g)	Panel to Main Communication Error	Display of Pc/Lc Er in the panel with alarm:	It is desirable to recheck the condition with the oscilloscope after replacing Main and Panel PCBs
F-10- (f)	Load to Main Communication Error	MICOM MAIN to LOAD communication error MICOM MAIN to PANEL communication error	

Sensor Resistance / Voltage Checks Table

°C	°F	Voltage	Ohms	°C	°F	Voltage	Ohms	°C	°F	Voltage	Ohms
-50	-58	4.694	153319	-5	23	3.107	16419	40	104	1.153	2997
-49	-56.2	4.677	144794	-4	24.8	3.057	15731	41	105.8	1.124	2899
-48	-54.4	4.659	136798	-3	26.6	3.006	15076	42	107.6	1.095	2805
-47	-52.6	4.641	129294	-2	28.4	2.955	14452	43	109.4	1.068	2714
-46	-50.8	4.622	122248	-1	30.2	2.904	13857	44	111.2	1.040	2627
-45	-49	4.602	115631	0	32	2.853	13290	45	113	1.014	2543
-44	-47.2	4.581	109413	1	33.8	2.802	12749	46	114.8	0.988	2462
-43	-45.4	4.560	103569	2	35.6	2.751	12233	47	116.6	0.963	2384
-42	-43.6	4.537	98073	3	37.4	2.700	11741	48	118.4	0.938	2309
-41	-41.8	4.514	92903	4	39.2	2.649	11271	49	120.2	0.914	2237
-40	-40	4.490	88037	5	41	2.599	10823	50	122	0.891	2167
-39	-38.2	4.465	83456	6	42.8	2.548	10395	51	123.8	0.868	2100
-38	-36.4	4.439	79142	7	44.6	2.498	9986	52	125.6	0.846	2036
-37	-34.6	4.412	75077	8	46.4	2.449	9596	53	127.4	0.824	1973
-36	-32.8	4.385	71246	9	48.2	2.399	9223	54	129.2	0.803	1913
-35	-31	4.356	67634	10	50	2.350	8867	55	131	0.783	1855
-34	-29.2	4.326	64227	11	51.8	2.301	8526	56	132.8	0.762	1799
-33	-27.4	4.296	61012	12	53.6	2.253	8200	57	134.6	0.743	1745
-32	-25.6	4.264	57977	13	55.4	2.205	7888	58	136.4	0.724	1693
-31	-23.8	4.232	55112	14	57.2	2.158	7590	59	138.2	0.706	1642
-30	-22	4.199	52406	15	59	2.111	7305	60	140	0.688	1594
-29	-20.2	4.165	49848	16	60.8	2.064	7032	61	141.8	0.670	1547
-28	-18.4	4.129	47431	17	62.6	2.019	6771	62	143.6	0.653	1502
-27	-16.6	4.093	45146	18	64.4	1.974	6521	63	145.4	0.636	1458
-26	-14.8	4.056	42984	19	66.2	1.929	6281	64	147.2	0.620	1416
-25	-13	4.018	40938	20	68	1.885	6052	65	149	0.604	1375
-24	-11.2	3.980	39002	21	69.8	1.842	5832	66	150.8	0.589	1335
-23	-9.4	3.940	37169	22	71.6	1.799	5621	67	152.6	0.574	1297
-22	-7.6	3.899	35433	23	73.4	1.757	5419	68	154.4	0.560	1260
-21	-5.8	3.858	33788	24	75.2	1.716	5225	69	156.2	0.546	1225
-20	-4	3.816	32230	25	77	1.675	5039	70	158	0.532	1190
-19	-2.2	3.773	30752	26	78.8	1.636	4861	71	159.8	0.519	1157
-18	-0.4	3.729	29350	27	80.6	1.596	4690	72	161.6	0.506	1125
-17	1.4	3.685	28021	28	82.4	1.558	4526	73	163.4	0.493	1093
-16	3.2	3.640	26760	29	84.2	1.520	4369	74	165.2	0.481	1063
-15	5	3.594	25562	30	86	1.483	4218	75	167	0.469	1034
-14	6.8	3.548	24425	31	87.8	1.447	4072	76	168.8	0.457	1006
-13	8.6	3.501	23345	32	89.6	1.412	3933	77	170.6	0.446	978
-12	10.4	3.453	22320	33	91.4	1.377	3799	78	172.4	0.435	952
-11	12.2	3.405	21345	34	93.2	1.343	3670	79	174.2	0.424	926
-10	14	3.356	20418	35	95	1.309	3547	80	176	0.414	902
-9	15.8	3.307	19537	36	96.8	1.277	3428	81	177.8	0.404	877
-8	17.6	3.258	18698	37	98.6	1.253	3344	82	179.6	0.394	854
-7	19.4	3.208	17901	38	100.4	1.213	3204	83	181.4	0.384	832
-6	21.2	3.158	17142	39	102.2	1.183	3098	84	183.2	0.375	810

Sensor Resistance / Voltage Checks

Ice Maker Sensor

Resistance Check (CN90 Unplugged)

CN90 Pin# 4 to Pin# 8

Voltage Check (CN90 Connected)

CN90 Pin# 4 to CN10 Pin# 3

Ice Maker Sensor Error Code



Refrigerator Sensor

Resistance Check (CN30 Unplugged)

CN30 Pin# 6 to CN10 Pin# 3

Voltage Check (CN30 Connected)

CN30 Pin# 6 to CN10 Pin# 3

Refrigerator Sensor Error Code



Refrigerator Defrost Sensor

Resistance Check (CN30 Unplugged)

CN30 Pin# 7 to CN10 Pin# 3

Voltage Check (CN30 Connected)

CN30 Pin# 7 to CN10 Pin# 3

Refrigerator Defrost Sensor Error Code



Ambient Sensor

Resistance Check (CN32 Unplugged)

CN32 Pin# 1 to CN32 Pin# 4

Voltage Check (CN32 Connected)

CN32 Pin# 1 to CN10 Pin# 3

Ambient Sensor Error Code



Freezer Sensor

Resistance Check (CN30 Unplugged)

CN30 Pin# 3 to CN10 Pin# 3

Voltage Check (CN30 Connected)

CN30 Pin# 3 to CN10 Pin# 3

Freezer Sensor Error Code



Ice Room Sensor

Resistance Check (CN32 Unplugged)

CN32 Pin# 3 to CN10 Pin# 3

Voltage Check (CN32 Connected)

CN32 Pin# 3 to CN10 Pin# 3

Ice Room Sensor Error Code



Freezer Defrost Sensor

Resistance Check (CN30 Unplugged)

CN30 Pin# 4 to CN10 Pin# 3

Voltage Check (CN32 Connected)

CN30 Pin# 4 to CN10 Pin# 3

Freezer Defrost Sensor Error Code



Pantry Sensor

Resistance Check (CN30 Unplugged)

CN30 Pin# 8 to CN30 Pin# 9

Voltage Check (CN30 Connected)

CN30 Pin# 8 to CN10 Pin# 3

Pantry Sensor Error Code



Operational Fan Checks

Note: All fan voltage checks are from CN10 Pin# 3.

Check voltage to fans:

Freezer Fan – CN75 Pin#2 7 to 12 VDC

Refrigerator Fan – CN75 Pin#3 7 to 12 VDC

Condenser Fan – CN75 Pin#4 7 to 12 VDC

Check voltage from fans (indicates fans are turning):

Freezer Fan – CN75 Pin#5 2 to 3 VDC

Refrigerator Fan – CN75 Pin#6 2 to 3 VDC

Condenser Fan – CN75 Pin#7 2 to 3 VDC

Freezer Fan Strip Circuit

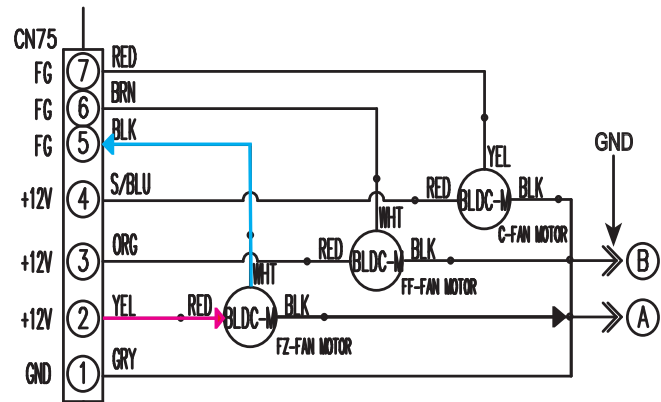

Refrigerator Fan Error Code



Refrigerator Fan Strip Circuit

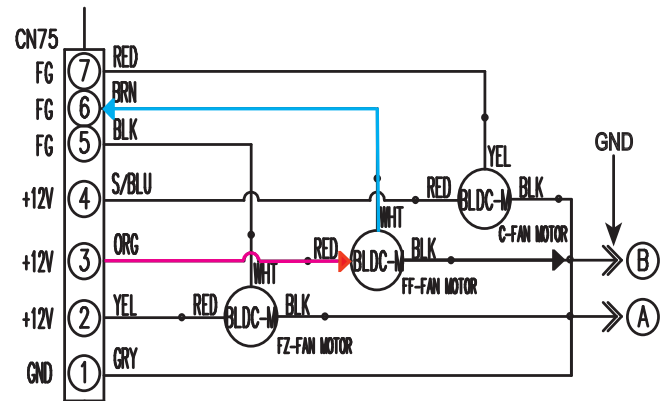

Freezer Fan Error Code



Condenser Fan Error Code



Condenser Fan Strip Circuit

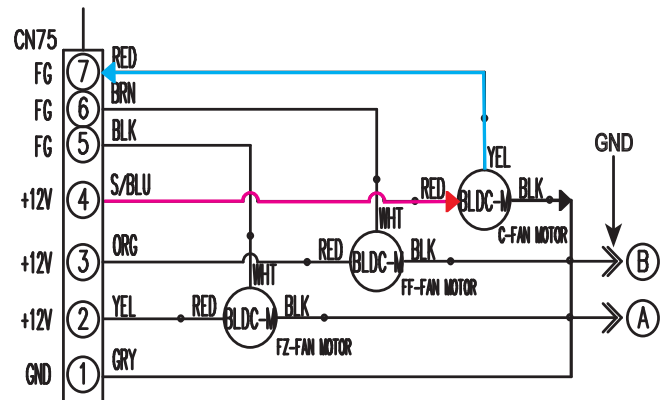

Ice Room Fan Checks

Note: All fan voltage checks are from CN10 Pin# 3

Check voltage to fan:

Ice Room Fan – CN76 Pin#1 7 to 12 VDC

Check voltage from fan (indicates fans are turning):

Ice Room Fan – CN76 Pin#2 2 to 3 VDC

Ice Room Fan Error Code

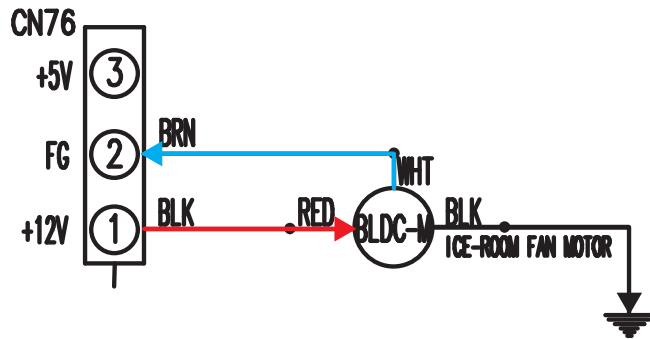

Pantry Room Damper Heater

With CN91 unplugged from the board, read resistance between pins 1 and 2 of plug.

Heater should read approximately 145 ohms.

When the heater is energized, there should be approximately 12VDC between pins 1 and 2 of CN91. (Plug connected to board)

Pantry Room Damper Heater Error Code

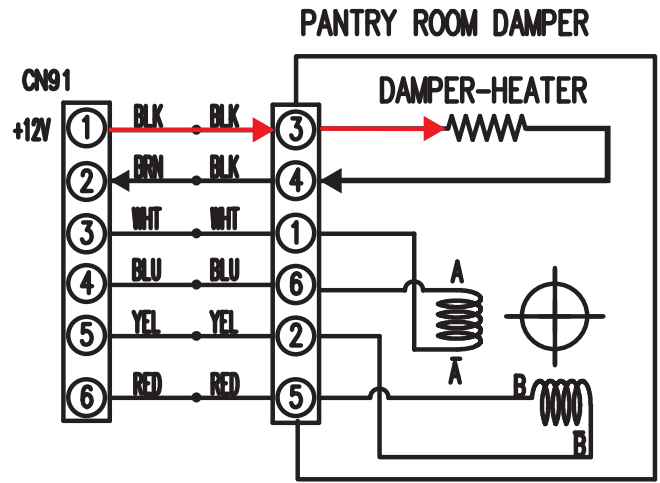

Water Tank Heater

With CN78 unplugged from the board, read resistance between pins 4 and 5 of plug.

Heater should read approximately 48 ohms. When heater is energized, there should be approximately 12VDC between pins 4 and 5 of CN78. (Plug connected to board)

Water Tank Heater Error Code

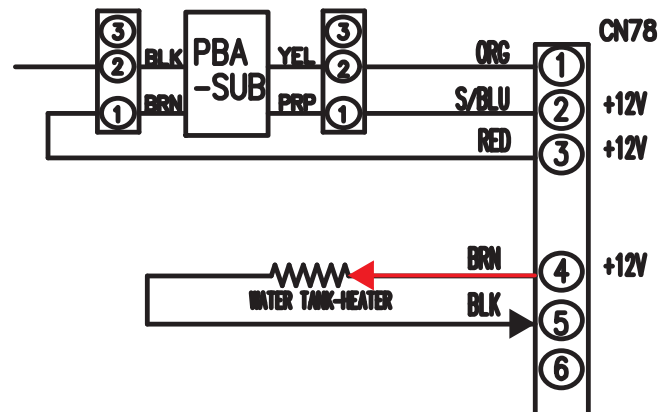

Defrost Heaters

Freezer Defrost Heater

The Freezer Defrost Heater has a resistance value of approximately 56Ω and is in a parallel circuit with the duct heater. (See *Duct Heater*.)

Disconnect CN70 from the board. Check for a combined resistance of 55Ω between pin 9 to CN71 pin 9, when the defrost safety thermostat is closed. A reading of approximately $3.18K \Omega$ will indicate an open freezer defrost heater, wiring, or connection.

Freezer Defrost Heater Error Code



Freezer Defrost Heater Circuit

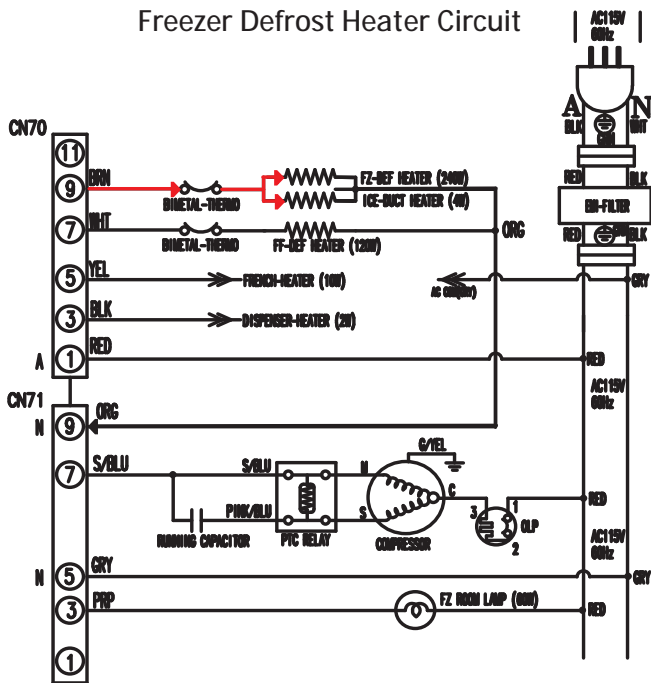

Refrigerator Defrost Heater

With CN70 unplugged from the board, read resistance between pin 7 to CN71 pin 9. Refrigerator Defrost Heater should read approximately 120 ohms.

Refrigerator Defrost Heater Error Code



Refrigerator Defrost Heater Circuit

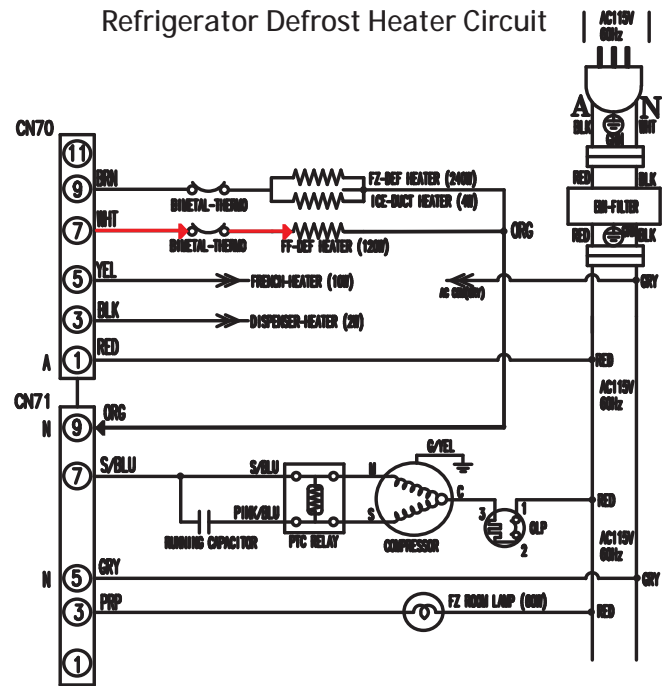

Note: To functionally test the defrost heaters, energize the heaters by using the test mode. (See *Test Mode Operation*.)

Compressor

Note: There is a 5-minute delay start with a cold cabinet.

The compressor utilizes a "Switched Neutral" circuit. The L1 side is always "hot".

Read between CN1 pin# 1 (L1) on power supply board to CN71 pin# 7. Test will show 120 VAC, if board wants compressor to run.

Compressor Circuit

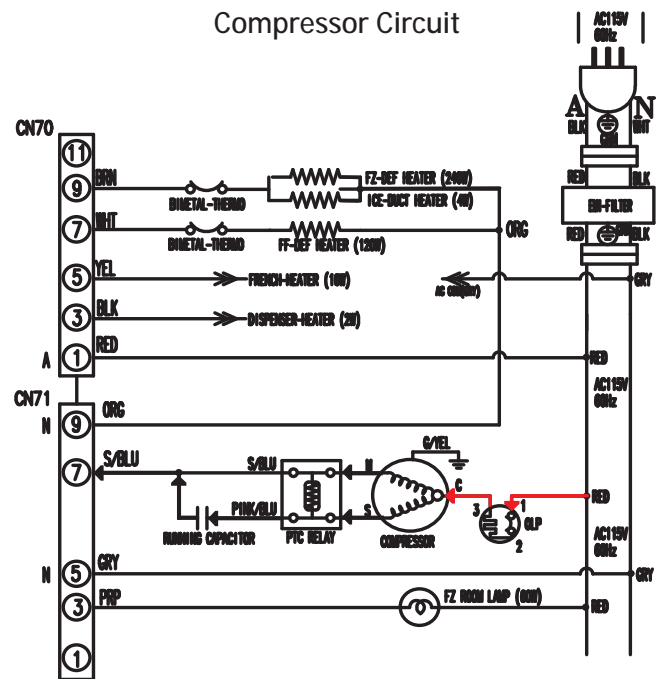

Schematic

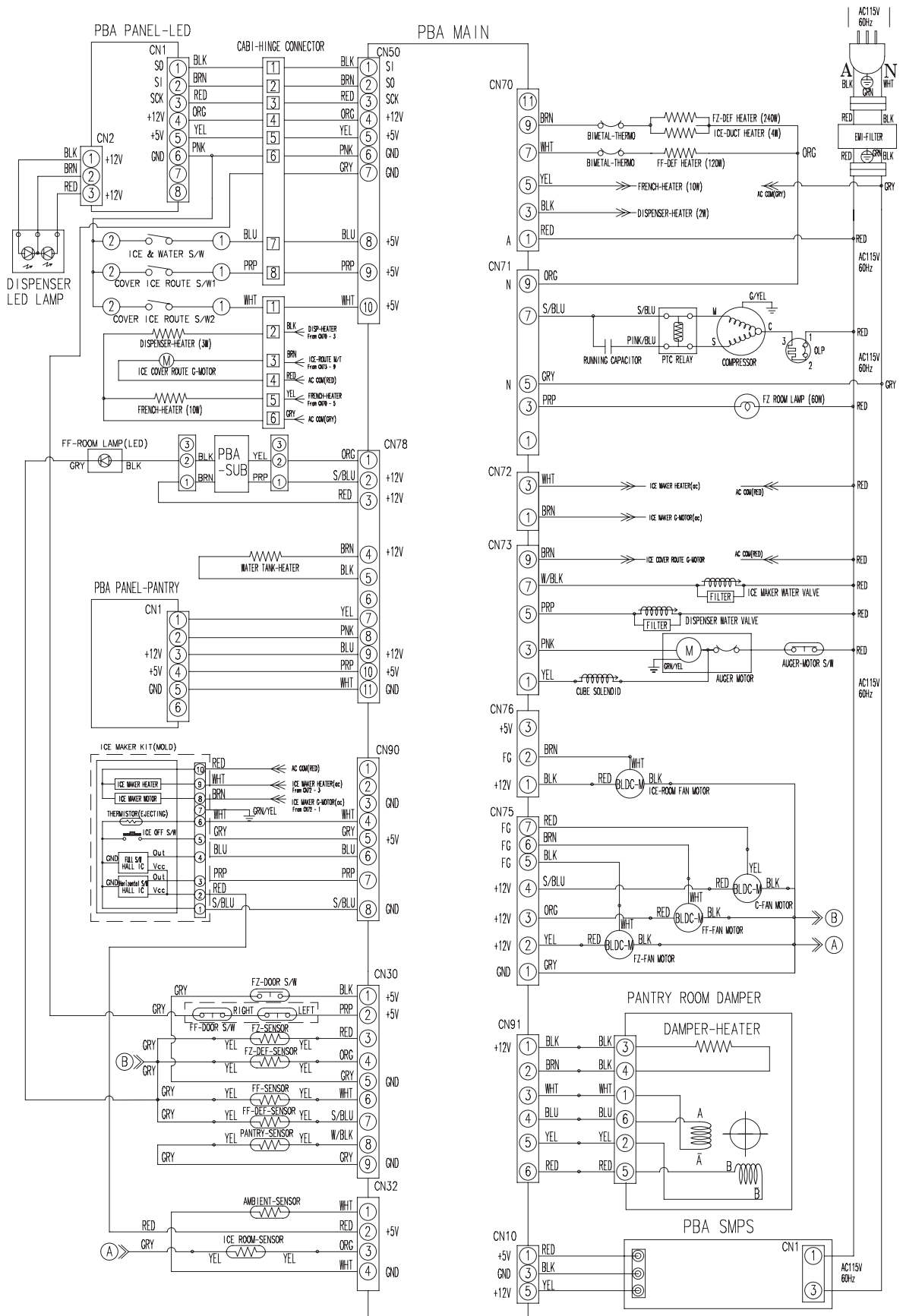

Warranty

Refrigerator Warranty. *(For customers in the United States)*



All warranty service provided by our Factory Service Centers, or an authorized Customer Care® technician. To schedule service, on-line, 24 hours a day, visit us at ge.com, or call 800.GE.CARES (800.432.2737). Please have serial number and model number available when calling for service.

Staple your receipt here.
Proof of the original purchase date is needed to obtain service under the warranty.

For The Period Of: **GE Will Replace:**

GE and GE PROFILE MODELS:

One Year

From the date of the original purchase

Any part of the refrigerator which fails due to a defect in materials or workmanship. During this **limited one-year warranty**, GE will also provide, **free of charge**, all labor and related service to replace the defective part.

Thirty Days

(Water filter, if included)
From the original purchase date of the refrigerator

Any part of the water filter cartridge which fails due to a defect in materials or workmanship. During this **limited thirty-day warranty**, GE will also provide, **free of charge**, a replacement water filter cartridge.

GE PROFILE MODELS ONLY:

Five Years

(GE Profile models only)
From the date of the original purchase

Any part of the sealed refrigerating system (the compressor, condenser, evaporator and all connecting tubing) which fails due to a defect in materials or workmanship. During this **limited five-year sealed refrigerating system warranty**, GE will also provide, **free of charge**, all labor and related service to replace the defective part in the sealed refrigerating system.

What GE Will Not Cover:

- Service trips to your home to teach you how to use the product.
- Improper installation, delivery or maintenance.
- Failure of the product if it is abused, misused, or used for other than the intended purpose or used commercially.
- Loss of food due to spoilage.
- Replacement of house fuses or resetting of circuit breakers.
- Damage caused after delivery.
- Replacement of the water filter cartridge, if included, due to water pressure that is outside the specified operating range or due to excessive sediment in the water supply.
- Replacement of the light bulbs, if included, or water filter cartridge, if included, other than as noted above.
- Damage to the product caused by accident, fire, floods or acts of God.
- Incidental or consequential damage caused by possible defects with this appliance.
- Product not accessible to provide required service.

EXCLUSION OF IMPLIED WARRANTIES—Your sole and exclusive remedy is product repair as provided in this Limited Warranty. Any implied warranties, including the implied warranties of merchantability or fitness for a particular purpose, are limited to one year or the shortest period allowed by law.

This warranty is extended to the original purchaser and any succeeding owner for products purchased for home use within the USA. If the product is located in an area where service by a GE Authorized Servicer is not available, you may be responsible for a trip charge or you may be required to bring the product to an Authorized GE Service location for service. In Alaska, the warranty excludes the cost of shipping or service calls to your home.

CUSTOMER WARRANTY

(for customers in Canada)

Your refrigerator is warranted to be free of defects in material and workmanship.

What is covered	How Long Warranted (From Date of Sale)	Parts Repair or Replace at Mabe's Option	Labour
Compressor	GE Profile: Ten (10) Years GE and All Other Brands: One (1) Year	GE Profile: Ten (10) Years GE and All Other Brands: One (1) Year	GE Profile: Five (5) Years GE and All Other Brands: One (1) Year
Sealed System (including evaporator, condenser tubing and refrigerant)	GE Profile: Five (5) Years GE and All Other Brands: One (1) Year	GE Profile: Five (5) Years GE and All Other Brands: One (1) Year	GE Profile: Five (5) Years GE and All Other Brands: One (1) Year
All Other Parts	One (1) Year	One (1) Year	One (1) Year

TERMS AND CONDITIONS:

This warranty applies only for single family domestic use in Canada when the Refrigerator has been properly installed according to the instructions supplied by Mabe and is connected to an adequate and proper utility service.

Damage due to abuse, accident, commercial use, and alteration or defacing of the serial plate cancels all obligations of this warranty.

Service during this warranty period must be performed by an Authorized Mabe Service Agent.

Neither Mabe nor the Dealer is liable for any claims or damages resulting from failure of the Refrigerator or from service delays beyond their reasonable control.

To obtain warranty service, purchaser must present the original Bill of Sale. Components repaired or replaced are warranted through the remainder of the original warranty period only.

This warranty is extended to the original purchaser and any succeeding owner for products purchased for home use within Canada. In home warranty service will be provided in areas where it is available and deemed reasonable by Mabe to provide.

This warranty is in addition to any statutory warranty.

WHAT IS NOT COVERED:

- Owner is responsible to pay for service calls related to product installation and/or teaching how to use the product.
- Damage to finish must be reported within 48 hours following the delivery of the appliance.
- Damage to finish after delivery.
- Improper installation—proper installation includes adequate air circulation to the refrigeration system, adequate electrical, plumbing and other connecting facilities.
- Replacement of house fuses or resetting of circuit breakers.
- Replacement of light bulbs.
- Damage to product caused by accident, fire, floods or acts of God.
- Loss of food due to spoilage.
- Proper use and care of product as listed in the owner's manual, proper setting of controls.
- Product not accessible to provide required service.
- WARRANTOR IS NOT RESPONSIBLE FOR CONSEQUENTIAL DAMAGES.

EXCLUSION OF IMPLIED WARRANTIES—Your sole and exclusive remedy is product repair as provided in this Limited Warranty. Any implied warranties, including the implied warranties of merchantability or fitness for a particular purpose, are limited to one year or the shortest period allowed by law.

IMPORTANT

Keep this warranty and your bill of sale as proof of original purchase and purchase date. Please have serial number and model number available when calling for service.

Mabe Service is available coast to coast. If further help is needed concerning this warranty, contact:

Manager, Consumer Relations
Mabe Canada Inc., Consumer Service
1 Factory Lane, Suite 310
Moncton, New Brunswick E1C 9M3
1.800.561.3344

*Staple your receipt here.
Proof of the original purchase
date is needed to obtain service
under the warranty.*