

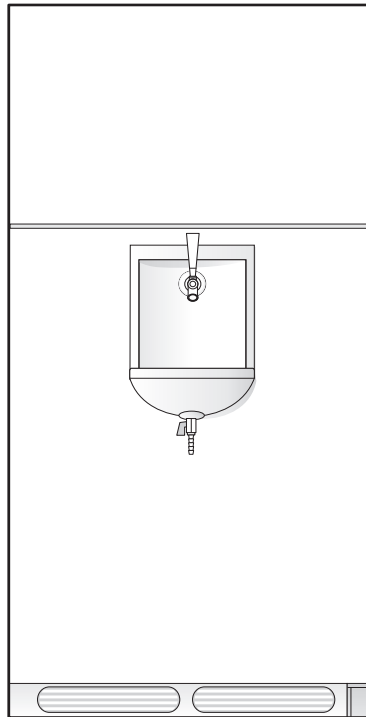

ELECTROLUX HOME PRODUCTS NORTH AMERICA

SERVICE MANUAL



BEVERAGE CENTER II

Kelvinator  ***TAPPAN***[®]

Gibson[®]  ***White-Westinghouse***[®]

Frigidaire

TABLE OF CONTENTS

SAFE SERVICING PRACTICES	5
INSTALLATION INSTRUCTIONS	
Important Safety Instructions	6
Electrical Information	6
Installation	7
Leveling	7
To Adjust Front Leveling Screw	7
Installation Water Line	8
Door Removal and Reversal Instructions	9
To Remove Freezer Door	9
To Remove Refrigerator Door	9
To Remove Center Hinge	9
To Remove Lower Hinge	9
To Reverse Freezer and Refrigerator Door Stops	9
To Install Lower Hinge On Opposite Side	9
To Install Center Hinge On Opposite Side	9
To Install Refrigerator Door	9
To Install Freezer Door	9
FEATURES AT A GLANCE	
Cool Down Period	10
Beverage Center Controls	10
Temperature Control	10
Air Flow Control	10
Temperature Settings and Adjustment	10
FIRST STEPS	
Parts	11
Beverage Delivery Kit Box	11
Faucet Assembly Installation	12
Sump and Drip Tray Installation	12
Sump Valve Installation	12
Regulator Installation	12
Braided Hose to Regulator Connections	13
Braided Hose to Coupler Connection	13
Clear Hose to Coupler Connection	13
Clear Hose to Door Panel Connection	13
Clear Hose to Keg Installation	13
Delivery Hose Pressurization	14
CO ₂ Canister to Cabinet Installation	14
Keg to Cabinet Installation	14
Tips on Installing the Keg to the Cabinet	14
Delivery Hose Arrangement	15
Operating the Beverage Center	15
How to Replace Empty CO ₂	15
Helpful Hints	16
Beer Storage Temperature	16
Recommended Keg Handling	16
BEVERAGE COOLER EXTRA FEATURES	
Optional Caster Kit	16
Optional Ice Maker Kit	17
NORMAL OPERATING SOUNDS & SIGHTS	
Understanding the Sounds You May Hear	18

CARE & CLEANING

Care & Cleaning Chart	19
Proper Cleaning of Beverage Center Dispensing System	20

WARRANTY INFORMATION

Beverage Center Warranty	21
--------------------------------	----

TROUBLESHOOTING GUIDE

Beverage Center Operation	22
Sound and Noise	22
Water / Moisture / Frost Inside Beverage Center	23
Odor in Beverage Center	23
Door Problems	23
Common Draft Problems	23

ELECTRICAL COMPONENTS

Electrical Grounding	24
Compressor Electrical Components and Circuits	24
Solid State Relay	24
To Check/Replace Relay	24
Overload Protector	24
To Check/Replace Overload Protector	25
Run Capacitor	25
To Check/Replace Run Capacitor	25
Compressor Start Circuit	25
Compressor Run Circuit	25
Compressor Operating Characteristics	26
Compressor Electrical Check	26
Control Thermostat	26
Automatic Defrost Models	26
Temperature Control Mounting	26
To Remove Temperature Control	26
To Remove Refrigerator Light Socket	27
To Remove Freezer Light Socket	27
Light Switch	27
Damper Control	27
Perimeter Hot Tube	27
Evaporator Fan and Motor Assembly	27
To Remove Freezer Fan Motor	27-28
Defrost Timer	29
To Remove Defrost Timer	29
To Check Defrost Timer	29
Defrost Thermostat	29
To Remove Defrost Thermostat	29
To Test Defrost Thermostat	29
Defrost Heater	29
To Remove Defrost Heater	29-30
Service Data Sheet	31
Ladder Schematic	32
Wiring Diagram	33

AIR CIRCULATION

Automatic Defrost Models	34
Principles of Automatic Defrost Operation	34
Air Circulation Patterns	34

REFRIGERATION SYSTEM

Definitions	35
-------------------	----

Recovery	35
Recycling	35
Reclaim	35
Safety Warnings	35
Compressor Testing	35
Charging Sealed Systems	36
Soldering	36
Basic Components	36
Perimeter Hot Tube	36
Refrigerant Cycle	36
Low or Low-Side Leak or Undercharge	35-37
Testing For Refrigerant Leaks	37
Checking For Internal (Hot Tube) Leaks	37
Compressor Replacement	37
To Flush The System	37
To Use Dry Nitrogen To Flush The System	38-38
To Use Refrigerant To Flush The System	38
Installing A New Compressor	38-38
Evaporator Replacement	40-41
Heat Exchanger Replacement	41-42
Perimeter Hot Tube Repair Kit	42-43
Bypassing Perimeter Hot Tube - Step 1	43
Installing The Heater Wire - Step 2	43
Installing The Heater Wire - Step 3	43
Condenser Replacement	43-44
Suction Line And Capillary Tube Replacement	44
Filter-Drier Installation	44
Evacuating And Recharging	44
Equipment Needed	44
Installing Evacuation And Recharging Equipment	45
Evacuating System	45
Charging The System	45-46
Final Leak Test	46
R-134a Service Information	47
Verify Refrigerant Type In The System	47
Dedicated Equipment	47
R-134a Refrigeration Systems	47
Miscibility Of R-134a And Ester Oil	47
Water In The Refrigeration System	48
Vacuum Chart	48
Vacuum Pump Maintenance	48
Refrigerant Leaks	48
Leak Detection	49
R-134a Properties	49
HFC-134a, CFC-12 Pressure Temperature Chart	50
R-134a Health And Safety Information	51
Inhalation Toxicity	51
Cardiac Sensitization	51
Spills Or Leaks	51
Skin And Eye Contact	51
Combustibility Of HFC-134a	52
Leak Testing	52
Bulk Delivery And Storage	52
Filling And Charging Operations	52
Refrigerant Recovery Systems	52
Thermal Decomposition	52

ICE MAKER

Ice Maker For Top Mount Models	53
Front Cover	53
Ice Maker Components	53
Ice Mold	53
Mold Heater	53
Ice Stripper	53
Ice Ejector	53
Water Valve Assembly	53
Thermostat	54
Sensing Arm & Linkage	54
Timing Switches	54
TCO - Thermal Cut-Out	54
Timing Cam & Coupler	54
Timing Gear	54
Motor	54
Fill Trough	54
Wiring	54
Installing Water Supply Line To Ice Maker	55
Test Cycling Ice Maker	55
Water Valve Switch - Water Fill Volume	55
Parts Replacement	55
To Replace Front Cover	55
To Replace Fill Trough & Bearings	56
To Replace Ice Stripper	56
To Replace Ejector Blades	56
To Replace Motor & Switch Mounting Plate	56
To Replace Motor	56
To Replace Water Fill Switch	56
To Replace Hold Switch	57
To Replace Ice Maker Control Shut-Off Switch	57
To Replace Ice Maker Thermostat	57
To Replace TCO	57
To Replace Mold Heater	58
Fault Diagnosis	58
Complaint - Ice Maker Fails To Start	58
Complaint - Ice Maker Fails To Complete Cycle	58
Complaint - Ice Maker Fails To Stop At End Of Cycle	58
Complaint - Ice Maker Continues To Eject When Container Is Full	58
Complaint - Ice Maker Produces Undersized Ice Pieces	58
Ice Maker Testing Procedures	59
Operating Cycle	59
Operating Cycle Illustrations - Manual Cycle	59
Operating Cycle Illustrations - Electrical	59-66
Operating Cycle Illustrations - Mechanical	66-68
Ice Maker - Exploded View	69
Ice Maker Wiring Diagrams - Enlarged View	70
Ice Maker Installation Instructions	71

SAFE SERVICING PRACTICES - ALL APPLIANCES

To avoid personal injury and/or property damage, it is important that **Safe Servicing Practices** be observed. The following are some limited examples of safe practices:

1. **DO NOT** attempt a product repair if you doubt your ability to complete it in a safe and satisfactory manner.
2. Before servicing or moving an appliance:
 - Remove power cord from the electrical outlet, trip circuit breaker to the **OFF** position, or remove fuse
 - Turn off gas supply
 - Turn off water supply
3. Never interfere with the proper operation of any safety device.
4. **Use The Correct Replacement Parts Cataloged For This Appliance. Substitutions May Defeat Compliance With Safety Standards Set For Home Appliances.**
5. **GROUNDING:** The standard color code for safety ground wires is **GREEN**, or **GREEN** with **YELLOW STRIPES**. **DO NOT** use ground leads as current carrying conductors. It is **EXTREMELY** important that the service technician reestablish all safety grounds prior to completion of service. Failure to do so will create a hazard.
6. Prior to returning the product to service, ensure that:
 - All electrical connections are correct and secure
 - All electrical leads are properly dressed and secured away from sharp edges, high-temperature components, and moving parts
 - All non-insulated electrical terminals, connectors, heaters, etc. are adequately spaced away from all metal parts and panels
 - All safety grounds (both internal and external) are correctly and securely connected
 - All panels are properly and securely reassembled

WARNING

This service manual is intended for use by persons having electrical and mechanical training and a level of knowledge of these subjects generally considered acceptable in the appliance repair trade. Frigidaire Home Products cannot be responsible, nor assume any liability, for injury or damage of any kind arising from the use of this manual.

IMPORTANT SAFETY INSTRUCTIONS

WARNING

Please Read All Instructions Before Using or Servicing This beverage center.

FOR YOUR SAFETY

- Do not store or use gasoline, or other flammable liquids in the vicinity of this or any other appliance. Read product labels for warnings regarding flammability and other hazards.
- Do not operate the beverage center in the presence of explosive fumes.
- Avoid contact with any moving parts of the automatic ice maker. (some models)

CHILD SAFETY

Destroy or recycle the carton, plastic bags, and any exterior wrapping material immediately after this beverage center is unpacked. Children should **NEVER** use these items to play with. Cartons covered with rugs, bedspreads, plastic sheets or stretch wrap may become airtight chambers, and can quickly cause suffocation.

WARNING

These guidelines must be followed to ensure that safety mechanisms in this beverage center will operate properly.

ELECTRICAL INFORMATION

- **The beverage center must be plugged into its own dedicated 115 Volt, 60 Hz., AC only electric outlet.** The power cord of the appliance is equipped with a three-prong grounding plug for your protection against electrical shock hazards. It must be plugged directly into a properly grounded three-prong receptacle. The receptacle must be installed in accordance with local codes and ordinances. Consult a qualified electrician. **Do not use an extension cord or adapter plug.**
- If the power cord is damaged, it should be replaced by the manufacturer, service technician or a qualified person to prevent any risk.
- Never unplug this beverage center by pulling on the power cord. Always grip the plug firmly, and pull straight out from the receptacle to prevent damaging the power cord.
- Unplug this beverage center before cleaning and before replacing a light bulb to avoid electrical shock.
- Performance may be affected if the voltage varies by 10% or more. Operating this beverage center with insufficient power can damage the compressor. Such damage is not covered under your warranty.
- Do not plug the unit into an outlet controlled by a wall switch or pull cord to prevent this beverage center from being turned off accidentally.
- Avoid connecting this beverage center to a Ground Fault Interruptor (GFI) circuit.

PROPER DISPOSAL OF YOUR BEVERAGE CENTER

Risk of child entrapment

Child entrapment and suffocation are not problems of the past. Junked or abandoned refrigerators or freezers are still dangerous – even if they will sit for “just a few days.” If you are getting rid of your old refrigerator or freezer, please follow the instructions below to help prevent accidents.

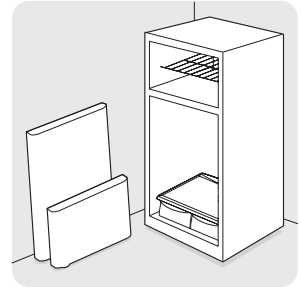

Before you throw away your old refrigerator/ freezer:

- Remove doors.
- Leave shelves in place so children may not easily climb inside.
- Have refrigerant removed by a qualified service technician.

IMPORTANT

Turning the Air Flow and Temperature Controls to “0” turns off the compressor and prevents your Beverage Center from cooling, but does not disconnect the power to the light bulb and other electrical components. To turn off power to your Beverage Center you must unplug the power cord from the wall outlet.

Grounding type wall receptacle



Do not, under any circumstances, cut, remove, or bypass the grounding prong.

Power cord with 3-prong grounded plug

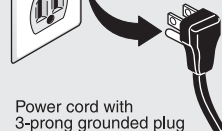

WARNING

CO₂ CANISTER SAFE HANDLING

- CO₂ canisters must be handled with extreme care. They contain potentially hazardous high pressure compressed gas.
- **ALWAYS** connect CO₂ gas canisters to a pressure regulator.
- **NEVER** drop or throw the CO₂ canister.
- **NEVER** connect gas canister directly to keg.
- **ALWAYS** keep CO₂ canisters in a cool place (70° or less) and away from heat.
- In case of CO₂ leakage, ventilate and evacuate the area immediately.
- **ALWAYS** keep canister secured in an upright position.
- Check the Department of Transportation (D.O.T.) test date on the canister neck and do not use if older than 5 years.
- Return outdated canister to your gas supplier for one that is within the time limit.

INSTALLATION

This Service Manual provides specific operating instructions for your model. The customer should use this beverage center only as instructed in the Use & Care Manual. **Before starting this beverage center, follow these important first steps.**

LOCATION

- Choose a place that is near a grounded electrical outlet. **Do Not** use an extension cord or an adapter plug.
- If possible, place this beverage center out of direct sunlight and away from the range, dishwasher or other heat sources.
- This beverage center must be installed on a floor that is level and strong enough to support a fully loaded beverage center.
- Consider water supply availability for models equipped with an automatic ice maker.

CAUTION

- **Do Not install the beverage center where the temperature will drop below 55°F (13°C) or rise above 110°F (43°C). The compressor will not be able to maintain proper temperatures inside the beverage center.**
- **DO NOT block the toe grille on the lower front of your beverage center. Sufficient air circulation is essential for the proper operation of your beverage center.**
- **THIS BEVERAGE CENTER IS NOT INTENDED FOR OUTDOOR USE.**

INSTALLATION

Installation Clearances

- Allow the following clearances for ease of installation, proper air circulation, and plumbing and electrical connections:

Sides & Top	3/8"
Back	1"

DOOR OPENING

NOTE

If the beverage center is placed with the door hinge side against a wall, you may have to allow additional space so the door can be opened wider.

The beverage center should be positioned to allow easy access to a counter when removing food. To make this possible, the direction in which the doors open can be reversed. See *Door Removal & Reversal Instructions*.

LEVELING

All four corners of the beverage center must rest firmly on a solid floor. The beverage center is equipped with adjustable leveling screws to help level your unit.

To Level Your

Beverage Center:

1. Remove toe grille.
2. Use adjustable wrench to adjust leveling screws.

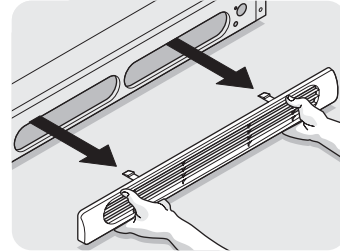

NOTE

Raise the front of the beverage center enough so the doors close freely when opened halfway. The beverage center should slope 1/4" to 1/2" from front to back. Then level the beverage center from side to side.

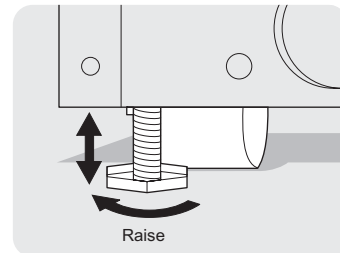

Stationary Front Roller with Leveling Screw

CAUTION

DO NOT ATTEMPT TO MOVE OR RELOCATE THE BEVERAGE CENTER WITH A KEG INSIDE. THE TWO FRONT LEVELING SCREWS MUST BE RAISED BEFORE YOU MOVE THE REFRIGERATOR TO PREVENT FLOOR DAMAGE.

INSTALLATION - CONNECTING ICE MAKER TO WATER SUPPLY

WARNING

To avoid electric shock, which can cause death or severe personal injury, disconnect the beverage center from electrical power before connecting a water supply line to the beverage center, or before servicing the beverage center.

CAUTION

To Avoid Property Damage:

- Copper tubing is recommended for the water supply line. Water supply tubing made of ¼" plastic is not recommended since it greatly increases the potential for water leaks. Manufacturer will not be responsible for any damage if plastic tubing is used for supply line.
- DO NOT install water supply tubing in areas where temperatures fall below freezing.
- Chemicals from a malfunctioning softener can damage the ice maker. If the ice maker is connected to soft water, ensure that the softener is maintained and working properly.

IMPORTANT

Ensure that your water supply line connections comply with all local plumbing codes.

Before Installing The Water Supply Line, You Will Need

- **Basic Tools:** adjustable wrench, flat-blade screwdriver, and Phillips™ screwdriver
- Access to a household cold water line with water pressure between 30 and 100 psi.
- A water supply line made of ¼ inch (6.4 mm) OD, copper tubing. To determine the length of copper tubing needed, you will need to measure the distance from the ice maker inlet valve at the back of the beverage center to your cold water pipe. Then add approximately 7 feet (2.1 meters), so the beverage center can be moved out for cleaning (as shown).
- A shutoff valve to connect the water supply line to your household water system. **DO NOT** use a self-piercing type shutoff valve.
- A compression nut and ferrule (sleeve) for connecting the water supply line to the ice maker inlet valve.

NOTE

Water line kit number 5303917950, available from your appliance dealer or part distributor, contains 25 feet (7.6 meters) of ¼ inch OD copper tubing, a saddle type shut off valve (nonpiercing), (2) ¼ inch brass compression nuts, (2) ferrules/sleeves, and instructions for installing a water supply line.

To Connect Water Supply Line To Ice Maker Inlet Valve

1. Disconnect beverage center from electric power source.
2. Place end of water supply line into sink or bucket. Turn ON water supply and flush supply line until water is clear. Turn OFF water supply at shutoff valve.
3. Unscrew plastic cap from water valve inlet and discard cap.
4. Slide brass compression nut, then ferrule (sleeve) onto water supply line, as shown.
5. Push water supply line into water valve inlet as far as it will go (¼ inch). Slide ferrule (sleeve) into valve inlet and finger tighten compression nut onto valve. Tighten another half turn with a wrench; **DO NOT** over tighten.
6. With steel clamp and screw, secure water supply line to rear panel of beverage center as shown.
7. Coil excess water supply line (about 2½ turns) behind beverage center as shown and arrange coils so they do not vibrate or wear against any other surface.
8. Turn ON water supply at shutoff valve and tighten any connections that leak.
9. Reconnect beverage center to electrical power source.
10. To turn ice maker on, lower wire signal arm (see ice maker front cover for ON/OFF position of arm).

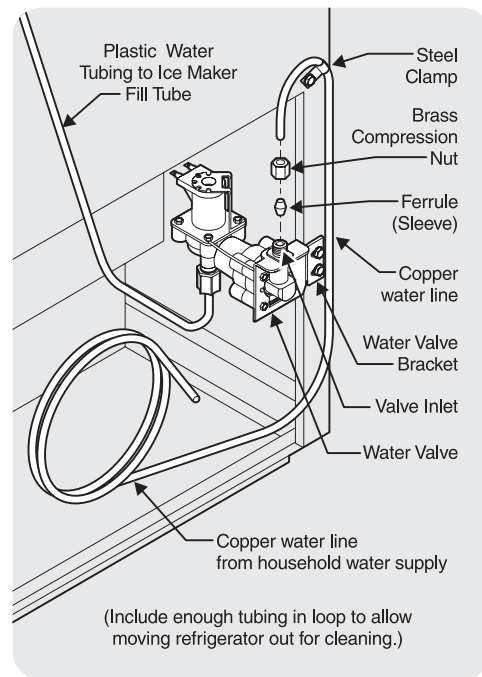

IMPORTANT

It takes approximately 24 hours for the ice maker to begin producing ice. Air in new plumbing lines may cause ice maker to cycle two or three times before making a full tray of ice. New plumbing may cause ice to be discolored or have poor flavor. Discard ice made during the first 24 hours.

DOOR REMOVAL / REVERSAL INSTRUCTIONS

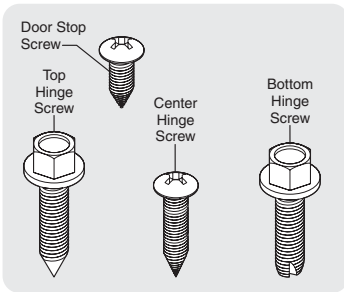

Tools Necessary:

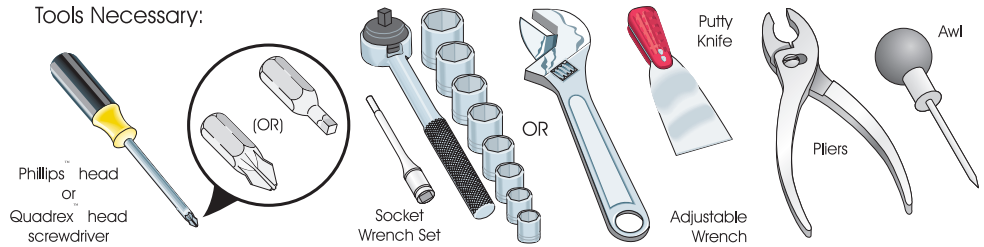

DOOR REMOVAL AND REVERSAL INSTRUCTIONS:

NOTE

The direction in which your beverage center doors open (door swing) can be reversed, from left to right or right to left, by moving the door hinges from one side to the other. Reversing the door swing should be performed by a qualified person.

IMPORTANT

Before you begin, turn the beverage center temperature control to "0" and remove the electrical power cord from the wall outlet. Remove any food from door shelves.

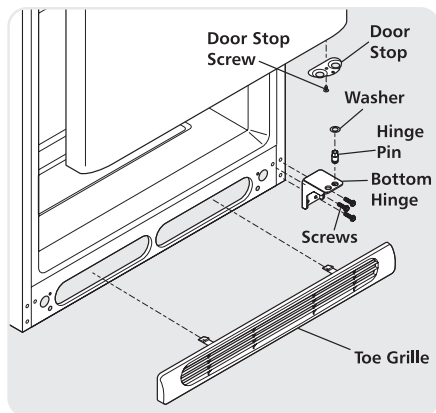
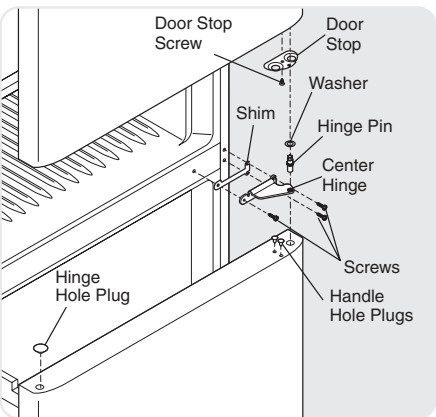
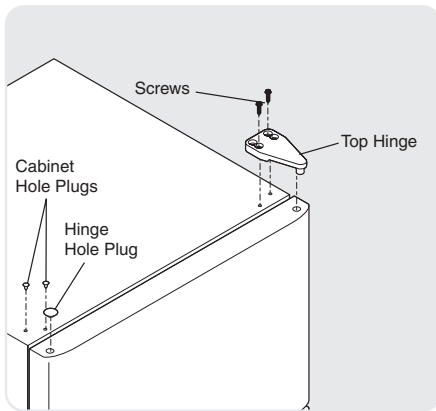

1. Remove toe grille.
2. Remove top hinge with 3/8" hex driver and lift freezer door off of center hinge pin. Set door aside.
3. Unscrew center hinge pin using adjustable wrench and save for reassembly. Ensure plastic washer stays on hinge pin.
4. Lift refrigerator door off of bottom hinge and set aside.
5. Remove center hinge and shim by removing inside screw and loosening two outside screws enough to allow hinge and shim to slide out. Tighten screws.
6. Loosen two outside screws on opposite side of refrigerator, remove inside screw and install center hinge.
7. Remove two screws on bottom hinge with 3/8" socket wrench.
8. Install bottom hinge on opposite side with the two screws removed from step 7.
9. Unscrew bottom hinge pin using adjustable wrench. Move hinge pin to other hole in hinge and tighten with adjustable wrench.
10. Move beverage center door stops to opposite side. Before starting screws, use an awl to puncture the foam.
11. Position beverage center door onto bottom hinge pin and screw center hinge pin through center hinge into top of door. Close beverage center door to help align hinge hole.
12. Tighten center hinge pin with adjustable wrench.
13. Remove cabinet and hinge hole plugs and move to opposite side.
14. Lower freezer door onto center hinge pin.
15. Close freezer door. Have an assistant lift up on opposite side of door while tightening screws to install top hinge.
16. Replace toe grille.
17. Plug in electrical power cord and turn beverage center temperature control to the "5" position. Adjust setting as necessary.

FEATURES AT A GLANCE

Features may vary according to model

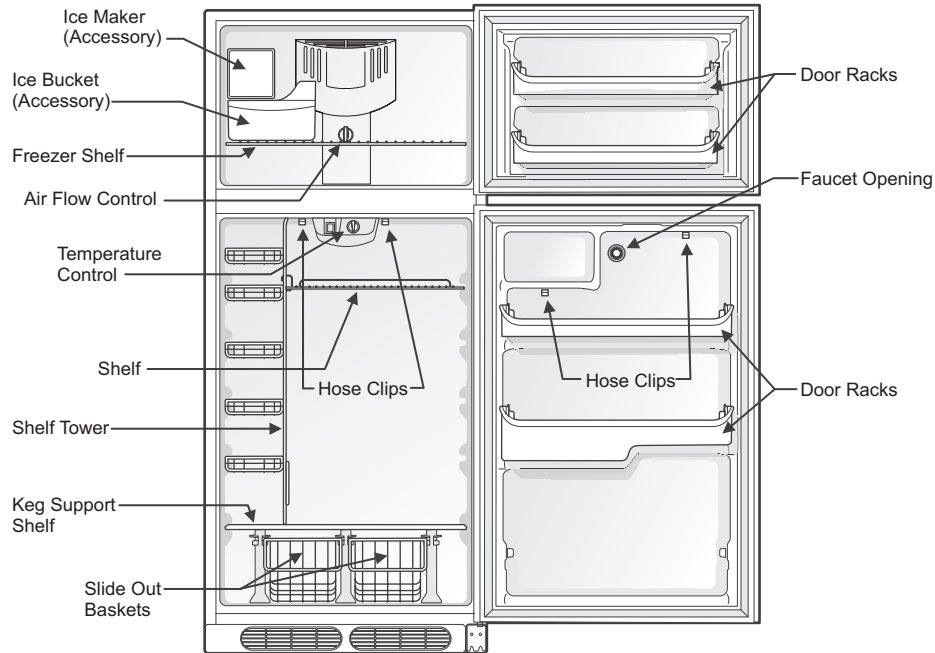

TEMPERATURE CONTROLS

COOL DOWN PERIOD

To ensure safe food storage, allow the beverage center to operate with the doors closed for at least 12 hours before loading it with food and beverages.

BEVERAGE CENTER CONTROLS

Temperature Control

This rotary control is the primary control for the refrigerated compartment temperature. If the beverage center is too warm, adjust this control in the “Colder” direction. If the beverage center is too cold, adjust this control in the “Cold” direction.

Air Flow Control

This rotary control is the primary control for the freezer compartment temperature. If the freezer is too warm, adjust this control in the “Colder” direction. If the freezer is too cold, adjust this control in the “Cold” direction.

TEMPERATURE SETTING AND ADJUSTMENT

For beer storage, the recommended initial setting is 5. Under most conditions, this setting will provide for dispensed beer between 34-38° F. You may adjust as required to suit your individual taste and the beverage center operating conditions. **After a control adjustment, always allow 24 hours for the beer to stabilize at the new temperature before making additional adjustments.**

NOTE

When purchasing a beer keg, always purchase a keg cold (<38°F), transport as quickly as possible, and get it installed in the cold beverage center within 2 hours. Under most conditions, these guidelines will allow serving of properly cooled beer within 24 hours. Purchasing a keg at a temperature above 38°F, and/or exposure to elevated temperatures longer than 2 hours will require additional time for the beer to be cooled to optimum serving temperature.

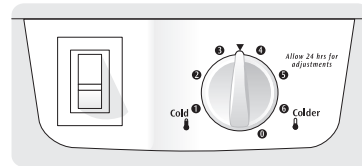

Temperature Control (some models)

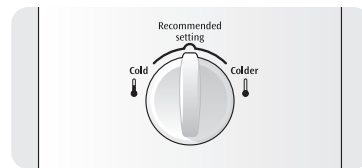

Air Flow Control (some models)

To maintain temperatures, a fan circulates air in the beverage center compartments. For good circulation, do not block cold air vents with food items.

IMPORTANT

Turning the beverage center temperature control to “0” turns off the compressor, but does not disconnect the power to the light bulb and other electrical components. To turn off power to your beverage center, you must unplug the power cord from the wall outlet.

FIRST STEPS

This Service Manual provides specific assembly, operating and maintenance instructions for the Beverage Center. The beverage center should only be used as instructed in the Use and Care Manual provided with the product. **Before starting the beverage center, follow these important first steps.**

PARTS

The beverage center comes with a box that contains all the required parts and accessories. Check to make sure that you have received the box containing all of the components listed below. You will need the following tools to assemble the beverage center.

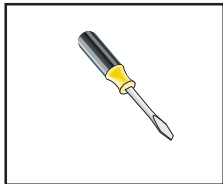

Flat Tip
Screwdriver

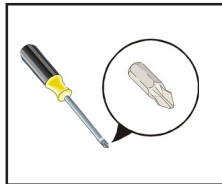

Phillips™
Screwdriver

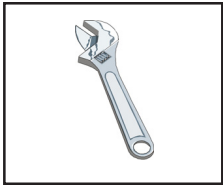

Adjustable Wrench

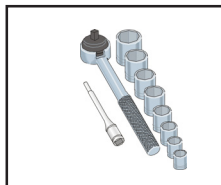

Socket Wrench

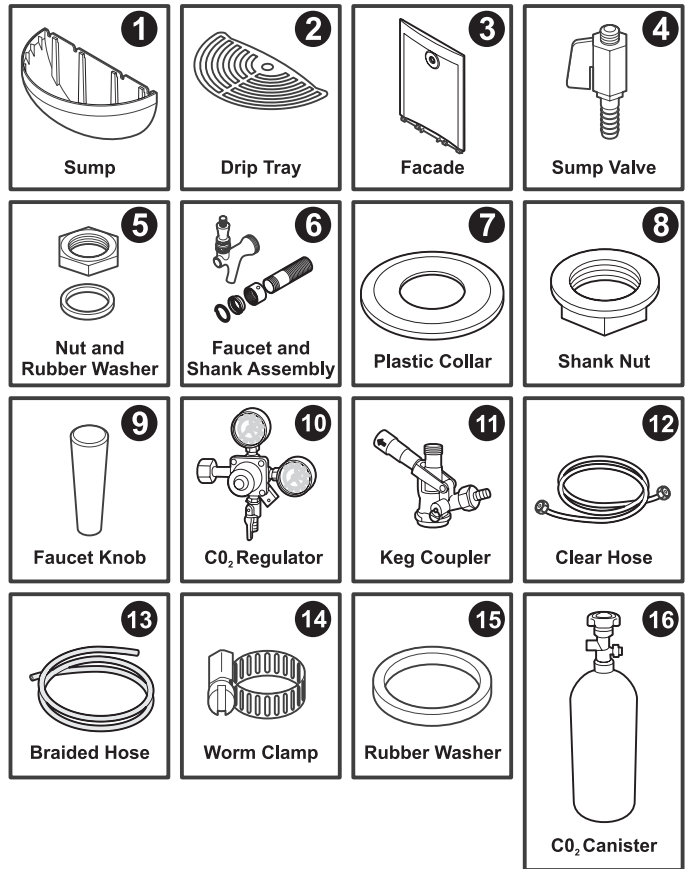

BEVERAGE DELIVERY KIT BOX

(1) Sump	1 piece
(2) Drip Tray	1 piece
(3) Facade	1 piece
(4) Sump Valve	1 piece
(5) Nut & Rubber Washer (Black) (1 nut and 2 washers included with sump valve)	2 pieces
(6) Faucet and Shank Assembly	1 piece
(7) Plastic Collar	1 piece
(8) Shank Nut	1 piece
(9) Faucet Knob	1 piece
(10) CO ₂ Regulator (with plastic washer)	1 piece
(11) Keg Coupler	1 piece
(12) Clear Hose (Delivery Line)	1 piece
(13) Braided Hose (Gas Line)	1 piece
(14) Worm Clamp (Included with Gas Line Hose)	2 pieces
(15) Rubber Washer (Black) (Included with Delivery Line Hose)	2 pieces
(16) CO ₂ Canister (Empty)	1 piece

NOTE

The box comes with a "D System" type Keg Coupler (11). Depending on your choice of beer, you may require a different Keg Coupler (11). Check with your local beer distributor to determine which type system you need, and order additional Key Couplers as needed. For assistance call **Electrolux Consumer Services at 1-800-944-9044.**

FIRST STEPS (continued)

FAUCET ASSEMBLY INSTALLATION

- Attach faucet knob (9) to Faucet & Shank Assembly (6).
- Slip the Faucet & Shank Assembly (6) through the black plastic collar (7) (flat side toward door), Facade (3), and hole in door.
- Thread on the large Shank Nut (8) and tighten until snug, using an adjustable wrench. **DO NOT** over tighten.

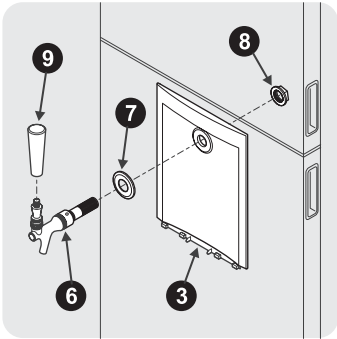

CAUTION

Replacing the faucet knob (9) with a longer knob is not recommended. This may interfere with the opening of the freezer door causing beverage spillage and/or damage to the faucet assembly and door.

SUMP AND DRIP TRAY ASSEMBLY INSTALLATION

- Remove bottom mounting screw.
- Align the two notched mounting tabs on back of sump (1) with upper mounting screws in door and push up.
- Install bottom mounting screw through slot and tighten.

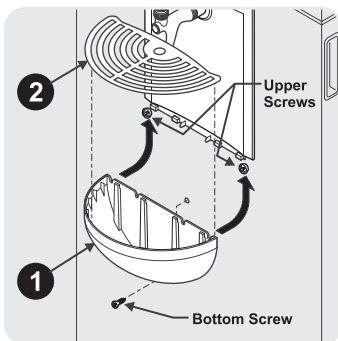

SUMP VALVE INSTALLATION

- Place one rubber washer (5) on threaded end of sump valve (4).
- Slip sump valve with washer through hole in bottom of sump (1).
- Place remaining rubber washer (5) over threaded end of sump.
- Thread plastic nut (5) onto threaded end of sump valve and tighten until snug.
- Make sure knob on valve is located to front for proper operation.
- Place Drip Tray (2) onto the Sump (1).

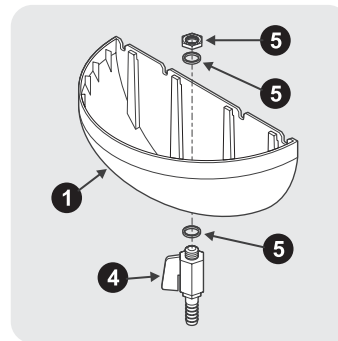

REGULATOR INSTALLATION

- Check to ensure plastic washer is inside the hex nut.

NOTE

If the plastic washer is missing, please call **Electrolux Consumer Services at 1-800-944-9044** or your part distributor for the washer.

- Fasten the CO₂ regulator (10) to the CO₂ canister (16). Place the regulator to the right of the tank.
- Tighten the hex nut securely. **DO NOT** over tighten. Over tightening may damage the gasket in the nut of the regulator.

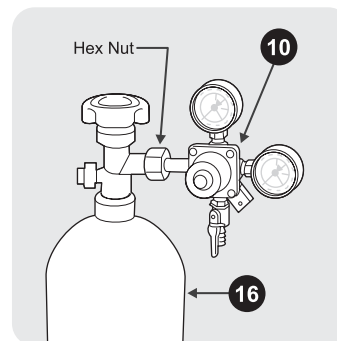

FIRST STEPS (continued)

BRAIDED HOSE TO REGULATOR CONNECTION

- Slip one Worm Clamp (14) onto braided hose (13).
- Attach that end of the braided hose (13) to the hose barb of the CO₂ regulator (10). Push hose up until seated against hex head.
- Secure the braided hose (13) to the CO₂ regulator (10) using the worm clamp (14). Use a flat tip screwdriver to tightly secure the worm clamp.

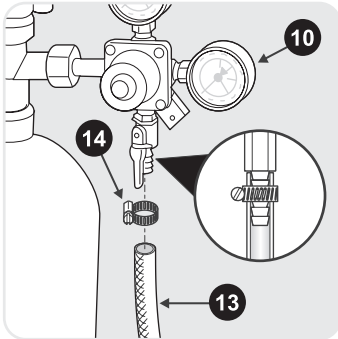

BRAIDED HOSE TO COUPLER CONNECTION

- Slip one Worm Clamp (14) onto the other end of the braided hose (13).
- Push the other end of the braided hose (13) onto the keg coupler (11) until seated against hex head.
- Secure the hose (13) to the keg coupler (11) using the remaining worm clamp (14). Use a flat tip screwdriver to tightly secure the worm clamp to the braided hose to prevent gas leakage.

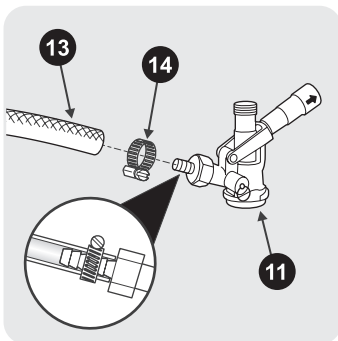

NOTE

Depending on the customer's choice of beer, they may require a different Keg Coupler (11). The customer will need to check with their local beer distributor to determine which type system they need, and order additional Keg Couplers if needed. For assistance the customer can call **Electrolux Consumer Services at 1-800-944-9044**.

CLEAR HOSE TO COUPLER CONNECTION

- Place one of the supplied rubber washer (15) inside the hex nut on the one end of the clear hose (12) (beverage delivery line) and attach to keg coupler (11). Be sure to tighten the nut securely to prevent leakage. **DO NOT** over tighten. Over tightening may damage the gasket in the nut.

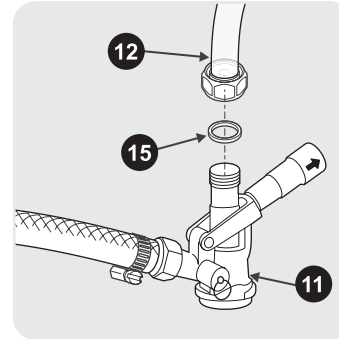

CLEAR HOSE TO DOOR PANEL CONNECTION

- Place the other supplied rubber washer (15) inside the hex nut on the other end of the clear hose (12) (beverage delivery line) and attach to the Faucet & Shank Assembly (6) protruding through the door panel. Be sure to tighten the nut securely to prevent leakage. **DO NOT** over tighten. Over tightening may damage the gasket in the nut.

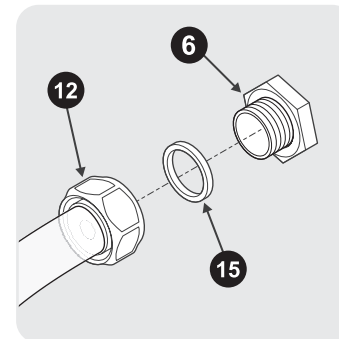

COUPLER TO KEG INSTALLATION

- Align locks on keg coupler (11) with housing on top of keg and push down on the keg coupler (11).
- Turn the tap head handle clockwise 1/4 turn. The tap head is now secured to the keg.
- Pull the tap handle out and push down to open the port in the keg.

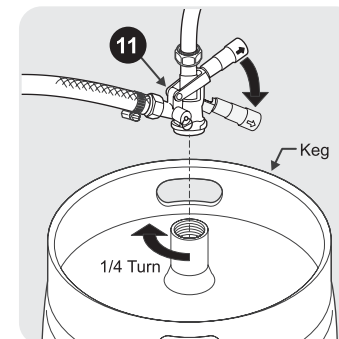

FIRST STEPS (continued)

DELIVERY HOSE PRESSURIZATION

- Open the CO₂ canister valve all the way by turning counterclockwise until it stops. This valve seals at both the fully open and fully closed positions. Failure to completely open or close the valve could result in premature loss of CO₂ pressure.
- Open the regulator shut-off valve by moving it to the 6 o'clock position.
- Check gauge pressure. Adjust the Regulator Adjustment Screw as necessary until the pressure reads between 12 to 14 psi. Tighten the Adjustment Lock Nut.

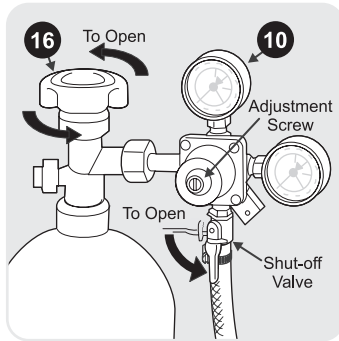

CO₂ CANISTER TO CABINET INSTALLATION

- Remove adjustable shelf from inside of cabinet.

NOTE

The adjustable shelf is intended for use with 1/4 keg or no keg. Reinstall shelf after keg installation if using 1/4 keg.

- Lift and place the CO₂ canister (16) with the CO₂ regulator (10) behind the shelf tower inside of the CO₂ canister bracket. It is important that the canister be kept in an upright position to operate efficiently.

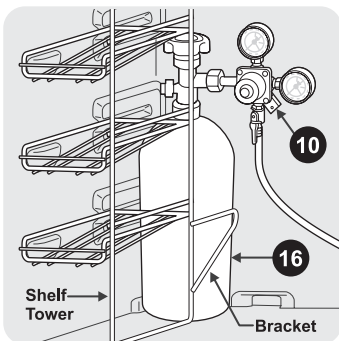

KEG TO CABINET INSTALLATION

- Place the keg on the Support Shelf and push back next to the CO₂ canister (16) (See TIPS ON INSTALLING KEG TO THE CABINET) inside the cabinet as shown.

NOTE

Shelf tower has been removed for clarity.

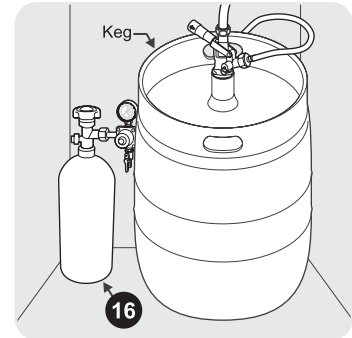

TIPS ON INSTALLING THE KEG TO THE CABINET

⚠ WARNING

SAFE KEG HANDLING

- Installing the keg to the cabinet is a two-person team effort. **NEVER** lift a full 1/2 keg alone. Doing so may cause severe injury.
- With the door fully open and the help of another person, lift the keg vertically on both sides until the keg is higher than the keg support shelf.
- Set the edge of the keg on top of the plastic protective plate located on top of keg support shelf. Slide the keg back until it is fully inside the cabinet.
- Care must be taken to avoid damage to the temperature control and shelf tower located in the cabinet.



NOTE

The above illustration does not show the tap installed for clarity of installation.

FIRST STEPS (continued)

DELIVERY HOSE ARRANGEMENT

- Insert the clear hose (12) (delivery hose) into the hose routing clips attached to the door and the cabinet. Follow the hose routing shown below depending on the door swing direction of your door.

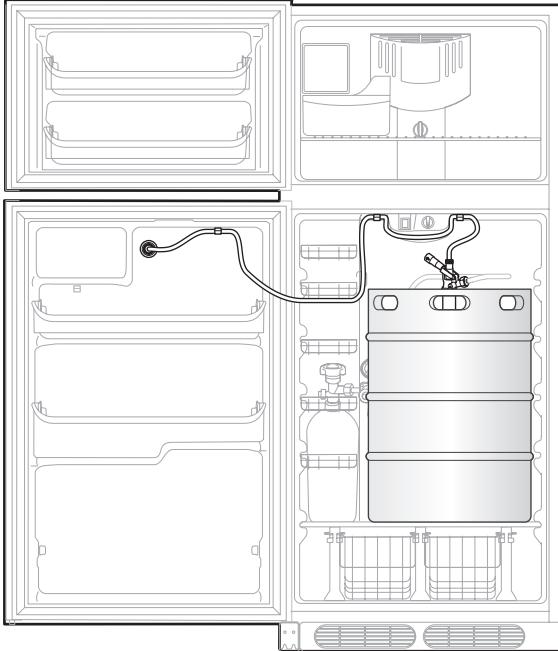

Left Hand Swing

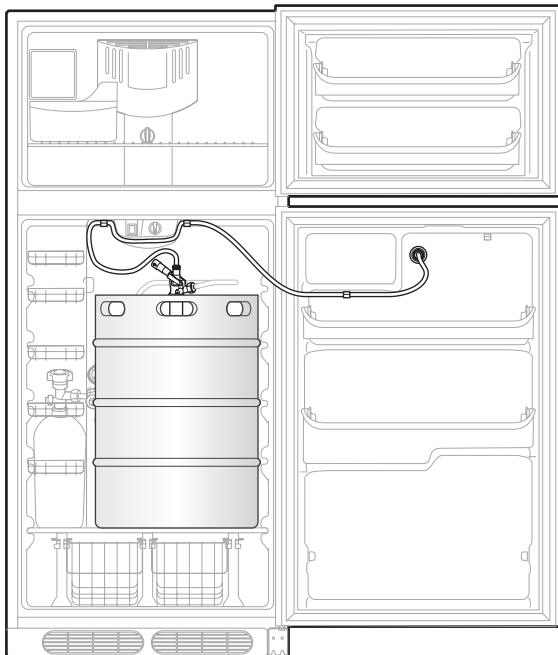

Right Hand Swing

CAUTION

Failure to route hoses properly may cause the hose to become kinked or caught in door.

OPERATING THE BEVERAGE CENTER

- Make sure that the beverage center is plugged in properly to a 115V, 60Hz AC only electrical outlet. Refer to Electrical Information on page 6.
- Make sure that the drip tray and sump are secured under the faucet.
- Start with a clean beverage glass that has been wetted in cold water. Place the glass at a 45° angle, one inch below the faucet. Do not let the glass touch the faucet. Open the faucet all the way.
- After the glass has reached half full, gradually bring the glass to an upright position.
- Let the remaining beverage run straight down the middle. This insures proper release of CO₂ by producing a ¾" to a 1" foam head.
- Close the faucet completely and quickly.

NOTE

It is normal to see condensation forming around the faucet. This condensation is caused by the temperature difference between the cold beverage and the inner surfaces of the faucet when beverage is being drawn through the line.

HOW TO REPLACE AN EMPTY CO₂ CANISTER

- Remove hoses from routing clips.
- Remove the keg, then remove CO₂ canister.
- Close the canister valve of the empty canister by turning clockwise until it stops.
- Close the regulator shut-off valve by moving it to the 9 o'clock position.
- Carefully remove regulator from the empty CO₂ canister by loosening the nut with an adjustable wrench. Check the condition of the gasket inside the nut and replace if necessary.
- Return canister to your local carbonic gas source for filling. (We suggest the customer look in the yellow pages under "Carbonic Gas". Sources of CO₂ vary from community to community but it is often available at welding supply stores and beverage distributors.)
- Remove dust cap from new canister nut, if any.
- With the canister valve still in closed position, reattach the regulator to the new canister using an adjustable wrench. Ensure the plastic washer is inside of the nut. Tighten nut until it feels snug but be careful not to over tighten as you will damage the gasket inside the stem nut.
- Check to make sure that the braided gas line hose is still securely attached to the regulator.
- Open the canister valve all the way by turning counter-clockwise until it stops. This valve seals at both the fully open and fully closed positions. Failure to completely open or close the valve could result in premature loss of CO₂ pressure.
- Open the regulator shut-off valve by moving it down to the 6 o'clock position.
- Check gauge pressure. Adjust the regulator adjustment screw as necessary until the pressure reads between 12 to 14 psi. Tighten the adjustment lock nut.
- Replace keg and route hose clips.

HELPFUL HINTS

PARTS OF A CO₂ REGULATOR

- (A) Low Pressure Gauge
- (B) Regulator Adjustment Screw
- (C) Adjustment Lock Nut
- (D) Shut-off Valve
- (E) CO₂ Nut (used to connect to CO₂ Canister)
- (F) High Pressure Gauge

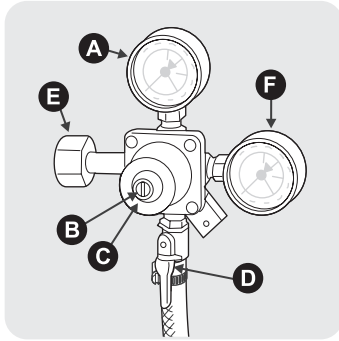

BEER STORAGE TEMPERATURE

- Draft beer is not pasteurized, so it must be kept cold, preferably at 38°F. Temperatures above 38°F may cause the beer to become wild, turn sour and cloudy.

RECOMMENDED KEG HANDLING

- Be sure the keg is cold when you purchase it.
- Transfer keg from place of purchase and install in beverage center in 2 hours or less.
- After the keg is installed in the beverage center, allow 24 hours for beverage to reach recommended temperature.
- If the keg is exposed to ambient temperatures longer than 2 hours, additional cooling time will be required before beverage will reach recommended temperature.

TYPICAL BEER SERVING EQUIVALENTS

	¼ Keg	½ Keg
Ounces	992	1984
Gallons	7 ¾	15 ½
Cases (12 oz. bottles)	3 ¾	6 ¾
Weight (full)	82.5 lbs. (approx.)	165 lbs. (approx.)

BEVERAGE COOLER EXTRA FEATURES

OPTIONAL CASTER KIT

If you'd like to make your beverage center so it can be rolled from room to room, there is an optional caster kit available from your authorized Frigidaire dealer or service center. Just ask for part number 5304451343 - Caster, Rail and Hardware Kit, which includes 2 fixed casters, 2 swivel casters, 2 caster support rails and mounting hardware.

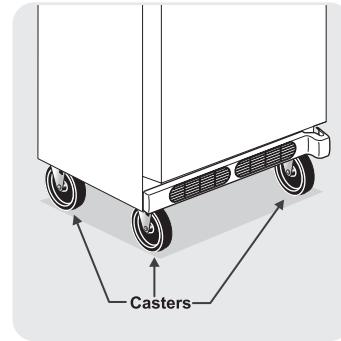

! CAUTION

DO NOT ATTEMPT TO MOVE OR RELOCATE THIS BEVERAGE CENTER WITH A KEG INSIDE.

ADJUSTABLE INTERIOR SHELVES

Adjustable interior shelf (P/N 241667701) can be used when ¼ keg is installed.

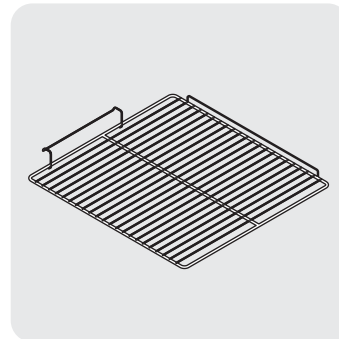

OPTIONAL ICE SERVICE

If the beverage center has an optional automatic ice maker installed, it will provide a sufficient supply of ice for normal use. However, during the initial startup of your beverage center, no ice will be produced during the first 24 hours of operation. Automatic ice makers are also optional accessories that may be installed in most models at any time. Call your local dealer for information.

The ice maker produces 2 to 5 pounds of ice every 24 hours depending on usage conditions. Ice is produced at a rate of 8 cubes every 80 to 160 minutes.

TURNING THE ICE MAKER ON

After the plumbing connections have been completed, the water supply valve must be opened. Place the ice container under the ice maker, pushing it as far back as possible. Lower the wire signal arm to its “down” or ON position. New plumbing connections may cause the first production of ice cubes to be discolored or have an odd flavor. These first cubes should be discarded until the cubes produced are free of discoloration and odd flavor.

NOTE

For more information on these operations, see *Normal Operating Sounds and Sights* section.

TURNING THE ICE MAKER OFF

To stop the ice maker, lift the wire signal arm until it clicks and locks in the “up” or OFF position. The ice maker also turns off automatically when the ice container is full. If your model has an adjustable freezer shelf, place the shelf in the lower position, so that the wire signal arm will hit the ice when the container is full.

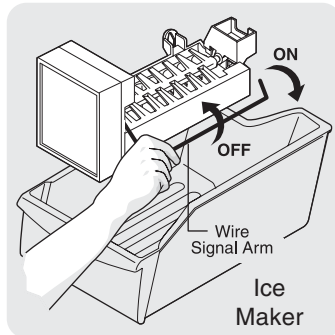

IMPORTANT

The ice maker is shipped with the wire signal arm in the ON position. To ensure proper function of your ice maker, hook up water supply immediately or turn ice maker OFF by lifting the wire signal arm until it clicks and locks in the UP position.

CAUTION

Chemicals from a malfunctioning softener can damage the ice maker. If the ice maker is connected to soft water, ensure that the softener is maintained and working properly.

ICE MAKER TIPS

- Ice cubes stored too long may develop an odd flavor. Empty the ice container and ensure that the wire signal arm is in its “down” or ON position. The ice maker will then produce more ice.
- Occasionally shake the ice container to keep ice separated.
- Keep the wire signal arm in its “up” or OFF position until the beverage center is connected to the water supply or whenever the water supply is turned off.
- The following sounds are normal when the ice maker is operating:
 - Motor running
 - Ice loosening from tray
 - Ice dropping into ice container
 - Running water
 - Water valve opening or closing
- Wash the ice container in warm water with mild detergent. Rinse well and dry.

CAUTION

DO NOT place the ice container in your dishwasher.

- Stop the ice maker when cleaning the freezer and during vacations.
- If the ice maker will be turned off for a long period of time, turn the water supply valve to the closed position.

For Service information on the ice maker refer to section “ICE MAKER” starting on page 53. For instructions on how to install an ice maker in the product, go to page 71, ICE MAKER INSTALLATION INSTRUCTIONS.

NORMAL OPERATING SOUNDS & SIGHTS

UNDERSTANDING THE SOUNDS YOU MAY HEAR

The new high-efficiency beverage center may make unfamiliar sounds. These are all normal sounds and soon will become familiar to you. They also indicate your beverage center is operating as designed. Hard surfaces, such as vinyl or wood floors, walls, and kitchen cabinets may make sounds more noticeable. Listed below are descriptions of some of the most common sounds you may hear, and what is causing them.

NOTE

Rigid foam insulation is very energy efficient, but is not a sound insulator.

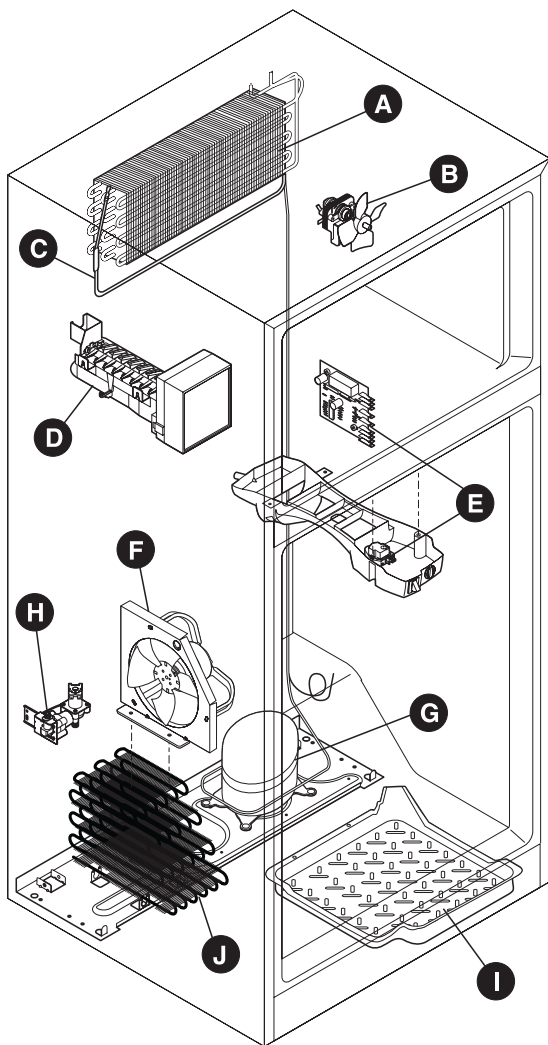

A. Evaporator

The flow of refrigerant through the evaporator may create a boiling or gurgling sound.

B. Evaporator Fan

You may hear air being forced through the beverage center by the evaporator fan.

C. Defrost Heater

During defrost cycles, water dripping onto the defrost heater may cause a hissing or sizzling sound. After defrosting, a popping sound may occur.

IMPORTANT

During the automatic defrost cycle, you may notice a red glow in the vents on the back wall of your freezer compartment. This is normal during the defrost cycle.

D. Automatic Ice Maker

If your beverage center is equipped with an automatic ice maker, you will hear ice cubes falling into the ice bin.

E. Cold Control & Defrost Timer or Automatic Defrost Control

These parts can produce a snapping or clicking sound when turning the beverage center on and off. The timer also produces sounds similar to an electric clock.

F. Condenser Fan

If condenser coils are located underneath your beverage center as shown in the drawing at the left, you have a condenser fan. You may hear air being forced through the condenser by the condenser fan.

G. Compressor

Modern, high-efficiency compressors operate much faster than older models. The compressor may have a high-pitched hum or pulsating sound.

H. Water Valve

If your beverage center is equipped with an automatic ice maker, you will hear a buzzing sound as the water valve opens to fill the ice maker during each cycle.

I. Drain Pan (Nonremovable)

You may hear water running into the drain pan during the defrost cycle. The drain pan is located on top of the compressor for air-cooled condensers (black coils on back of beverage center).

J. Condenser Coils (Fan-cooled models only)

May create minimal sounds from forced air.

CARE & CLEANING

The customer must keep the beverage center clean to prevent odor build-up. Wipe up any spills immediately and clean both sections at least twice a year. **Never** use any type of scouring pads, brushes, abrasive cleaners or strong alkaline solutions on any surface. **Do not** wash any removable parts in a dishwasher. **Always unplug the electrical power cord from the wall outlet before cleaning.**

CAUTION

- When moving the beverage center, pull straight out. Do not shift the beverage center from side to side as this may tear or gouge the floor covering. If the beverage center has an automatic ice maker, be careful not to move the beverage center beyond the plumbing connections. **DO NOT MOVE THE BEVERAGE CENTER WITH A KEG INSIDE.**
- Damp objects stick to cold metal surfaces. Do not touch refrigerated surfaces with wet or damp hands.
- Never use CHLORIDE to clean stainless steel.

NOTE

- Turning the beverage center temperature control to “0” turns off the compressor, but does not disconnect electrical power to the light bulb or other electrical components. To turn off power to your beverage center, you must unplug the power cord from the wall outlet.
- Do not use razor blades or other sharp instruments which can scratch the appliance surface when removing adhesive labels. Any glue left from tape or labels can be removed with a mixture of warm water and mild detergent, or, touch the glue residue with the sticky side of tape you have already removed. **Do not remove the serial plate.**

<h2>Care & Cleaning Chart</h2>		
Part	What To Use	Tips and Precautions
Interior/Door Liner	<ul style="list-style-type: none"> • Soap and water • Baking soda and water 	Use 2 tablespoons of baking soda in 1 quart of warm water. Be sure to wring excess water out of sponge or cloth before cleaning around controls, light bulb or any electrical part.
Door Gaskets	<ul style="list-style-type: none"> • Soap and water 	Wipe gaskets with a clean soft cloth.
Drawers/Bins	<ul style="list-style-type: none"> • Soap and water 	Do not wash any removable items (bins, drawers, etc.) in dishwasher.
Toe Grille	<ul style="list-style-type: none"> • Soap and water • Mild liquid sprays • Vacuum attachment 	Vacuum dust from front of toe grille. Remove toe grille (See illustration on page 7). Vacuum backside and wipe with sudsy cloth or sponge. Rinse and dry.
Exterior and Handles	<ul style="list-style-type: none"> • Soap and water 	Do not use commercial household cleaners, ammonia, or alcohol to clean handles.
Exterior and Handles (Stainless Steel Models Only)	<ul style="list-style-type: none"> • Soap and water • Ammonia • Stainless Steel Cleaners 	<p>⚠ CAUTION Never use CHLORIDE to clean stainless steel.</p> <p>Clean stainless steel front and handles with non-abrasive soapy water and a dishcloth. Rinse with clean water and a soft cloth. Wipe stubborn spots with an ammonia-soaked paper towel, and rinse. Use a non-abrasive stainless steel cleaner. These cleaners can be purchased at most home improvement or major department stores. Always follow manufacturer's instructions.</p> <p>NOTE: Always clean, wipe and dry with the grain to prevent cross-grain scratching. Wash the rest of the cabinet with warm water and mild liquid detergent. Rinse well, and wipe dry with a clean soft cloth.</p>
Condenser Coils (Fan-cooled models only)	<ul style="list-style-type: none"> • Condenser Cleaning Brush is available from your dealer. • Vacuum Cleaner 	No need to clean unless operating beverage center under particularly dusty or greasy conditions, or if there is significant pet traffic in your home. If cleaning is necessary, remove toe grille and use extended vacuum attachment and condenser cleaning brush to remove dust build-up from condenser coils (see item “J” in illustration on page 18 for location).
Condenser Coils (Air-cooled models only)	<ul style="list-style-type: none"> • Vacuum Cleaner 	Use the dusting tool attachment on your vacuum to remove dust build-up on the condenser coils (black tubes and wires) attached to the back of air-cooled beverage center only.
Defrost Water Pan	<ul style="list-style-type: none"> • Soap and water 	Some models have defrost water pan located on top of compressor at bottom rear of beverage center (see illustration on next page). Wipe water pan with damp cloth. NOTE: The defrost water pan is NOT removable.

CARE & CLEANING (continued)

PROPER CLEANING OF BEVERAGE CENTER DISPENSING SYSTEM

The beverage center's beverage dispensing system needs regular cleaning and sterilization in order to continue serving draft beer with its pure brewery flavor. It is recommended that the delivery lines be cleaned weekly and the entire delivery system cleaned before a new keg is attached. This is a relatively simple task. You will need the following parts to clean your unit's dispensing system. These parts are available at any draft beer dispensing equipment supplier or call Electrolux Consumer Services at 1-800-944-9044 for kit CK-1100, part # 5304443671.

- (A) 1 Quart Plastic Cleaning Bottle
- (B) Low Profile Hand Pump
- (C) Solid Brass Faucet Cleaning Attachment
- (D) 4 oz. Bottle of Cleaning Solution
- (E) Faucet Wrench
- (F) Faucet Cleaning Brush

- Mix one gallon of warm water with one ounce of the cleaning solution in a bucket.
- Remove the bottle cap and fill the bottle with the solution. Replace the cap. Do not discard the remaining solution.
- Before removing the delivery line from the tap or from the coupler, make sure the remaining beverage in the delivery line is blown out. This can be done by quickly opening and closing the regulator outlet valve.
- Remove the coupler from keg by rotating it counterclockwise.
- Remove the braided hose (gas line) from the coupler. Make sure the canister valve and regulator shut-off valve is shut off before removing the hose.
- Remove the faucet from the shank assembly by turning the threaded stainless steel collar clockwise using a faucet wrench.
- Disassemble the faucet parts and place in the cleaning solution bucket.
- Attach the brass attachment on the end of the cleaning hose to the faucet shank assembly by turning the stainless steel collar counterclockwise. Tighten the collar slightly.
- If the coupler has a shutoff, make sure it is in the open position.
- Place the keg coupler in the cleaning solution bucket and pump the cleaning solution through the beer line.
- Clean the faucet parts and keg coupler thoroughly using the faucet cleaning brush. Also, use the faucet cleaning brush to clean around the shank and coupling.
- Rinse all the parts with cool fresh water and reassemble the faucet.
- Detach the cleaning solution bottle from the faucet shank by turning the threaded stainless steel collar clockwise. Rinse the bottle with cool fresh water.
- Fill the bottle with fresh water and re-attach it to the faucet shank assembly. Pump the water through the delivery line (clear hose). Make sure the end of the line is in a bucket to collect rinse water.
- Disconnect the cleaner and reinstall the faucet to the shank by turning the collar counterclockwise using a faucet wrench and tightening it slightly. **DO NOT** over

tighten the collar.

- Reattach the braided hose (gas line) to the keg coupler and open both the canister valve and regulator shut-off valve.
- Reattach the keg coupler to the keg. Refer to Coupler to Keg Installation procedures.
- Remove the sump and drip tray from the door and clean thoroughly. Refer to Cleaning and Maintenance Guide.
- Reinstall the sump and drip tray to the door. Refer to Sump and Drip Tray Assembly Installation procedures.

NOTE

Read and follow the instructions that come with the cleaning kit before cleaning your beverage cooler.

NEVER CLEAN CONDENSER (SOME MODELS)

If the beverage center is equipped with a Never Clean condenser, there's no need to clean the condenser under normal operating conditions. If the beverage center is operated under particularly dusty or greasy conditions, or if there is significant pet traffic in your home, it may be necessary to periodically clean the condenser for maximum efficiency.

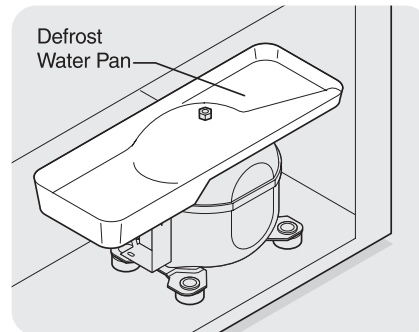

Defrost Water Pan (some models)

TROUBLESHOOTING GUIDE

TROUBLESHOOTING GUIDE	This list includes common occurrences that are not the result of defective workmanship or materials in this appliance.	
PROBLEM	CAUSE	CORRECTION

BEVERAGE CENTER OPERATION

Beverage center does not run.	<ul style="list-style-type: none"> • Beverage center is plugged into a circuit that has a ground fault interrupt. • Temperature control is in the "O" position. • Beverage center may not be plugged in, or plug may be loose. • House fuse is blown or circuit breaker tripped. • Power outage. 	<ul style="list-style-type: none"> • Use another circuit. If you are unsure about the outlet, have it checked by a certified technician. • See SETTING THE TEMPERATURE CONTROL section. • Ensure plug is tightly pushed into outlet. • Check/replace fuse with a 15 amp time-delay fuse. Reset circuit breaker. • Check house lights. Call local electric company.
Beverage center runs too much or too long.	<ul style="list-style-type: none"> • Room or outside weather is hot. • Beverage center has recently been disconnected for a period of time. • Doors are opened too frequently or too long. • Beverage center door may be slightly open. • Temperature control is set too low. • Beverage center gasket is dirty, worn, cracked, or poorly fitted. 	<ul style="list-style-type: none"> • It's normal for the beverage center to work harder under these conditions. • It takes 4 hours for the beverage center to cool down completely. • Warm air entering the beverage center causes it to run more. Open door less often. • See "DOOR PROBLEMS" section. • Adjust temperature control to a warmer setting. Allow several hours for temperature to stabilize. • Clean or change gasket. Leaks in the gasket will cause beverage center to run longer in order to maintain desired temperature.
Interior beverage center temperature is too cold.	<ul style="list-style-type: none"> • Temperature control is set too low. 	<ul style="list-style-type: none"> • Adjust temperature control to a warmer setting. Allow several hours for temperature to stabilize.
Interior beverage center temperature is too warm.	<ul style="list-style-type: none"> • Temperature control is set too warm. • Door is kept open too long or is opened too frequently. • Door may not be seating properly. • Beverage center has recently been disconnected for a period of time. 	<ul style="list-style-type: none"> • Adjust temperature control to a colder setting. Allow several hours for the temperature to stabilize. • Warm air enters the beverage center every time the door is opened. Open the door less often. • See "DOOR PROBLEMS" section. • It takes 4 hours for the beverage center to cool down completely.
Beverage center external surface temperature is warm.	<ul style="list-style-type: none"> • The external walls can be as much as 30° F warmer than room temperature. 	<ul style="list-style-type: none"> • This is normal while the compressor works to transfer heat from inside the beverage center.

SOUND AND NOISE

Louder sound levels whenever beverage center is on.	<ul style="list-style-type: none"> • Modern beverage centers have increased storage capacity and more stable temperatures. They require a high efficiency compressor. 	<ul style="list-style-type: none"> • This is normal. When the surrounding noise level is low, you might hear the compressor running while it cools the interior.
Longer sound levels when compressor comes on.	<ul style="list-style-type: none"> • Beverage center operates at high pressures during the start of the "ON" cycle. 	<ul style="list-style-type: none"> • This is normal. Sound will level off or disappear as the beverage center continues to run.
Fan runs when room temperature is below 45° F	<ul style="list-style-type: none"> • Exterior thermostat has activated the heater and fan. 	<ul style="list-style-type: none"> • This is normal.
Popping or cracking sound when compressor comes on.	<ul style="list-style-type: none"> • Metal parts undergo expansion and contraction, as in hot water pipes. 	<ul style="list-style-type: none"> • This is normal. Sound will level off or disappear as beverage center continues to run.
Bubbling or gurgling sound like water boiling.	<ul style="list-style-type: none"> • Refrigerant (used to cool beverage center) is circulating throughout the system. 	<ul style="list-style-type: none"> • This is normal.

TROUBLESHOOTING GUIDE

SOUND AND NOISE (CONT.)

Vibrating or rattling noise.	<ul style="list-style-type: none"> • Beverage center is touching the wall. 	<ul style="list-style-type: none"> • Move beverage center slightly away from the wall.
Snapping noise	<ul style="list-style-type: none"> • Temperature control turning beverage center on and off. 	<ul style="list-style-type: none"> • This is normal

WATER / MOISTURE / FROST INSIDE BEVERAGE CENTER

Moisture forms on inside of beverage center walls.	<ul style="list-style-type: none"> • Weather is hot and humid. • Door may not be seating properly. • Door is kept open too long or opened too frequently. 	<ul style="list-style-type: none"> • This is normal. • See “DOOR PROBLEMS” section. • Open the door less often.
--	--	---

WATER / MOISTURE / FROST OUTSIDE BEVERAGE CENTER

Moisture forms on outside of beverage center walls.	<ul style="list-style-type: none"> • Door may not be seating properly, causing the cold air from inside the beverage center to meet warm moist air from the outside. 	<ul style="list-style-type: none"> • See “DOOR PROBLEMS” section.
---	---	---

ODOR IN BEVERAGE CENTER

Unpleasant odors.	<ul style="list-style-type: none"> • Interior needs to be cleaned. 	<ul style="list-style-type: none"> • Clean interior with sponge, warm water, and baking soda.
-------------------	---	--

DOOR PROBLEMS

Door will not close.	<ul style="list-style-type: none"> • Beverage center is not level. 	<ul style="list-style-type: none"> • This condition can force the cabinet out of square and misalign the door. Level the unit.
----------------------	---	---

COMMON DRAFT PROBLEMS

<p>WILD BEER – Beer, when drawn, is all foam, or too much foam and not enough liquid beer.</p>	<ul style="list-style-type: none"> • Beer drawn improperly. • Creeping regulator. • Applied pressure is set too high. • Hot spots in line. • Tapped into a warm keg (should be 34°F ~ 38°F) • Center malfunctioning. • Faucet is in bad, dirty or worn condition. 	<ul style="list-style-type: none"> • Make sure faucet is opened all the way. Close quickly when done. • Replace regulator • Readjust regulator to a lower pressure until foam subsides. When pressure is properly set, you should be able to pour 10 oz. of beer in 5 seconds. • Make sure beer delivery line is not pinched and is fully inside the interior of the beverage center. • Wait until keg cools down to proper temperature. • Have beverage center serviced to return it to proper operating condition. • Thoroughly clean faucet with recommended cleaning kit. Replace all worn seals.
<p>FLAT BEER – Foamy head disappears quickly; beer lacks usual zestful brewery fresh flavor</p>	<ul style="list-style-type: none"> • Dirty glasses. • Applied pressure is set too low. • CO₂ is cut off. • Beer too cold. • Loose tap or vent connections. • Sluggish regulator. 	<ul style="list-style-type: none"> • Wash glasses using soap-free detergent. • Increase pressure until beer flows at a rate of 2 oz. per second. • Do not turn off CO₂ supply line to keg until keg is empty and ready to be removed. • Increase temperature of beverage center. See SETTING THE TEMPERATURE CONTROL section. • Check that coupler is properly installed in keg. • Replace regulator.
<p>CLOUDY BEER – When beer in glass appears hazy, not clear.</p>	<ul style="list-style-type: none"> • Frozen or near frozen beer. • Unrefrigerated beer for long periods of time. 	<ul style="list-style-type: none"> • Return keg to place of purchase and exchange for one that has been properly refrigerated. • Exchange keg for fresh one.
	<ul style="list-style-type: none"> • Dirty glasses. • Dirty faucet. • Unrefrigerated foods placed on top of cold keg. 	<ul style="list-style-type: none"> • Wash glasses using soap-free detergent. • Clean faucet with recommended cleaning kit. • Remove items from atop keg and place in a separate refrigerator.

ELECTRICAL COMPONENTS

ELECTRICAL GROUNDING

All refrigerators are equipped with a power supply cord incorporating a three-prong grounding plug and a ground wire which is attached to the refrigerator cabinet for protection against shock hazard. Each electrical component is either cabinet mounted or connected through a ground wire to the cabinet to complete the ground. Certain components, such as defrost timers, may be double insulated and do not require a ground wire.

Ensure that the electrical wall receptacle is of the three prong type and is properly grounded in accordance with the National Electrical Code and/or local codes.

COMPRESSOR ELECTRICAL COMPONENTS AND CIRCUITS

The new series of very high efficiency compressor is equipped with all new electrical components consisting of a solid state PTC relay with a thermally operated overload protector, and a run capacitor. (See Figure C1)

Solid State Relay

The solid state relay has no moving parts. It consists of a PTC resistor mounted in a plastic case with appropriate terminals. PTC (Positive Temperature Coefficient) simply denotes a resistor which increases in resistance as its temperature is increased. The self-heating PTC resistor used in the solid state relay has the unique characteristic of changing from low to very high resistance very abruptly, thus serving as an ON-OFF switch. (See Figure C3)

The solid state relay plugs directly onto the compressor start and run terminals. (See Figure C2) Relay terminals 1, 2, and 5 are connected within the relay, as are terminals 3 and 6.

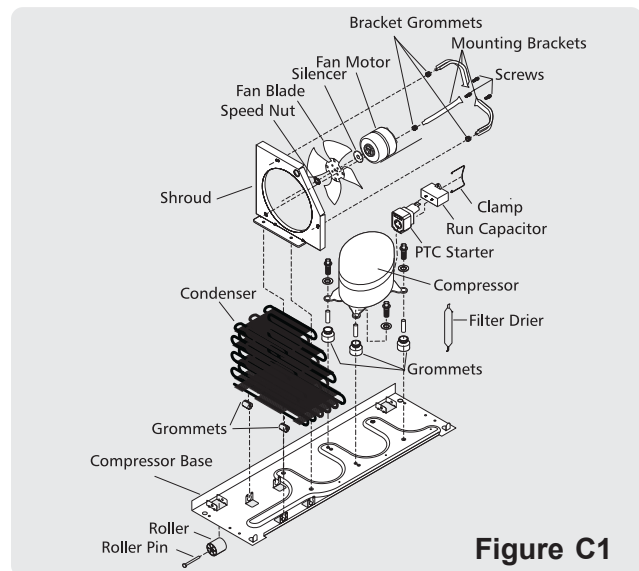

Figure C1

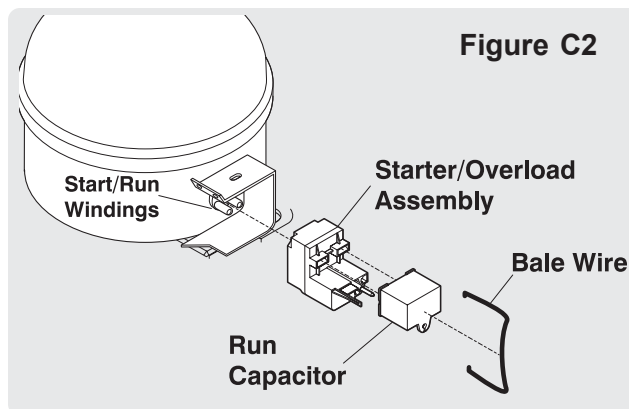
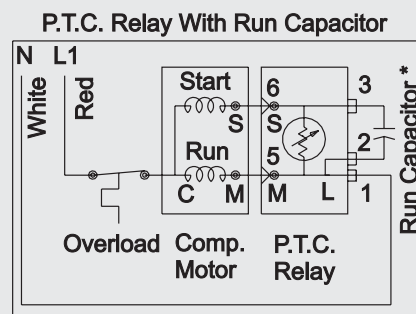

Figure C2

A run capacitor is connected to relay terminals 2 and 3, so it is connected in parallel with the PTC resistor. One side of the 120 VAC power is connected to relay terminal 1. The other side of the line is connected to the overload protector. (See figure C3.)



* Capacitor Is Only Used With Some P.T.C. Models.

Figure C3

NOTE: There are two Exploded View Diagrams (Cabinet and System) at the end of this section, pages ??, to assist you in troubleshooting.

To Check/Replace Relay

1. Disconnect electrical supply to refrigerator.
2. Remove bale wire holding relay to compressor. (See Figure C2)
3. Remove relay assembly from compressor. (See Figure C2)
4. Use small, flat-bladed screwdriver to disconnect leads to relay assembly.
5. Use flat-bladed screwdriver to gently pry capacitor from relay assembly.
6. Use ohmmeter to check resistance between terminals 5 and 6. Resistance should be 3 to 12 ohms, at normal room temperature. Shorted relay will read 0 ohms. Open relay will read very high or infinite resistance.

7. If ohm readings are out of range, replace relay.
8. Reverse this procedure to reassemble.

NOTE: When replacing leads to the PTC relay, ensure that locking tabs snap into terminal.

Overload Protector

The overload protector is completely thermally operated. It will open from excessive heat or current. Unlike prior overloads, the internal bimetal is not self-heating, and is not a part of the electrical circuit. The overload has a small built-in coil heater that is in series with the compressor start and run windings (See Figure C3).

To Check/Replace Overload Protector

1. Disconnect electrical supply to refrigerator.
2. Remove bale wire holding relay to compressor.
3. Remove relay assembly from compressor.
4. Use flat-bladed screwdriver to gently pry capacitor from relay assembly.
5. Use small, flat-bladed screwdriver to disconnect leads to relay assembly. (Note: On some models you will have to remove bale wire and cover, to gain access to relay and overload protector.)
6. Use ohmmeter to check resistance between tab terminal and female pin terminal. Overload protector should have less than 1 ohm of resistance at normal room temperature.
7. If ohm readings are out of range, install new Starter/Overload Assembly. (See Figure C2)
8. Reverse this procedure to reassemble.

NOTE: When replacing leads to the PTC Relay, ensure the locking tabs snap back into the terminal.

Run Capacitor

The run capacitor has permanently attached terminals which are connected to relay terminals 2 and 3.

NOTE: Some models are not equipped with a run capacitor

To Check/Replace Run Capacitor

1. Disconnect electrical supply to refrigerator.
2. Remove bale wire holding relay to compressor.
2. Use small, flat-bladed screwdriver to disconnect leads to relay assembly.
3. Use flat-bladed screwdriver and gently pry capacitor from relay assembly.
4. Discharge capacitor by shorting across terminals with 500K (1 watt) resistor for one minute.
5. Use ohmmeter set on the “**Ohms times 1000**” scale (if available), to check resistance across capacitor wire terminals.

- Needle should jump towards zero ohms and quickly move back to infinity.
- If needle does not move, capacitor is open.
- If needle reads constant value at or near zero ohms, capacitor is shorted out.
- If needle jumps toward zero and then moves back to constant high resistance (not infinity), capacitor has high resistance leak.

6. If ohm readings are out of range, replace capacitor.
7. Reverse procedures to reassemble.

Compressor Start Circuit

When the compressor circuit is first energized, the solid state relay has low resistance (3-12 ohms), and both the run and start windings are energized to start the compressor. The run capacitor is being bypassed by the relay, and it has a minor function during compressor starting (See Figure C4).

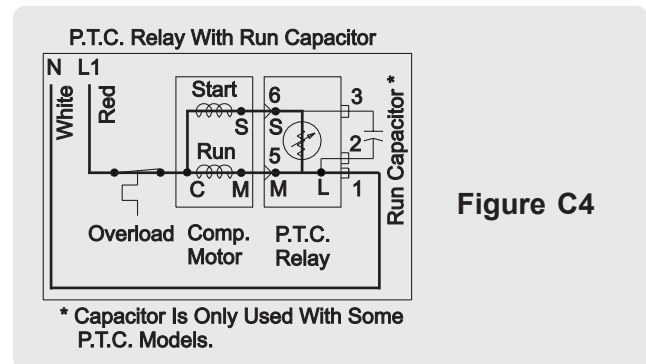

Figure C4

Compressor Run Circuit

When the self-heating solid state relay has reached sufficient temperature, it will abruptly change from low resistance (3-12 ohms) to very high resistance (10-20K ohms) and, in effect, switch off the start windings.

The relay no longer shunts the run capacitor. The run capacitor is now in series with the start windings. The only purpose of the run capacitor is to improve compressor operating efficiency, which it does by correcting the power factor of the compressor motor (See Figure C5).

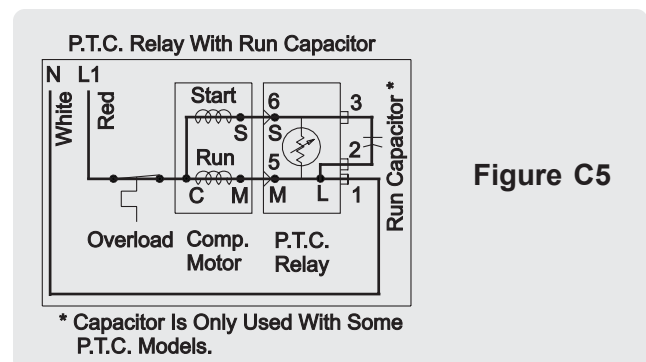

Figure C5

COMPRESSOR OPERATING CHARACTERISTICS

- When the compressor electrical circuit is energized, the start winding current causes the relay to heat and switch off the start winding circuit.

NOTE: The relay will switch off the start winding circuit even though the compressor has not started (as when attempting to restart after momentary power interruption).

- The overload protector is designed and calibrated to open the compressor electrical circuit with locked rotor run winding current only.
- With an open relay, the compressor will not start since there is little or no current to the start windings. The overload protector will open due to high locked rotor run winding current.
- With a shorted relay or capacitor, the compressor will start, and the overload protector will open.
- With an open or weak capacitor, the compressor will start and run. However, the compressor will be operating at reduced efficiency of energy usage.
- If the compressor casing gets too hot, it will shut down on the overload. After the compressor has cooled down, the overload will reset and the compressor will restart.
- In rear mounted condensers, the overload will cycle the compressor on and off if the refrigerator is set in so tight that the air can't circulate around the condenser. In air cooled condensers, the overload will cut the unit off if the condenser becomes blocked or the fan motor stops running.

COMPRESSOR ELECTRICAL CHECK

If the compressor will not run, make a voltage check across the power lead terminals on the PTC Relay and the Overload Protector. (See Figure C5.)

The voltmeter should show line voltage if the thermostat knob is in normal operating position and not in the OFF position. If this check does not show a live circuit, the control thermostat and defrost timer wiring should be checked for loose and/or broken connections.

A control thermostat check can be made by using a piece of wire as a temporary bridge across two thermostat terminals. If the compressor starts and runs with the bridge, the control thermostat is at fault and should be replaced.

If the voltage check shows power supply at the PTC Relay terminals, use a test cord to check the compressor.

If the compressor does not start and run with the test cord, check the line voltage to see if there is more than 10% variation from the rated voltage. If voltage is correct and the compressor will not start and run, replace the compressor.

If the compressor starts and runs with the test cord, replace the PTC Relay.

CONTROL THERMOSTAT

Automatic Defrost Models

The control thermostat is a variable cut-in type. When the thermostat knob is changed from one setting to another, both cut-in and cut-out temperature change. The degrees of temperature change are determined by the knob setting.

Temperature Control Mounting

The temperature control is mounted in a one-piece plastic control housing. The sensing element is attached to the projection on the bottom of the housing, with a single bend (See Figure C6).

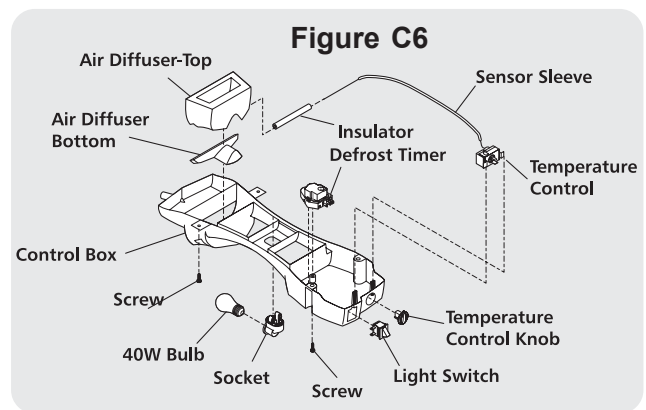

To Remove Temperature Control

1. Disconnect electrical supply to refrigerator.
2. Remove four screws securing housing to top of refrigerator compartment.
3. Unplug moxex connector.
4. Remove Temperature Control knob.
5. To remove Temperature Control from housing, pull back on two tabs and lift Temperature Control out. (See figure C7.)

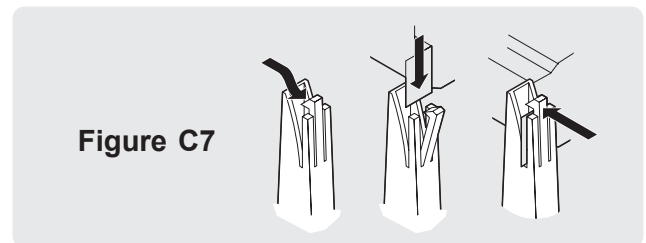

6. Disconnect three terminal lugs connected to control. They may be tight so use needle nose pliers to loosen them from terminals to prevent damaging terminals and lugs.
7. Remove top of Air Diffuser. (It is in there kind of snug, so be careful not to damage it while removing it.)
6. Remove control bulb from housing.
7. Reverse this procedure to complete repairs.

To Remove Refrigerator Light Socket

1. Disconnect electrical supply to refrigerator.
2. Remove four screws securing housing to top of refrigerator compartment. (See Figure C6.)
3. Unplug mox connector.
4. Unscrew light bulb.
5. Disconnect two wires to light socket. (Yellow/Red and Blue wires)
6. Squeeze in on tabs on light socket and push through Control Box.
6. Reverse procedure to complete repairs.

To Remove Freezer Light Socket (See Figure C8)

1. Disconnect electrical supply to refrigerator.
2. Remove freezer section shelves and baskets.
3. Remove two screws securing ice cube tray holder or ice maker (some models).
4. Disconnect ice maker mox plug from wiring harness connector mounted on back freezer wall in upper left hand corner (some models).
5. Remove fan access cover by pressing in on both sides (top and bottom) of access cover and pull forward.
6. Remove light shield by pressing in on tab on bottom of shield and pulling forward.
7. Disconnect three wires to lamp socket. (Yellow/Red and two piggybacked Blue wires)
8. Push in on tabs on light socket and push through coil cover.
6. Reverse procedure to complete repairs.

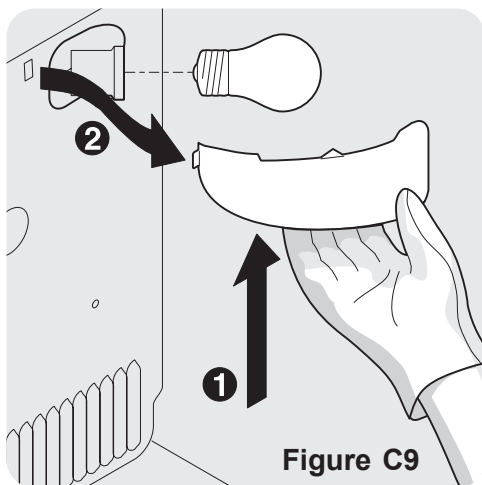

Figure C9

LIGHT SWITCH

The light switch is a door activated, single-pole, single-throw switch (**SPST**). (See Figure C10)

When the door is closed, the light circuit is open (OFF). Push on terminal connectors secure the wiring harness leads to the switch terminals.

To replace the switch, pry the switch out of its mounting, disconnect the wire leads, and replace.

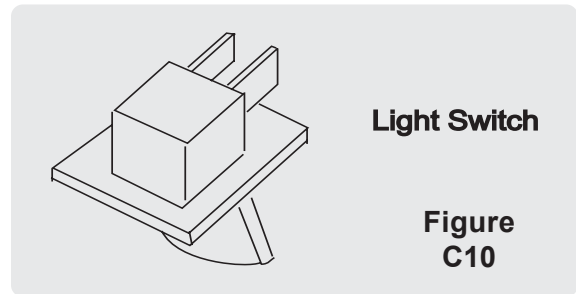

DAMPER CONTROL

The Damper Control regulates the freezer compartment temperature. The Damper Control consists of the Freezer Control Knob and Damper.

When the Freezer Control Knob is moved from a **WARMER** to a **COLDER** setting, the Damper moves, keeping more air generated by the Freezer Fan Assembly inside the freezer compartment.

When the Freezer Control Knob is moved from a **COLDER** to a **WARMER** setting, the Damper moves to allow more air into the refrigerator section.

PERIMETER HOT TUBE / MULLION HEATER

To reduce the possibility of condensation forming on the exterior of the cabinet and between doors in high humidity areas, units are equipped with a perimeter hot tube and/or a center mullion heater.

The perimeter hot tube, which is part of the refrigeration system, is used instead of an electric perimeter heater. Refer to Refrigeration Section E for details.

EVAPORATOR FAN & MOTOR ASSEMBLY

The fan and motor assembly is located behind the freezer compartment air duct directly above the evaporator in the freezer compartment.

The fan is a suction type, pulling air up through the evaporator and blowing it through an air duct behind the liner into the food compartment through the freezer control baffle.

The freezer compartment fan motor is wired in series with the control thermostat and the contacts of the defrost timer, and operates when the control thermostat contacts are closed, except during the defrost cycle.

On current production models, the fan blade is not adjustable and is designed to be pressed onto the motor shaft until it bottoms out against the stop at the front of the fan blade.

To Remove Freezer Fan Motor (See Figure C11)

NOTE: When replacing the fan blade, press the blade onto the motor shaft until the blade bottoms out on the shaft.

1. Disconnect electrical supply to refrigerator.
2. Remove freezer section shelves and baskets.
3. Remove two screws securing ice cube tray holder or ice maker (some models).
4. Disconnect ice maker molex plug from wiring harness connector mounted on back freezer wall in upper left hand corner (some models).
5. Remove fan access cover by pressing in on both sides (top and bottom) of access cover and pull forward.
6. Remove Light Shield by pressing in on tab on bottom of shield and pulling forward. Remove light bulb.
7. Remove four screws securing evaporator coil cover.
8. Press in on tabs of wiring harness connector and push through opening in fan access cover.
9. Disconnect four wires from evaporator fan motor. (Green/Yellow, Red and two piggybacked Blue wires)
10. Disconnect three wires to lamp socket. (Yellow/Red and two piggybacked Blue wires)
11. Remove Evaporator Coil Cover.
12. Remove two screws securing fan motor assembly to evaporator coil cover.
13. Remove fan blade. (It pulls straight off.)
14. Remove two screws securing front motor bracket to rear mounting bracket.
15. Check resistance of motor by reading across two terminals on coil. Resistance should read high on R1 scale. If not, replace motor.
16. Reverse procedure to complete repairs.

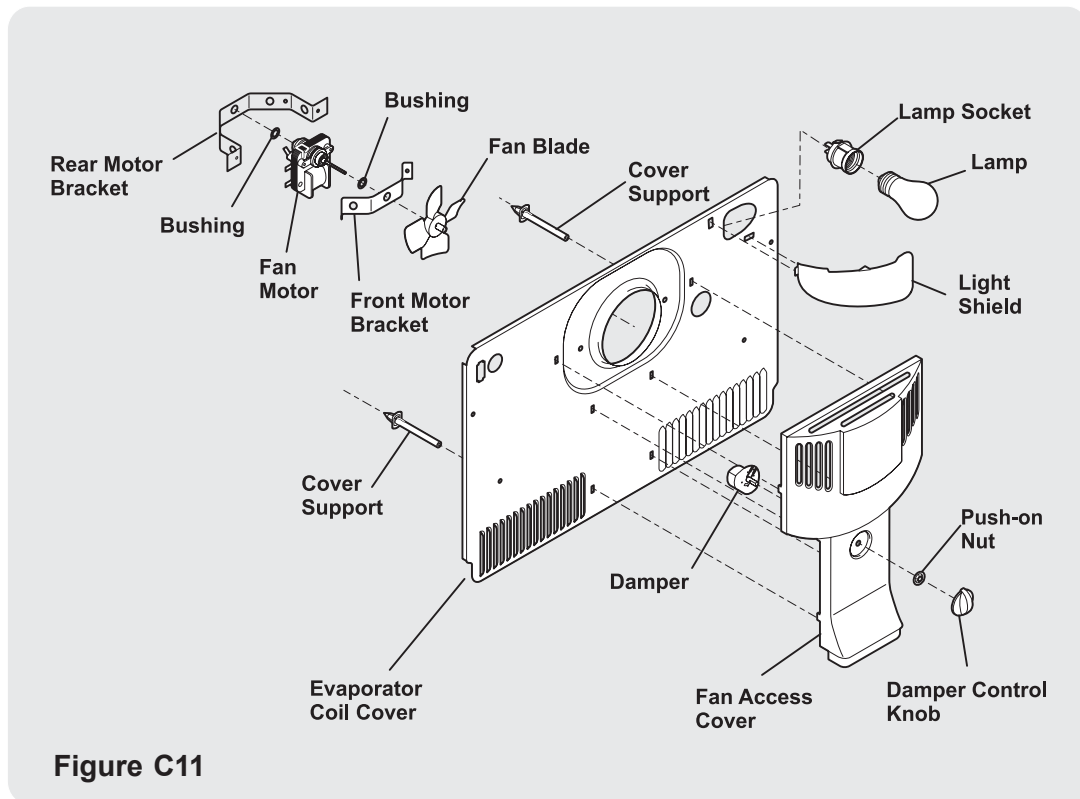

Figure C11

DEFROST TIMER (MECHANICAL)

The timer motor is energized during the defrost and compressor run cycles. The timer motor turns an internal cam. The cam opens and closes the electrical circuits to the compressor, evaporator fan motor, condenser fan motor, and defrost heater.

To Remove Defrost Timer

1. Disconnect electrical supply to refrigerator.
2. Remove four screws securing housing to top of refrigerator compartment.
3. Unplug moxex connector coming from top of cabinet.
4. Unplug connector to Defrost Timer. It may be very snug. Use pliers to pull it loose from timer.
5. Remove two screws securing timer to control housing. (See Figure C12.)
6. Reverse procedure to complete repairs.

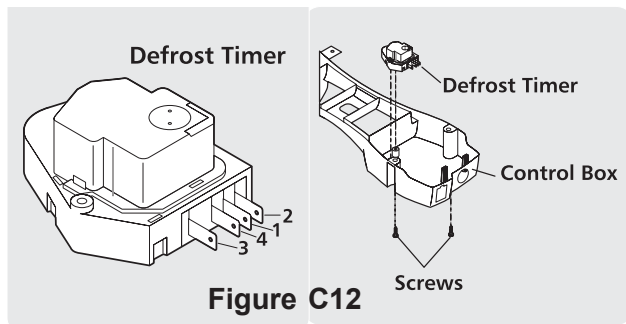

Figure C12

To Check Defrost Timer

NOTE: The Defrost Timer contains a capacitor in series with the motor. Use a 10K ohm scale and test as a capacitor.

1. Disconnect electrical supply to refrigerator.
2. Remove defrost timer.
3. With timer in compressor run cycle, check continuity from terminals 1 and 4.
4. Rotate timer knob until a click is heard or infinite resistance is present.
5. With timer in defrost cycle, continuity should be present between terminals 1 and 2.
6. With ohmmeter, check resistance at, or between terminals 1 and 3. (Refer to data sheet.)

To check the mechanical operation, connect the timer to the multiconnector. With 120 VAC present at terminals 1 and 3, the timer knob will rotate (check after ten minutes).

DEFROST THERMOSTAT

The defrost thermostat is a temperature sensing device. Wired in series with the defrost timer and the evaporator defrost heater, it senses the rise in evaporator temperature during a defrost cycle and cycles the defrost heater off after all frost is melted. It is calibrated

to permit a defrost cycle only when the temperature is below a preset temperature. The contacts in the defrost thermostat are set to open at 47°F and close at 25°F.

To Remove The Defrost Thermostat

1. Disconnect electrical supply to refrigerator.
2. Remove freezer shelves, ice bucket, ice trays and baskets.
3. Remove Ice Maker/Ice Maker tray holder (2 screws) in place on left wall of freezer.
4. Remove evaporator fan access cover (1 screw).
5. Remove evaporator coil cover (4 screws).

NOTE: Ensure that you disconnect the green ground wire connected to the evaporator coil cover on the bottom left hand corner.

6. Disconnect two leads to thermostat which is mounted to upper left corner of evaporator.
7. Remove thermostat from evaporator.
8. Reverse procedure to complete repairs.

To Test The Defrost Thermostat

1. Measure resistance across two thermostat leads. At room temperature, resistance should be infinity. Contacts are open.
2. Place couple of ice cubes on sides of thermostat. After few seconds, thermostat should reset.
3. Measure resistance again. This time, reading should be 0. Contacts have closed.
4. If you get resistance readings that differ from those listed in this procedure, replace defrost thermostat. Contacts are probably burnt.

DEFROST HEATER

The defrost heater is a radiant “U” shaped resistance heater, rated at 600 watts on some models. (See the Service Data Sheet for correct wattage.) The defrost heater is wired in series with the defrost thermostat and contacts 2 to 1 of the defrost timer. The defrost heater is energized during that period of the cycle when the defrost thermostat contacts are closed.

The length of time the heater is energized depends on the amount of frost accumulation on the evaporator.

NOTE: During the automatic defrost cycle, there will be a red glow in the vents on the back wall of the freezer compartment. This is normal during the defrost cycle.

How To Remove The Defrost Heater (See Figure C13)

1. Disconnect electrical supply to refrigerator.
2. Remove freezer shelves, ice bucket, ice trays and baskets.
3. Remove Ice Maker/Ice Maker tray holder (2 screws) in place on left wall of freezer.

4. Remove evaporator fan access cover (1 screw)

5. Remove evaporator coil cover (4 screws).

NOTE: Ensure that you disconnect the Green/
Yellow ground wire connected to the drain trough.

6. Disconnect leads (2) to defrost heater.

7. Pull evaporator away from insulator so bottom of
evaporator is free and pointing towards you.

NOTE: The defrost heater is positioned in between
the evaporator coils. It is a very snug fit.

8. Grab heater from bottom and pull free of evaporator.
It is very snug so you will need to use a little force.

9. Check resistance of defrost heater using multimeter.
(Refer to data sheet on page 31)

10. Replace defrost heater if resistance readings are
out of range.

11. Reassemble in reverse order.

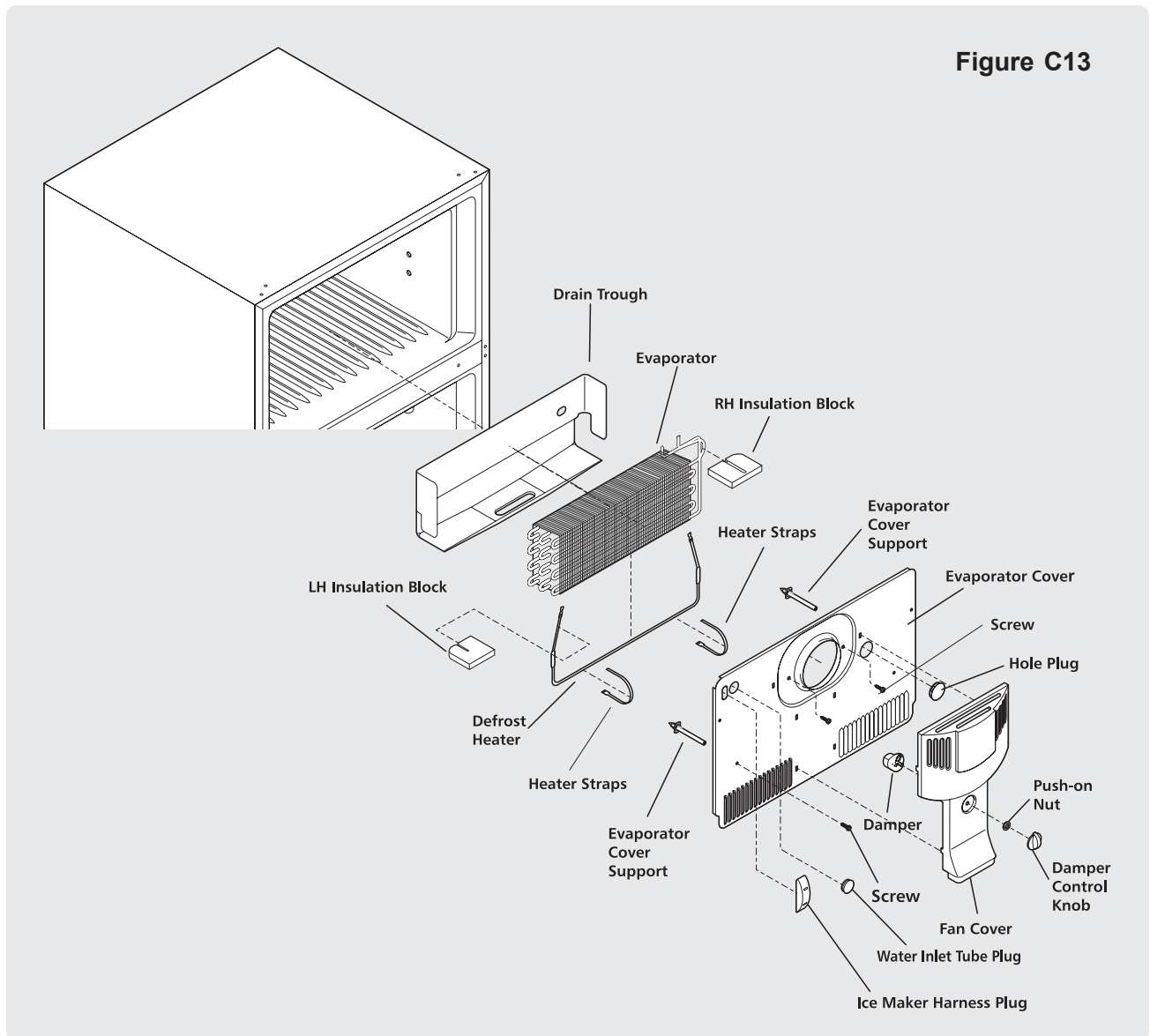

PERFORMANCE DATA NO LOAD AND NO DOOR OPENINGS AT MID-POINT CONTROL SETTING				
Capacitor Run or Induction Run	65°F (18°C) Ambient	90°F (32°C) Ambient		
Operating Time	25 to 35%	45 to 55%		
Freezer Temperature	2° to 8°F -17° to -13°C	0° to 5°F -18° to -15°C		
Refrigerature Temperature	35° to 40°F 2° to 4°C	35° to 40°F 2° to 4°C		
Low Side Pressure (cut-in)	8 to 16 psig 55 to 110 kPa	8 to 16 psig 55 to 110 kPa		
Low Side Pressure (cut-out)	1 to 4 psig 7 to 28 kPa	1 to 4 psig 7 to 28 kPa		
High Side Pressure (Last 1/3 of cycle)	110 to 120 psig 758 to 827 kPa	150 to 175 psig 1034 to 1207 kPa		
Wattage (Last 1/3 of cycle)	140 to 185	140 to 185		
Amps (Running)	1.1 to 1.6	1.1 to 1.6		
Base Voltage	115 VAC (127 VAC Max)	115 VAC (127 VAC Max)		
DEFROST SPECIFICATIONS				
Cabinet Size	Thermostat		Heater	
	Cut-in	Cut-out	Watts	Ohms
18' & 21'	25°F -4°C	47°F 8°C	375	35
14', 15' & 17'	25°F -4°C	47°F 8°C	325	41
Mechanical Timer - Defrost 30 Minutes Every 10 Hours of Compressor Run Time Electronic Timer (ADC) Defrost Up To 24 Minutes Every 6 - 72 Hours of Compressor Run Time				
CONDENSER FAN MOTOR				
Watts	RPM	Amps		
2.3	1100 CW Opposite Shaft	.15 Running		
ICE MAKER SPECIFICATIONS				
Electrical	115 VAC (127 VAC Max)	60 Hertz		
Thermostat	Opens at 48°F (9°C)	Closes at 15°F (-9°C)		
Heater Wattage	165			
ICE MAKER CONNECTOR PLUG CONNECTIONS				
Wire Number	Wire Color	Connects to:		
1	Green/Yellow	Ground		
2	Yellow	Water Valve		
3	Black	Line		
4	Lt. Blue	Neutral		

ICE MAKER INFORMATION Test Cycling

Remove cover by inserting screwdriver in notch at bottom and prying cover from housing. Use screwdriver to rotate motor gear counterclockwise until *Holding Switch* circuit is completed. All components of ice maker should function to complete the cycle.

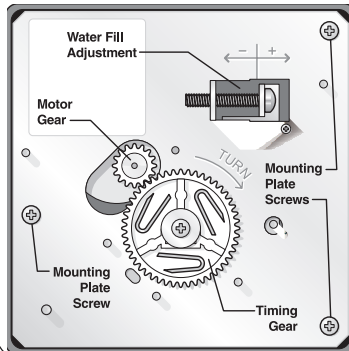

Water Fill Volume

The water fill adjustment screw will change the fill time. One full turn is equal to 20cc (.68 oz.). The correct fill is 95 to 105cc (3.2 to 3.6 oz.). When a water valve is replaced, the fill volume must be checked.

SERVICE DATA SHEET

STANDARD - AUTO-
MATIC DEFROST

P/N: 240379017

IMPORTANT SAFETY NOTICE

The information provided herein is designed to assist qualified repair personnel only. Untrained persons should not attempt to make repairs due to the possibility of electrical shock. Disconnect power cord before servicing.

IMPORTANT

If any green grounding wires are moved during servicing, they must be returned to their original position and properly secured.

CAUTION: All electrical parts and wiring must be shielded from torch flame. Do not allow torch to contact insulation; it will char at 200°F and flash ignite (burn) at 500°F. Excessive heat will distort the plastic liner.

NOTE: Some products come equipped with an Electronic Defrost Control. To initiate defrost, depress the fresh food light switch 5 times in 6 seconds (light bulb must be working). To terminate defrost, depress the fresh food light switch 5 times in 6 seconds.

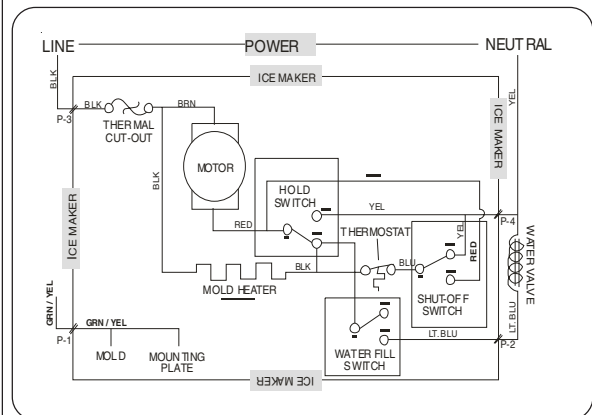
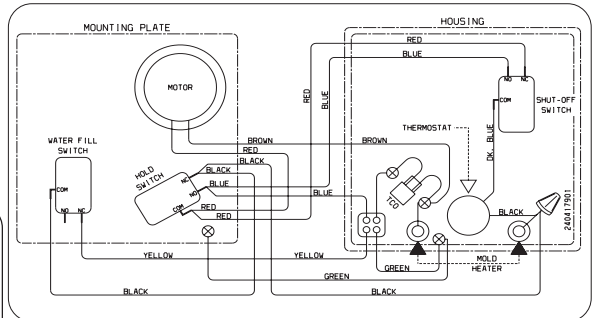

LADDER SCHEMATIC

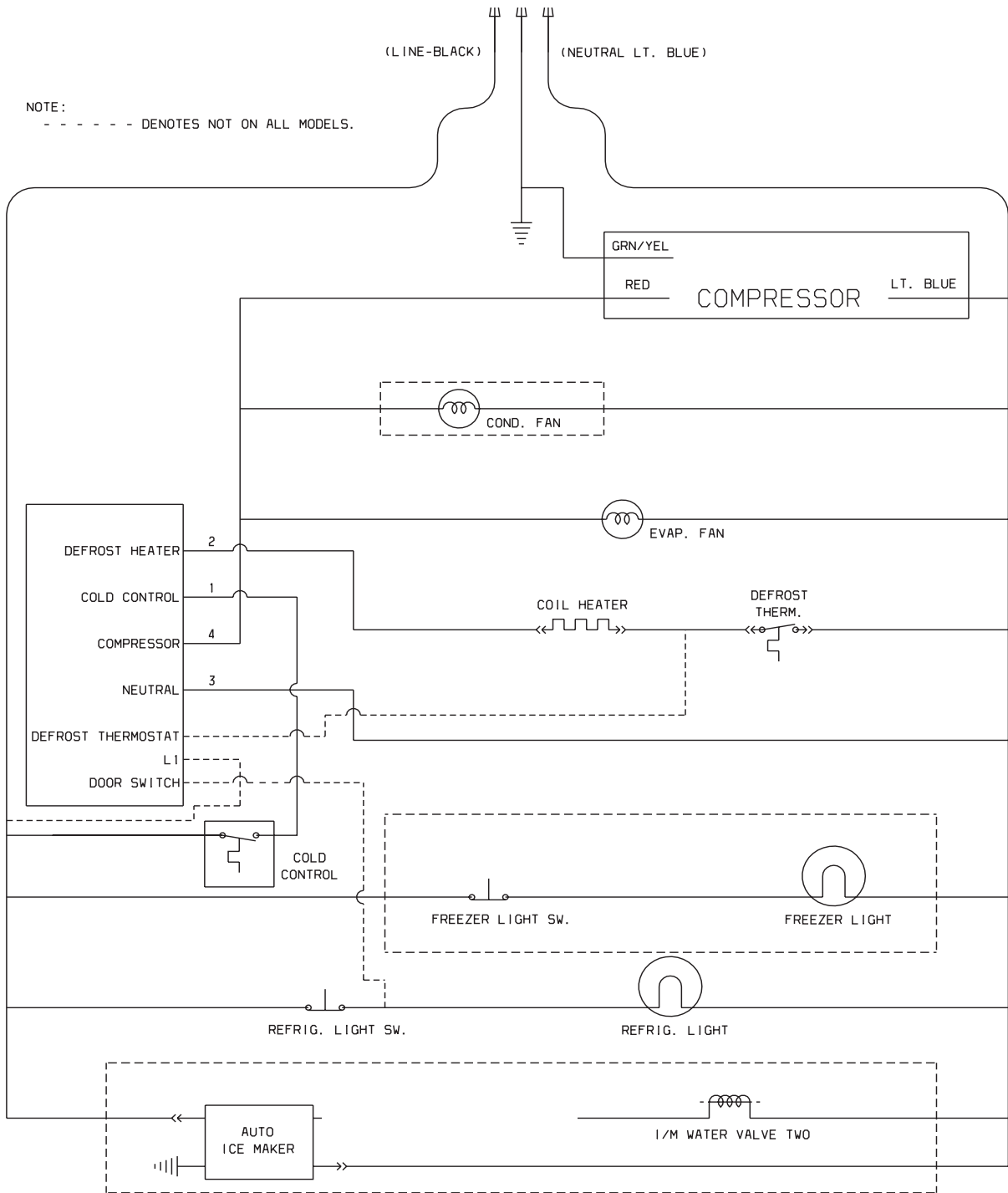

COMPRESSOR WIRING

Induction Run Compressor with Relay

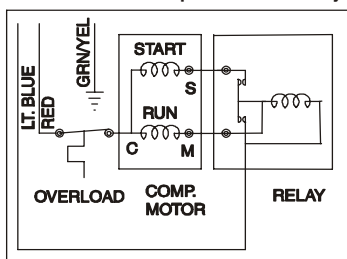

P.T.C. STARTER WITH RUN CAPACITOR

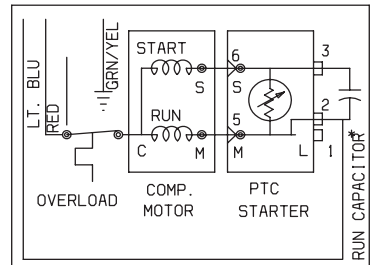

* CAPACITOR IS ONLY USED WITH SOME P.T.C. MODELS.

WIRING DIAGRAM

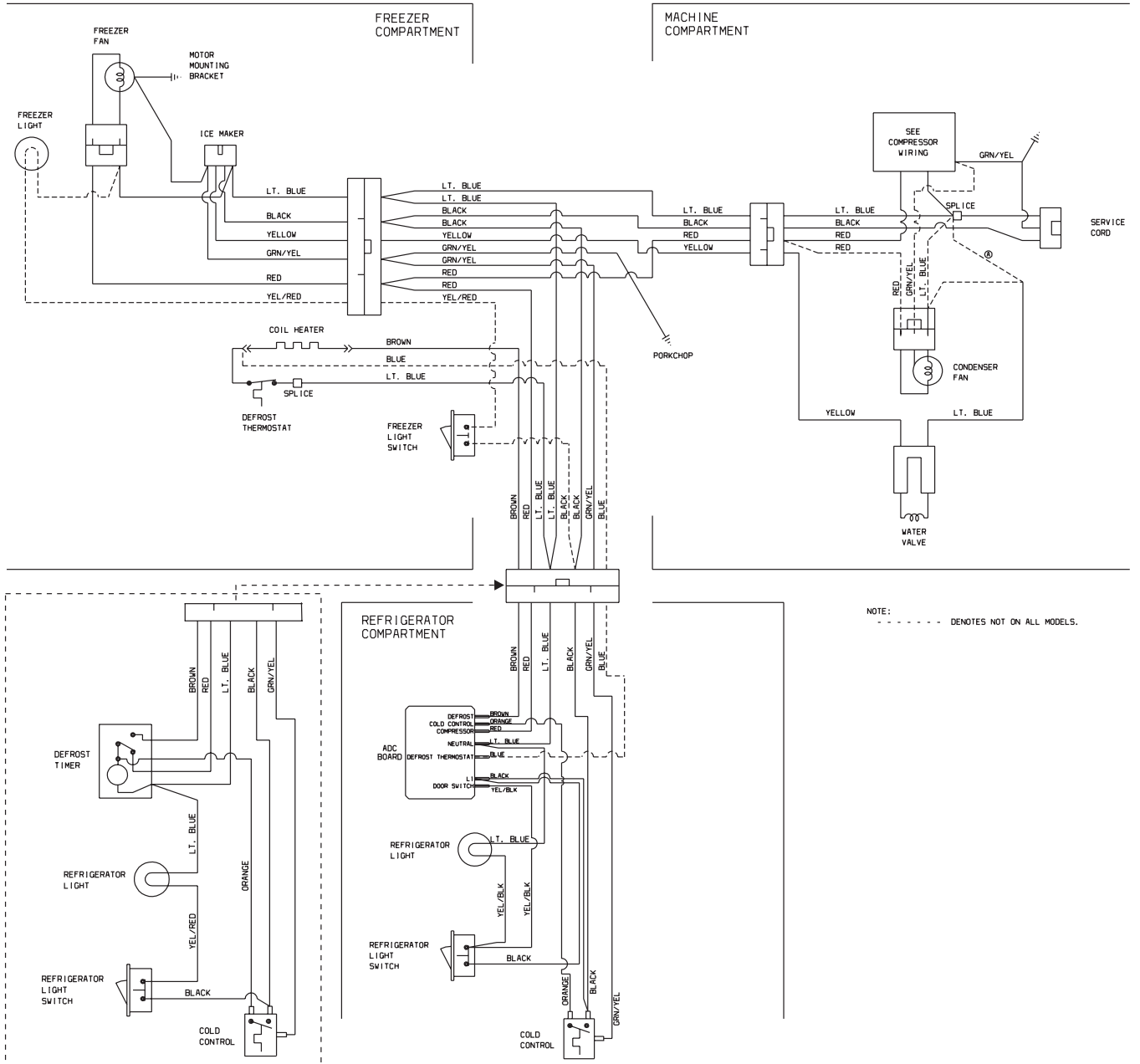

AIR CIRCULATION

AUTOMATIC DEFROST MODELS

Principals Of Automatic Defrost Operation

Automatic defrost refrigerators operate on the principle that moisture or frost transfers or migrates to the coldest surfaces (evaporator) in the freezer compartment. For example, a small amount of water spilled from an ice cube tray in the freezer compartment will freeze immediately. However, this ice in time will evaporate and transfer to the colder surfaces of the freezer evaporator coil.

Air Circulation Patterns

Automatic defrost models have a single evaporator in the freezer compartment, and have forced air cooling in the freezer and refrigerator compartments.

The “fin and tube” aluminum type evaporator is located on the back wall of the freezer compartment. A circulating fan (suction type) pulls air from the air return in the freezer and refrigerator compartments up through the evaporator surfaces from the bottom. The cold air is forced into a fan cover and discharged into the freezer and refrigerator compartments as shown in Figure D1.

Cold air for the refrigerator compartment flows from the evaporator through an air duct located in front of the evaporator cover and into the food compartment through air ducts on the Control Box. Return air from the refrigerator compartment flows through an opening on each side of the control housing, located all the way to the back next to the liner, through a 90° air return duct and back to the evaporator.

Cold air for the freezer compartment flows from the evaporator through an air discharge grill around the fan motor and into the freezer compartment. Return air from the freezer compartment flows through the louvers located on the back wall near the bottom of the freezer compartment, just in front of the evaporator.

The air circulating fan operates only when the compressor is running. During the defrost period, the compressor and circulating fan do not operate. The automatic defrost timer opens the electrical circuit to the fan motor and compressor.

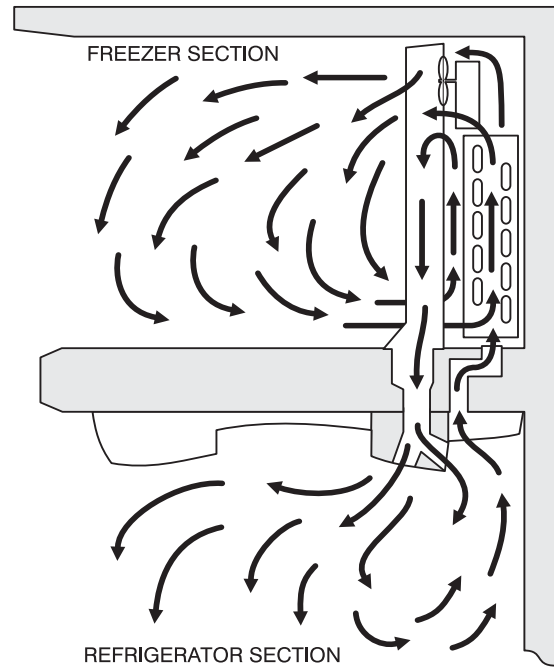

Figure D1

REFRIGERATION SYSTEM

NOTICE: Instructions given here are furnished as a guide. Persons attempting to use these instructions to make repairs to the sealed refrigeration system should have a working knowledge of refrigeration and previous training on sealed system repair, and an EPA certification for servicing refrigeration systems.

IMPORTANT NOTICE

Effective July 1, 1992, the United States clean air act governs the disposal of refrigerants such as R-134a. Therefore, when discharging or purging the sealed system, use an EPA approved refrigerant recovery system as outlined in the final rule on the protection of stratospheric ozone and refrigerant recycling which was published in the Federal Register May 14, 1993.

NOTE: Frigidaire does not permit the use of recovered refrigerant in the servicing of our products for in-warranty and out-of-warranty repairs or for products covered by service contracts. Therefore, only new refrigerant or refrigerant that has been reclaimed back to new specifications by a refrigerant manufacturer is to be used.

DEFINITIONS

Recovery:

To remove refrigerant in any condition from a system and store it in an external container without necessarily testing or processing it in any way.

Recycling:

To clean refrigerant for reuse by oil separation and single or multiple passes through devices, such as replaceable core filter-driers, which reduce moisture, acidity and particulate matter. This term usually applies to procedures implemented at the field job site or at a local service shop.

Reclaim:

To reprocess refrigerant to new product specifications by means which may include distillation. Will require chemical analysis of the refrigerant to determine that appropriate product specifications are met. This term usually implies the use of processes or procedures available only at a reprocessing or manufacturing facility.

SAFETY WARNINGS

Compressor Testing

Whenever testing a compressor, extreme caution should be used to prevent damaging the terminals. A compressor with a damaged terminal or a grounded winding can expel a terminal from its insulated housing when the compressor is energized. If this happens, a mixture of refrigerant and oil will be released that could be ignited by an external heat source (open flame, heater, etc.). Also, if there is air in the system when this happens, a spark at the compressor shell could ignite the refrigerant and oil mixture.

Charging Sealed Systems

Overcharging a refrigeration system with refrigerant can be dangerous. If the overcharge is sufficient to immerse the major parts of the motor and compressor in liquid refrigerant, a situation has been created which, when followed by a sequence of circumstances, can lead to the compressor shell seam separating.

A hydraulic block occurs, preventing the compressor from starting. This condition is known as locked rotor. Electric current continues to flow through the compressor motor windings which become, in effect, electric resistance heaters. The heat produced begins to vaporize the excess refrigerant liquid, causing a rapid increase in system pressure. If the compressor protective devices fail, the pressure within the system may rise to extremes far in excess of the design limits. Under these conditions, the weld seam around the compressor shell can separate with explosive force, spewing oil and refrigerant vapor which could ignite.

To eliminate this exceedingly rare but potential hazard, never add refrigerant to a sealed system. If refrigerant is required, evacuate the existing charge and recharge with the correct measured amount of the refrigerant specified for the system.

SOLDERING

WARNING: WEAR APPROVED SAFETY GLASSES WHEN WORKING WITH OR ON ANY PRESSURIZED SYSTEM OR EQUIPMENT. HAVE AN APPROVED DRY TYPE FIRE EXTINGUISHER HANDY WHEN USING ANY TYPE OF GAS OPERATED TORCH.

1. All joints to be soldered must have proper fit. Clearance between tubes to be soldered should be from .001" to .006". It is not practical to actually measure this; however, you do not want a dry fit or loose fit. Tubing joints should overlap about the distance of their diameter except for restrictor tubes, which should be inserted 1.25"
2. Clean all joint areas with fine steel wool or, preferably, an abrasive cloth, such as grit cloth No. 23 or Scotch-Brite.
3. Apply thin film of liquid flux recommended for silver soldering to surfaces to be joined, and to surfaces immediately adjacent to joint.
4. Align tubing so no stress is on joint. Do not move tubing while solder is solidifying or leaks will result.

CAUTION: During application of heat, use wet cloths to prevent heat from conducting to areas other than soldered joint. Use a sheet of metal as a heat deflector to keep flame away from inflammable materials and painted surfaces.

5. Use a torch of adequate capacity so joint can be quickly heated with a minimum of heat travel to other points. Use a good grade of silver solder.
6. Solder connections. If tubing is properly cleaned and fluxed, solder will flow readily. Use only enough solder to make a good bond.
7. Allow joint to cool, then wash exterior with water to remove flux.

BASIC COMPONENTS

The basic components of a refrigerator are a compressor, condenser, evaporator, heat exchanger (capillary tube and suction line), drier, and perimeter hot tube.

PERIMETER HOT TUBE

To reduce the possibility of condensation forming on the exterior of the cabinet in high humidity areas, a perimeter hot tube (refrigerant tube) has been installed in the unit. The perimeter tube extends up the left side, across the center mullion and down the right side and into the filter drier. When the compressor operates, warm refrigerant flows through the primary condenser, then, into the primary hot tube, warming the cabinet front exterior.

The perimeter hot tube is not replaceable. In the unlikely event of a leak in the hot tube, a kit is available to bypass the hot tube in the sealed system. An electrical heater wire must be installed within the tubing. Refer to the appropriate parts list of the model being serviced for the correct kit part number. See the procedure at the end of this section to install an electric heater.

REFRIGERANT CYCLE

The refrigerant cycle is a continuous cycle that occurs whenever the compressor is in operation. Liquid refrigerant is evaporated in the evaporator by the heat that enters the cabinet through the insulated walls, and by the heat from product load and door openings. The refrigerant vapor is then drawn from the evaporator, through the suction line, to the compressor. Compression raises the pressure and temperature of the vapor in the compressor, and the vapor is then forced through the discharge valve into the discharge line and into the condenser. Air passing over the condenser surface removes heat from the high pressure vapor which then condenses to a liquid. The liquid refrigerant then flows from the condenser to the evaporator, through the small diameter liquid line (capillary tube). Before it enters the evaporator, the liquid refrigerant is sub-cooled in the heat exchanger by the low temperature suction vapor in the suction line.

LOW OR HIGH-SIDE LEAK OR UNDERCHARGE

A loss of refrigerant can result in any of the following:

1. Excessive or continuous compressor operation.
2. Above normal freezer compartment temperature.
3. A partially frosted evaporator (depending on amount of refrigerant loss).
4. Below normal freezer compartment temperature.
5. Low suction pressure (vacuum).
6. Low wattage.

The condenser will be "warm to cool", depending on the amount of refrigerant lost.

When refrigerant is added, the frost pattern will improve, the suction and discharge pressures will rise, the condenser will become hot and the wattage will increase.

In the case of a low side refrigerant leak, resulting in complete loss of refrigerant, the compressor will run, but will not refrigerate. Suction pressure will drop below atmospheric pressure and air and moisture will be drawn into the system, saturating the filter drier.

If a slight undercharge of refrigerant is indicated, and no leak can be found after a thorough leak test, the charge can be corrected without changing the compressor.

If there is reason to believe the system has operated for a considerable length of time with no refrigerant, and the leak occurred in the evaporator, excessive amounts of

moisture may have entered the system. In such cases, the compressor may need to be replaced to prevent repetitive service.

If a high-side leak is located and some refrigerant remains in the system, it is not necessary to change the compressor.

TESTING FOR REFRIGERANT LEAKS

If the system is diagnosed as short of refrigerant and the system has not been recently opened, there is probably a leak in the system. Adding refrigerant without first locating and repairing the leak, or replacing the component, will not permanently correct the difficulty. **The leak must be found.** Sufficient refrigerant may have escaped to make it impossible to leak test effectively. In such cases, add a 1/4" line piercing valve to the compressor process tube. Add sufficient refrigerant vapor to increase the pressure to 40 to 50 lb. per sq. in. Check the low side for leaks. Run the compressor 2 or 3 minutes and check the high side for leaks. Recover refrigerant using an EPA approved recovery system.

NOTE: The line piercing valve (clamp-on type) should be used for test purposes only. It must be removed from system after it has served its purpose.

CHECKING FOR INTERNAL (HOT TUBE) LEAKS

Before checking for internal leaks, check all accessible system components and joints for leaks.

If an internal hot tube leak is suspected, it must be confirmed. Use the following procedure:

1. Recover refrigerant by using EPA approved recovery system.
2. After *system refrigerant* is completely recovered, disconnect drier from hot tube. Pinch off and solder end of hot tube closed.
3. Cut line from condenser to hot tube and solder a 1/4" charging hose fitting to open end of hot tube or put compressor fitting on tube.
4. Connect pressure gauge and access valve to hot tube, and pressurize to 250 psig using dry nitrogen or carbon dioxide.

WARNING: NEVER PRESSURIZE WITH OXYGEN. NEVER OPEN A HIGH PRESSURE TANK UNLESS IT IS EQUIPPED WITH A PRESSURE REGULATOR. NEVER PUT HIGH PRESSURE ON DOME OF COMPRESSOR—IT COULD EXPLODE. MAKE SURE GAUGE FITTINGS ARE IN GOOD CONDITION AND DO NOT LEAK.

5. Leave pressure on hot tube for 24 hours. Any drop in pressure is indication of leak.

If dry nitrogen or carbon dioxide is not available, follow steps 1 through 3 above, then steps 4 and 5 below:

4. Connect gauges to charging hose fittings. Pull vacuum on hot tube.
5. Leave vacuum on each side of system for 24 hours. Any loss of vacuum indicates leak.

COMPRESSOR REPLACEMENT

CAUTION: NEVER install a new compressor without first checking for possible system contamination.

To check for contamination, obtain oil sample from old compressor.

- If the oil has burned odor, but no color change or residue — follow instructions in section "*Installing A New Compressor*" on page 38".
- If oil has a burned sugar odor and shows contamination (dark color) — follow instructions in next section, *To Flush The System*. Remove as much of contamination as possible from system before installing new compressor and filter-drier.

To Flush The System

NOTE: It is recommended that system be flushed with dry nitrogen. However, if refrigerant is used to flush system, you must look at the serial plate to see what type of refrigerant is used in the system. This is the only refrigerant that can be used to flush the system and it must be recovered.

CAUTION: Use extreme care when using dry nitrogen to flush systems. Pressure in nitrogen cylinder could be as high as 2000 psi. Nitrogen cylinder must be equipped with approved pressure regulator and pressure relief valve. Ensure that your hoses have adequate ratings for pressure involved, and that all of your equipment is in good condition.

CAUTION: The end of flushing hose off tank regulator must be equipped with a hand shut-off valve (Robinair No. 40380). Close hand shut-off valve and adjust nitrogen regulator to correct pressure before proceeding with flushing procedure.

To Use Dry Nitrogen To Flush The System:

1. Remove compressor and filter-drier. Connect process coupling to outlet tube of condenser.
2. Fasten cloth over other end of coil to prevent old oil from spraying over room.

3. Connect hand shut-off valve on flushing hose to process coupling.
4. Slowly open hand shut-off valve and allow nitrogen to flow through condenser until discharge is clear.

CAUTION: DO NOT exceed 300 PSIG.

5. Disconnect cap tube from evaporator. Flush evaporator in same manner as condenser.

CAUTION: DO NOT exceed 150 PSIG.

6. Flush cap tube. This is only possible if you have proper service valve adaptor.

CAUTION: DO NOT exceed 300 PSIG.

7. Reassemble system.

To Use Refrigerant To Flush The System:

CAUTION: Refrigerant used for flushing must be recovered into a recovery bag. Meter amount of refrigerant used for flushing with your charging cylinder. DO NOT OVERFILL THE BAG.

1. Disconnect the suction and discharge lines from the compressor and remove the filter-drier. Connect process coupling to outlet and inlet tube of condenser.
2. Connect hose to outlet process coupling and charging cylinder. Connect another hose to inlet coupling and recovery bag.
3. Open charging cylinder and allow refrigerant to flow through condenser until discharge into bag is clear.

NOTE: To flush evaporator and heat exchanger you must remove evaporator from inside product to disconnect cap tube.

4. Disconnect capillary tube from evaporator. Flush evaporator in same manner as condenser.
5. Flush cap tube. This is only possible if you have proper service valve adaptor.
6. Reassemble system.

Installing a New Compressor

NOTE: Entirely new compressors have been developed for use with R-134a and Ester oil refrigeration systems. Both compressor and electric motor have been modified. Old compressors intended for R-12 refrigerant must not be used for new systems charged with R-134a.

Replacement of compressor and installation of filter-drier must be done in continuous sequence so system is exposed to atmosphere no longer than necessary.

All replacement compressors are shipped with rubber plugs in the suction, discharge, and process tubes and contain the

correct oil charge and a holding charge of inert gas. Compressors have a low-side process tube attached to the compressor shell. A high-side process tube is attached to the filter-drier.

WARNING: DO NOT OPERATE RECIPROCATING COMPRESSOR WHEN CHARGING LIQUID REFRIGERANT INTO SYSTEM THROUGH ITS PROCESS TUBE.

Replacement compressors for refrigerators and food freezers may have an oil cooler even if the original compressor did not. If the product is not equipped for an oil cooler, leave the plastic caps in place and install the compressor, connecting only to the suction and discharge lines of the new compressor.

Before installing the replacement compressor, remove the discharge plug and check for the pop sound of the inert gas leaving the compressor.

CAUTION: DO NOT use compressor if you do not hear this sound.

If the compressor checks OK, reinstall the plug. Do not remove any of the plugs again until the compressor is in position and you are ready to braze the lines.

CAUTION: On R-134a systems, compressor must NOT be left open to atmosphere for more than 10 minutes to prevent moisture contamination of oil.

A new compressor which is cold (e.g. after having been kept in a cold service van) should be left to warm to the surrounding temperature before the plugs on the compressor connections are removed. This will help prevent condensation from forming in the oil and the compressor. Also, avoid opening the system when any of the components or lines are cold.

NOTE: Release holding charge (release slowly to avoid oil discharge) on new compressor to ensure that there is no leak in seam or tubing. Then, reinstall rubber plug.

1. Disconnect electrical supply to refrigerator.
2. Remove compressor access panel.
3. Remove rail and condenser fan shroud screws.
4. Remove fan motor harness clamp located below heat exchanger wiring harness cover.
5. Disconnect condenser fan motor multiconnector.
6. Pull compressor assembly straight out (See Figure E1).
7. Recover refrigerant by using EPA approved recovery system.
8. Remove leads from compressor motor terminals.
9. Remove mounting clips and washers.
10. After refrigerant is completely recovered, cut suction and discharge lines as close to compressor as possible. Leave only enough tubing to pinch off and seal defective compressor. Plug or tape any open system tubing to avoid entrance of moisture and air into system. Remove inoperable compressor and transfer mounting parts to new compressor.

11. Install new compressor in exact same manner as original compressor.
12. Reform both suction and discharge lines to align with new compressor. If they are too short, use additional lengths of tubing. Joints should overlap 0.5" to provide sufficient area for good solder joint. Clean and mark area where tubing should be cut. Cut tubing with tubing cutter. Work as quickly as possible to avoid letting moisture and air into system.

NOTE: If low-side process tube is too short, silver solder four inch piece of tubing onto process tube at this time.

13. Solder all connections according to soldering procedure outlined above.
14. Remove original filter-drier.

CAUTION: DO NOT unbraze old filter-drier from system. This will vaporize and drive moisture from desiccant back into system. The old filter-drier should be cut out of system.

15. Install new filter-drier at condenser outlet.
16. Evacuate and charge system using recommended procedure described under *Evacuating and Recharging* on pages 44-45.
17. Reconnect compressor terminal leads in accordance with refrigerator wiring diagram.
18. Reassemble unit.

Figure E1

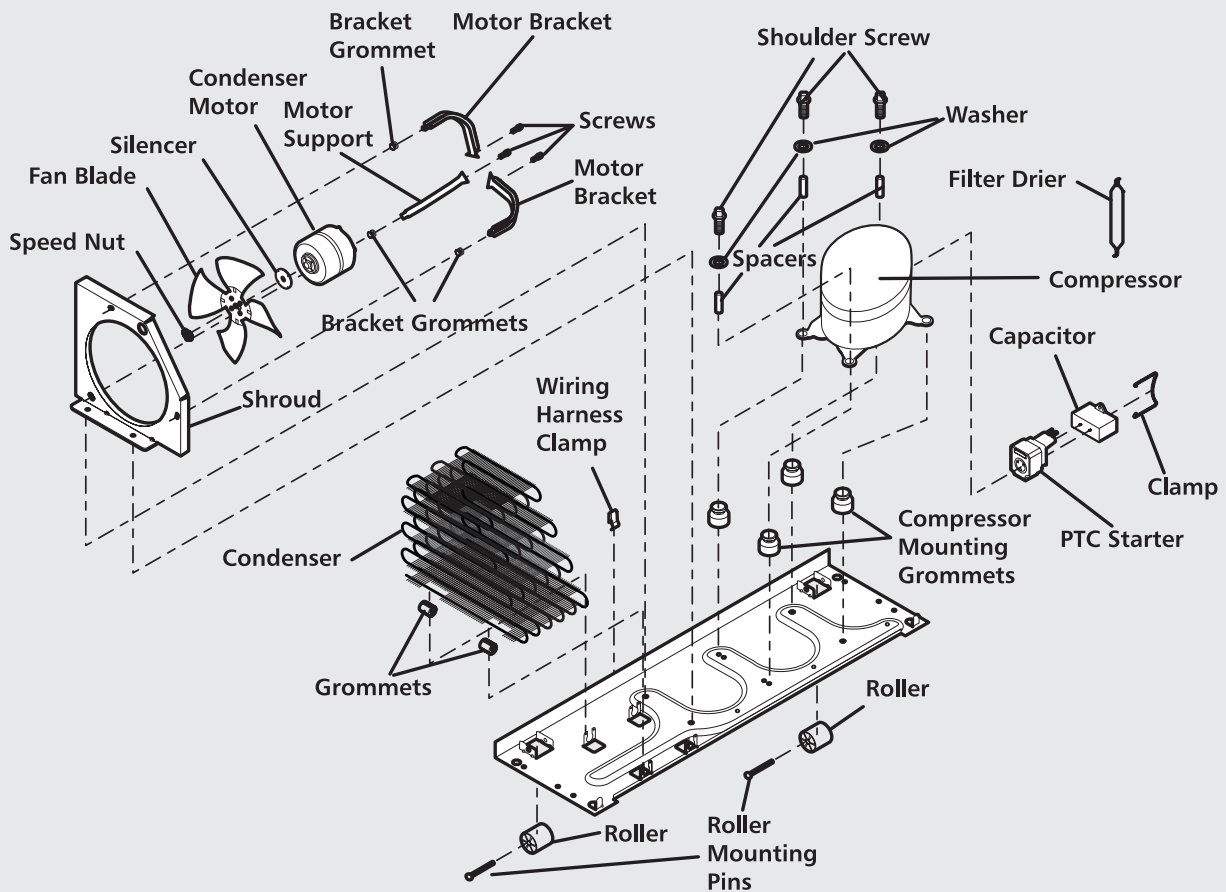

EVAPORATOR REPLACEMENT

CAUTION: Remove any component part from the interior of the cabinet before attempting to solder. The excessive heat from soldering will warp the plastic liner.

The evaporator is located in the upper section of the freezer and is secured to the drain pan by top and bottom brackets. Styrofoam blocks are located on each side, directly across from each other, to ensure proper air flow through the evaporator.

The heat exchanger on this style of refrigerator is in the insulation between the back of the food liner and the back of the cabinet. Because of this, you will not be able to remove the heat exchanger with the evaporator. You will make your line welds inside the freezer compartment. The kit contains a heat shield to protect the liner from damage when making your line welds.

This kit contains:

1 Evaporator	1 Heat shield
1 Drier-Filter	1 Instruction Sheet

1. Disconnect electrical supply to refrigerator.
2. Remove all freezer section shelves and baskets.
3. Recover refrigerant using EPA approved recovery system.
4. Remove evaporator coil cover.
5. Cut suction line between weld and evaporator. Using file, score and break cap tube just above weld. (See Figure 1.)

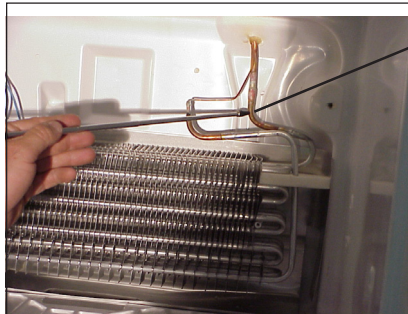

To replace evaporator, cut suction line at this point.

FIGURE 1

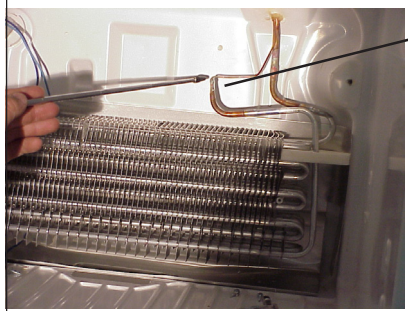

Cut cap tube at this point.

6. Disconnect limiter and defrost heater.
7. Clean end of suction line and cap tube. Straighten and slightly bend toward front of cabinet.
8. Cut small "X" in heat shield and slide cap tube and suction line through hole. Pack heat shield in top corner of liner. (See Figure 2.) You may want to use small pair of vise-grips on suction line to help hold heat shield in place.

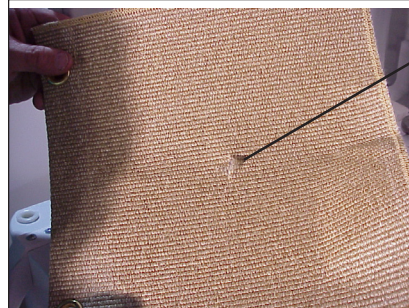

Cut small hole in middle of the shield.

FIGURE 2

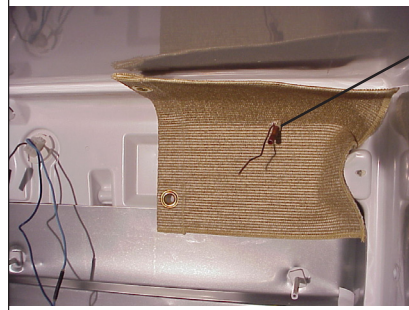

Place shield over heat exchanger and push into top corner of liner.

9. Install defrost heater in new evaporator and set inside freezer. Do not push all the way in place. Sit evaporator 2 to 3 inches out from liner. This will allow additional room for welding. (See Figure 3.)

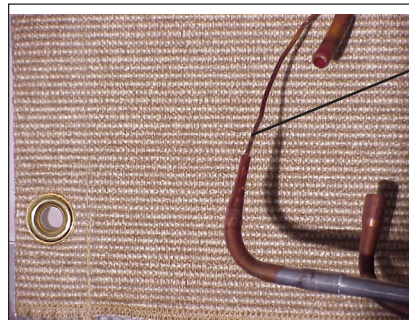

Make your weld on cap tube first.

FIGURE 3

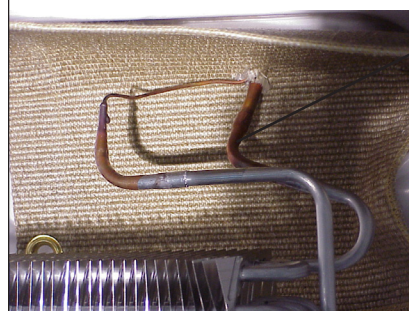

Now make your weld on suction line.

10. Place cap tube in new evaporator and weld in place. Put suction line in new evaporator and weld in place. (See Figure 3.)
11. Using sharp knife, cut along a seam on heat shield, from hole for lines to right edge of shield. Slide shield off suction line assembly.
12. Push evaporator back in place and connect heater. Mount limiter on evaporator.
13. Replace Drier-Filter. Pump down and recharge system.
14. Allow product to run and make sure refrigerant is circulating.
15. Reinstall evaporator cover and compartment cover, if so equipped.

HEAT EXCHANGER KIT REPLACEMENT

The original heat exchanger (Suction Line & Cap Tube Assembly) in this refrigerator is enclosed in the insulation between the liner and the cabinet at the back. Because of this, you can not remove the original part. It will be necessary to run a new heat exchanger down the back of the refrigerator and bypass the internal heat exchanger.

This kit contains:

1 Heat Exchanger	12 Screws
1 Drier-Filter	1 Cover, Upper
1 Armor Flex	1 Cover, Lower
2 Tape	1 Package Permagum
1 Instruction Sheet	

To replace the Heat Exchanger:

1. Recover refrigerant from sealed system.
2. Remove evaporator cover and disconnect defrost heater and limit thermostat wires.
3. Cut heat exchanger off flush with liner. (See Figure 1.)

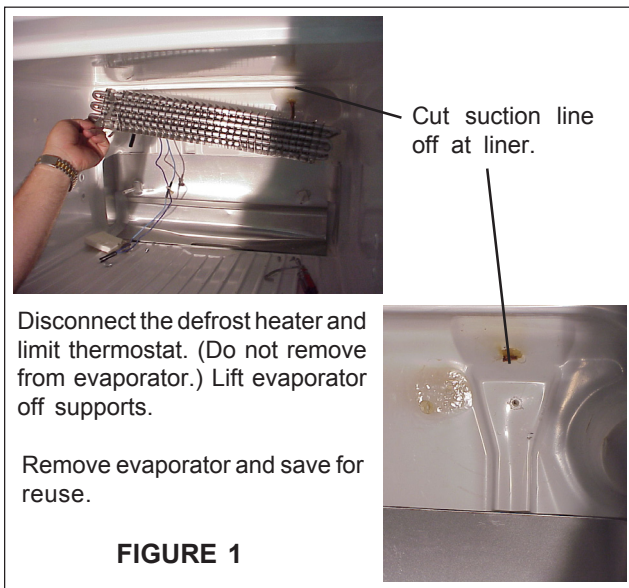

4. Recover evaporator. (You do not need to remove defrost heater.)
5. Using 1/4 drill bit, drill hole through the cabinet from inside at location shown in Figure 2.
6. Using 1/2" drill bit, open hole drilled in Step 5 to 1/2" from back of product. See Figure 2.

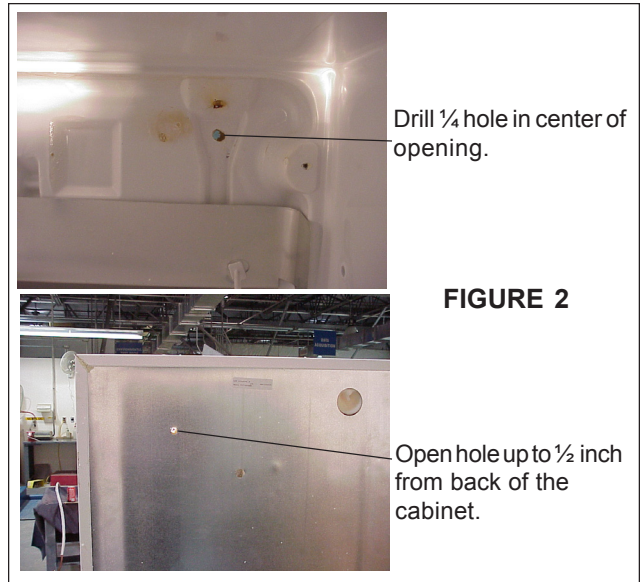

7. Remove stubs of old heat exchanger from evaporator and install new heat exchanger into evaporator.
8. Push heat exchanger through hole in cabinet (see Figure 3) and set evaporator in place.
9. Excess cap tube can be folded from bottom so it is alongside suction line and will be inside Armor Flex. Slide Armor Flex over line covering excess cap tube until cover is against hole at back of cabinet. (See Figure 3.)

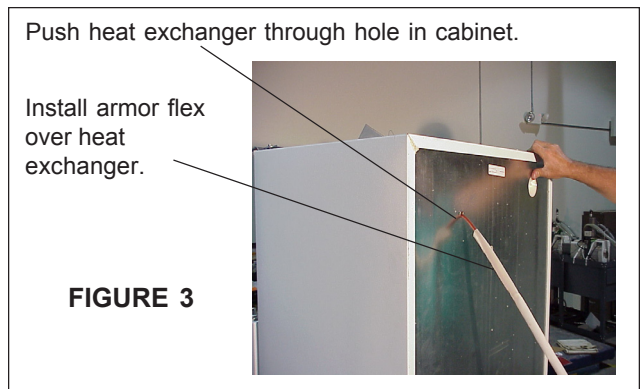

10. Seal hole on inside and outside using Permagum in the kit.
11. The two piece cover can now be installed to cover heat exchanger. One cover is closed on one end. This is top section and will be installed last. Using section that is open on both ends, set it even with bottom of compressor compartment opening. Using screws provided with kit, screw cover to back of cabinet. Screws will cut their own holes so no predrilling is necessary. (See Figure 4.)

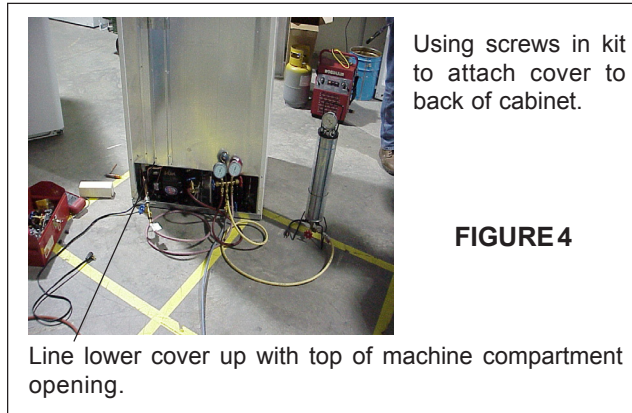

12. Upper section closed end should be installed at top against seam between painted cabinet and back galvanized part of cabinet. Bottom of cover will overlap lower section. Attach upper cover using remainder of screws.
13. Replace Drier-Filter. Pump down and recharge system.
14. Allow product to run and make sure refrigerant is circulating. Reinstall evaporator cover and compressor compartment cover.

PERIMETER HOT TUBE REPAIR KIT

Effective July 1, 1992, Section 608 of the **Clean Air Act** prohibits Individuals from knowingly venting ozone depleting compounds used as refrigerants into the atmosphere while maintaining, servicing, repairing, or disposing of refrigerant equipment.

A hot tube repair kit is used to bypass a leaking Perimeter Hot Tube (Yoder-Loop). The Perimeter Hot Tube must be cut out of the sealed refrigeration system and a low wattage heater wire installed inside the tube. This heater will prevent condensation from forming on the exterior front edge of the cabinet.

This kit contains:			
1	Copper Bypass Tube	1	Plastic Sleeve
1	Drier-Filter	1	Heater Wire
3	Clamps	1	Harness Adapter
3	Screws	2	Wire Connectors

BYPASSING PERIMETER HOT TUBE - STEP 1

1. Disconnect service cord from power supply.
2. Recover refrigerant from system.
3. Remove filter-dryer.
4. Using tubing cutter, cut and de-burr tubing from perimeter hot tube at points shown in figure below.

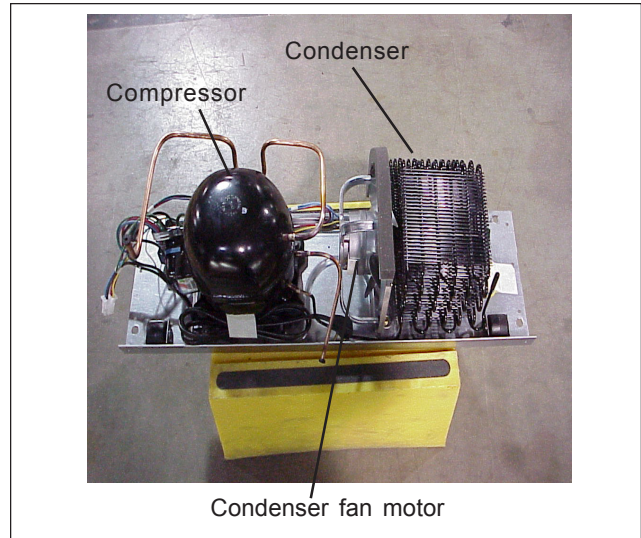

5. Install copper bypass tube and replacement filter-dryer as shown in figure below. Use 45% silver solder for all connections.

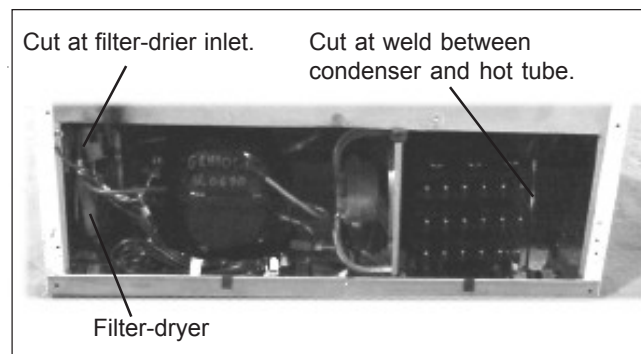

6. Drill or pierce three holes in cabinet to hold clamps. Secure by-pass tube just below cabinet edge with three clamps and screws provided.

NOTE: When clamped in place, the by-pass tube should NOT touch any plastic lines, like water lines for ice makers and/or filters, as well as drain lines.

7. Evacuate and recharge refrigeration system. Refer to serial plate for correct charge.

INSTALLING THE HEATER WIRE - STEP 2

1. Attach Vacuum Pump and Gauge Set to one end of Perimeter Hot Tube with an Adapter and Plastic Sleeve. See illustration on next page.
2. Cutoff waxed end of Fiberglass braid that is extended past end of heater wire and make knot in end just a little smaller than inside diameter of hot tube.
3. Insert knot on end of braid into open end of Perimeter Hot Tube.
4. With braid inserted, start Vacuum Pump and place your thumb over end of tube. When good vacuum is obtained, release your thumb and begin to feed braid into Hot tube. Continue this process until string reaches Plastic Sleeve.

NOTE: Take the time to remove all the bends from the heater (caused from being rolled up) by pulling the heater and braid through a shop rag with a small amount of silicone on the rag and laying it in a roll at the open end of the Hot Tube it will make heater installation go faster. Using of a good two stage, 5 CFM Vacuum Pump will also make heater installation go faster.

5. Disconnect Plastic Sleeve.
6. Pull braid out while pushing equal amount of braided heater into tube at other end until heater wire inside braid appears.

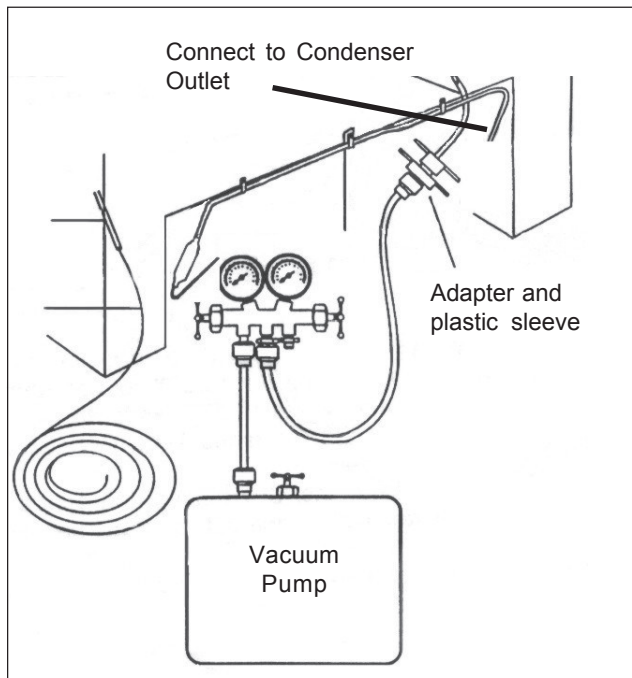

INSTALLING THE HEATER WIRE - STEP 3

1. Remove wires (with terminals) from compressor starter/overload. On some models you will need to depress locking tabs located in relay housing (See Drawing below.)

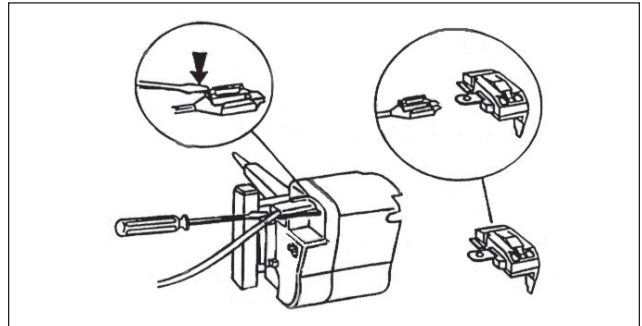

2. Install harness adapter into refrigerator circuit as shown below.

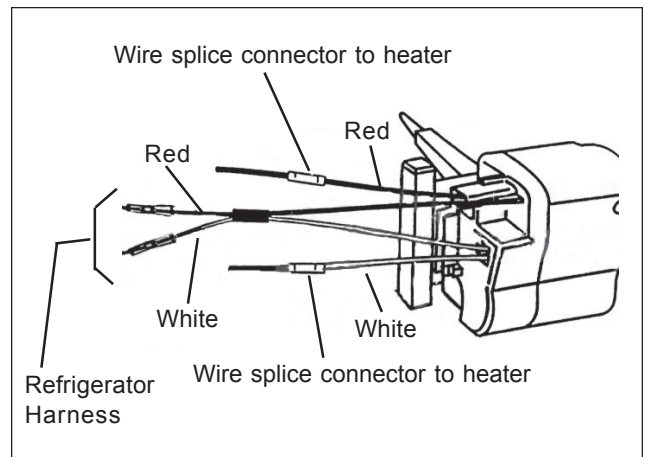

3. Cut off braid at start of heater. Strip insulation back about 5/16 inch. Be careful not to damage heater resistance wire. Splice heater wire ends to loose leads of adapter harness with furnished wire connectors.
4. Dress wires away from Condenser Fan Blade and any sharp edges.
5. Secure wires with electrical tape as necessary.
6. Reinstall Back Panel for proper air flow over condenser and compressor.

CONDENSER REPLACEMENT

1. Disconnect electrical supply to refrigerator.
2. Remove compressor access panel.
3. Remove rail and condenser fan shroud screws.
4. Remove fan motor harness clamp located below heat exchanger wiring harness cover.
5. Disconnect condenser fan motor multiconnector.
6. Pull compressor assembly straight out.
7. Recover refrigerant, using an EPA approved recovery system.

8. Remove wiring from compressor.
9. After refrigerant is completely recovered, disconnect suction and discharge lines from compressor.
10. Remove condenser mounting clips that secure drain pan and remove condenser.
11. Install replacement condenser.
12. Remove original filter-drier.

CAUTION: DO NOT unbrazed the old filter-drier from the system. This will vaporize and drive moisture from the desiccant back into the system. The old filter-drier should be cut out of the system.

13. Install new filter-drier at condenser outlet.
14. Evacuate and charge the system using recommended procedure described under *Evacuating and Recharging*.
15. Reassemble unit.

SUCTION LINE AND CAPILLARY TUBE REPLACEMENT

Follow the same procedure used for evaporator replacement.

FILTER-DRIER INSTALLATION

Any time the sealed system is opened and the refrigerant charge is removed, the liquid line filter-drier must be replaced and the system thoroughly evacuated before recharging.

CAUTION: DO NOT unbrazed the old filter-drier from the system. This will vaporize and drive moisture from the desiccant back into the system. The old filter-drier should be cut out of the system.

CAUTION: Use only a 15 gram XH9 liquid line filter-drier (part number 5303305677) when servicing refrigerator and freezer systems. This filter-drier is compatible with either R-12 or R-134a refrigerant.

1. Disconnect electrical supply to refrigerator.
2. Recover refrigerant by using EPA approved recovery system.
3. Using three cornered file, score groove around capillary tube as close to old filter-drier as possible. Break capillary tube along score mark from filter-drier.
4. Cut condenser outlet tube at filter-drier. Discard filter-drier.
5. Thoroughly clean condenser outlet tube and capillary tube.
6. Place inlet connection of filter-drier over condenser tube approximately 1/4" and solder.
7. Insert capillary tube input end into filter-drier outlet. Do not allow tube to bottom against screen. Solder

carefully so that solder does not plug capillary tube.

8. Install process tube adaptor to filter-drier.
9. Evacuate and charge system using recommended procedure described under *Evacuating and Recharging*.
10. Reassemble unit.

EVACUATING AND RECHARGING

CAUTION: Check the serial plate for the correct refrigerant type. It is extremely important to verify the type of refrigerant in the system before starting any sealed system repairs.

CAUTION: With the possible exception of the vacuum pump, all service equipment that comes in contact with R-134a during evacuation and recharging must be dedicated. Accordingly, R-134a will require a dedicated charging cylinder, manifold gauge set, process tube adaptors, and hoses. Any residual mineral oil on other tools (tubing cutter, etc.) must be thoroughly cleaned off before using on R-134a/Ester oil systems. It will be necessary to check with the manufacturer of your vacuum pump for refrigerant and oil compatibility issues.

CAUTION: If you use a vacuum pump with mineral oil to evacuate an R-134a system, it is ABSOLUTELY ESSENTIAL to have a shut-off valve between the pump and your manifold gauge set as shown in Figure E2. The hand valve must be closed during all times when the vacuum pump is not operating. This will prevent the migration of mineral oil vapor into the R134a/Ester oil system. If the vacuum pump should stop during evacuation for any reason, the hand pump shut-off valve must be closed immediately.

CAUTION: Ensure that your refrigeration hoses are specifically for use with R-134a refrigerant. Research has shown that compounds in standard refrigeration hoses may enter sealed systems and ultimately restrict the cap tube in an R-134a system.

Equipment Needed:

- Heated Dial-A-Charge charging cylinder
- Standard 3-port manifold gauge set:
 - 4 charging hoses
 - Tee fitting with valve core stem removed (Robinair No. 40396)
 - Hand shut-off valve (Robinair No.40380)
- Two stage vacuum pump

- Process tube adapter kit (Robinair No. 12458)
- Tubing cutter
- Pinch-off tool capable of making leak proof seal
- Complete brazing torch set
- Small 3-corner file
- Grit cloth or Scotch-Brite
- 45% silver solder and flux

Installing Evacuation and Recharging Equipment

1. Disconnect refrigerator from electrical supply.
2. If compressor was replaced, install correct size process tube adaptor on process tube. If compressor was not replaced, cut process tube with tubing cutter, leaving as much tube as possible, and install correct size process tube adaptor.
3. Install correct size process tube on high-side process tube.
4. Attach refrigeration service gauge manifold to system in following order:
 - Low-side (compound gauge) hose to suction side process tube adaptor.
 - High-side (pressure gauge) hose to high-side process tube adaptor.
 - Center port manifold hose before hand shut-off valve to charging cylinder.
 - Center port manifold hose after hand shut-off valve to vacuum pump.
4. Operate the vacuum pump for minimum of 30 minutes to attain minimum of 29.9" (500 micron) vacuum.
5. Close hand shut-off valve to vacuum pump. Watch compound gauge for several minutes. If reading rises, there is leak in system, go to step 6. If no leak is indicated, stop vacuum pump. System is now ready for charging.
6. If leak is indicated, stop vacuum pump and introduce small charge of refrigerant into system by cracking valve on bottom of charging cylinder until system is pressurized to 40 or 50 lbs, psig.
7. Leak test low-side. Close compound gauge. Run compressor for few minutes and leak test high-side. When leak is found, recapture refrigerant using EPA approved recovery system, repair and go back to step 1.

Evacuating System

WARNING: R134A SYSTEMS ARE PARTICULARLY SUSCEPTIBLE TO MOISTURE CONTAMINATION WHICH CAN ONLY BE PREVENTED BY EVACUATING THE SYSTEM FOR A MINIMUM OF 30 MINUTES TO ATTAIN A MINIMUM 29.9 INCH (500 MICRON OR LOWER) VACUUM.

To achieve the required levels of evacuation, a properly maintained two-stage vacuum pump in good condition is required. It is absolutely essential to maintain your vacuum pump according to the manufacturer's instructions including required oil changes at the recommended intervals. Vacuum pump oil should always be changed after evacuating a contaminated system.

Vacuum pump performance should be checked periodically with a micron gauge.

1. Make certain that charging cylinder valve, hand shut-off valve, and manifold gauge valves are closed.
2. Start vacuum pump.
3. Open hand shut-off valve and slowly open both manifold valves, turning counterclockwise, for two full rotations.

CAUTION: If high vacuum equipment is used, just crack both manifold valves for a few minutes, then open slowly for the two full turns, counterclockwise. This will prevent the compressor oil from foaming and being drawn into the vacuum pump.

Charging The System

CAUTION: Check the serial plate for the correct refrigerant type. It is extremely important to verify the type of refrigerant in the system before starting any sealed system repairs.

CAUTION: After charging the system with liquid, be certain to wait at least 5 minutes before starting the compressor to give the refrigerant a chance to disperse throughout the system. Otherwise, the compressor could be damaged by attempting to pump excessive quantities of liquid.

Preparing The Charging Cylinder:

1. Make certain that hand shut-off valve to vacuum pump is closed.
2. Close high-side manifold gauge valve.
3. Set charging cylinder scale to pressure indicated on cylinder pressure gauge.
4. Observe refrigerant level in sight glass. Subtract amount to be charged into system and note shut off point.
5. Open charging cylinder valve slowly and allow proper charge to enter system.
6. As soon as refrigerant in sight glass has gone down to predetermined level, close charging cylinder valve.

WARNING: DISCONNECT THE CHARGING CYLINDER HEATER AT THIS TIME TO PREVENT THE CYLINDER PRESSURE FROM EXCEEDING ITS MAXIMUM LIMITS.

7. Allow system to sit for five minutes.
8. Turn on refrigerator compressor. Run compressor for few minutes and monitor system pressures.
9. When satisfied that unit is operating correctly, clamp high-side process tube with pinchoff tool while unit is still running.
10. Slowly open high-side manifold gauge valve to allow compressor to remove any refrigerant trapped in high-side hose and process fitting.
11. Close both manifold gauge valves. If high-side gauge reading rises, pinch-off must be corrected before proceeding.
12. Remove high-side process tube adaptor and solder process tube closed.
13. Clamp low-side process tube with pinchoff tool while unit is running. Remove low-side process tube adaptor and solder process tube closed.
14. Check process tubes for refrigerant leaks.

FINAL LEAK TEST

1. With refrigerator turned OFF, leak test all low-side system components.
2. Turn unit ON and run until condenser is warm. Leak test high-side system components.

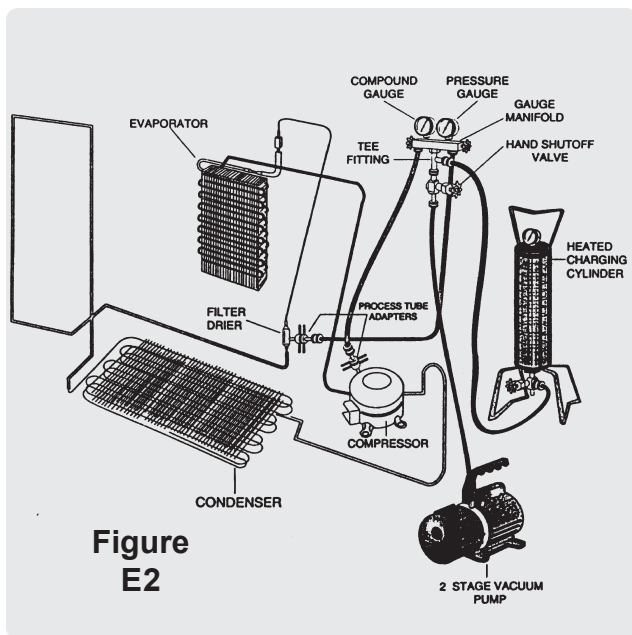

R-134a SERVICE INFORMATION

NOTICE: Instructions given here are furnished as a guide. Persons attempting to use these instructions to make repairs to the sealed refrigeration system should have a working knowledge of refrigeration and previous training on sealed system repair.

VERIFY REFRIGERANT TYPE IN THE SYSTEM

CAUTION: R-134a and R-12 are completely incompatible. Before starting any sealed system repair, it is extremely important to check serial plate of product to verify the type of refrigerant in the system.

Dedicated Equipment

R-134a must not be mixed with other types of refrigerants. R-134a must be recovered in dedicated and properly identified recovery bags and tanks.

Check with the manufacturer of your recovery equipment to determine R-134a compatibility. Some recovery equipment manufacturers have changeover instructions for switching between refrigerant types. Protect yourself and your equipment by following all manufacturer guidelines.

Also, ensure that your refrigeration hoses are specifically for use with R-134a refrigerant. Research has shown that compounds in standard refrigeration hoses may enter sealed systems and ultimately restrict the cap tube in an R-134a system.

R-134a REFRIGERATION SYSTEMS

R-134 sealed refrigeration systems consist of the same basic components utilized in the R-12 systems.

There is a 10% to 15% discharge pressure increase using R-134a, with a 5% to 10% decrease in suction pressure when compared to the same product with an R-12 system operating at 90°F (32°C) ambient temperature. Lower suction pressures result from the lower density of R-134a refrigerant which effects refrigerant flow rate. R-134a systems commonly operate in a 1"-2" vacuum on the suction side.

Products using R-134a refrigerant will generally have a longer capillary tube to maintain a similar flow rate. Some models have a larger condenser to reduce the discharge pressures and lower start-up sound transmission.

MISCIBILITY OF R-134a AND ESTER OIL

A special synthetic oil known as Ester oil is used as a lubricant in refrigeration systems operating on R-134a. Ester oils are produced from alcohols and fatty acids

and are available in several different variants. Ester oils have a pleasant aroma reminiscent of fruit.

Ester oils generally include various types of additives for improving certain properties such as viscosity, temperature sensitivity, etc. These additives are often aggressive, so skin contact with Ester oils should be avoided.

One of the most important demands made on a refrigerant system is that the oil mix with the refrigerant. Since mineral oil and ordinary synthetic oil DO NOT mix with R-134a, Ester oil is used for lubrication. Ester oil dissolves in R-134a.

Ester oil is broken down by chlorine and cannot be used with R-12 (R-12 contains chlorine) or any other compound containing chlorine. Therefore, R-134a refrigeration systems have virtually no tolerance for chlorine molecules from CFC refrigerants (R-134a is an HFC refrigerant and contains no chlorine).

CAUTION: During R-134a service, it is extremely important to avoid using equipment that may contain residual amounts of mineral oil, CFC's or HCFC's which could enter and contaminate the sealed system.

For example, hoses that were used in a refrigeration system operating on R-12 may contain small quantities of mineral oil which can block the capillary tube in a system operating on R-134a. As little as one milligram may be sufficient to cause a blockage. In addition, sealed system components that have been used with CFC systems must not be used with R-134a systems. These components may contain residual amounts of refrigerant and oil which could damage an R-134a system.

At the earliest stage of developing R-134a, tests were carried out on a different type of synthetic oil known as Poly-Alkaline Glycol (PAG). This oil is also used in certain air conditioning systems for cars. PAG and Ester oil DO NOT mix with one another. Service equipment used for R-134a / Ester oil must not come into contact with PAG.

WATER IN THE REFRIGERATION SYSTEM

Even in very small quantities, water in any refrigeration system can cause the following problems:

- Ice plugs in capillary tubes.
- Copper plating in compressor.
- Reactions with organic materials in systems.
- Corrosion of metals.

R-134a and Ester oil will aggravate the problem of water in the refrigeration system. Ester oil may react with water vapor and is hydroscopic (it will absorb water if it comes in contact with humid air). Water is also more soluble in R-134a than R-12.

To minimize the water content whenever service work is performed, the refrigeration system should always be thoroughly evacuated through process tube adaptors on both the high and low sides of the system. Evacuation must be for a minimum of 30 minutes to at least a 29.9 inch (500 micron) vacuum.

VACUUM CHART		
Vacuum Inches Hg.	Microns	Boiling Point of Water °F
28.940	25000	77.9
29.530	10000	52.0
29.832	4600	32.0
29.882	1000	1.0
29.901	500	-11.2
29.915	150	-32.8
29.917	100	-38.2
29.919	50	-49.0

To achieve the required 29.9 inch (500 micron) vacuum, a properly maintained two-stage vacuum pump in good condition is required. A two-stage pump can reach a deeper vacuum than a single-stage because the exhaust from the first pumping stage is discharged into the second pumping stage. This means the second stage begins pumping at a lower pressure so a lower ultimate vacuum can be achieved (See 2-Stage Vacuum Pump, Figure E3).

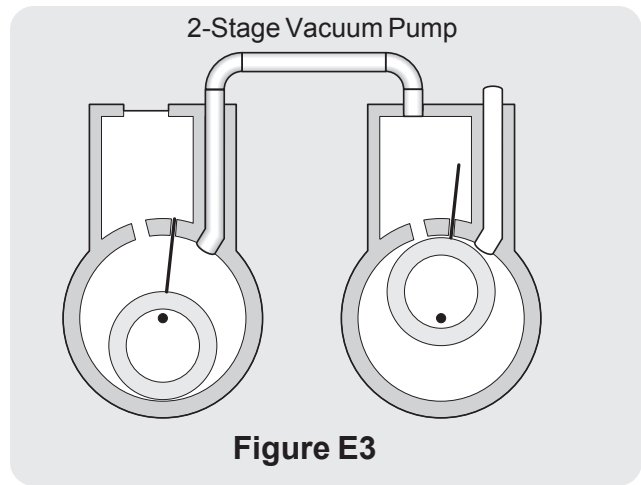

VACUUM PUMP MAINTENANCE

It is absolutely essential to maintain your vacuum pump according to the manufacturer's instructions including required oil changes at the recommended intervals. Vacuum pump oil should always be changed after evacuating a contaminated system. Vacuum pump performance should be checked periodically with a micron gauge.

Vacuum pump suppliers may or may not recommend changing the vacuum pump oil to the same type that's in the system being evacuated. Some manufacturers may recommend a vacuum pump that's dedicated to R-134a systems.

Robinair has stated that their current and discontinued vacuum pump models, using mineral oil currently specified for use in their vacuum pumps, can be used to evacuate R-134a/Ester oil systems. Robinair also states that it is acceptable to alternate between evacuating R-12/mineral oil and R-134a/Ester oil systems without adversely effecting the vacuum pump's performance.

For other brands of vacuum pumps, check with the manufacturer for restrictions and guidelines when using with R-134a.

CAUTION: If you use a vacuum pump with mineral oil to evacuate an R-134a system, it is ABSOLUTELY ESSENTIAL to have a shut-off valve between pump and your manifold gauge set as shown in Figure E4. The hand valve must be closed during all times when vacuum pump is not operating. This will prevent migration of mineral oil vapor into R134a/Ester oil system. If vacuum pump should stop during evacuation for any reason, the hand pump shut-off valve must be closed immediately.

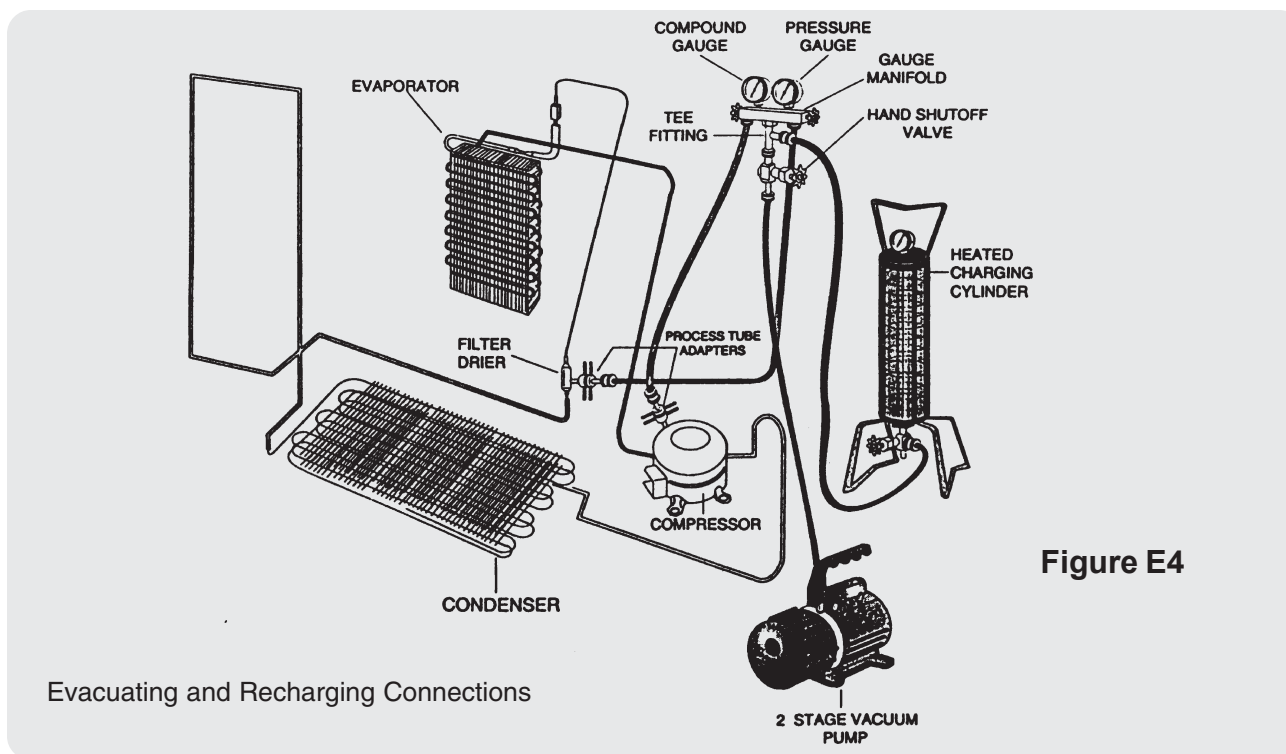

Figure E4

REFRIGERANT LEAKS

A system with R-134a and Ester oil will become saturated with moisture much faster than a system with R-12 and mineral oil. The compressor in an R-134a system will have to be replaced if the product has had a low side leak.

R-134a refrigerant molecules are smaller than R-12 molecules. This means that R-134a will pass more minor leaks and the rate of flow will be greater than for R-12. Therefore, it is now more important than ever to follow good brazing practices. Use a good grade of silver solder. 45% silver solder is recommended.

LEAK DETECTION

R-134a system leaks can be pinpointed by means of an electronic leak detector or by bubble solution.

Electronic leak detectors for R-134a service are currently available from several manufacturers. The least expensive models are non-selective detectors that will detect any type of emission or vapor present, regardless of its chemical composition. Some non-selective detectors designed for use with R-12 may have a much lower sensitivity when used with R-134a. However, newly designed detectors with good R-134a sensitivity are now available. Be sure to consult with the manufacturer before selecting or using a non-selective detector with R-134a.

Halogen-specific detectors use a specialized sensor that allows detection of compounds containing chlorine, fluorine, bromine, and iodine without being activated by other species. The major advantage of this type of

detector is a reduction in the number of “nuisance alarms”. Halogen-specific detectors are generally more expensive than non-selective detectors but feature higher sensitivity.

R-134a PROPERTIES

The properties of R-134a are very similar to those of R12. The principal data for the two refrigerants are shown in the chart below.

	REFRIGERANTS	
	R-12	R-134a
NAME	Dichlorodifluoromethane	1,1,1,2--Tetrafluoromethane
Formula	CCl ₂ F ₂	CH ₂ F-CF ₃
Molecular Weight (g/mol)	120.93	102.3
Ozone Depletion Potential (ODP)	1	0
Global Warming Potential (GWP)	3.1	0.3
Boiling Point °F	-21.6	-15.7
Vapor Pressure (77°F)	80 psig	82 psig
Flammability	None	None
Solubility of Water in Refrigerant (wt% @ 77°F)	0.009	0.11

HFC-134a, CFC-12 PRESSURE TEMPERATURE CHART

°F	°C	HFC-134a	CFC-12		°F	°C	HFC-134a	CFC-12
-60	-51.1	21.8*	19.0*		55	12.8	51.1	52.0
-55	-48.3	20.4*	17.3*		60	15.6	57.3	57.7
-50	-45.6	18.7*	15.4*		65	18.3	63.9	63.8
-45	-42.8	16.9*	13.3*		70	21.1	70.9	70.2
-40	-40.0	14.8*	11.0*		75	23.9	78.4	77.0
-35	-37.2	12.5*	8.4*		80	26.7	86.4	84.2
-30	-34.4	9.8*	5.5*		85	29.4	94.9	91.8
-25	-31.7	6.9*	2.3*		90	32.2	103.9	99.8
-20	-28.9	3.7*	0.6		95	35.0	113.5	108.3
-15	-26.1	0.0	2.4		100	37.8	123.6	117.2
-10	-23.3	1.9	4.5		105	40.6	134.3	126.6
-5	-20.6	4.1	6.7		110	43.3	145.6	136.4
0	-17.8	6.5	9.2		115	46.1	157.6	146.8
5	-15.0	9.1	11.8		120	48.9	170.3	157.7
10	-12.2	12.0	14.6		125	51.7	183.6	169.1
15	-9.4	15.0	17.7		130	54.4	197.6	181.0
20	-6.7	18.4	21.0		135	57.2	212.4	193.5
25	-3.9	22.1	24.6		140	60.0	227.9	206.6
30	-1.1	26.1	28.5		145	62.8	244.3	220.3
35	1.7	30.4	32.6		150	65.6	261.4	234.6
40	4.4	35.0	37.0		155	68.3	279.5	249.5
45	7.2	40.0	41.7		160	71.1	298.4	265.1
50	10.0	45.3	46.7		165	73.9	318.3	281.4

FIGURES WITH ASTERISKS (*) = IN. HG. VACUUM

FIGURES WITHOUT ASTERISKS = PSIG

R-134A HEALTH AND SAFETY INFORMATION

INHALATION TOXICITY

HFC-134a poses no acute or chronic hazard when it is handled in accordance with DuPont recommendations and when exposures are maintained at or below the DuPont Acceptable Exposure Limit (AEL) of 1,000 ppm (8 and 12 hour Time-Weighted Average or TWA).

An AEL is an airborne exposure limit established by DuPont scientists that specifies time-weighted average (TWA) airborne concentrations to which nearly all workers may be repeatedly exposed without adverse effects. The AEL for HFC-134a has the same value as the Threshold Limit Values (TLVs) established for CFC-12 and HCFC-22. TLVs are established by the American Conference of Governmental and Industrial Hygienists (ACGIH).

However, inhaling high concentrations of HFC-134a vapor may cause temporary central nervous system depression with narcosis, lethargy and anesthetic effects. Other effects that may occur include dizziness, a feeling of intoxication and a loss of coordination. Continued breathing of high concentrations of HFC-134a vapors may produce cardiac irregularities (cardiac sensitization), unconsciousness, and with gross overexposure, death. Intentional misuse or deliberate inhalation of HFC-134a may cause death without warning. This practice is **extremely dangerous**.

If you experience any of the initial symptoms, move to fresh air and seek medical attention.

CARDIAC SENSITIZATION

If vapors are inhaled at a concentration of 75,000 ppm, which is well above the AEL, the heart may become sensitized to adrenaline, leading to cardiac irregularities and, possibly, to cardiac arrest. The likelihood of these cardiac problems increases if you are under physical or emotional stress.

Medical attention must be given immediately if exposed to high concentrations of HFC-134a. **DO NOT** treat with adrenaline (epinephrine) or similar drugs. These drugs may increase the risk of cardiac arrhythmias and cardiac arrest. If the person is having difficulty breathing, administer oxygen. If breathing has stopped, give artificial respiration.

SPILLS OR LEAKS

If a large release of vapor occurs, such as from a large spill or leak, the vapors may concentrate near the floor or low spots and displace the oxygen available for breathing, causing suffocation.

Evacuate everyone until the area has been ventilated. Use blowers or fans to circulate the air at floor level. **DO NOT** reenter the affected area unless you are equipped with a self-contained breathing apparatus or unless an area monitor indicates that the concentration of HFC-134a vapors in the area is below the AEL.

Always use self-contained breathing apparatus or an air-line mask when entering tanks or other areas where vapors might exist. Use the buddy system and a lifeline. Refer to the Material Safety Data Sheet (MSDS) for HFC-134a for more information.

HFC-134a vapors have a slightly sweet odor that can be difficult to detect. Therefore, frequent leak checks and the installation of permanent area monitors may be necessary in enclosed spaces. Refer to ASHRAE Standards 15 and 34 for refrigeration machinery rooms.

To ensure safety when working with HFC-134a in enclosed areas:

1. Route relief and purge vent piping (if present) outdoors, away from air intakes.
2. Make certain area is well ventilated, using auxiliary ventilation, if necessary, to move vapors.
3. Ensure that area is clear of vapors prior to beginning work.
4. Install air monitoring equipment to detect leaks.

SKIN AND EYE CONTACT

At room temperature, HFC-134a vapors have little or no effect on the skin or eyes. However, in liquid form, HFC-134a can freeze skin or eyes on contact, causing frostbite. Following contact, soak the exposed area in lukewarm water, not cold or hot. If medical treatment cannot begin immediately, apply a light coat of a nonmedicated ointment, such as petroleum jelly. If the exposed area is in a location where the presence of the ointment would be awkward, such as on the eye, apply a light bandage. In all cases of frostbite, seek medical attention as soon as possible.

Always wear protective clothing when there is a risk of exposure to liquid HFC-134a. Where splashing is possible, **always** wear eye protection and a face shield.

COMBUSTIBILITY OF HFC-134a

HFC-134a is nonflammable at ambient temperatures and atmospheric pressure. However, tests have shown HFC-134a to be combustible at pressures as low as 5.5 psig (139.3 kPa absolute) at 177°C (350°F) when mixed with air at concentrations generally greater than 60% volume air. At lower temperatures, higher pressures are required for combustibility. (HCFC-22 is also combustible at pressures above atmospheric in the presence of high air concentrations). Test results and calculations have shown:

- At ambient temperature, all concentrations of HFC-134a in air are nonflammable at pressures below 15 psig (205 kPa absolute).
- Combustible mixtures of air and HFC-134a will not form when liquid HFC-134a is pumped into closed vessel if initial air pressure in vessel is limited to one atmosphere absolute and final pressure is limited to 300 psig (2,170 kPa absolute). If initial air pressure is greater than one atmosphere, combustible mixtures may form as tank is filled.

Based on above information, the following operating practices are recommended:

Leak Testing

- Equipment should **NEVER** be leak tested with a pressurized mixture of HFC-134a and air. HFC-134a may be safely pressured with dry nitrogen.

Bulk Delivery and Storage

- Tanks should normally be evacuated at start of filling, and should never be filled while under positive air pressure.
- Tank pressure should never be allowed to exceed 300 psig (2,170 kPa) when filling with HFC-134a. Relief devices on either tanks or HFC-134a supply system usually prevent this.
- Tank pressures should be monitored routinely.
- Air lines should never be connected to storage tanks.

Filling and Charging Operations

- Before evacuating cylinders or refrigeration equipment, any remaining refrigerant should be removed by recovery system.
- Vacuum pump discharge lines should be free of restrictions that could increase discharge pressures above 15 psig (205 kPa) and result in formation of combustible mixtures.
- Cylinders or refrigeration equipment should normally be evacuated at start of filling, and should never be filled while under positive air pressure.
- Final pressures should not exceed 300 psig (2,170 kPa).
- Filled cylinders should periodically be analyzed for air (nonabsorbable gas or NAG).

Refrigerant Recovery Systems

Efficient recovery of refrigerant from equipment or containers requires evacuation at the end of the recovery cycle. Suction lines to a recovery compressor should be periodically checked for leaks to prevent compressing air into the recovery cylinder during evacuation. In addition, the recovery cylinder pressure should be monitored, and evacuation stopped in the event of a rapid pressure rise indicating the presence of noncondensable air. The recovery cylinder contents should then be analyzed for NAG, and the recovery system leak checked if air is present. **DO NOT** continue to evacuate a refrigeration system that has a major leak.

THERMAL DECOMPOSITION

HFC-134a vapors will decompose when exposed to high temperatures from flames or electric resistance heaters. Decomposition may produce toxic and irritating compounds, such as hydrogen fluoride. The pungent odors released will irritate the nose and throat and generally force people to evacuate the area. Therefore, it is important to prevent decomposition by avoiding exposure to high temperatures.

SECTION F - ICE MAKER

ICE MAKER FOR TOP MOUNT MODELS

The automatic Ice Maker is mounted in the freezer compartment. It is attached to the freezer compartment's left wall with two screws and can be removed for servicing.

The Ice Maker is designed to produce ice automatically. The length of time between Harvest Cycles will vary, depending on load conditions, door openings, ambient temperature and freezer temperature. These factors must be taken into consideration when checking the ice production rate.

With a temperature of -2°F to $+5^{\circ}\text{F}$ in the freezer, the rate of harvest will be 8 - 12 cycles per 24 hour period.

The Ice Maker is wired across the line and will harvest ice in the refrigeration or defrost cycles.

The Water Valve and Solenoid Assembly are both mounted in the compressor compartment.

A $3/16$ " polyethylene tube extends from the water valve up the rear wall of the refrigerator to a water inlet spout that directs the water into the fill trough. A bead of sealer around the inlet water tube prevents the migration of air and moisture into the freezer compartment.

Front Cover

A decorative front cover, made of molded plastic, encloses the operating mechanism of the Ice Maker, protecting it from moisture. It is essential that the cover be in place on an operating Ice Maker to protect against possible contact with the mechanism by the user. (See Figure F1)

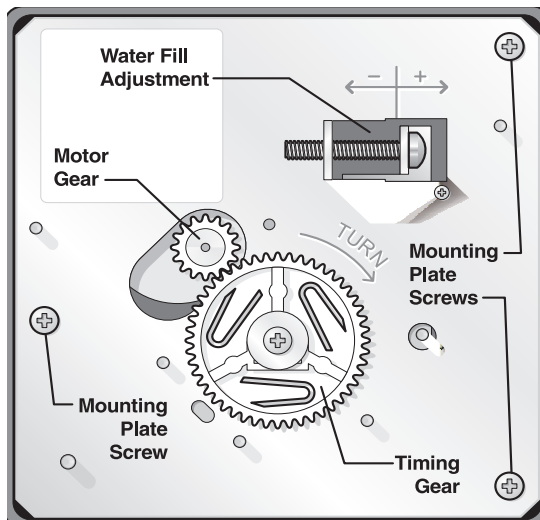

Figure F1

ICE MAKER COMPONENTS

Ice Mold

The Ice Mold is die-cast aluminum with the Ice Maker Thermostat bonded to its front surface. The Mold has a semi-circular interior partitioned into equal size compartments. Water enters at the rear of the Mold, through a fill trough. A film of silicon grease on the top edge of the Mold prevents siphoning of water by capillary action.

Mold Heater

A Mold Heater, rated at 115volts, 81 ohms $\pm 10\%$ or 230 volts, 340 ohms $\pm 10\%$, and covered with an aluminum sheath, is embedded in the grooved section on the underside of the Mold. When the Mold Heater is energized, the ice contact surface within the Mold is heated enough to allow harvest of the ice pieces.

The Mold Heater is wired in series with the Ice Maker Thermostat, which acts as a safety device.

The original heater is staked in place, but can be removed for replacement. The replacement heater is secured to the Mold by four flat head retaining screws that thread into holes in the Mold, adjacent to the heater.

A thermal mastic sealer is placed between the heater and the Mold to ensure good thermal contact.

Ice Stripper

An Ice Stripper is attached to the Mold to prevent ice pieces from falling back into the Mold. It also serves as a decorative side cover.

Ice Ejector

The Ejector blades are molded from Delrin, and extend from a central shaft, which turns in nylon bearings at the front and rear. Each blade sweeps an ice section out of the Mold. The drive end of the Ice Ejector is "D" shaped. Silicone grease is used to lubricate the bearing surfaces.

Water Valve Assembly

The Water Valve is solenoid operated and when energized, releases water from the supply line into the Ice Mold. The amount of water released is directly proportional to the length of time the Water Valve Switch is energized. A flow washer, inside the Water Valve, maintains a constant rate of water flow over a supply line pressing ranging from 15 to 100 psig. It will not compensate for pressures below 15 psig, or greater than 100 psig. A No. 80-mesh screen, placed ahead of the flow washer, filters out foreign materials.

The solenoid coil draws 10 to 115 watts of power. The coil is wired in series with the Mold Heater, across the supply voltage.

Thermostat

The Thermostat is a single-pole, single throw (SPST), bimetallic, disk-type, thermal switch. It automatically starts the Harvest Cycle when the ice is frozen. The Thermostat closes at a temperature of 18°F ± 6°. Wired in series with the Mold Heater, the Thermostat acts as a safety device against overheating in the event of mechanical failure. A thermal mastic bond is provided where the Thermostat is mounted against the Mold. A gasket prevents water from leaking into the support housing.

Sensing Arm & Linkage

The Sensing Arm is cam-driven and operates a switch that controls the quantity of ice produced. In the Harvest Cycle, the arm is raised and lowered during each of the two revolutions of the timing cam. If the Sensing Arm comes to rest on top of ice in the storage compartment during either revolution, the switch will remain open and stop the Ice Maker at the end of that revolution. When sufficient ice is removed from the Storage Container, the Sensing Arm lowers and ice production resumes. To manually stop the Ice Maker, raise the Sensing Arm until it locks in the upper position. Operation is resumed when the Sensing Arm is manually lowered.

Timing Switches (See Figure F2)

The three Timing Switches used are single-pole, double throw (SPDT). They are identical except for function, and can be used interchangeably.

1. **Hold Switch** - Assures completion of a revolution once the Ice Maker operation has started.
2. **Water Fill Switch** - Opens the Water Valve during the Fill Cycle. It is the only adjustable component in the Ice Maker.
3. **Shut-Off Switch** - Stops Ice Maker operation when the Storage Container is full of Ice. The switch is opened after the Sensing Arm is raised to its most upright position. The switch is mounted to the top right wall of the Ice Maker Support. (Not shown in Figure F2)

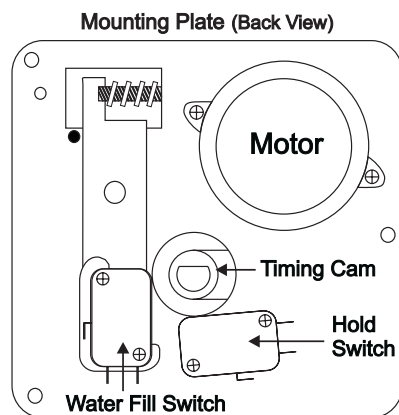

Figure F2

Thermal Cut-Out (TCO)

The Thermal Cut-Out is a one-time limit fuse used as a safety device. It is located under the mounting plate, in the head of the Ice Maker, between the Thermostat and wire connector.

If the Thermal Cut-Out opens, the cause of failure must be determined and corrected prior to replacing the TCO. Normal causes of the TCO failing are a bad Thermostat or a shorted coil on the water valve.

Timing Cam & Coupler

Three separate cams are combined in one molded Delrin part:

1. Inner Cam operates Shut-Off Switch lever arm.
2. Center Cam operates Hold Switch.
3. Outer Cam operates Water Fill Switch.

One Cam end is attached to a large Timing Gear. The other Cam end is coupled to the Ejector.

Timing Gear

This large molded plastic gear is driven by the Motor and, in turn, rotates the Cam and Ejector. A "D" shaped hole in the gear fits over the Timing Cam Hub. Spacer tabs on the backside of the gear prevent the gear from binding on the mounting plate.

Motor

A low wattage, stall-type Motor drives the Timing Gear. This gear turns the Timing Cam and Ejector Blades approximately one revolution every three minutes (1/3 RPM).

Fill Trough

The Fill Trough is molded nylon. It supports the Inlet Tube and directs the water into the Mold. It also forms a bearing for one end of the Ejector Blades.

Wiring

A four-prong plug connects the Ice Maker wiring to the cabinet wiring harness. (See Figure F3.) The Ice Maker Assembly is wired across the line and will harvest in either the Refrigeration or Defrost Cycles. A wiring diagram is located inside the front cover of the Ice Maker.

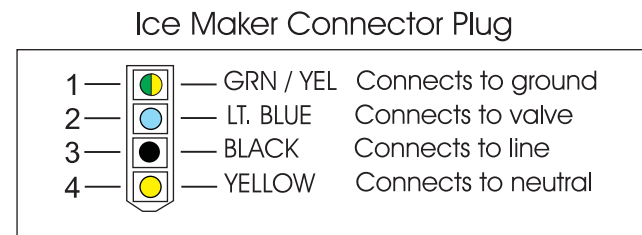

Figure F3

INSTALLING WATER SUPPLY LINE TO ICE MAKER

Supply line installation must comply with all applicable plumbing codes. Refer to the **Ice Maker Installation Instructions**.

The ¼" tubing, and any other plumbing materials required, should be obtained locally.

The Ice Maker should be connected to a frequently used cold water line to ensure a fresh water supply.

NOTE: A vertical cold water line should be selected for the water supply. If a vertical line is not available, a horizontal line may be used, providing the connection is on the side or top of the pipe, but **not on the bottom**. Scale and foreign material in the pipe could cause stoppage of water flow if the connection is on the bottom.

Be sure to leak test all connections after the water supply has been turned on.

TEST CYCLING ICE MAKER (See *Ice Maker Testing Procedures* on pages 59-68).

It may be necessary, on occasion, to test-cycle an Ice Maker to check its operation. This can be done on the repair bench or while mounted in the Refrigerator.

If the Ice Maker is in an operating refrigerator, take precautions against the formation of condensate by allowing the cold, metal components to warm up before removing the front cover. This can be expedited by cycling the assembly with the cover in place and the water supply valve closed.

To manually cycle the Ice Maker, slowly turn the Ejector blades clockwise until the Hold Switch circuit to the Motor is completed. When the Motor starts, all components except the Ice Maker Thermostat should perform normally. Once the Ice Maker completes its cycle, remove the front Cover; see instructions for replacing the front Cover in "**To Replace Front Cover**" on this page.

If further test cycling is necessary, place screwdriver blade in slot located in the Motor Drive Gear and turn counterclockwise until the Hold Switch circuit to the Motor is completed.

WATER VALVE SWITCH – WATER FILL VOLUME

The amount of water fill is directly proportional to the length of time terminals "C-NC" of the Water Fill Switch are closed. Closing occurs when the switch plunger drops into a cavity formed in the Cam.

Different water valves have different flow rates. For this reason, anytime a Water Valve is replaced, the Water Fill Switch must be adjusted.

The correct water fill volume is 95-105 cc. To measure the fill volume, test-cycle the Ice Maker and collect the water. Measure in a container calibrated in cubic centimeters (cc) or ounces.

The fill volume is adjusted by increasing or decreasing the length of time the Water Fill Switch remains closed.

To adjust the Water Fill Switch, first determine how much water is needed. The adjusting screw is calibrated so that one complete revolution changes the water fill about 18 cubic centimeters. Turning the screw clockwise decreases the fill, while turning counterclockwise increases the fill.

EXAMPLE: An Ice Maker is test-cycled and the water fill sample is 158 cubic centimeters. Subtracting 145 cc from 158, the adjustment needed is 13 cc. Since one turn of the adjusting screw changes the fill 18 cc, ¾ of a turn clockwise would reduce the fill about 13 cc, the desired amount. (This example is for manual models only.)

PARTS REPLACEMENT

Disconnect electrical supply to refrigerator. If the Refrigerator is operating and cold, allow the Ice Maker to warm up to room temperature before removing the front cover. This prevents moisture from condensing on the metal components.

To Replace Front Cover (See Figure F4)

1. Ensure that Ice Maker is at room temperature before removing Cover.
2. Place straight blade of screwdriver in slot at bottom of Mold Support and pry Cover loose.

NOTE: Ensure that the retaining tabs inside the Cover are located on the top and bottom when installing the Cover.

3. Snap Cover in place.

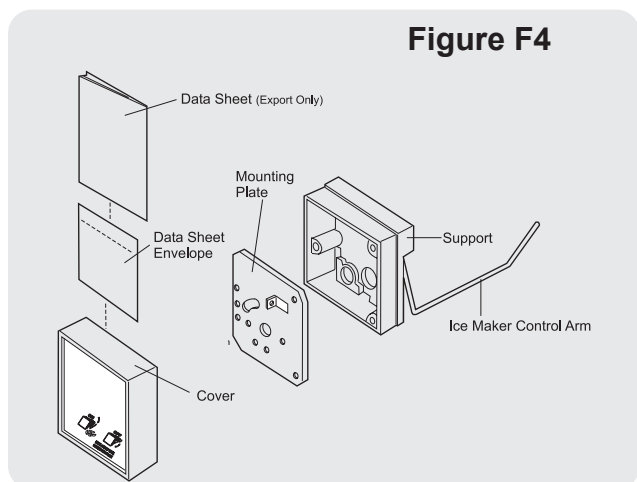

To Replace Fill Trough and Bearings

1. Push Trough retaining tab back away from Mold.
2. Rotate Trough counterclockwise until it is clear.
3. Pull from back to detach from Mold and Ejector Blades.
4. Replace in reverse order.

To Replace Ice Stripper

1. Remove Ice Maker from refrigerator.
2. Remove retaining screw at back of mold.
3. Pull back on Ice Stripper to disengage it from front of Mold Support housing.
4. Replace in reverse order.

To Replace Ejector Blades

1. Remove front Cover.
2. Remove three screws holding Mounting Plate in place.
3. Carefully remove Mounting Plate, disengaging end of Ice Maker Control Arm and Ejector Blades from Motor coupling, noting relative position of Ice Maker Control Arm Spring.
4. Remove Fill Trough and bearing.
5. Turn blades to 12 O'clock position.
6. Slide Ejector Blades back and up to remove.
7. Replace in reverse order.
8. Lubricate bearing ends of Ejector with Silicone grease.

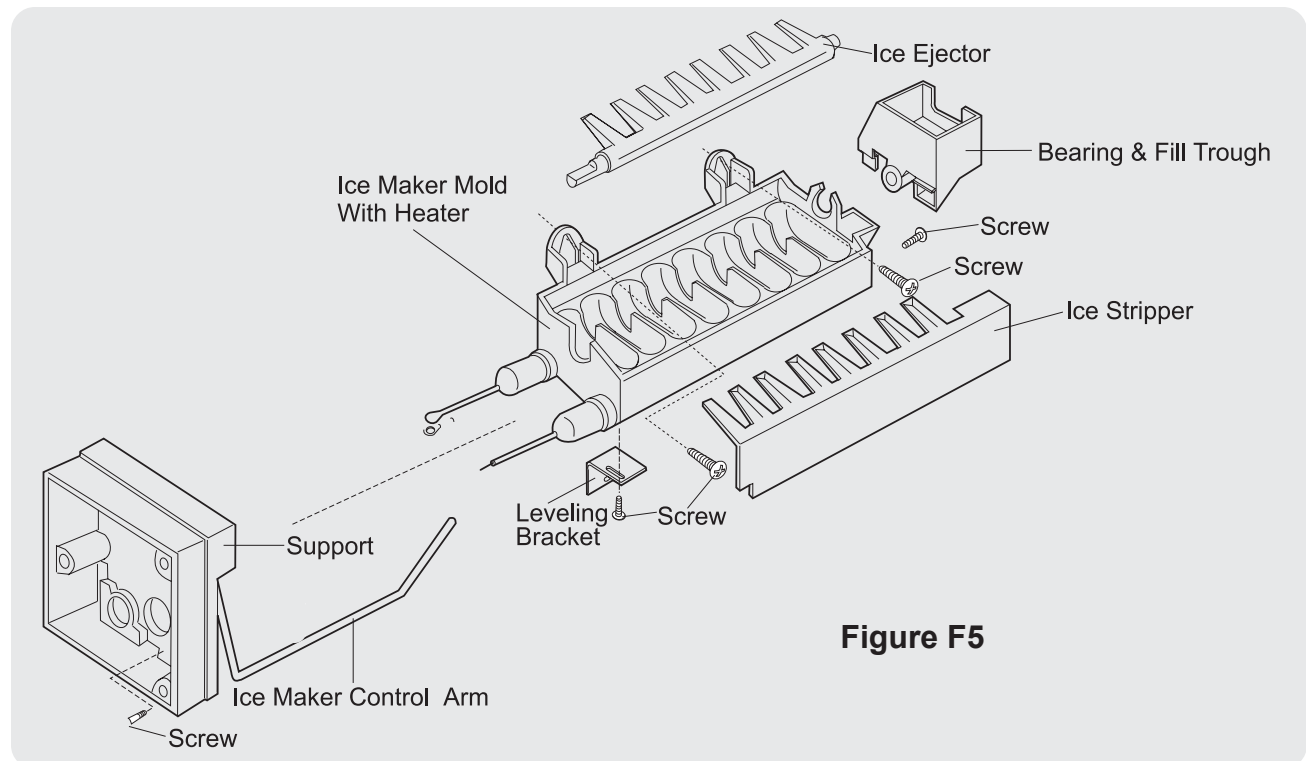

Figure F5

To Replace Motor and Switch Mounting Plate

1. Remove front Cover.
2. Remove three screws that attach Mounting Plate to Support Housing.
3. Carefully remove Mounting Plate, disengaging end of Sweep Arm and noting relative position of Sweep Arm Spring.
4. Transfer Motor, Switches, Cam, Gear, and Water Fill Adjusting Spring and Arm to replacement Mounting Plate.
5. Attach new Mounting Plate to Support Housing with three screws.

NOTE: Ensure that the wiring harness is properly positioned and the Sweep Arm is in place.

6. Check Water Fill Cycle and adjust as required.
7. Replace front Cover.

To Replace Motor

1. Remove front Cover.
2. Remove three screws that attach Mounting Plate to Support Housing.
3. Disconnect two Motor leads.
4. Remove two Motor mounting screws.
5. Replace Motor in reverse order.

To Replace Water Fill Switch

1. Remove front Cover.
2. Remove three screws that attach Mounting Plate to Support Housing.
3. Disconnect two Water Fill Switch wire leads.
4. Remove two switch mounting screws.
5. Remove switch.
6. Replace switch in reverse order, ensuring that switch insulator is in place.
7. Check Water Fill Cycle and adjust as required.

To Replace Hold Switch

1. Remove front Cover.
2. Remove three screws that attach Mounting Plate to Support Housing.
3. Disconnect six Hold Switch wire leads.
4. Remove two Hold Switch mounting screws.
5. Remove Hold Switch.
6. Replace in reverse order.

To Replace Ice Maker Control Arm Shut-OFF Switch

1. Remove front Cover.
2. Remove three screws that attach Mounting Plate to Support Housing.
3. Disconnect three Ice Maker Control Arm Shut-Off Switch wire leads.
4. Raise Ice Maker Control Arm Lever.
5. Remove two Ice Maker Control Arm Shut-Off Switch mounting screws.
6. Remove switch.
7. Replace switch in reverse order.

To Replace Ice Maker Thermostat

1. Remove front Cover.
2. Remove three screws that attach Mounting Plate to Support Housing.
3. Loosen two Thermostat retaining clip mounting screws.
4. Disconnect two thermostat wire leads and remove thermostat.
5. Apply thermal mastic sealer to sensing surface of replacement thermostat to ensure a positive bond to mold.
6. Replace thermostat in reverse order.

To Replace Thermal Cut-Out (TCO)

1. Remove front Cover.
2. Remove three screws that attach Mounting Plate to Support Housing.
3. Pull cable assembly free from support housing. It will slide out easily.
4. Loosen screw securing clamp to TCO. TCO should come free after tension from clamp is released.
5. Disconnect TCO from two wire nuts. One end is connect to the cable assembly and the other end is connected to the motor and mold heater.
6. Replace with new TCO.
7. Reassemble in reverse order.

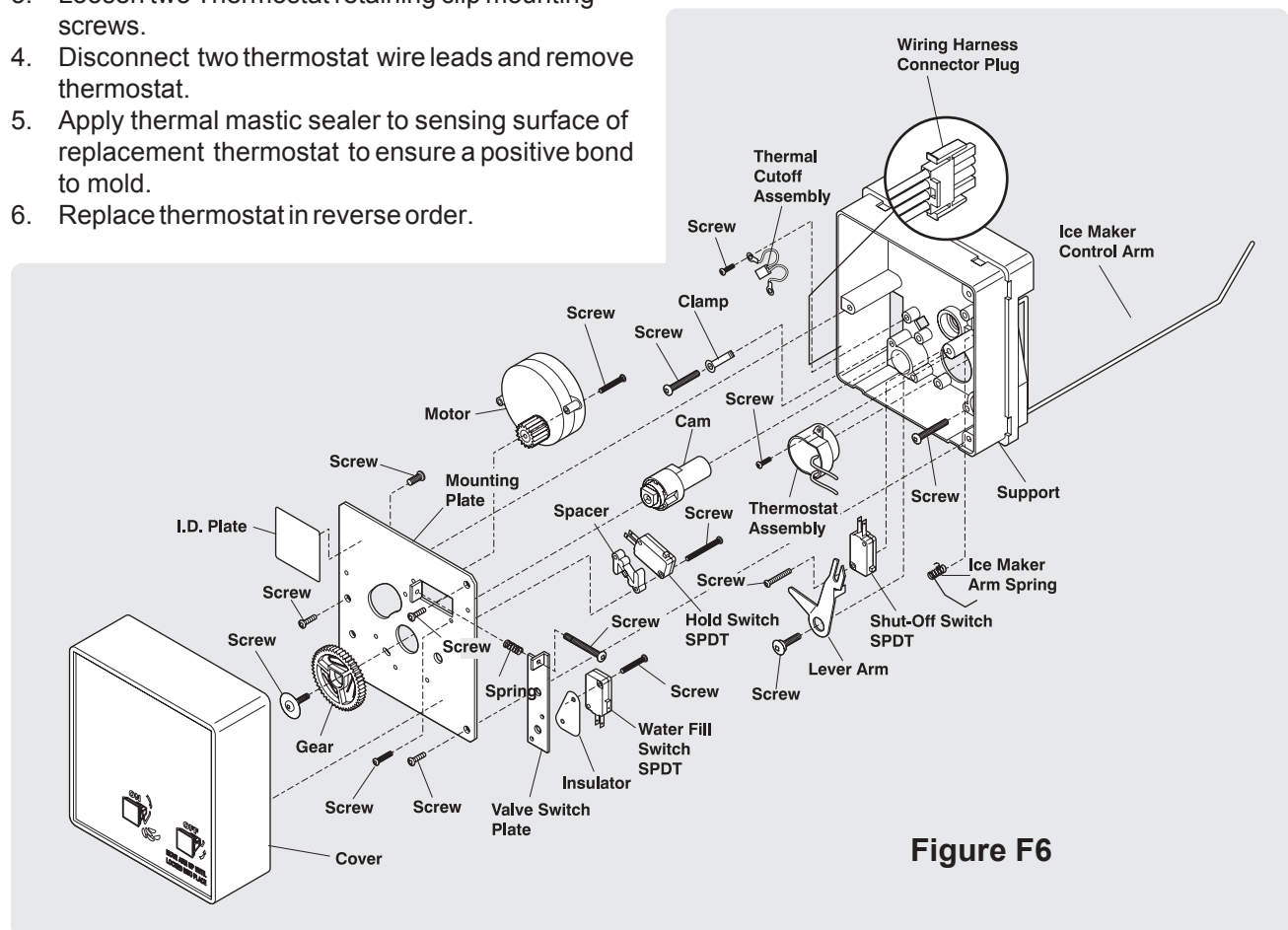

Figure F6

To Replace Mold Heater

1. Remove front Cover.
2. Remove Ice Stripper. (Refer to Section "To Replace Ice Stripper" on page 56)
3. Remove three screws that attach Mounting Plate to Support Housing.
4. Remove three screws that attach Mold to Support Housing.

NOTE: One of the three screws is attached to the two Green/Yellow ground wires and another one is holding the Clamp in place. The third screw is located in the lower right corner of the Support Housing.

5. Unscrew wire nut holding three black leads together and separate them.

NOTE: One black lead is connected to the Mold Heater. Another is connected to the Thermostat and the third lead goes to the Hold Switch.

6. Disconnect remaining Mold Heater lead connected to brown Motor lead and black Thermal Cut-Out lead.
7. Separate Mold from Support Housing.

NOTE: Be careful not to destroy the thermostat gasket located between the mold and support housing.

8. Remove hex head screw holding Ice Maker Leveling Bracket to Mold.

NOTE: The Mold is crimped in six places, holding the Mold Heater firmly in the Mold groove. It may be necessary to use a hammer and screwdriver to remove the heater from the Mold groove.

9. Use a flat-bladed screwdriver to pry inoperative heater from Mold groove.
10. Clean remaining thermal mastic sealer from Mold groove.
11. Apply layer of thermal mastic sealer to Mold groove.
12. Install replacement Mold Heater.
13. Replace parts in reverse order. Ensure that Thermostat gasket is in place. Bond the Thermostat to Mold with thermal mastic sealer.

NOTE: For best operation, the freezer temperature should be between -2°F to +4°F.

FAULT DIAGNOSIS

Complaint - Ice Maker Fails to Start

1. Check to see if Ice Maker Control Arm is locked in raised position.
2. Check terminals from Cabinet wiring to Ice Maker for open circuit in wiring or components.
3. Check operation of the Maker with test service cord.

4. Check Mold temperature at a mounting screw. If temperature is above 15°F, freezer air temperature is not cold enough to switch Ice Maker Thermostat to closed position. If Mold is below 9°F, manually start Ice Maker by rotating Timer gear. If motor fails to start, check Motor for continuity. If Motor starts, Thermostat, Shut-Off Switch, or Hold Switch is inoperative.
5. Check Hold Switch first. With Ejector blades in the starting position, check terminals "C" and "NC" for continuity. Replace switch if continuity readings are open. Check Shut-Off Switch linkage. Then check terminals "NO" and "C" for continuity with Ice Maker Control Arm in lowest position. Replace switch if continuity readings are open. If Hold Switch and Shut-Off Switch are operative, then replace Thermostat.

Complaint-Ice Maker Fails to Complete Cycle.

1. With Ejector blades at 10 o'clock position, Hold Switch Plunger depressed, Check terminals "C" and "NO" for continuity. Replace switch if continuity readings are open.
2. With Ejector blades at 12 o'clock position, check Shut-Off Switch terminals "C" and "NC" for continuity. Replace Thermostat if continuity readings are open.
3. With Ejector blades at 4 o'clock position, check Mold Heater and Ice Maker Thermostat for continuity. Replace heater if continuity readings are open. If heater shows continuity, replace Thermostat.
4. Check Motor operation with a test cord. Replace Motor if it fails to start.

Complaint-Ice Maker Fail to Stop at End of Cycle

With the Ejector blades in the starting position, check the Hold Switch terminals "C" and "NO" for continuity. Replace the switch if the continuity readings are indicating a closed circuit.

Complaint-Ice Maker Continues to Eject When Container is Full.

1. Check for loose linkage to the Ice Maker Control arm Shut-Off Switch. Switch should open when arm is in raised position. Adjust, if required.
2. Check Shut-Off Switch terminals "C" and "NO" for continuity with Ice Maker Control Arm raised. Replace switch if continuity readings are indicating a closed circuit.

Complaint-Ice Maker Produces Undersized Ice Pieces

1. Ensure that Ice Maker mold is level.
2. Check for partial restriction in supply line or Water Valve Strainer.
3. Ensure that the water pressure to Water Valve is sufficient. (30 psi min., 100 psi max.)
4. Ensure that the Water Valve Switch is adjusted for proper water fill, 90-105 cc's.
5. Check thermal bond between Thermostat and Mold. If necessary, rebond with thermal mastic sealer.

ICE MAKER TESTING PROCEDURES

Operating Cycle

The operation of the Ice Maker, water refilling, and controlled ice storage, require proper functioning and timing of all components.

Consider the following:

- Has refrigerator been properly installed and connected to sources of electrical power and water?
- Has Freezer compartment Evaporator pulled down to temperature?
- Have several ice making cycles been completed and is the Ice Maker in the Freeze Cycle?
- Is the Ice Maker Thermostat single-throw switch in series with the Mold Heater?
- Do the Ejector Blades make two revolutions per cycle? Is ice stored on blades after harvest?
- Is the Water Solenoid wired in series with the Mold Heater?

Operating Cycle Illustrations - Manual Cycle

To manually cycle Ice Maker:

1. Remove Cover from Ice Maker head.
2. Insert a Phillips® into screw on timing gear.
3. Turn gear clockwise until Motor starts to run.

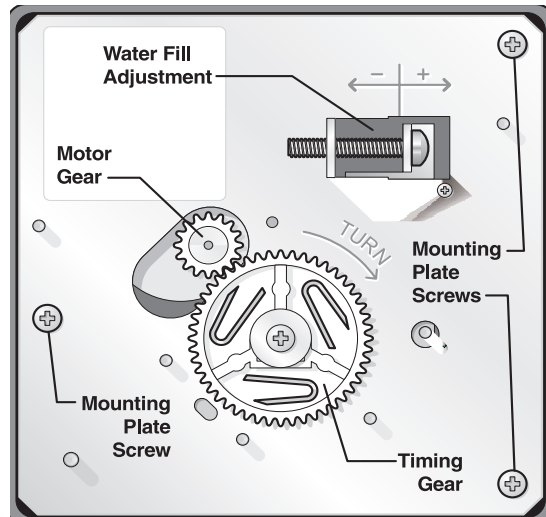

Operating Cycle Illustrations - Electrical

The following wiring diagrams illustrate the electrical operation of an Ice Maker.

This procedure is on the Internet at <http://www.frigidaire.com/tip/>

USER NAME: service

PASSWORD: tips

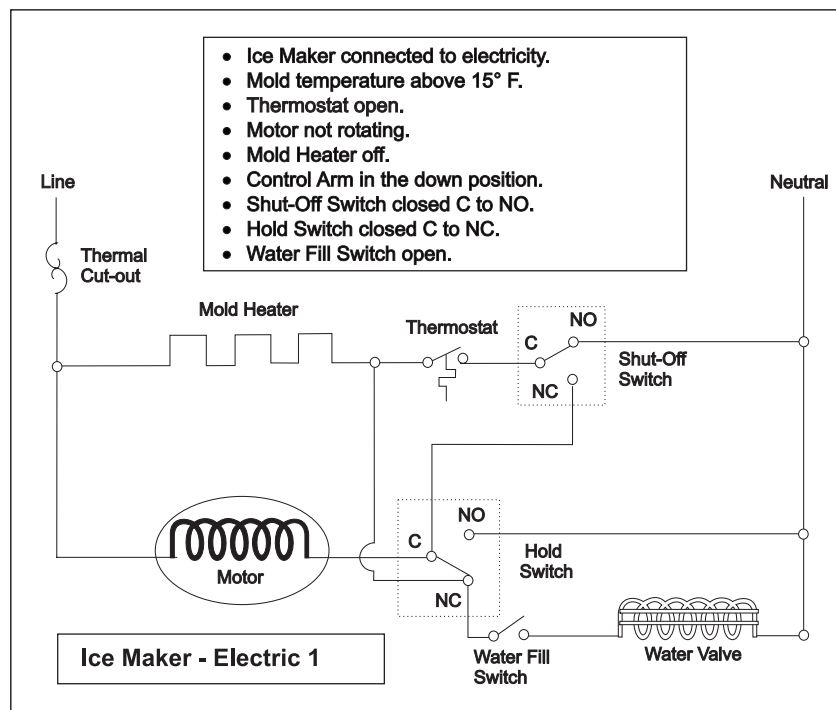

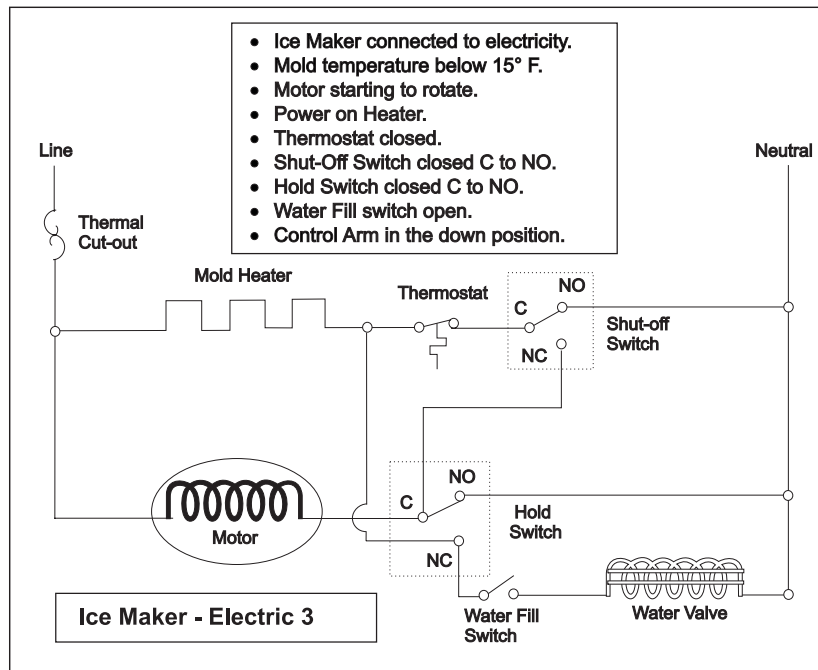
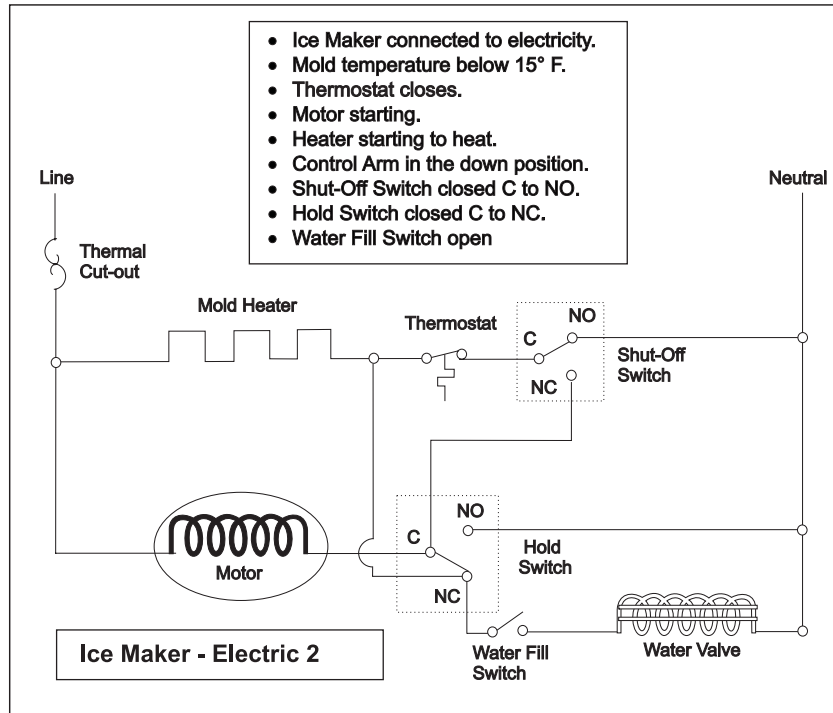

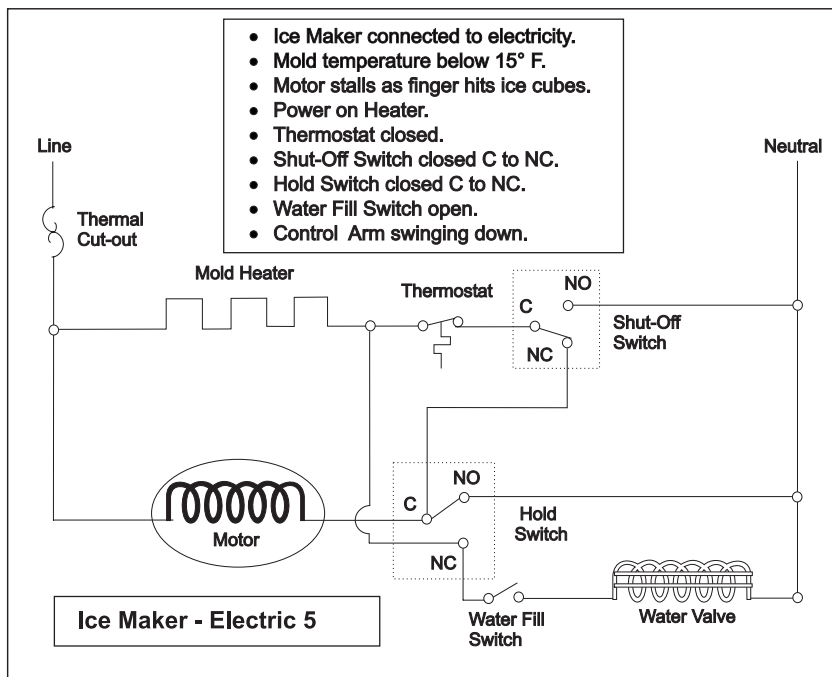
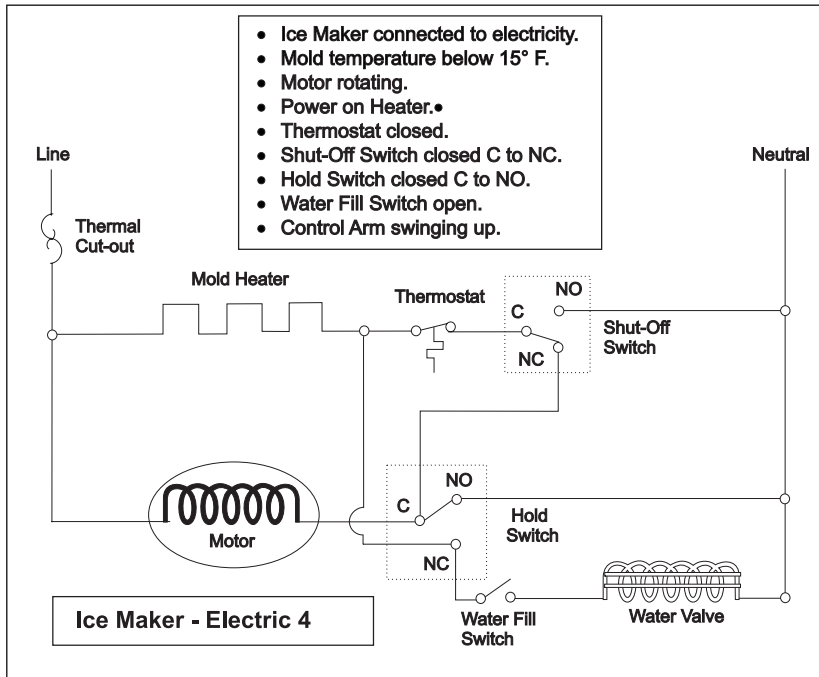

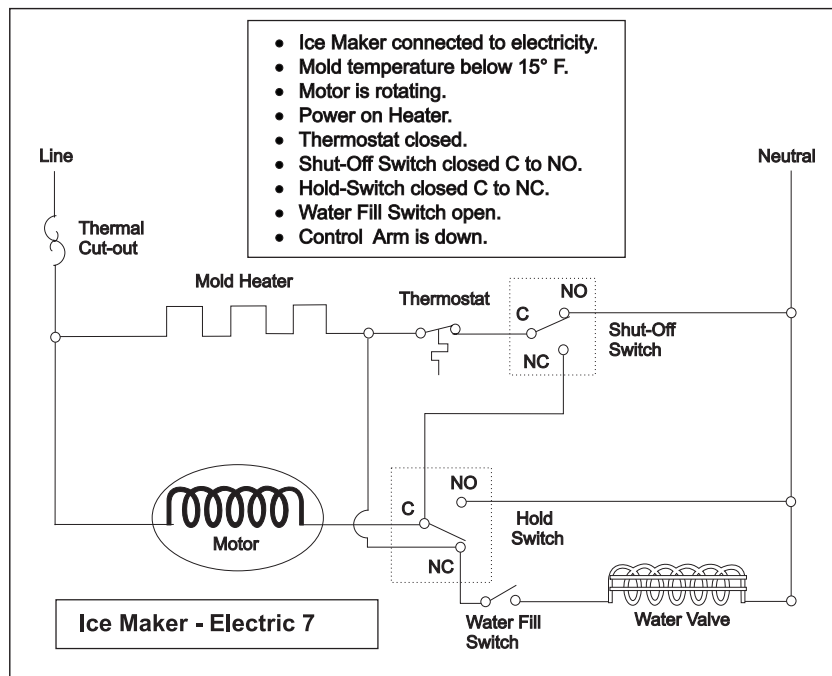
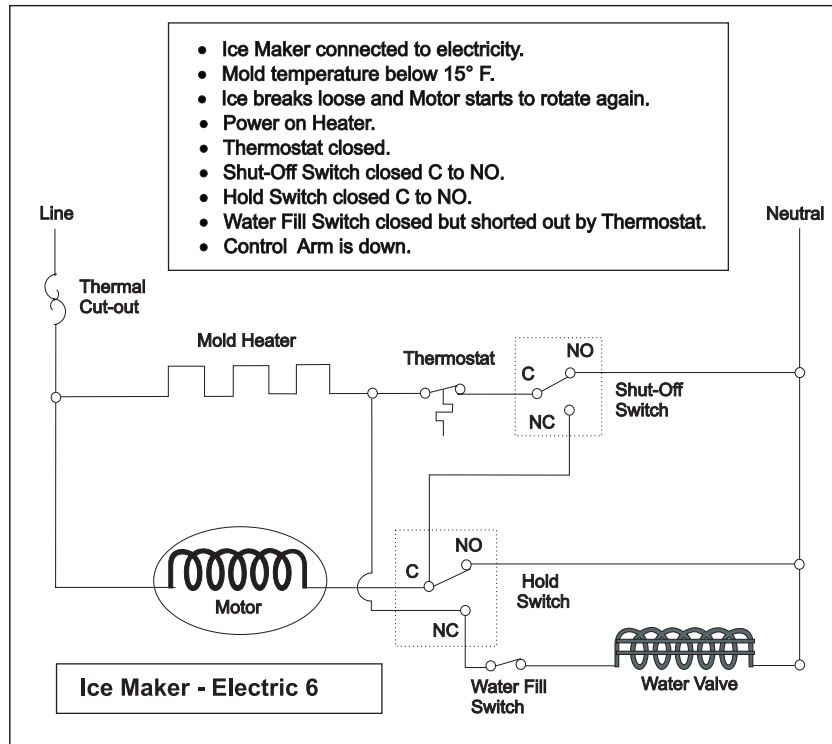

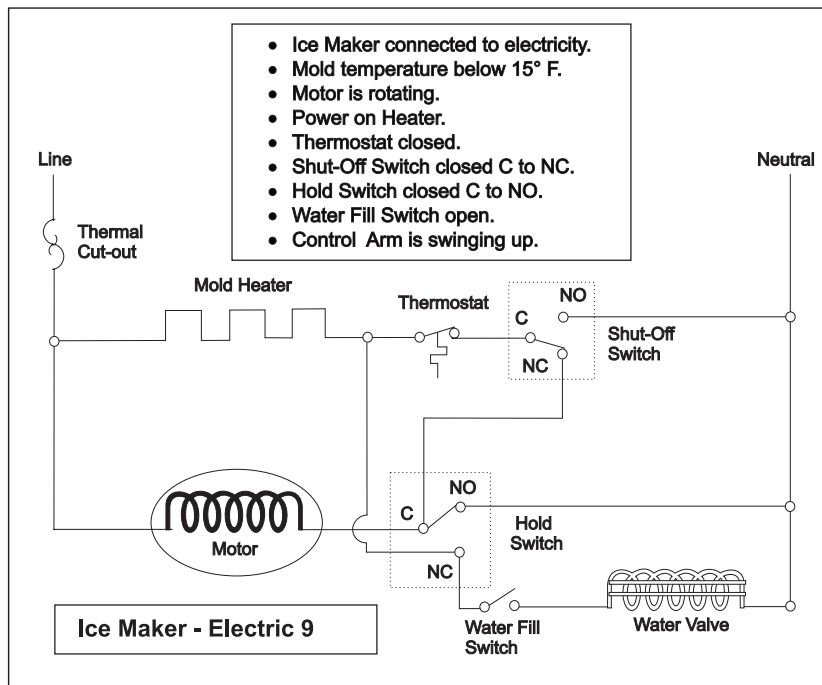
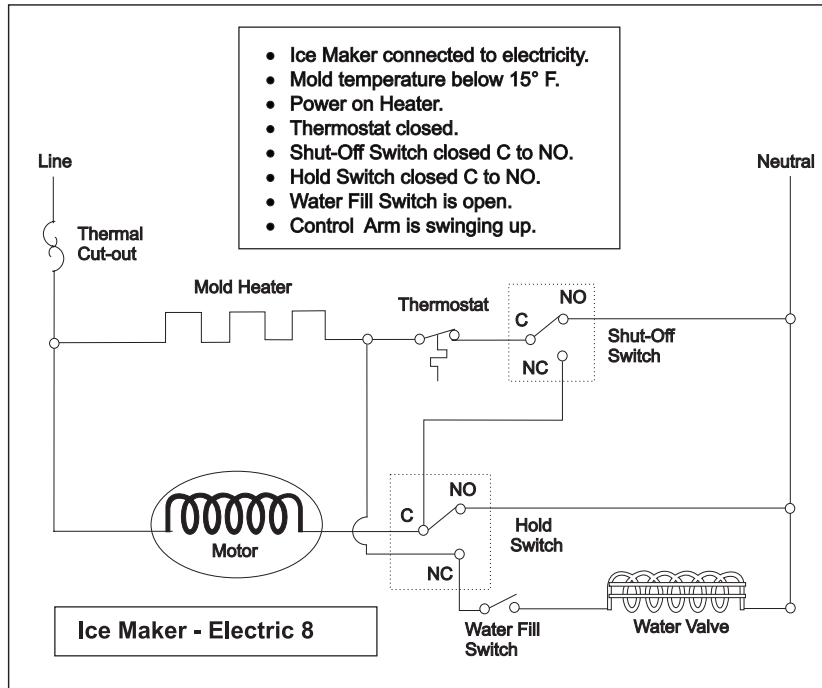

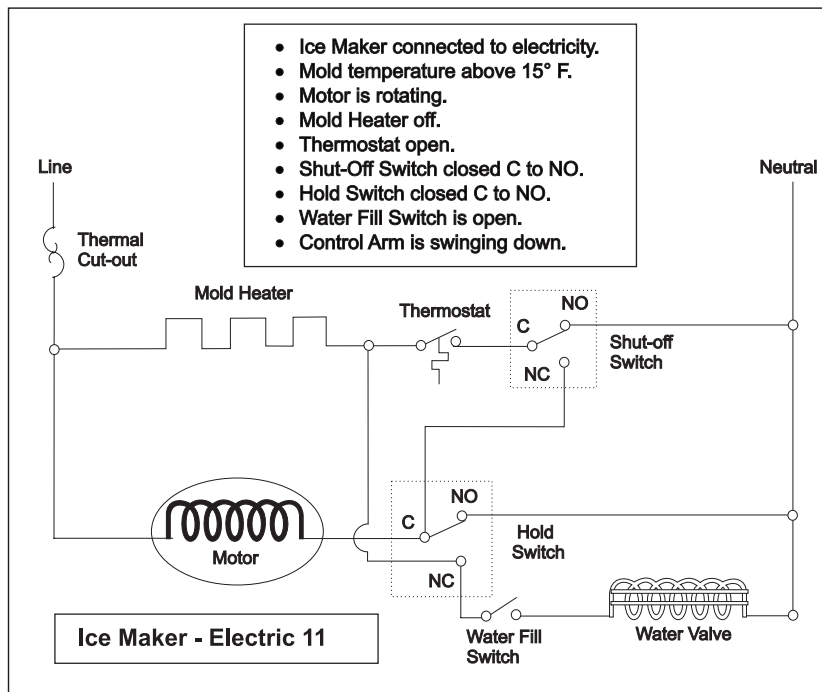
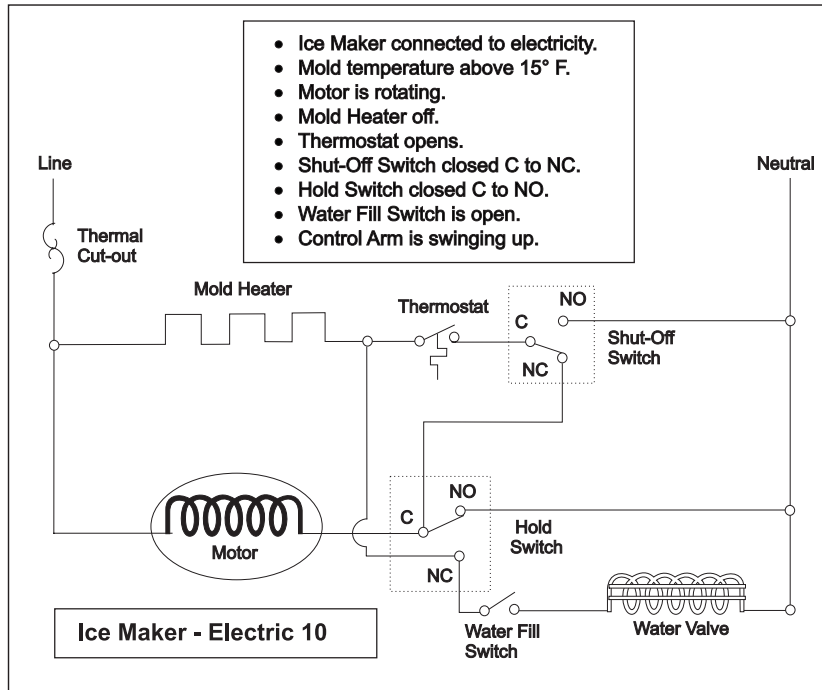

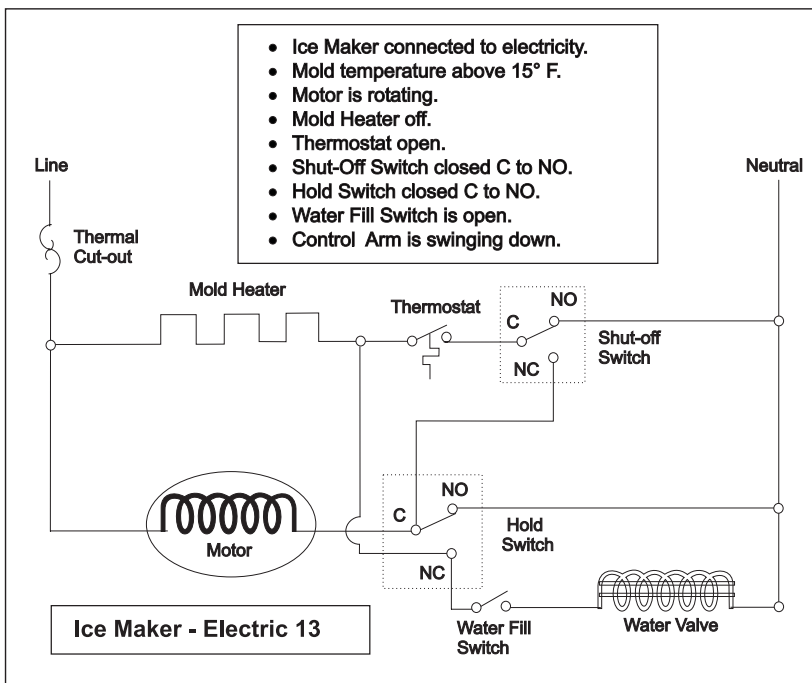
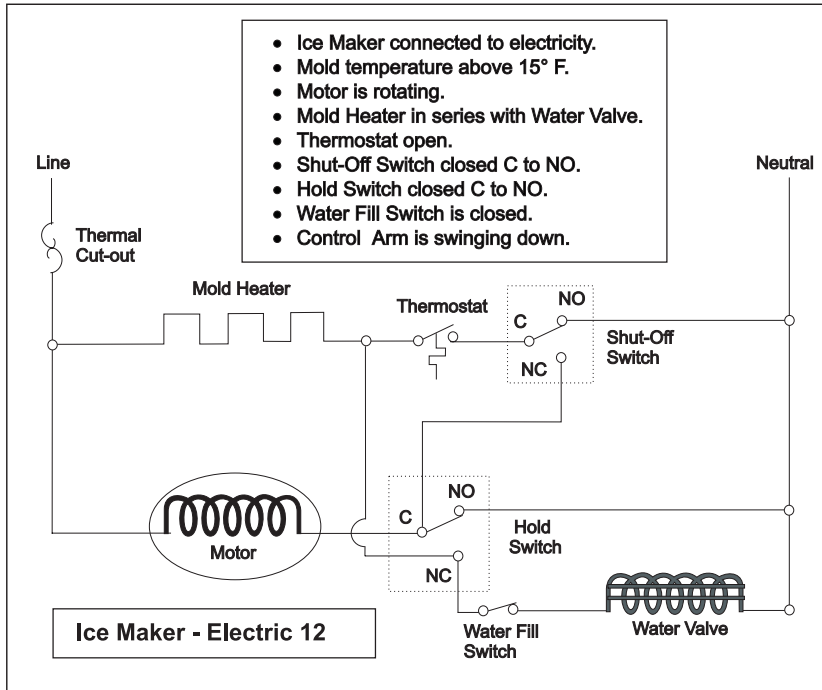

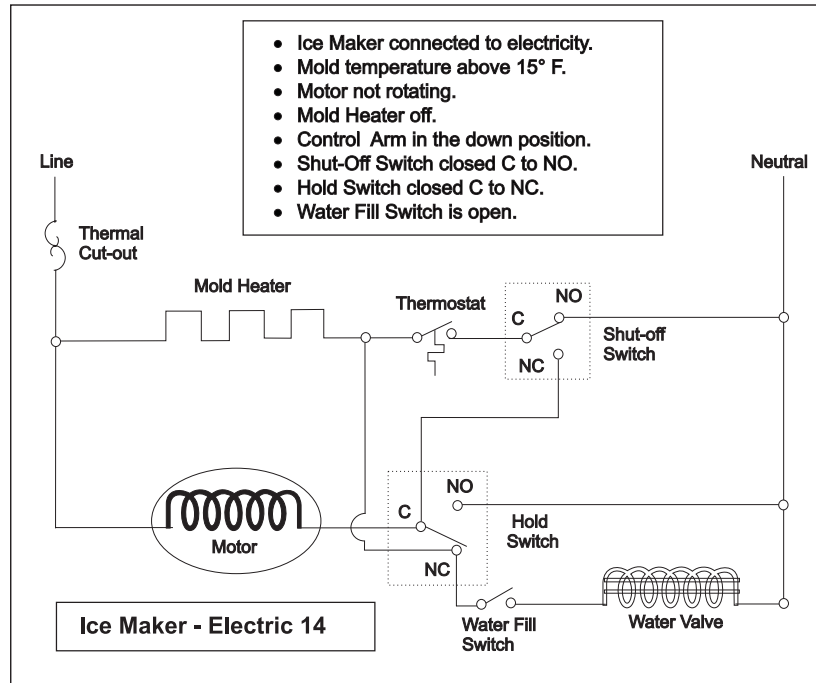

Operating Cycle Illustrations - Mechanical

The following Figures illustrate the mechanical operation of an Ice Maker.

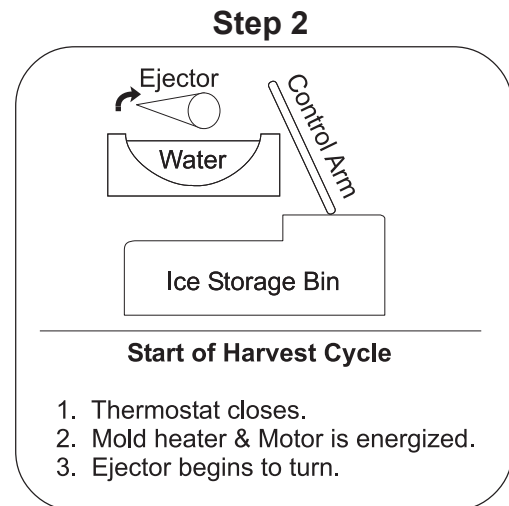
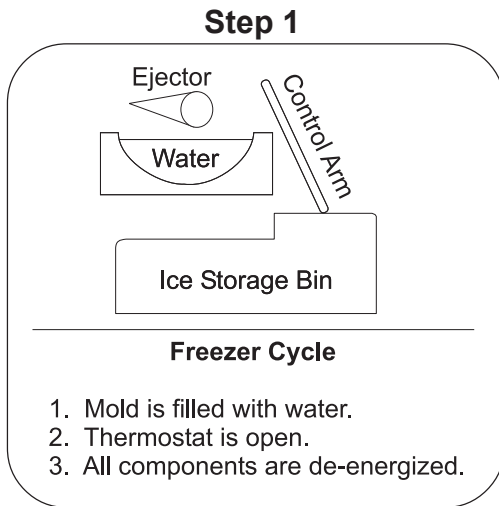

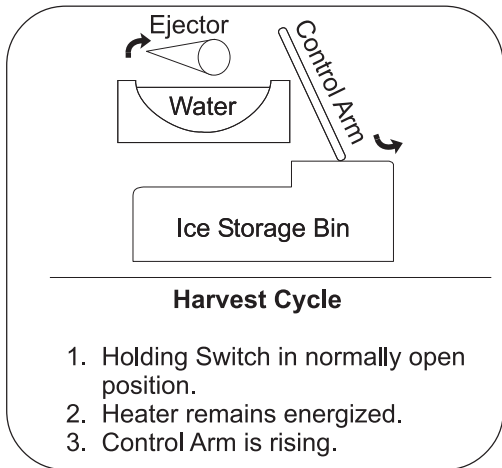

Step 3

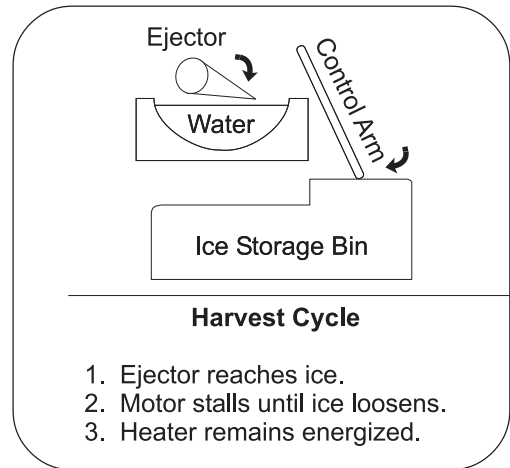

Step 4

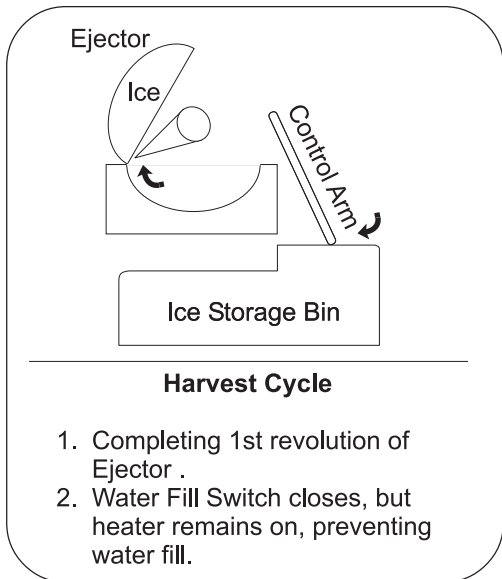

Step 5

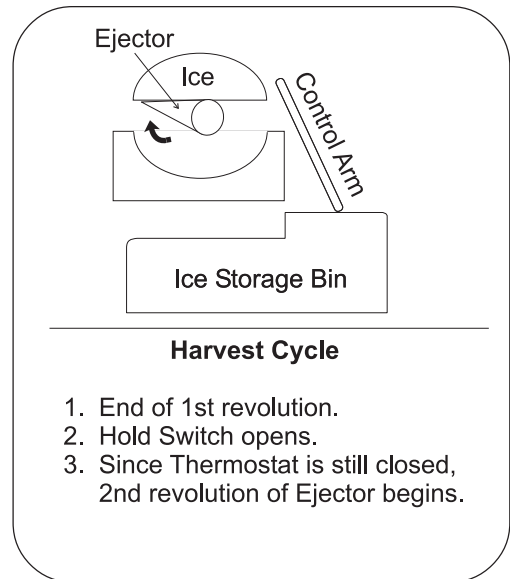

Step 6

Step 7

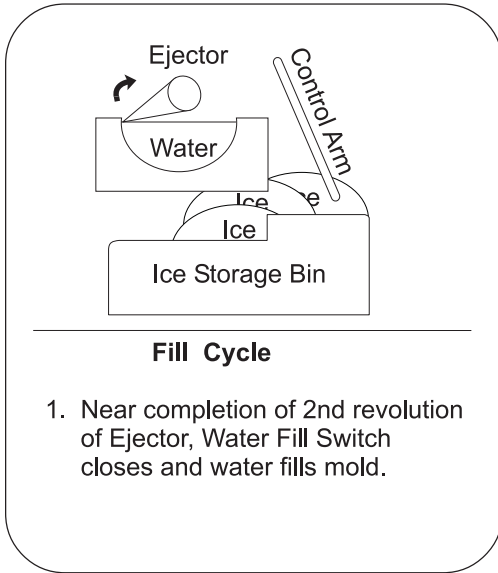

Step 8

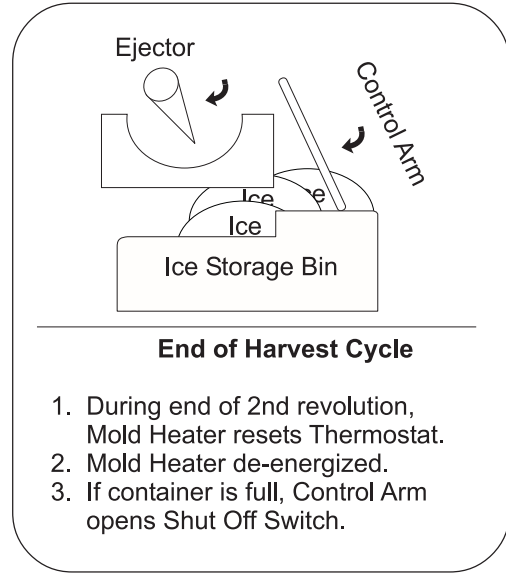

Step 9

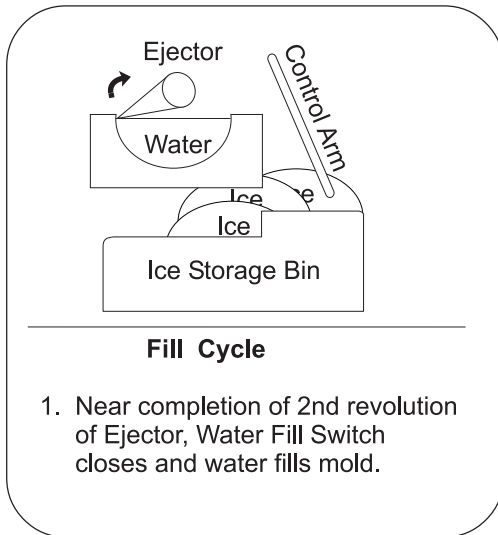

Step 10

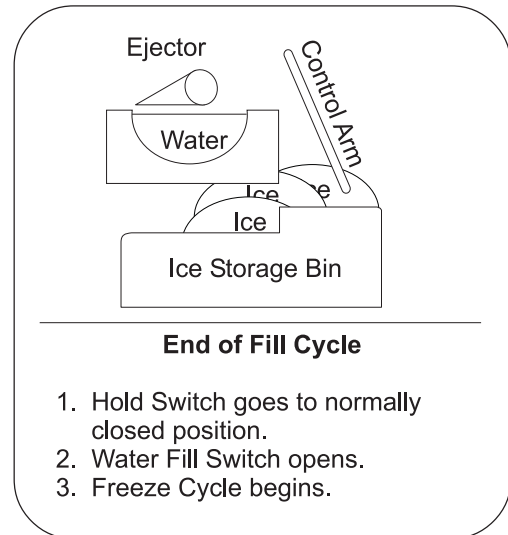

Ice Maker (Exploded View)

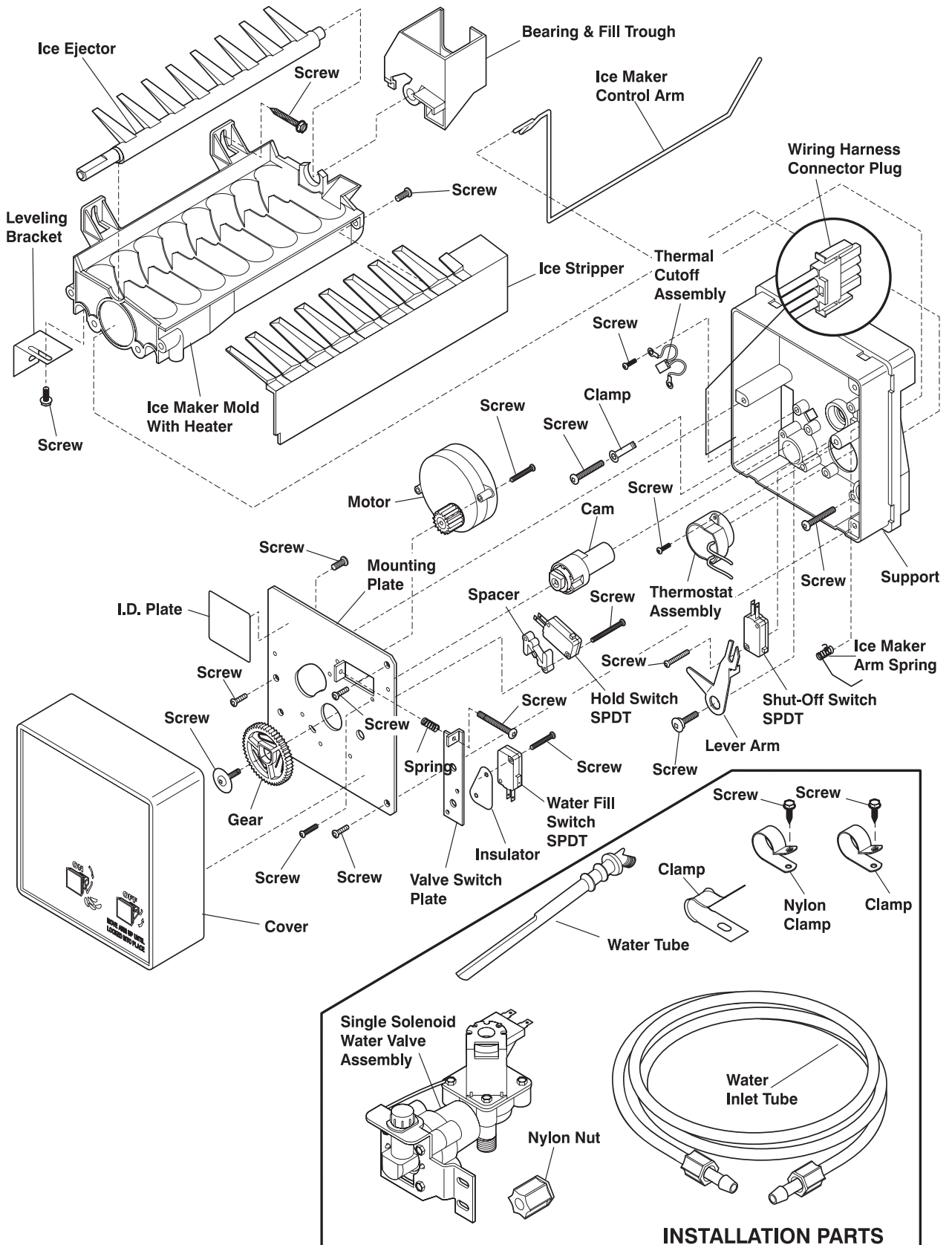

Ice Maker Wiring Diagrams (Enlarged view)

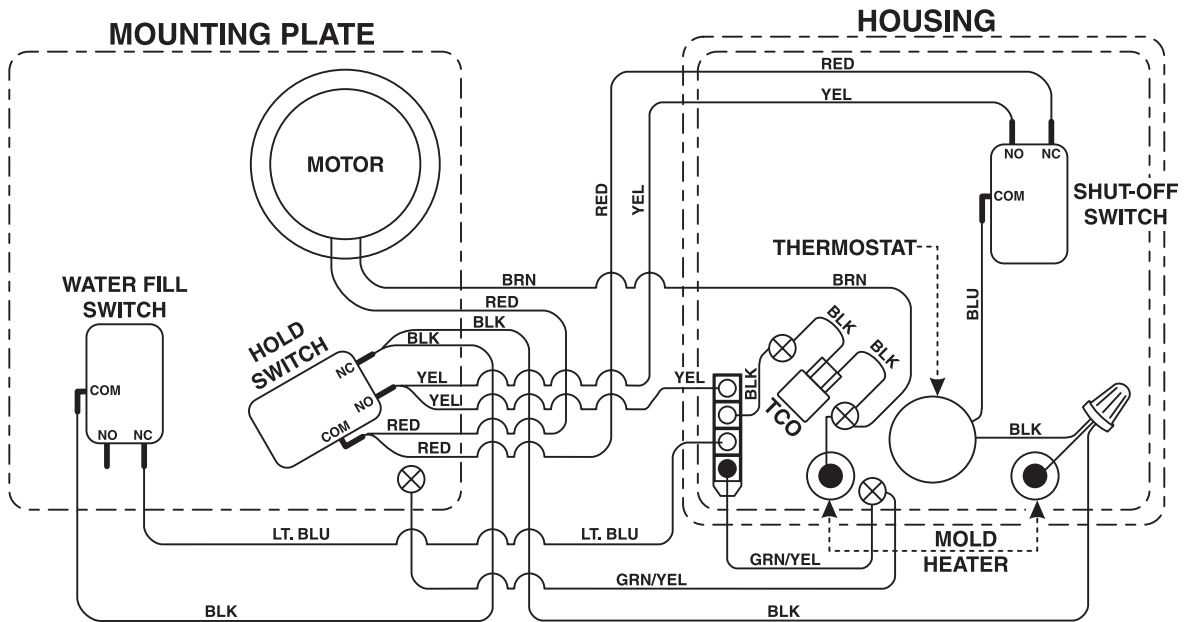
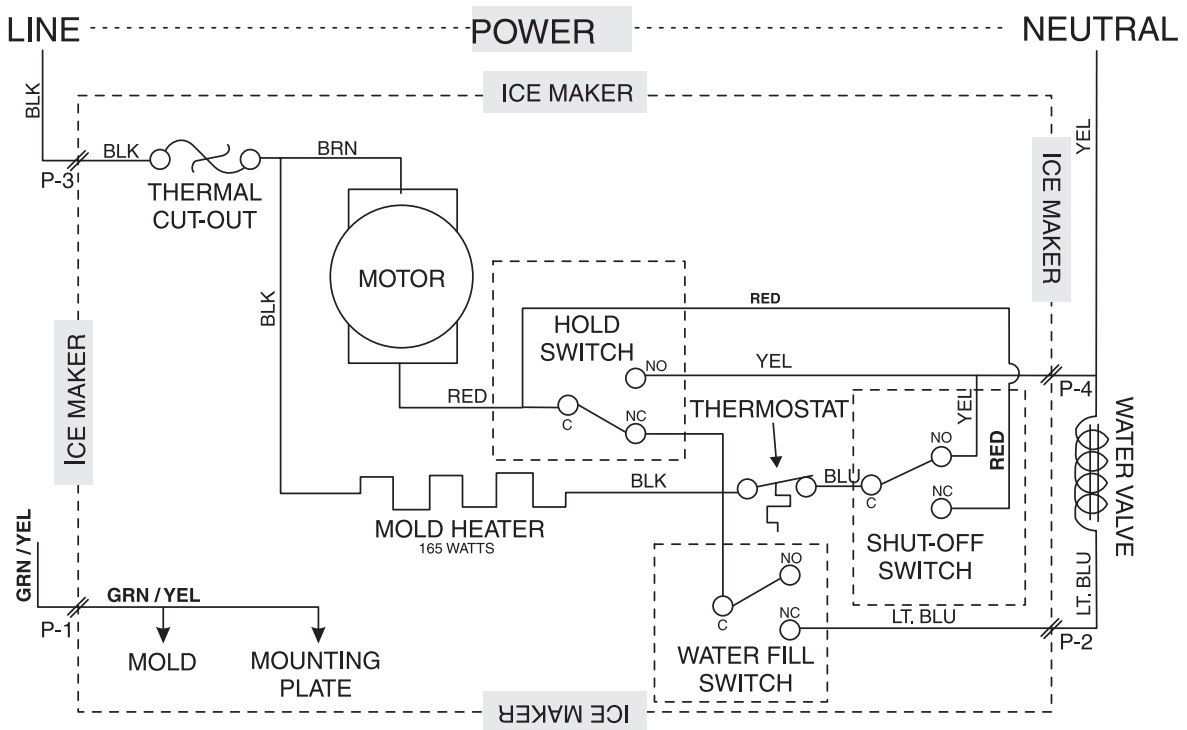

ICE MAKER INSTALLATION INSTRUCTIONS

⚠ WARNING To avoid electric shock, which can cause death or severe personal injury, disconnect the refrigerator from electrical power before connecting a water supply line to the refrigerator.

⚠ CAUTION To Avoid Property Damage:

- Copper tubing is recommended for the water supply line. Water supply tubing made of 1/4" plastic is not recommended since it greatly increases the potential for water leaks. The manufacturer will not be responsible for any damage if plastic tubing is used for the supply line.
- **DO NOT** install water supply tubing in areas where temperatures fall below freezing.
- Connect the ice maker to a drinkable water source that is not tied into a water softening system. Chemicals from the softener may damage the ice maker, causing it to malfunction.

The following items will be required to install the ice maker kit.

- 1/4 inch copper supply line with shut off valve
- 1/4 inch brass compression nut and ferrule
- Freezer shelf (Some models not equipped with shelf). If your model does not have one, contact your dealer to order one.

The copper tubing and shut off valve are available in a kit from your local hardware or plumbing supply store. Coil enough tubing at the back of the unit to allow movement for cleaning.

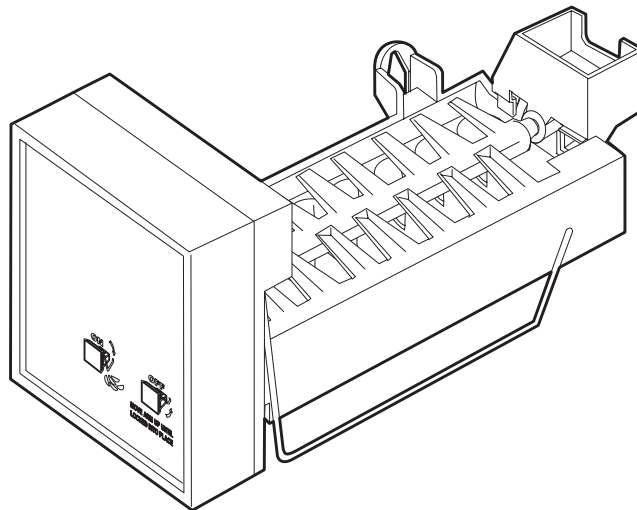

Use This Page to Identify Parts

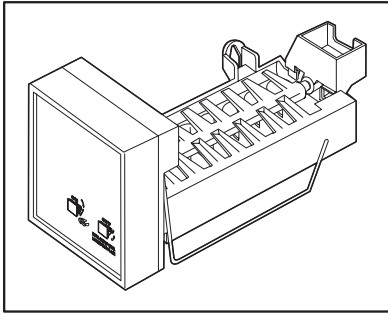

1. Ice Maker

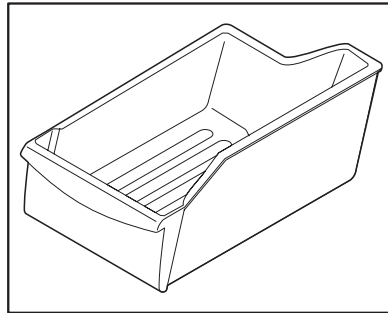

2. Ice Container

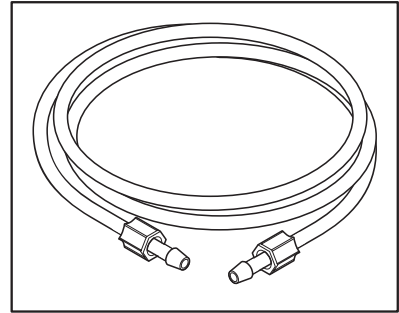

3. Plastic Water Supply Tubing

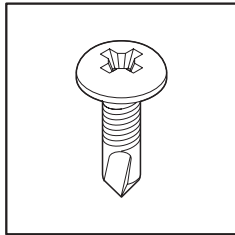

4. Screws - Qty 2

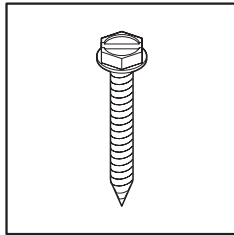

5. Screws - Qty 2

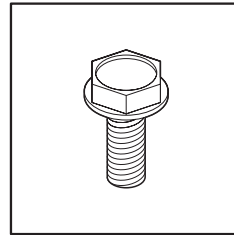

6. Leveling Bracket
Screw - Qty 1

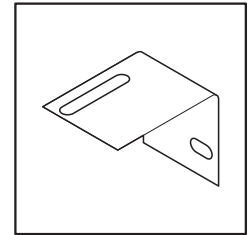

7. Leveling Bracket
Qty 1

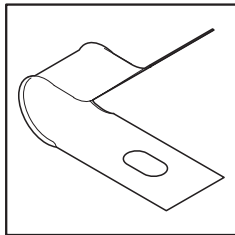

8. Steel Clamp - Qty 1

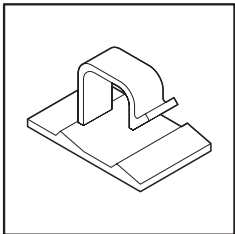

9. Plastic Clamp - Qty 2

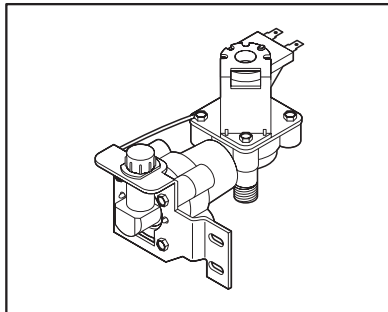

10. Water Valve - Qty 1

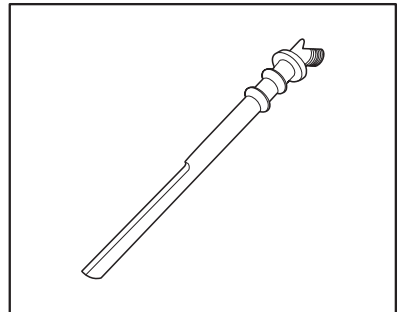

11. Water Inlet Tube - Qty 1

Tools Required:

- Putty Knife
- ¼ inch Socket Wrench or Nut Driver
- Knife
- Pliers
- Needle Nose Pliers
- Adjustable Wrench

1. Unplug refrigerator from wall outlet.
2. Remove ice tray rack from freezer (some models).
3. Remove freezer shelf (some models) by pushing shelf to left until right side of shelf is out of hole. Slowly lift up and pull on shelf to remove.
4. Remove plugs from inside freezer compartment with putty knife.

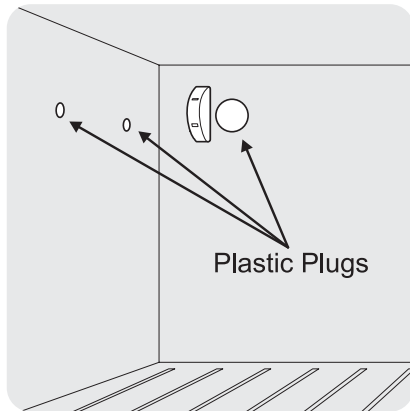

5. If refrigerator has exterior condenser (C), go to rear of refrigerator and locate left condenser mounting bracket screw(s). Remove and save screws. **DO NOT** remove compressor sound baffle (A), if installed. Carefully bend condenser out away from back of refrigerator. If condenser is mounted inside compressor compartment (D), remove screws securing sound baffle to cabinet (B).

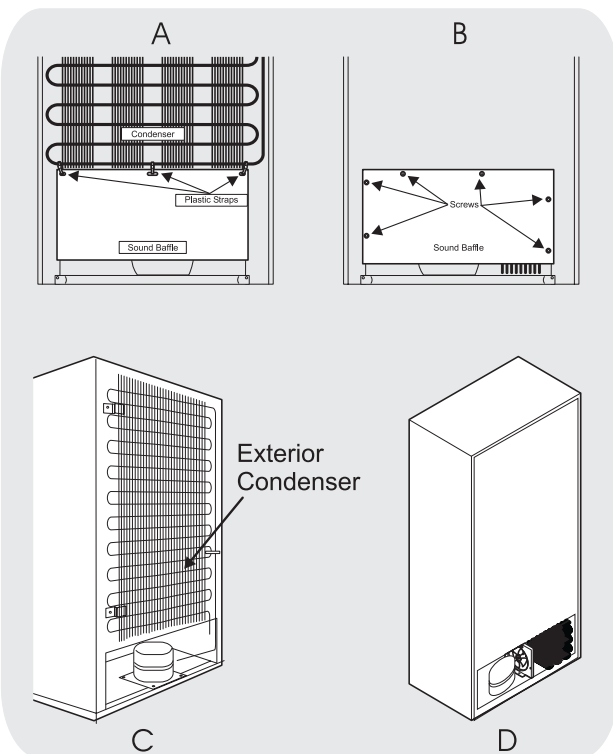

6. Peel off label covering ice maker hole.

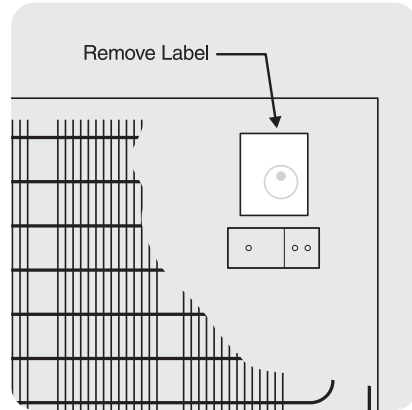

7. With needle nose pliers, remove foam from hole.

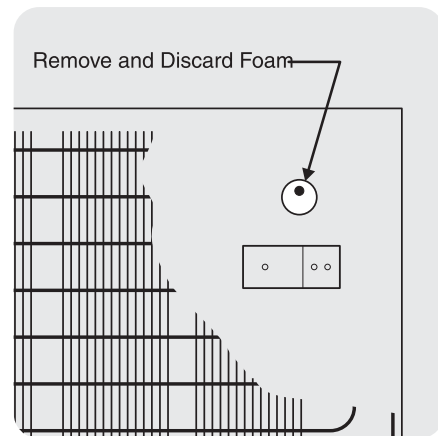

8. Push water inlet tube into small hole on back of refrigerator. Rotate while inserting tube until flat surface of inlet tube is tight against back of refrigerator.

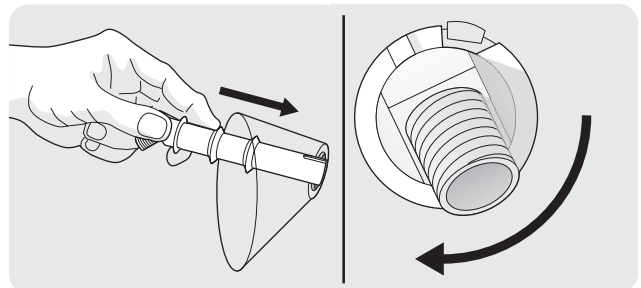

9. Push plastic water supply tubing (3) into water inlet tube (11) as far as it will go and finger tighten nylon compression nut onto threaded end of inlet tube. Tighten another one half turn with a wrench. **DO NOT** over tighten.

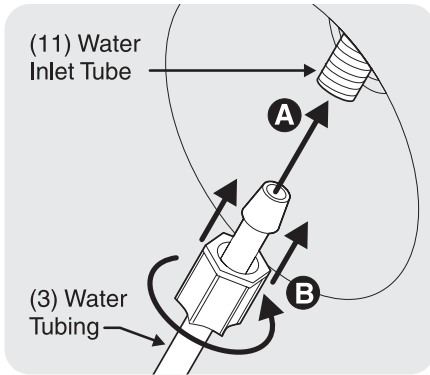

10. Install adjustable leveling bracket (7) on bottom of ice maker with screw (6). **DO NOT** tighten bracket. (Bracket will be tightened later.)

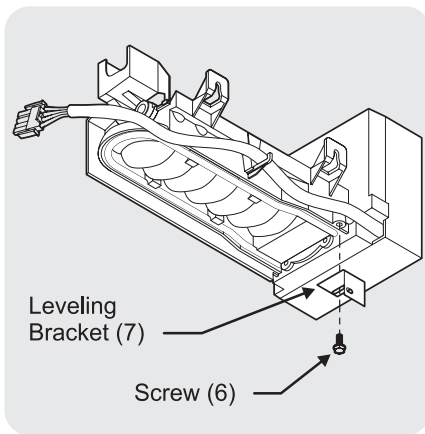

11. Start two, long, ice maker mounting screws (5) into freezer wall. Turn each screw five turns clockwise.

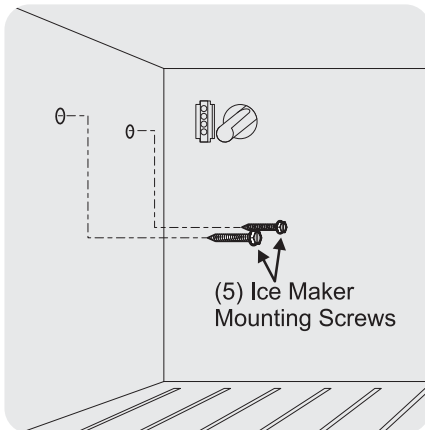

12. With ice maker in one hand, plug ice maker connector into connector mounted on back freezer panel. Make sure connection is tight.

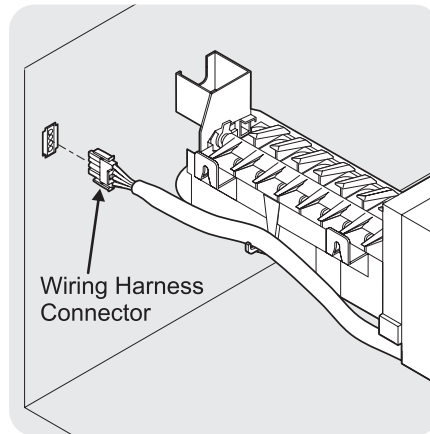

13. Mount ice maker onto two screws (5) you installed in Step 12. Tighten screws. Make sure water inlet tube (11) is sitting inside fill cup.

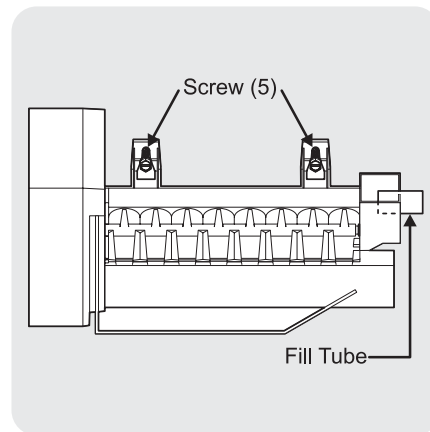

14. Adjust leveling bracket (7) to level ice maker (1). Ice maker is level when gap between freezer wall and ice maker is same at top and bottom. Tighten screw (6) when level.

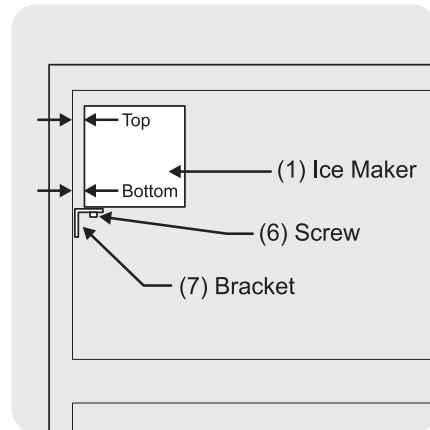

15. Reinstall freezer shelf in lower position. Set ice container (2) on shelf.

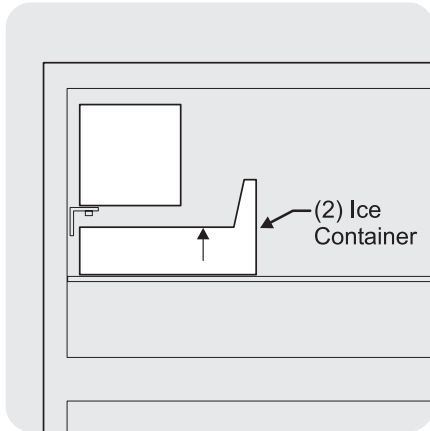

16. Locate factory punched holes at bottom right corner of rear panel. Holes are only drilled through cabinet liner. Align water valve bracket with factory drilled holes. Use a power drill with a Phillips® head bit to drive the two self drilling screws (4) through bracket and into cabinet.

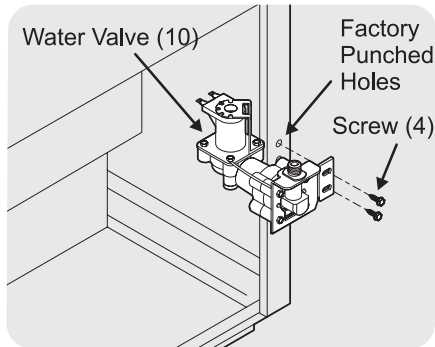

17. Connect wiring harness to water valve. Make sure connection is tight.

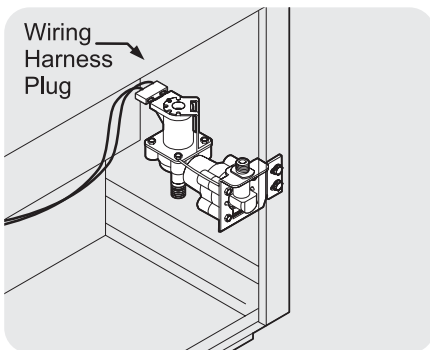

18. Push plastic water supply tubing into bottom of water valve as far as it will go. Finger tighten nylon compression nut onto threaded end of water valve. Tighten another one half turn with wrench. **DO NOT** overtighten.

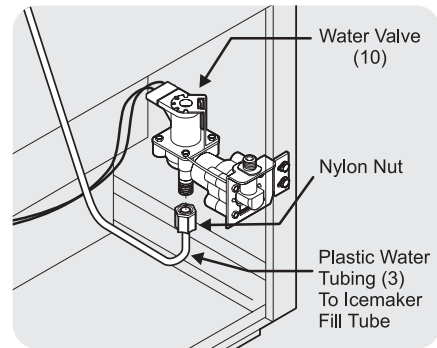

19. Secure plastic water tubing to rear of cabinet with two plastic clamps (9).

NOTE: Clean back of cabinet with a commercial household cleaner, ammonia or alcohol before applying clamps.

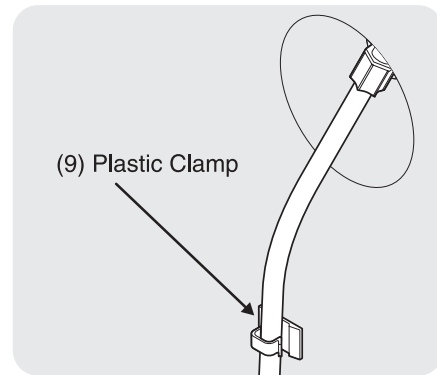

20. On models with exterior condenser, reinstall condenser brackets and tighten down screws.

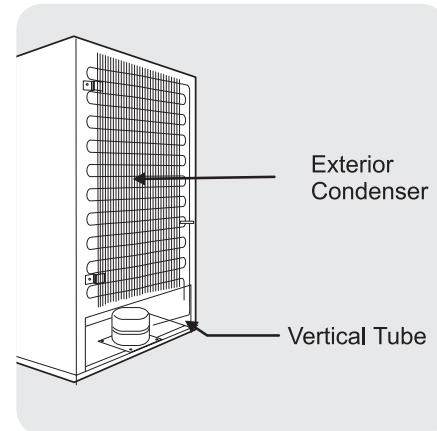

21. On refrigerators with dynamic condensers, remount sound baffle, if installed. See step 5.

