

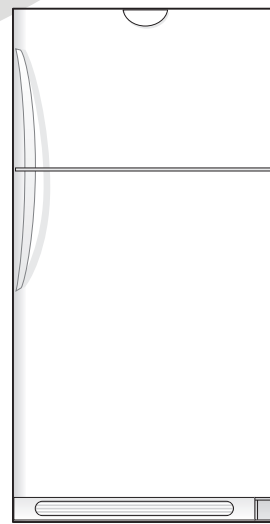

# *Product Information and Technical Guide*

*Side by Side and Top Mount Refrigerators  
January 2004 - March 2004*

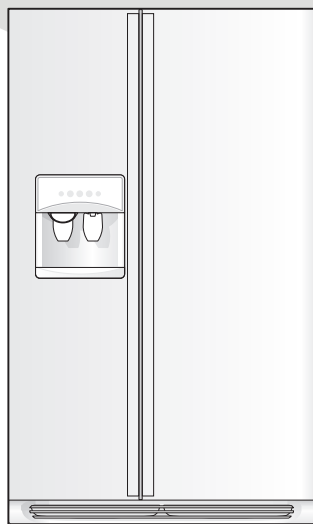

*Frigidaire*

**TAPPAN<sup>®</sup>**

**Gibson<sup>®</sup>**

**W** White-Westinghouse<sup>®</sup>



# TABLE OF CONTENTS

Safe Servicing Practices .....	2
Service Data Sheet, Refrigerant Charge & Energy Efficiency Rating Indexes .....	3 - 7
Troubleshooting Guide .....	8- 12

## Appendix A - Service Data Sheets

240379007 .....	A1 - A2
240379011 .....	A3 - A4
240379012 .....	A5 - A6
240379013 .....	A7 - A8
240379014 .....	A9 - A10
240379015 .....	A11 - A12
241588200 .....	A13 - A14
240389613 .....	A15 - A16
240389615 .....	A17 - A18
240389016 .....	A19 - A20
240389618 .....	A21 - A22
241532603 .....	A23 - 24

# SAFE SERVICING PRACTICES - ALL APPLIANCES

To avoid personal injury and/or property damage, it is important that **Safe Servicing Practices** be observed. The following are some limited examples of safe practices:

1. **DO NOT** attempt a product repair if you have any doubts as to your ability to complete it in a safe and satisfactory manner.
2. Before servicing or moving an appliance:
  - Remove the power cord from the electrical outlet, trip the circuit breaker to the OFF position, or remove the fuse.
  - Turn off the gas supply.
  - Turn off the water supply.
3. Never interfere with the proper operation of any safety device.
4. **USE ONLY REPLACEMENT PARTS CATALOGED FOR THIS APPLIANCE. SUBSTITUTIONS MAY DEFEAT COMPLIANCE WITH SAFETY STANDARDS SET FOR HOME APPLIANCES.**
5. **GROUNDING:** The standard color coding for safety ground wires is **GREEN**, or **GREEN with YELLOW STRIPES**. Ground leads are not to be used as current carrying conductors. It is **EXTREMELY** important that the service technician reestablish all safety grounds prior to completion of service. Failure to do so will create a hazard.
6. Prior to returning the product to service, ensure that:
  - All electrical connections are correct and secure
  - All electrical leads are properly dressed and secured away from sharp edges, high-temperature components, and moving parts
  - All non-insulated electrical terminals, connectors, heaters, etc. are adequately spaced away from all metal parts and panels
  - All safety grounds (both internal and external) are correctly and securely connected
  - All panels are properly and securely reassembled

## ATTENTION!!!

This service manual is intended for use by persons having electrical and mechanical training and a level of knowledge of these subjects generally considered acceptable in the appliance repair trade. Electrolux Home Products, Inc. cannot be responsible, nor assume any liability, for injury or damage of any kind arising from the use of this manual.

<b>Model</b>	<b>Service Data Sheet</b>	<b>Charge</b>	<b>Energy Efficiency Rating</b>	<b>Brand</b>
CRTE151AQ1	240379011	4.5	443	Crosley
CRTE151AW1	240379011	4.5	443	Crosley
CRTE171AQ1	240379011	4.5	460	Crosley
CRTE171AW1	240379011	4.5	460	Crosley
CRTE183AQ0	240379011	4.25	479	Crosley
CRTE183AW0	240379011	4.25	479	Crosley
CRTE187AK0	240379013	4.25	479	Crosley
CRTE187AS0	240379013	4.25	479	Crosley
E23CS75DSS1	241532603	5.75	687	Electrolux
FRS23BH6CS2	240389616	5	583	Frigidaire
FRS23F4CB5	240389616	5	686	Frigidaire
FRS23F4CQ4	240389616	5	686	Frigidaire
FRS23F4CQ5	240389616	5	686	Frigidaire
FRS23F4CW4	240389616	5	686	Frigidaire
FRS23F4CW5	240389616	5	686	Frigidaire
FRS23FCDB0	240389616	5	686	Frigidaire
FRS23FCDQ0	240389616	5	686	Frigidaire
FRS23FCDW0	240389616	5	686	Frigidaire
FRS23H5DSB0	240389618	5	583	Frigidaire
FRS23H7CB2	240389615	5	583	Frigidaire
FRS23H7CQ2	240389615	5	583	Frigidaire
FRS23H7CW2	240389615	5	583	Frigidaire
FRS23KF6CB2	240389615	5	583	Frigidaire
FRS23KF6CQ2	240389615	5	583	Frigidaire
FRS23LH5DS0	240389616	5	583	Frigidaire
FRS23LH5DW0	240389616	5	583	Frigidaire
FRS23R4CB4	240389615	5	686	Frigidaire
FRS23R4CB5	240389616	5	686	Frigidaire
FRS23R4CQ4	240389615	5	686	Frigidaire
FRS23R4CQ5	240389616	5	686	Frigidaire
FRS23R4CW4	240389615	5	686	Frigidaire
FRS23R4CW5	240389616	5	686	Frigidaire
FRS23W3AQB	240389615	5	686	Frigidaire
FRS23W3AQC	240389616	5	686	Frigidaire
FRS23W3AWB	240389615	5	686	Frigidaire
FRS23W3AWC	240389616	5	686	Frigidaire
FRS26BH6CW4	240389615	5.25	618	Frigidaire
FRS26DR7DS0	240389618	5.25	618	Frigidaire
FRS26F4CB2	240389616	5.25	727	Frigidaire
FRS26F4CB3	240389616	5.25	727	Frigidaire
FRS26F4CQ2	240389616	5.25	727	Frigidaire
FRS26F4CQ3	240389616	5.25	727	Frigidaire
FRS26F4CW2	240389616	5.25	727	Frigidaire
FRS26F4CW3	240389616	5.25	727	Frigidaire
FRS26FCDB0	240389616	5.25	727	Frigidaire
FRS26FCDQ0	240389616	5.25	727	Frigidaire
FRS26FCDW0	240389616	5.25	727	Frigidaire
FRS26H7CQ4	240389615	5.25	618	Frigidaire
FRS26H7CW4	240389615	5.25	618	Frigidaire
FRS26HF6BB6	240389615	5.25	618	Frigidaire
FRS26HF6BQ6	240389615	5.25	618	Frigidaire
FRS26HR4DB0	240389616	5.25	618	Frigidaire
FRS26HR4DQ0	240389616	5.25	618	Frigidaire
FRS26HR4DW0	240389616	5.25	618	Frigidaire
FRS26LF7DS0	240389616	5.25	618	Frigidaire
FRS26LF8CB1	240389615	5.25	618	Frigidaire

<b>Model</b>	<b>Service Data Sheet</b>	<b>Charge</b>	<b>Energy Efficiency Rating</b>	<b>Brand</b>
FRS26LF8CQ1	240389615	5.25	618	Frigidaire
FRS26LH5DB0	240389616	5.25	618	Frigidaire
FRS26LH5DQ0	240389616	5.25	618	Frigidaire
FRS26LH5DS0	240389616	5.25	618	Frigidaire
FRS26LH5DW0	240389616	5.25	618	Frigidaire
FRS26R2AQ7	240389616	5.25	727	Frigidaire
FRS26R2AQ8	240389616	5.25	727	Frigidaire
FRS26R2AW7	240389616	5.25	727	Frigidaire
FRS26R2AW8	240389616	5.25	727	Frigidaire
FRS26R4CB2	240389616	5.25	727	Frigidaire
FRS26R4CB3	240389616	5.25	727	Frigidaire
FRS26R4CQ3	240389616	5.25	727	Frigidaire
FRS26R4CW2	240389616	5.25	727	Frigidaire
FRS26R4CW3	240389616	5.25	727	Frigidaire
FRS26RBCW2	240389616	5.25	727	Frigidaire
FRS26RBCW3	240389616	5.25	727	Frigidaire
FRS26RLECS1	240389616	5.25	727	Frigidaire
FRS26RLECS2	240389616	5.25	727	Frigidaire
FRS26W2AQ7	240389613	5.25	727	Frigidaire
FRS26W2AW8	240389616	5.25	727	Frigidaire
FRS26W2AW9	240389616	5.25	727	Frigidaire
FRT14A2AW4	240379015	4.5	440	Frigidaire
FRT14A2AZ4	240379015	4.5	440	Frigidaire
FRT15A2DW0	240379015	4.5	443	Frigidaire
FRT15A2DZ0	240379015	4.5	443	Frigidaire
FRT15B1BW2	240379015	4.5	443	Frigidaire
FRT15B3AQ5	240379015	4.5	443	Frigidaire
FRT15B3AT5	240379015	4.5	443	Frigidaire
FRT15B3AW5	240379015	4.5	443	Frigidaire
FRT15B3AZ5	240379015	4.5	443	Frigidaire
FRT15G4BQ3	240379015	4.5	443	Frigidaire
FRT15G4BW3	240379015	4.5	443	Frigidaire
FRT15HB3DQ0	240379015	4.25	376	Frigidaire
FRT15HB3DW0	240379015	4.25	376	Frigidaire
FRT15HB3DZ0	240379015	4.25	376	Frigidaire
FRT17A2AQ4	240379011	4.5	460	Frigidaire
FRT17A2AW4	240379011	4.5	460	Frigidaire
FRT17A2AZ4	240379011	4.5	460	Frigidaire
FRT17B3AQ5	240379011	4.5	460	Frigidaire
FRT17B3AT5	240379011	4.5	460	Frigidaire
FRT17B3AW5	240379011	4.5	460	Frigidaire
FRT17B3AZ5	240379011	4.5	460	Frigidaire
FRT17G4BD3	240379011	4.5	460	Frigidaire
FRT17G4BQ3	240379011	4.5	460	Frigidaire
FRT17G4BW3	240379011	4.5	460	Frigidaire
FRT18B1BW4	240379015	4.5	479	Frigidaire
FRT18B4AQA	240379015	4.5	479	Frigidaire
FRT18B4AWA	240379015	4.5	479	Frigidaire
FRT18B4AZA	240379015	4.5	479	Frigidaire
FRT18B5ABB	240379014	4.25	479	Frigidaire
FRT18B5AQB	240379014	4.25	479	Frigidaire
FRT18B5AWB	240379014	4.25	479	Frigidaire
FRT18B6CB7	240379014	4.25	479	Frigidaire
FRT18G4AQC	240379011	4.5	479	Frigidaire
FRT18G4AWC	240379011	4.5	479	Frigidaire
FRT18G7CW4	240379015	4.5	479	Frigidaire

<b>Model</b>	<b>Service Data Sheet</b>	<b>Charge</b>	<b>Energy Efficiency Rating</b>	<b>Brand</b>
FRT18H6CB5	240379014	4.25	407	Frigidaire
FRT18H6CQ5	240379014	4.25	407	Frigidaire
FRT18H6CSB4	240379015	4.25	407	Frigidaire
FRT18H6CSK4	240379015	4.25	407	Frigidaire
FRT18H6CW5	240379014	4.25	407	Frigidaire
FRT18HB5DW0	240379015	4.25	407	Frigidaire
FRT18HS6AB5	240379014	4.25	407	Frigidaire
FRT18HS6DB1	240379014	4.25	407	Frigidaire
FRT18HS6DQ0	240379015	4.25	407	Frigidaire
FRT18HS6DW0	240379015	4.25	407	Frigidaire
FRT18IB4AQA	240379015	4.5	479	Frigidaire
FRT18IB4AWA	240379015	4.5	479	Frigidaire
FRT18IB4AZ8	240379011	4.5	479	Frigidaire
FRT18IB4AZA	240379015	4.5	479	Frigidaire
FRT18IG4AQA	240379015	4.5	479	Frigidaire
FRT18IG4ATA	240379015	4.5	479	Frigidaire
FRT18IG4AWA	240379015	4.5	479	Frigidaire
FRT18IG4AZA	240379015	4.5	479	Frigidaire
FRT18IL6DQ0	240379015	4.25	479	Frigidaire
FRT18IL6DS0	240379015	4.25	479	Frigidaire
FRT18IL6DW0	240379015	4.25	479	Frigidaire
FRT18IS6CB1	240379007	4.25	479	Frigidaire
FRT18KB2CW4	240379015	4.5	479	Frigidaire
FRT18KG3CW4	240379015	4.5	479	Frigidaire
FRT18KG4CW4	240379015	4.5	479	Frigidaire
FRT18LN5BQ6	240379015	4.5	479	Frigidaire
FRT18LN5BW6	240379015	4.5	479	Frigidaire
FRT21BH8CB2	240379014	4.25	432	Frigidaire
FRT21BH8CS2	240379014	4.25	432	Frigidaire
FRT21BH8CW2	240379014	4.25	432	Frigidaire
FRT21BSDSB0	241588200	4.5	432	Frigidaire
FRT21C5AQ9	240379014	4.5	509	Frigidaire
FRT21C5AW9	240379014	4.5	509	Frigidaire
FRT21FG3CQ3	240379014	4.25	509	Frigidaire
FRT21FG3CW3	240379014	4.25	509	Frigidaire
FRT21FG4CQ3	240379014	4.25	509	Frigidaire
FRT21FG4CW3	240379014	4.25	509	Frigidaire
FRT21G3CW2	240379012	4.25	509	Frigidaire
FRT21G3CW3	240379014	4.25	509	Frigidaire
FRT21G4BQ7	240379014	4.25	509	Frigidaire
FRT21G4BW7	240379014	4.25	509	Frigidaire
FRT21H7ASB5	240379014	4.25	432	Frigidaire
FRT21H7ASK4	240379014	4.25	432	Frigidaire
FRT21H8CB2	240379014	4.25	432	Frigidaire
FRT21H8CQ2	240379014	4.25	432	Frigidaire
FRT21H8CSB2	240379014	4.5	432	Frigidaire
FRT21H8CSK2	240379014	4.5	432	Frigidaire
FRT21H8CW2	240379014	4.25	432	Frigidaire
FRT21HS6AW6	240379014	4.25	432	Frigidaire
FRT21HS6DB0	240379014	4.5	432	Frigidaire
FRT21HS6DQ0	240379014	4.5	432	Frigidaire
FRT21HS6DW0	240379014	4.5	432	Frigidaire
FRT21IL5DQ0	240379014	4.25	509	Frigidaire
FRT21IL5DW0	240379014	4.25	509	Frigidaire
FRT21KG3CW3	240379014	4.25	509	Frigidaire
FRT21KG4CW3	240379014	4.25	509	Frigidaire

<b>Model</b>	<b>Service Data Sheet</b>	<b>Charge</b>	<b>Energy Efficiency Rating</b>	<b>Brand</b>
FRT21KS6CQ3	240379014	4.5	509	Frigidaire
FRT21LR7AB9	240379014	4.25	432	Frigidaire
FRT21LR7AQ9	240379014	4.25	432	Frigidaire
FRT21LR7AW9	240379014	4.25	432	Frigidaire
FRT21LR8DS0	240379014	4.25	458	Frigidaire
FRT21P5ABA	240379014	4.25	509	Frigidaire
FRT21P5AQA	240379014	4.25	509	Frigidaire
FRT21P5AWA	240379014	4.25	509	Frigidaire
FRT21P6CQ3	240379014	4.25	509	Frigidaire
FRT21P6CSB3	240379014	4.25	509	Frigidaire
FRT21P6CSK3	240379014	4.25	509	Frigidaire
FRT21P6CW3	240379014	4.25	509	Frigidaire
FRT21S6AB8	240379014	4.25	509	Frigidaire
FRT21S6AW8	240379014	4.25	509	Frigidaire
GLHS237ZCW2	240389016	5	583	Frigidaire
GLHS269ZCB4	240389015	5.25	618	Frigidaire
GLRS237ZCB4	240389015	5	686	Frigidaire
GLRS237ZCB5	240389016	5	686	Frigidaire
GLRS237ZCQ4	240389015	5	686	Frigidaire
GLRS237ZCQ5	240389016	5	686	Frigidaire
GLRS237ZCW4	240389015	5	686	Frigidaire
GLRS237ZCW5	240389016	5	686	Frigidaire
GLRS267ZCB2	240389616	5.25	727	Frigidaire
GLRS267ZCB3	240389616	5.25	727	Frigidaire
GLRS267ZCQ2	240389616	5.25	727	Frigidaire
GLRS267ZCQ3	240389616	5.25	727	Frigidaire
GLRS267ZCW2	240389616	5.25	727	Frigidaire
GLRS267ZCW3	240389616	5.25	727	Frigidaire
GLRT183TDB1	240379013	4.25	479	Frigidaire
GLRT183TDB3	240379014	4.25	479	Frigidaire
GLRT183TDQ0	240379015	4.25	479	Frigidaire
GLRT183TDW0	240379015	4.25	479	Frigidaire
GLRT184TCB7	240379014	4.25	479	Frigidaire
GLRT185TDB1	240379012	4.25	479	Frigidaire
GLRT185TDB3	240379014	4.25	479	Frigidaire
GLRT185TDK0	240379015	4.25	479	Frigidaire
GLRT185TDQ0	240379015	4.25	479	Frigidaire
GLRT185TDS0	240379015	4.25	479	Frigidaire
GLRT185TDW0	240379015	4.25	479	Frigidaire
GLRT212IDB0	240379012	4.25	509	Frigidaire
GLRT212IDB1	240379014	4.25	509	Frigidaire
GLRT212IDQ0	240379012	4.25	509	Frigidaire
GLRT212IDQ1	240379014	4.25	509	Frigidaire
GLRT212IDW0	240379012	4.25	509	Frigidaire
GLRT212IDW1	240379014	4.25	509	Frigidaire
GLRT214TCB3	240379014	4.25	509	Frigidaire
GLRT214TCQ3	240379014	4.25	509	Frigidaire
GLRT214TCW3	240379014	4.25	509	Frigidaire
GRS23R4CQ3	240389613	5	686	Frigidaire
GS18HTZCQ2	240379011	4.25	431	Frigidaire
GS18HTZCW2	240379011	4.25	431	Frigidaire
GS18HTZDB1	240379014	4.25	407	Frigidaire
GS18HTZDSB0	240379015	4.25	407	Frigidaire
GS18HTZDSK0	240379015	4.25	407	Frigidaire
GS18HTZDW0	240379015	4.25	407	Frigidaire
GS23HSZCC3	240389615	5	583	Frigidaire



<b>Model</b>	<b>Service Data Sheet</b>	<b>Charge</b>	<b>Energy Efficiency Rating</b>	<b>Brand</b>
GS23HSZCQ2	240389615	5	583	Frigidaire
GS26HSZCC5	240389616	5	583	Frigidaire
GS26HSZCQ4	240389616	5	583	Frigidaire
PLHT189CSB4	240379015	4.25	407	Frigidaire
PLHT189CSK4	240379015	4.25	407	Frigidaire
PLHT219TCB4	240379014	4.25	432	Frigidaire
PLHT219TCK4	240379014	4.25	432	Frigidaire
FSC23F7DB0	241532603	5.75	687	Frigidaire-CD
PHSC239DSB0	241532603	6	584	Frigidaire-CD
GRT15B3BW3	240379011	4.5	443	Gibson
GRT17B3BQ3	240379011	4.5	460	Gibson
GRT17B3BW3	240379011	4.5	460	Gibson
GRT17G4BQ3	240379011	4.5	460	Gibson
GRT17G4BW3	240379011	4.5	460	Gibson
GRT21G3CW3	240379014	4.5	509	Gibson
GRT21S6CW3	240379014	4.5	509	Gibson
WRS23MF5ASA	240389616	5	686	W / W
WRS23MW3AQA	240389616	5	686	W / W
WRS23MW3AW9	240389615	5	686	W / W
WRS23MW3AWA	240389616	5	686	W / W
WRS23W0AWA	240389615	5	686	W / W
WRS23W0AWB	240389616	5	686	W / W
WRT15A0AW4	240379015	4.5	443	W / W
WRT15MB3AW4	240379015	4.25	443	W / W
WRT15MG4BQ1	240379011	4.25	443	W / W
WRT17MB3AW4	240379015	4.25	460	W / W
WRT17MG4BQ1	240379011	4.25	460	W / W
WRT18A0AWA	240379015	4.5	479	W / W
WRT21MG3AQ6	240379014	4.25	509	W / W
WRT21MG3AW6	240379014	4.25	509	W / W
WRT21MP5AQ7	240379014	4.25	509	W / W
WRT21MP5AW7	240379014	4.25	509	W / W
WRT21MR7AS6	240379014	4.25	509	W / W
WRT21S4AW6	240379014	4.25	509	W / W

# TROUBLESHOOTING GUIDE

PROBLEM	CAUSE	SOLUTION
Compressor will not run.	No voltage at wall receptacle.	Check circuit breaker, fuse or GFCI (Ground Fault Circuit Interruptor - <b>It is not recommended to connect your refrigerator to a GFCI.</b> )
	Service cord defective or unplugged at wall receptacle.	Check service cord.
	Low voltage causing compressor to cycle on overload.	Voltage fluctuation should not exceed $\pm 10\%$ of 115 vac (104-127)
	Control thermostat knob in OFF position.	Turn control thermostat knob to ON position.
	Inoperative control thermostat.	Replace control thermostat
	Compressor stuck.	Replace compressor.
	Compressor windings open.	Replace compressor.
	Defrost timer stuck in defrost mode.	Replace defrost timer. (if equipped)
	ADC (Adaptive Defrost Control) not turning on compressor after defrost.	Replace ADC.
	Compressor overload stuck open.	Replace compressor overload. (if equipped – compressor starter relay & overload may be plugged into each other)
	Relay lead loose.	Repair or replace lead.
	Relay loose or inoperative.	Repair or replace relay. (if equipped)
	Service cord pulled out of harness.	Repair connection.
	Faulty cabinet wiring.	Repair wiring.
Compressor runs but does not cool.	System out of refrigerant.	Check for leaks. *
	Compressor not pumping.	Replace compressor. *
	Restricted filter drier.	Replace filter drier. *
	Restricted capillary tube.	Replace heat exchanger and evaporator assembly.
	Moisture in system.	See NOTE. *

**\* NOTE:**

- Repair or replace component that is leaking.
- Replace the compressor if the system is contaminated.
- Blow out remaining part of system with dry Nitrogen.
- Pump down and recharge per listing on product serial label.
- Always replace filter drier when repairing sealed system.

<b>PROBLEM</b>	<b>CAUSE</b>	<b>SOLUTION</b>
Compressor short cycles.	Erratic control thermostat.	Replace control thermostat.
	Faulty relay.	Replace relay or starter.
	Restricted air flow over condenser.	Ensure air flow is unobstructed over condenser.
	Low voltage ... fluctuation exceeds $\pm$ 10% of 115 vac (104-127).	Call qualified electrician.
	Compressor draws excessive watts.	Replace compressor.
	Inoperative condenser fan motor.	Replace condenser fan motor.
Compressor runs too much.	Control thermostat is erratic or not properly set.	Replace control thermostat or reset to normal position.
	Refrigerator exposed to high heat. (110° or higher)	Move refrigerator to cooler location.
	High room temperature. (110° F or higher)	Advise customer not to install refrigerator where temperature will rise above 110°F because compressor will not maintain proper temperatures.
	Low pumping capacity compressor.	Replace compressor.
	Door gaskets not sealing.	Adjust doors or replace door gaskets.
	System undercharged.	Check for leaks. *
	System overcharged.	Charge per listing on product serial plate. *
	Interior light stays on.	Check door switch and door adjustment.
	Contaminants in system.	Flush out system. Replace filter drier, evacuate, and recharge. *
	Capillary tube kinked or partially restricted.	Replace heat exchanger and evaporator assembly. *
	Filter drier partially restricted.	Replace filter drier. *
	Refrigerator and/or freezer compartment overloaded ... poor air circulation	Advise customer.
	Restricted air flow over condenser.	Ensure air flow is unobstructed over condenser.
	Condenser fan motor is inoperative. (Forced air condenser models only)	Replace condenser fan motor.
Noisy.	Tubing vibrates.	Adjust tubing.
	Internal compressor noise.	Replace compressor.
	Loose parts.	Check shelving.
	Compressor operating at high head pressure due to restricted air flow over condenser.	Ensure air flow is unobstructed over condenser.

\* See NOTE at bottom of page 8)

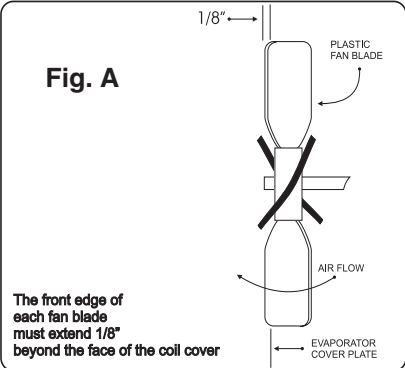
PROBLEM	CAUSE	SOLUTION
<p>Freezer compartment too warm.</p> <div data-bbox="168 302 570 667"> <p><b>Fig. A</b></p>  <p>The front edge of each fan blade must extend 1/8" beyond the face of the coil cover</p> </div>	Inoperative evaporator fan motor.	Check wiring and evaporator fan motor. (Check ADC on Side-by-Sides.)
	Improperly positioned fan blade.	Position fan blade properly. See Figure A.
	Evaporator frosted up.	Check defrost system, door adjustments, and door gaskets.
	Inoperative condenser fan motor. (Forced air condenser models only)	Replace condenser fan motor.
	Restricted air flow over condenser – On static condensers, be sure you have 1" between condenser and wall, and 3" over top, or 1 side of condenser is clear.	Clean condenser. (Dynamic models only.)
	Freezer compartment overloaded – poor air circulation.	Advise customer.
	Low room temperature.(55°)	Advise customer not to install refrigerator where temperature will drop below 60°F. Compressor will not maintain proper temperatures.
	Freezer or refrigerator compartment doors left open.	Advise customer.
	Control thermostat out of calibration.	Replace control thermostat.
	Door gaskets not sealing.	Adjust doors or replace door gaskets.
	Control thermostat capillary tube improperly positioned.	Reposition temperature sensing element.
	Shortage of refrigerant.	Check for leaks. *
	Restricted filter drier or capillary tube.	Check for leaks and burnt compressor windings. *
Evaporator fan motor covered in ice.	Check seal around ice maker fill spout. Check seal between evaporator cover and liner. (Side-by-sides only)	
Freezer compartment too cold.	Inoperative cold control. (Top mount-No Frost or Side-by-Side freezer cold control)	Replace cold control.
	Freezer compartment inlet air duct is loose or restricted. Door is loose.	Re-install air duct or remove obstruction from inlet air duct. Adjust door.
	Food compartment air return duct blocked (Top Mount only)	If foam block is frozen, replace block. If duct is blocked, remove obstruction.
	Diffuser (foam block) in top of food compartment is broken. (Foam block located in control housing.)	Replace diffuser. (Top Mount only) Freezer compartment cold control installed incorrectly. (Side-by-Sides only)

\* See NOTE at bottom of page 8

<b>PROBLEM</b>	<b>CAUSE</b>	<b>SOLUTION</b>
Refrigerator compartment too warm.	Inoperative evaporator fan motor.	Check wiring and evaporator fan motor. (Check ADC on Side-by-Sides.)
	Improperly positioned fan blade.	Position fan blade properly. See page 10, Figure A.
	Evaporated frosted up.	Check defrost system, door adjustments, and door gaskets.
	Refrigerator compartment overloaded – poor air circulation.	Advise customer.
	Low room temperature. (55°)	Advise customer not to install refrigerator where temperature will drop below 60°F. Compressor will not maintain proper temperatures.
	Freezer or refrigerator compartment doors left open.	Advise customer.
	Damper control out of calibration or not opening.	Replace damper control.
	Shortage of refrigerant.	Check for leaks. *
	Restricted filter drier or capillary tube.	Check for leaks and burnt compressor windings. *
	Refrigerator compartment inlet air duct loose or restricted. Door is loose.	Re-install air duct or remove obstruction from air duct. Adjust door.
	Freezer compartment return air duct restricted.	Remove obstruction from return air duct.
	Control thermostat knob set at too warm a position.	Set control knob to a colder position.
	Inoperative or erratic refrigerator/freezer compartment door switch.	Replace door switch.
	Freezer compartment inlet air duct is loose or restricted. Door is loose.	Re-install air duct or remove obstruction from inlet air duct. Adjust door.
Food compartment air return duct blocked (Top Mount only)	If foam block is frozen, replace block. If duct is blocked, remove obstruction.	
Refrigerator compartment too cold.	Inoperative cold control.	Replace cold control.
	Refrigerator compartment inlet air duct loose or restricted. Door is loose.	Re-install air duct or remove obstruction from air duct. Adjust door.
	Diffuser (foam block) in top of food compartment is broken. (Foam blocked located in control housing.)	Replace diffuser. (Top Mounts only)

\* See NOTE at bottom of page 8.

<b>PROBLEM</b>	<b>CAUSE</b>	<b>SOLUTION</b>
Refrigerator compartment too cold. (Continued)	Inoperative cold control.	Replace cold control.
	Refrigerator compartment inlet air duct loose or restricted. Door is loose.	Re-install air duct or remove obstruction from air duct. Adjust door.
	Diffuser (foam block) in top of food compartment is broken. (Foam blocked located in control housing)	Replace diffuser. (Top Mounts only)
	Door in damper control not closing or not closing all the way.	Replace damper control.
		Check freezer control bulb for correct positioning to ensure it is installed correctly.
	Cold air blowing into food compartment with damper door closed all the way.	Check foam seal between damper housing and cabinet liner. Check to see that the control box is mounted flush against the cabinet liner.
Evaporator blocked with ice. (See Adaptive defrost Control)	Inoperative defrost timer.	Check wiring. Repair or replace defrost timer.
	Defrost thermostat terminates too early. Thermostat is open.	Check for correct positioning of defrost thermostat. Repair or replace.
	Refrigerator/Freezer compartment doors left open.	Advise customer.
	Open defrost heater.	Replace heater.
	Air leak around ice maker fill tube, or opening.	Seal with permagum.
Frozen drain.	Ice maker water line and wiring harness openings not sealed.	Seal water line and wiring harness openings.
	Drain trough not properly formed.	Ensure drain trough is at 90° angle to back of freezer and that lip is up on front and ends.
	Divider (foam block) frozen.	Replace divider. Check drain trough.
<b>Adaptive Defrost Control (ADC)</b> not responding correctly.	Faulty ADC board.	Replace ADC board.
	Bad wire between ADC, defrost heater, and limiter.	Check wiring and wiring connectors.



PERFORMANCE DATA NO LOAD AND NO DOOR OPENINGS AT MID-POINT CONTROL SETTING		
Type A With Run Capacitor	65°F (18°C) Ambient	90°F (32°C) Ambient
Operating Time	25 to 35%	45 to 55%
Freezer Temperature	2° to 8°F -17° to -13°C	0° to 5°F -18° to -15°C
Refrigerature Temperature	35° to 40°F 2° to 4°C	35° to 40°F 2° to 4°C
Low Side Pressure (cut-in)	8 to 16 psig 55 to 110 kPa	8 to 16 psig 55 to 110 kPa
Low Side Pressure (cut-out)	1 to 4 psig 7 to 28 kPa	1 to 4 psig 7 to 28 kPa
High Side Pressure (Last 1/3 of cycle)	110 to 120 psig 758 to 827 kPa	150 to 175 psig 1034 to 1207 kPa
Wattage (Last 1/3 of cycle)	140 to 185	140 to 185
Amps (Running)	1.1 to 1.6	1.1 to 1.6
Base Voltage	115 VAC	115 VAC

DEFROST SPECIFICATIONS				
Cabinet Size	Thermostat		Heater	
	Cut-in	Cut-out	Watts	Ohms
18' & 21'	25°F -4°C	47°F 8°C	375	35
14', 15' & 17'	25°F -4°C	47°F 8°C	325	41

Mechanical Timer - Defrost 30 Minutes Every 10 Hours of Compressor Run Time  
Electronic Timer (ADC) Defrost Up To 24 Minutes Every 6 - 72 Hours of Compressor Run Time

CONDENSER FAN MOTOR		
Watts	RPM	Amps
2.3	1100 CW Opposite Shaft	.15 Running

ICE MAKER SPECIFICATIONS		
Electrical	115 Volts	60 Hertz
Thermostat	Opens at 48°F (9°C)	Closes at 15°F (-9°C)
Heater Wattage	165	

ICE MAKER CONNECTOR PLUG CONNECTIONS		
Wire Number	Wire Color	Connects to:
1	Green/Yellow	Ground
2	Yellow	Water Valve
3	Black	Line
4	Lt. Blue	Neutral

## SERVICE DATA SHEET

**STANDARD - AUTOMATIC  
DEFROST TOP FREEZER  
MODELS (R134a)**

**P/N: 240379007**

### IMPORTANT SAFETY NOTICE

The information provided herein is designed to assist qualified repair personnel only. Untrained persons should not attempt to make repairs due to the possibility of electrical shock. Disconnect power cord before servicing.

### IMPORTANT

If any green grounding wires are moved during servicing, they must be returned to their original position and properly secured.

**CAUTION: All electrical parts and wiring must be shielded from torch flame. Do not allow torch to contact insulation; it will char at 200°F and flash ignite (burn) at 500°F. Excessive heat will distort the plastic liner.**

**NOTE: This product comes equipped with an Electronic Defrost Control. To initiate defrost, depress the fresh food light switch 5 times in 6 seconds (light bulb must be working). To terminate defrost, depress the fresh food light switch 5 times in 6 seconds.**

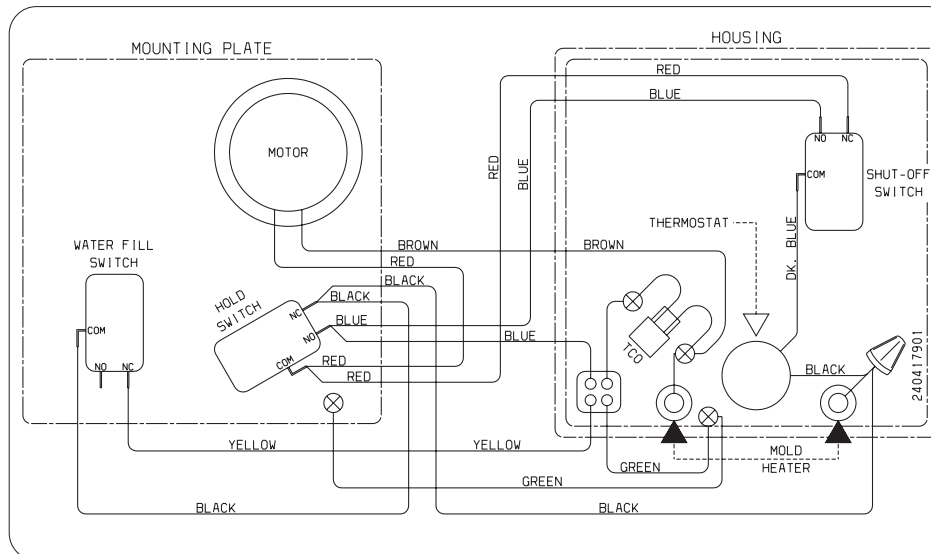

## ICE MAKER INFORMATION

### Test Cycling

Remove cover by inserting screwdriver in notch at bottom and prying cover from housing. Use screwdriver to rotate motor gear counterclockwise until *Holding Switch* circuit is completed. All components of ice maker should function to complete the cycle.

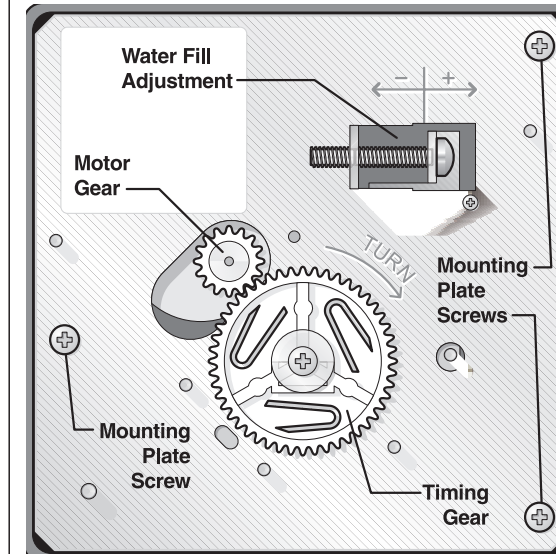

### Water Fill Volume

The water fill adjustment screw will change the fill time. One full turn is equal to 20cc (.68 oz.). The correct fill is 95 to 105cc (3.2 to 3.6 oz.). When a water valve is replaced, the fill volume must be checked.

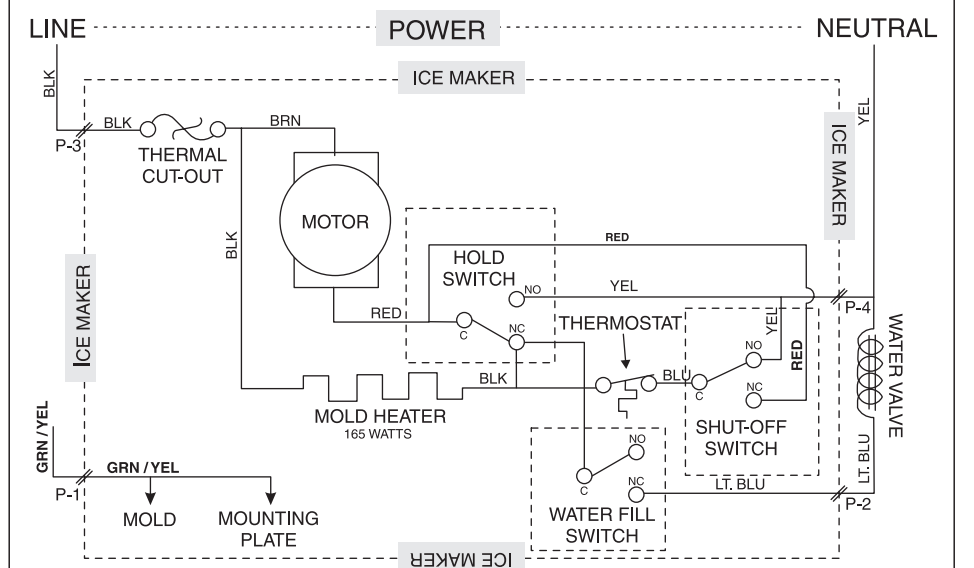



### Pictorial Schematic

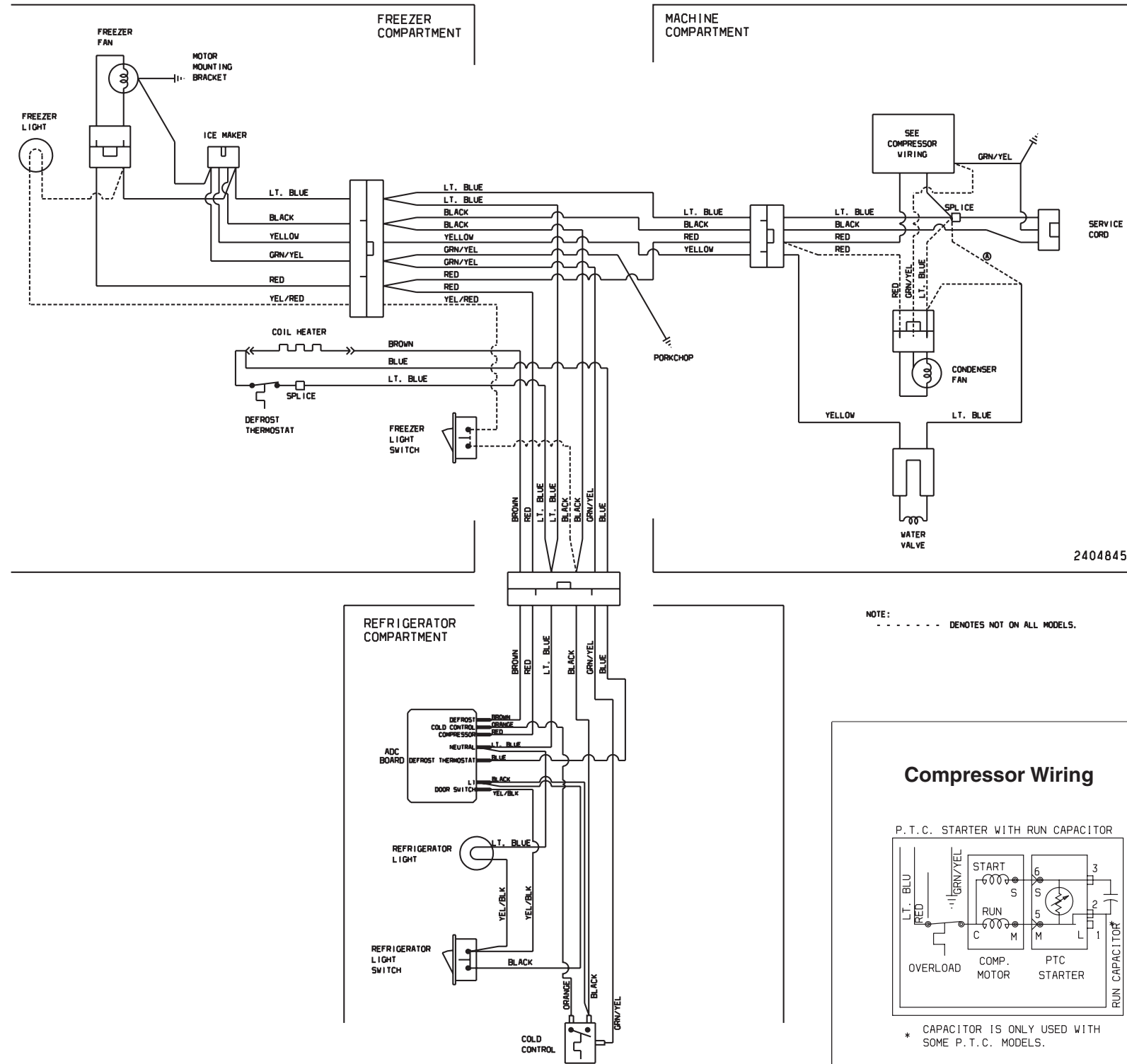

### Ladder Schematic

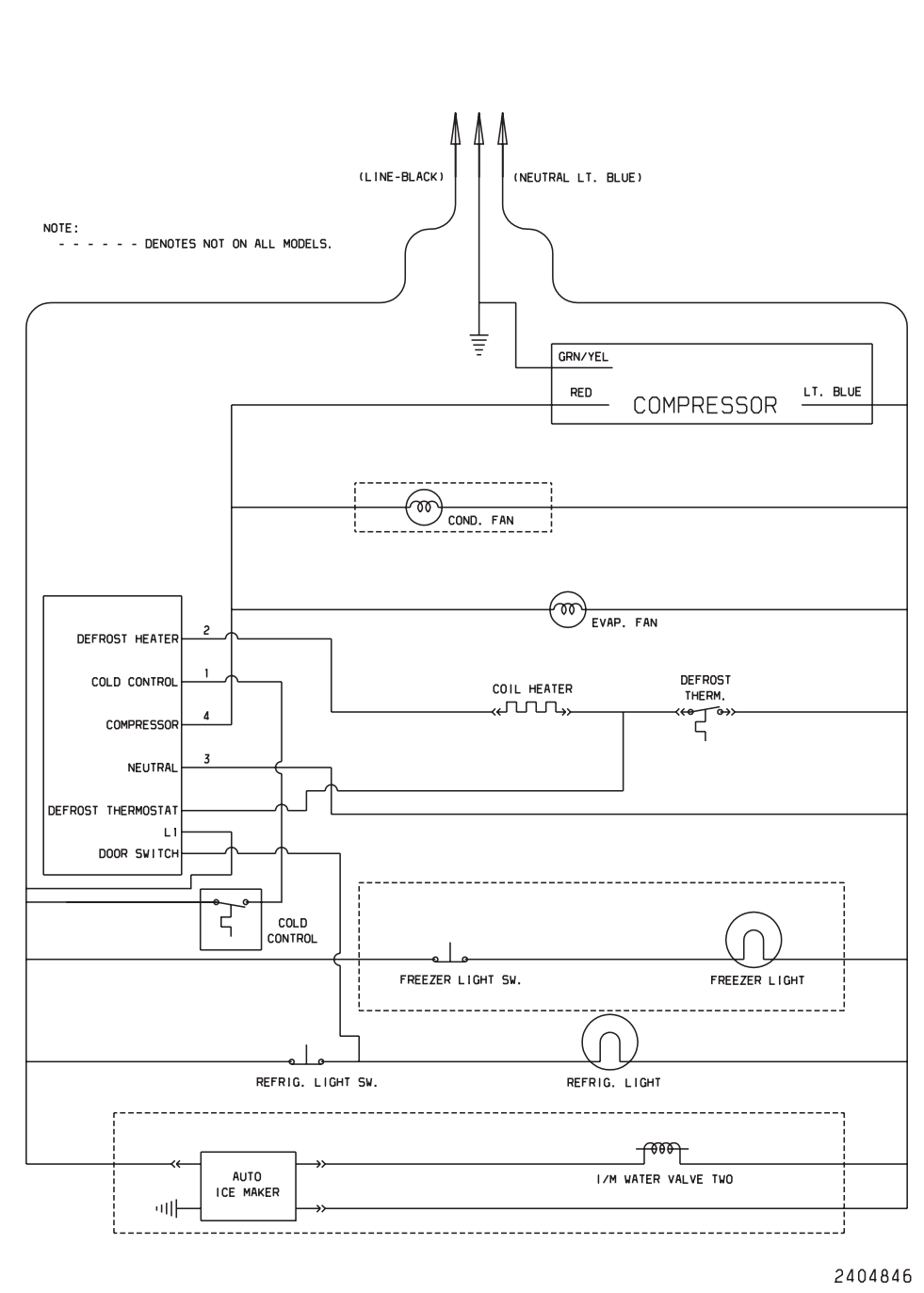

### Compressor Wiring

P. T. C. STARTER WITH RUN CAPACITOR

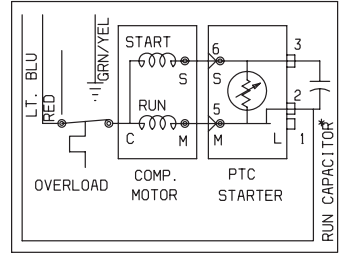

\* CAPACITOR IS ONLY USED WITH SOME P. T. C. MODELS.

PERFORMANCE DATA NO LOAD AND NO DOOR OPENINGS AT MID-POINT CONTROL SETTING		
Type A With Run Capacitor	65°F (18°C) Ambient	90°F (32°C) Ambient
Operating Time	25 to 35%	45 to 55%
Freezer Temperature	2° to 8°F -17° to -13°C	0° to 5°F -18° to -15°C
Refrigerature Temperature	35° to 40°F 2° to 4°C	35° to 40°F 2° to 4°C
Low Side Pressure (cut-in)	8 to 16 psig 55 to 110 kPa	8 to 16 psig 55 to 110 kPa
Low Side Pressure (cut-out)	1 to 4 psig 7 to 28 kPa	1 to 4 psig 7 to 28 kPa
High Side Pressure (Last 1/3 of cycle)	110 to 120 psig 758 to 827 kPa	150 to 175 psig 1034 to 1207 kPa
Wattage (Last 1/3 of cycle)	140 to 185	140 to 185
Amps (Running)	1.1 to 1.6	1.1 to 1.6
Base Voltage	115 VAC (127 VAC Max)	115 VAC (127 VAC Max)

DEFROST SPECIFICATIONS				
Cabinet Size	Thermostat		Heater	
	Cut-in	Cut-out	Watts	Ohms
18' & 21'	25°F -4°C	47°F 8°C	375	35
14', 15' & 17'	25°F -4°C	47°F 8°C	325	41

Mechanical Timer - Defrost 30 Minutes Every 10 Hours of Compressor Run Time  
Electronic Timer (ADC) Defrost Up To 24 Minutes Every 6 - 72 Hours of Compressor Run Time

CONDENSER FAN MOTOR		
Watts	RPM	Amps
2.3	1100 CW Opposite Shaft	.15 Running

ICE MAKER SPECIFICATIONS		
Electrical	115 VAC (127 VAC Max)	60 Hertz
Thermostat	Opens at 48°F (9°C)	Closes at 15°F (-9°C)
Heater Wattage	165	

ICE MAKER CONNECTOR PLUG CONNECTIONS		
Wire Number	Wire Color	Connects to:
1	Green/Yellow	Ground
2	Yellow	Water Valve
3	Black	Line
4	Lt. Blue	Neutral

## SERVICE DATA SHEET

STANDARD - AUTOMATIC  
DEFROST TOP FREEZER  
MODELS (R134a)

P/N: 240379011

### IMPORTANT SAFETY NOTICE

The information provided herein is designed to assist qualified repair personnel only. Untrained persons should not attempt to make repairs due to the possibility of electrical shock. Disconnect power cord before servicing.

### IMPORTANT

If any green grounding wires are moved during servicing, they must be returned to their original position and properly secured.

**CAUTION: All electrical parts and wiring must be shielded from torch flame. Do not allow torch to contact insulation; it will char at 200°F and flash ignite (burn) at 500°F. Excessive heat will distort the plastic liner.**

**NOTE: This product comes equipped with an Electronic Defrost Control. To initiate defrost, depress the fresh food light switch 5 times in 6 seconds (light bulb must be working). To terminate defrost, depress the fresh food light switch 5 times in 6 seconds.**

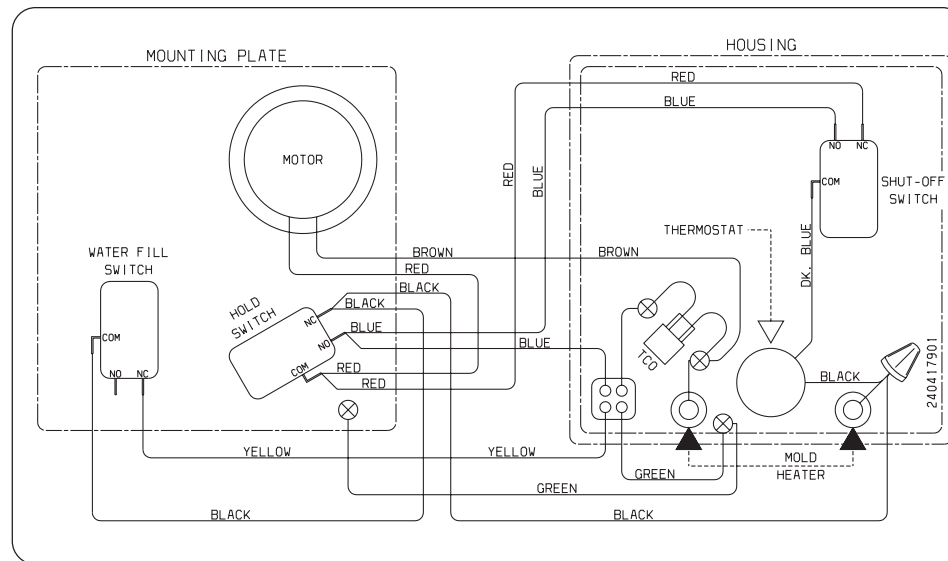

## ICE MAKER INFORMATION

### Test Cycling

Remove cover by inserting screwdriver in notch at bottom and prying cover from housing. Use screwdriver to rotate motor gear counterclockwise until holding switch circuit is completed. All components of ice maker should function to complete the cycle.

### Water Fill Volume

The water fill adjustment screw will change the fill time. One full turn is equal to 20cc (.68 oz.). The correct fill is 102 to 130cc (3.4 to 4.3 oz.). When a water valve is replaced, the fill volume must be checked.

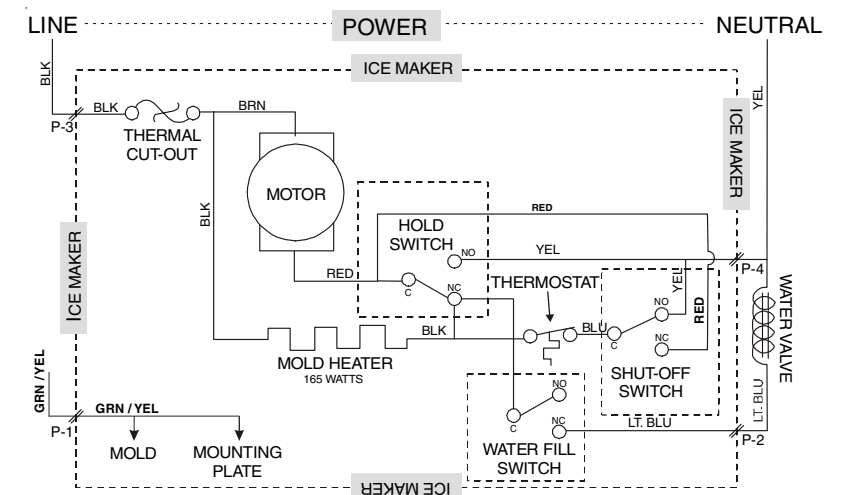
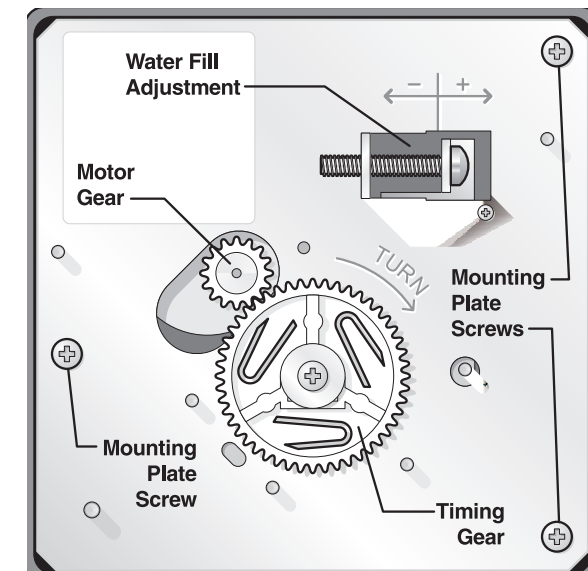

### Pictorial Schematic

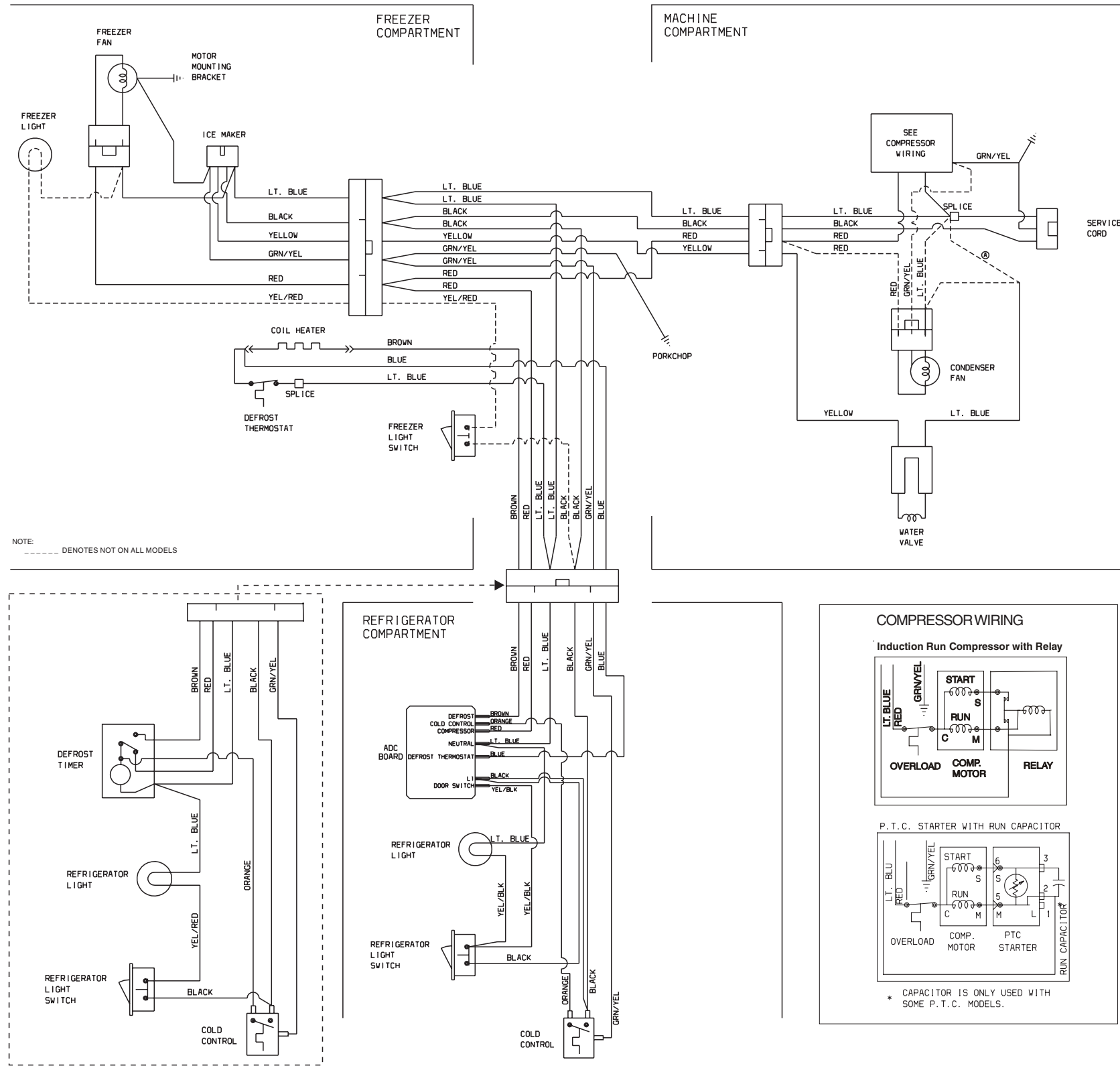

### Ladder Schematic

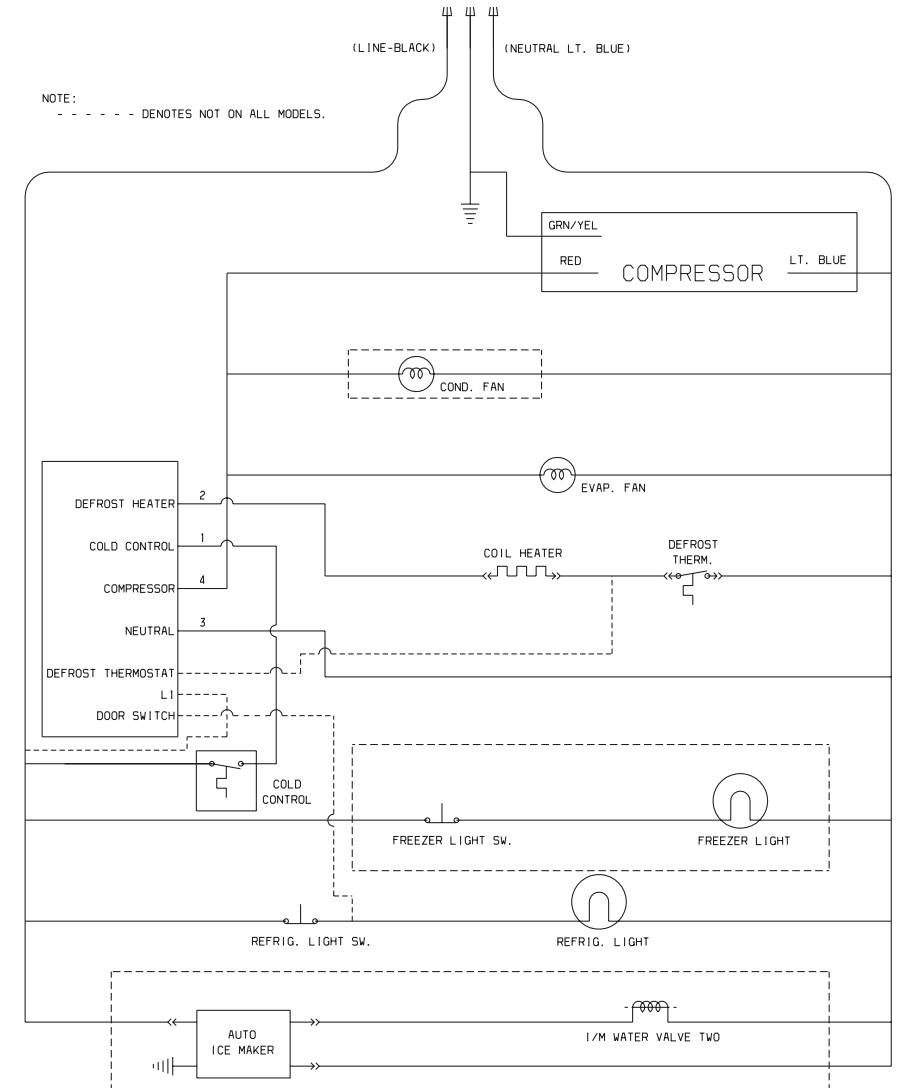

SERVICE PARTS	15 & 17 CUBIC FOOT			18 CUBIC FOOT			21 CUBIC FOOT	
	STATIC	DYNAMIC	E-STAR	STATIC	DYNAMIC	E-STAR	DYNAMIC	E-STAR
Compressor / Kit *	5303918264	5303918264	5303918295	240435705	240435705	5303918295	5303918264	5303918295
Starter/PTC *	218721120	218721120	218721120	218721120	218721120	218721120	218721120	218721120
Run Capacitor *	218909913	218909913	218909912	218909913	218909913	218909912	218909913	218909912
Relay	N/A	N/A	N/A	5304433579	5304433579	N/A	N/A	N/A
Overload	N/A	N/A	N/A	5304433578	5304433578	N/A	N/A	N/A
Temperature Control	5304421256	5304421256	5304421256	5304421256	5304421256	5304421256	5304421256	5304421256
Timer (if applicable)	215846606	215846606	215846606	215846606	215846606	215846606	215846606	215846606
ADC (if applicable)	N/A	N/A	N/A	N/A	N/A	N/A	N/A	N/A
Defrost Heater Kit	5303918203	5303918203	5303918203	5303918208	5303918208	5303918208	5303918247	5303918247
Defrost Thermostat Kit	5303918202	5303918202	5303918202	5303918202	5303918202	5303918202	5303918202	5303918202
Evaporator Fan Motor	240369701	240369701	240369701	240369701	240369701	240369701	240369701	240369701
Condenser Fan Motor	N/A	240523601	240523601	N/A	240523601	240523601	240334001	240334001

PERFORMANCE DATA NO LOAD AND NO DOOR OPENINGS AT MID-POINT CONTROL SETTING		
Type A With Run Capacitor	65°F (18°C) Ambient	90°F (32°C) Ambient
Operating Time	25 to 35%	45 to 55%
Freezer Temperature	2° to 8°F -17° to -13°C	0° to 5°F -18° to -15°C
Refrigerature Temperature	35° to 40°F 2° to 4°C	35° to 40°F 2° to 4°C
Low Side Pressure (cut-in)	8 to 16 psig 55 to 110 kPa	8 to 16 psig 55 to 110 kPa
Low Side Pressure (cut-out)	1 to 4 psig 7 to 28 kPa	1 to 4 psig 7 to 28 kPa
High Side Pressure (Last 1/3 of cycle)	110 to 120 psig 758 to 827 kPa	150 to 175 psig 1034 to 1207 kPa
Wattage (Last 1/3 of cycle)	140 to 185	140 to 185
Amps (Running)	1.1 to 1.6	1.1 to 1.6
Base Voltage	115 VAC (127 VAC Max)	115 VAC (127 VAC Max)

DEFROST SPECIFICATIONS				
Cabinet Size	Thermostat		Heater	
	Cut-in	Cut-out	Watts	Ohms
18' & 21'	25°F -4°C	47°F 8°C	375	35
14', 15' & 17'	25°F -4°C	47°F 8°C	325	41

Mechanical Timer - Defrost 30 Minutes Every 10 Hours of Compressor Run Time  
Electronic Timer (ADC) Defrost Up To 24 Minutes Every 6 - 72 Hours of Compressor Run Time

CONDENSER FAN MOTOR		
Watts	RPM	Amps
2.3	1100 CW Opposite Shaft	.15 Running

ICE MAKER SPECIFICATIONS		
Electrical	115 VAC (127 VAC Max)	60 Hertz
Thermostat	Opens at 48°F (9°C)	Closes at 15°F (-9°C)
Heater Wattage	165	

ICE MAKER CONNECTOR PLUG CONNECTIONS		
Wire Number	Wire Color	Connects to:
1	Green/Yellow	Ground
2	Yellow	Water Valve
3	Black	Line
4	Lt. Blue	Neutral

## SERVICE DATA SHEET

STANDARD - AUTOMATIC  
DEFROST TOP FREEZER  
MODELS (R134a)

P/N: 240379012

### IMPORTANT SAFETY NOTICE

The information provided herein is designed to assist qualified repair personnel only. Untrained persons should not attempt to make repairs due to the possibility of electrical shock. Disconnect power cord before servicing.

### IMPORTANT

If any green grounding wires are moved during servicing, they must be returned to their original position and properly secured.

**CAUTION: All electrical parts and wiring must be shielded from torch flame. Do not allow torch to contact insulation; it will char at 200°F and flash ignite (burn) at 500°F. Excessive heat will distort the plastic liner.**

**NOTE: This product comes equipped with an Electronic Defrost Control. To initiate defrost, depress the fresh food light switch 5 times in 6 seconds (light bulb must be working). To terminate defrost, depress the fresh food light switch 5 times in 6 seconds.**

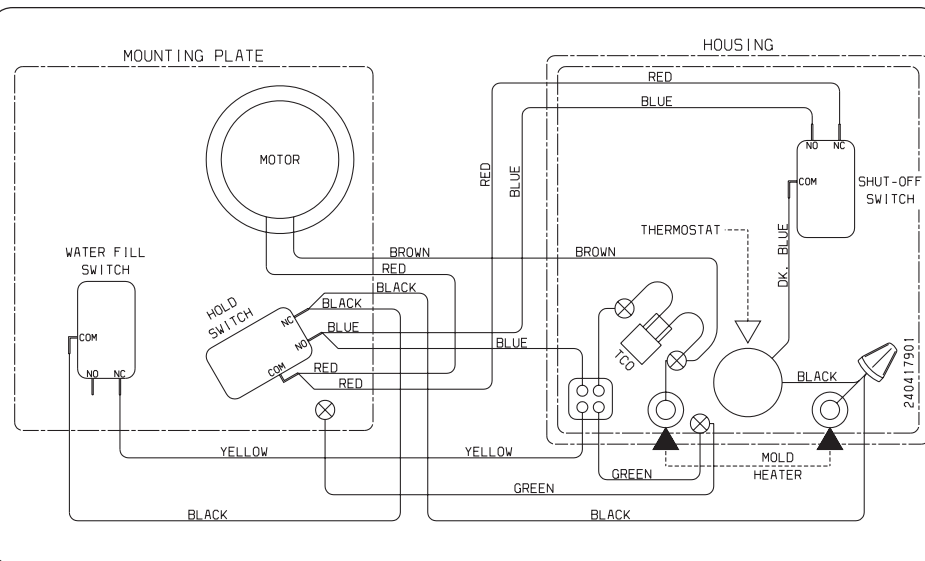

## ICE MAKER INFORMATION

### Test Cycling

Remove cover by inserting screwdriver in notch at bottom and prying cover from housing. Use screwdriver to rotate motor gear counterclockwise until holding switch circuit is completed. All components of ice maker should function to complete the cycle.

### Water Fill Volume

The water fill adjustment screw will change the fill time. One full turn is equal to 20cc (.68 oz.). The correct fill is 102 to 130cc (3.4 to 4.3 oz.). When a water valve is replaced, the fill volume must be checked.

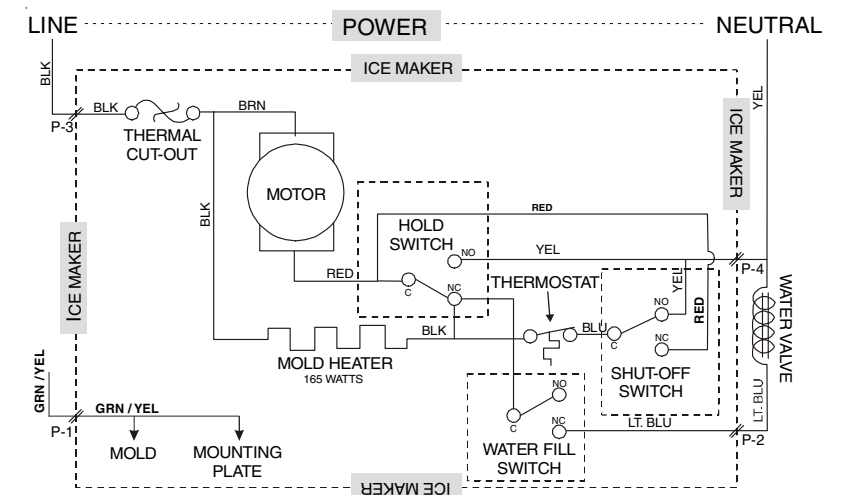
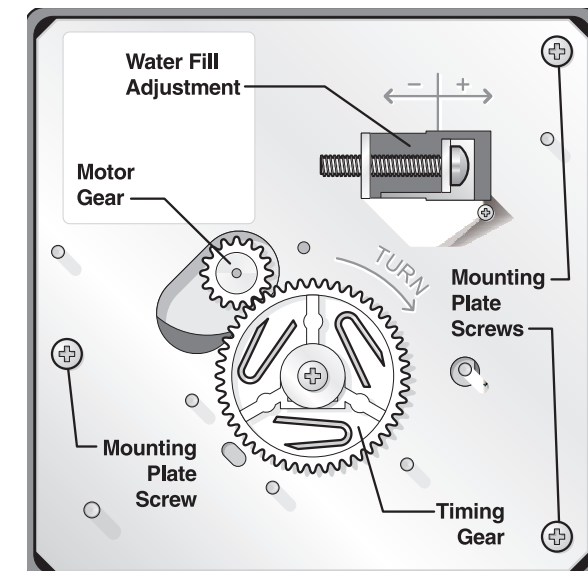

### Pictorial Schematic

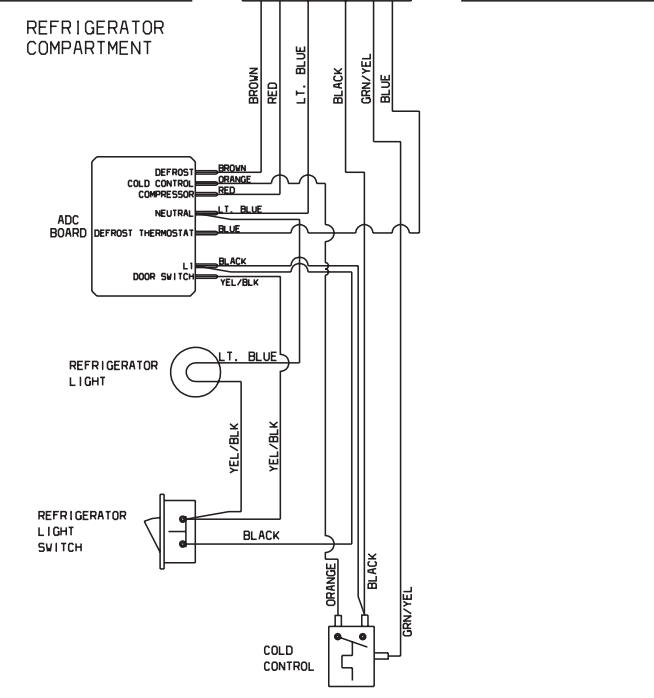
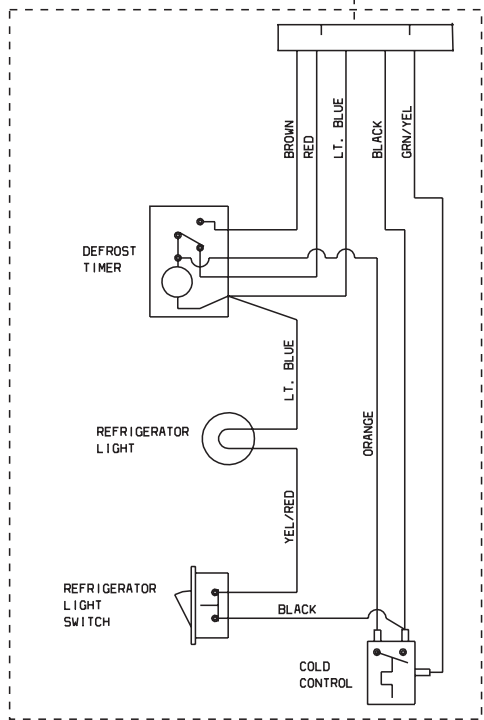
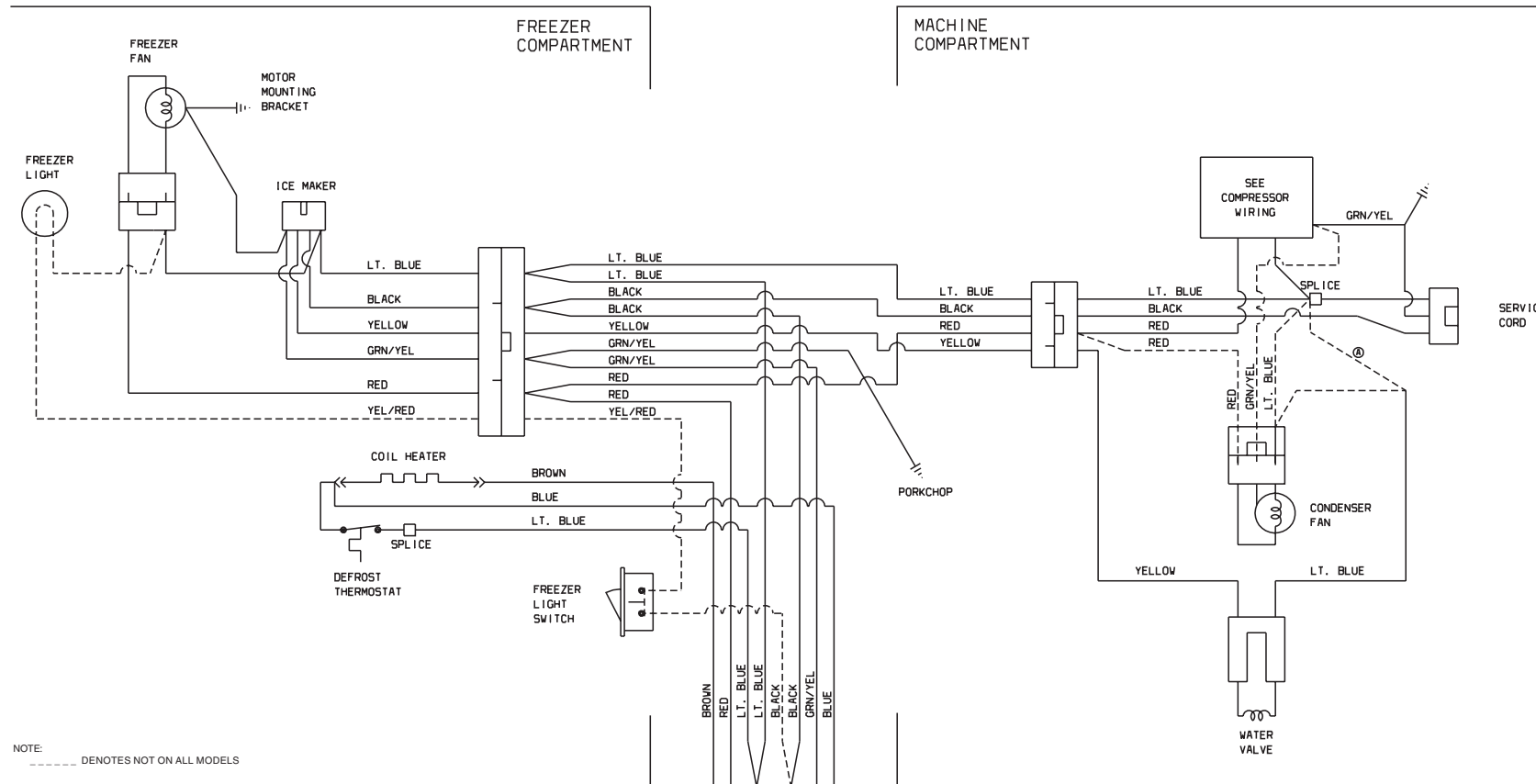

### COMPRESSOR WIRING

Induction Run Compressor with Relay

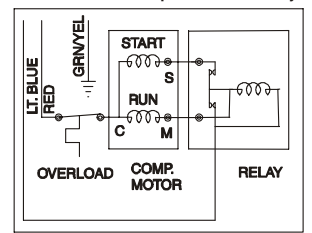

P.T.C. STARTER WITH RUN CAPACITOR

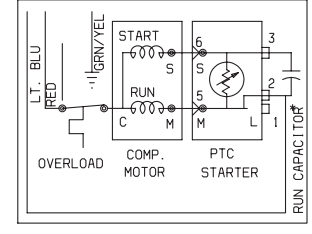

\* CAPACITOR IS ONLY USED WITH SOME P.T.C. MODELS.

### Ladder Schematic

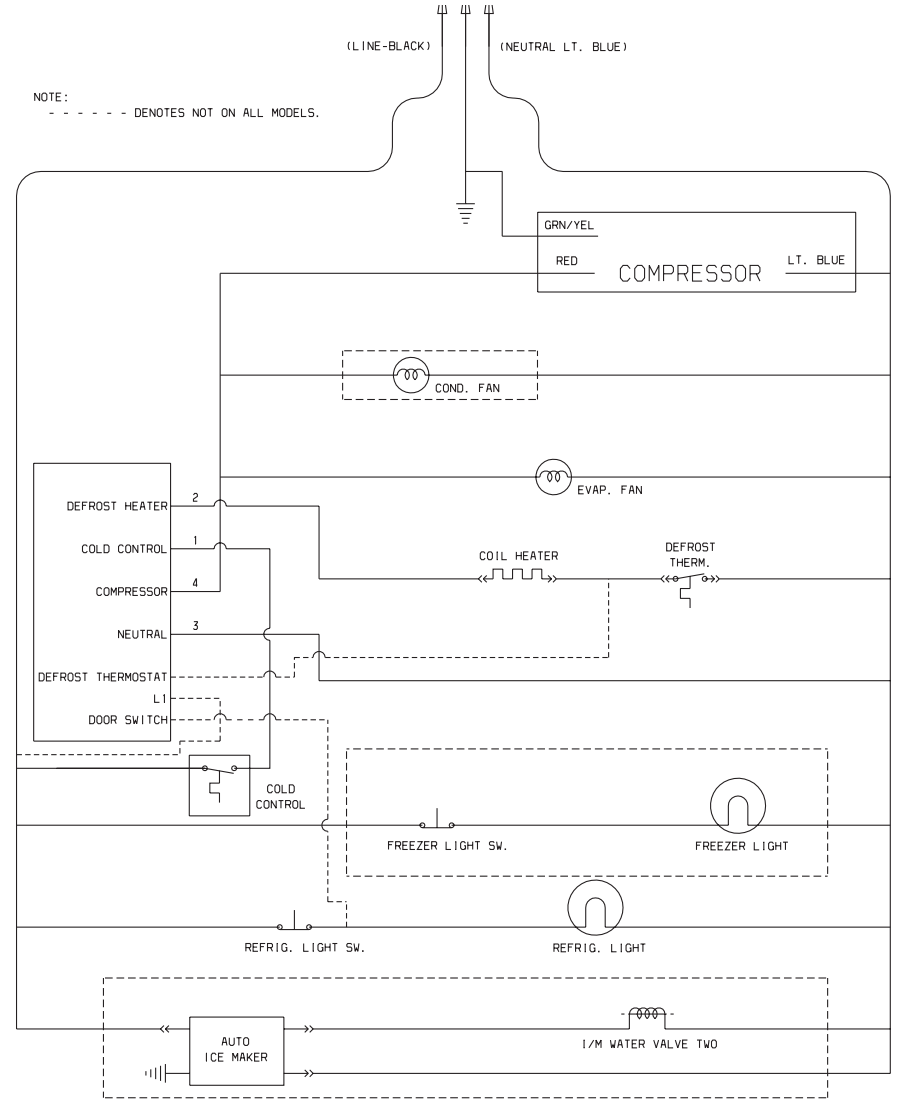

SERVICE PARTS	15 & 17 CUBIC FOOT			18 CUBIC FOOT			21 CUBIC FOOT	
	STATIC	DYNAMIC	E-STAR	STATIC	DYNAMIC	E-STAR	DYNAMIC	E-STAR
Compressor / Kit *	5303918264	5303918264	5303918295	5303918297	5303918297	5303918251	5303918297	5303918251
Starter/PTC *	218721120	218721120	218721120	N/A	N/A	218721119	N/A	218721119
Run Capacitor *	218909913	218909913	218909912	N/A	N/A	218909913	N/A	218909913
Relay	N/A	N/A	N/A	5304433579	5304433579	N/A	5304433579	N/A
Overload	N/A	N/A	N/A	5304433578	5304433578	N/A	5304433578	N/A
Temperature Control	5304421256	5304421256	5304421256	5304421256	5304421256	5304421256	5304421256	5304421256
Timer (if applicable)	215846606	215846606	215846606	215846606	215846606	215846606	215846606	215846606
ADC (if applicable)	N/A	N/A	N/A	N/A	N/A	N/A	N/A	N/A
Defrost Heater Kit	5303918203	5303918203	5303918203	5303918208	5303918208	5303918208	5303918247	5303918247
Defrost Thermostat Kit	5303918202	5303918202	5303918202	5303918202	5303918202	5303918202	5303918202	5303918202
Evaporator Fan Motor	240369701	240369701	240369701	240369701	240369701	240369701	240369701	240369701
Condenser Fan Motor	N/A	240523601	240523601	N/A	240523601	240523601	240334001	240334001

\* Typical compressor kit includes compressor, electrical components, and filter-drier



PERFORMANCE DATA NO LOAD AND NO DOOR OPENINGS AT MID-POINT CONTROL SETTING		
Type A With Run Capacitor	65°F (18°C) Ambient	90°F (32°C) Ambient
Operating Time	25 to 35%	45 to 55%
Freezer Temperature	2° to 8°F -17° to -13°C	0° to 5°F -18° to -15°C
Refrigerature Temperature	35° to 40°F 2° to 4°C	35° to 40°F 2° to 4°C
Low Side Pressure (cut-in)	8 to 16 psig 55 to 110 kPa	8 to 16 psig 55 to 110 kPa
Low Side Pressure (cut-out)	1 to 4 psig 7 to 28 kPa	1 to 4 psig 7 to 28 kPa
High Side Pressure (Last 1/3 of cycle)	110 to 120 psig 758 to 827 kPa	150 to 175 psig 1034 to 1207 kPa
Wattage (Last 1/3 of cycle)	140 to 185	140 to 185
Amps (Running)	1.1 to 1.6	1.1 to 1.6
Base Voltage	115 VAC (127 VAC Max)	115 VAC (127 VAC Max)

DEFROST SPECIFICATIONS				
Cabinet Size	Thermostat		Heater	
	Cut-in	Cut-out	Watts	Ohms
18' & 21'	25°F -4°C	47°F 8°C	375	35
14', 15' & 17'	25°F -4°C	47°F 8°C	325	41

Mechanical Timer - Defrost 30 Minutes Every 10 Hours of Compressor Run Time  
Electronic Timer (ADC) Defrost Up To 24 Minutes Every 6 - 72 Hours of Compressor Run Time

CONDENSER FAN MOTOR		
Watts	RPM	Amps
2.3	1100 CW Opposite Shaft	.15 Running

ICE MAKER SPECIFICATIONS		
Electrical	115 VAC (127 VAC Max)	60 Hertz
Thermostat	Opens at 48°F (9°C)	Closes at 15°F (-9°C)
Heater Wattage	165	

ICE MAKER CONNECTOR PLUG CONNECTIONS		
Wire Number	Wire Color	Connects to:
1	Green/Yellow	Ground
2	Yellow	Water Valve
3	Black	Line
4	Lt. Blue	Neutral

## SERVICE DATA SHEET

STANDARD - AUTOMATIC  
DEFROST TOP FREEZER  
MODELS (R134a)

P/N: 240379013

### IMPORTANT SAFETY NOTICE

The information provided herein is designed to assist qualified repair personnel only. Untrained persons should not attempt to make repairs due to the possibility of electrical shock. Disconnect power cord before servicing.

### IMPORTANT

If any green grounding wires are moved during servicing, they must be returned to their original position and properly secured.

**CAUTION: All electrical parts and wiring must be shielded from torch flame. Do not allow torch to contact insulation; it will char at 200°F and flash ignite (burn) at 500°F. Excessive heat will distort the plastic liner.**

**NOTE: This product comes equipped with an Electronic Defrost Control. To initiate defrost, depress the fresh food light switch 5 times in 6 seconds (light bulb must be working). To terminate defrost, depress the fresh food light switch 5 times in 6 seconds.**

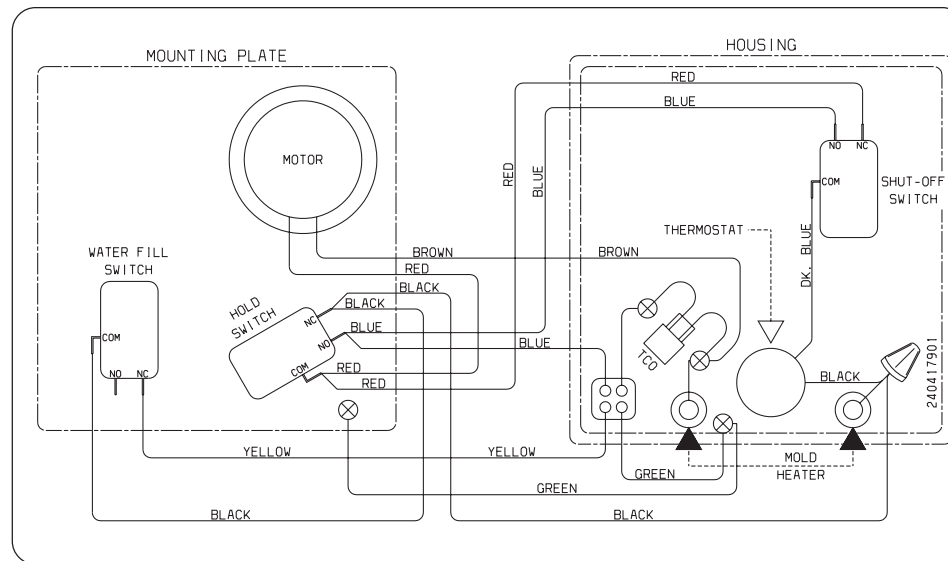

## ICE MAKER INFORMATION

### Test Cycling

Remove cover by inserting screwdriver in notch at bottom and prying cover from housing. Use screwdriver to rotate motor gear counterclockwise until holding switch circuit is completed. All components of ice maker should function to complete the cycle.

### Water Fill Volume

The water fill adjustment screw will change the fill time. One full turn is equal to 20cc (.68 oz.). The correct fill is 102 to 130cc (3.4 to 4.3 oz.). When a water valve is replaced, the fill volume must be checked.

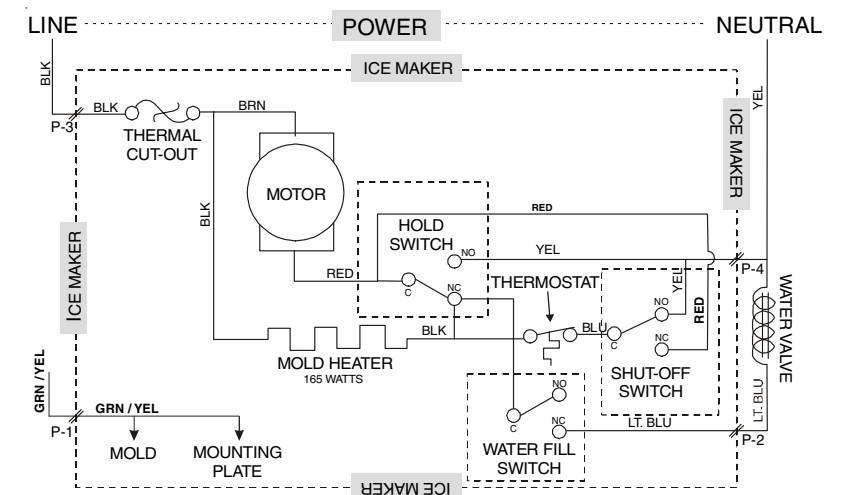
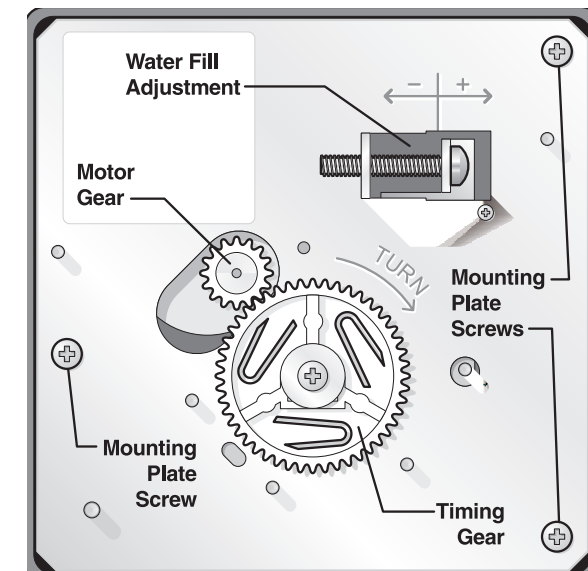

### Pictorial Schematic

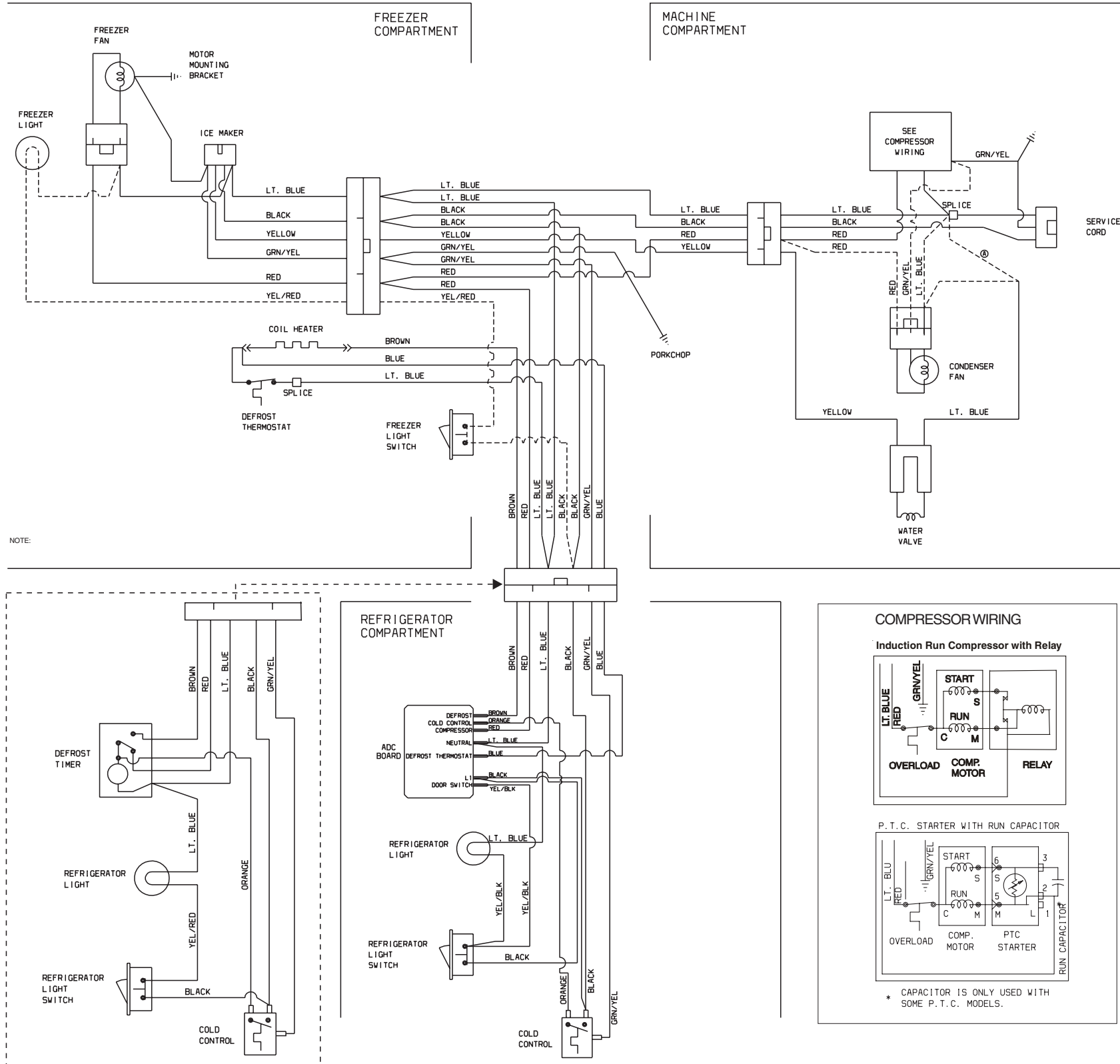

### Ladder Schematic

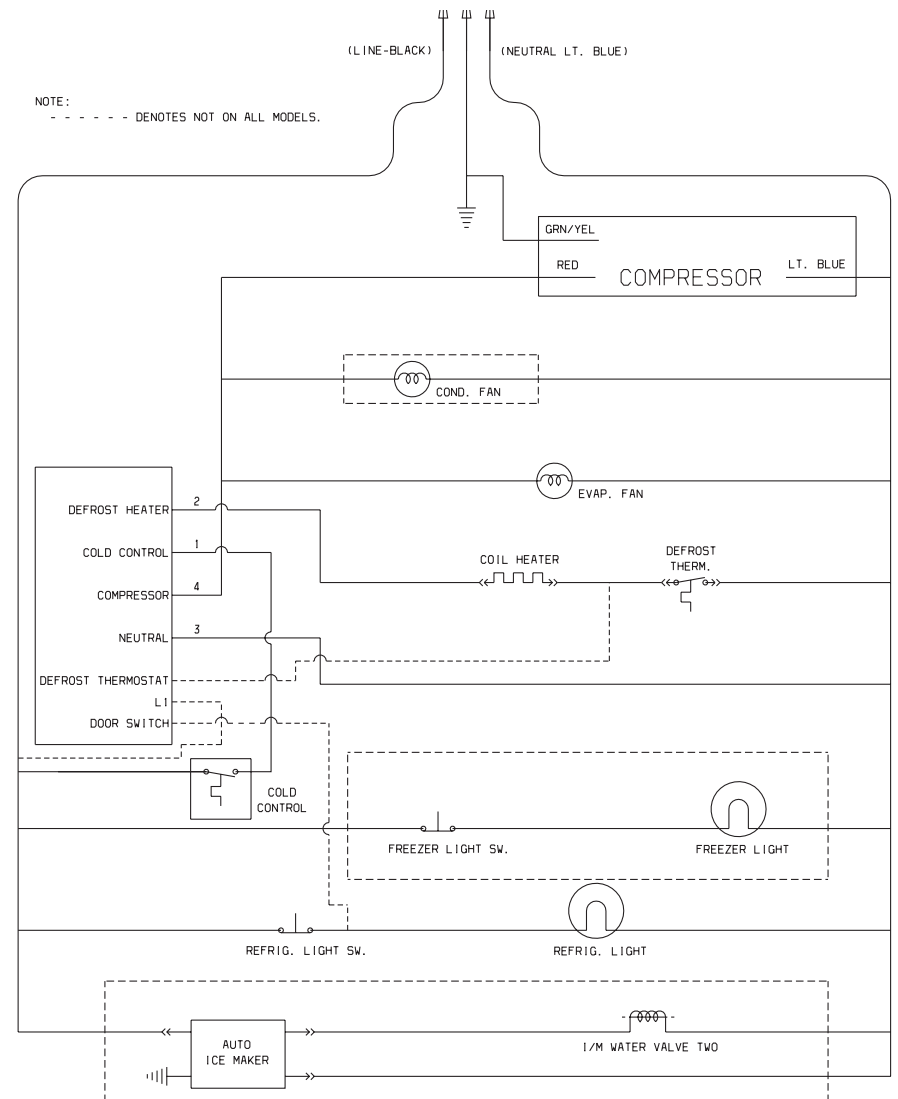

SERVICE PARTS	15 & 17 CUBIC FOOT			18 CUBIC FOOT			21 CUBIC FOOT	
	STATIC	DYNAMIC	E-STAR	STATIC	DYNAMIC	E-STAR	DYNAMIC	E-STAR
Compressor / Kit *	5303918264	5303918264	5303918299	5303918297	5303918297	5303918299	5303918297	5303918299
Starter/PTC/ITS *	218721120	218721120	241527802	N/A	N/A	241527802	N/A	241527802
Run Capacitor *	218909913	218909913	218909915	N/A	N/A	218909915	N/A	218909915
Relay	N/A	N/A	N/A	5304433579	5304433579	N/A	5304433579	N/A
Overload	N/A	N/A	N/A	5304433578	5304433578	N/A	5304433578	N/A
Temperature Control	5304421256	5304421256	5304421256	5304421256	5304421256	5304421256	5304421256	5304421256
Timer (if applicable)	215846606	215846606	215846606	215846606	215846606	215846606	215846606	215846606
ADC (if applicable)	N/A	N/A	N/A	N/A	N/A	N/A	N/A	N/A
Defrost Heater Kit	5303918203	5303918203	5303918203	5303918208	5303918208	5303918208	5303918247	5303918247
Defrost Thermostat Kit	5303918202	5303918202	5303918202	5303918202	5303918202	5303918202	5303918202	5303918202
Evaporator Fan Motor	240369701	240369701	240369701	240369701	240369701	240369701	240369701	240369701
Condenser Fan Motor	N/A	240523601	240523601	N/A	240523601	240523601	240334001	240334001

\* Typical compressor kit includes compressor, electrical components, and filter-drier

PERFORMANCE DATA NO LOAD AND NO DOOR OPENINGS AT MID-POINT CONTROL SETTING		
Capacitor Run or Induction Run	65°F (18°C) Ambient	90°F (32°C) Ambient
Operating Time	25 to 35%	45 to 55%
Freezer Temperature	2° to 8°F -17° to -13°C	0° to 5°F -18° to -15°C
Refrigerature Temperature	35° to 40°F 2° to 4°C	35° to 40°F 2° to 4°C
Low Side Pressure (cut-in)	8 to 16 psig 55 to 110 kPa	8 to 16 psig 55 to 110 kPa
Low Side Pressure (cut-out)	1 to 4 psig 7 to 28 kPa	1 to 4 psig 7 to 28 kPa
High Side Pressure (Last 1/3 of cycle)	110 to 120 psig 758 to 827 kPa	150 to 175 psig 1034 to 1207 kPa
Wattage (Last 1/3 of cycle)	140 to 185	140 to 185
Amps (Running)	1.1 to 1.6	1.1 to 1.6
Base Voltage	115 VAC (127 VAC Max)	115 VAC (127 VAC Max)

DEFROST SPECIFICATIONS				
Cabinet Size	Thermostat		Heater	
	Cut-in	Cut-out	Watts	Ohms
18' & 21'	25°F -4°C	47°F 8°C	375	35
14', 15' & 17'	25°F -4°C	47°F 8°C	325	41

Mechanical Timer - Defrost 30 Minutes Every 10 Hours of Compressor Run Time  
Electronic Timer (ADC) Defrost Up To 24 Minutes Every 6 - 72 Hours of Compressor Run Time

CONDENSER FAN MOTOR		
Watts	RPM	Amps
2.3	1100 CW Opposite Shaft	.15 Running

ICE MAKER SPECIFICATIONS		
Electrical	115 VAC (127 VAC Max)	60 Hertz
Thermostat	Opens at 48°F (9°C)	Closes at 15°F (-9°C)
Heater Wattage	165	

ICE MAKER CONNECTOR PLUG CONNECTIONS		
Wire Number	Wire Color	Connects to:
1	Green/Yellow	Ground
2	Yellow	Water Valve
3	Black	Line
4	Lt. Blue	Neutral

## SERVICE DATA SHEET

STANDARD - AUTOMATIC  
DEFROST TOP FREEZER MODELS (R134a) | P/N: 240379014

### IMPORTANT SAFETY NOTICE

The information provided herein is designed to assist qualified repair personnel only. Untrained persons should not attempt to make repairs due to the possibility of electrical shock. Disconnect power cord before servicing.

### IMPORTANT

If any green grounding wires are moved during servicing, they must be returned to their original position and properly secured.

**CAUTION: All electrical parts and wiring must be shielded from torch flame. Do not allow torch to contact insulation; it will char at 200°F and flash ignite (burn) at 500°F. Excessive heat will distort the plastic liner.**

**NOTE: Some products come equipped with an Electronic Defrost Control. To initiate defrost, depress the fresh food light switch 5 times in 6 seconds (light bulb must be working). To terminate defrost, depress the fresh food light switch 5 times in 6 seconds.**

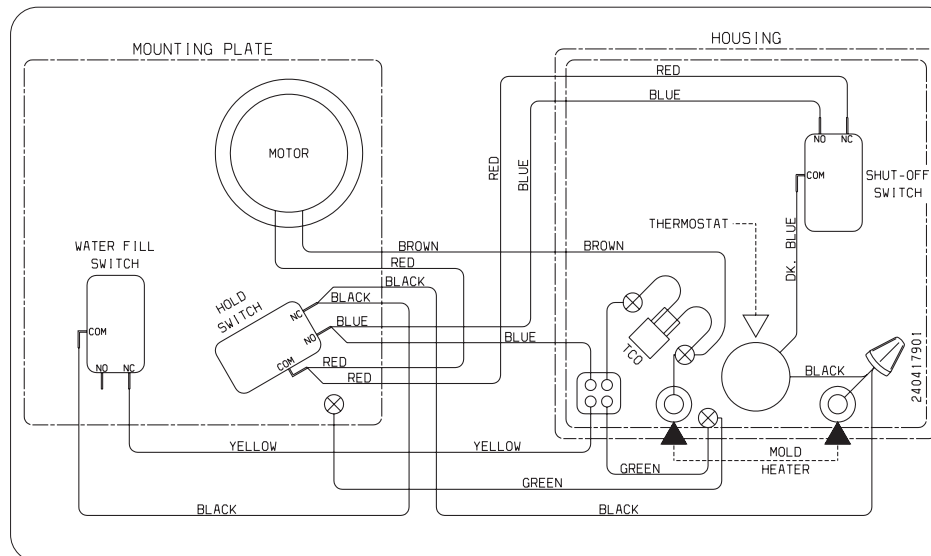

## ICE MAKER INFORMATION

### Test Cycling

Remove cover by inserting screwdriver in notch at bottom and prying cover from housing. Use screwdriver to rotate motor gear counterclockwise until *Holding Switch* circuit is completed. All components of ice maker should function to complete the cycle.

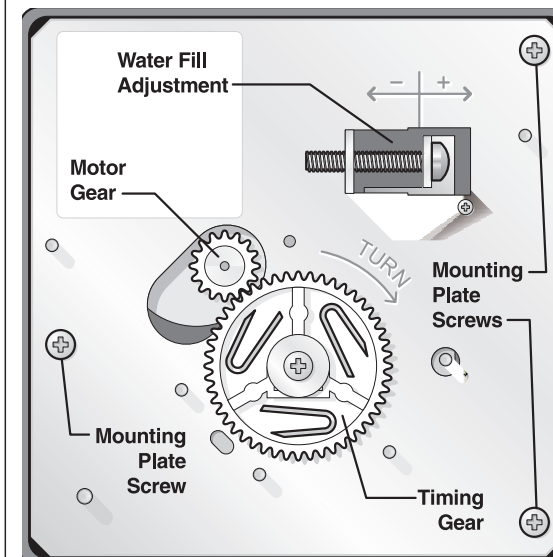

### Water Fill Volume

The water fill adjustment screw will change the fill time. One full turn is equal to 20cc (.68 oz.). The correct fill is 95 to 105cc (3.2 to 3.6 oz.). When a water valve is replaced, the fill volume must be checked.

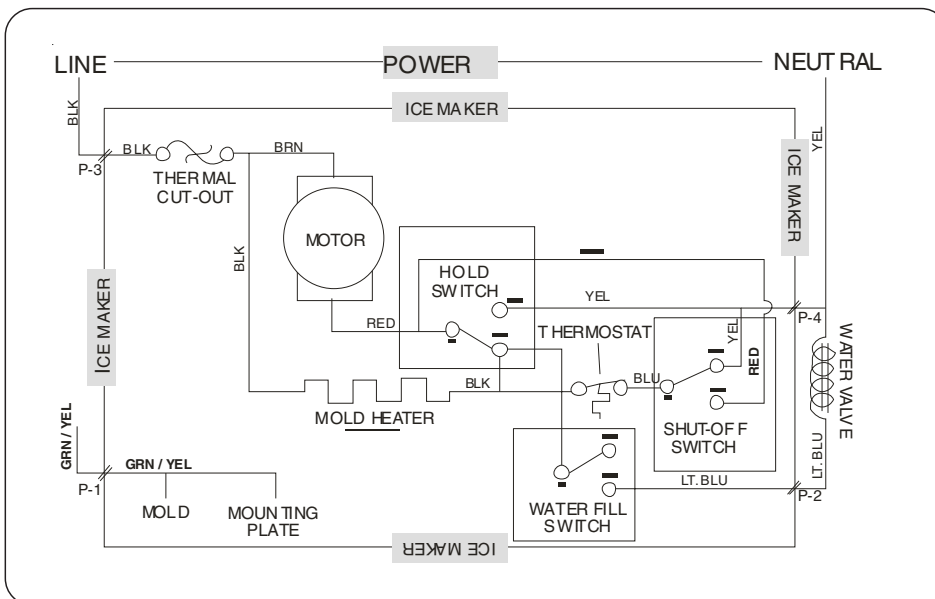



### Pictorial Schematic

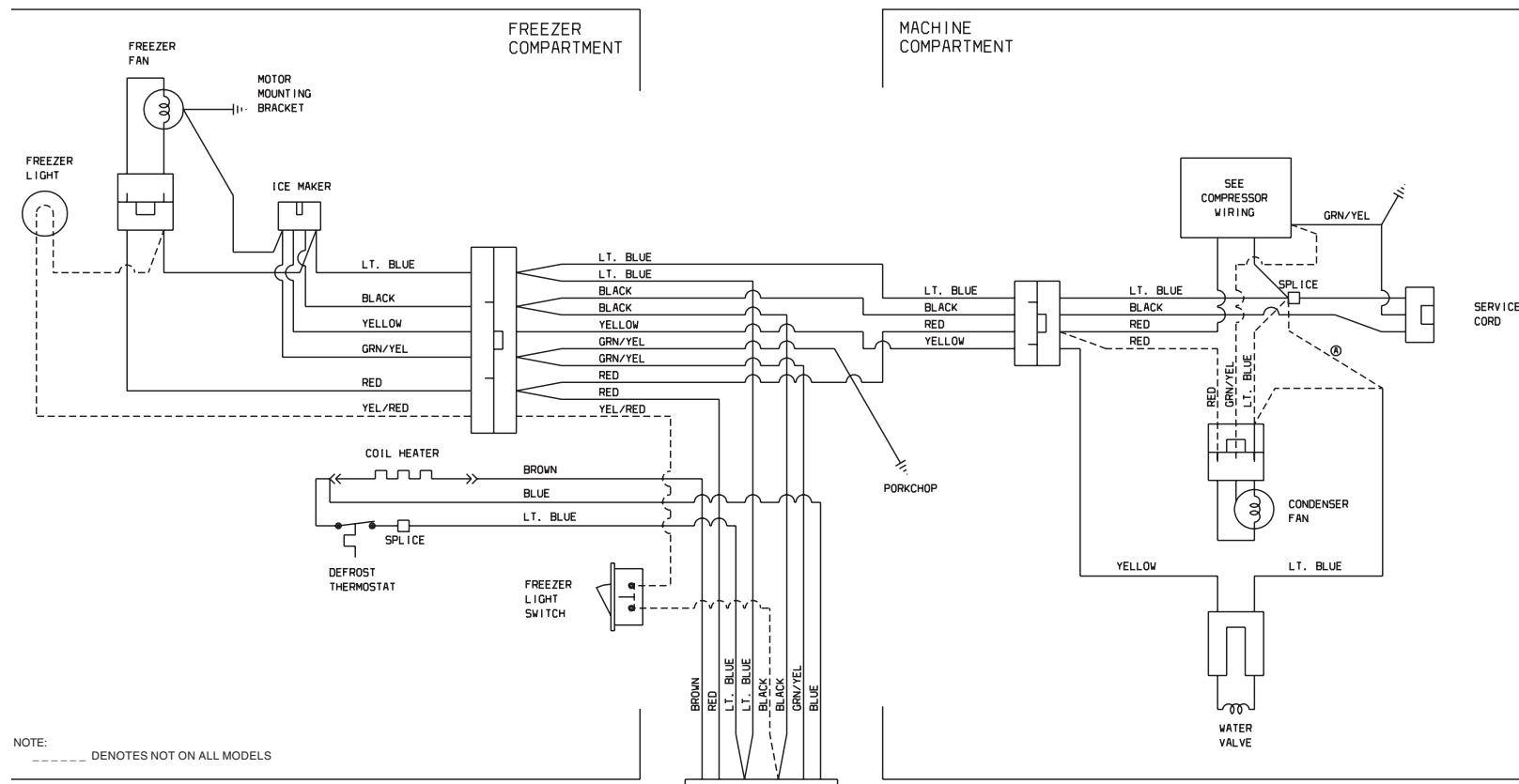

NOTE: ----- DENOTES NOT ON ALL MODELS

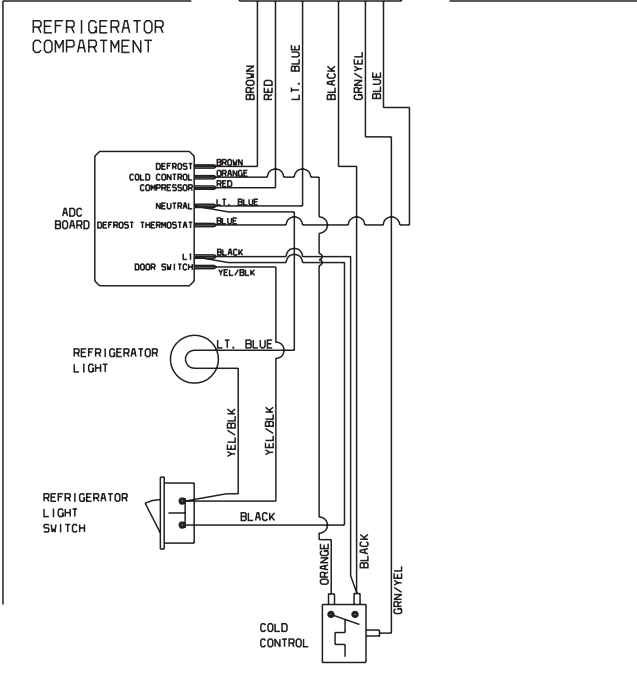
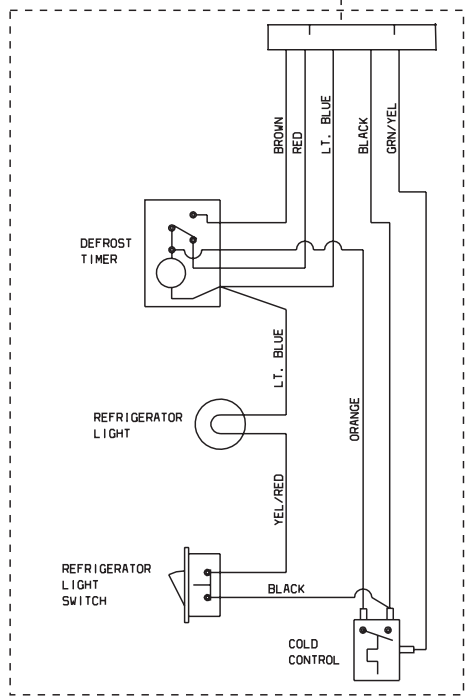

### COMPRESSOR WIRING

Induction Run Compressor with Relay

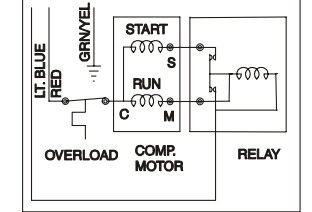

P.T.C. STARTER WITH RUN CAPACITOR

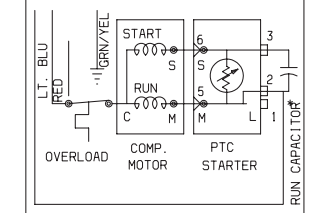

\* CAPACITOR IS ONLY USED WITH SOME P.T.C. MODELS.

### Ladder Schematic

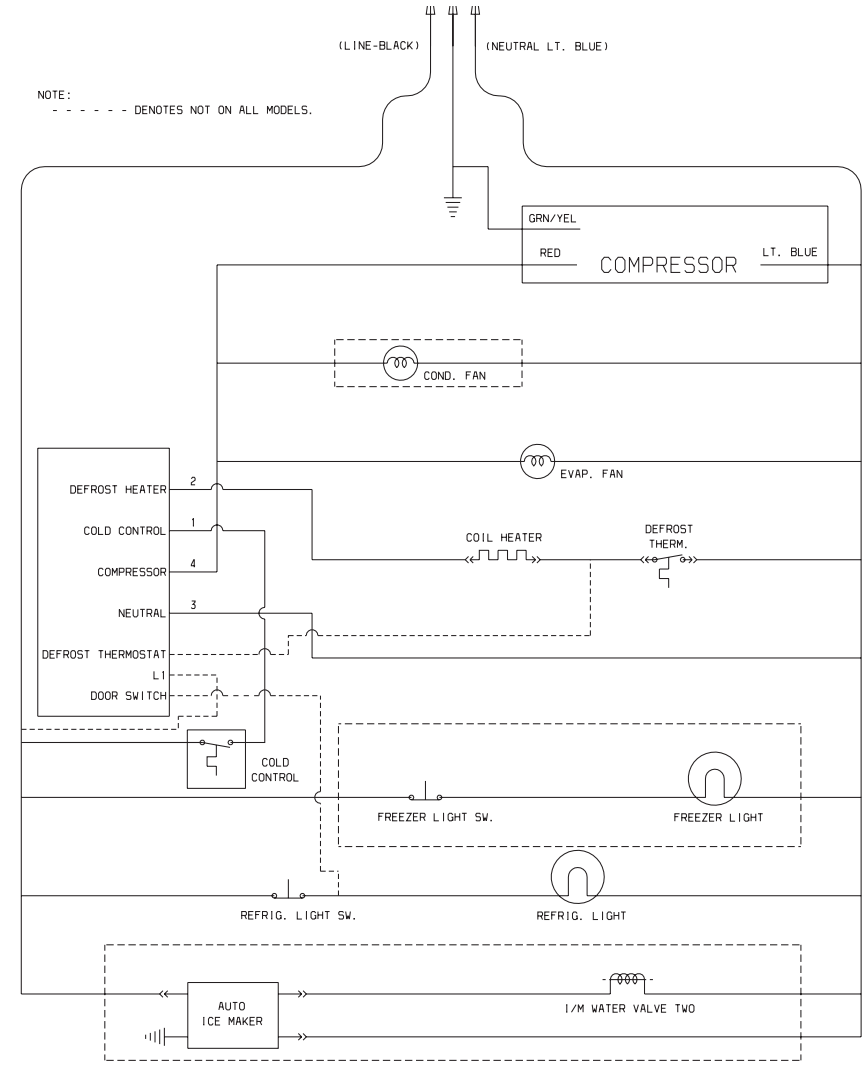

NOTE: ----- DENOTES NOT ON ALL MODELS.

SERVICE PARTS	15 & 17 CUBIC FOOT			18 CUBIC FOOT			21 CUBIC FOOT		
	STATIC	DYNAMIC	E-STAR	STATIC	DYNAMIC	E-STAR	DYNAMIC	E-STAR	
Compressor / Kit *	5303918264	5303918264	5303918299	5303918297	5303918297	5303918299	5303918297	5303918299	
Starter/PTC/TSD *	218721120	218721120	241527802	N/A	N/A	241527802	N/A	241527802	
Run Capacitor *	218909913	218909913	218909915	N/A	N/A	218909915	N/A	218909915	
Relay	N/A	N/A	N/A	5304433579	5304433579	N/A	5304433579	N/A	
Overload	N/A	N/A	N/A	5304433578	5304433578	N/A	5304433578	N/A	
Temperature Control	5304421256	5304421256	5304421256	5304421256	5304421256	5304421256	5304421256	5304421256	
Timer (if applicable)	215846606	215846606	215846606	215846606	215846606	215846606	215846606	215846606	
ADC (if applicable)	N/A	N/A	N/A	N/A	N/A	N/A	N/A	N/A	
Defrost Heater Kit	5303918203	5303918203	5303918203	5303918208	5303918208	5303918208	5303918247	5303918247	
Defrost Thermostat Kit	5303918202	5303918202	5303918202	5303918202	5303918202	5303918202	5303918202	5303918202	
Evaporator Fan Motor	240369701	240369701	240369701	240369701	240369701	241537301	240369701	240369701	
Condenser Fan Motor	N/A	240523601	240523601	N/A	240523601	240523601	240523601	241538001	

\* Typical compressor kit includes compressor, electrical components, and filter-drier

PERFORMANCE DATA NO LOAD AND NO DOOR OPENINGS AT MID-POINT CONTROL SETTING		
Capacitor Run or Induction Run	65°F (18°C) Ambient	90°F (32°C) Ambient
Operating Time	25 to 35%	45 to 55%
Freezer Temperature	2° to 8°F -17° to -13°C	0° to 5°F -18° to -15°C
Refrigerature Temperature	35° to 40°F 2° to 4°C	35° to 40°F 2° to 4°C
Low Side Pressure (cut-in)	8 to 16 psig 55 to 110 kPa	8 to 16 psig 55 to 110 kPa
Low Side Pressure (cut-out)	1 to 4 psig 7 to 28 kPa	1 to 4 psig 7 to 28 kPa
High Side Pressure (Last 1/3 of cycle)	110 to 120 psig 758 to 827 kPa	150 to 175 psig 1034 to 1207 kPa
Wattage (Last 1/3 of cycle)	140 to 185	140 to 185
Amps (Running)	1.1 to 1.6	1.1 to 1.6
Base Voltage	115 VAC (127 VAC Max)	115 VAC (127 VAC Max)

DEFROST SPECIFICATIONS				
Cabinet Size	Thermostat		Heater	
	Cut-in	Cut-out	Watts	Ohms
18' & 21'	25°F -4°C	47°F 8°C	375	35
14', 15' & 17'	25°F -4°C	47°F 8°C	325	41

Mechanical Timer - Defrost 30 Minutes Every 10 Hours of Compressor Run Time  
Electronic Timer (ADC) Defrost Up To 24 Minutes Every 6 - 72 Hours of Compressor Run Time

CONDENSER FAN MOTOR		
Watts	RPM	Amps
2.3	1100 CW Opposite Shaft	.15 Running

ICE MAKER SPECIFICATIONS		
Electrical	115 VAC (127 VAC Max)	60 Hertz
Thermostat	Opens at 48°F (9°C)	Closes at 15°F (-9°C)
Heater Wattage	165	

ICE MAKER CONNECTOR PLUG CONNECTIONS		
Wire Number	Wire Color	Connects to:
1	Green/Yellow	Ground
2	Yellow	Water Valve
3	Black	Line
4	Lt. Blue	Neutral

## SERVICE DATA SHEET

STANDARD - AUTOMATIC  
DEFROST TOP FREEZER MODELS (R134a) **P/N: 240379015**

### IMPORTANT SAFETY NOTICE

The information provided herein is designed to assist qualified repair personnel only. Untrained persons should not attempt to make repairs due to the possibility of electrical shock. Disconnect power cord before servicing.

### IMPORTANT

If any green grounding wires are moved during servicing, they must be returned to their original position and properly secured.

**CAUTION: All electrical parts and wiring must be shielded from torch flame. Do not allow torch to contact insulation; it will char at 200°F and flash ignite (burn) at 500°F. Excessive heat will distort the plastic liner.**

**NOTE: Some products come equipped with an Electronic Defrost Control. To initiate defrost, depress the fresh food light switch 5 times in 6 seconds (light bulb must be working). To terminate defrost, depress the fresh food light switch 5 times in 6 seconds.**

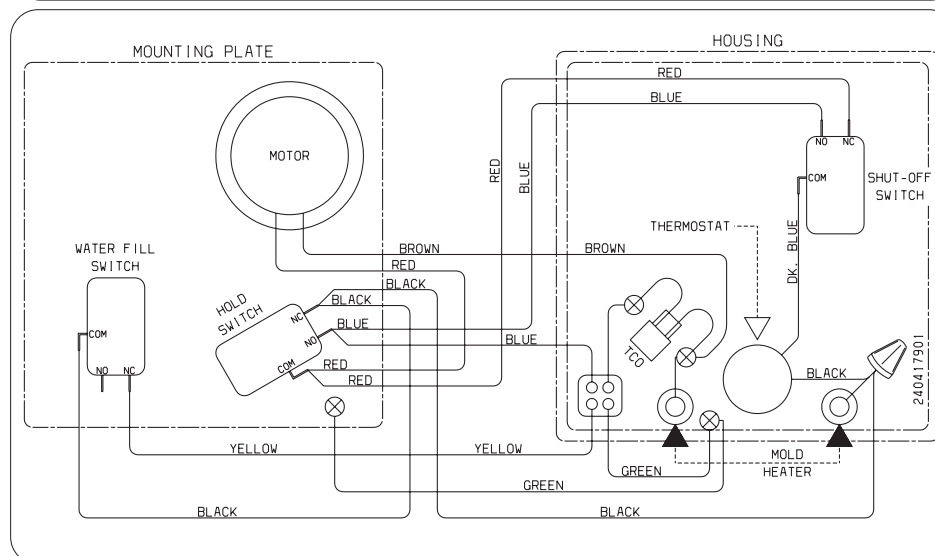

## ICE MAKER INFORMATION

### Test Cycling

Remove cover by inserting screwdriver in notch at bottom and prying cover from housing. Use screwdriver to rotate motor gear counterclockwise until *Holding Switch* circuit is completed. All components of ice maker should function to complete the cycle.

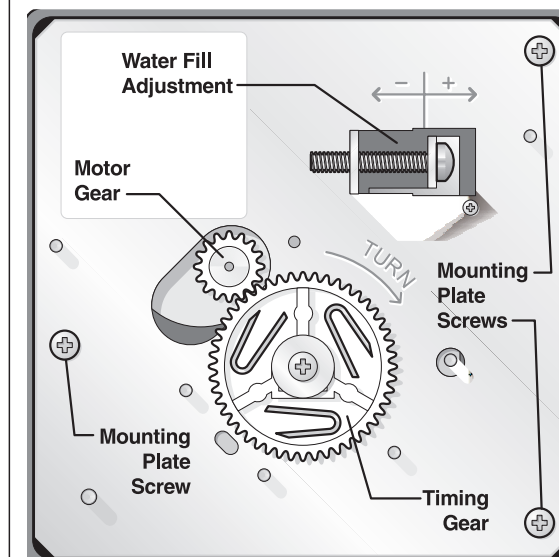

### Water Fill Volume

The water fill adjustment screw will change the fill time. One full turn is equal to 20cc (.68 oz.). The correct fill is 95 to 105cc (3.2 to 3.6 oz.). When a water valve is replaced, the fill volume must be checked.

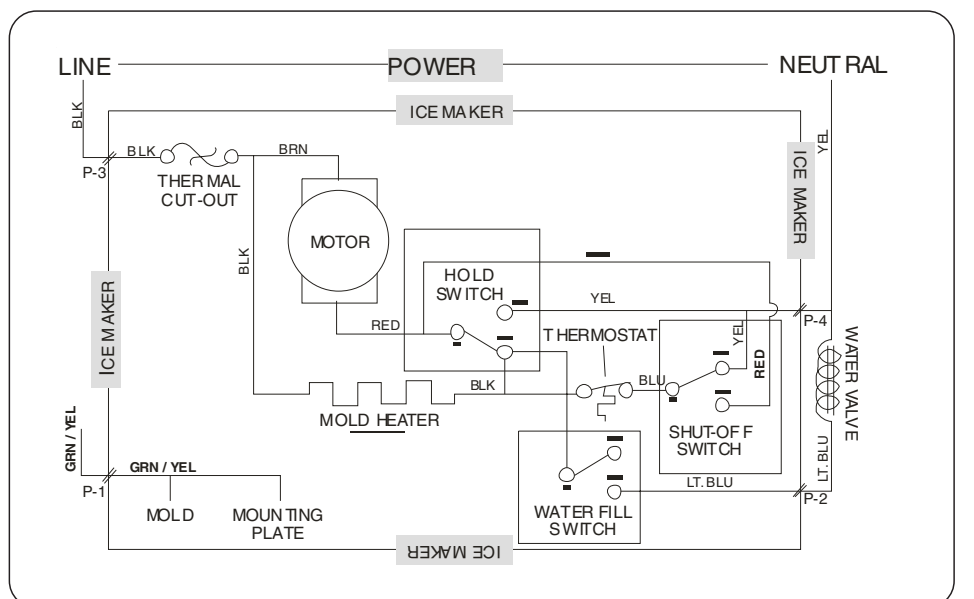

### Pictorial Schematic

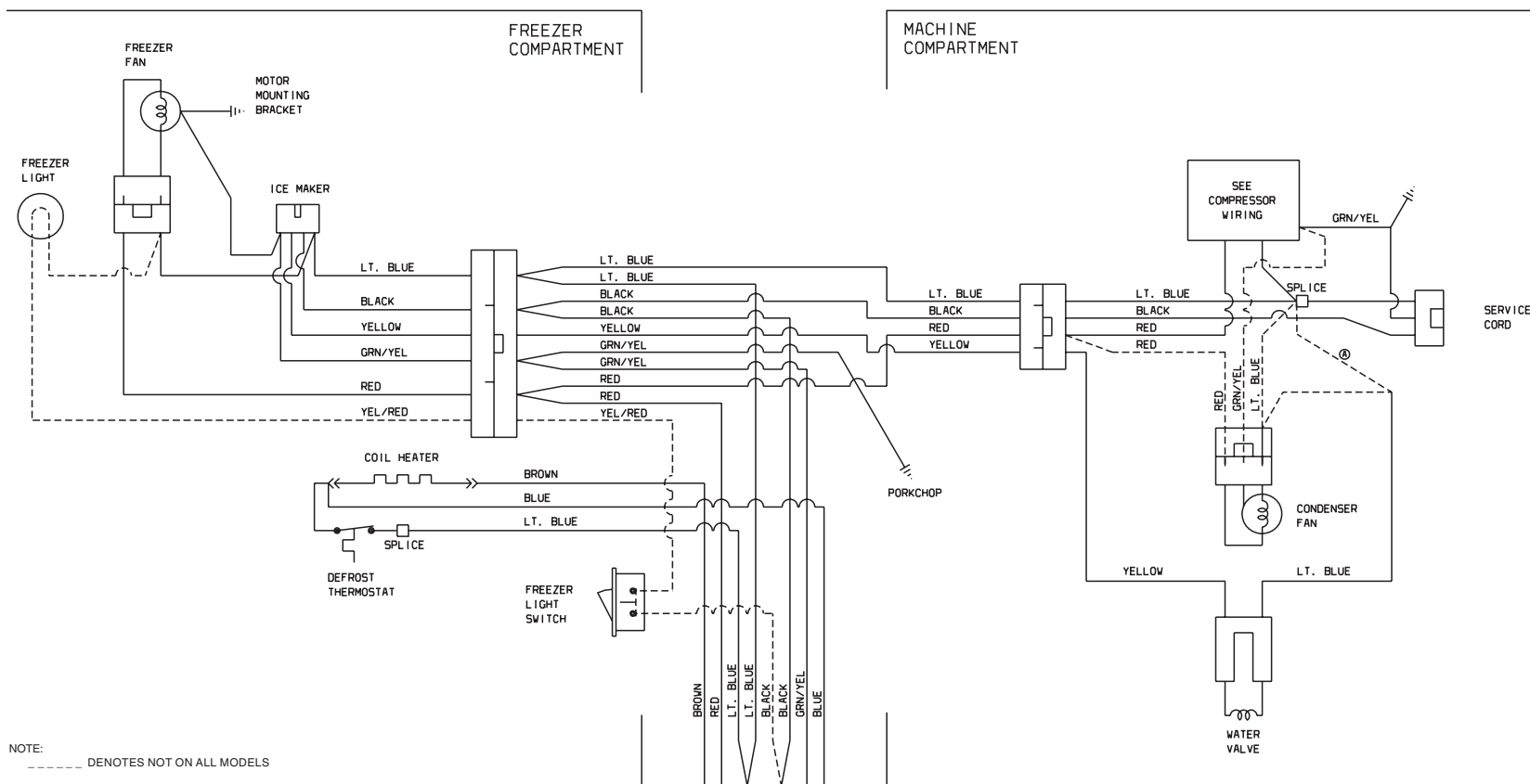

NOTE: - - - - DENOTES NOT ON ALL MODELS

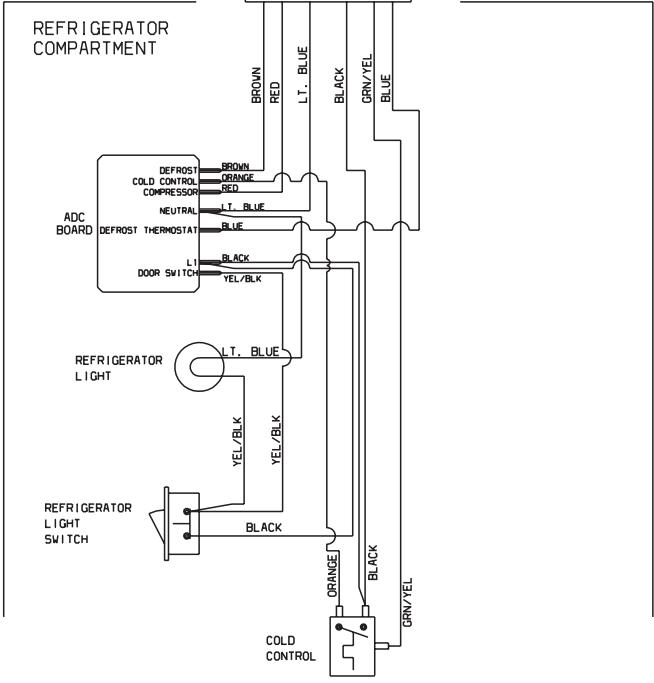
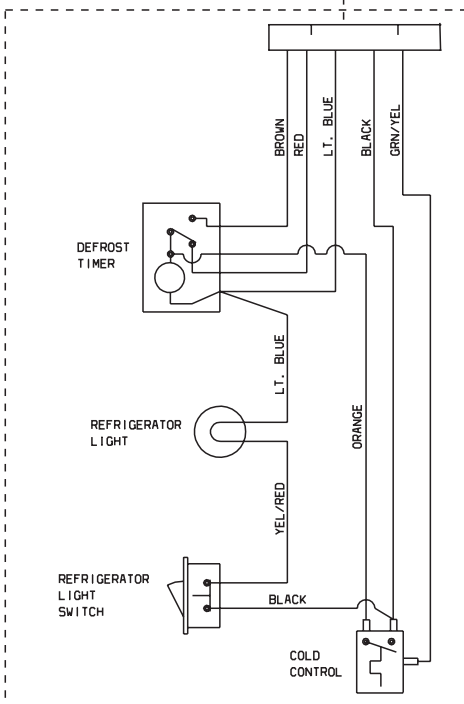

### COMPRESSOR WIRING

#### Induction Run Compressor with Relay

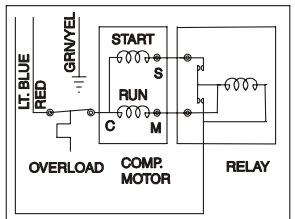

#### P.T.C. STARTER WITH RUN CAPACITOR

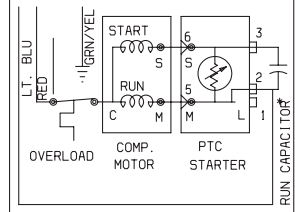

\* CAPACITOR IS ONLY USED WITH SOME P.T.C. MODELS.

### Ladder Schematic

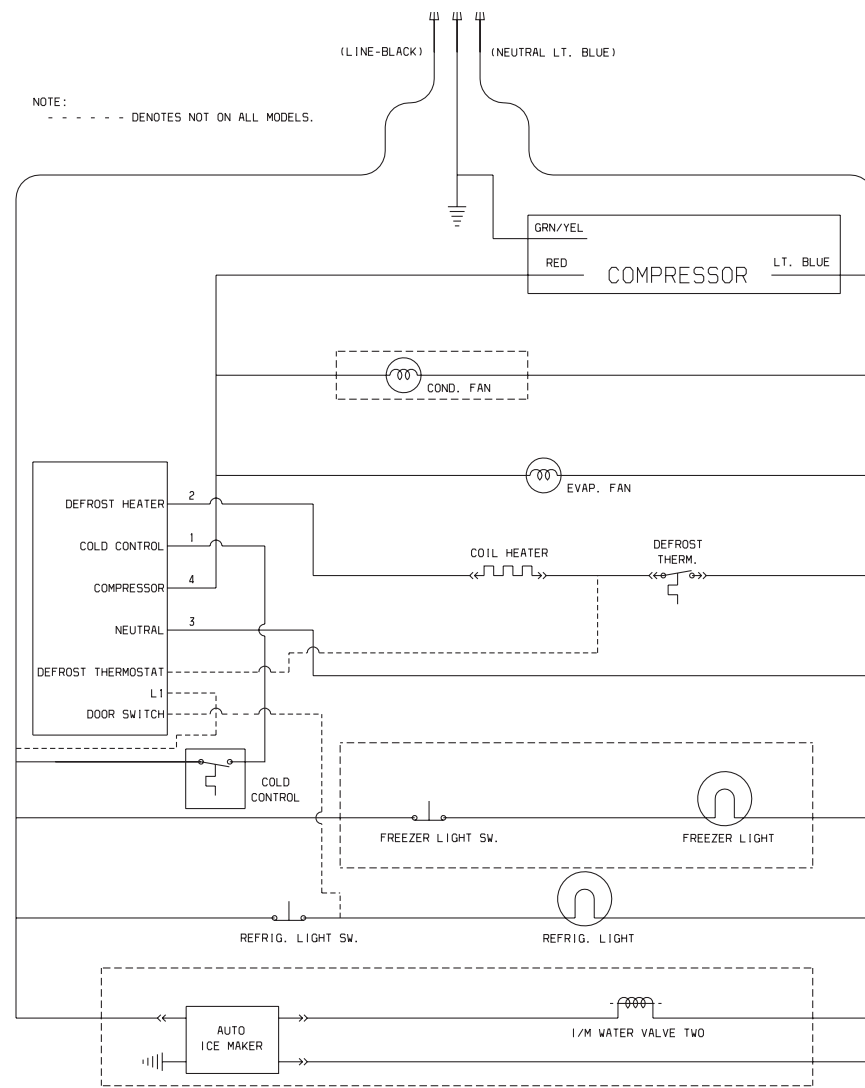

NOTE: - - - - DENOTES NOT ON ALL MODELS.

SERVICE PARTS	15 & 17 CUBIC FOOT			18 CUBIC FOOT			21 CUBIC FOOT	
	STATIC	DYNAMIC	E-STAR	STATIC	DYNAMIC	E-STAR	DYNAMIC	E-STAR
Compressor / Kit *	240550915	240550915	5303918299	240550915	240550915	5303918299	240550915	5303918299
Starter/PTC/TSD *	N/A	N/A	241527802	N/A	N/A	241527802	N/A	241527802
Run Capacitor *	N/A	N/A	218909915	N/A	N/A	218909915	N/A	218909915
Relay	5304433579	5304433579	N/A	5304433579	5304433579	N/A	5304433579	N/A
Overload	5304433578	5304433578	N/A	5304433578	5304433578	N/A	5304433578	N/A
Temperature Control	5304421256	5304421256	5304421256	5304421256	5304421256	5304421256	5304421256	5304421256
Timer (if applicable)	215846606	215846606	215846606	215846606	215846606	215846606	215846606	215846606
ADC (if applicable)	N/A	N/A	N/A	N/A	N/A	N/A	N/A	N/A
Defrost Heater Kit	5303918203	5303918203	5303918203	5303918208	5303918208	5303918208	5303918247	5303918247
Defrost Thermostat Kit	5303918202	5303918202	5303918202	5303918202	5303918202	5303918202	5303918202	5303918202
Evaporator Fan Motor	240369701	240369701	240369701	240369701	240369701	240369701	240369701	240369701
Condenser Fan Motor	N/A	240523601	240523601	N/A	240523601	240523601	240334001	240334001

\* Typical compressor kit includes compressor, electrical components, and filter-drier

PERFORMANCE DATA NO LOAD AND NO DOOR OPENINGS AT MID-POINT CONTROL SETTING		
Capacitor Run or Induction Run	65°F (18°C) Ambient	90°F (32°C) Ambient
Operating Time	25 to 35%	45 to 55%
Freezer Temperature	2° to 8°F -17° to -13°C	0° to 5°F -18° to -15°C
Refrigerature Temperature	35° to 40°F 2° to 4°C	35° to 40°F 2° to 4°C
Low Side Pressure (cut-in)	8 to 16 psig 55 to 110 kPa	8 to 16 psig 55 to 110 kPa
Low Side Pressure (cut-out)	1 to 4 psig 7 to 28 kPa	1 to 4 psig 7 to 28 kPa
High Side Pressure (Last 1/3 of cycle)	110 to 120 psig 758 to 827 kPa	150 to 175 psig 1034 to 1207 kPa
Wattage (Last 1/3 of cycle)	140 to 185	140 to 185
Amps (Running)	1.1 to 1.6	1.1 to 1.6
Base Voltage	115 VAC (127 VAC Max)	115 VAC (127 VAC Max)

DEFROST SPECIFICATIONS				
Cabinet Size	Thermostat		Heater	
	Cut-in	Cut-out	Watts	Ohms
18' & 21'	25°F -4°C	47°F 8°C	375	35
14', 15' & 17'	25°F -4°C	47°F 8°C	325	41

Mechanical Timer - Defrost 30 Minutes Every 10 Hours of Compressor Run Time  
Electronic Timer (ADC) Defrost Up To 24 Minutes Every 6 - 72 Hours of Compressor Run Time

CONDENSER FAN MOTOR		
Watts	RPM	Amps
2.3	1100 CW Opposite Shaft	.15 Running

ICE MAKER SPECIFICATIONS		
Electrical	115 VAC (127 VAC Max)	60 Hertz
Thermostat	Opens at 48°F (9°C)	Closes at 15°F (-9°C)
Heater Wattage	165	

ICE MAKER CONNECTOR PLUG CONNECTIONS		
Wire Number	Wire Color	Connects to:
1	Green/Yellow	Ground
2	Yellow	Water Valve
3	Black	Line
4	Lt. Blue	Neutral

## SERVICE DATA SHEET

STANDARD - AUTOMATIC  
DEFROST TOP FREEZER  
MODELS (R134a)

P/N: 241588200

### IMPORTANT SAFETY NOTICE

The information provided herein is designed to assist qualified repair personnel only. Untrained persons should not attempt to make repairs due to the possibility of electrical shock. Disconnect power cord before servicing.

### IMPORTANT

If any green grounding wires are moved during servicing, they must be returned to their original position and properly secured.

**CAUTION: All electrical parts and wiring must be shielded from torch flame. Do not allow torch to contact insulation; it will char at 200°F and flash ignite (burn) at 500°F. Excessive heat will distort the plastic liner.**

**NOTE: Some products come equipped with an Electronic Defrost Control. To initiate defrost, depress the fresh food light switch 5 times in 6 seconds (light bulb must be working). To terminate defrost, depress the fresh food light switch 5 times in 6 seconds.**

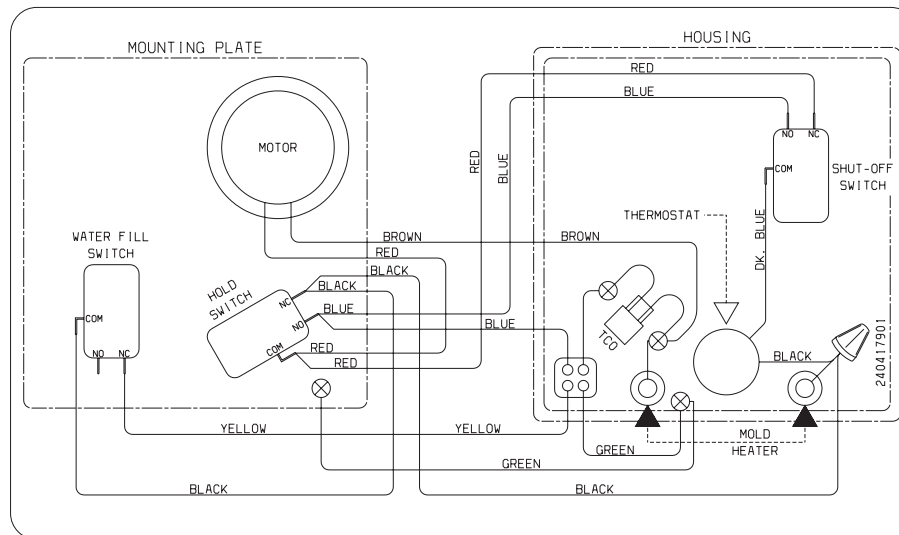

## ICE MAKER INFORMATION

### Test Cycling

Remove cover by inserting screwdriver in notch at bottom and prying cover from housing. Use screwdriver to rotate motor gear counterclockwise until *Holding Switch* circuit is completed. All components of ice maker should function to complete the cycle.

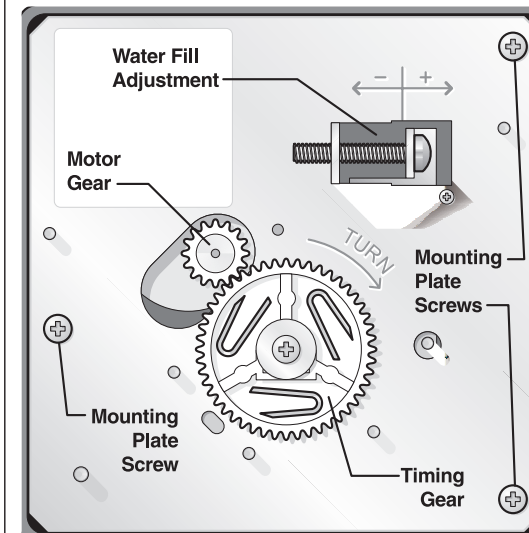

### Water Fill Volume

The water fill adjustment screw will change the fill time. One full turn is equal to 20cc (.68 oz.). The correct fill is 95 to 105cc (3.2 to 3.6 oz.). When a water valve is replaced, the fill volume must be checked.

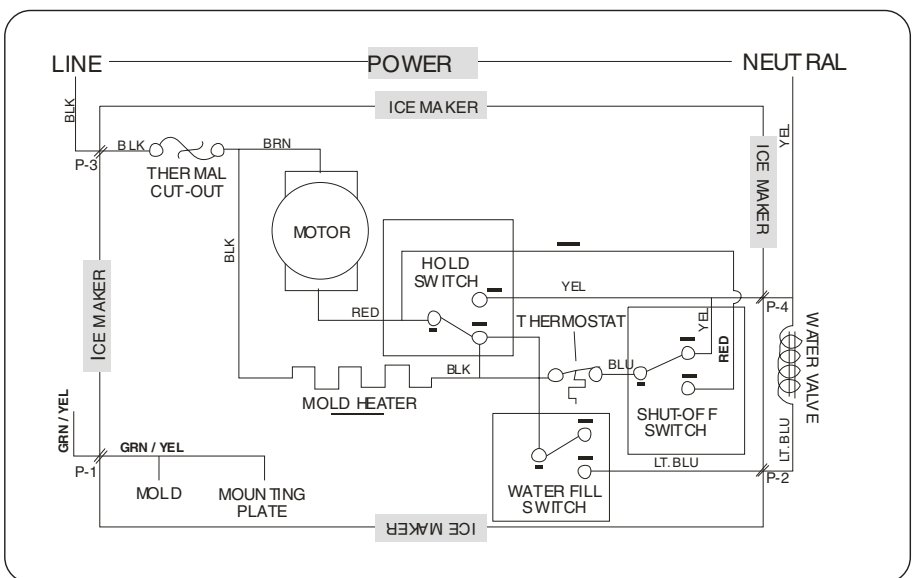

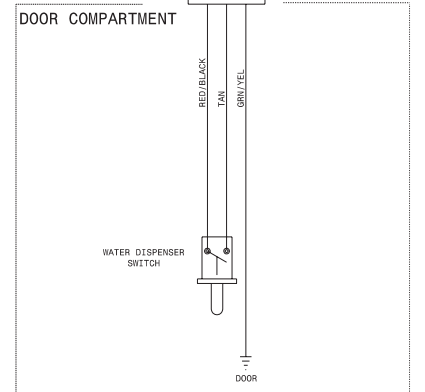
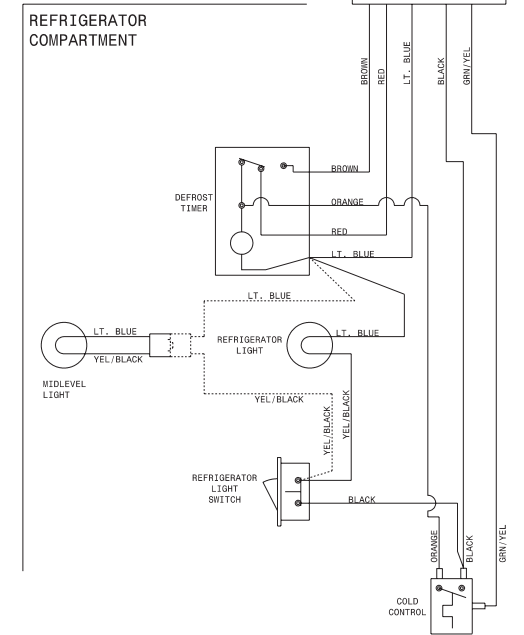
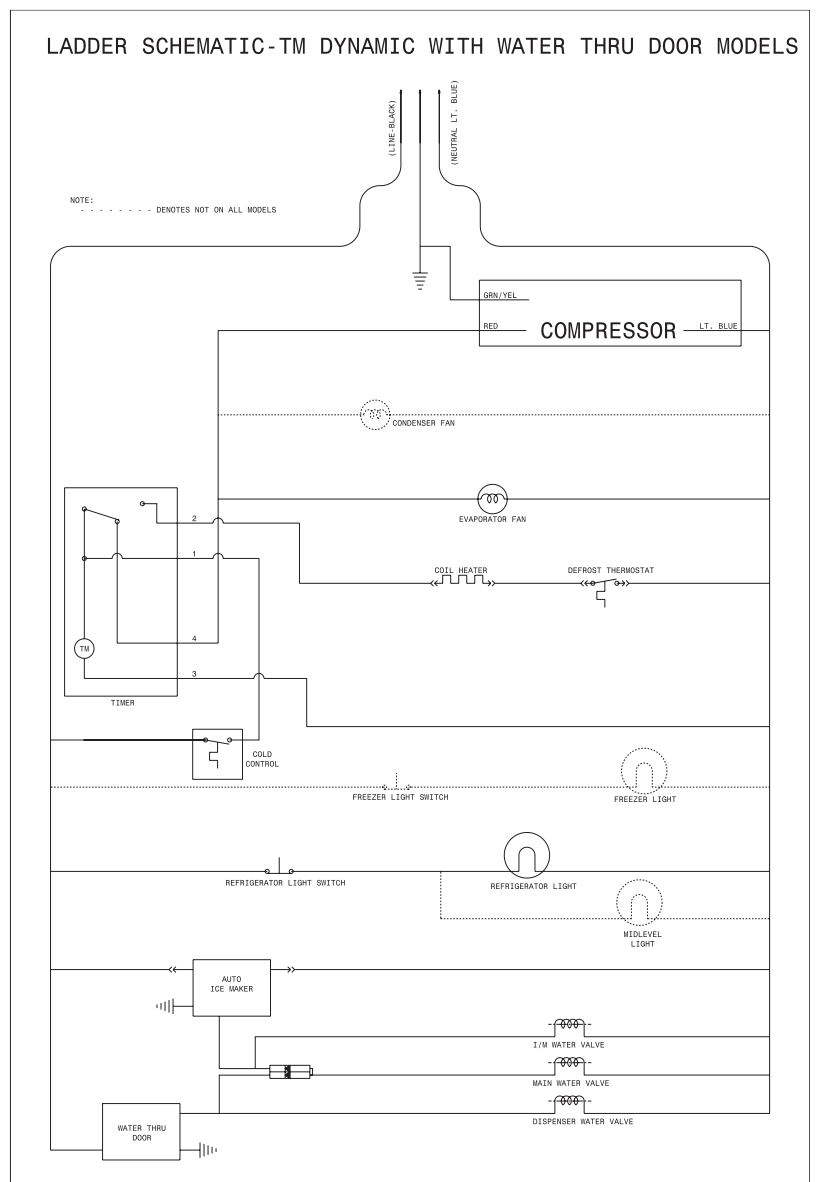
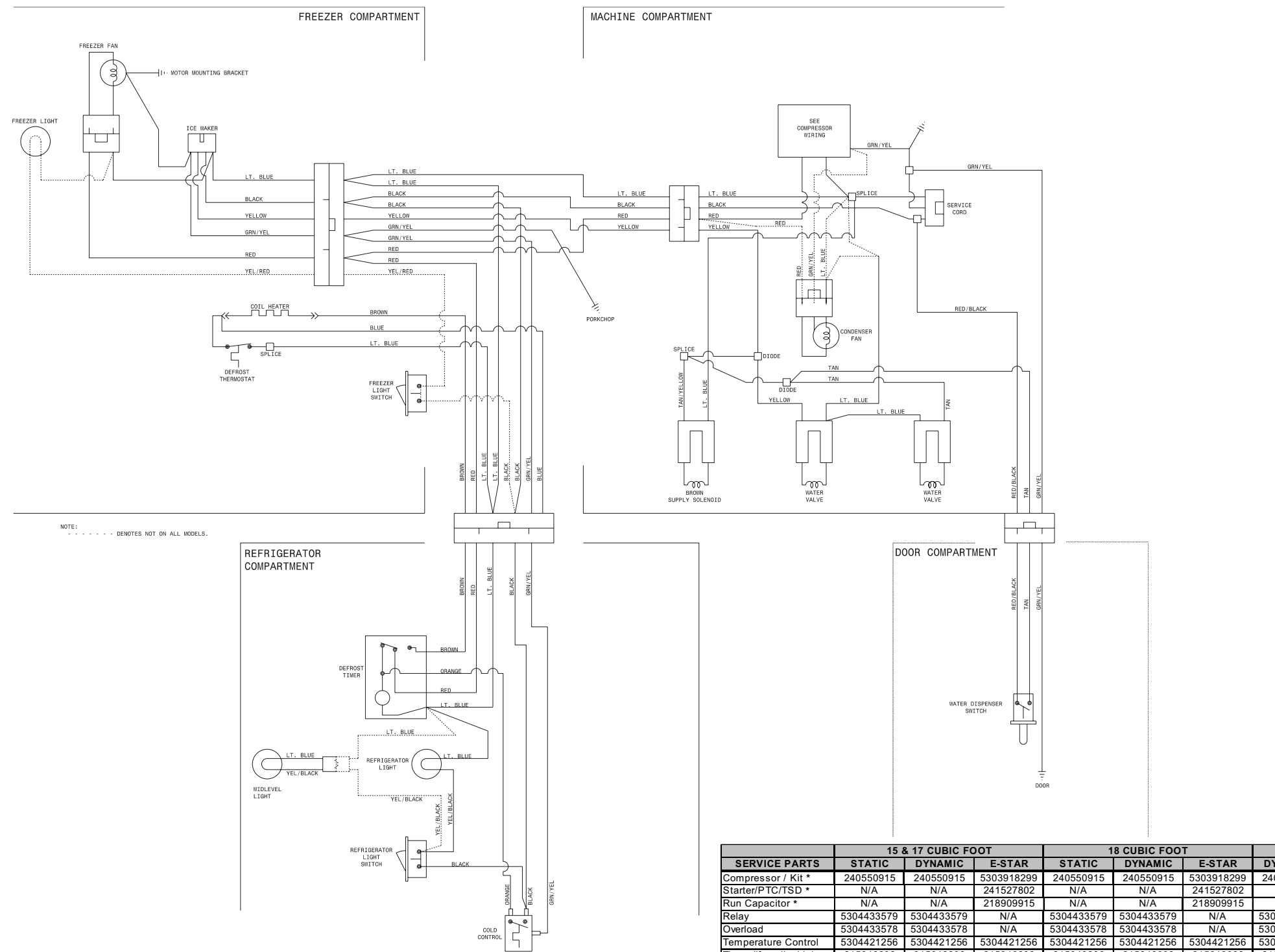

SERVICE PARTS	15 & 17 CUBIC FOOT			18 CUBIC FOOT			21 CUBIC FOOT	
	STATIC	DYNAMIC	E-STAR	STATIC	DYNAMIC	E-STAR	DYNAMIC	E-STAR
Compressor / Kit *	240550915	240550915	5303918299	240550915	240550915	5303918299	240550915	5303918299
Starter/PTC/TSD *	N/A	N/A	241527802	N/A	N/A	241527802	N/A	241527802
Run Capacitor *	N/A	N/A	218909915	N/A	N/A	218909915	N/A	218909915
Relay	5304433579	5304433579	N/A	5304433579	5304433579	N/A	5304433579	N/A
Overload	5304433578	5304433578	N/A	5304433578	5304433578	N/A	5304433578	N/A
Temperature Control	5304421256	5304421256	5304421256	5304421256	5304421256	5304421256	5304421256	5304421256
Timer (if applicable)	215846606	215846606	215846606	215846606	215846606	215846606	215846606	215846606
ADC (if applicable)	N/A	N/A	N/A	N/A	N/A	N/A	N/A	N/A
Defrost Heater Kit	5303918203	5303918203	5303918203	5303918208	5303918208	5303918208	5303918247	5303918247
Defrost Thermostat Kit	5303918202	5303918202	5303918202	5303918202	5303918202	5303918202	5303918202	5303918202
Evaporator Fan Motor	240369701	240369701	240369701	240369701	240369701	240369701	240369701	240369701
Condenser Fan Motor	N/A	240523601	240523601	N/A	240523601	240523601	240334001	240334001

\* Typical compressor kit includes compressor, electrical components, and filter-drier

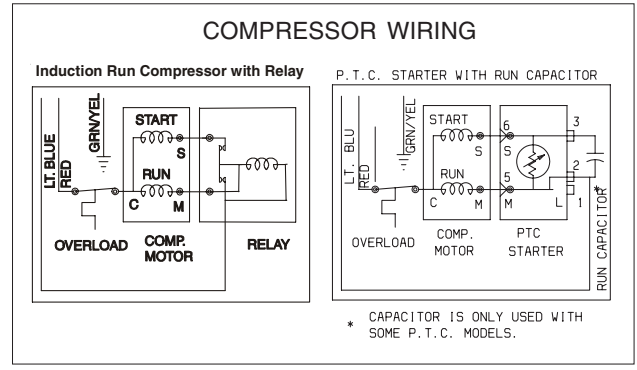



PERFORMANCE DATA NO LOAD AND NO DOOR OPENINGS AT MID-POINT CONTROL SETTING				
Type A With Run/Start Capacitor	65°F (18°C) Ambient	90°F (32°C) Ambient		
Operating Time	32 to 40%	55 to 65%		
Freezer Temperature	0° to 4°F -18° to -16°C	-1° to 3°F -18° to -16°C		
Refrigerator Temperature	34° to 39°F 1° to 4°C	34° to 39°F 1° to 4°C		
Low Side Pressure (cut-in)	5 to 12 psig 34 to 83 kPa	5 to 12 psig 34 to 83 kPa		
Low Side Pressure (cut-out)	-2 to 2 psig -14 to 14 kPa	-2 to 2 psig -14 to 14 kPa		
High Side Pressure (Last 1/3 of cycle)	90 to 115 psig 621 to 793 kPa	130 to 155 psig 896 to 1069 kPa		
Wattage (Last 1/3 of cycle)	120 to 150	130 to 160		
Amps (Running)	1.2 to 1.5	1.2 to 1.5		
Base Voltage	115 vac (127 vac max)	115 vac (127 vac max)		
DEFROST SPECIFICATIONS				
Cabinet Size	Thermostat		Heater	
	Cut-in	Cut-out	Watts	Ohms
23' & 26'	25°F -4°C	47°F 8°C	450	30
Electronic Timer - (ADC) Defrost 24 minutes every 6 to 72 hours of compressor run time.				
CONDENSER FAN MOTOR				
Watts	RPM	Amps		
7	1100 CW Opposite Shaft	.1 Running		
ICE MAKER SPECIFICATIONS				
Electrical	115 vac (127 vac max)	60 Hertz		
Thermostat	Opens at 48°F (9°C)	Closes at 15°F (-9°C)		
Heater Wattage	165			

ICE MAKER CONNECTOR PLUG CONNECTIONS		
Wire Number	Wire Color	Connects to:
1	Green/Yellow	Ground
2	Yellow	Water Valve
3	Black	Line
4	Lt. Blue	Neutral

## SERVICE DATA SHEET - 240389613

### R134a

### ICE & WATER - AUTOMATIC DEFROST SIDE BY SIDE MODELS

#### IMPORTANT SAFETY NOTICE

The information provided herein is designed to assist qualified repair personnel only. Untrained persons should not attempt to make repairs due to the possibility of electrical shock. Disconnect power cord before servicing.

#### IMPORTANT

If any green grounding wires are moved during servicing, they must be returned to their original position and properly secured.

**CAUTION: All electrical parts and wiring must be shielded from torch flame. Do not allow torch to contact insulation; it will char at 200°F and flash ignite (burn) at 500°F. Excessive heat will distort the plastic liner.**

**NOTE:** This product comes equipped with an Electronic Defrost Control. To initiate defrost, depress the fresh food light switch 5 times in 6 seconds (light bulb must be working). To terminate defrost, depress the fresh food light switch 5 times in 6 seconds.

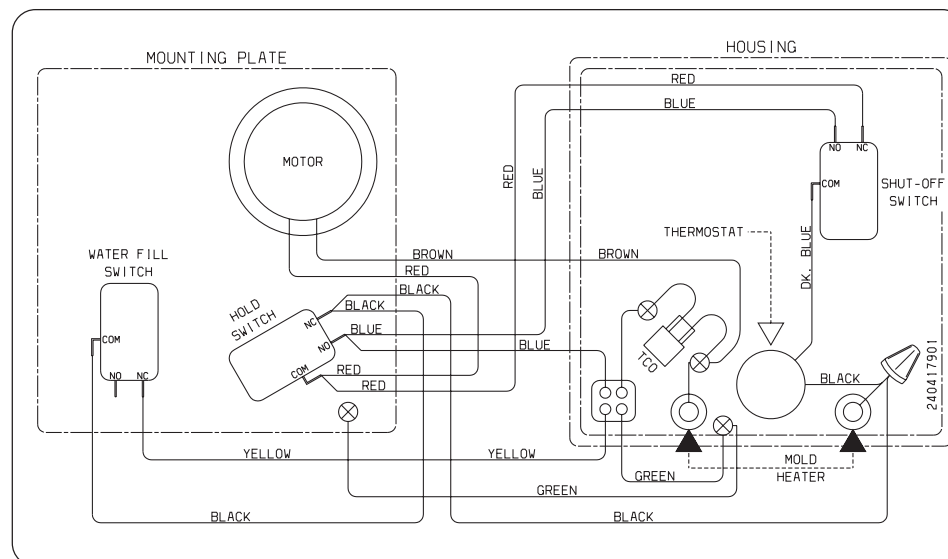

## ICE MAKER INFORMATION

### Test Cycling

Remove cover by inserting screwdriver in notch at bottom and prying cover from housing. Use screwdriver to rotate motor gear counterclockwise until holding switch circuit is completed. All components of ice maker should function to complete the cycle.

### Water Fill Volume

The water fill adjustment screw will change the fill time. One full turn is equal to 20cc (.68 oz.). The correct fill is 102 to 130cc (3.4 to 4.3 oz.). When a water valve is replaced, the fill volume must be checked.

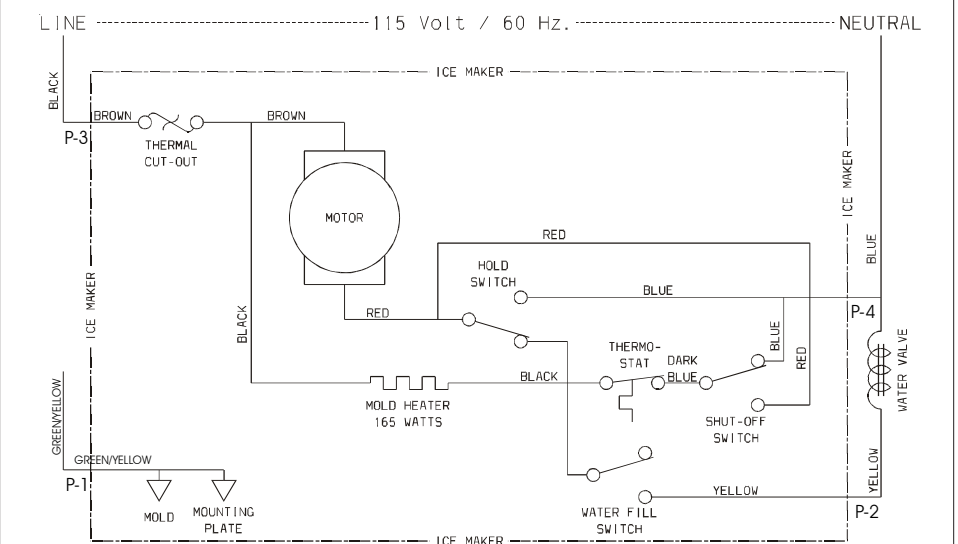
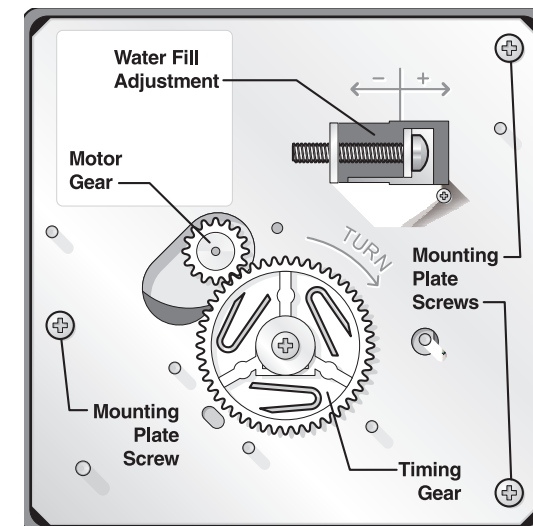

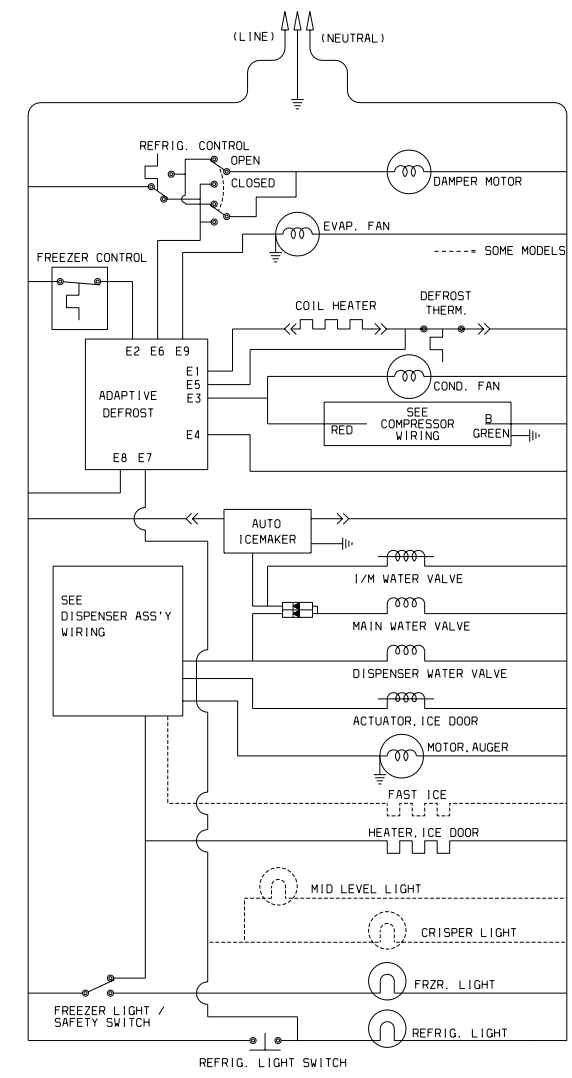
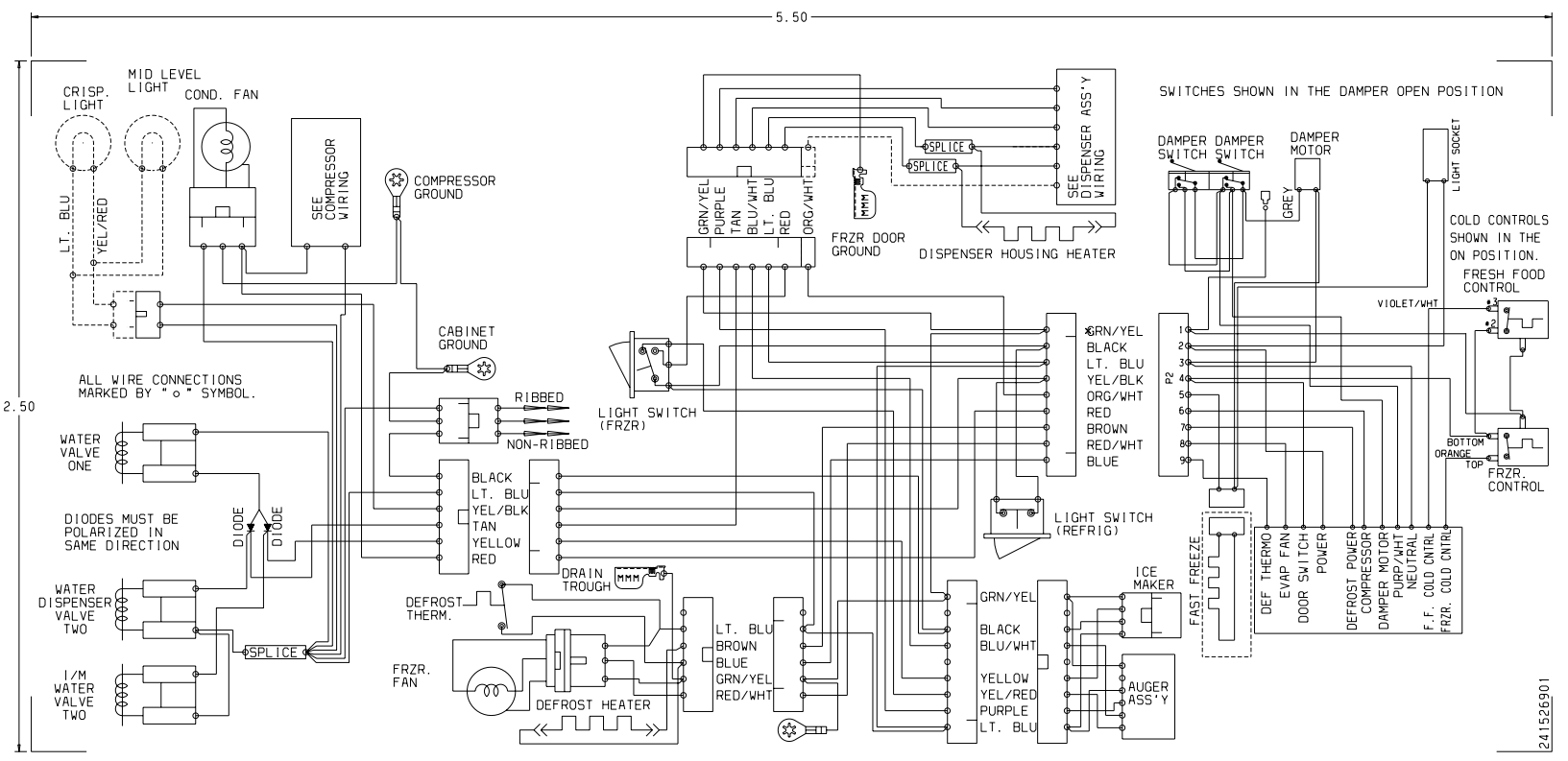

ELECTRONIC DISPENSER

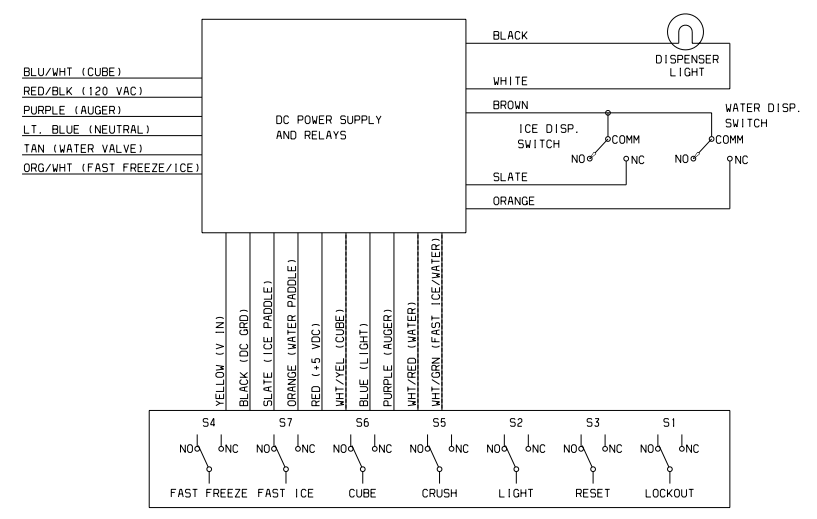

ELECTRO-MECHANICAL DISPENSER

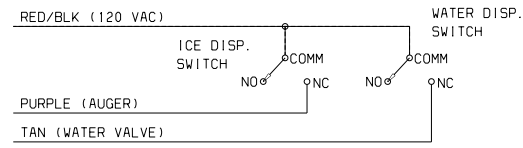

P. T. C. STARTER WITH RUN CAPACITOR

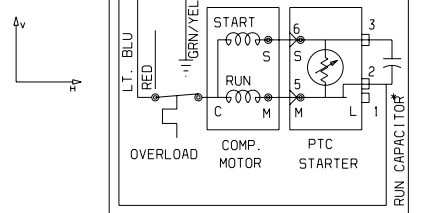

\* CAPACITOR IS ONLY USED WITH SOME P. T. C. MODELS.

SERVICE PARTS	23 CUBIC FOOT		26 CUBIC FOOT	
	STANDARD	E-STAR	STANDARD	E-STAR
Compressor Kit *	5303918251	5303918251	5303918254	5303918254
Starter/PTC *	218721119	218721119	218721119	218721119
Run Capacitor *	216787800	216787800	218909901	218909901
Temp. Control-Refr	241507701	241507701	241507701	241507701
Temp. Control-Frizr	450226-07	450226-07	450226-07	450226-07
Timer (if applicable)	N/A	N/A	N/A	N/A
ADC (if applicable)	241508001	241508001	241508001	241508001
Defrost Heater Kit	5303918253	5303918253	5303918253	5303918253
Defrost Thermostat Kit	5303918214	5303918214	5303918214	5303918214
Evaporator Fan Motor	240315803	240315802	240315803	240315802
Condenser Fan Motor	240397101	240334001	240397101	240334002

\* Typical compressor kit includes compressor, electrical components, and filter-drier

PERFORMANCE DATA NO LOAD AND NO DOOR OPENINGS AT MID-POINT CONTROL SETTING				
Type A With Run/Start Capacitor	65°F (18°C) Ambient	90°F (32°C) Ambient		
Operating Time	32 to 40%	55 to 65%		
Freezer Temperature	0° to 4°F -18° to -16°C	-1° to 3°F -18° to -16°C		
Refrigerator Temperature	34° to 39°F 1° to 4°C	34° to 39°F 1° to 4°C		
Low Side Pressure (cut-in)	5 to 12 psig 34 to 83 kPa	5 to 12 psig 34 to 83 kPa		
Low Side Pressure (cut-out)	-2 to 2 psig -14 to 14 kPa	-2 to 2 psig -14 to 14 kPa		
High Side Pressure (Last 1/3 of cycle)	90 to 115 psig 621 to 793 kPa	130 to 155 psig 896 to 1069 kPa		
Wattage (Last 1/3 of cycle)	120 to 150	130 to 160		
Amps (Running)	1.2 to 1.5	1.2 to 1.5		
Base Voltage	115 vac (127 vac max)	115 vac (127 vac max)		
DEFROST SPECIFICATIONS				
Cabinet Size	Thermostat		Heater	
	Cut-in	Cut-out	Watts	Ohms
23' & 26'	25°F -4°C	47°F 8°C	450	30
Electronic Timer - (ADC) Defrost 24 minutes every 6 to 72 hours of compressor run time.				
CONDENSER FAN MOTOR				
Watts	RPM	Amps		
7	1100 CW Opposite Shaft	.1 Running		
ICE MAKER SPECIFICATIONS				
Electrical	115 vac (127 vac max)	60 Hertz		
Thermostat	Opens at 48°F (9°C)	Closes at 15°F (-9°C)		
Heater Wattage	165			

ICE MAKER CONNECTOR PLUG CONNECTIONS		
Wire Number	Wire Color	Connects to:
1	Green/Yellow	Ground
2	Yellow	Water Valve
3	Black	Line
4	Lt. Blue	Neutral

## SERVICE DATA SHEET - 240389615

### R134a ICE & WATER - AUTOMATIC DEFROST SIDE BY SIDE MODELS

#### IMPORTANT SAFETY NOTICE

The information provided herein is designed to assist qualified repair personnel only. Untrained persons should not attempt to make repairs due to the possibility of electrical shock. Disconnect power cord before servicing.

#### IMPORTANT

If any green grounding wires are moved during servicing, they must be returned to their original position and properly secured.

**CAUTION: All electrical parts and wiring must be shielded from torch flame. Do not allow torch to contact insulation; it will char at 200°F and flash ignite (burn) at 500°F. Excessive heat will distort the plastic liner.**

**NOTE: This product comes equipped with an Electronic Defrost Control. To initiate defrost, depress the fresh food light switch 5 times in 6 seconds (light bulb must be working). To terminate defrost, depress the fresh food light switch 5 times in 6 seconds.**

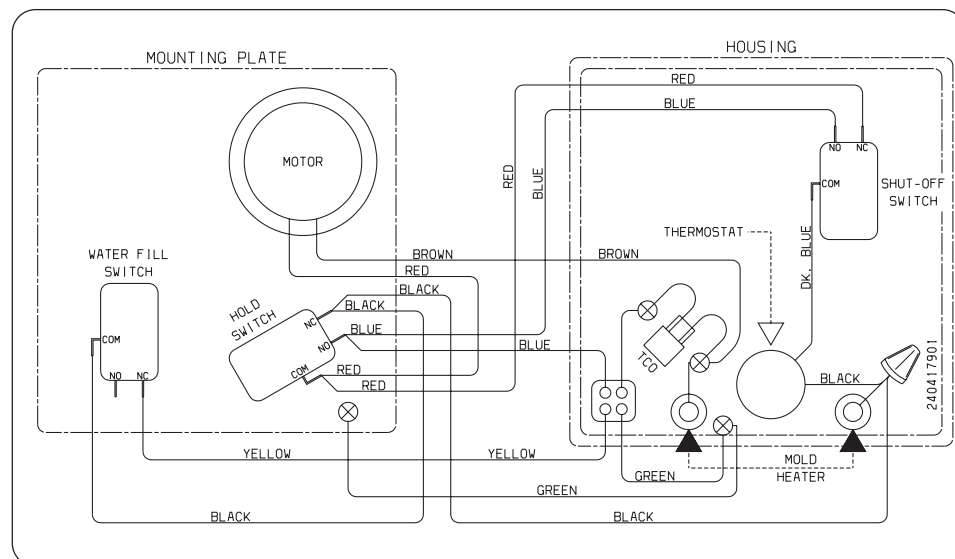

## ICE MAKER INFORMATION

### Test Cycling

Remove cover by inserting screwdriver in notch at bottom and prying cover from housing. Use screwdriver to rotate motor gear counterclockwise until holding switch circuit is completed. All components of ice maker should function to complete the cycle.

### Water Fill Volume

The water fill adjustment screw will change the fill time. One full turn is equal to 20cc (.68 oz.). The correct fill is 102 to 130cc (3.4 to 4.3 oz.). When a water valve is replaced, the fill volume must be checked.

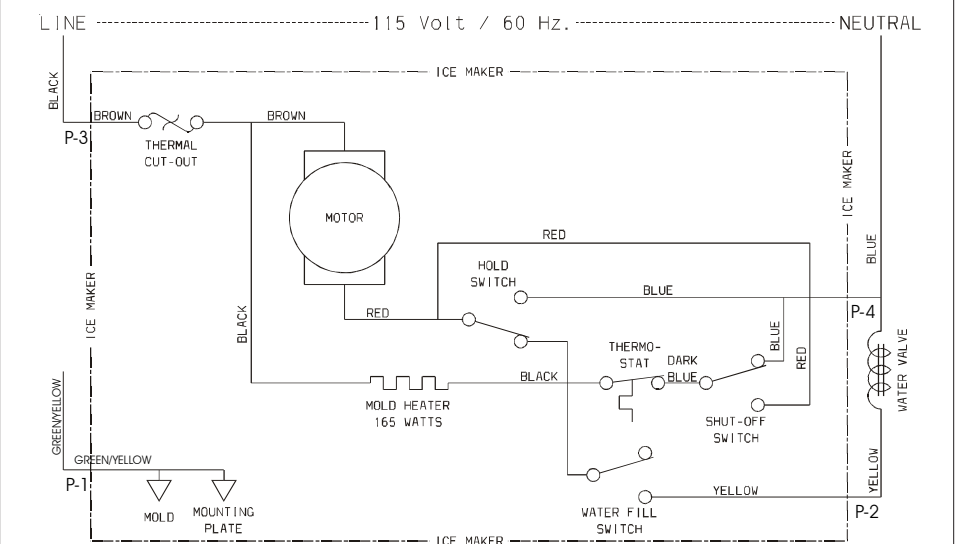
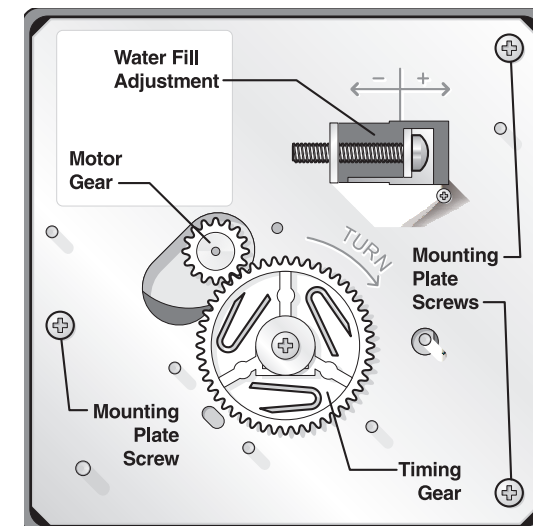



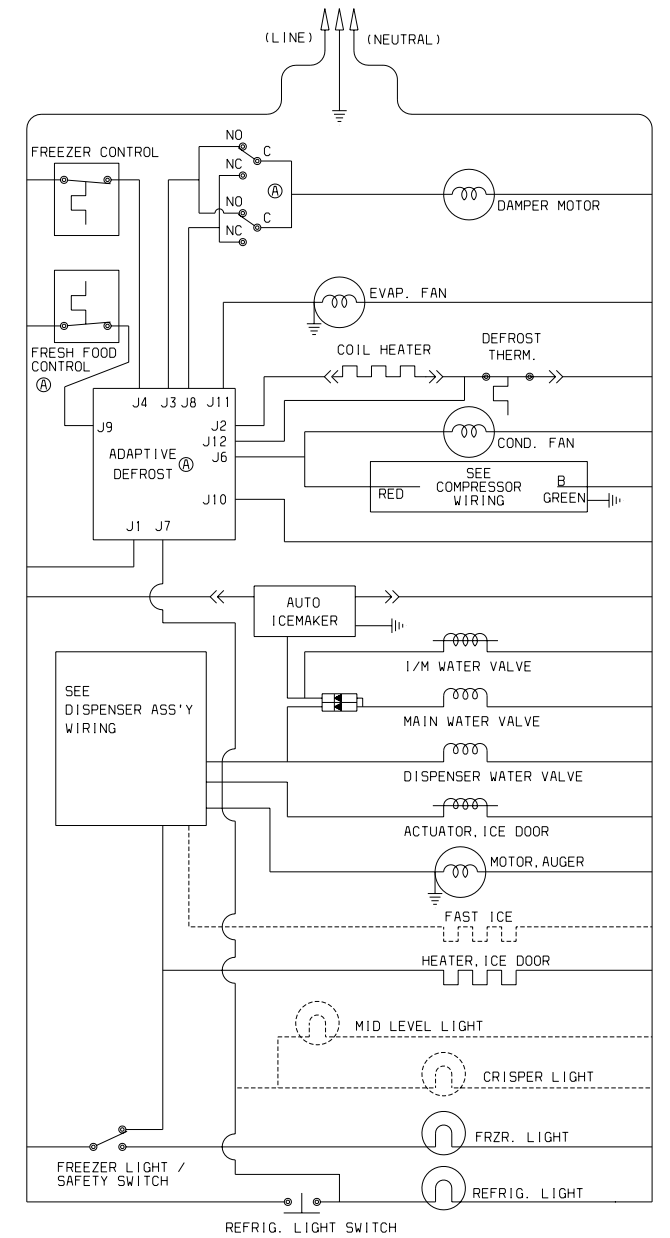
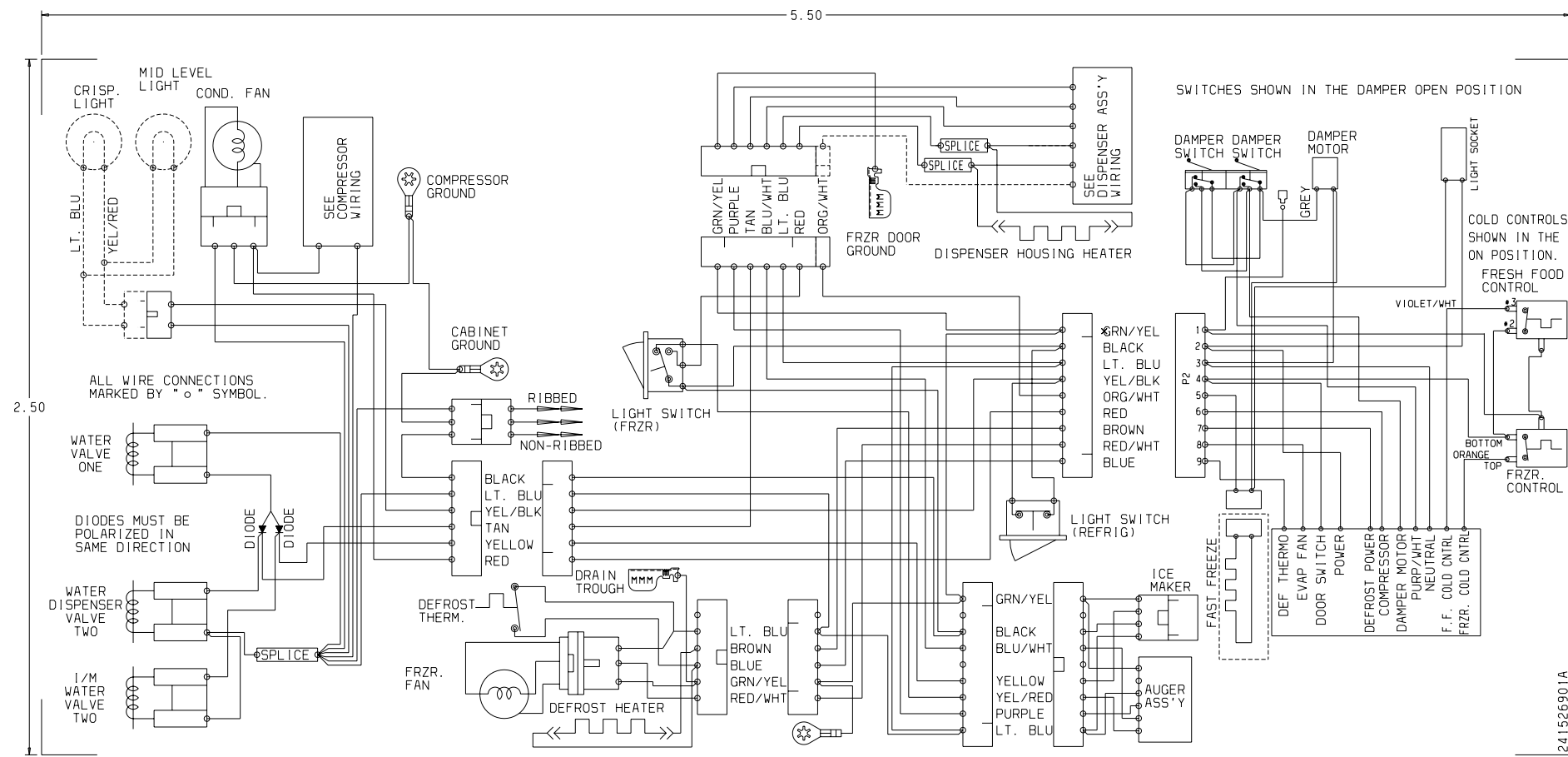

ELECTRONIC DISPENSER

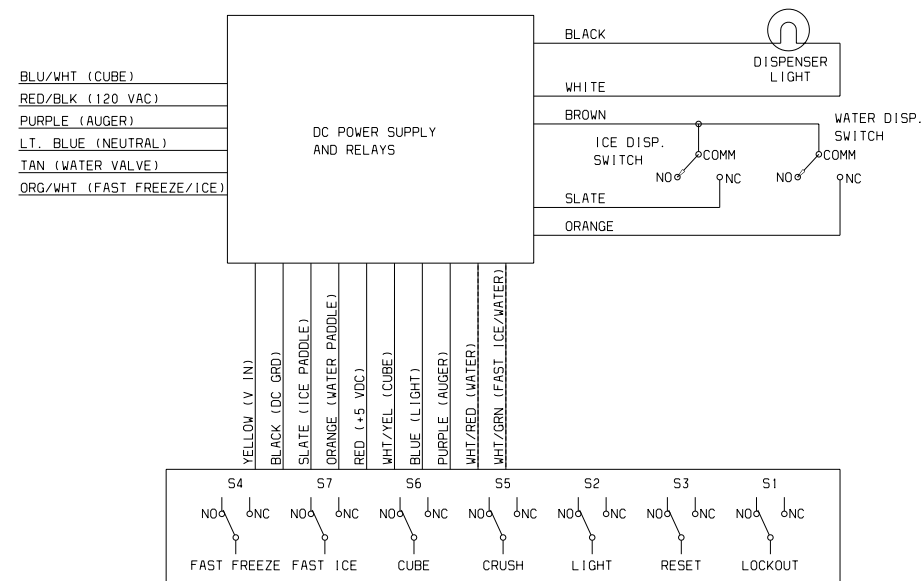

ELECTRO-MECHANICAL DISPENSER

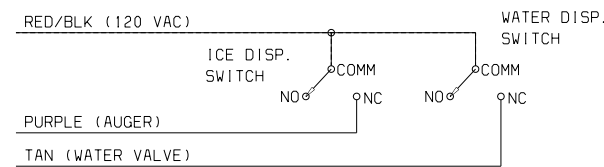

P. T. C. STARTER WITH RUN CAPACITOR

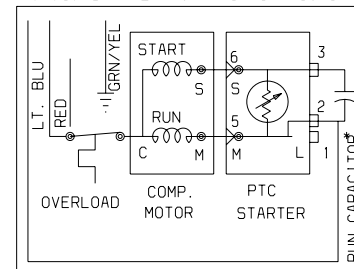

\* CAPACITOR IS ONLY USED WITH SOME P. T. C. MODELS.

SERVICE PARTS	23 CUBIC FOOT		26 CUBIC FOOT	
	STANDARD	E-STAR	STANDARD	E-STAR
Compressor Kit *	5303918251	5303918299	5303918254	5303918298
Starter/PTC/TSD *	218721119	241527802	218721119	241527801
Run Capacitor *	218909912	218909915	218909912	218909915
Temp. Control-Refr	241507701	241507701	241507701	241507701
Temp. Control-Frzer	450226-07	450226-07	450226-07	450226-07
Timer (if applicable)	N/A	N/A	N/A	N/A
ADC (if applicable)	241508001	241508001	241508001	241508001
Defrost Heater Kit	5303918253	5303918253	5303918253	5303918253
Defrost Thermostat Kit	5303918214	5303918214	5303918214	5303918214
Evaporator Fan Motor	240369701	240369701	240369701	241537301
Condenser Fan Motor	240397101	241538001	240397101	241538001

\* Typical compressor kit includes compressor, electrical components, and filter-drier

PERFORMANCE DATA NO LOAD AND NO DOOR OPENINGS AT MID-POINT CONTROL SETTING				
Type A With Run/Start Capacitor	65°F (18°C) Ambient	90°F (32°C) Ambient		
Operating Time	32 to 40%	55 to 65%		
Freezer Temperature	0° to 4°F -18° to -16°C	-1° to 3°F -18° to -16°C		
Refrigerator Temperature	34° to 39°F 1° to 4°C	34° to 39°F 1° to 4°C		
Low Side Pressure (cut-in)	5 to 12 psig 34 to 83 kPa	5 to 12 psig 34 to 83 kPa		
Low Side Pressure (cut-out)	-2 to 2 psig -14 to 14 kPa	-2 to 2 psig -14 to 14 kPa		
High Side Pressure (Last 1/3 of cycle)	90 to 115 psig 621 to 793 kPa	130 to 155 psig 896 to 1069 kPa		
Wattage (Last 1/3 of cycle)	120 to 150	130 to 160		
Amps (Running)	1.2 to 1.5	1.2 to 1.5		
Base Voltage	115 vac (127 vac max)	115 vac (127 vac max)		
DEFROST SPECIFICATIONS				
Cabinet Size	Thermostat		Heater	
	Cut-in	Cut-out	Watts	Ohms
23' & 26'	25°F -4°C	47°F 8°C	450	30
Electronic Timer - (ADC) Defrost 24 minutes every 6 to 72 hours of compressor run time.				
CONDENSER FAN MOTOR				
Watts	RPM	Amps		
7	1100 CW Opposite Shaft	.1 Running		
ICE MAKER SPECIFICATIONS				
Electrical	115 vac (127 vac max)	60 Hertz		
Thermostat	Opens at 48°F (9°C)	Closes at 15°F (-9°C)		
Heater Wattage	165			
ICE MAKER CONNECTOR PLUG CONNECTIONS				
Wire Number	Wire Color	Connects to:		
1	Green/Yellow	Ground		
2	Yellow	Water Valve		
3	Black	Line		
4	Lt. Blue	Neutral		

## SERVICE DATA SHEET - 240389616

### R134a ICE & WATER - AUTOMATIC DEFROST SIDE BY SIDE MODELS

**IMPORTANT SAFETY NOTICE**

The information provided herein is designed to assist qualified repair personnel only. Untrained persons should not attempt to make repairs due to the possibility of electrical shock. Disconnect power cord before servicing.

**IMPORTANT**

If any green grounding wires are moved during servicing, they must be returned to their original position and properly secured.

**CAUTION: All electrical parts and wiring must be shielded from torch flame. Do not allow torch to contact insulation; it will char at 200°F and flash ignite (burn) at 500°F. Excessive heat will distort the plastic liner.**

**NOTE:** This product comes equipped with an Electronic Defrost Control. To initiate defrost, depress the fresh food light switch 5 times in 6 seconds (light bulb must be working). To terminate defrost, depress the fresh food light switch 5 times in 6 seconds.

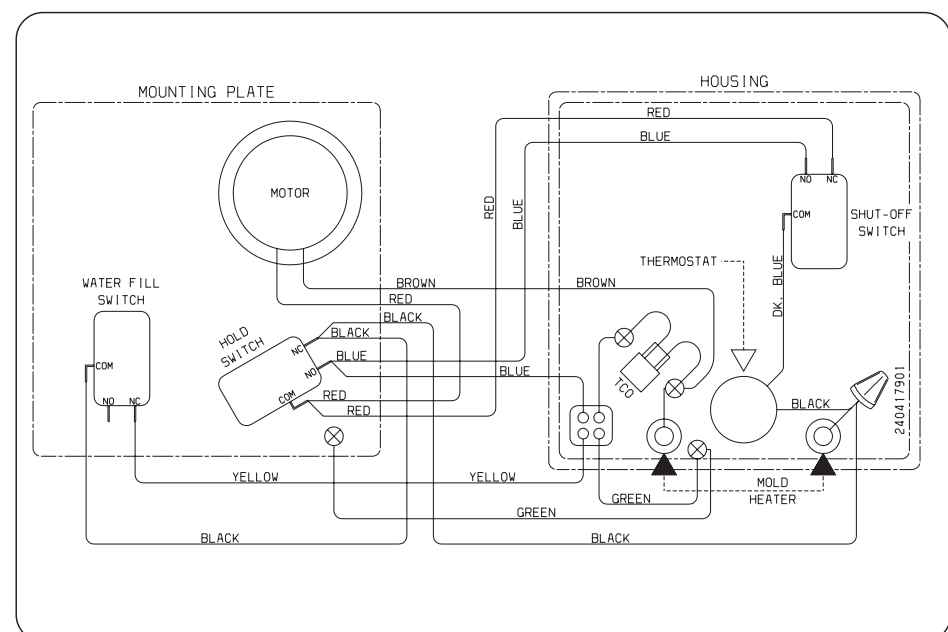

### ICE MAKER INFORMATION

#### Test Cycling

Remove cover by inserting screwdriver in notch at bottom and prying cover from housing. Use screwdriver to rotate motor gear counterclockwise until holding switch circuit is completed. All components of ice maker should function to complete the cycle.

#### Water Fill Volume

The water fill adjustment screw will change the fill time. One full turn is equal to 20cc (.68 oz.). The correct fill is 102 to 130cc (3.4 to 4.3 oz.). When a water valve is replaced, the fill volume must be checked.

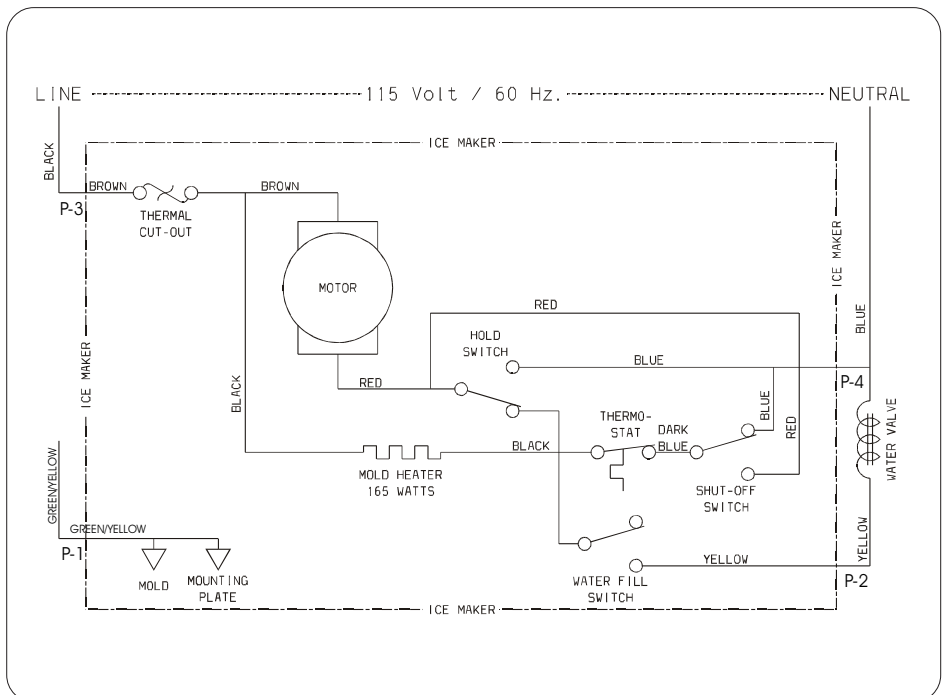

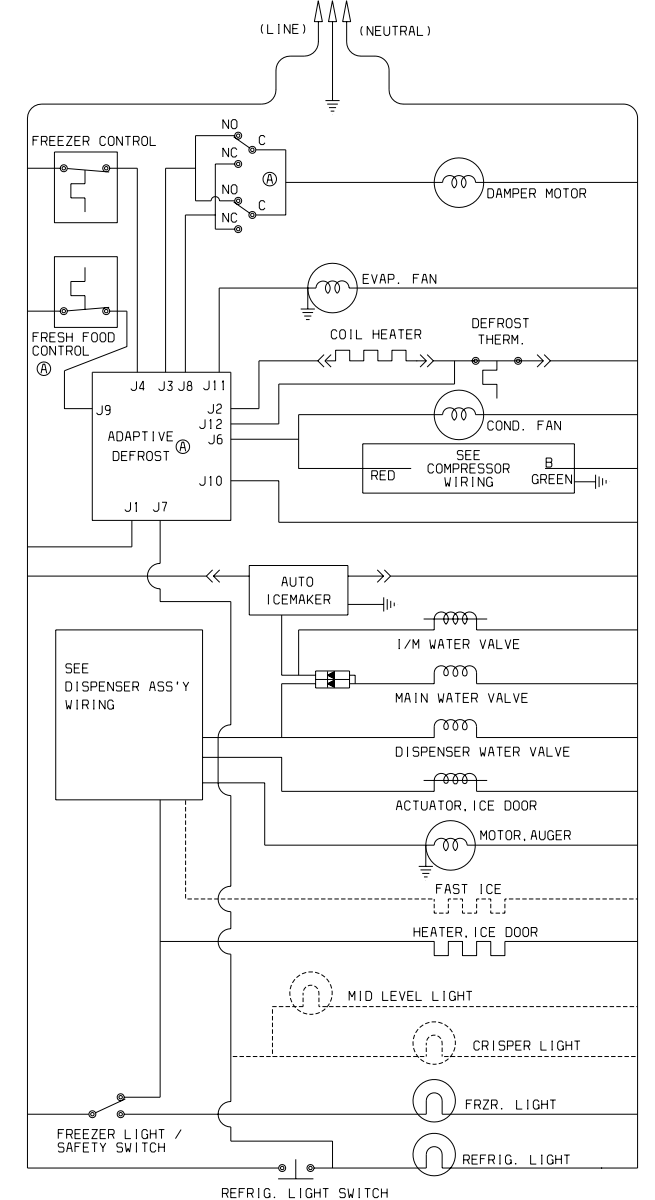
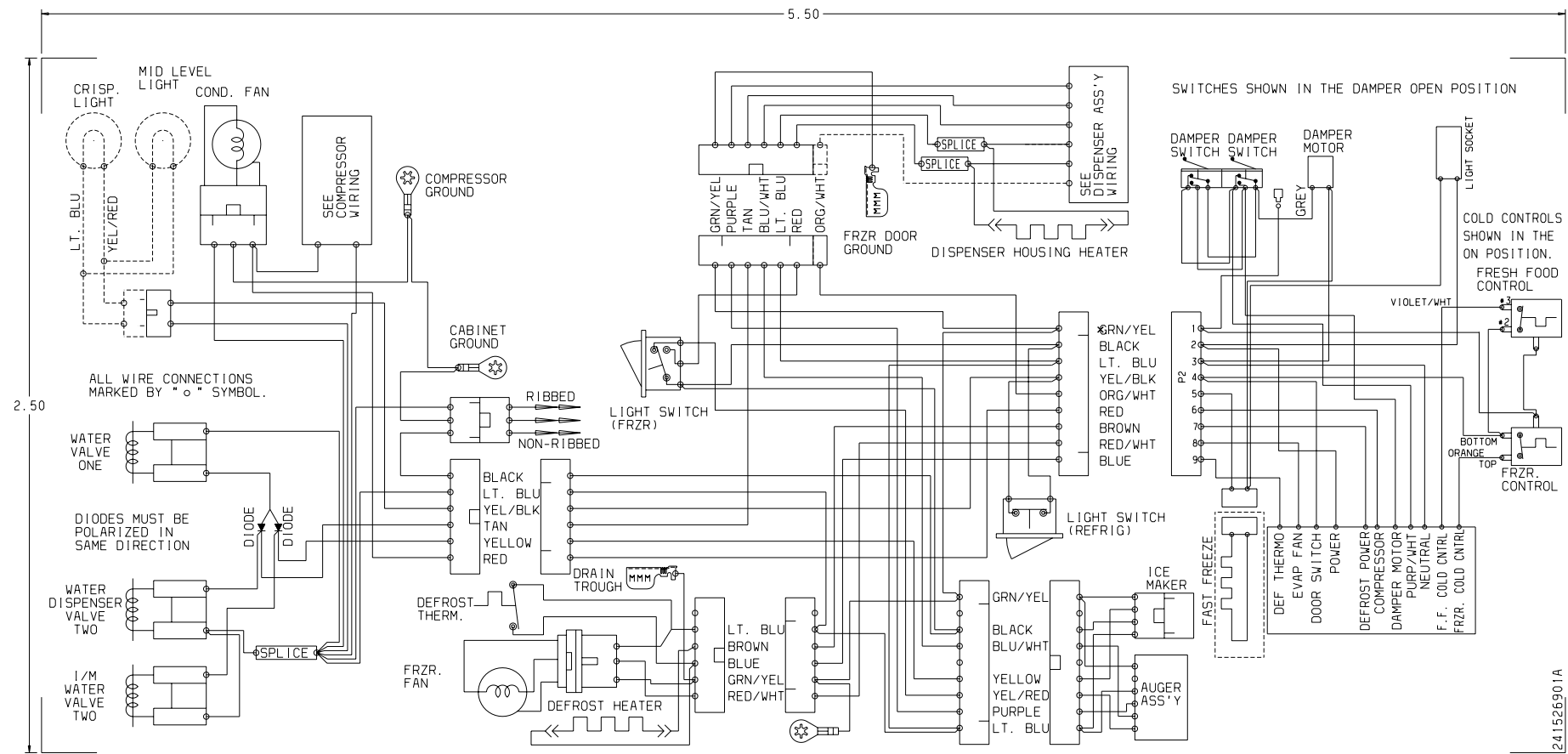

ELECTRONIC DISPENSER

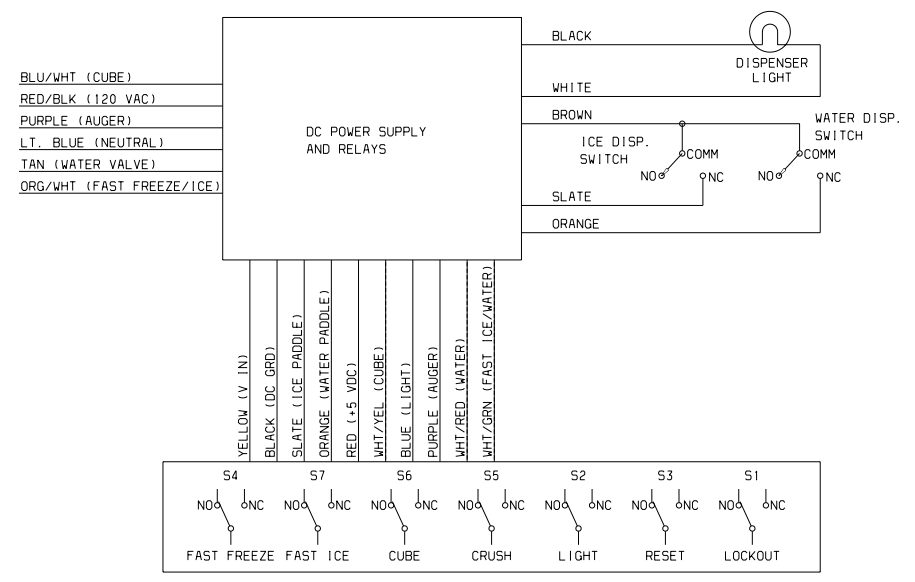

ELECTRO-MECHANICAL DISPENSER

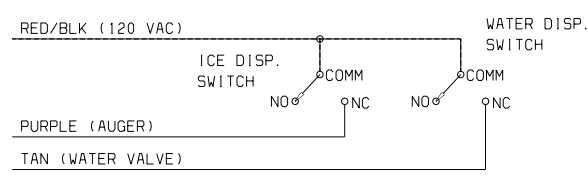

P.T.C. STARTER WITH RUN CAPACITOR

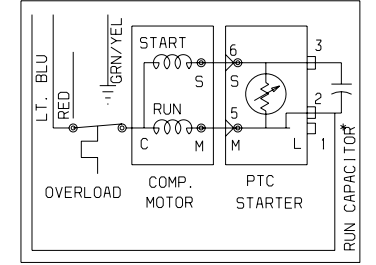

\* CAPACITOR IS ONLY USED WITH SOME P.T.C. MODELS.

SERVICE PARTS	23 CUBIC FOOT		26 CUBIC FOOT	
	STANDARD	E-STAR	STANDARD	E-STAR
Compressor Kit *	5303918303	5303918299	5303918303	5303918298
Starter/PTC/TSD *	241524604	241527802	241524604	241527801
Run Capacitor *	218909913	218909915	218909913	218909915
Temp. Control-Refr	241507701	241507701	241507701	241507701
Temp. Control-Frzz	450226-07	450226-07	450226-07	450226-07
Timer (if applicable)	N/A	N/A	N/A	N/A
ADC (if applicable)	241508001	241508001	241508001	241508001
Defrost Heater Kit	5303918253	5303918253	5303918253	5303918253
Defrost Thermostat Kit	5303918214	5303918214	5303918214	5303918214
Evaporator Fan Motor	240369701	240369701	240369701	241537301
Condenser Fan Motor	240523601	241538001	240523601	241538001

\* Typical compressor kit includes compressor, electrical components, and filter-drier

PERFORMANCE DATA NO LOAD AND NO DOOR OPENINGS AT MID-POINT CONTROL SETTING				
Type A With Run/Start Capacitor	65°F (18°C) Ambient	90°F (32°C) Ambient		
Operating Time	32 to 40%	55 to 65%		
Freezer Temperature	0° to 4°F -18° to -16°C	-1° to 3°F -18° to -16°C		
Refrigerator Temperature	34° to 39°F 1° to 4°C	34° to 39°F 1° to 4°C		
Low Side Pressure (cut-in)	5 to 12 psig 34 to 83 kPa	5 to 12 psig 34 to 83 kPa		
Low Side Pressure (cut-out)	-2 to 2 psig -14 to 14 kPa	-2 to 2 psig -14 to 14 kPa		
High Side Pressure (Last 1/3 of cycle)	90 to 115 psig 621 to 793 kPa	130 to 155 psig 896 to 1069 kPa		
Wattage (Last 1/3 of cycle)	120 to 150	130 to 160		
Amps (Running)	1.2 to 1.5	1.2 to 1.5		
Base Voltage	115 vac (127 vac max)	115 vac (127 vac max)		
DEFROST SPECIFICATIONS				
Cabinet Size	Thermostat		Heater	
	Cut-in	Cut-out	Watts	Ohms
23' & 26'	25°F -4°C	47°F 8°C	450	30
Electronic Timer - (ADC) Defrost 24 minutes every 6 to 72 hours of compressor run time.				
CONDENSER FAN MOTOR				
Watts	RPM	Amps		
7	1100 CW Opposite Shaft	.1 Running		
ICE MAKER SPECIFICATIONS				
Electrical	115 vac (127 vac max)	60 Hertz		
Thermostat	Opens at 48°F (9°C)	Closes at 15°F (-9°C)		
Heater Wattage	165			
ICE MAKER CONNECTOR PLUG CONNECTIONS				
Wire Number	Wire Color	Connects to:		
1	Green/Yellow	Ground		
2	Yellow	Water Valve		
3	Black	Line		
4	Lt. Blue	Neutral		

**SERVICE DATA SHEET - 240389618**  
**R134a**  
**ICE & WATER - AUTOMATIC DEFROST**  
**SIDE BY SIDE MODELS**

**IMPORTANT SAFETY NOTE**  
The information provided herein is designed to assist qualified repair personnel only. Untrained persons should not attempt to make repairs due to the possibility of electrical shock. Disconnect power cord before servicing this appliance.  
**IMPORTANT**  
If any green grounding wires are removed during servicing, they must be returned to their original position and properly secured.

**CAUTION**  
All electrical parts and wiring must be shielded from torch flame. DO NOT allow torch to touch insulation; it will char at 200°F and flash ignite (burn) at 500°F. Excessive heat will distort the plastic liner.

**NOTE**  
This product comes equipped with an Electronic Defrost Control. To initiate defrost, depress the fresh food light switch 5 times in 6 seconds (light bulb must be working). To terminate defrost, depress the fresh food light switch 5 times in 6 seconds.

## ICE MAKER INFORMATION

### Test Cycling

Press the momentary contact on the ON/OFF switch for approximately 15 seconds. Ice maker will continue to complete the cycle.

### Water Fill Volume

Remove cover by inserting screwdriver in notch at bottom and prying cover from housing. The water fill adjustment screw will change the fill time. One turn is equal to 20cc (.68 oz.). The correct fill is 102 to 110cc (3.25 to 3.5 oz.). When a water valve is replaced, the fill volume must be checked

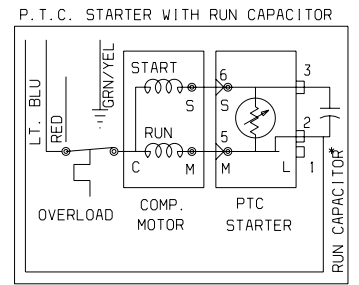
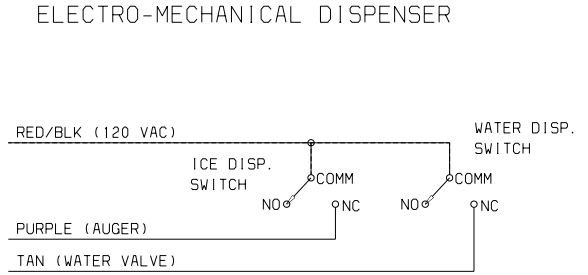
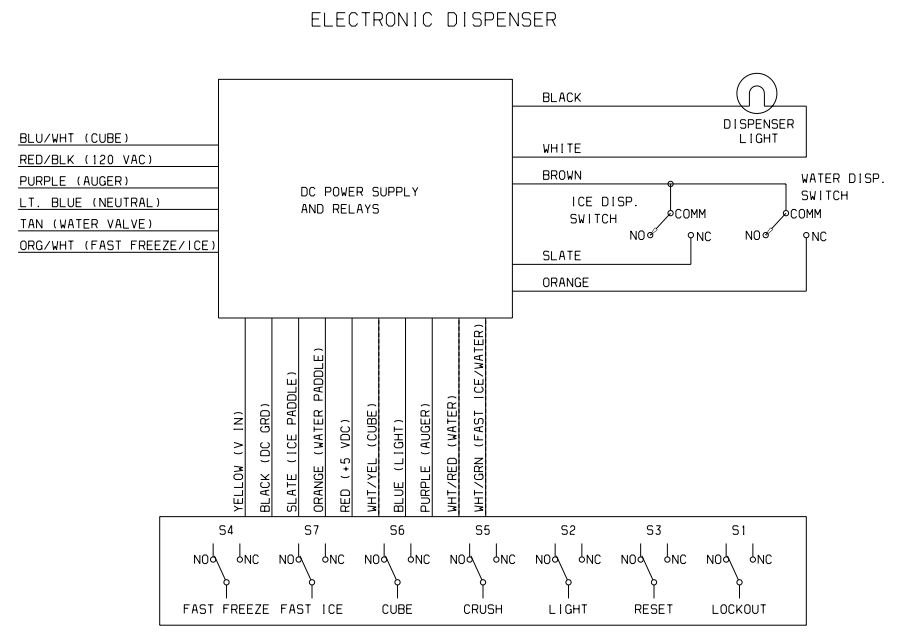
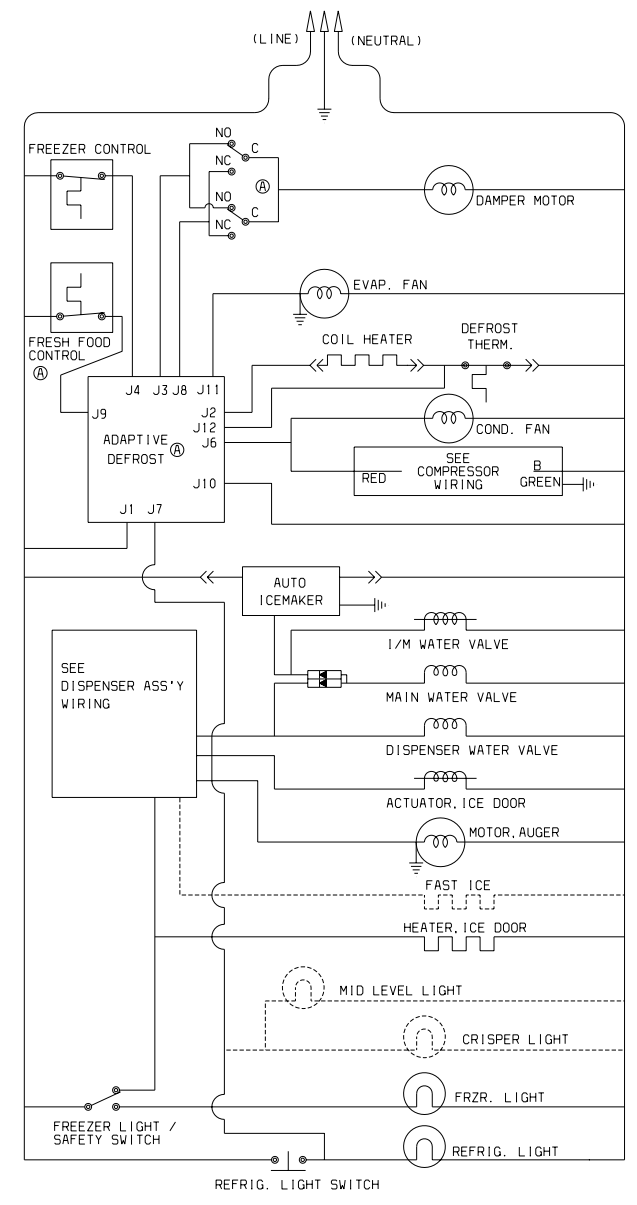
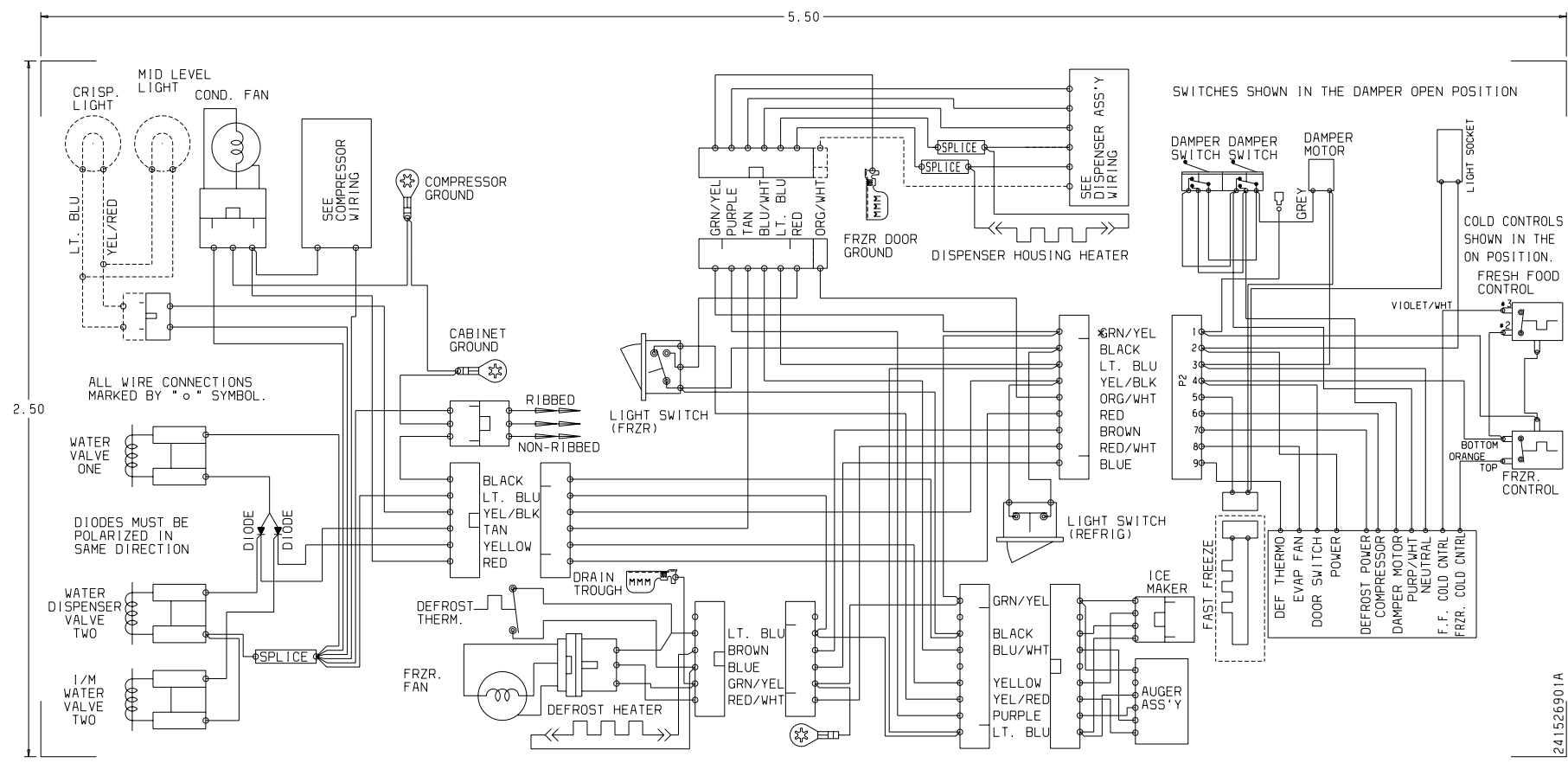

SERVICE PARTS	23 CUBIC FOOT		26 CUBIC FOOT	
	STANDARD	E-STAR	STANDARD	E-STAR
Compressor Kit *	5303918303	5303918299	5303918303	5303918298
Starter/PTC/TSD *	241524604	241527802	241524604	241527801
Run Capacitor *	218909913	218909915	218909913	218909915
Temp. Control-Refr	241507701	241507701	241507701	241507701
Temp. Control-FrZR	450226-07	450226-07	450226-07	450226-07
Timer (if applicable)	N/A	N/A	N/A	N/A
ADC (if applicable)	241508001	241508001	241508001	241508001
Defrost Heater Kit	5303918253	5303918253	5303918253	5303918253
Defrost Thermostat Kit	5303918214	5303918214	5303918214	5303918214
Evaporator Fan Motor	240369701	240369701	240369701	241537301
Condenser Fan Motor	240523601	241538001	240523601	241538001

\* Typical compressor kit includes compressor, electrical components, and filter-drier





PERFORMANCE DATA				
NO LOAD AND NO DOOR OPENINGS AT MID-POINT CONTROL SETTING				
Type A with Run/Start Capacitor	65°F (18°C) Ambient		90°F (32°C) Ambient	
	Variable Speed	Standard	Variable Speed	Standard
Operating Time	74 to 84%	32 to 40%	100%	55 to 65%
Freezer Temperature	-2° to 2°F -19° to -17°C	0° to 4°F -18° to -16°C	-1° to 3°F -18° to -16°C	-1° to 3°F -18° to -16°C
Refrigerator Temperature	34° to 39°F 1° to 4°C	34° to 39°F 1° to 4°C	34° to 39°F 1° to 4°C	34° to 39°F 1° to 4°C
Low Side Pressure (cut-in)	5 to 12 psig 43 to 83 kPa	5 to 12 psig 43 to 83 kPa	N/A	5 to 12 psig 43 to 83 kPa
Low Side Pressure (cut-out)	-2 to 2 psig -14 to 14kPa	-2 to 2 psig -14 to 14kPa	-2 to 2 psig -14 to 14kPa	-2 to 2 psig -14 to 14kPa
High Side Pressure (last 1/3 cycle)	90 to 105 psig 621 to 724 kPa	90 to 115 psig 621 to 793 kPa	120 to 135 psig 827 to 931 kPa	130 to 155 psig 896 to 1069 kPa
Wattage (last 1/3 cycle)	60 to 65	120 to 150	65 to 80	130 to 160
Amps (running)	.7 to 1.1	1.0 to 1.4	.9 to 1.3	1.1 to 1.5
Base Voltage	115 vac (127 vac max)		115 vac (127 vac max)	
DEFROST SPECIFICATIONS				
Cabinet Size	Thermostat		Heater	
	Cut-in	Cut-out	Watts	Ohms
23'	25°F (-4°C)	47°F (8°C)	450	30
Electronic Timer – (ADC) Defrost 24 minutes every 6 – 96 hours of compressor run time.				
CONDENSER FAN MOTOR				
Watts	RPM		Amps	
2.8	950 CW Opposite Shaft		.1 Running	
ICE MAKER SPECIFICATIONS				
Electrical	115 vac (127 vac max)			
Thermostat	Opens at 48°F (9°C)		Closes at 15°F (-9°C)	
Heater Voltage	85 vac			
ICE MAKER CONNECTOR PLUG CONNECTIONS				
Wire Number	Wire Color	Connects to:		
1	Green/Yellow	Ground		
2	Yellow	Water Valve		
3	Black	Line		
4	Light Blue	Neutral		

## IMPORTANT

Please return this sheet to its original location.

## SERVICE DATA SHEET

241532603

ICE & WATER - AUTOMATIC DEFROST  
COUNTER DEPTH SIDE BY SIDE - R134a

## IMPORTANT SAFETY NOTE

The information provided herein is designed to assist qualified repair personnel only. Untrained persons should not attempt to make repairs due to the possibility of electrical shock. Disconnect power cord before servicing this appliance.

### IMPORTANT

If any green grounding wires are removed during servicing, they must be returned to their original position and properly secured.

## CAUTION

All electrical parts and wiring must be shielded from torch flame. DO NOT allow torch to touch insulation; it will char at 200°F and flash ignite (burn) at 500°F. Excessive heat will distort the plastic liner.

## NOTE

This product comes equipped with an Adaptive Defrost Control (ADC). To activate manual defrost, press and hold the Freezer temperature UP (WARMER) key while pressing the Fresh Food temperature DOWN (COLDER) key 5 times within 6 seconds. A “d” in the freezer temperature window and “F” in the refrigerator temperature window will display when the heater is activated. To deactivate manual defrost, press and hold Freezer temperature UP (WARMER) key while pressing the Fresh Food temperature DOWN (COLDER) key 5 times within 6 seconds. “d” and “F” will be displayed until the defrost cycle is complete. (approx. 8 minutes)

## ICE MAKER INFORMATION

### Test Cycling

Press the momentary contact on the ON/OFF switch for approximately 15 seconds. Ice maker will continue to complete the cycle.

### Water Fill Volume

Remove cover by inserting screwdriver in notch at bottom and prying cover from housing. The water fill adjustment screw will change the fill time. One turn is equal to 20cc (.68 oz.). The correct fill is 102 to 110cc (3.25 to 3.5 oz.). When a water valve is replaced, the fill volume must be checked

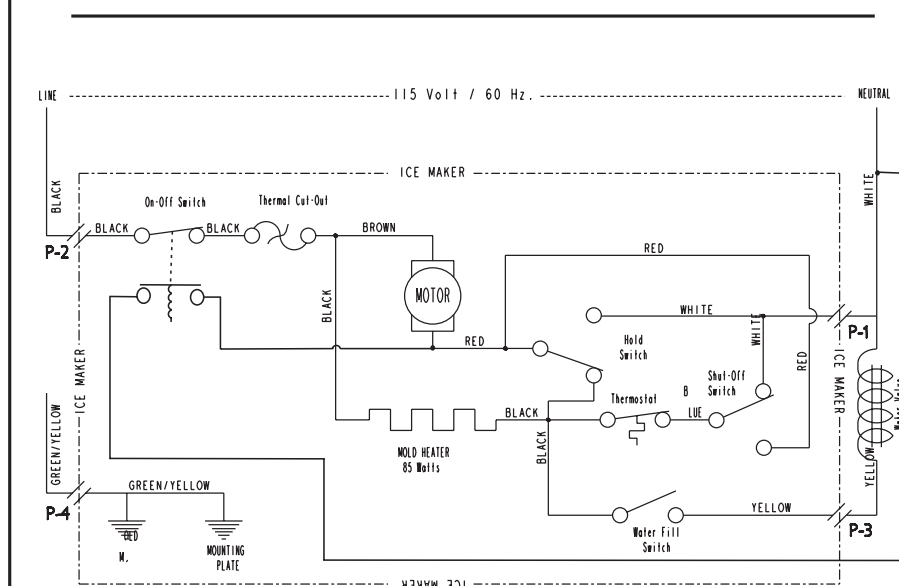
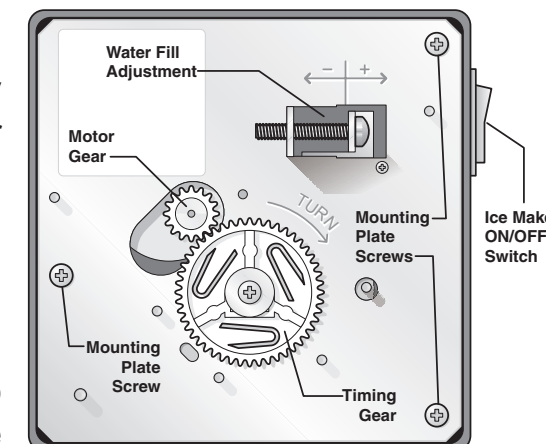

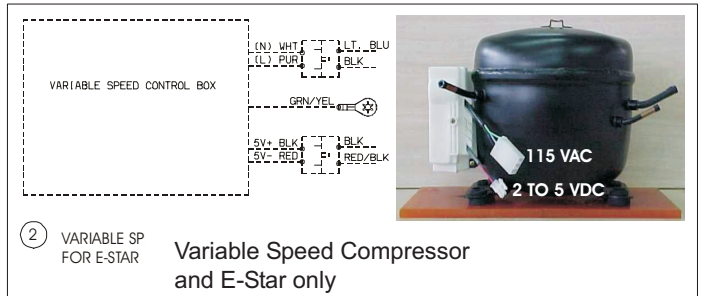
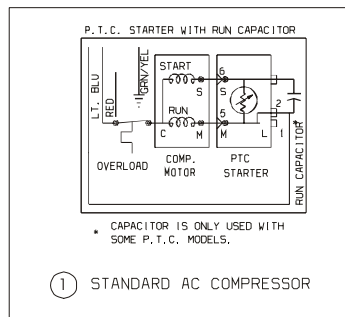
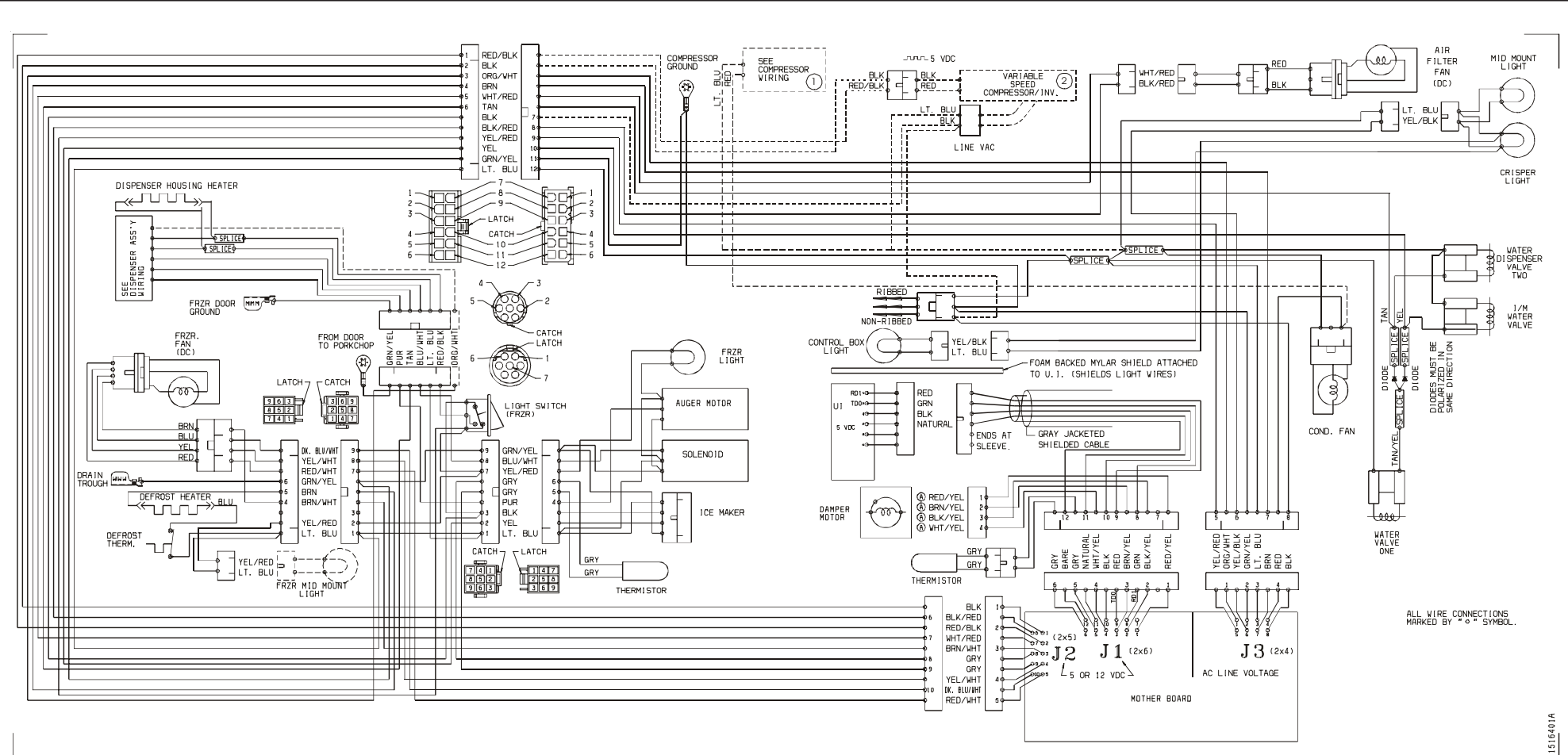

Variable Speed Compressor and E-Star only

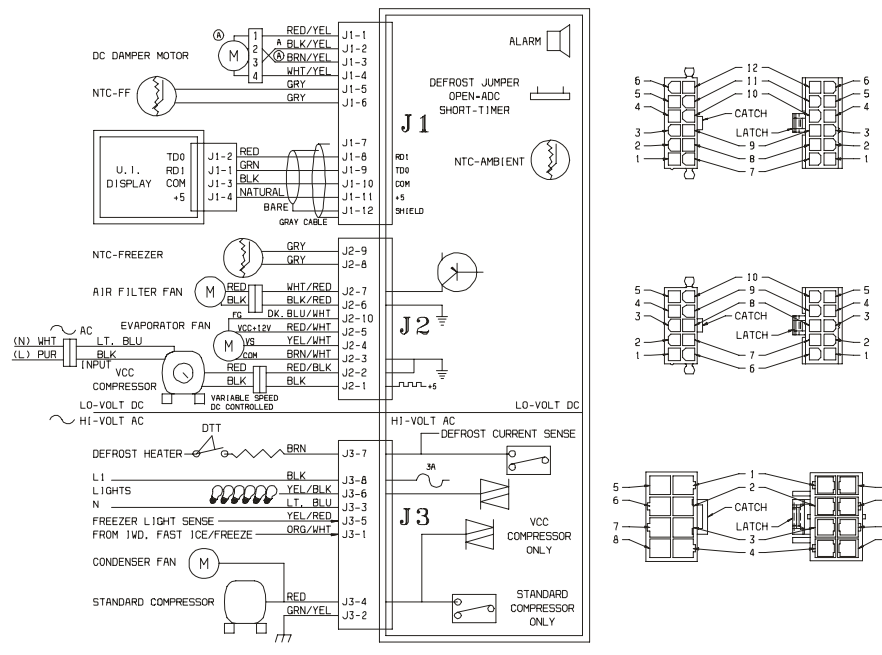
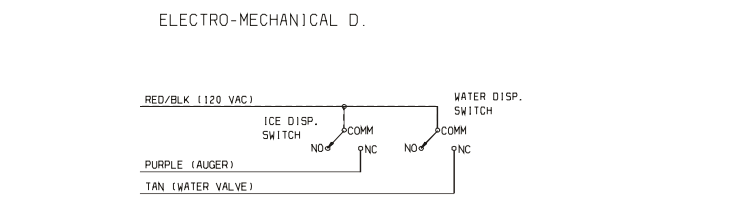
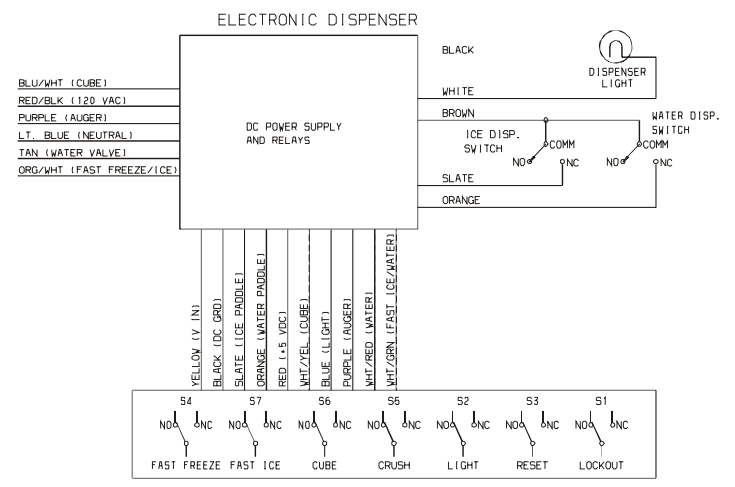

SERVICE PARTS	23 CUBIC FOOT	
	STANDARD (1)	E-STAR (2)
Compressor Kit *	5303918298	241547601
Power Board (Sigma Main)	N/A	241511102
Inverter	N/A	241577501
Starter/PTC	241527801	N/A
Run Capacitor	218909915	N/A
Sensor, Temperature	240597201	240597201
Damper Assembly	241518401	241518401
Defrost Heater Kit	5303918253	5303918253
Defrost Thermostat Kit	5303918214	5303918214
Evaporator Fan Motor	241509401	241509401
Condenser Fan Motor	241537901	241537901

\* Typical Compressor Kit includes compressor, electrical components and filter-drier.

241516401A

