

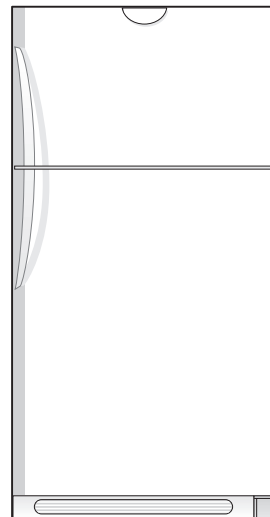

ELECTROLUX HOME PRODUCTS NORTH AMERICA

Product Information and Technical Guide

*Next Generation
Side by Side and Top Mount Refrigerators
June 2001 - March 2002*



Frigidaire[®]

TAPPAN[®]

W White-Westinghouse[®]

Kelvinator[®] 

Gibson[®]

TABLE OF CONTENTS

SAFE SERVICING PRACTICES ----- 2

SERVICE DATA SHEET, REFRIGERANT CHARGE & ENERGY EFFICIENCY RATING INDEXES

Frigidaire ----- 3 - 11
 Gibson ----- 11 - 12
 White-Westinghouse ----- 12 - 13
 Amana ----- 13

TROUBLESHOOTING GUIDE ----- 14 - 18

APPENDIX A - SERVICE DATA SHEETS

240379005 ----- A1 - A2
 240379006 ----- A3 - A4
 240379007 ----- A5 - A6
 240379009 ----- A7 - A8
 240389604 ----- A9 - A10
 240389605 ----- A11 - A12
 240389606 ----- A13 - A14
 240389607 ----- A15 - A16

NOTE: The asterisk (*) in the model part numbers on pages 3-13 is the letter code for the color of the refrigerator. Please see the chart below.

Color Codes
B = Black
C = Bisque (Amana)
Q = Bisque
S = Stainless
T = Bisque
W = White
Z = Stain/Blk

SAFE SERVICING PRACTICES - ALL APPLIANCES

To avoid personal injury and/or property damage, it is important that **Safe Servicing Practices** be observed. The following are some limited examples of safe practices:

1. **DO NOT** attempt a product repair if you have any doubts as to your ability to complete it in a safe and satisfactory manner.
2. Before servicing or moving an appliance:
 - Remove the power cord from the electrical outlet, trip the circuit breaker to the OFF position, or remove the fuse.
 - Turn off the gas supply.
 - Turn off the water supply.
3. Never interfere with the proper operation of any safety device.
4. **USE ONLY REPLACEMENT PARTS CATALOGED FOR THIS APPLIANCE. SUBSTITUTIONS MAY DEFEAT COMPLIANCE WITH SAFETY STANDARDS SET FOR HOME APPLIANCES.**
5. **GROUNDING:** The standard color coding for safety ground wires is **GREEN**, or **GREEN** with **YELLOW STRIPES**. Ground leads are not to be used as current carrying conductors. It is **EXTREMELY** important that the service technician reestablish all safety grounds prior to completion of service. Failure to do so will create a hazard.
6. Prior to returning the product to service, ensure that:
 - All electrical connections are correct and secure
 - All electrical leads are properly dressed and secured away from sharp edges, high-temperature components, and moving parts
 - All non-insulated electrical terminals, connectors, heaters, etc. are adequately spaced away from all metal parts and panels
 - All safety grounds (both internal and external) are correctly and securely connected
 - All panels are properly and securely reassembled

ATTENTION!!!

This service manual is intended for use by persons having electrical and mechanical training and a level of knowledge of these subjects generally considered acceptable in the appliance repair trade. Electrolux Home Products, Inc. cannot be responsible, nor assume any liability, for injury or damage of any kind arising from the use of this manual.

FRIGIDAIRE MODELS				
Model	Service Data Sheets		R-134a Refrigerant Charge (ounces)	Energy Efficiency Rating (kwh/yr)
	Number	Pages		
FRS23F5A*2	240389604	A9 - A10	5	686
FRS23F5A*3	240389604	A9 - A10	5	686
FRS23F5A*4	240389604	A9 - A10	5	686
FRS23F5A*5	240389607	A15 - A16	5	686
FRS23H5AS*0	240389604	A9 - A10	5	617
FRS23H5AS*1	240389604	A9 - A10	5	617
FRS23H5AS*	240389607	A15 - A16	5	617
FRS23HF5A*1	240389604	A9 - A10	5	617
FRS23HF5A*2	240389604	A9 - A10	5	617
FRS23HF5A*3	240389604	A9 - A10	5	617
FRS23HF5A*4	240389607	A15 - A16	5	617
FRS23KF7A*2	240389604	A9 - A10	5	686
FRS23KF7A*3	240389604	A9 - A10	5	686
FRS23KF7A*4	240389604	A9 - A10	5	686
FRS23KF7A*5	240389607	A15 - A16	5	686
FRS23KR4A*2	240389604	A9 - A10	5	686
FRS23KR4A*3	240389604	A9 - A10	5	686
FRS23KR4A*4	240389604	A9 - A10	5	686
FRS23KR4A*5	240389607	A15 - A 1	5	686
FRS23R4A*2	240389604	A9 - A10	5	686
FRS23R4A*3	240389604	A9 - A10	5	686
FRS23R4A*4	240389604	A9 - A10	5	686
FRS23R4A*5	240389604	A9 - A10	5	686
FRS23R4A*6	240389604	A9 - A10	5	686
FRS23R4A*7	240389604	A9 - A10	5	686
FRS23SM4A*0	240389604	A9 - A10	5	686
FRS23W3A*2	240389604	A9 - A10	5	686
FRS23W3A*3	240389604	A9 - A10	5	686
FRS23W3A*4	240389604	A9 - A10	5	686

* See NOTE on page 1.

FRIGIDAIRE MODELS				
Model	Service Data Sheets		R-134a Refrigerant Charge (ounces)	Energy Efficiency Rating (kwh/yr)
	Number	Pages		
FRS23W3A*5	240389607	A15 - A16	5	686
FRS26F5A*1	240389604	A9 - A10	5.25	727
FRS26F5A*2	240389604	A9 - A10	5.25	727
FRS26F5A*3	240389604	A9 - A10	5.25	727
FRS26F5A*4	240389607	A15 - A16	5.25	727
FRS26H5AS*0	240389604	A9 - A10	5.25	654
FRS26H5AS*1	240389604	A9 - A10	5.25	654
FRS26H5AS*3	240389607	A15 - A16	5.25	654
FRS26HF5A*0	240389604	A9 - A10	5.25	654
FRS26HF5A*1	240389604	A9 - A10	5.25	654
FRS26HF5A*2	240389604	A9 - A10	5.25	654
FRS26HF5A*3	240389607	A15 - A16	5.25	654
FRS26HF6B*0	240389607	A15 - A16	5.25	654
FRS26HF7B*0	240389607	A15 - A16	5.25	654
FRS26HR4A*0	240389604	A9 - A10	5.25	654
FRS26HR4A*1	240389604	A9 - A10	5.25	654
FRS26HR4A*3	240389607	A15 - A16	5.25	654
FRS26KF7A*1	240389604	A9 - A10	5.25	727
FRS26KF7A*3	240389604	A9 - A10	5.25	727
FRS26KF7A*4	240389607	A15 - A16	5.25	727
FRS26KR4A*1	240389604	A9 - A10	5.25	727
FRS26KR4A*3	240389604	A9 - A10	5.25	727
FRS26KR4A*4	240389607	A15 - A16	5.25	727
FRS26KW3A*1	240389604	A9 - A10	5.25	727
FRS26KW3A*3	240389604	A9 - A10	5.25	727
FRS26KW3A*4	240389606	A13 - A14	5.25	727
FRS26R2A*0	240389604	A9 - A10	5.25	727
FRS26R2A*1	240389604	A9 - A10	5.25	727
FRS26R2A*2	240389604	A9 - A10	5.25	727

* See NOTE on page 1.

FRIGIDAIRE MODELS				
Model	Service Data Sheets		R-134a Refrigerant Charge (ounces)	Energy Efficiency Rating (kwh/yr)
	Number	Pages		
FRS26R2A*3	240389607	A15 - A16	5.25	727
FRS26R4A*1	240389604	A9 - A10	5.25	727
FRS26R4A*2	240389605	A11 - A12	5.25	727
FRS26R4A*3	240389605	A11 - A12	5.25	727
FRS26R4A*4	240389604	A9 - A10	5.25	727
FRS26R4A*5	240389607	A15 - A16	5.25	727
FRS26SM4A*0	240389604	A9 - A10	5.25	727
FRS26SM4A*2	240389604	A9 - A10	5.25	727
FRS26SM4A*3	240389607	A15 - A16	5.25	727
FRS26W2A*1	240389604	A9 - A10	5.25	727
FRS26W2A*2	240389604	A9 - A10	5.25	727
FRS26W2A*3	240389604	A9 - A10	5.25	727
FRS26W2A*4	240389607	A15 - A16	5.25	727
FRS26W2BS*0	240389607	A15 - A16	5.25	727
FRS26XAJ*1	***	***	5.25	727
FRS26XBJ*0	***	***	5.25	654
FRT14A2A*0	240379007	A5 - A6	4.25	440
FRT14A2A*1	240379007	A5 - A6	4.5	440
FRT14B4A*0	240379007	A5 - A6	4.25	440
FRT14B4A*1	240379007	A5 - A6	4.5	440
FRT14G4B*0	240379007	A5 - A6	4.5	440
FRT14G5A*0	240379007	A5 - A6	4.25	440
FRT14G5A*1	240379007	A5 - A6	4.25	440
FRT15B3A*1	240379007	A5 - A6	4.25	443
FRT15B3A*2	240379007	A5 - A6	4.5	443
FRT15G4A*0	240379007	A5 - A6	4.25	443
FRT15G4A*1	240379007	A5 - A6	4.5	443
FRT15G4B*0	240379007	A5 - A6	4.5	443
FRT15G5A*0	240379007	A5 - A6	4.25	443

* See NOTE on page 1. *** Information not available at time of printing.

FRIGIDAIRE MODELS				
Model	Service Data Sheets		R-134a Refrigerant Charge (ounces)	Energy Efficiency Rating (kwh/yr)
	Number	Pages		
FRT15GG3A*0	240379007	A5 - A6	4.25	443
FRT15IB3A*1	240379007	A5 - A6	4.25	443
FRT15IB3A*2	240379007	A5 - A6	4.5	443
FRT17A2A*0	240379007	A5 - A6	4.25	460
FRT17A2A*1	240379007	A5 - A6	4.5	460
FRT17B3A*1	240379007	A5 - A6	4.25	460
FRT17B3A*2	240379007	A5 - A6	4.5	460
FRT17G4A*1	240379007	A5 - A6	4.5	460
FRT17G4B*0	240379007	A5 - A6	4.5	460
FRT17G5A*0	240379007	A5 - A6	4.25	460
FRT17G5A*1	240379007	A5 - A6	4.25	460
FRT17GG5A*0	240379007	A5 - A6	4.25	460
FRT17GG5A*1	240379007	A5 - A6	4.25	460
FRT17IB3A*1	240379007	A5 - A6	4.25	460
FRT17IB3A*2	240379007	A5 - A6	4.5	460
FRT17IG5A*1	240379007	A5 - A6	4.25	460
FRT18B4A*2	240379007	A5 - A6	4.25	479
FRT18B4A*4	240379007	A5 - A6	4.5	479
FRT18B5A*1	240379009	A7 - A8	4.5	479
FRT18C5A*4	240379007	A5 - A6	4.25	479
FRT18FS5A*4	240379007	A5 - A6	4.25	479
FRT18FS5A*6	***	***	4.25	479
FRT18G3A*2	240379007	A5 - A6	4.25	479
FRT18G4A*2	240379007	A5 - A6	4.25	479
FRT18G4A*4	240379007	A5 - A6	4.5	479
FRT18G4A*6	240379007	A5 - A6	4.5	479
FRT18G5A*1	240379007	A5 - A6	4.25	479
FRT18GS6A*0	240379007	A5 - A6	4.25	479
FRT18GS6A*2	240379007	A5 - A6	4.25	479

* See NOTE on page 1. *** Information not available at time of printing.

FRIGIDAIRE MODELS				
Model	Service Data Sheets		R-134a Refrigerant Charge (ounces)	Energy Efficiency Rating (kwh/yr)
	Number	Pages		
FRT18HC5A*0	240379007	A5 - A6	4	431
FRT18HC5A*2	240379007	A5 - A6	4.25	431
FRT18HP5A*2	240379007	A5 - A6	4.25	431
FRT18IB4A*2	240379007	A5 - A6	4.25	479
FRT18IB4A*4	240379007	A5 - A6	4.5	479
FRT18IC5A*2	240379007	A5 - A6	4	479
FRT18IC5A*4	240379007	A5 - A6	4.25	479
FRT18IG4A*2	240379007	A5 - A6	4.25	479
FRT18IG4A*4	240379007	A5 - A6	4.5	479
FRT18KC3B*0	240379007	A5 - A6	4.25	479
FRT18KC3B*2	240379007	A5 - A6	4.5	479
FRT18KD3A*4	240379007	A5 - A6	4.5	479
FRT18KS5A*4	240379007	A5 - A6	4.25	479
FRT18KS5A*6	240379007	A5 - A6	4.25	479
FRT18LN5B*0	240379007	A5 - A6	4.5	479
FRT18LR7A*2	240379007	A5 - A6	4.25	431
FRT18ND5A*4	240379007	A5 - A6	4.25	479
FRT18NP7A*0	240379007	A5 - A6	4.25	479
FRT18P5A*3	240379009	A7 - A8	4.25	479
FRT18P5A*4	240379007	A5 - A6	4.25	479
FRT18R6A*2	240379006	A3 - A4	4	479
FRT18R6A*3	240379009	A7 - A8	4.25	479
FRT18R6A*4	240379007	A5 - A6	4.25	479
FRT21B4A*2	240379007	A5 - A6	4.25	509
FRT21C5A*3	240379007	A5 - A6	4.25	509
FRT21FD3A*2	240379005	A1 - A2	4.25	509
FRT21FR6A*2	240379007	A5 - A6	4.25	509
FRT21FR6A*3	240379007	A5 - A6	4.25	509
FRT21FS5A*1	240379005	A1 - A2	4.25	509

* See NOTE on page 1.

FRIGIDAIRE MODELS				
Model	Service Data Sheets		R-134a Refrigerant Charge (ounces)	Energy Efficiency Rating (kwh/yr)
	Number	Pages		
FRT21FS5A*2	240379005	A1 - A2	4.25	509
FRT21FS5A*3	240379007	A5 - A6	4.25	509
FRT21G3A*2	240379007	A5 - A6	4.25	509
FRT21G4B*0	240379007	A5 - A6	4.25	509
FRT21G4B*1	240379009	A7 - A8	4.25	509
FRT21H7AS*0	240379009	A7 - A8	4.25	458
FRT21HP5A*0	240379007	A5 - A6	4.25	458
FRT21HP5A*1	240379007	A5 - A6	4.25	458
FRT21HR6A*1	240379007	A5 - A6	4.25	458
FRT21HR6A*2	240379007	A5 - A6	4.25	458
FRT21HS6A*0	***	***	4.25	458
FRT21HS6A*1	***	***	4.25	458
FRT21IS6B*0	240379009	A7 - A8	4.25	509
FRT21KD3*2	240379007	A5 - A6	4.25	509
FRT21KR6A*2	240379007	A5 - A6	4.25	509
FRT21KR6A*3	240379007	A5 - A6	4.25	509
FRT21KS5A*2	240379007	A5 - A6	4.25	509
FRT21KS5A*3	240379007	A5 - A6	4.25	509
FRT21LR7A*1	240379007	A5 - A6	4.25	458
FRT21LR7A*2	240379007	A5 - A6	4.25	458
FRT21LR7A*3	240379007	A5 - A6	4.25	458
FRT21LR7A*4	240379007	A5 - A6	4.25	458
FRT21LR7A*5	240379009	A7 - A8	4.25	458
FRT21P5A*2	240379005	A1 - A2	4.25	509
FRT21P5A*3	240379007	A5 - A6	4.25	509
FRT21P5A*4	240379009	A7 - A8	4.25	509
FRT21P6BS*0	240379009	A7 - A8	4.25	509
FRT21P6A*2	240379007	A5 - A6	4.25	509
FRT21R7AS*2	240379007	A5 - A6	4.25	509

* See NOTE on page 1. *** Information not available at time of printing.

FRIGIDAIRE MODELS				
Model	Service Data Sheets		R-134a Refrigerant Charge (ounces)	Energy Efficiency Rating (kwh/yr)
	Number	Pages		
FRT21S6A*2	240379005	A1 - A2	4.25	509
FRT21S6A*3	240379007	A5 - A6	4.25	509
FRT21XBJ*0	***	***	4.25	509
FRT21XCJ*0	***	***	4.25	509
FRT21XDJ*0	***	***	4.25	509
FRT21XEJ*0	***	***	4.25	509
GLHS234ZA*1	240389604	A9 - A10	5	617
GLHS237ZA*1	240389604	A9 - A10	5	617
GLHS264ZA*0	240389604	A9 - A10	5.25	654
GLHS267ZA*0	240389604	A9 - A10	5.25	654
GLHT180SA*0	240379007	A5 - A6	4	431
GLHT180SA*2	240379007	A5 - A6	4.25	431
GLHT184RA*2	240379007	A5 - A6	4.25	431
GLHT186TA*0	240379007	A5 - A6	4	431
GLHT186TA*2	240379007	A5 - A6	4.25	431
GLHT214RA*0	240379005	A1 - A2	4.25	458
GLHT214RA*1	240379007	A5 - A6	4.25	458
GLHT216TA*1	240379007	A5 - A6	4.25	458
GLRS234ZA*2	240389604	A9 - A10	5	686
GLRS234ZA*3	240389604	A9 - A10	5	686
GLRS234ZA*4	240389604	A9 - A10	5	686
GLRS234ZA*5	240389607	A15 - A16	5	686
GLRS237ZA*2	240389604	A9 - A10	5	686
GLRS237ZA*3	240389604	A9 - A10	5	686
GLRS237ZA*4	240389604	A9 - A10	5	686
GLRS237ZA*5	240389607	A15 - A16	5	686
GLRS264ZA*1	240389604	A9 - A10	5.25	727
GLRS264ZA*2	240389604	A9 - A10	5.25	727
GLRS264ZA*3	240389604	A9 - A10	5.25	727

* See NOTE on page 1. *** Information not available at time of printing.

FRIGIDAIRE MODELS				
Model	Service Data Sheets		R-134a Refrigerant Charge (ounces)	Energy Efficiency Rating (kwh/yr)
	Number	Pages		
GLRS264ZA*4	240389607	A15 - A16	5.25	727
GLRS267ZA*1	240389604	A9 - A10	5.25	727
GLRS267ZA*2	240389604	A9 - A10	5.25	727
GLRS267ZA*3	240389604	A9 - A10	5.25	727
GLRS267ZA*4	240389607	A15 - A16	5.25	727
GLRT180SA*0	240379007	A5 - A6	4.25	479
GLRT181SA*0	240379007	A5 - A6	4.25	479
GLRT182SA*1	240379007	A5 - A6	4.25	479
GLRT183SB*1	240379007	A5 - A6	4.25	479
GLRT184RA*1	240379007	A5 - A6	4.25	479
GLRT184RA*3	240379007	A5 - A6	4.25	479
GLRT186TA*2	240379007	A5 - A6	4.25	479
GLRT187TA*0	240379007	A5 - A6	4.25	479
GLRT214RA*1	240379007	A5 - A6	4.25	509
GLRT214RA*2	240379007	A5 - A6	4.25	509
GLRT215RB*0	240379009	A7 - A8	4.25	509
GLRT216TA*1	240379007	A5 - A6	4.25	509
GLRT216TA*2	240379007	A5 - A6	4.25	509
NGS18TZA*2	240379007	A5 - A6	4.25	479
NGS21TZA*0	240379005	A1 - A2	4.25	509
NGS21TZA*2	240379009	A7 - A8	4.25	509
NGS23ZZA*1	240389604	A9 - A10	5	686
NGS23ZZA*2	240389604	A9 - A10	5	686
NGS23ZZA*3	240389604	A9 - A10	5	686
NGS23ZZA*4	240389607	A15 - A16	5	686
NGS26ZZA*1	240389604	A9 - A10	5.25	727
NGS26ZZA*3	240389604	A9 - A10	5.25	727
NGS26ZZA*4	240389607	A15 - A16	5.25	727
PLHS237ZA*0	240389604	A9 - A10	5	617

* See NOTE on page 1.

FRIGIDAIRE MODELS				
Model	Service Data Sheets		R-134a Refrigerant Charge (ounces)	Energy Efficiency Rating (kwh/yr)
	Number	Pages		
PLHS237ZA*1	240389604	A9 - A10	5	617
PLHS237ZA*2	240389604	A9 - A10	5	617
PLHS237ZA*3	240389606	A13 - A14	5	617
PLHS267ZA*0	240389604	A9 - A10	5.25	654
PLHS267ZA*1	240389604	A9 - A10	5.25	654
PLHS267ZA*2	240389604	A9 - A10	5.25	654
PLHS267ZA*3	240389607	A15 - A16	5.25	654
PLHT217TA*0	240379007	A5 - A6	4.25	458
PLHT217TA*1	240379007	A5 - A6	4.25	458
PLHT217TA*2	240379007	A5 - A6	4.25	458
PLRS237ZA*1	240389604	A9 - A10	5	686
PLRS237ZA*2	240389604	A9 - A10	5	686
PLRS237ZA*3	240389604	A9 - A10	5	686
PLRS237ZA*4	240389607	A15 - A16	5	686
PLRS267ZA*1	240389604	A9 - A10	5.25	727
PLRS267ZA*3	240389604	A9 - A10	5.25	727
PLRS267ZA*5	240389604	A9 - A10	5.25	727
PLRS267ZA*6	240389606	A13 - A14	5.25	727
PLRT217TA*1	240379007	A5 - A6	4.25	509
PLRT217TA*2	240379007	A5 - A6	4.25	509
GIBSON MODELS				
GRS23F5A*1	240389604	A9 - A10	5	686
GRS23F5A*3	240389604	A9 - A10	5	686
GRS23F5A*4	240389607	A5 - A6	5	686
GRS26F5A*1	240389604	A9 - A10	5.25	727
GRS26F5A*4	240389607	A5 - A6	5.25	727
GRT15C2A*0	240379007	A5 - A6	4.25	443
GRT15C2A*1	240379007	A5 - A6	4.25	443
GRT17C2A*0	240379007	A5 - A6	4.25	460
GRT17C2A*1	***	***	4.25	460

* See NOTE on page 1. *** Information not available at time of printing.

GIBSON MODELS				
Model	Service Data Sheets		R-134a Refrigerant Charge (ounces)	Energy Efficiency Rating (kwh/yr)
	Number	Pages		
GRT17G4A*0	240379007	A5 - A6	4.25	460
GRT17G4A*1	***	***	4.25	460
GRT18C5A*0	240379007	A5 - A6	4	479
GRT18C5A*2	240379007	A5 - A6	4.25	479
GRT18C6A*1	240379009	A7 - A8	4.25	479
GRT18C6A*4	240379007	A5 - A6	4.25	479
GRT18S5A*0	240379007	A5 - A6	4	479
GRT18S5A*2	240379007	A5 - A6	4.25	479
GRT18S6A*1	240379009	A7 - A8	4.25	479
GRT21G6A*2	240379007	A5 - A6	4	479
GRT21G6A*3	240379007	A5 - A6	4.25	479
GRT21G6A*4	240379007	A5 - A6	4.25	479
GRT21N6A*0	240379005	A1 - A2	4.25	509
GRT21N6A*1	240379007	A5 - A6	4.25	509
GRT21N6A*2	240379009	A7 - A8	4.25	509
GRTR21R6A*2	240379007	A5 - A6	4.25	509
GRTR21R6A*3	240379007	A5 - A6	4.25	509
WHITE WESTINGHOUSE MODELS				
WRS23MF5A*1	240389604	A9 - A10	5	686
WRS23MW3A*1	240389604	A9 - A10	5	686
WRS23MW3A*3	240389607	A15 - A16	5	686
WRS23W0A*1	240389604	A9 - A10	5	686
WRS23W0A*3	240389604	A9 - A10	5	686
WRS23W0A*4	240389607	A15 - A16	5	686
WRS26MF5A*2	240389604	A9 - A10	5.25	727
WRT15A0A*0	240379007	A5 - A6	4.25	443
WRT15MB3A*0	240379007	A5 - A6	4.25	443
WRT15MB3A*1	240379007	A5 - A6	4.25	443
WRT17MB3A*0	240379007	A5 - A6	4.25	460

* See NOTE on page 1. *** Information not available at time of printing.

WHITE WESTINGHOUSE MODELS				
Model	Service Data Sheets		R-134a Refrigerant Charge (ounces)	Energy Efficiency Rating (kwh/yr)
	Number	Pages		
WRT17MB3A*1	240379007	A5 - A6	4.25	460
WRT18A0A*4	240379007	A5 - A6	4.5	479
WRT18G4A*4	240379006	A3 - A4	4.5	479
WRT18MP5A*1	240379009	A7 - A8	4.25	479
WRT18MP5A*3	240379009	A7 - A8	4.25	479
WRT21MG3A*0	240379009	A7 - A8	4.25	509
WRT21MR7A*0	240379009	A7 - A8	4.25	509
WRT21S4A*0	240379007	A5 - A6	4.25	509
AMANA MODELS				
Model	Service Data Sheets		R-134a Refrigerant Charge (ounces)	Energy Efficiency Rating (kwh/yr)
	Number	Pages		
ART1805B*2	240379007	A5 - A6	4.25	479
ART2105B*2	240379007	A5 - A6	4.25	509
ART2107B*1	240379007	A5 - A6	4.25	458
ARTE105B*0	240379007	A5 - A6	4.25	458
ARTE105B*1	240379007	A5 - A6	4.25	458
ARTE805B*0	240379007	A5 - A6	4	431
ARTE805B*2	240379007	A5 - A6	4.25	431
BRT21R6A*1	240379009	A7 - A8	4.25	509
DRT1802B*1	240379007	A5 - A6	4.25	479
DRT2102B*2	240379007	A5 - A6	4.25	509
DRT2142B*2	240379007	A5 - A6	4.25	509
DRTE801B*0	240379007	A5 - A6	4.25	431
DRTE801B*1	240379007	A5 - A6	4.25	431
DRT1801B*1	240379007	A5 - A6	4.25	479
DRT1801B*3	240379009	A7 - A8	4.25	431

* See NOTE on page 1.

TROUBLESHOOTING GUIDE

PROBLEM	CAUSE	SOLUTION
Compressor will not run.	No voltage at wall receptacle.	Check circuit breaker, fuse or ground fault circuit interruptors.
	Service cord defective, or unplugged at wall receptacle.	Check cord.
	Low voltage causing compressor to cycle on overload.	Voltage fluctuation should not exceed +/- 10% of 115vac. (104-127)
	Control thermostat knob in OFF position.	Turn control thermostat knob to ON position.
	Inoperative control thermostat.	Replace control thermostat.
	Compressor stuck.	Replace compressor.
	Compressor windings open.	Replace compressor.
	Defrost timer stuck in defrost mode.	Replace defrost timer.
	Compressor overload stuck open.	Replace compressor overload.
	Relay lead loose.	Repair or replace lead.
	Relay loose or inoperative.	Repair or replace relay.
	Service cord pulled out of harness.	Repair connection.
	Faulty cabinet wiring.	Repair wiring.
Compressor runs but does not cool.	System out of refrigerant.	Check for leaks. *
	Compressor not pumping.	Replace compressor. *
	Restricted filter drier.	Replace filter drier. *
	Restricted capillary tube.	Replace heat exchanger and evaporator assembly.
	Moisture in system.	See NOTE. *

- * NOTE:**
- Repair or replace component that is leaking.
 - Replace the compressor if the system is contaminated.
 - Blow out remaining part of system with dry Nitrogen.
 - Pump down and recharge per listing on product serial plate.
 - Always replace filter drier when repairing sealed system.

PROBLEM	CAUSE	SOLUTION
Compressor short cycles.	Erratic control thermostat.	Replace control thermostat.
	Faulty relay.	Replace relay.
	Restricted air flow over condenser.	Ensure unobstructed air flow over condenser.
	Low voltage ... fluctuation exceeds +/- 10% of 115vac (104 - 127)	Call qualified electrician.
	Compressor draws excessive watts.	Replace compressor.
Compressor runs too much.	Control thermostat is erratic, or not properly set.	Replace control thermostat or reset to normal position.
	Refrigerator exposed to high heat. (110° or higher)	Move refrigerator to cooler location.
	High room temperature. (110° or higher)	Advise customer not to install refrigerator where temperature will rise above 110°F because compressor will not maintain proper temperatures.
	Low pumping capacity compressor.	Replace compressor.
	Door gaskets not sealing.	Adjust doors or replace door gaskets.
	System undercharged.	Check for leaks. *
	System overcharged.	Charge per listing on product serial plate. *
	Interior light stays on.	Check door switch and door adjustment.
	Contaminents in system.	Flush out system. Replace filter drier, evacuate, and recharge. *
	Capillary tube kinked or partially restricted.	Replace heat exchanger and evaporator assembly. *
	Filter drier partially restricted.	Replace filter drier. *
	Refrigerator and/or freezer compartment overloaded; poor air circulation.	Advise customer.
	Restricted air flow over condenser.	Ensure unobstructed air flow over condenser.
	Condenser fan motor is inoperative. (forced air condenser models only)	Replace condenser fan motor.

* See NOTE at bottom of page 14

PROBLEM	CAUSE	SOLUTION
---------	-------	----------

Noisy.	Tubing vibrates.	Adjust tubing.
	Internal compressor noise.	Replace compressor.
	Loose parts.	Check shelving.
	Compressor operating at high head pressure due to restricted air flow over condenser.	Ensure unobstructed air flow over condenser.

Freezer compartment too warm.

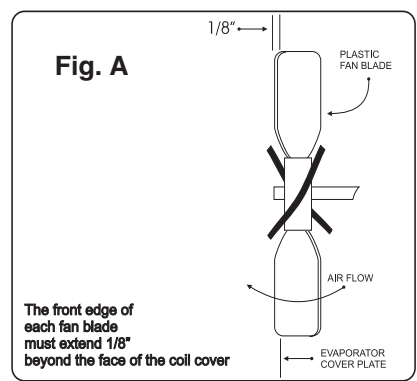

Inoperative evaporator fan motor.	Check wiring and evaporator fan motor.
Improperly positioned fan blade.	Position fan blade properly. See Figure A.
Evaporator frosted up.	Check defrost system, door adjustment, and door gaskets.
Inoperative condenser fan motor. (forced air condenser models only)	Replace condenser fan motor.
Restricted air flow over condenser.	Clean condenser.
Freezer compartment overloaded; poor air circulation.	Advise customer.
Low room temperature. (60° or lower, 55° for models with Service data Sheet numbers 240389600-7 and 240379001-9.)	Advise customer not to install refrigerator where temperature will drop below 60°F. Compressor will not maintain proper temperatures.
Freezer or refrigerator compartment doors left open.	Advise customer.
Control thermostat out of calibration.	Replace control thermostat.
Door gaskets not sealing.	Adjust doors or replace door gaskets.
Control thermostat capillary tube improperly positioned.	Reposition temperature sensing element.
Shortage of refrigerant.	Check for leaks. *
Restricted filter drier or capillary tube.	Check for leaks and burnt compressor windings. *

* See NOTE at bottom of page 14

PROBLEM	CAUSE	SOLUTION
Freezer compartment too cold.	Inoperative cold control.	Replace cold control.
	Freezer compartment inlet air duct is loose or restricted. Door is loose.	Re-install air duct or remove obstruction from inlet air duct. Adjust door.
	Food compartment air return duct blocked.	If foam block is frozen, replace block; if duct is blocked, remove obstruction.
	Diffuser (foam block) in top of food compartment is broken. (Foam block located in Control Housing for models with Service Data Sheets 240389600-7 and 240379001-9)	Replace diffuser.
Refrigerator compartment too warm.	Inoperative evaporator fan motor.	Check wiring and evaporator fan motor.
	Improperly positioned evaporator fan blade.	Position fan blade properly. See page 16, Figure A.
	Refrigerator compartment inlet air duct loose or restricted. Door is loose.	Re-install air duct or remove obstruction from air duct. Adjust door.
	Freezer compartment return air duct restricted.	Remove obstruction from return air duct.
	Low room temperature. (60° or lower, 55° for models with Service data Sheet numbers 240389600-7 and 240379001-9)	Advise customer not to install refrigerator where temperature will drop below 60°F. Compressor will not maintain proper temperatures.
	Damper control out of calibration.	Replace damper control.
	Control thermostat knob set at too warm a position.	Set control knob to a colder position.
	Evaporator frosted up.	Check defrost system, door adjustments, and door gaskets.
	Refrigerator compartment over-loaded; poor air circulation.	Advise customer.
	Refrigerator/freezer compartment doors left open.	Advise customer.
	Inoperative or erratic refrigerator/freezer compartment door switch.	Replace door switch.
Shortage of refrigerant.	Check for leaks. *	
Restricted capillary tube or filter drier.	Check for leaks or burnt compressor windings. *	

* See NOTE at bottom of page 14.

PROBLEM	CAUSE	SOLUTION
Refrigerator compartment too cold.	Inoperative cold control.	Replace cold control.
	Refrigerator compartment inlet air duct loose or restricted. Door is loose.	Re-install air duct or remove obstruction from air duct. Adjust door.
	Diffuser (foam block) in top of food compartment is broken.(Foam block located in Control Housing for models with Service Data Sheets 240389600-7 and 240379001-9)	Replace diffuser.
Evaporator blocked with ice. (See Adaptive Defrost Control below for models with Service Data Sheet numbers 240389600-7 and 240379001-9.)	Inoperative defrost timer.	Check wiring. Repair or replace defrost timer.
	Defrost thermostat terminates too early. Thermostat is open.	Check for correct positioning of defrost thermostat. Repair or replace.
	Refrigerator/freezer compartment doors left open.	Advise customer.
	Heat exchanger and wiring harness openings not sealed.	Seal entrance hole with Permagum or (Food Safe) RTV.
Frozen drain.	Ice maker water line and wiring harness openings not sealed.	Seal water line and wiring harness openings.
	Drain trough not properly formed.	Ensure drain trough is at 90° angle to back of freezer and that lip is up on front and ends.
	Divider (foam block) frozen.	Replace divider. Check drain trough.
Adaptive Defrost Control (ADC) not responding correctly	Faulty ADC board.	Replace ADC board.

PERFORMANCE DATA NO LOAD AND NO DOOR OPENINGS AT MID-POINT CONTROL SETTING		
Type A With Run Capacitor	65°F (18°C) Ambient	90°F (32°C) Ambient
Operating Time	25 to 35%	45 to 55%
Freezer Temperature	2° to 8°F -17° to -13°C	0° to 5°F -18° to -15°C
Refrigerature Temperature	35° to 40°F 2° to 4°C	35° to 40°F 2° to 4°C
Low Side Pressure (cut-in)	8 to 16 psig 55 to 110 kPa	8 to 16 psig 55 to 110 kPa
Low Side Pressure (cut-out)	1 to 4 psig 7 to 28 kPa	1 to 4 psig 7 to 28 kPa
High Side Pressure (Last 1/3 of cycle)	110 to 120 psig 758 to 827 kPa	150 to 175 psig 1034 to 1207 kPa
Wattage (Last 1/3 of cycle)	140 to 185	140 to 185
Amps (Running)	1.1 to 1.6	1.1 to 1.6
Base Voltage	115 VAC	115 VAC

DEFROST SPECIFICATIONS				
Cabinet Size	Thermostat		Heater	
	Cut-in	Cut-out	Watts	Ohms
18' & 21'	25°F -4°C	47°F 8°C	375	35
15' & 17'	25°F -4°C	47°F 8°C	325	41

Defrost 30 Minutes Every 10 Hours of Compressor Run Time

CONDENSER FAN MOTOR		
Watts	RPM	Amps
2.3	1100 CW Opposite Shaft	.15 Running

ICE MAKER SPECIFICATIONS		
Electrical	115 Volts	60 Hertz
Thermostat	Opens at 48°F (9°C)	Closes at 15°F (-9°C)
Heater Wattage	165	

ICE MAKER CONNECTOR PLUG CONNECTIONS		
Wire Number	Wire Color	Connects to:
1	Green/Yellow	Ground
2	Yellow	Water Valve
3	Black	Line
4	Lt. Blue	Neutral

SERVICE DATA SHEET

STANDARD - AUTOMATIC
DEFROST TOP FREEZER
MODELS (R134a)

P/N: 240379005
(12594301)

IMPORTANT SAFETY NOTICE

The information provided herein is designed to assist qualified repair personnel only. Untrained persons should not attempt to make repairs due to the possibility of electrical shock. Disconnect power cord before servicing.

IMPORTANT

If any green grounding wires are moved during servicing, they must be returned to their original position and properly secured.

CAUTION: All electrical parts and wiring must be shielded from torch flame. Do not allow torch to contact insulation; it will char at 200°F and flash ignite (burn) at 500°F. Excessive heat will distort the plastic liner.

ICE MAKER INFORMATION

Test Cycling

Remove cover by inserting screwdriver in notch at bottom and prying cover from housing. Use screwdriver to rotate motor gear counterclockwise until holding switch circuit is completed. All components of ice maker should function to complete the cycle.

Water Fill Volume

The water fill adjustment screw will change the fill time. One full turn is equal to 20cc (.68 oz.). The correct fill is 102 to 130cc (3.4 to 4.3 oz.). When a water valve is replaced, the fill volume must be checked.

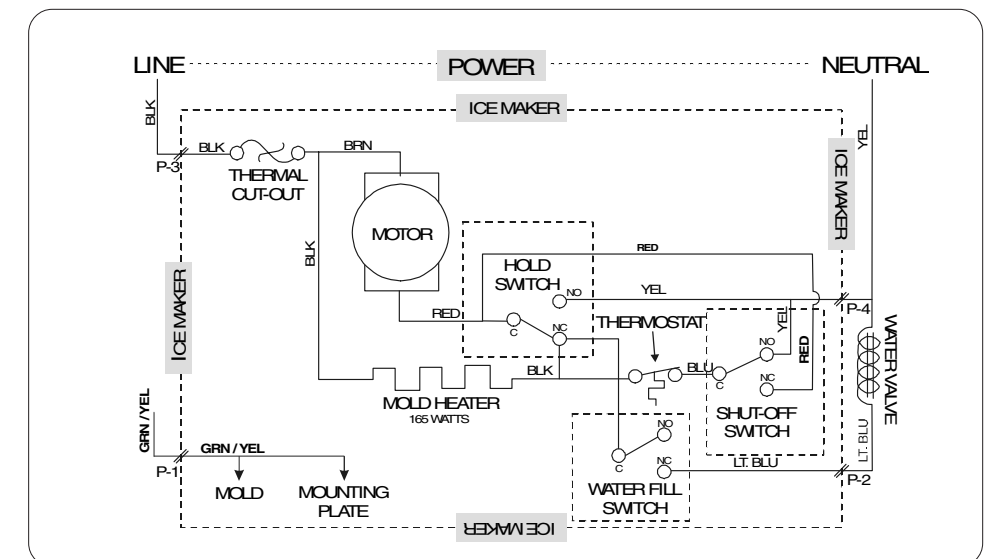
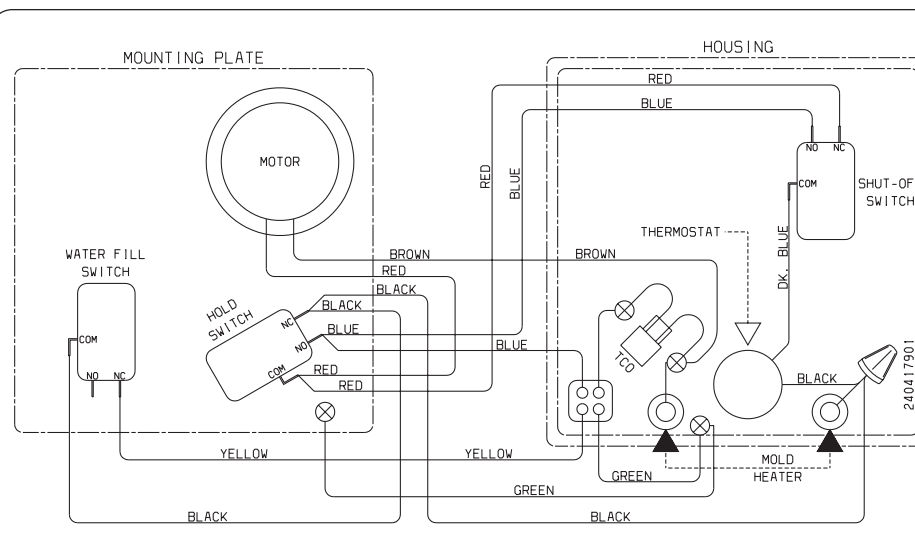
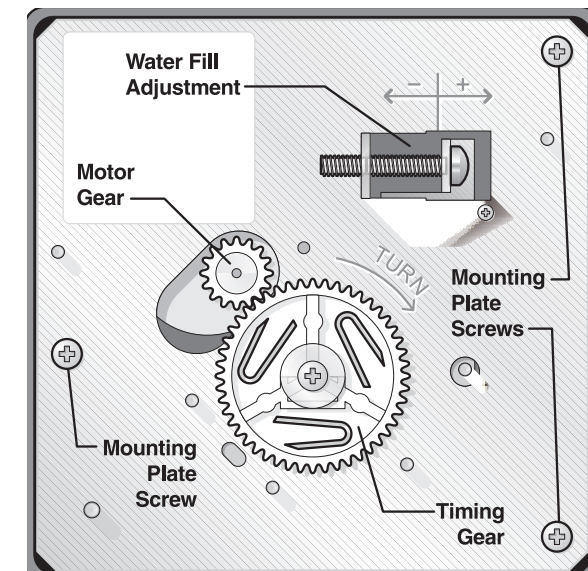

Pictorial Schematic

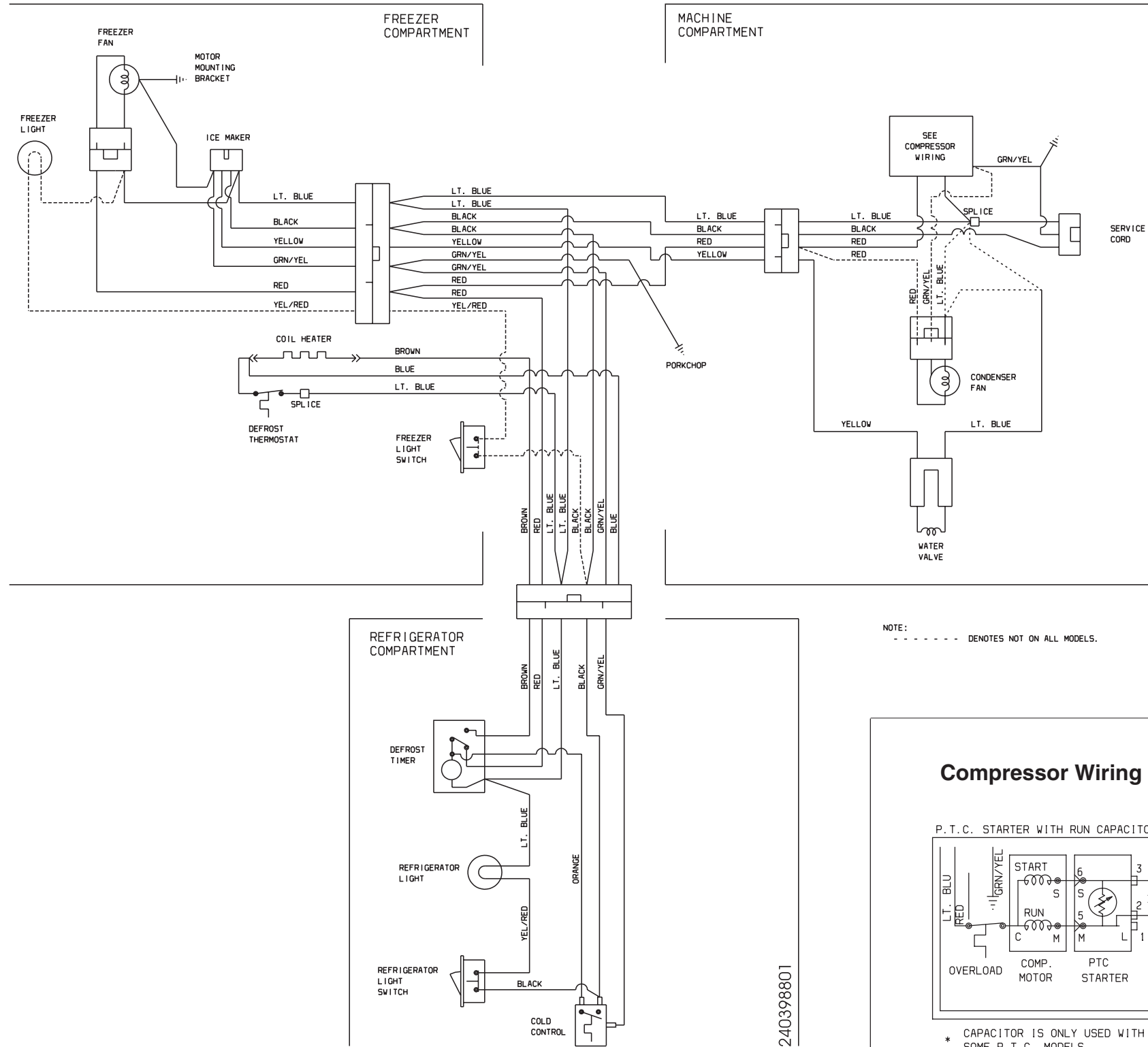

Ladder Schematic

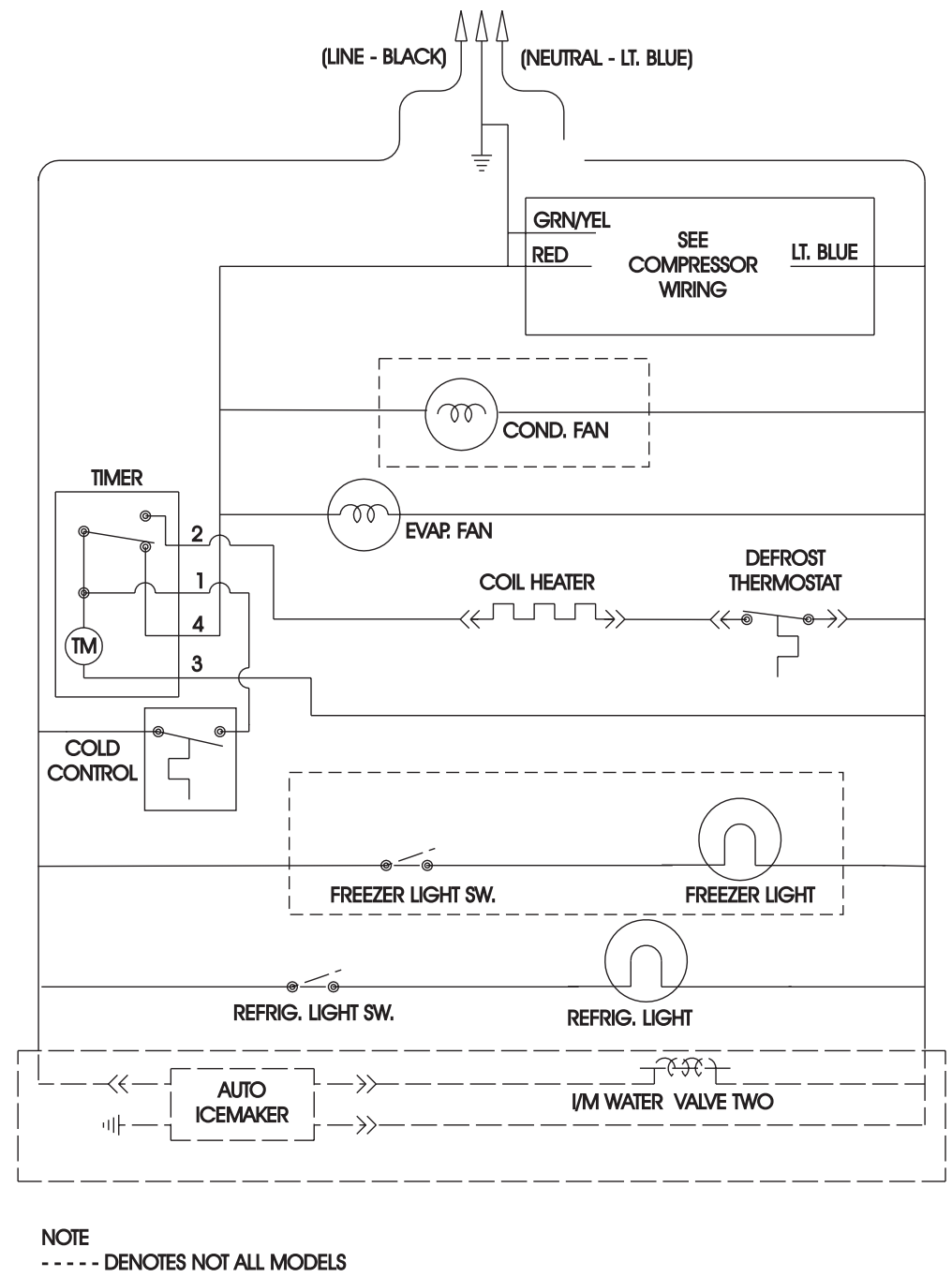

Compressor Wiring

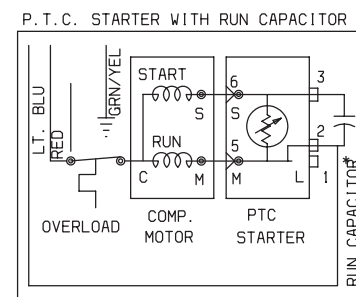

* CAPACITOR IS ONLY USED WITH SOME P.T.C. MODELS.

PERFORMANCE DATA NO LOAD AND NO DOOR OPENINGS AT MID-POINT CONTROL SETTING		
Type A With Run Capacitor	65°F (18°C) Ambient	90°F (32°C) Ambient
Operating Time	25 to 35%	45 to 55%
Freezer Temperature	2° to 8°F -17° to -13°C	0° to 5°F -18° to -15°C
Refrigerature Temperature	35° to 40°F 2° to 4°C	35° to 40°F 2° to 4°C
Low Side Pressure (cut-in)	8 to 16 psig 55 to 110 kPa	8 to 16 psig 55 to 110 kPa
Low Side Pressure (cut-out)	1 to 4 psig 7 to 28 kPa	1 to 4 psig 7 to 28 kPa
High Side Pressure (Last 1/3 of cycle)	110 to 120 psig 758 to 827 kPa	150 to 175 psig 1034 to 1207 kPa
Wattage (Last 1/3 of cycle)	140 to 185	140 to 185
Amps (Running)	1.1 to 1.6	1.1 to 1.6
Base Voltage	115 VAC	115 VAC

DEFROST SPECIFICATIONS				
Cabinet Size	Thermostat		Heater	
	Cut-in	Cut-out	Watts	Ohms
18' & 21'	25°F -4°C	47°F 8°C	375	35
14', 15' & 17'	25°F -4°C	47°F 8°C	325	41

Mechanical Timer - Defrost 30 Minutes Every 10 Hours of Compressor Run Time
Electronic Timer (ADC) Defrost Up To 24 Minutes Every 6 - 72 Hours of Compressor Run Time

CONDENSER FAN MOTOR		
Watts	RPM	Amps
2.3	1100 CW Opposite Shaft	.15 Running

ICE MAKER SPECIFICATIONS		
Electrical	115 Volts	60 Hertz
Thermostat	Opens at 48°F (9°C)	Closes at 15°F (-9°C)
Heater Wattage	165	

ICE MAKER CONNECTOR PLUG CONNECTIONS		
Wire Number	Wire Color	Connects to:
1	Green/Yellow	Ground
2	Yellow	Water Valve
3	Black	Line
4	Lt. Blue	Neutral

SERVICE DATA SHEET

STANDARD - AUTOMATIC
DEFROST TOP FREEZER
MODELS (R134a)

P/N: 240379006
(12594303)

IMPORTANT SAFETY NOTICE

The information provided herein is designed to assist qualified repair personnel only. Untrained persons should not attempt to make repairs due to the possibility of electrical shock. Disconnect power cord before servicing.

IMPORTANT

If any green grounding wires are moved during servicing, they must be returned to their original position and properly secured.

CAUTION: All electrical parts and wiring must be shielded from torch flame. Do not allow torch to contact insulation; it will char at 200°F and flash ignite (burn) at 500°F. Excessive heat will distort the plastic liner.

NOTE: This product comes equipped with an Electronic Defrost Control. To initiate defrost, depress the fresh food light switch 5 times in 6 seconds (light bulb must be working). To terminate defrost, depress the fresh food light switch 5 times in 6 seconds.

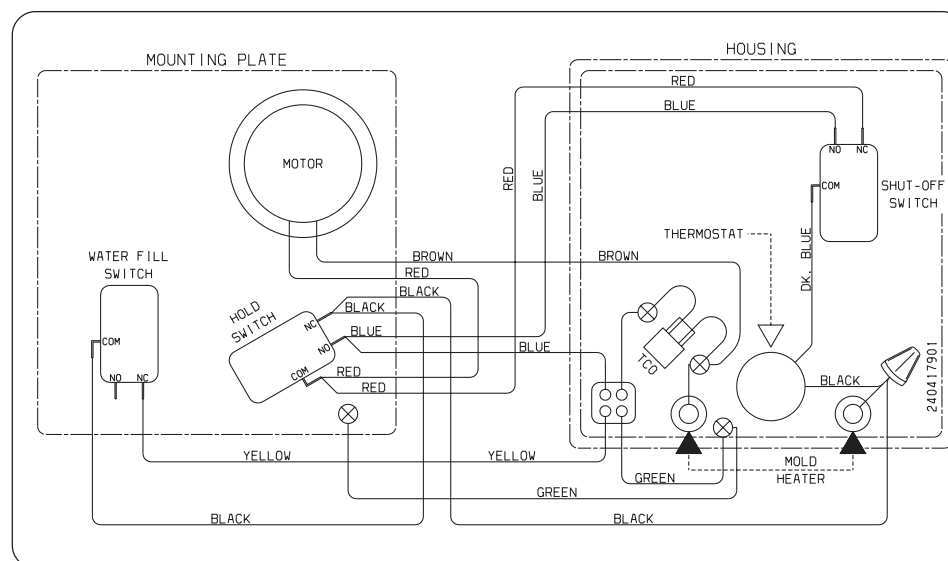

ICE MAKER INFORMATION

Test Cycling

Remove cover by inserting screwdriver in notch at bottom and prying cover from housing. Use screwdriver to rotate motor gear counterclockwise until holding switch circuit is completed. All components of ice maker should function to complete the cycle.

Water Fill Volume

The water fill adjustment screw will change the fill time. One full turn is equal to 20cc (.68 oz.). The correct fill is 102 to 130cc (3.4 to 4.3 oz.). When a water valve is replaced, the fill volume must be checked.

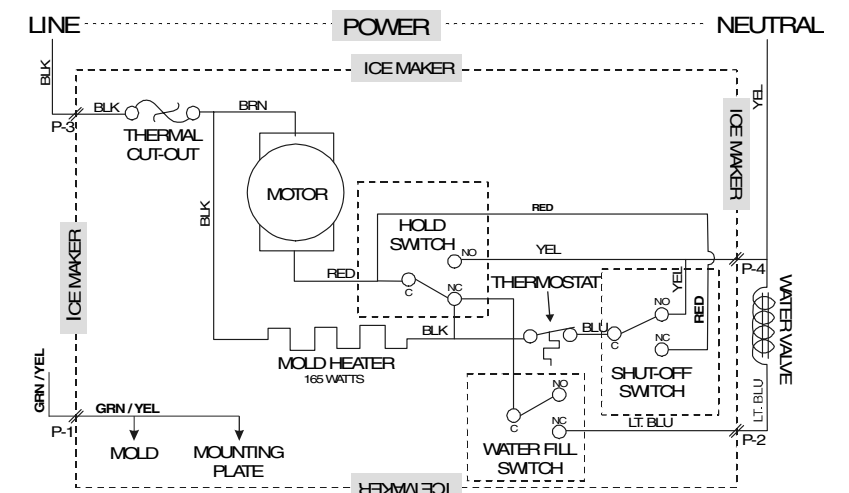
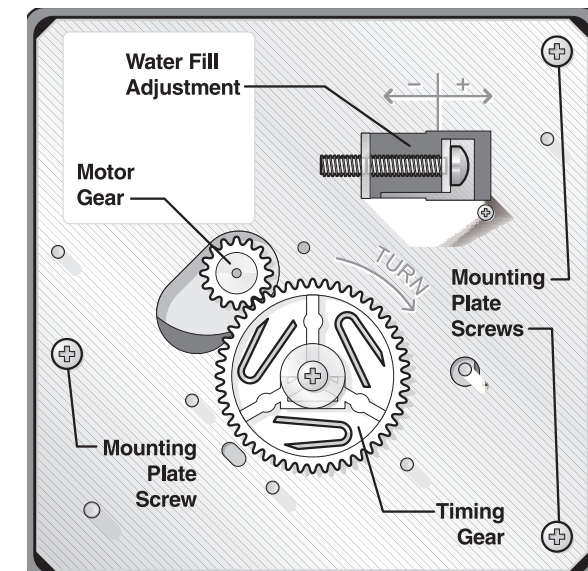

Pictorial Schematic

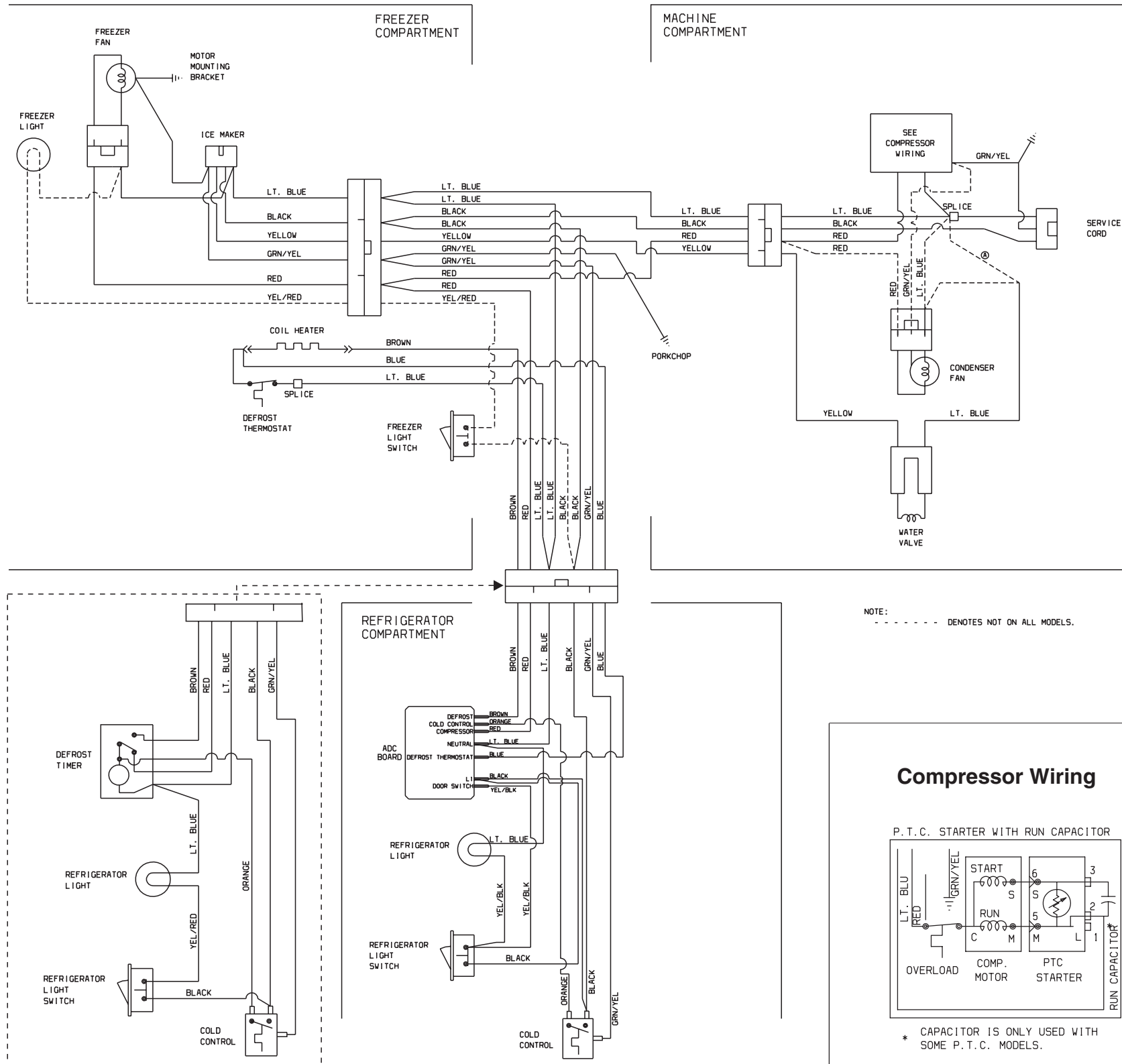

Ladder Schematic

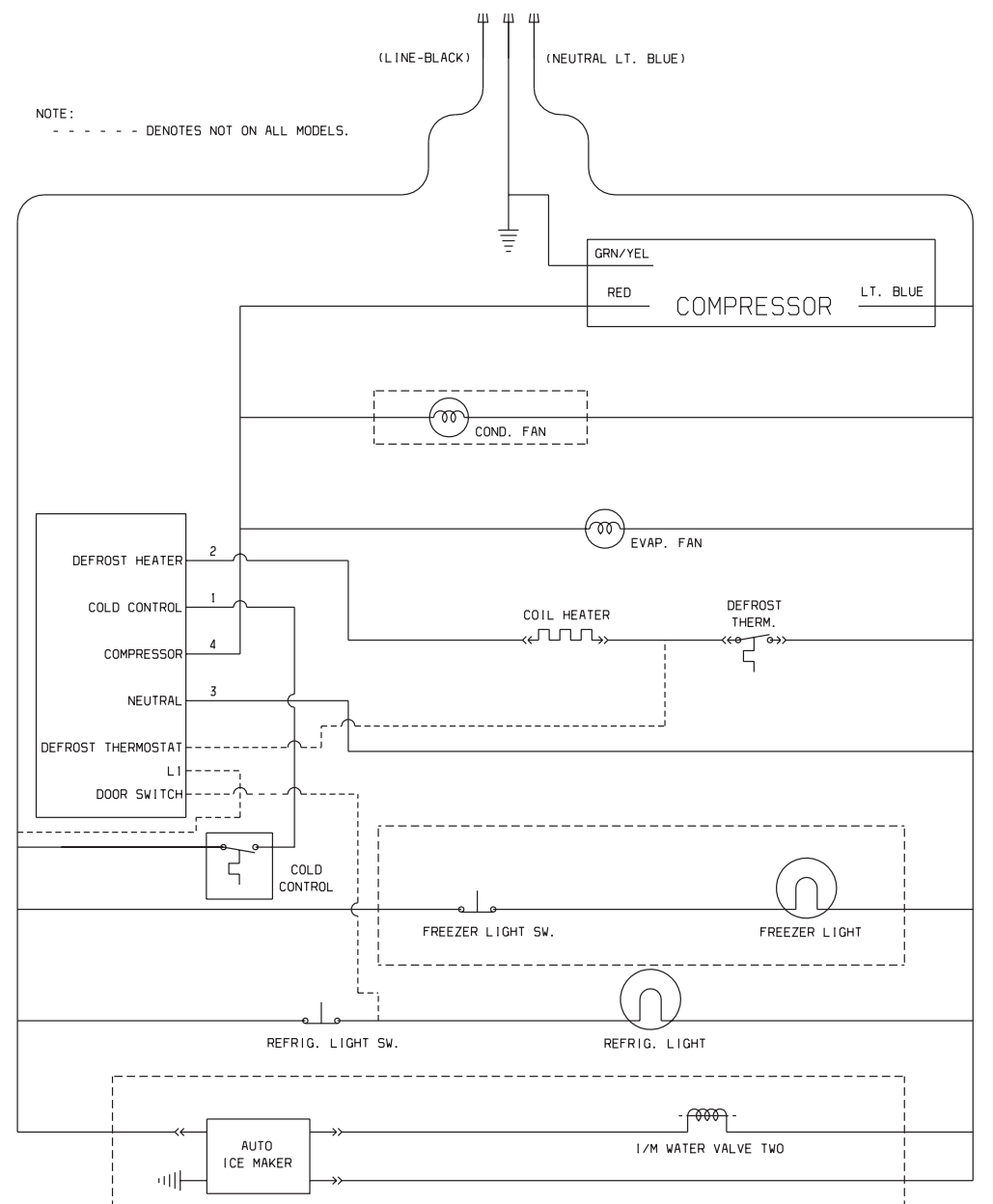

Compressor Wiring

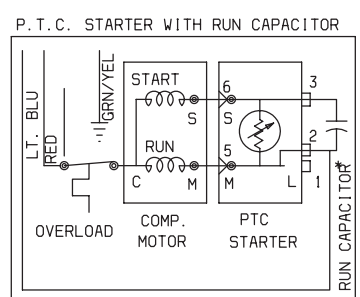

* CAPACITOR IS ONLY USED WITH SOME P.T.C. MODELS.

PERFORMANCE DATA NO LOAD AND NO DOOR OPENINGS AT MID-POINT CONTROL SETTING		
Type A With Run Capacitor	65°F (18°C) Ambient	90°F (32°C) Ambient
Operating Time	25 to 35%	45 to 55%
Freezer Temperature	2° to 8°F -17° to -13°C	0° to 5°F -18° to -15°C
Refrigerature Temperature	35° to 40°F 2° to 4°C	35° to 40°F 2° to 4°C
Low Side Pressure (cut-in)	8 to 16 psig 55 to 110 kPa	8 to 16 psig 55 to 110 kPa
Low Side Pressure (cut-out)	1 to 4 psig 7 to 28 kPa	1 to 4 psig 7 to 28 kPa
High Side Pressure (Last 1/3 of cycle)	110 to 120 psig 758 to 827 kPa	150 to 175 psig 1034 to 1207 kPa
Wattage (Last 1/3 of cycle)	140 to 185	140 to 185
Amps (Running)	1.1 to 1.6	1.1 to 1.6
Base Voltage	115 VAC	115 VAC

DEFROST SPECIFICATIONS				
Cabinet Size	Thermostat		Heater	
	Cut-in	Cut-out	Watts	Ohms
18' & 21'	25°F -4°C	47°F 8°C	375	35
14', 15' & 17'	25°F -4°C	47°F 8°C	325	41

Mechanical Timer - Defrost 30 Minutes Every 10 Hours of Compressor Run Time
Electronic Timer (ADC) Defrost Up To 24 Minutes Every 6 - 72 Hours of Compressor Run Time

CONDENSER FAN MOTOR		
Watts	RPM	Amps
2.3	1100 CW Opposite Shaft	.15 Running

ICE MAKER SPECIFICATIONS		
Electrical	115 Volts	60 Hertz
Thermostat	Opens at 48°F (9°C)	Closes at 15°F (-9°C)
Heater Wattage	165	

ICE MAKER CONNECTOR PLUG CONNECTIONS		
Wire Number	Wire Color	Connects to:
1	Green/Yellow	Ground
2	Yellow	Water Valve
3	Black	Line
4	Lt. Blue	Neutral

SERVICE DATA SHEET

STANDARD - AUTOMATIC
DEFROST TOP FREEZER
MODELS (R134a)

P/N: 240379007

IMPORTANT SAFETY NOTICE

The information provided herein is designed to assist qualified repair personnel only. Untrained persons should not attempt to make repairs due to the possibility of electrical shock. Disconnect power cord before servicing.

IMPORTANT

If any green grounding wires are moved during servicing, they must be returned to their original position and properly secured.

CAUTION: All electrical parts and wiring must be shielded from torch flame. Do not allow torch to contact insulation; it will char at 200°F and flash ignite (burn) at 500°F. Excessive heat will distort the plastic liner.

NOTE: This product comes equipped with an Electronic Defrost Control. To initiate defrost, depress the fresh food light switch 5 times in 6 seconds (light bulb must be working). To terminate defrost, depress the fresh food light switch 5 times in 6 seconds.

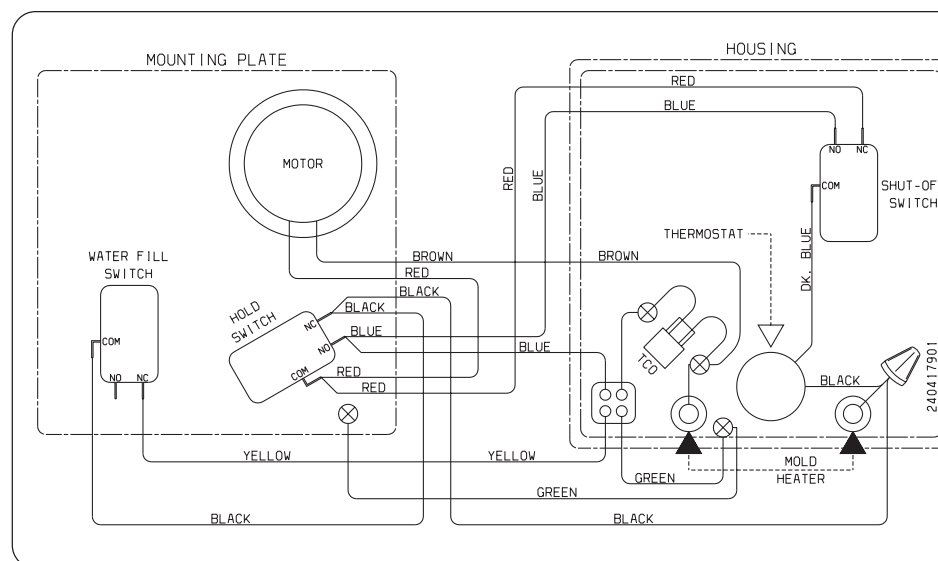

ICE MAKER INFORMATION

Test Cycling

Remove cover by inserting screwdriver in notch at bottom and prying cover from housing. Use screwdriver to rotate motor gear counterclockwise until holding switch circuit is completed. All components of ice maker should function to complete the cycle.

Water Fill Volume

The water fill adjustment screw will change the fill time. One full turn is equal to 20cc (.68 oz.). The correct fill is 102 to 130cc (3.4 to 4.3 oz.). When a water valve is replaced, the fill volume must be checked.

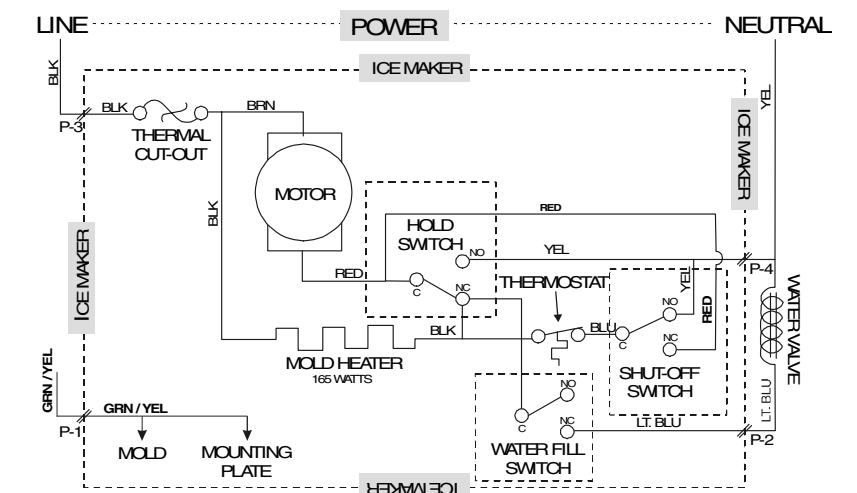
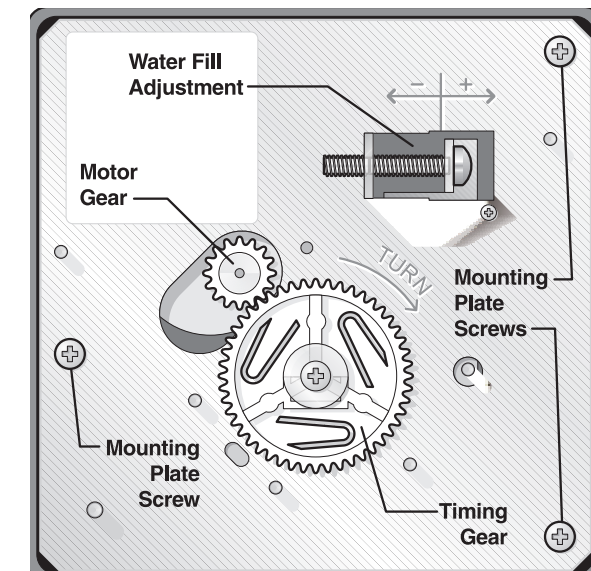

Pictorial Schematic

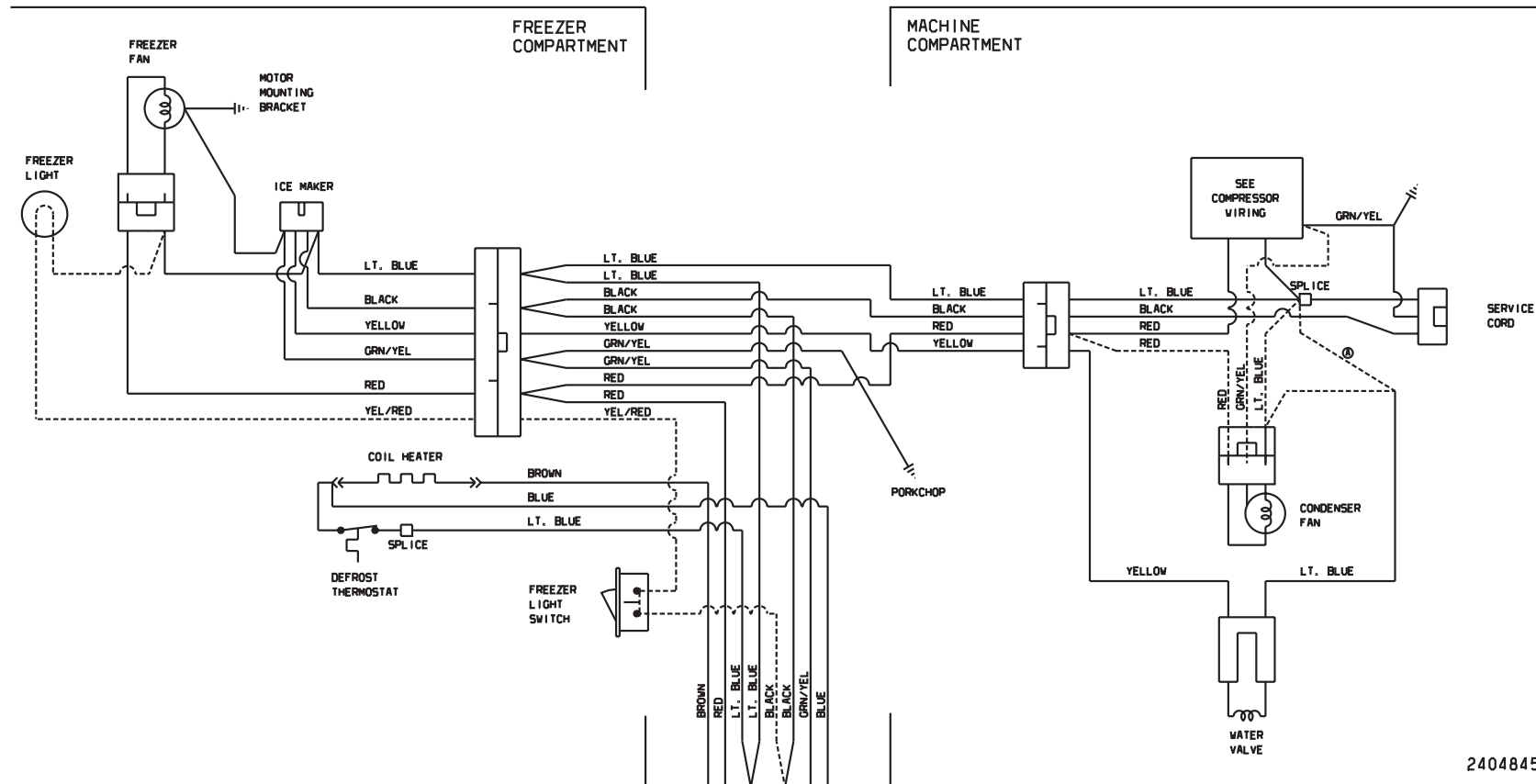

NOTE: - - - - DENOTES NOT ON ALL MODELS.

Compressor Wiring

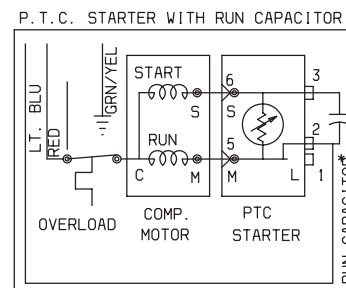

* CAPACITOR IS ONLY USED WITH SOME P.T.C. MODELS.

Ladder Schematic

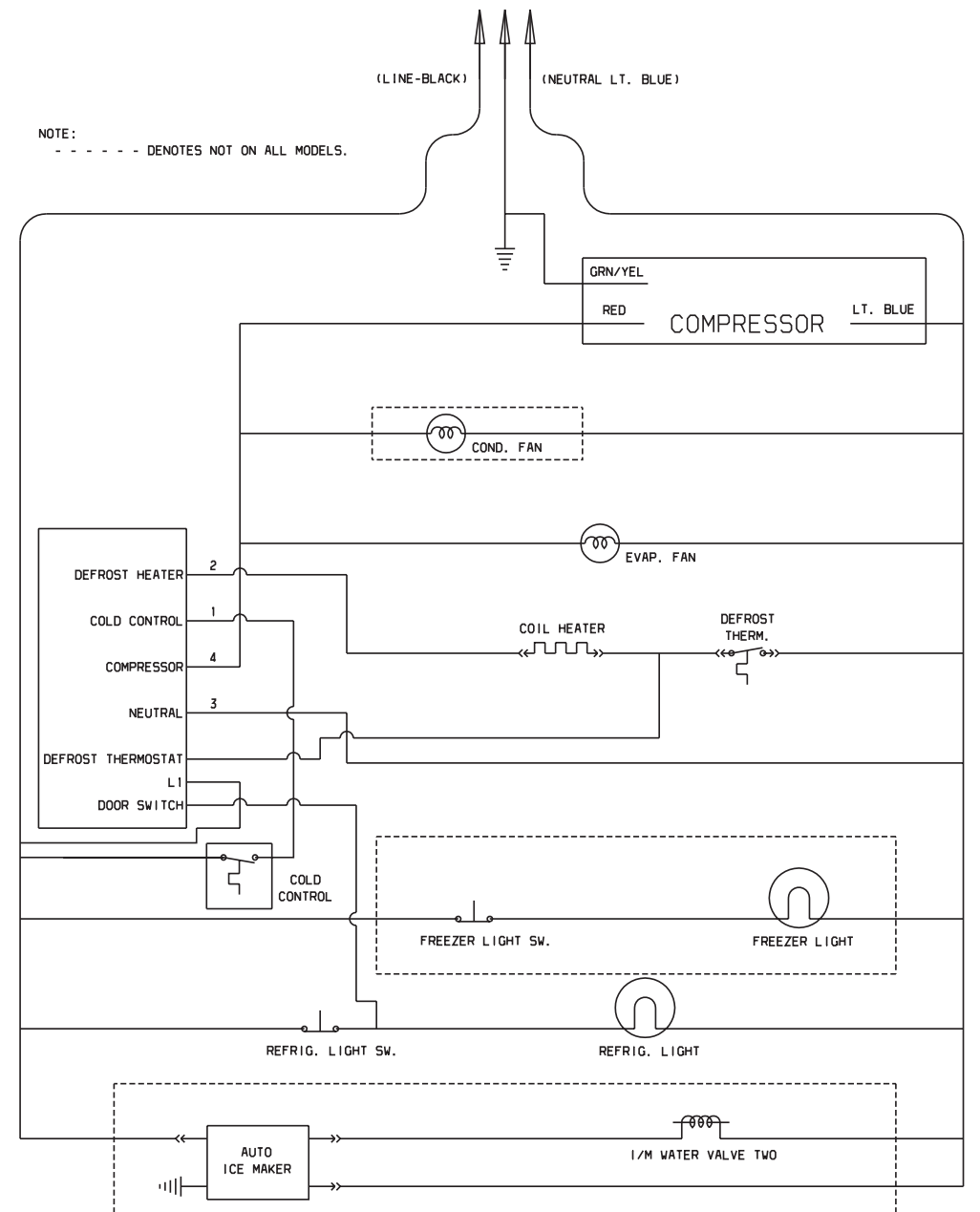

PERFORMANCE DATA NO LOAD AND NO DOOR OPENINGS AT MID-POINT CONTROL SETTING		
Type A With Run Capacitor	65°F (18°C) Ambient	90°F (32°C) Ambient
Operating Time	25 to 35%	45 to 55%
Freezer Temperature	2° to 8°F -17° to -13°C	0° to 5°F -18° to -15°C
Refrigerature Temperature	35° to 40°F 2° to 4°C	35° to 40°F 2° to 4°C
Low Side Pressure (cut-in)	8 to 16 psig 55 to 110 kPa	8 to 16 psig 55 to 110 kPa
Low Side Pressure (cut-out)	1 to 4 psig 7 to 28 kPa	1 to 4 psig 7 to 28 kPa
High Side Pressure (Last 1/3 of cycle)	110 to 120 psig 758 to 827 kPa	150 to 175 psig 1034 to 1207 kPa
Wattage (Last 1/3 of cycle)	140 to 185	140 to 185
Amps (Running)	1.1 to 1.6	1.1 to 1.6
Base Voltage	115 VAC	115 VAC

DEFROST SPECIFICATIONS				
Cabinet Size	Thermostat		Heater	
	Cut-in	Cut-out	Watts	Ohms
18' & 21'	25°F -4°C	47°F 8°C	375	35
14', 15' & 17'	25°F -4°C	47°F 8°C	325	41

Mechanical Timer - Defrost 30 Minutes Every 10 Hours of Compressor Run Time
Electronic Timer (ADC) Defrost Up To 24 Minutes Every 6 - 72 Hours of Compressor Run Time

CONDENSER FAN MOTOR		
Watts	RPM	Amps
2.3	1100 CW Opposite Shaft	.15 Running

ICE MAKER SPECIFICATIONS		
Electrical	115 Volts	60 Hertz
Thermostat	Opens at 48°F (9°C)	Closes at 15°F (-9°C)
Heater Wattage	165	

ICE MAKER CONNECTOR PLUG CONNECTIONS		
Wire Number	Wire Color	Connects to:
1	Green/Yellow	Ground
2	Yellow	Water Valve
3	Black	Line
4	Lt. Blue	Neutral

SERVICE DATA SHEET

STANDARD - AUTOMATIC
DEFROST TOP FREEZER
MODELS (R134a)

P/N: 240379009

IMPORTANT SAFETY NOTICE

The information provided herein is designed to assist qualified repair personnel only. Untrained persons should not attempt to make repairs due to the possibility of electrical shock. Disconnect power cord before servicing.

IMPORTANT

If any green grounding wires are moved during servicing, they must be returned to their original position and properly secured.

CAUTION: All electrical parts and wiring must be shielded from torch flame. Do not allow torch to contact insulation; it will char at 200°F and flash ignite (burn) at 500°F. Excessive heat will distort the plastic liner.

NOTE: This product comes equipped with an Electronic Defrost Control. To initiate defrost, depress the fresh food light switch 5 times in 6 seconds (light bulb must be working). To terminate defrost, depress the fresh food light switch 5 times in 6 seconds.

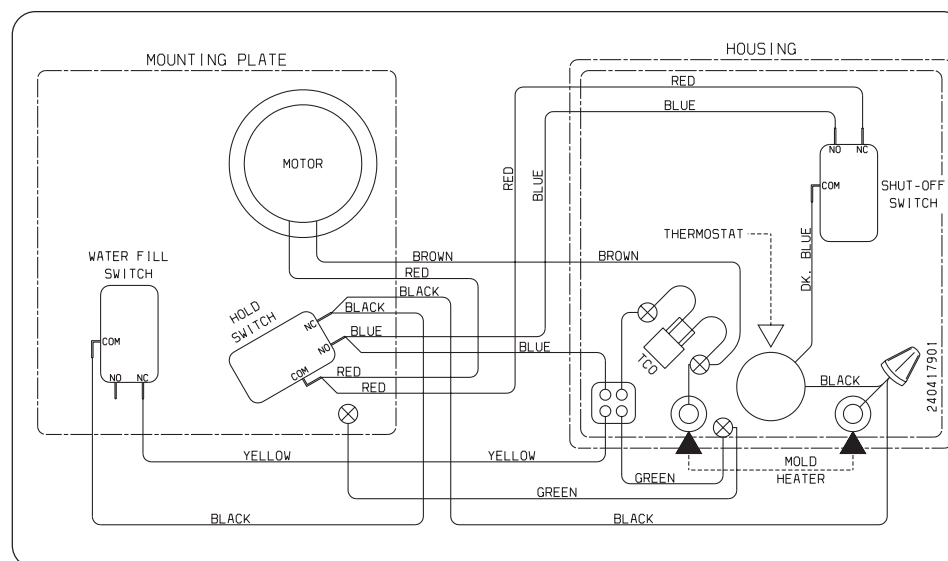

ICE MAKER INFORMATION

Test Cycling

Remove cover by inserting screwdriver in notch at bottom and prying cover from housing. Use screwdriver to rotate motor gear counterclockwise until holding switch circuit is completed. All components of ice maker should function to complete the cycle.

Water Fill Volume

The water fill adjustment screw will change the fill time. One full turn is equal to 20cc (.68 oz.). The correct fill is 102 to 130cc (3.4 to 4.3 oz.). When a water valve is replaced, the fill volume must be checked.

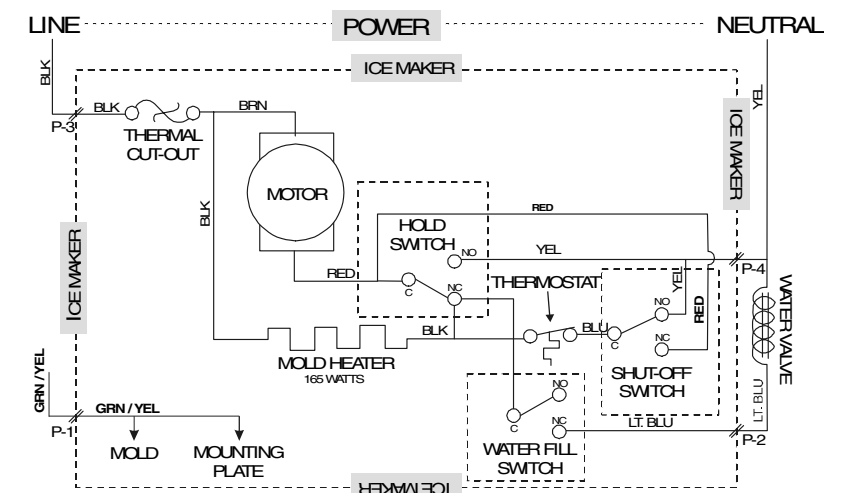
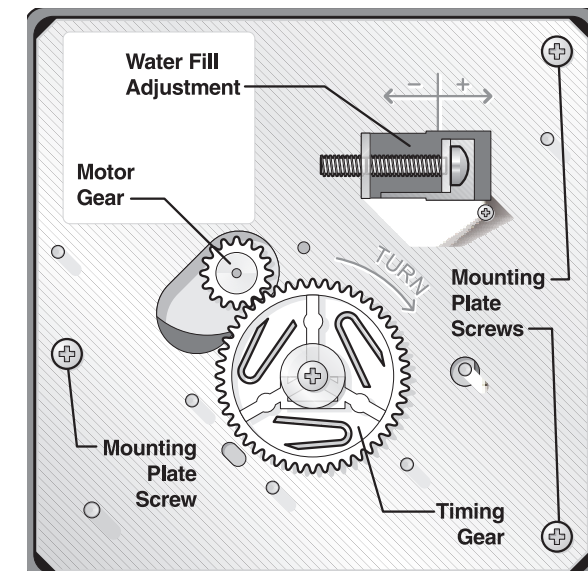

Pictorial Schematic

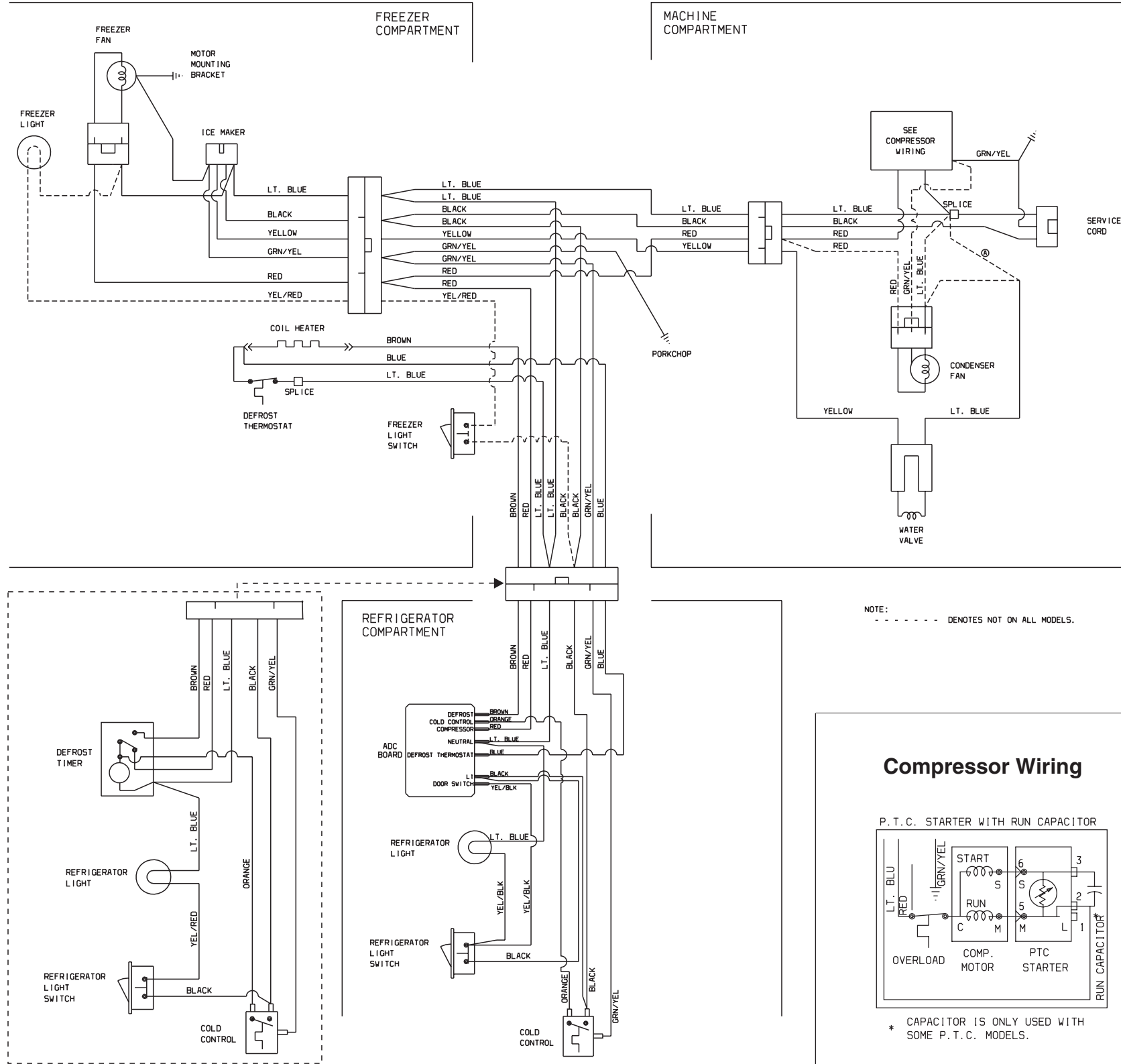

Ladder Schematic

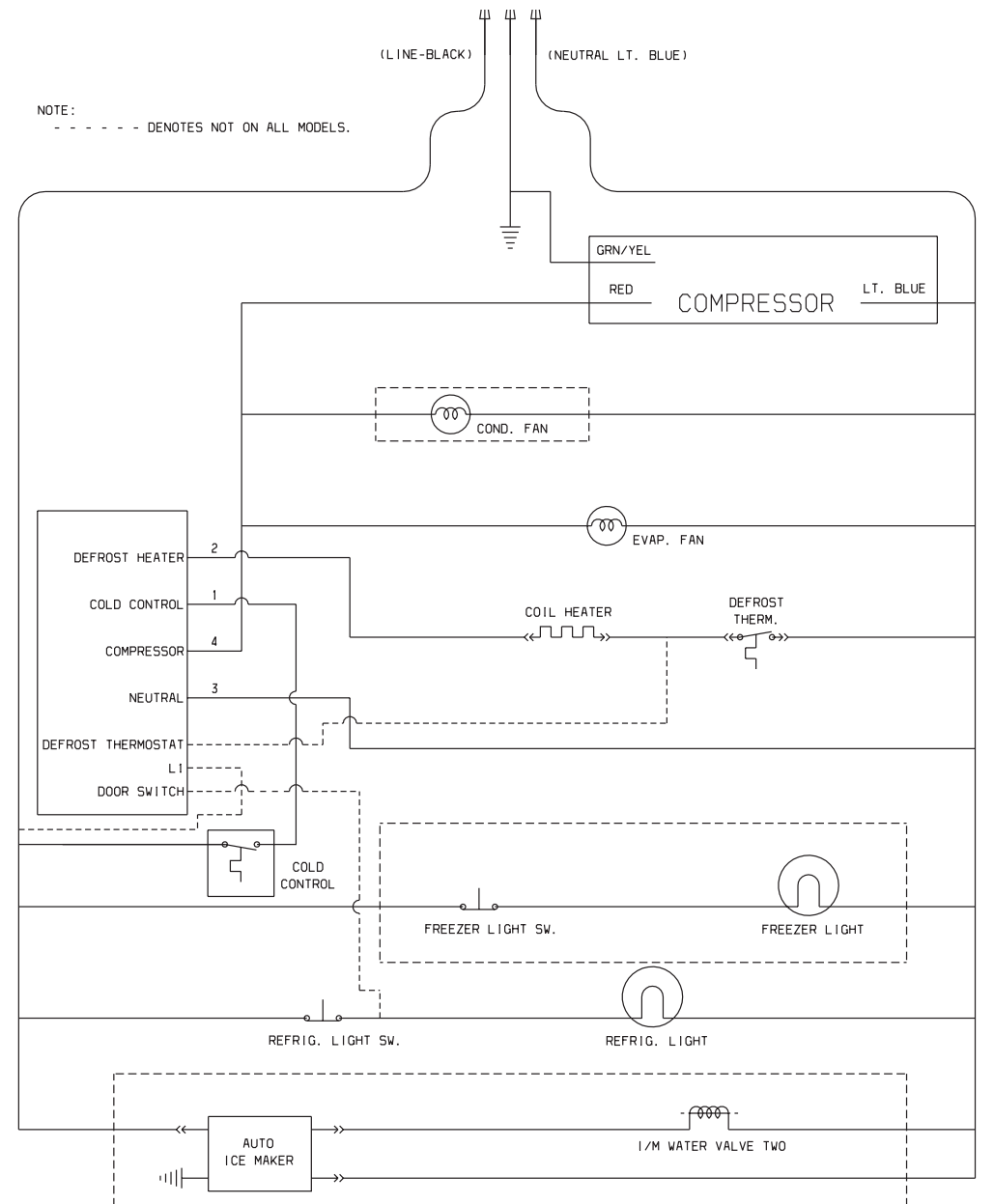

Compressor Wiring

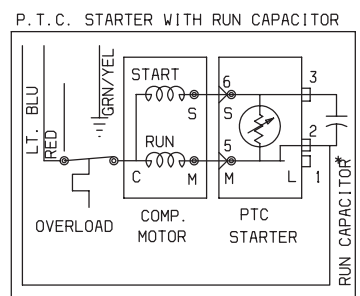

* CAPACITOR IS ONLY USED WITH SOME P.T.C. MODELS.

PERFORMANCE DATA NO LOAD AND NO DOOR OPENINGS AT MID-POINT CONTROL SETTING				
Type A With Run/Start Capacitor	65°F (18°C) Ambient	90°F (32°C) Ambient		
Operating Time	32 to 40%	55 to 65%		
Freezer Temperature	0° to 4°F -18° to -16°C	-1° to 3°F -18° to -16°C		
Refrigerator Temperature	34° to 39°F 1° to 4°C	34° to 39°F 1° to 4°C		
Low Side Pressure (cut-in)	5 to 12 psig 34 to 83 kPa	5 to 12 psig 34 to 83 kPa		
Low Side Pressure (cut-out)	-2 to 2 psig -14 to 14 kPa	-2 to 2 psig -14 to 14 kPa		
High Side Pressure (Last 1/3 of cycle)	90 to 115 psig 621 to 793 kPa	130 to 155 psig 896 to 1069 kPa		
Wattage (Last 1/3 of cycle)	120 to 150	130 to 160		
Amps (Running)	1.2 to 1.5	1.2 to 1.5		
Base Voltage	115 VAC	115 VAC		
DEFROST SPECIFICATIONS				
Cabinet Size	Thermostat		Heater	
	Cut-in	Cut-out	Watts	Ohms
23' & 26'	25°F -4°C	47°F 8°C	450	30
Electronic Timer - (ADC) Defrost 24 minutes every 6 to 72 hours of compressor run time.				
CONDENSER FAN MOTOR				
Watts	RPM	Amps		
7	1100 CW Opposite Shaft	.1 Running		
ICE MAKER SPECIFICATIONS				
Electrical	115 Volts	60 Hertz		
Thermostat	Opens at 48°F (9°C)	Closes at 15°F (-9°C)		
Heater Wattage	165			

ICE MAKER CONNECTOR PLUG CONNECTIONS		
Wire Number	Wire Color	Connects to:
1	Green/Yellow	Ground
2	Yellow	Water Valve
3	Black	Line
4	Lt. Blue	Neutral

SERVICE DATA SHEET - 240389604

R134a

ICE & WATER - AUTOMATIC DEFROST SIDE BY SIDE MODELS

IMPORTANT SAFETY NOTICE

The information provided herein is designed to assist qualified repair personnel only. Untrained persons should not attempt to make repairs due to the possibility of electrical shock. Disconnect power cord before servicing.

IMPORTANT

If any green grounding wires are moved during servicing, they must be returned to their original position and properly secured.

CAUTION: All electrical parts and wiring must be shielded from torch flame. Do not allow torch to contact insulation; it will char at 200°F and flash ignite (burn) at 500°F. Excessive heat will distort the plastic liner.

NOTE: This product comes equipped with an Electronic Defrost Control. To initiate defrost, depress the fresh food light switch 5 times in 6 seconds (light bulb must be working). To terminate defrost, depress the fresh food light switch 5 times in 6 seconds.

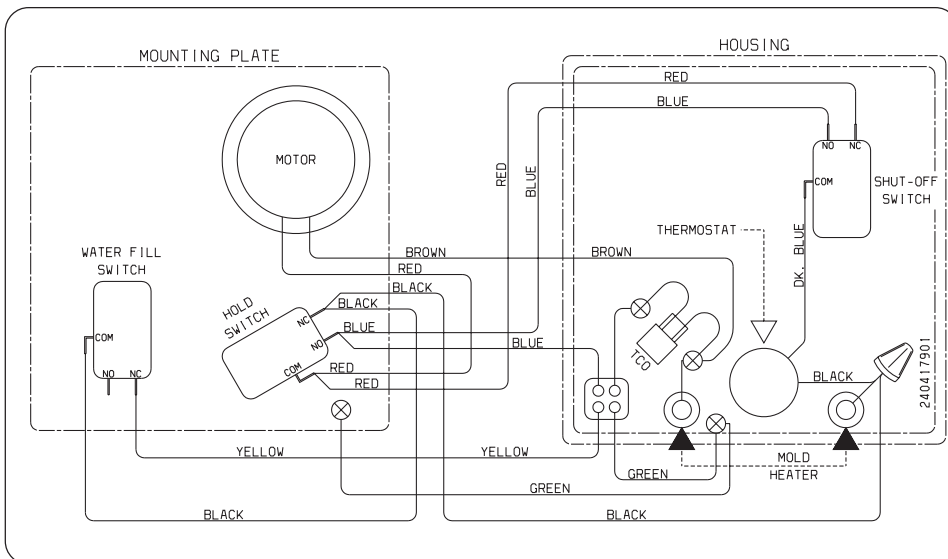

ICE MAKER INFORMATION

Test Cycling

Remove cover by inserting screwdriver in notch at bottom and prying cover from housing. Use screwdriver to rotate motor gear counterclockwise until holding switch circuit is completed. All components of ice maker should function to complete the cycle.

Water Fill Volume

The water fill adjustment screw will change the fill time. One full turn is equal to 20cc (.68 oz.). The correct fill is 102 to 130cc (3.4 to 4.3 oz.). When a water valve is replaced, the fill volume must be checked.

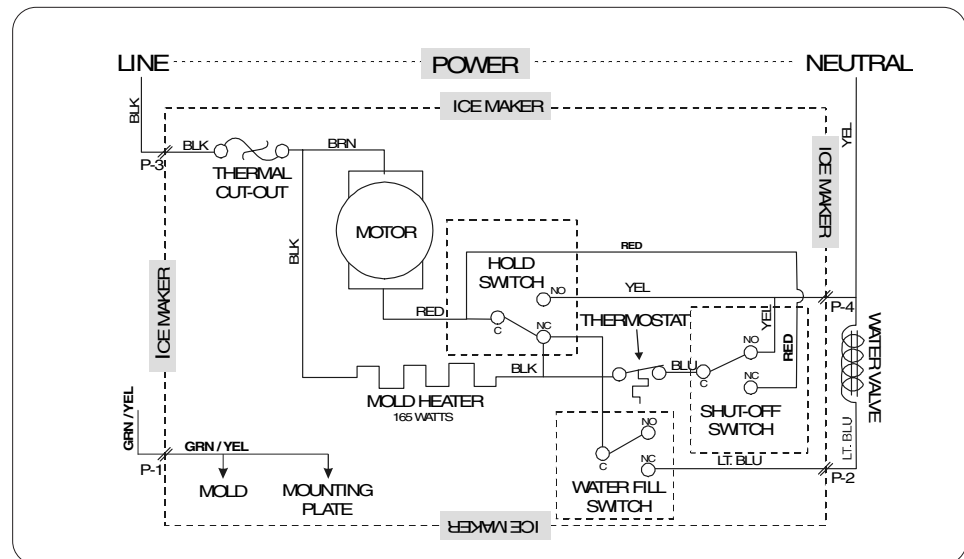

Pictorial Schematic

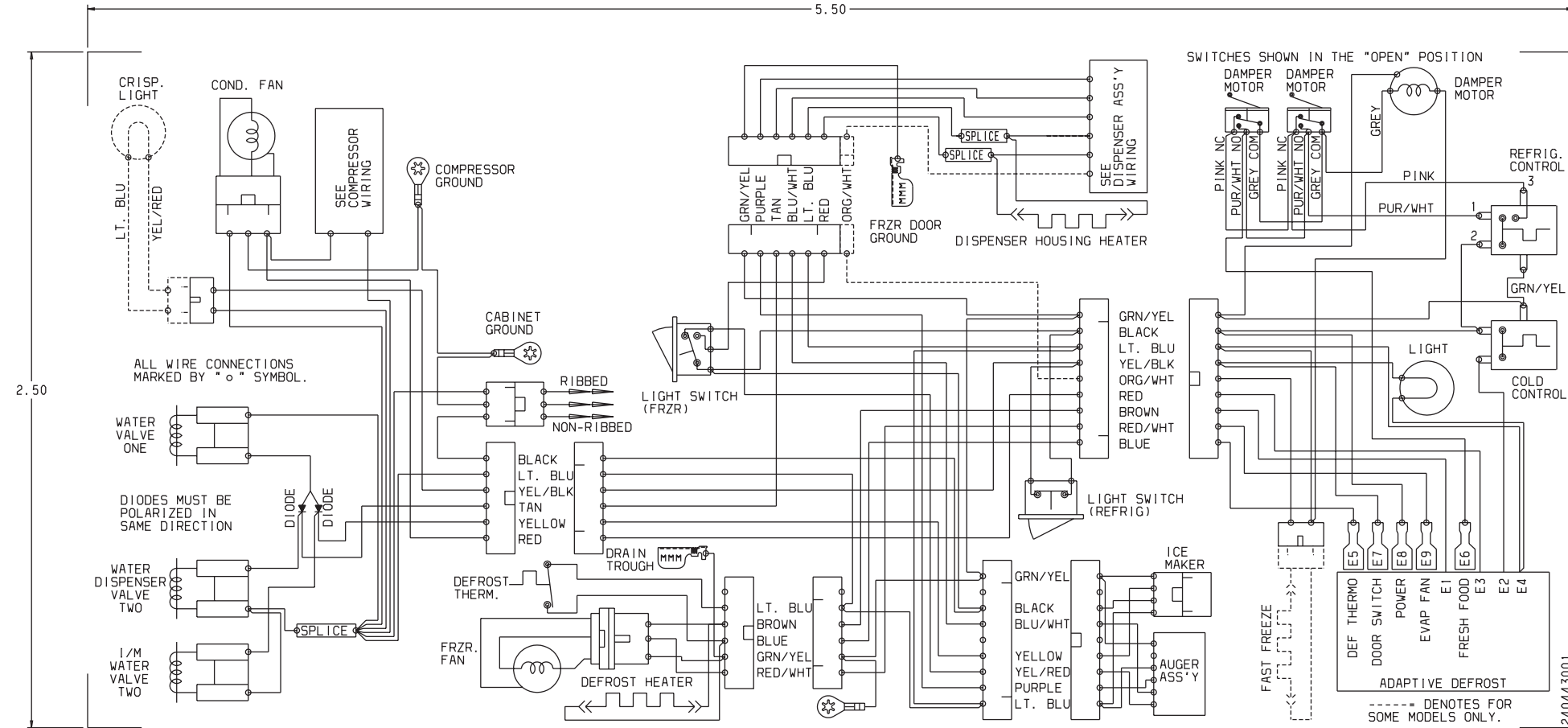

Ladder Schematic

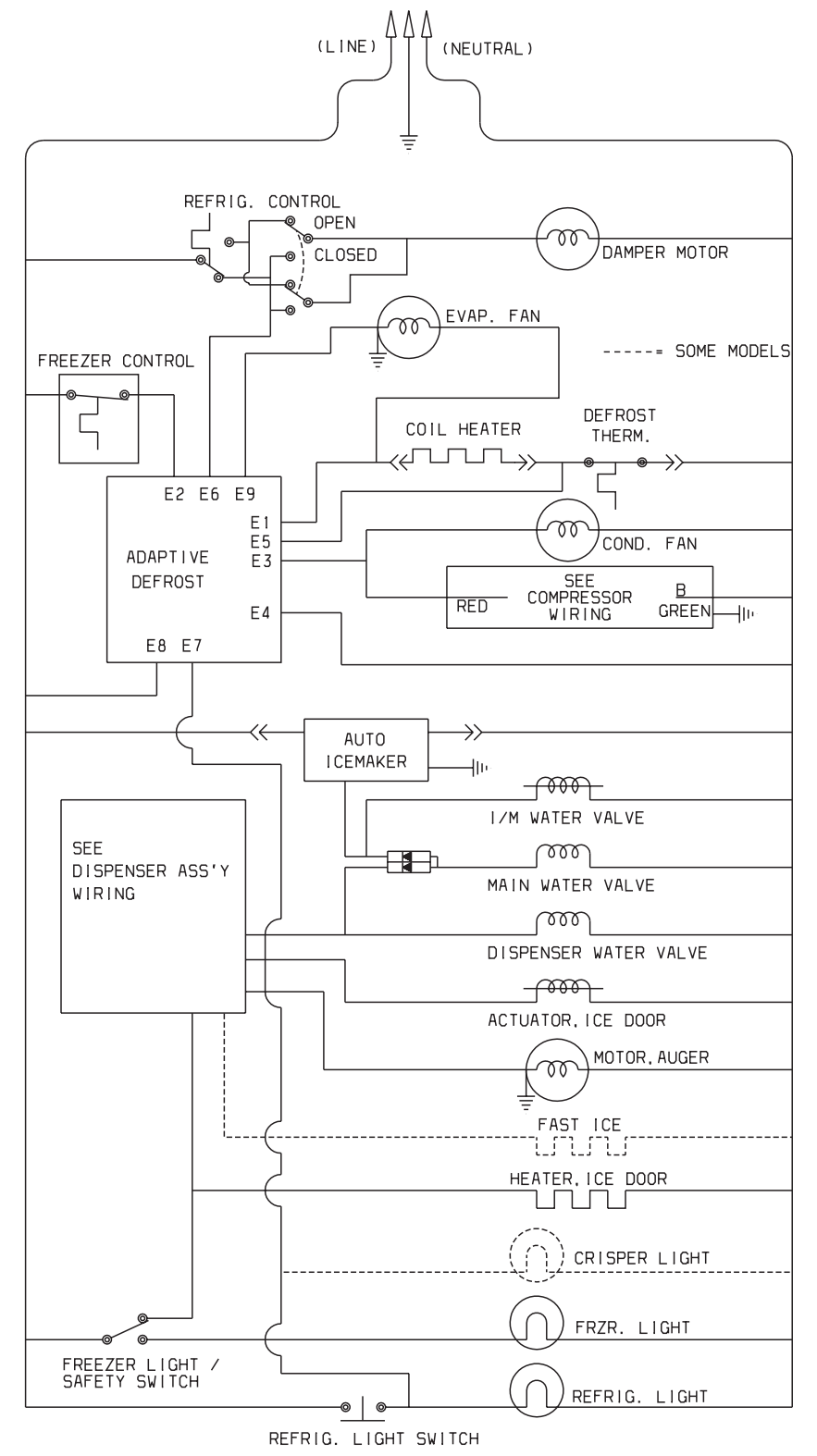

Electro-Mechanical Dispenser

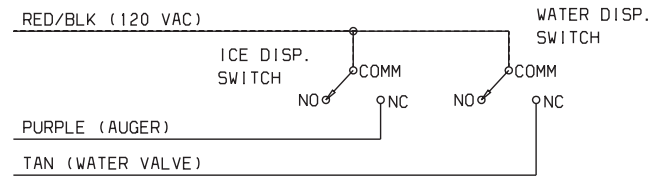

Compressor Wiring

P.T.C. STARTER WITH RUN CAPACITOR

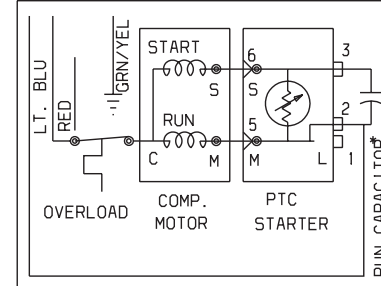

* CAPACITOR IS ONLY USED WITH SOME P.T.C. MODELS.

Electronic Dispenser

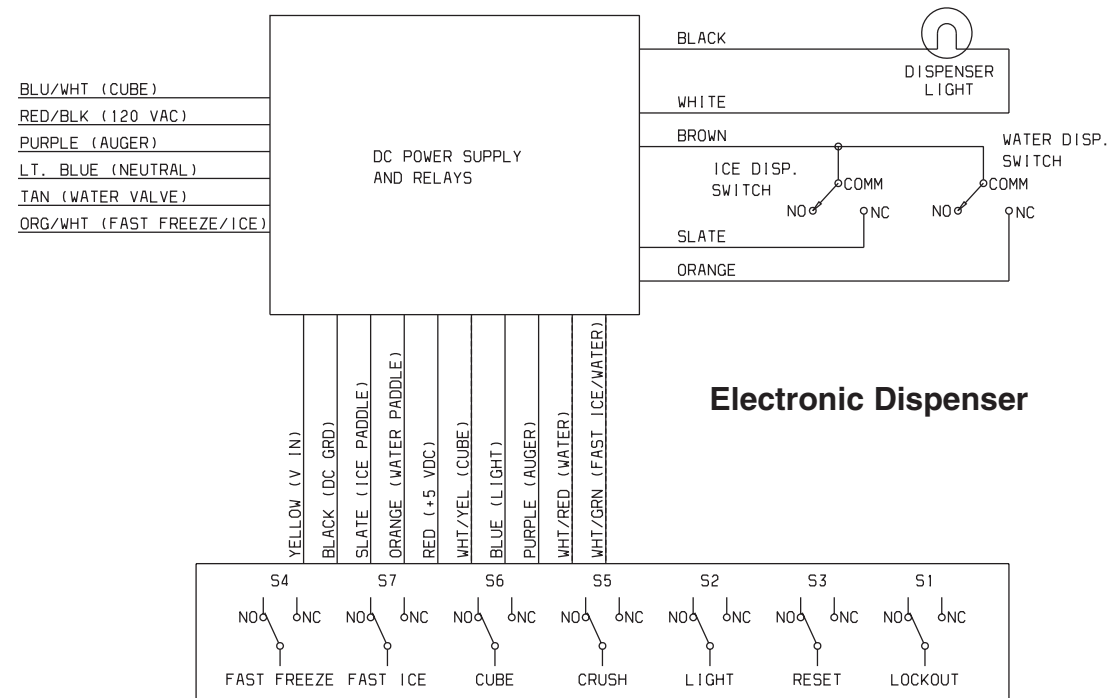

PERFORMANCE DATA NO LOAD AND NO DOOR OPENINGS AT MID-POINT CONTROL SETTING				
Type A With Run/Start Capacitor	65°F (18°C) Ambient	90°F (32°C) Ambient		
Operating Time	32 to 40%	55 to 65%		
Freezer Temperature	0° to 4°F -18° to -16°C	-1° to 3°F -18° to -16°C		
Refrigerator Temperature	34° to 39°F 1° to 4°C	34° to 39°F 1° to 4°C		
Low Side Pressure (cut-in)	5 to 12 psig 34 to 83 kPa	5 to 12 psig 34 to 83 kPa		
Low Side Pressure (cut-out)	-2 to 2 psig -14 to 14 kPa	-2 to 2 psig -14 to 14 kPa		
High Side Pressure (Last 1/3 of cycle)	90 to 115 psig 621 to 793 kPa	130 to 155 psig 896 to 1069 kPa		
Wattage (Last 1/3 of cycle)	120 to 150	130 to 160		
Amps (Running)	1.2 to 1.5	1.2 to 1.5		
Base Voltage	115 VAC	115 VAC		
DEFROST SPECIFICATIONS				
Cabinet Size	Thermostat		Heater	
	Cut-in	Cut-out	Watts	Ohms
23' & 26'	25°F -4°C	47°F 8°C	450	30
Electronic Timer - (ADC) Defrost 24 minutes every 6 to 72 hours of compressor run time.				
CONDENSER FAN MOTOR				
Watts	RPM	Amps		
7	1100 CW Opposite Shaft	.1 Running		
ICE MAKER SPECIFICATIONS				
Electrical	115 Volts	60 Hertz		
Thermostat	Opens at 48°F (9°C)	Closes at 15°F (-9°C)		
Heater Wattage	165			

ICE MAKER CONNECTOR PLUG CONNECTIONS		
Wire Number	Wire Color	Connects to:
1	Green/Yellow	Ground
2	Yellow	Water Valve
3	Black	Line
4	Lt. Blue	Neutral

SERVICE DATA SHEET - 240389605

R134a

ICE & WATER - AUTOMATIC DEFROST SIDE BY SIDE MODELS

IMPORTANT SAFETY NOTICE

The information provided herein is designed to assist qualified repair personnel only. Untrained persons should not attempt to make repairs due to the possibility of electrical shock. Disconnect power cord before servicing.

IMPORTANT

If any green grounding wires are moved during servicing, they must be returned to their original position and properly secured.

CAUTION: All electrical parts and wiring must be shielded from torch flame. Do not allow torch to contact insulation; it will char at 200°F and flash ignite (burn) at 500°F. Excessive heat will distort the plastic liner.

NOTE: This product comes equipped with an Electronic Defrost Control. To initiate defrost, depress the fresh food light switch 5 times in 6 seconds (light bulb must be working). To terminate defrost, depress the fresh food light switch 5 times in 6 seconds.

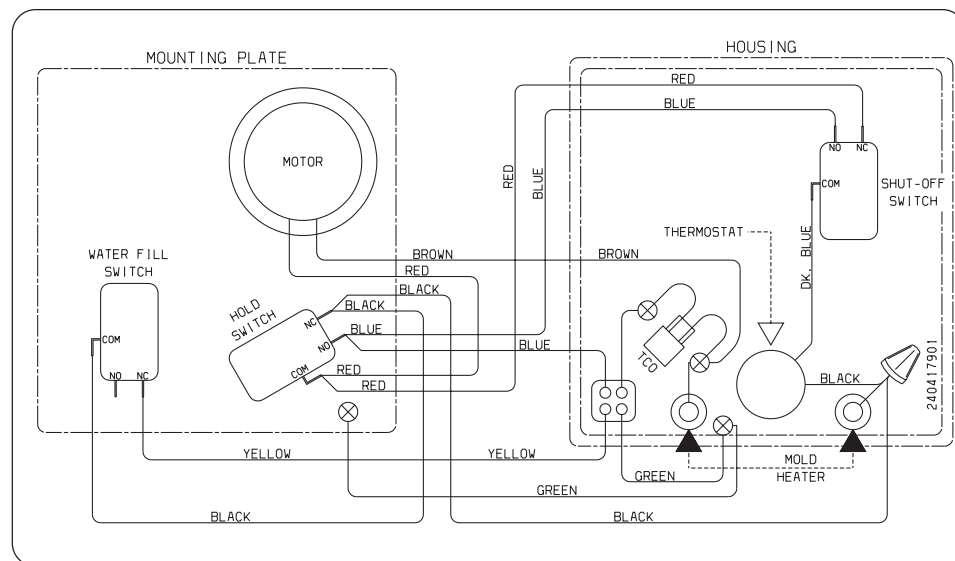

ICE MAKER INFORMATION

Test Cycling

Remove cover by inserting screwdriver in notch at bottom and prying cover from housing. Use screwdriver to rotate motor gear counterclockwise until holding switch circuit is completed. All components of ice maker should function to complete the cycle.

Water Fill Volume

The water fill adjustment screw will change the fill time. One full turn is equal to 20cc (.68 oz.). The correct fill is 102 to 130cc (3.4 to 4.3 oz.). When a water valve is replaced, the fill volume must be checked.

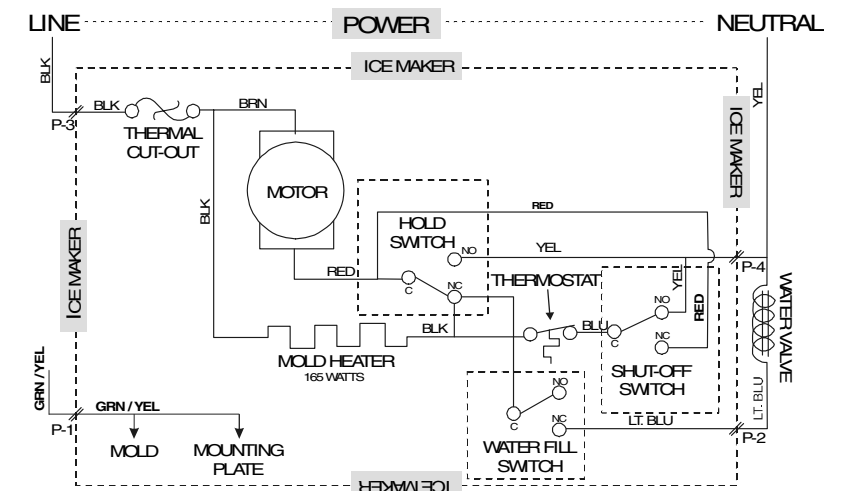
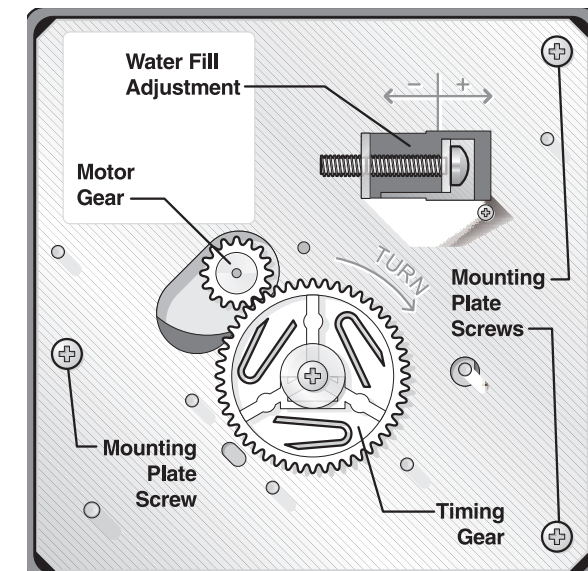

ELECTRONIC DISPENSER

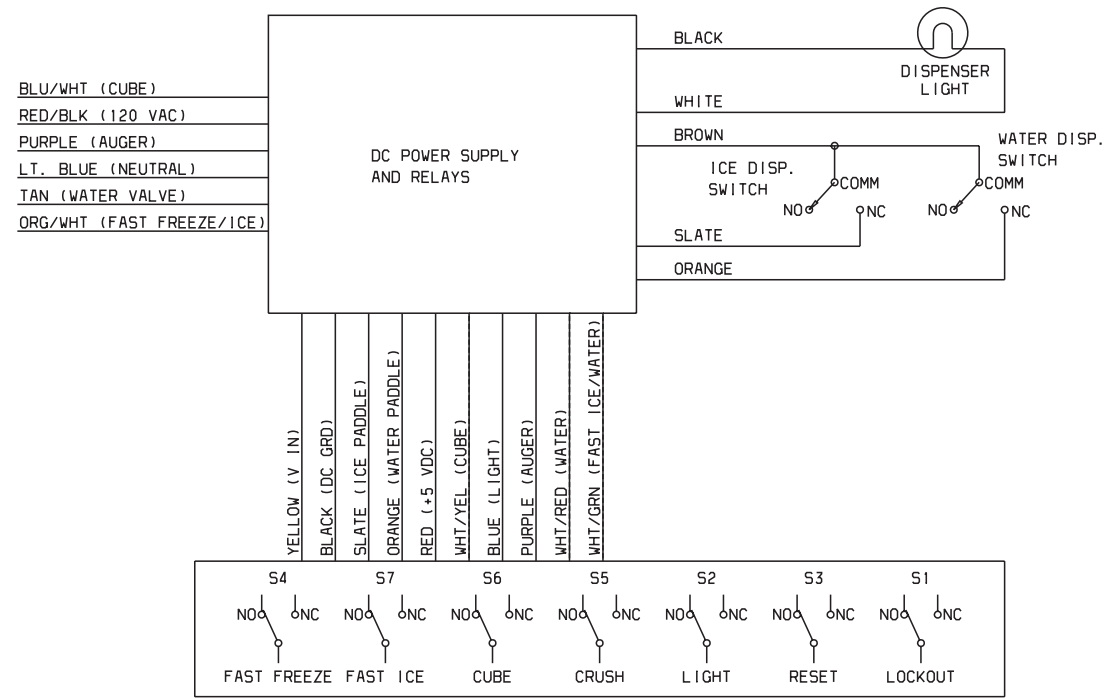

ELECTRO-MECHANICAL DISPENSER

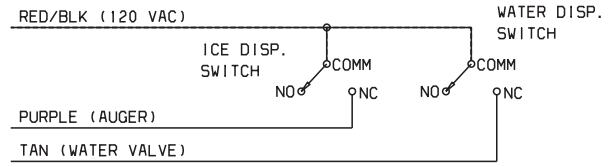

P. T. C. STARTER WITH RUN CAPACITOR

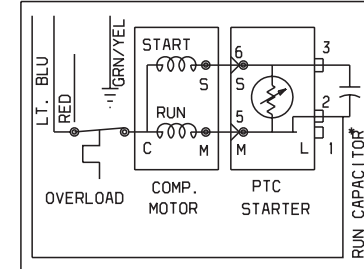

* CAPACITOR IS ONLY USED WITH SOME P. T. C. MODELS.

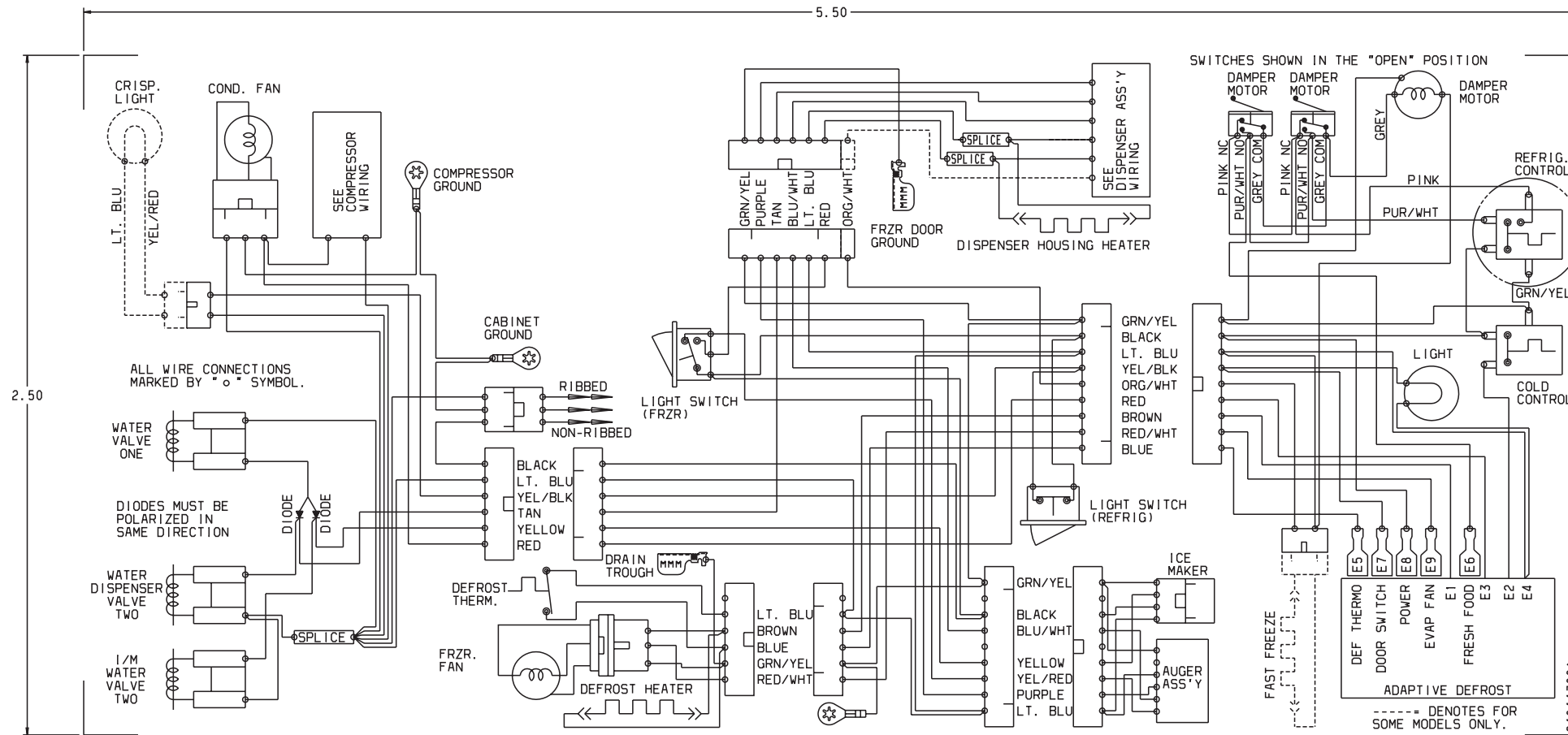

240443001

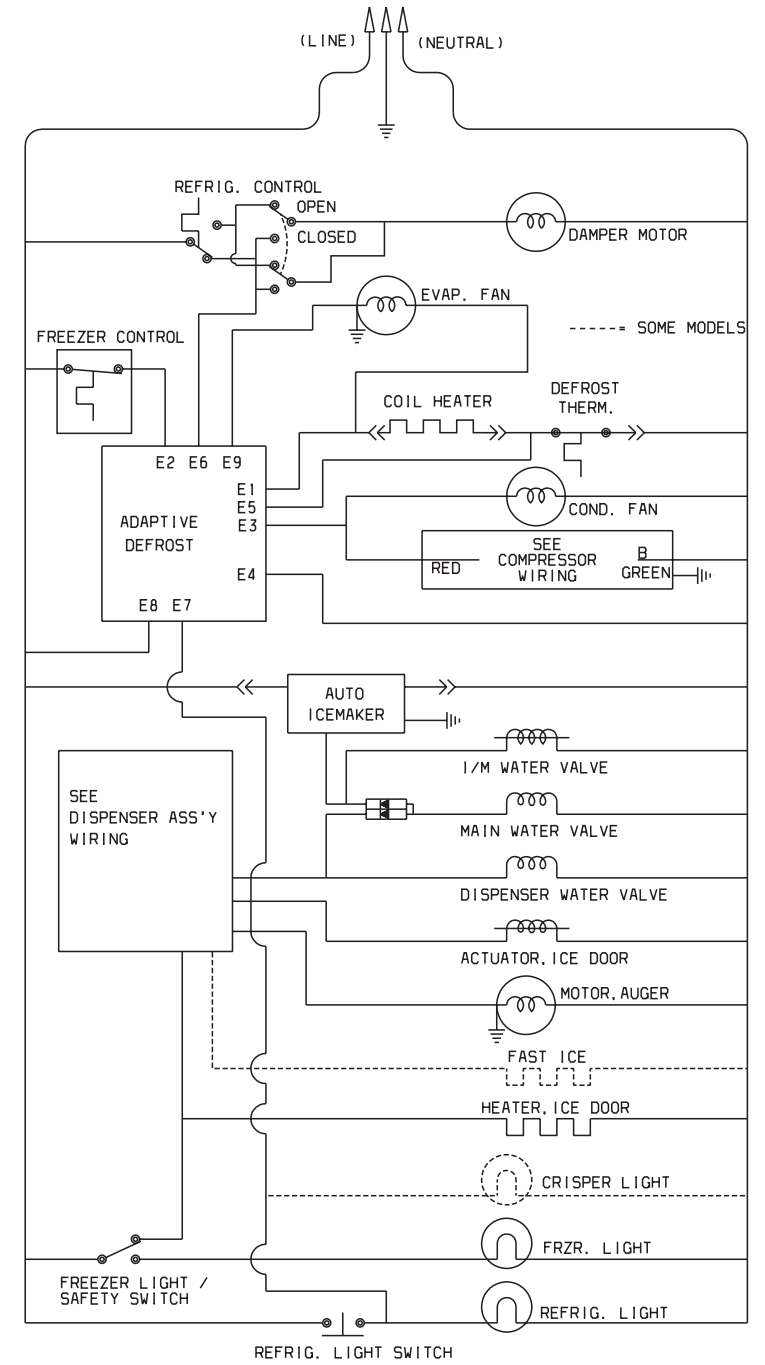

PERFORMANCE DATA NO LOAD AND NO DOOR OPENINGS AT MID-POINT CONTROL SETTING				
Type A With Run/Start Capacitor	65°F (18°C) Ambient	90°F (32°C) Ambient		
Operating Time	32 to 40%	55 to 65%		
Freezer Temperature	0° to 4°F -18° to -16°C	-1° to 3°F -18° to -16°C		
Refrigerator Temperature	34° to 39°F 1° to 4°C	34° to 39°F 1° to 4°C		
Low Side Pressure (cut-in)	5 to 12 psig 34 to 83 kPa	5 to 12 psig 34 to 83 kPa		
Low Side Pressure (cut-out)	-2 to 2 psig -14 to 14 kPa	-2 to 2 psig -14 to 14 kPa		
High Side Pressure (Last 1/3 of cycle)	90 to 115 psig 621 to 793 kPa	130 to 155 psig 896 to 1069 kPa		
Wattage (Last 1/3 of cycle)	120 to 150	130 to 160		
Amps (Running)	1.2 to 1.5	1.2 to 1.5		
Base Voltage	115 VAC	115 VAC		
DEFROST SPECIFICATIONS				
Cabinet Size	Thermostat		Heater	
	Cut-in	Cut-out	Watts	Ohms
23' & 26'	25°F -4°C	47°F 8°C	450	30
Electronic Timer - (ADC) Defrost 24 minutes every 6 to 72 hours of compressor run time.				
CONDENSER FAN MOTOR				
Watts	RPM	Amps		
7	1100 CW Opposite Shaft	.1 Running		
ICE MAKER SPECIFICATIONS				
Electrical	115 Volts	60 Hertz		
Thermostat	Opens at 48°F (9°C)	Closes at 15°F (-9°C)		
Heater Wattage	165			

ICE MAKER CONNECTOR PLUG CONNECTIONS		
Wire Number	Wire Color	Connects to:
1	Green/Yellow	Ground
2	Yellow	Water Valve
3	Black	Line
4	Lt. Blue	Neutral

SERVICE DATA SHEET - 240389606

R134a

ICE & WATER - AUTOMATIC DEFROST SIDE BY SIDE MODELS

IMPORTANT SAFETY NOTICE

The information provided herein is designed to assist qualified repair personnel only. Untrained persons should not attempt to make repairs due to the possibility of electrical shock. Disconnect power cord before servicing.

IMPORTANT

If any green grounding wires are moved during servicing, they must be returned to their original position and properly secured.

CAUTION: All electrical parts and wiring must be shielded from torch flame. Do not allow torch to contact insulation; it will char at 200°F and flash ignite (burn) at 500°F. Excessive heat will distort the plastic liner.

NOTE: This product comes equipped with an Electronic Defrost Control. To initiate defrost, depress the fresh food light switch 5 times in 6 seconds (light bulb must be working). To terminate defrost, depress the fresh food light switch 5 times in 6 seconds.

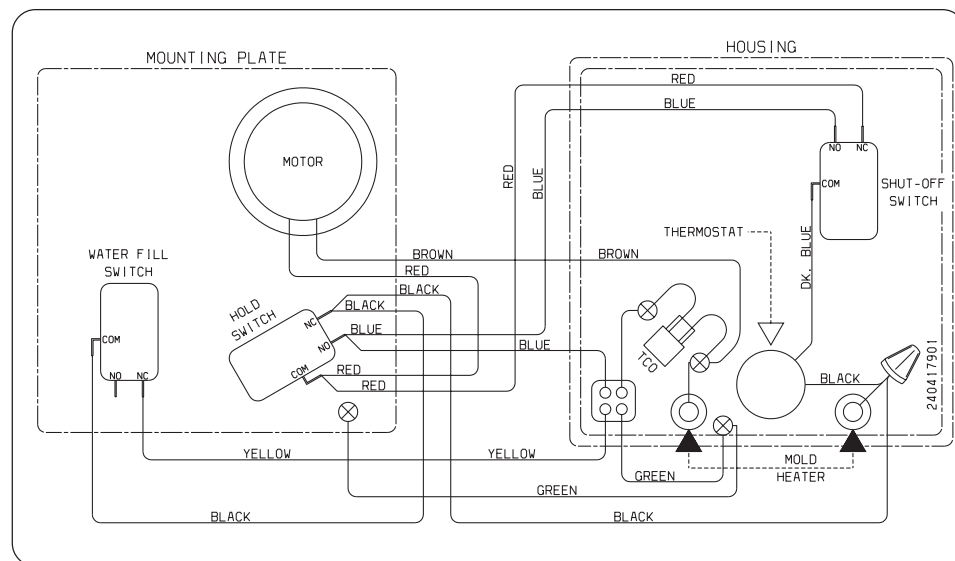

ICE MAKER INFORMATION

Test Cycling

Remove cover by inserting screwdriver in notch at bottom and prying cover from housing. Use screwdriver to rotate motor gear counterclockwise until holding switch circuit is completed. All components of ice maker should function to complete the cycle.

Water Fill Volume

The water fill adjustment screw will change the fill time. One full turn is equal to 20cc (.68 oz.). The correct fill is 102 to 130cc (3.4 to 4.3 oz.). When a water valve is replaced, the fill volume must be checked.

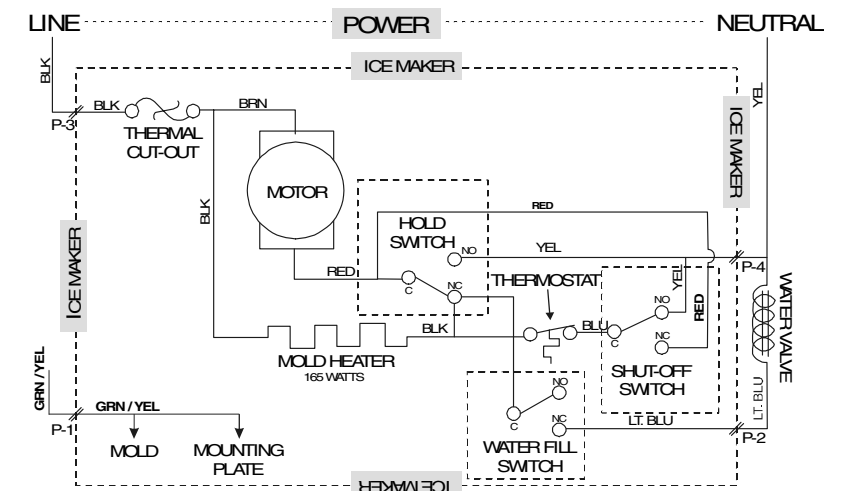
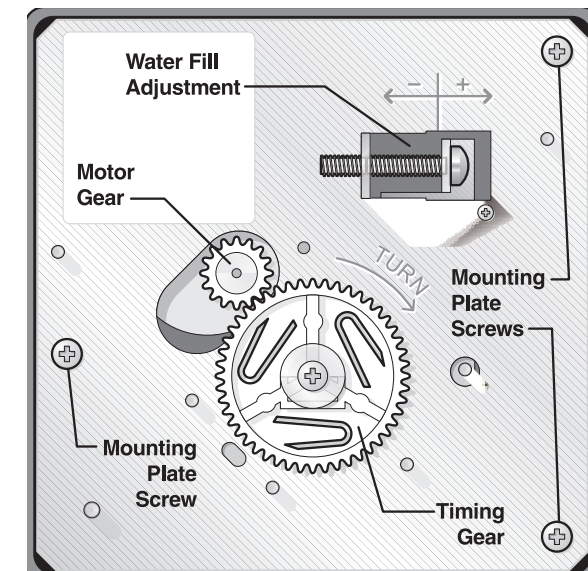

PERFORMANCE DATA NO LOAD AND NO DOOR OPENINGS AT MID-POINT CONTROL SETTING				
Type A With Run/Start Capacitor	65°F (18°C) Ambient	90°F (32°C) Ambient		
Operating Time	32 to 40%	55 to 65%		
Freezer Temperature	0° to 4°F -18° to -16°C	-1° to 3°F -18° to -16°C		
Refrigerator Temperature	34° to 39°F 1° to 4°C	34° to 39°F 1° to 4°C		
Low Side Pressure (cut-in)	5 to 12 psig 34 to 83 kPa	5 to 12 psig 34 to 83 kPa		
Low Side Pressure (cut-out)	-2 to 2 psig -14 to 14 kPa	-2 to 2 psig -14 to 14 kPa		
High Side Pressure (Last 1/3 of cycle)	90 to 115 psig 621 to 793 kPa	130 to 155 psig 896 to 1069 kPa		
Wattage (Last 1/3 of cycle)	120 to 150	130 to 160		
Amps (Running)	1.2 to 1.5	1.2 to 1.5		
Base Voltage	115 VAC	115 VAC		
DEFROST SPECIFICATIONS				
Cabinet Size	Thermostat		Heater	
	Cut-in	Cut-out	Watts	Ohms
23' & 26'	25°F -4°C	47°F 8°C	450	30
Electronic Timer - (ADC) Defrost 24 minutes every 6 to 72 hours of compressor run time.				
CONDENSER FAN MOTOR				
Watts	RPM	Amps		
7	1100 CW Opposite Shaft	.1 Running		
ICE MAKER SPECIFICATIONS				
Electrical	115 Volts	60 Hertz		
Thermostat	Opens at 48°F (9°C)	Closes at 15°F (-9°C)		
Heater Wattage	165			

ICE MAKER CONNECTOR PLUG CONNECTIONS		
Wire Number	Wire Color	Connects to:
1	Green/Yellow	Ground
2	Yellow	Water Valve
3	Black	Line
4	Lt. Blue	Neutral

SERVICE DATA SHEET - 240389607

R134a ICE & WATER - AUTOMATIC DEFROST SIDE BY SIDE MODELS

IMPORTANT SAFETY NOTICE

The information provided herein is designed to assist qualified repair personnel only. Untrained persons should not attempt to make repairs due to the possibility of electrical shock. Disconnect power cord before servicing.

IMPORTANT

If any green grounding wires are moved during servicing, they must be returned to their original position and properly secured.

CAUTION: All electrical parts and wiring must be shielded from torch flame. Do not allow torch to contact insulation; it will char at 200°F and flash ignite (burn) at 500°F. Excessive heat will distort the plastic liner.

NOTE: This product comes equipped with an Electronic Defrost Control. To initiate defrost, depress the fresh food light switch 5 times in 6 seconds (light bulb must be working). To terminate defrost, depress the fresh food light switch 5 times in 6 seconds.

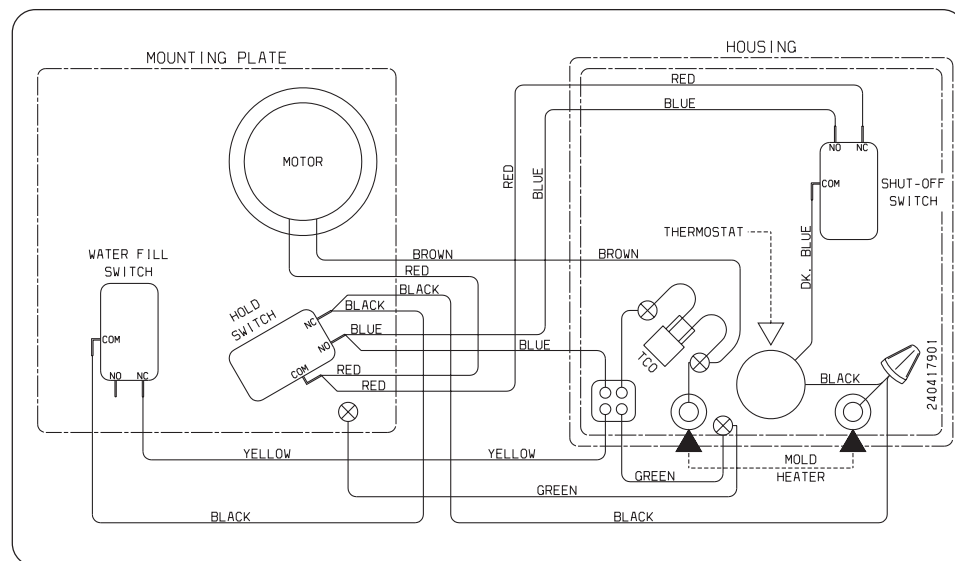

ICE MAKER INFORMATION

Test Cycling

Remove cover by inserting screwdriver in notch at bottom and prying cover from housing. Use screwdriver to rotate motor gear counterclockwise until holding switch circuit is completed. All components of ice maker should function to complete the cycle.

Water Fill Volume

The water fill adjustment screw will change the fill time. One full turn is equal to 20cc (.68 oz.). The correct fill is 102 to 130cc (3.4 to 4.3 oz.). When a water valve is replaced, the fill volume must be checked.

