



ELECTROLUX HOME PRODUCTS NORTH AMERICA

Product Information and Technical Guide

2000 - 2001 Freezers

Including Private Label Brands

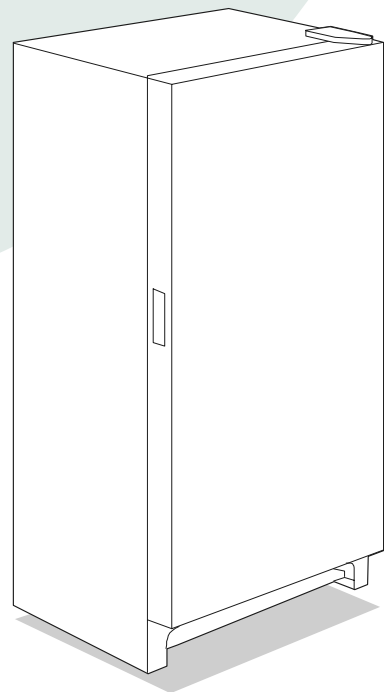
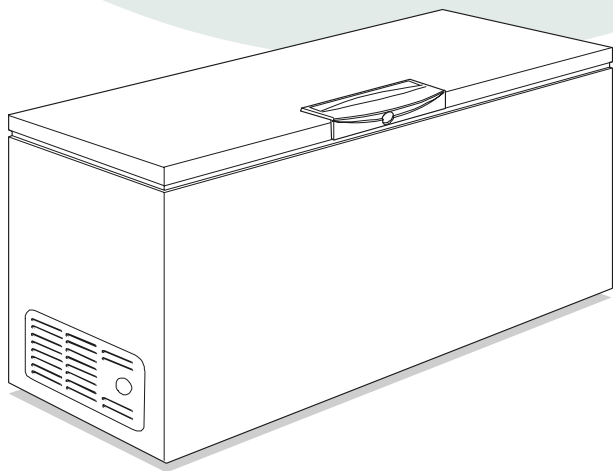

Frigidaire[®]

TAPPAN[®]

W White-Westinghouse[®]

Kelvinator[®] 

Gibson[®]

TABLE OF CONTENTS

SAFE SERVICING PRACTICES	2
---------------------------------------	---

ELECTRICAL SPECIFICATIONS

Broich	3
Edina Tech	3
Frigidaire	4 - 8
Frigidaire - Gallery	8
Gibson	9
Universal / Multiflex	10
Venex Inc.	10
White Westinghouse	10

SYSTEM SPECIFICATIONS

Broich	11
Edina Tech	11
Frigidaire	12 - 16
Frigidaire - Gallery	16
Gibson	17
Universal / Multiflex	18
Venex Inc.	18
White Westinghouse	18

SCHEMATICS INDEX LIST

Broich	19
Edina Tech	19
Frigidaire	20 - 24
Frigidaire - Gallery	24
Gibson	24 - 25
Universal/Multiflex	25 - 26
Venex Inc.	26
White Westinghouse	26

SCHEMATICS

Electrical Circuits	27 - 29
Relay / Overload Schematics	30
System Schematics	31 - 33

TROUBLESHOOTING	34 - 36
------------------------------	---------

NOTES	37
--------------------	----

SAFE SERVICING PRACTICES - ALL APPLIANCES

To avoid the possibility of personal injury and/or property damage, it is important that safe servicing practices be observed. The following are examples, but without limitation, of such practices:

1. **Do not** attempt a product repair if you have any doubts as to your ability to complete it in a safe and satisfactory manner.
2. Before servicing or moving an appliance:
 - remove power cord from electric outlet, trip circuit breaker to OFF, or remove fuse
 - turn off gas supply
 - turn off water supply
3. Never interfere with the proper operation of any safety device.
4. **Use Only Replacement Parts Cataloged For This Appliance. Substitutions May Defeat Compliance With Safety Standards Set For Home Appliances.**
5. **Grounding:** The standard color coding for safety ground wires is **Green**, or **Green with Yellow Stripes**. Ground leads are not to be used as current carrying conductors. **It Is EXTREMELY Important That The Service Technician Reestablish All Safety Grounds Prior To Completion Of Service. Failure To Do So Will Create A Potential Hazard.**
6. Prior to returning the product to service, ensure that:
 - all electric connections are correct and secure
 - all electrical leads are properly dressed and secured away from sharp edges, high-temperature components, and moving parts
 - all uninsulated electrical terminals, connectors, heaters, etc. are adequately spaced away from all metal parts and panels
 - all safety grounds (both internal and external) are correctly and securely connected
 - all panels are properly and securely reassembled

ATTENTION!!!

This service manual is intended for use by persons having electrical and mechanical training and a level of knowledge of these subjects generally considered acceptable in the appliance repair trade. Electrolux Home Products, Inc. cannot be responsible, nor assume any liability, for injury or damage of any kind arising from the use of this manual.

BROICH ELECTRICAL SPECIFICATIONS

MODELS	Control Thermostat Calibration °F		Defrost Timer		Defrost Thermostat Calibration °F		Defrost Heater	
	Warm Position	Cold Position	Defrost Cycle (Min.)	Accum. Run Time (Hrs.)	Close	Open	Watts	Ohms
	Cut-In	Cut-Out						
CF051	22 ± 3	-32.3 ± 3	-	-	-	-	-	-
CF052	22 ± 3	-32.3 ± 3	-	-	-	-	-	-
CF071	22 ± 3	-32.3 ± 3	-	-	-	-	-	-
CF091	22 ± 3	-32.3 ± 3	-	-	-	-	-	-
CF092	22 ± 3	-32.3 ± 3	-	-	-	-	-	-
CF133	11.9 ± 3	-34.3 ± 3	-	-	-	-	-	-
CF153	11.9 ± 3	-34.3 ± 3	-	-	-	-	-	-
CF183	11 ± 3	-34.3 ± 3	-	-	-	-	-	-
F22CW10	29 ± 2	-31.3 ± 3	30.0 ± 3	12	25° ± 7°/-10°	47° ± 5°	550 ± 5°	24
F22CW11	29 ± 2	-31.3 ± 3	30.0 ± 3	12	25° ± 7°/-10°	47° ± 5°	550 ± 5°	24
GTCF050	22 ± 3	-32.3 ± 3	-	-	-	-	-	-
GTCF051	22 ± 3	-32.3 ± 3	-	-	-	-	-	-
R22CW9	29 ± 2	-31.3 ± 3	30.0 ± 3	12	25° ± 7°/-10°	47° ± 5°	550 ± 5°	24
UL1293CA1	20.8 ± 3	-23.4 ± 3	-	-	-	-	-	-
UL1793CA1	20.8 ± 3	-23.4 ± 3	-	-	-	-	-	-
UL1793CA2	20.8 ± 3	-23.4 ± 3	-	-	-	-	-	-
UL2100CA0	20.8 ± 3	-23.4 ± 3	-	-	-	-	-	-
UL2494CA0	15.2 ± 3	-21 ± 3	-	-	-	-	-	-
UL4000CA0	15.5 ± 3	-21 ± 3	-	-	-	-	-	-
UL5000CA0	15.2 ± 3	-21 ± 3	-	-	-	-	-	-
UL5000CA1	20.8 ± 3	-23.4 ± 3	-	-	-	-	-	-
UL5000CA4	20.8 ± 3	-23.4 ± 3	-	-	-	-	-	-

EDINA TECH ELECTRICAL SPECIFICATIONS

FMR8	45.7 ± 3	29.9 ± 3	-	-	-	-	-	-
------	----------	----------	---	---	---	---	---	---

FRIGIDAIRE ELECTRICAL SPECIFICATIONS

MODELS	Control Thermostat Calibration °F		Defrost Timer		Defrost Thermostat Calibration °F		Defrost Heater	
	Warm Position	Cold Position	Defrost Cycle (Min.)	Accum. Run Time (Hrs.)	Close	Open	Watts	Ohms
	Cut-In	Cut-Out						
FFC04M0AW1	27.9 ± 3	-27.3 ± 3	-	-	-	-	-	-
FFC05C2AW0	27.9 ± 3	-27.3 ± 3	-	-	-	-	-	-
FFC05C2AW1	27.9 ± 3	-27.3 ± 3	-	-	-	-	-	-
FFC05K0AW0	27.9 ± 3	-27.3 ± 3	-	-	-	-	-	-
FFC05K0AW1	27.9 ± 3	-27.3 ± 3	-	-	-	-	-	-
FFC05M0AW0	27.9 ± 3	-27.3 ± 3	-	-	-	-	-	-
FFC05M0AW1	27.9 ± 3	-27.3 ± 3	-	-	-	-	-	-
FFC05M2AW0	27.9 ± 3	-27.3 ± 3	-	-	-	-	-	-
FFC05M2AW1	27.9 ± 3	-27.3 ± 3	-	-	-	-	-	-
FFC07C2AW0	27.9 ± 3	-27.3 ± 3	-	-	-	-	-	-
FFC07C3AW0	27.9 ± 3	-27.3 ± 3	-	-	-	-	-	-
FFC07C3AW1	27.9 ± 3	-27.3 ± 3	-	-	-	-	-	-
FFC07C3AW2	27.9 ± 3	-27.3 ± 3	-	-	-	-	-	-
FFC07C4AW0	27.9 ± 3	-27.3 ± 3	-	-	-	-	-	-
FFC07C4AW1	27.9 ± 3	-27.3 ± 3	-	-	-	-	-	-
FFC07C4AW2	27.9 ± 3	-27.3 ± 3	-	-	-	-	-	-
FFC07K0AW0	27.9 ± 3	-27.3 ± 3	-	-	-	-	-	-
FFC07K0AW1	27.9 ± 3	-27.3 ± 3	-	-	-	-	-	-
FFC07K0AW2	27.9 ± 3	-27.3 ± 3	-	-	-	-	-	-
FFC07M2AW0	27.9 ± 3	-27.3 ± 3	-	-	-	-	-	-
FFC07M2AW1	27.9 ± 3	-27.3 ± 3	-	-	-	-	-	-
FFC07M2AW2	27.9 ± 3	-27.3 ± 3	-	-	-	-	-	-
FFC09C2AW0	27.9 ± 3	-27.3 ± 3	-	-	-	-	-	-
FFC09C3AW0	27.9 ± 3	-27.3 ± 3	-	-	-	-	-	-
FFC09C3AW1	27.9 ± 3	-27.3 ± 3	-	-	-	-	-	-
FFC09C4AW0	27.9 ± 3	-27.3 ± 3	-	-	-	-	-	-
FFC09C4AW1	27.9 ± 3	-27.3 ± 3	-	-	-	-	-	-

FRIGIDAIRE ELECTRICAL SPECIFICATIONS

MODELS	Control Thermostat Calibration °F		Defrost Timer		Defrost Thermostat Calibration °F		Defrost Heater	
	Warm Position	Cold Position	Defrost Cycle (Min.)	Accum. Run Time (Hrs.)	Close	Open	Watts	Ohms
	Cut-In	Cut-Out						
FFC09C7AW0	27.9 ± 3	-27.3 ± 3	-	-	-	-	-	-
FFC09C7AW1	27.9 ± 3	-27.3 ± 3	-	-	-	-	-	-
FFC09M2AW0	27.9 ± 3	-27.3 ± 3	-	-	-	-	-	-
FFC09M2AW1	27.9 ± 3	-27.3 ± 3	-	-	-	-	-	-
FFC13C2AW0	14.2 ± 3	-22.3 ± 3	-	-	-	-	-	-
FFC13C3AW0	14.2 ± 3	-22.3 ± 3	-	-	-	-	-	-
FFC13C4AW0	14.2 ± 3	-22.3 ± 3	-	-	-	-	-	-
FFC13C4AW1	14.2 ± 3	-22.3 ± 3	-	-	-	-	-	-
FFC13C7AW0	14.2 ± 3	-22.3 ± 3	-	-	-	-	-	-
FFC13C7AW1	14.2 ± 3	-22.3 ± 3	-	-	-	-	-	-
FFC13K1AW0	14.2 ± 3	-22.3 ± 3	-	-	-	-	-	-
FFC13M2AW0	14.2 ± 3	-22.3 ± 3	-	-	-	-	-	-
FFC13M2AW1	14.2 ± 3	-22.3 ± 3	-	-	-	-	-	-
FFC15C2AW0	14.2 ± 3	-22.3 ± 3	-	-	-	-	-	-
FFC15C3AW0	14.2 ± 3	-22.3 ± 3	-	-	-	-	-	-
FFC15C4AW0	14.2 ± 3	-22.3 ± 3	-	-	-	-	-	-
FFC15C4AW1	14.2 ± 3	-22.3 ± 3	-	-	-	-	-	-
FFC15C7AW0	14.2 ± 3	-22.3 ± 3	-	-	-	-	-	-
FFC15C7AW1	14.2 ± 3	-22.3 ± 3	-	-	-	-	-	-
FFC15M4AW0	14.2 ± 3	-22.3 ± 3	-	-	-	-	-	-
FFC15M4AW1	14.2 ± 3	-22.3 ± 3	-	-	-	-	-	-
FFC20C3AW0	14.2 ± 3	-22.3 ± 3	-	-	-	-	-	-
FFC20C4AW0	14.2 ± 3	-22.3 ± 3	-	-	-	-	-	-
FFC20D5AW0	14.2 ± 3	-22.3 ± 3	-	-	-	-	-	-
FFC25C3AW0	14.2 ± 3	-22.3 ± 3	-	-	-	-	-	-
FFC25C4AW0	14.2 ± 3	-22.3 ± 3	-	-	-	-	-	-

FRIGIDAIRE ELECTRICAL SPECIFICATIONS

MODELS	Control Thermostat Calibration °F		Defrost Timer		Defrost Thermostat Calibration °F		Defrost Heater	
	Warm Position	Cold Position	Defrost Cycle (Min.)	Accum. Run Time (Hrs.)	Close	Open	Watts	Ohms
	Cut-In	Cut-Out						
FFU09K0AW0	20.8 ± 3	-23.4 ± 3	-	-	-	-	-	-
FFU09K0AW1	20.8 ± 3	-23.4 ± 3	-	-	-	-	-	-
FFU09K0AW2	23.1 ± 3	-25.0 ± 3	-	-	-	-	-	-
FFU09M2AW0	20.8 ± 3	-23.4 ± 3	-	-	-	-	-	-
FFU09M2AW1	20.8 ± 3	-23.4 ± 3	-	-	-	-	-	-
FFU09M2AW2	23.1 ± 3	-25.0 ± 3	-	-	-	-	-	-
FFU11F3AW0	17.1 ± 3	-24.8 ± 3	-	-	-	-	-	-
FFU11FK2AW0	17.1 ± 3	-24.8 ± 3	-	-	-	-	-	-
FFU11FK2AW1	17.1 ± 3	-24.8 ± 3	-	-	-	-	-	-
FFU11FK2AW2	17.1 ± 3	-24.8 ± 3	-	-	-	-	-	-
FFU12C2AW0	20.8 ± 3	-23.4 ± 3	-	-	-	-	-	-
FFU12M2AW0	20.8 ± 3	-23.4 ± 3	-	-	-	-	-	-
FFU12M2AW1	20.8 ± 3	-23.4 ± 3	-	-	-	-	-	-
FFU12M2AW2	20.8 ± 3	-23.4 ± 3	-	-	-	-	-	-
FFU14C2AW0	20.8 ± 3	-23.4 ± 3	-	-	-	-	-	-
FFU14C4AW0	20.8 ± 3	-23.4 ± 3	-	-	-	-	-	-
FFU14F3AW0	17.1 ± 3	-24.8 ± 3	-	-	-	-	-	-
FFU14F3AW1	17.1 ± 3	-24.8 ± 3	-	-	-	-	-	-
FFU14F3AW2	17.1 ± 3	-24.8 ± 3	-	-	-	-	-	-
FFU14FC3AW0	17.1 ± 3	-24.8 ± 3	-	-	-	-	-	-
FFU14FC4AW0	17.1 ± 3	-24.8 ± 3	-	-	-	-	-	-
FFU14M2AW0	20.8 ± 3	-23.4 ± 3	-	-	-	-	-	-
FFU14M2AW1	20.8 ± 3	-23.4 ± 3	-	-	-	-	-	-
FFU17C2AW0	15.5 ± 3	-21.0 ± 3	-	-	-	-	-	-
FFU17C3AW0	15.5 ± 3	-21.0 ± 3	-	-	-	-	-	-
FFU17C3AW1	15.5 ± 3	-21.0 ± 3	-	-	-	-	-	-

FRIGIDAIRE ELECTRICAL SPECIFICATIONS

MODELS	Control Thermostat Calibration °F		Defrost Timer		Defrost Thermostat Calibration °F		Defrost Heater	
	Warm Position	Cold Position	Defrost Cycle (Min.)	Accum. Run Time (Hrs.)	Close	Open	Watts	Ohms
	Cut-In	Cut-Out						
FFU17C4AW0	15.5 ± 3	-21.0 ± 3	-	-	-	-	-	-
FFU17F3AW0	24 ± 3	-24 ± 3	30 ± 3	12	25° ± 7°	42° ± 5°	550 ± 5°	24
FFU17F9GW5	24 ± 3	-24 ± 3	30 ± 3	12	25° ± 7°	42° ± 5°	550 ± 5°	24
FFU17FC3AW0	24 ± 3	-24 ± 3	30 ± 3	12	25° ± 7°	42° ± 5°	550 ± 5°	24
FFU17FC4AW0	24 ± 3	-24 ± 3	30 ± 3	12	25° ± 7°	42° ± 5°	550 ± 5°	24
FFU17M2AW0	24 ± 3	-24 ± 3	-	-	-	-	-	-
FFU20F3AW0	24 ± 3	-24 ± 3	30 ± 3	12	25° ± 7°	42° ± 5°	550 ± 5°	24
FFU20F3AW1	24 ± 3	-24 ± 3	30 ± 3	12	25° ± 7°	42° ± 5°	550 ± 5°	24
FFU20F3AW2	24 ± 3	-24 ± 3	30 ± 3	12	25° ± 7°	42° ± 5°	550 ± 5°	24
FFU20FC3AW0	24 ± 3	-24 ± 3	30 ± 3	12	25° ± 7°	42° ± 5°	550 ± 5°	24
FFU20FC4AW0	24 ± 3	-24 ± 3	30 ± 3	12	25° ± 7°	42° ± 5°	550 ± 5°	24
FFU20FC6AW0	24 ± 3	-24 ± 3	30 ± 3	12	25° ± 7°	42° ± 5°	550 ± 5°	24
FFU20FC6AW1	24 ± 3	-24 ± 3	30 ± 3	12	25° ± 7°	42° ± 5°	550 ± 5°	24
FFU20FC6AW2	24 ± 3	-24 ± 3	30 ± 3	12	25° ± 7°	42° ± 5°	550 ± 5°	24
FFU21C2AW0	15.5 ± 3	-21.0 ± 3	-	-	-	-	-	-
FFU21C3AW0	15.5 ± 3	-21.0 ± 3	-	-	-	-	-	-
FFU21C5AW0	15.2 ± 3	-21.0 ± 3	-	-	-	-	-	-
FFU21C5AW1	15.2 ± 3	-21.0 ± 3	-	-	-	-	-	-
FFU21M2AW0	15.5 ± 3	-21.0 ± 3	-	-	-	-	-	-
FRU17B2JW0	25.7 ± 3	21.7 ± 3	30 ± 3	12	25° ± 7°	42° ± 5°	550 ± 5°	24
FRU17B2JW1	25.7 ± 3	21.7 ± 3	30 ± 3	12	25° ± 7°	42° ± 5°	550 ± 5°	24
FRU17B2JW3	25.7 ± 3	21.7 ± 3	30 ± 3	12	25° ± 7°	42° ± 5°	550 ± 5°	24
FRU17B2JW4	25.7 ± 3	21.7 ± 3	30 ± 3	12	25° ± 7°	42° ± 5°	550 ± 5°	24
FRU17B2JW6	25.7 ± 3	21.7 ± 3	30 ± 3	12	25° ± 7°	42° ± 5°	550 ± 5°	24
FRU17G4JW0	25.7 ± 3	21.7 ± 3	30 ± 3	12	25° ± 7°	42° ± 5°	550 ± 5°	24
FRU17G4JW1	25.7 ± 3	21.7 ± 3	30 ± 3	12	25° ± 7°	42° ± 5°	550 ± 5°	24

FRIGIDAIRE ELECTRICAL SPECIFICATIONS

MODELS	Control Thermostat Calibration °F		Defrost Timer		Defrost Thermostat Calibration °F		Defrost Heater	
	Warm Position	Cold Position	Defrost Cycle (Min.)	Accum. Run Time (Hrs.)	Close	Open	Watts	Ohms
	Cut-In	Cut-Out						
FRU17G4JW2	25.7 ± 3	21.7 ± 3	30 ± 3	12	25° ± 7°	42° ± 5°	550 ± 5°	24
FRU17G4JW3	25.7 ± 3	21.7 ± 3	30 ± 3	12	25° ± 7°	42° ± 5°	550 ± 5°	24
FRU17G4JW4	25.7 ± 3	21.7 ± 3	30 ± 3	12	25° ± 7°	42° ± 5°	550 ± 5°	24
FRU17G4JW5	25.7 ± 3	21.7 ± 3	30 ± 3	12	25° ± 7°	42° ± 5°	550 ± 5°	24
FRU17G4JW6	25.7 ± 3	21.7 ± 3	30 ± 3	12	25° ± 7°	42° ± 5°	550 ± 5°	24
MFC07M1BW5	33 ± 3	-24.5 ± 3	-	-	-	-	-	-
MFC07M3FW4	27.9 ± 3	-27.3 ± 3	-	-	-	-	-	-
MFC09M3FW2	33 ± 3	-24.5 ± 3	-	-	-	-	-	-
MFC09M3FW3	27.9 ± 3	-27.3 ± 3	-	-	-	-	-	-
MFC20M4FW4	14.2 ± 3	-22.3 ± 3	-	-	-	-	-	-
MFU14M2GW4	20.5 ± 3	-27.7 ± 3	-	-	-	-	-	-
MFU14M2GW5	*	*	*	*	*	*	*	*

FRIGIDAIRE (GALLERY) ELECTRICAL SPECIFICATIONS

FFC07G4AW0	27.9 ± 3	-27.3 ± 3	-	-	-	-	-	-
FFC07G4AW1	27.9 ± 3	-27.3 ± 3	-	-	-	-	-	-
FFC09G7AW0	27.9 ± 3	-27.3 ± 3	-	-	-	-	-	-
FFC13G7AW0	14.2 ± 3	-22.3 ± 3	-	-	-	-	-	-
FFC15G7AW0	14.2 ± 3	-22.3 ± 3	-	-	-	-	-	-
FFC20G4AW0	14.2 ± 3	-22.3 ± 3	-	-	-	-	-	-
FFC25G4AW0	14.2 ± 3	-22.3 ± 3	-	-	-	-	-	-
FFU14FG4AW0	17.1 ± 3	-24.8 ± 3	30 ± 3	12	25° ± 7°	42° ± 5°	400 ± 5°	33

* Information not available

GIBSON ELECTRICAL SPECIFICATIONS

MODELS	Control Thermostat Calibration °F		Defrost Timer		Defrost Thermostat Calibration °F		Defrost Heater	
	Warm Position	Cold Position	Defrost Cycle (Min.)	Accum. Run Time (Hrs.)	Close	Open	Watts	Ohms
	Cut-In	Cut-Out						
GFC05M0AW0	27.9 ± 3	-27.3 ± 3	-	-	-	-	-	-
GFC05M0AW1	27.9 ± 3	-27.3 ± 3	-	-	-	-	-	-
GFC05M3AW0	27.9 ± 3	-27.3 ± 3	-	-	-	-	-	-
GFC05M3AW1	27.9 ± 3	-27.3 ± 3	-	-	-	-	-	-
GFC07M3AW0	27.9 ± 3	-27.3 ± 3	-	-	-	-	-	-
GFC07M3AW1	27.9 ± 3	-27.3 ± 3	-	-	-	-	-	-
GFC07M3AW2	27.9 ± 3	-27.3 ± 3	-	-	-	-	-	-
GFC09M3AW0	27.9 ± 3	-27.3 ± 3	-	-	-	-	-	-
GFC09M3AW1	27.9 ± 3	-27.3 ± 3	-	-	-	-	-	-
GFC15M3AW0	14.2 ± 3	-22.3 ± 3	-	-	-	-	-	-
GFC15M4AW6	14.2 ± 3	-22.3 ± 3	-	-	-	-	-	-
GFC25M4AW0	14.2 ± 3	-22.3 ± 3	-	-	-	-	-	-
GFU14F3AW0	17.1 ± 3	-24.8 ± 3	30 ± 3	12	25° ± 7°	42° ± 5°	400 ± 5%	33
GFU14F3AW1	17.1 ± 3	-24.8 ± 3	30 ± 3	12	25° ± 7°	42° ± 5°	400 ± 5%	33
GFU17F5AW0	24 ± 3	-24 ± 3	30 ± 3	12	25° ± 7°	42° ± 5°	550 ± 5%	24
GFU17F5AW1	24 ± 3	-24 ± 3	30 ± 3	12	25° ± 7°	42° ± 5°	550 ± 5%	24
GFU17M3AW0	15.5 ± 3	-21 ± 3	-	-	-	-	-	-
GFU17M3AW1	20.8 ± 3	-23.4 ± 3	-	-	-	-	-	-
GFU20F5AW0	24 ± 3	-24 ± 3	30 ± 3	12	25° ± 7°	42° ± 5°	550 ± 5%	24
GFU20F5AW1	24 ± 3	-24 ± 3	30 ± 3	12	25° ± 7°	42° ± 5°	550 ± 5%	24
GFU21M3AW0	15.5 ± 3	-21 ± 3	-	-	-	-	-	-
GFU21M6AW0	15.2 ± 3	-21 ± 3	-	-	-	-	-	-
GFU21M6AW1	15.2 ± 3	-21 ± 3	-	-	-	-	-	-
GFU21M6AW2	15.2 ± 3	-21 ± 3	-	-	-	-	-	-
GRU17B2JW0	25.7 ± 3	21.7 ± 3	30 ± 3	12	25° ± 7°	42° ± 5°	550 ± 5%	24
GRU17B2JW1	25.7 ± 3	21.7 ± 3	30 ± 3	12	25° ± 7°	42° ± 5°	550 ± 5%	24
GRU17B2JW2	25.7 ± 3	21.7 ± 3	30 ± 3	12	25° ± 7°	42° ± 5°	550 ± 5%	24
GRU17B2JW4	25.7 ± 3	21.7 ± 3	30 ± 3	12	25° ± 7°	42° ± 5°	550 ± 5%	24
GRU17B2JW5	25.7 ± 3	21.7 ± 3	30 ± 3	12	25° ± 7°	42° ± 5°	550 ± 5%	24

UNIVERSAL / MULTIFLEX ELECTRICAL SPECIFICATIONS

MODELS	Control Thermostat Calibration °F		Defrost Timer		Defrost Thermostat Calibration °F		Defrost Heater	
	Warm Position	Cold Position	Defrost Cycle (Min.)	Accum. Run Time (Hrs.)	Close	Open	Watts	Ohms
	Cut-In	Cut-Out						
CFC05M0AW0	27.9 ± 3	-27.3 ± 3	-	-	-	-	-	-
CFC05M0AW1	27.9 ± 3	-27.3 ± 3	-	-	-	-	-	-
CFC07M1AW0	27.9 ± 3	-27.3 ± 3	-	-	-	-	-	-
CFC07M1AW2	27.9 ± 3	-27.3 ± 3	-	-	-	-	-	-
CFC07M4AW0	27.9 ± 3	-27.3 ± 3	-	-	-	-	-	-
CFC07M4AW2	27.9 ± 3	-27.3 ± 3	-	-	-	-	-	-
CFC09M4AW0	27.9 ± 3	-27.3 ± 3	-	-	-	-	-	-
CFC09M4AW1	27.9 ± 3	-27.3 ± 3	-	-	-	-	-	-
CFC09M5AW0	27.9 ± 3	-27.3 ± 3	-	-	-	-	-	-
CFC13M5AW0	14.2 ± 3	-22.3 ± 3	-	-	-	-	-	-
CFC13M5AW1	14.2 ± 3	-22.3 ± 3	-	-	-	-	-	-
CFU09M2AW0	20.8 ± 3	-23.4 ± 3	-	-	-	-	-	-
CFU09M2AW1	23.1 ± 3	-25.0 ± 3	-	-	-	-	-	-
CFU12M2AW0	20.8 ± 3	-23.4 ± 3	-	-	-	-	-	-
CFU12M2AW1	20.8 ± 3	-23.4 ± 3	-	-	-	-	-	-
CFU14M2AW0	20.8 ± 3	-23.4 ± 3	-	-	-	-	-	-
CFU14M2AW1	20.8 ± 3	-23.4 ± 3	-	-	-	-	-	-
CFU17F3AW1	24 ± 3	-24 ± 3	-	-	-	-	-	-

VENEX ELECTRICAL SPECIFICATIONS

ER1411	17.6 ± 3	-21.2 ± 3	30 ± 3	12	25° ± 7°	42° ± 5°	400 ± 5%	33
ER1412	17.6 ± 3	-21.2 ± 3	30 ± 3	12	25° ± 7°	42° ± 5°	400 ± 5%	33
ER148	17.6 ± 3	-21. ± 3	29.9 ± 3.6	12	25° ± 7°	42° ± 5°	400 ± 5%	33
VC200	24 ± 2	-24 ± 2	30 ± 3	12	25° ± 7°	42° ± 5°	550 ± 5%	24
VV2010	24 ± 2	-24 ± 2	30 ± 3	12	25° ± 7°	42° ± 5°	550 ± 5%	24
VV2011	24 ± 3	-24 ± 3	30 ± 3	12	25° ± 7°	42° ± 5°	550 ± 5%	24

WHITE WESTINGHOUSE ELECTRICAL SPECIFICATIONS

WFC20M3AW0	14.2 ± 3	-22.3 ± 3	-	-	-	-	-	-
WFC25M3AW0	14.2 ± 3	-22.3 ± 3	-	-	-	-	-	-

BROICH SYSTEM SPECIFICATIONS

MODELS	Compressor Type	Refrigerant (R134a) Oz.	Suction Pressure - PSIG				High Side PSIG (Last 1/3 of cycle)		Wattage Range (Last 1/3 of cycle)	
			Ambient 70°F		Ambient 90°F		70°F	90°F	70°F	90°F
			Cut-In	Cut-Out	Cut-In	Cut-Out				
CF051	EMI60HSC	7	*	*	*	*	*	*	*	
CF052	EMI60HSC	5.5	*	*	*	*	*	*	*	
CF071	EMI60HSC	7	*	*	*	*	*	*	*	
CF091	EMI60HSC	7	*	*	*	*	*	*	*	
CF092	EMI60HSC	8	*	*	*	*	*	*	*	
CF133	RG213-1-3734	9	*	*	*	*	*	*	*	
CF153	RG213-1-3734	9.5	*	*	*	*	*	*	*	
CF183	RG213-1-3734	10.5	*	*	*	*	*	*	*	
F22CW10	RG213-1-3734	9.5	*	*	*	*	*	*	*	
F22CW11	RG213-1-3734	9.5	*	*	*	*	*	*	*	
GTCF050	EMI60HSC	5.5	*	*	*	*	*	*	*	
GTCF051	EMI60HSC	5.5	*	*	*	*	*	*	*	
R22CW9	RF107-1-3699	9.5	*	*	*	*	*	*	*	
UL1293CA1	RF107-1-3699	7	*	*	*	*	*	*	*	
UL1793CA1	TPE1370YXA	7.5	14	0	14	0	110-125	155-170	105-120	110-125
UL1793CA2	TPE1370YXA	7.5	14	0	14	0	110-125	155-170	105-120	110-125
UL2100CA1	GRH107-1-3764	9	14	0	14	0	110-125	155-170	105-120	110-125
UL2494CA0	GRH107-1-3764	9	14	0	14	0	110-125	155-170	105-120	110-125
UL4000CA0	GRH207-1-3765	9.75	14	0	14	0	110-125	155-170	105-120	110-125
UL5000CA0	GRH207-1-3765	9.75	14	0	14	0	110-125	155-170	105-120	110-125
UL5000CA1	GRH207-1-3765	9.75	14	0	14	0	110-125	155-170	105-120	110-125
UL5000CA4	GRH207-1-3765	9.75	14	0	14	0	110-125	155-170	105-120	110-125

EDINA TECH SYSTEM SPECIFICATIONS

FMR8	EM45HNR	*	*	*	*	*	*	*	*
------	---------	---	---	---	---	---	---	---	---

* Information not available.

FRIGIDAIRE SYSTEM SPECIFICATIONS

MODELS	Compressor Type	Refrigerant (R134a) Oz.	Suction Pressure - PSIG				High Side PSIG (Last 1/3 of cycle)		Wattage Range (Last 1/3 of cycle)	
			Ambient 70°F		Ambient 90°F		70°F	90°F	70°F	90°F
			Cut-In	Cut-Out	Cut-In	Cut-Out				
FFC04M0AW1	NDA30LACM	4.8	12	0	12	0	110-130	145-165	65-85	70-85
FFC05C2AW0	NDA30LACM	4.8	12	0	12	0	110-130	145-165	65-85	70-85
FFC05C2AW1	NDA30LACM	5.5	12	0	12	0	110-130	145-165	65-85	70-85
FFC05K0AW0	NDA30LACM	5.5	12	0	12	0	110-130	145-165	65-85	70-85
FFC05K0AW1	NDA30LACM	5.5	12	0	12	0	110-130	145-165	65-85	70-85
FFC05M0AW0	NDA30LACM	5.5	12	0	12	0	110-130	145-165	65-85	70-85
FFC05M0AW1	NDA30LACM	5.5	12	0	12	0	110-130	145-165	65-85	70-85
FFC05M2AW0	NDA30LACM	5.5	12	0	12	0	110-130	145-165	65-85	70-85
FFC05M2AW1	NDA30LACM	5.5	12	0	12	0	110-130	145-165	65-85	70-85
FFC07C2AW0	EMU45HSC	7	12	0	12	0	110-130	145-165	65-85	70-85
FFC07C3AW0	EMU45HSC	7	12	0	12	0	110-130	145-165	65-85	70-85
FFC07C3AW1	KX40LACM	6.5	12	0	12	0	110-130	145-165	65-85	70-85
FFC07C3AW2	KX40LACM	6.5	12	0	12	0	110-130	145-165	65-85	70-85
FFC07C4AW0	EMU45HSC	7	12	0	12	0	110-130	145-165	65-85	70-85
FFC07C4AW1	EMU45HSC	7	12	0	12	0	110-130	145-165	65-85	70-85
FFC07C4AW2	KX40LACM	6.5	12	0	12	0	110-130	145-165	65-85	70-85
FFC07K0AW0	EMU45HSC	7	12	0	12	0	110-130	145-165	65-85	70-85
FFC07K0AW1	KX40LACM	6.5	12	0	12	0	110-130	145-165	65-85	70-85
FFC07K0AW2	KX40LACM	6.5	12	0	12	0	110-130	145-165	65-85	70-85
FFC07M2AW0	EMU45HSC	7	12	0	12	0	110-130	145-165	65-85	70-85
FFC07M2AW1	KX40LACM	6.5	12	0	12	0	110-130	145-165	65-85	70-85
FFC07M2AW2	KX40LACM	6.5	12	0	12	0	110-130	145-165	65-85	70-85
FFC09C2AW0	EMU45HSC	8	12	0	12	0	110-130	145-165	65-85	70-85
FFC09C3AW0	EMU45HSC	8	12	0	12	0	110-130	145-165	65-85	70-85
FFC09C3AW1	EMU45HSC	8	12	0	12	0	110-130	145-165	65-85	70-85
FFC09C4AW0	EMU45HSC	8	12	0	12	0	110-130	145-165	65-85	70-85
FFC09C4AW1	EMU45HSC	8	12	0	12	0	110-130	145-165	65-85	70-85

FRIGIDAIRE SYSTEM SPECIFICATIONS

MODELS	Compressor Type	Refrigerant (R134a) Oz.	Suction Pressure - PSIG				High Side PSIG (Last 1/3 of cycle)		Wattage Range (Last 1/3 of cycle)	
			Ambient 70°F		Ambient 90°F		70°F	90°F	70°F	90°F
			Cut-In	Cut-Out	Cut-In	Cut-Out				
FFC09C7AW0	EMU45HSC	8	12	0	12	0	110-130	145-165	65-85	70-85
FFC09C7AW1	EMU45HSC	8	12	0	12	0	110-130	145-165	65-85	70-85
FFC09M2AW0	EMU45HSC	8	12	0	12	0	110-130	145-165	65-85	70-85
FFC09M2AW1	EMU45HSC	8	12	0	12	0	110-130	145-165	65-85	70-85
FFC13C2AW0	EMU60HSC	9	15	0	15	0	95-110	140-155	85-100	95-110
FFC13C3AW0	EMU60HSC	9	15	0	15	0	95-110	140-155	85-100	95-110
FFC13C4AW0	EMU60HSC	9	15	0	15	0	95-110	140-155	85-100	95-110
FFC13C4AW1	EMU60HSC	9	15	0	15	0	95-110	140-155	85-100	95-110
FFC13C7AW0	EMU60HSC	9	15	0	15	0	95-110	140-155	85-100	95-110
FFC13C7AW1	EMU60HSC	9	15	0	15	0	95-110	140-155	85-100	95-110
FFC13K1AW0	EMU60HSC	9	15	0	15	0	95-110	140-155	85-100	95-110
FFC13M2AW0	EMU60HSC	9	15	0	15	0	95-110	140-155	85-100	95-110
FFC13M2AW1	EMU60HSC	9	15	0	15	0	95-110	140-155	85-100	95-110
FFC15C2AW0	EMU60HSC	10	15	0	15	0	95-110	140-155	85-100	95-110
FFC15C3AW0	EMU60HSC	10	15	0	15	0	95-110	140-155	85-100	95-110
FFC15C4AW0	EMU60HSC	10	15	0	15	0	95-110	140-155	85-100	95-110
FFC15C4AW1	EMU60HSC	10	15	0	15	0	95-110	140-155	85-100	95-110
FFC15C7AW0	EMU60HSC	10	15	0	15	0	95-110	140-155	85-100	95-110
FFC15C7AW1	EMU60HSC	10	15	0	15	0	95-110	140-155	85-100	95-110
FFC15M4AW0	EMU60HSC	10	15	0	15	0	95-110	140-155	85-100	95-110
FFC15M4AW1	EMU60HSC	10	15	0	15	0	95-110	140-155	85-100	95-110
FFC20C3AW0	EGU80HLCW	11	15	0	15	0	105-125	155-165	100-140	110-145
FFC20C4AW0	EGU80HLCW	11	15	0	15	0	105-125	155-165	100-140	110-145
FFC20D5AW0	EGU80HLCW	11	15	0	15	0	105-125	155-165	100-140	110-145
FFC25C3AW0	EGU80HLCW	12.5	15	0	15	0	105-125	155-165	100-140	110-145
FFC25C4AW0	EGU80HLCW	12.5	15	0	15	0	105-125	155-165	100-140	110-145

FRIGIDAIRE SYSTEM SPECIFICATIONS

MODELS	Compressor Type	Refrigerant (R134a) Oz.	Suction Pressure - PSIG				High Side PSIG (Last 1/3 of cycle)		Wattage Range (Last 1/3 of cycle)	
			Ambient 70°F		Ambient 90°F		70°F	90°F	70°F	90°F
			Cut-In	Cut-Out	Cut-In	Cut-Out				
FFU09K0AW0	NSB30LBCM	7	15	0	15	0	105-115	140-160	70-110	70-110
FFU09K0AW1	NSB30LBCM	7	15	0	15	0	105-115	140-160	70-110	70-110
FFU09K0AW2	NSB30LBCM	7	15	0	15	0	105-115	140-160	70-110	70-110
FFU09M2AW0	NSB30LBCM	7	15	0	15	0	105-115	140-160	70-110	70-110
FFU09M2AW1	NSB30LBCM	7	15	0	15	0	105-115	140-160	70-110	70-110
FFU09M2AW2	NSB30LBCM	7	15	0	15	0	105-115	140-160	70-110	70-110
FFU11F3AW0	EM160HSC	5	14	0	14	0	110-125	150-165	110-125	115-130
FFU11FK2AW0	EM160HSC	5	14	0	14	0	110-125	150-165	110-125	115-130
FFU11FK2AW1	EM160HSC	5	14	0	14	0	110-125	150-165	110-125	115-130
FFU11FK2AW2	EM160HSC	5	14	0	14	0	110-125	150-165	110-125	115-130
FFU12C2AW0	ND40LBCM	7	15	0	15	0	105-115	140-160	70-110	70-110
FFU12M2AW0	ND40LBCM	7	15	0	15	0	105-115	140-160	70-110	70-110
FFU12M2AW1	ND40LBCM	7	15	0	15	0	105-115	140-160	70-110	70-110
FFU12M2AW2	ND40LBCM	7	15	0	15	0	105-115	140-160	70-110	70-110
FFU14C2AW0	EMU60HSC	8	15	0	15	0	105-115	140-160	70-110	70-110
FFU14C3AW0	ND40LBCM	7	15	0	15	0	105-115	140-160	70-110	70-110
FFU14F3AW0	EMU60HSC	5.5	14	0	14	0	110-125	150-165	110-125	115-130
FFU14F3AW1	EMU60HSC	5.5	14	0	14	0	110-125	150-165	110-125	115-130
FFU14F3AW2	EMU60HSC	5.5	14	0	14	0	110-125	150-165	110-125	115-130
FFU14FC3AW0	EMU60HSC	5.5	14	0	14	0	110-125	150-165	110-125	115-130
FFU14FC4AW0	EMU60HSC	5.5	14	0	14	0	110-125	150-165	110-125	115-130
FFU14M2AW0	EMU60HSC	8	15	0	15	0	105-115	140-160	70-110	70-110
FFU14M2AW1	EMU60HSC	8	15	0	15	0	105-115	140-160	70-110	70-110
FFU17C2AW0	EGU70HLC	7.5	14	0	14	0	110-125	155-170	105-120	110-125
FFU17C3AW0	EGU70HLC	7.5	14	0	14	0	110-125	155-170	105-120	110-125
FFU17C3AW1	EGU70HLC	7.5	14	0	14	0	110-125	155-170	105-120	110-125

FRIGIDAIRE SYSTEM SPECIFICATIONS

MODELS	Compressor Type	Refrigerant (R134a) Oz.	Suction Pressure - PSIG				High Side PSIG (Last 1/3 of cycle)		Wattage Range (Last 1/3 of cycle)	
			Ambient 70°F		Ambient 90°F		70°F	90°F	70°F	90°F
			Cut-In	Cut-Out	Cut-In	Cut-Out				
FFU17C4AW0	EGU70HLC	7.5	14	0	14	0	110-125	155-170	105-120	110-125
FFU17F3AW0	GRH207-1-3765	7.3	14	0	14	0	100-115	140-155	115-140	120-145
FFU17FC3AW0	GRH207-1-3765	7.3	14	0	14	0	100-115	140-155	115-140	120-145
FFU17FC4AW0	GRH207-1-3765	7.3	14	0	14	0	100-115	140-155	115-140	120-145
FFU17M2AW0	EGU70HLC	7.5	14	0	14	0	110-125	155-170	105-120	110-125
FFU20F3AW0	GRH208-1-3767	7.5	15	0	15	0	105-115	140-160	70-110	70-110
FFU20F3AW1	GRH208-1-3767	7.5	14	0	14	0	100-115	140-155	115-140	120-145
FFU20F3AW2	GRH208-1-3767	7.5	14	0	14	0	100-115	140-155	115-140	120-145
FFU20FC3AW0	GRH208-1-3767	7.5	14	0	14	0	100-115	140-155	115-140	120-145
FFU20FC4AW0	GRH208-1-3767	7.5	14	0	14	0	100-115	140-155	115-140	120-145
FFU20FC6AW0	GRH208-1-3767	7.5	14	0	14	0	100-115	140-155	115-140	120-145
FFU20FC6AW1	GRH208-1-3767	7.5	14	0	14	0	100-115	140-155	115-140	120-145
FFU20FC6AW2	GRH208-1-3767	7.5	14	0	14	0	100-115	140-155	115-140	120-145
FFU21C2AW0	GRH107-1-3764	9	14	0	14	0	100-125	155-170	105-120	110-125
FFU21C3AW0	GRH107-1-3764	9	14	0	14	0	100-125	155-170	105-120	110-125
FFU21C5AW0	GRH107-1-3764	9	14	0	14	0	100-125	155-170	105-120	110-125
FFU21C5AW1	GRH107-1-3764	9	14	0	14	0	100-125	155-170	105-120	110-125
FFU21M2AW0	GRH107-1-3764	9	14	0	14	0	100-125	155-170	105-120	110-125
FRU17B2JW0	EM30HNR	6	*	*	*	*	*	*	*	*
FRU17B2JW1	EM30HNR	6	*	*	*	*	*	*	*	*
FRU17B2JW3	EM30HNR	6	*	*	*	*	*	*	*	*
FRU17B2JW4	EM30HNR	6	*	*	*	*	*	*	*	*
FRU17B2JW5	NDA30LACM	6	*	*	*	*	*	*	*	*
FRU17G4JW0	EM30HNR	6	*	*	*	*	*	*	*	*
FRU17G4JW1	EM30HNR	6	*	*	*	*	*	*	*	*
FRU17G4JW2	EM30HNR	6	*	*	*	*	*	*	*	*

* Information not available

FRIGIDAIRE SYSTEM SPECIFICATIONS

MODELS	Compressor Type	Refrigerant (R134a) Oz.	Suction Pressure - PSIG				High Side PSIG (Last 1/3 of cycle)		Wattage Range (Last 1/3 of cycle)	
			Ambient 70°F		Ambient 90°F		70°F	90°F	70°F	90°F
			Cut-In	Cut-Out	Cut-In	Cut-Out				
FRU17G4JW3	EM30HNR	6	*	*	*	*	*	*	*	*
FRU17G4JW4	EM30HNR	6	*	*	*	*	*	*	*	*
FRU17G4JW5	EM30HNR	6	*	*	*	*	*	*	*	*
FRU17G4JW6	EM30HNR	6	*	*	*	*	*	*	*	*
MFC07M1BW5	EM45HER	7	12	0	12	0	120-130	155-165	85-95	85-95
MFC07M3FW4	EMU45HSC	7	12	0	12	0	120-130	155-165	85-95	85-95
MFC09M3FW2	EM45HER	8	12	0	12	0	120-130	155-165	85-95	85-95
MFC09M3FW3	EMU45HSC	8	12	0	12	0	120-130	155-165	85-95	85-95
MFC20M4FW4	FGS70HA	11.5	15	0	15	0	105-120	140-155	115-130	115-135
MFU14M2GW4	EM55HNR	8	15	0	15	0	100-115	140-150	75-110	75-110
MFU14M2GW5	EM60HSC	8	15	0	15	0	105-115	140-160	70-110	70-110

FRIGIDAIRE (GALLERY) SYSTEM SPECIFICATIONS

FFC07G4AW0	EMU45HSC	7	12	0	12	0	110-130	145-165	65-85	70-85
FFC07G4AW1	EMU45HSC	7	12	0	12	0	110-130	145-165	65-85	70-85
FFC09G7AW0	EMU45HSC	8	12	0	12	0	110-130	145-165	65-85	70-85
FFC13G7AW0	EMU60HSC	9	15	0	15	0	95-110	140-155	85-100	95-110
FFC15G7AW0	EMU60HSC	10	15	0	15	0	95-110	140-155	85-100	95-110
FFC20G4AW0	EGU80HLCW	11	15	0	15	0	105-125	155-165	100-140	110-145
FFC25G4AW0	EGU90HLCW	12.5	15	0	15	0	105-125	155-165	100-140	110-145
FFU14G4AW0	EMU60HSC	5.5	14	0	14	0	110-125	150-165	110-125	115-130

* Information not available

GIBSON SYSTEM SPECIFICATIONS

MODELS	Compressor Type	Refrigerant (R134a) Oz.	Suction Pressure - PSIG				High Side PSIG (Last 1/3 of cycle)		Wattage Range (Last 1/3 of cycle)	
			Ambient 70°F		Ambient 90°F		70°F	90°F	70°F	90°F
			Cut-In	Cut-Out	Cut-In	Cut-Out				
GFC05M0AW0	NDA30LACM	5.5	12	0	12	0	110-130	145-165	65-85	70-85
GFC05M0AW1	NDA30LACM	5.5	12	0	12	0	110-130	145-165	65-85	70-85
GFC05M3AW0	NDA30LACM	5.5	12	0	12	0	110-130	145-165	65-85	70-85
GFC05M3AW1	NDA30LACM	5.5	12	0	12	0	110-130	145-165	65-85	70-85
GFC07M3AW0	EMU45HSC	7	12	0	12	0	110-130	145-165	65-85	70-85
GFC07M3AW1	KX40LACM	6.5	12	0	12	0	110-130	145-165	65-85	70-85
GFC07M3AW2	KX40LACM	6.5	12	0	12	0	110-130	145-165	65-85	70-85
GFC09M3AW0	EMU45HSC	8	12	0	12	0	110-130	145-165	65-85	70-85
GFC09M3AW1	EMU45HSC	8	12	0	12	0	110-130	145-165	65-85	70-85
GFC15M3AW0	EMU60HSC	10	12	0	12	0	110-130	145-165	65-85	70-85
GFC15M4AW6	EM160HSC	10	14	0	14	0	100-115	140-155	90-105	100-115
GFC25M4AW0	EGU90HLCW	12.5	15	0	15	0	105-125	155-165	100-140	110-145
GFU14F3AW0	EMU60HSC	5.5	14	0	14	0	110-125	150-165	110-125	115-130
GFU14F3AW1	EMU60HSC	5.5	14	0	14	0	110-125	150-165	110-125	115-130
GFU17F5AW0	GRH207-1-3765	7.3	14	0	14	0	100-115	140-155	115-140	120-145
GFU17F5AW1	GRH207-1-3765	7.3	14	0	14	0	100-115	140-155	115-140	120-145
GFU17M3AW0	EHU70HLC	7.5	14	0	14	0	110-125	155-170	105-120	110-125
GFU17M3AW1	TPE1370YXA	7.5	14	0	14	0	110-125	155-170	105-120	110-125
GFU20F5AW0	GRH208-1-3767	7.5	14	0	14	0	100-115	140-155	115-140	120-145
GFU20F5AW1	GRH208-1-3767	7.5	14	0	14	0	100-115	140-155	115-140	120-145
GFU21M3AW0	GRH107-1-3764	9	14	0	14	0	110-125	155-170	105-120	110-125
GFU21M6AW0	GRH107-1-3764	9	14	0	14	0	110-125	155-170	105-120	110-125
GFU21M6AW1	GRH107-1-3764	9	14	0	14	0	110-125	155-170	105-120	110-125
GFU21M6AW2	GRH107-1-3764	9	14	0	14	0	110-125	155-170	105-120	110-125
GRU17B2JW0	EM30HNR	6	*	*	*	*	*	*	*	*
GRU17B2JW1	EM30HNR	6	*	*	*	*	*	*	*	*
GRU17B2JW2	EM30HNR	6	*	*	*	*	*	*	*	*
GRU17B2JW4	EM30HNR	6	*	*	*	*	*	*	*	*
GRU17B2JW5	EM30HNR	6	*	*	*	*	*	*	*	*

* Information not available

UNIVERSAL / MULTIFLEX SYSTEM SPECIFICATIONS

MODELS	Compressor Type	Refrigerant (R134a) Oz.	Suction Pressure - PSIG				High Side PSIG (Last 1/3 of cycle)		Wattage Range (Last 1/3 of cycle)	
			Ambient 70°F		Ambient 90°F		70°F	90°F	70°F	90°F
			Cut-In	Cut-Out	Cut-In	Cut-Out				
CFC05M0AW0	NDA30LACM	5.5	12	0	12	0	110-130	145-165	65-85	70-85
CFC05M0AW1	NDA30LACM	5.5	12	0	12	0	110-130	145-165	65-85	70-85
CFC07M1AW0	EMU45HSC	7	12	0	12	0	110-130	145-165	65-85	70-85
CFC07M1AW2	KX40LACM	6.5	12	0	12	0	110-130	145-165	65-85	70-85
CFC07M4AW0	EMU45HSC	7	12	0	12	0	110-130	145-165	65-85	70-85
CFC07M4AW2	KX40LACM	6.5	12	0	12	0	110-130	145-165	65-85	70-85
CFC09M4AW0	EMU45HSC	8	12	0	12	0	110-130	145-165	65-85	70-85
CFC09M4AW1	EMU45HSC	8	12	0	12	0	110-130	145-165	65-85	70-85
CFC09M5AW0	EMU45HSC	8	12	0	12	0	110-130	145-165	65-85	70-85
CFC13M5AW0	EMU60HSC	9	15	0	15	0	95-110	140-155	85-100	95-110
CFC13M5AW1	EMU60HSC	9	15	0	15	0	95-110	140-155	85-100	95-110
CFU09M2AW0	NSB30LBCM	7	15	0	15	0	105-115	140-160	70-110	70-110
CFU09M2AW1	NSB30LBCM	7	15	0	15	0	105-115	140-160	70-110	70-110
CFU12M2AW0	ND40LBCM	7	15	0	15	0	105-115	140-160	70-110	70-110
CFU12M2AW1	ND40LBCM	7	15	0	15	0	105-115	140-160	70-110	70-110
CFU14M2AW0	EMU60HSC	8	15	0	15	0	105-115	140-160	70-110	70-110
CFU14M2AW1	EMU60HSC	8	15	0	15	0	105-115	140-160	70-110	70-110
CFU17F3AW0	GRH207-1-3765	7.3	14	0	14	0	100-115	140-155	115-140	120-145

VENEX SYSTEM SPECIFICATIONS

ER1411	RG213-1-3734	6	*	*	*	*	*	*	*	*
ER1412	RG213-1-3734	6	*	*	*	*	*	*	*	*
ER148	RG213-1-3734	6.5	*	*	*	*	*	*	*	*
VC200	RF108-1-3701	6	*	*	*	*	*	*	*	*
VV2010	RF108-1-3701	6	*	*	*	*	*	*	*	*
VV2011	RF108-1-3701	6	*	*	*	*	*	*	*	*

WHITE WESTINGHOUSE SYSTEM SPECIFICATIONS

WFC20M3AW0	EGU80HLCW	11	15	0	15	0	105-125	155-165	100-140	110-145
WFC25M3AW0	EGU90HLCW	12.5	15	0	15	0	105-125	155-165	100-140	110-145

* Information not available

BROICH SCHEMATIC INDEX LIST

Model	Service Data Sheet	Electrical Diagram	Relay/Overload	System Schematic
CF051	*	*	*	*
CF052	*	*	*	*
CF071	*	*	*	*
CF091	*	*	*	*
CF092	*	*	*	*
CF133	*	*	*	*
CF153	*	*	*	*
CF183	*	*	*	*
F22CW10	*	*	*	*
F22CW11	*	*	*	*
GTCF050	*	*	*	*
GTCF051	*	*	*	*
R22CW9	*	*	*	*
UL1293CA1	*	*	*	*
UL1793CA1	216803200	EC40 / Page 27	C26 / Page 30	SS1 / Page31
UL1793CA2	216803200	EC40 / Page 27	C26 / Page 30	SS1 / Page31
UL2100CA0	216803200	EC40 / Page 27	C26 / Page 30	SS1 / Page31
UL2494CA0	216803200	EC40 / Page 27	C26 / Page 30	SS1 / Page31
UL400CA0	216803200	EC40 / Page 27	C26 / Page 30	SS1 / Page31
UL5000CA0	216803200	EC40 / Page 27	C26 / Page 30	SS1 / Page31
UL5000CA1	216803300	EC48 / Page 28	C26 / Page 30	SS5 / Page31
UL5000CA4	216803300	EC48 / Page 28	C26 / Page 30	SS5 / Page31

EDINA TECH SCHEMATIC INDEX LIST

FMR8	216724900	EC6 / Page 27	C9 / Page 30	*
------	-----------	---------------	--------------	---

* Information not available

FRIGIDAIRE SCHEMATIC INDEX LIST

Model	Service Data Sheet	Electrical Diagram	Relay/Overload	System Schematic
FFC04M0AW1	216787900	EC69 / Page 28	C10 / Page 30	SP21 / Page 32
FFC05C2AW0	216787900	EC69 / Page 28	C10 / Page 30	SP21 / Page 32
FFC05C2AW1	216787900	EC69 / Page 28	C10 / Page 30	SP21 / Page 32
FFC05K0AW0	216787900	EC69 / Page 28	C10 / Page 30	SP21 / Page 32
FFC05K0AW1	216787900	EC69 / Page 28	C10 / Page 30	SP21 / Page 32
FFC05M0AW0	216787900	EC69 / Page 28	C10 / Page 30	SP21 / Page 32
FFC05M0AW1	216787900	EC69 / Page 28	C10 / Page 30	SP21 / Page 32
FFC05M2AW0	216787900	EC69 / Page 28	C10 / Page 30	SP21 / Page 32
FFC05M2AW1	216787900	EC69 / Page 28	C10 / Page 30	SP21 / Page 32
FFC07C2AW0	216787900	EC69 / Page 28	C10 / Page 30	SP21 / Page 32
FFC07C3AW0	216787900	EC69 / Page 28	C10 / Page 30	SP21 / Page 32
FFC07C3AW1	216787900	EC69 / Page 28	C10 / Page 30	SP21 / Page 32
FFC07C3AW2	216787900	EC69 / Page 28	C10 / Page 30	SP21 / Page 32
FFC07C4AW0	216787900	EC69 / Page 28	C10 / Page 30	SP21 / Page 32
FFC07C4AW1	216787900	EC69 / Page 28	C10 / Page 30	SP21 / Page 32
FFC07C4AW2	216787900	EC69 / Page 28	C10 / Page 30	SP21 / Page 32
FFC07K0AW0	216787900	EC69 / Page 28	C10 / Page 30	SP21 / Page 32
FFC07K0AW1	216787900	EC69 / Page 28	C10 / Page 30	SP21 / Page 32
FFC07K0AW2	216787900	EC69 / Page 28	C10 / Page 30	SP21 / Page 32
FFC07M2AW0	216787900	EC69 / Page 28	C10 / Page 30	SP21 / Page 32
FFC07M2AW1	216787900	EC69 / Page 28	C10 / Page 30	SP21 / Page 32
FFC07M2AW2	216787900	EC69 / Page 28	C10 / Page 30	SP21 / Page 32
FFC09C2AW0	216787900	EC69 / Page 28	C10 / Page 30	SP21 / Page 32
FFC09C3AW0	216787900	EC69 / Page 28	C10 / Page 30	SP21 / Page 32
FFC09C3AW1	216787900	EC69 / Page 28	C10 / Page 30	SP21 / Page 32
FFC09C4AW0	216787900	EC69 / Page 28	C10 / Page 30	SP21 / Page 32
FFC09C4AW1	216787900	EC69 / Page 28	C10 / Page 30	SP21 / Page 32
FFC09C7AW0	216787900	EC69 / Page 28	C10 / Page 30	SP21 / Page 32

FRIGIDAIRE SCHEMATIC INDEX LIST

Model	Service Data Sheet	Electrical Diagram	Relay/Overload	System Schematic
FFC09C7AW1	216787900	EC69 / Page 28	C10 / Page 30	SP21 / Page 32
FFC09M2AW0	216787900	EC69 / Page 28	C10 / Page 30	SP21 / Page 32
FFC09M2AW1	216787900	EC69 / Page 28	C10 / Page 30	SP21 / Page 32
FFC13C2AW0	216803900	EC69 / Page 28	C10 / Page 30	SS1 / Page 31
FFC13C3AW0	216803900	EC69 / Page 28	C10 / Page 30	SS1 / Page 31
FFC13C4AW0	216803900	EC69 / Page 28	C10 / Page 30	SS1 / Page 31
FFC13C4AW1	216803900	EC69 / Page 28	C10 / Page 30	SS1 / Page 31
FFC13C7AW0	216803900	EC69 / Page 28	C10 / Page 30	SS1 / Page 31
FFC13C7AW1	216803900	EC69 / Page 28	C10 / Page 30	SS1 / Page 31
FFC13K1AW0	216803900	EC69 / Page 28	C10 / Page 30	SS1 / Page 31
FFC13M2AW0	216803900	EC69 / Page 28	C10 / Page 30	SS1 / Page 31
FFC13M2AW1	216803900	EC69 / Page 28	C10 / Page 30	SS1 / Page 31
FFC15C2AW0	216803900	EC69 / Page 28	C10 / Page 30	SS1 / Page 31
FFC15C3AW0	216803900	EC69 / Page 28	C10 / Page 30	SS1 / Page 31
FFC15C4AW0	216803900	EC69 / Page 28	C10 / Page 30	SS1 / Page 31
FFC15C4AW1	216803900	EC69 / Page 28	C10 / Page 30	SS1 / Page 31
FFC15C7AW0	216803900	EC69 / Page 28	C10 / Page 30	SS1 / Page 31
FFC15C7AW1	216803900	EC69 / Page 28	C10 / Page 30	SS1 / Page 31
FFC15M4AW0	216803900	EC69 / Page 28	C10 / Page 30	SS1 / Page 31
FFC15M4AW1	216803900	EC69 / Page 28	C10 / Page 30	SS1 / Page 31
FFC20C3AW0	216804000	EC69 / Page 28	C10 / Page 30	SS10 / Page 32
FFC20C4AW0	216804000	EC69 / Page 28	C10 / Page 30	SS10 / Page 32
FFC20D5AW0	216804000	EC69 / Page 28	C10 / Page 30	SS10 / Page 32
FFC25C3AW0	216804000	EC69 / Page 28	C10 / Page 30	SS10 / Page 32
FFC25C4AW0	216804000	EC69 / Page 28	C10 / Page 30	SS10 / Page 32
FFU09K0AW0	216803100	EC40 / Page 27	C26 / Page 30	SS1 / Page 31
FFU09K0AW1	216803100	EC40 / Page 27	C26 / Page 30	SS1 / Page 31
FFU09K0AW2	216803100	EC40 / Page 27	C26 / Page 30	SS1 / Page 31

FRIGIDAIRE SCHEMATIC INDEX LIST

Model	Service Data Sheet	Electrical Diagram	Relay/Overload	System Schematic
FFU09M2AW0	216803100	EC40 / Page 27	C26 / Page 30	SS1 / Page 31
FFU09M2AW1	216803100	EC40 / Page 27	C26 / Page 30	SS1 / Page 31
FFU09M2AW2	216803100	EC40 / Page 27	C26 / Page 30	SS1 / Page 31
FFU11F3AW0	216803500	EC33 / Page 27	C10 / Page 30	SS8 / Page 32
FFU11FK2AW0	216803500	EC33 / Page 27	C10 / Page 30	SS8 / Page 32
FFU11FK2AW1	216803500	EC33 / Page 27	C10 / Page 30	SS8 / Page 32
FFU11FK2AW2	216803500	EC33 / Page 27	C10 / Page 30	SS8 / Page 32
FFU12C2AW0	216803100	EC40 / Page 27	C26 / Page 30	SS1 / Page 31
FFU12M2AW0	216803100	EC40 / Page 27	C26 / Page 30	SS1 / Page 31
FFU12M2AW1	216803100	EC40 / Page 27	C26 / Page 30	SS1 / Page 31
FFU12M2AW2	216803100	EC40 / Page 27	C26 / Page 30	SS1 / Page 31
FFU14C2AW0	216803100	EC40 / Page 27	C26 / Page 30	SS1 / Page 31
FFU14C4AW0	216803100	EC40 / Page 27	C26 / Page 30	SS1 / Page 31
FFU14F3AW0	216803600	EC41 / Page 28	C10 / Page 30	SS8 / Page 32
FFU14F3AW1	216803600	EC41 / Page 28	C10 / Page 30	SS8 / Page 32
FFU14F3AW2	216803600	EC41 / Page 28	C10 / Page 30	SS8 / Page 32
FFU14FC3AW0	216803600	EC41 / Page 28	C10 / Page 30	SS8 / Page 32
FFU14FC4AW0	216803600	EC41 / Page 28	C10 / Page 30	SS8 / Page 32
FFU14M2AW0	216803100	EC40 / Page 27	C26 / Page 30	SS1 / Page 31
FFU14M2AW1	216803100	EC40 / Page 27	C26 / Page 30	SS1 / Page 31
FFU17C2AW0	216803200	EC40 / Page 27	C26 / Page 30	SS1 / Page 31
FFU17C3AW0	216803200	EC40 / Page 27	C26 / Page 30	SS1 / Page 31
FFU17C3AW1	216803200	EC40 / Page 27	C26 / Page 30	SS1 / Page 31
FFC17C4AW0	216803200	EC40 / Page 27	C26 / Page 30	SS1 / Page 31
FFU17F3AW0	216803700	EC41 / Page 28	C10 / Page 30	SS8 / Page 32
FFU17FC3AW0	216803700	EC41 / Page 28	C10 / Page 30	SS8 / Page 32
FFU17C4AW0	216803700	EC41 / Page 28	C10 / Page 30	SS8 / Page 32

FRIGIDAIRE SCHEMATIC INDEX LIST

Model	Service Data Sheet	Electrical Diagram	Relay/Overload	System Schematic
FFU17M2AW0	216803200	EC40 / Page 27	C26 / Page 30	SS1 / Page 31
FFU20F3AW0	216803100	EC40 / Page 27	C26 / Page 30	SS1 / Page 31
FFU20F3AW1	216803700	EC41 / Page 28	C10 / Page 30	SS8 / Page 32
FFU20F3AW2	216803700	EC41 / Page 28	C10 / Page 30	SS8 / Page 32
FFU20FC3AW0	216803700	EC41 / Page 28	C10 / Page 30	SS8 / Page 32
FFU20FC4AW0	216803700	EC41 / Page 28	C10 / Page 30	SS8 / Page 32
FFU20FC6AW0	216803700	EC41 / Page 28	C10 / Page 30	SS8 / Page 32
FFU20FC6AW1	216803700	EC41 / Page 28	C10 / Page 30	SS8 / Page 32
FFU20FC6AW2	216803700	EC41 / Page 28	C10 / Page 30	SS8 / Page 32
FFU21C2AW0	216803200	EC40 / Page 27	C26 / Page 30	SS1 / Page 31
FFU21C3AW0	216803200	EC40 / Page 27	C26 / Page 30	SS1 / Page 31
FFU21C5AW0	216803200	EC40 / Page 27	C26 / Page 30	SS1 / Page 31
FFU21C5AW1	216803200	EC40 / Page 27	C26 / Page 30	SS1 / Page 31
FFU21M2AW0	216803200	EC40 / Page 27	C26 / Page 30	SS1 / Page 31
FRU17B2JW0	216758400	EC82 / Page 29	C9 / Page 30	SP24 / Page 33
FRU17B2JW1	216758400	EC82 / Page 29	C9 / Page 30	SP24 / Page 33
FRU17B2JW3	216758400	EC82 / Page 29	C9 / Page 30	SP24 / Page 33
FRU17B2JW4	216758400	EC82 / Page 29	C9 / Page 30	SP24 / Page 33
FRU17B2JW6	216758400	EC82 / Page 29	C9 / Page 30	SP24 / Page 33
FRU17G4JW0	216758400	EC82 / Page 29	C9 / Page 30	SP24 / Page 33
FRU17G4JW1	216758400	EC82 / Page 29	C9 / Page 30	SP24 / Page 33
FRU17G4JW2	216758400	EC82 / Page 29	C9 / Page 30	SP24 / Page 33
FRU17G4JW3	216758400	EC82 / Page 29	C9 / Page 30	SP24 / Page 33
FRU17G4JW4	216758400	EC82 / Page 29	C9 / Page 30	SP24 / Page 33
FRU17G4JW5	216758400	EC82 / Page 29	C9 / Page 30	SP24 / Page 33
FRU17G4JW6	216758400	EC82 / Page 29	C9 / Page 30	SP24 / Page 33
MFC07M1BW5	216372500	EC1 / Page 27	C9 / Page 30	SP24 / Page 33
MFC07M3FW4	216372500	EC1 / Page 27	C9 / Page 30	SP24 / Page 33

FRIGIDAIRE SCHEMATIC INDEX LIST

Model	Service Data Sheet	Electrical Diagram	Relay/Overload	System Schematic
MFC09M3FW2	216372500	EC1 / Page 27	C9 / Page 30	SS3 / Page 31
MFC09M3FW3	216372500	EC1 / Page 27	C9 / Page 30	SS3 / Page 31
MFC20M4FW4	216651200	EC69 / Page 28	C10 / Page 30	SS1 / Page 31
MFU14M2GW4	216576600	EC40 / Page 27	C23 / Page 30	SS1 / Page 31
MFU14M2GW5	216803100	EC40 / Page 27	C26 / Page 30	SS1 / Page 31

FRIGIDAIRE (GALLERY) SCHEMATIC INDEX LIST

FFC07G4AW0	216787900	EC69 / Page 28	C10 / Page 30	SP21 / Page 32
FFC07G4AW1	216787900	EC69 / Page 28	C10 / Page 30	SP21 / Page 32
FFC09G7AW0	216787900	EC69 / Page 28	C10 / Page 30	SP21 / Page 32
FFC13G7AW0	216803900	EC69 / Page 28	C10 / Page 30	SS1 / Page 31
FFC15G7AW0	216803900	EC69 / Page 28	C10 / Page 30	SS1 / Page 31
FFC20G4AW0	216804000	EC69 / Page 28	C10 / Page 30	SS10 / Page 32
FFC25G4AW0	216804000	EC69 / Page 28	C10 / Page 30	SS10 / Page 32
FFU14G4AW0	216803600	EC41 / Page 28	C10 / Page 30	SS1 / Page 31

GIBSON SCHEMATIC INDEX LIST

GFC05M0AW0	216787900	EC69 / Page 28	C10 / Page 30	SP21 / Page 32
GFC05M0AW1	216787900	EC69 / Page 28	C10 / Page 30	SP21 / Page 32
GFC05M3AW0	216787900	EC69 / Page 28	C10 / Page 30	SP21 / Page 32
GFC05M3AW1	216787900	EC69 / Page 28	C10 / Page 30	SP21 / Page 32
GFC07M3AW0	216787900	EC69 / Page 28	C10 / Page 30	SP21 / Page 32
GFC07M3AW1	216787900	EC69 / Page 28	C10 / Page 30	SP21 / Page 32
GFC07M3AW2	216787900	EC69 / Page 28	C10 / Page 30	SP21 / Page 32
GFC09M3AW0	216787900	EC69 / Page 28	C10 / Page 30	SP21 / Page 32
GFC09M3AW1	216787900	EC69 / Page 28	C10 / Page 30	SP21 / Page 32
GFC15M3AW0	216803900	EC69 / Page 28	C10 / Page 30	SS1 / Page 32
GFC15M4AW6	216651600	EC1 / Page 27	C10 / Page 30	SS10 / Page32
GFC25M4AW0	216804000	EC69 / Page 28	C10 / Page 30	SS10 / Page 32
GFU14F3AW0	216803600	EC41 / Page 28	C10 / Page 30	SS8 / Page 32

GIBSON SCHEMATIC INDEX LIST

Model	Service Data Sheet	Electrical Diagram	Relay/Overload	System Schematic
GFU14F3AW1	216803600	EC41 / Page 28	C10 / Page 30	SS8 / Page 32
GFU17F5AW0	216803800	EC41 / Page 28	C10 / Page 30	SS8 / Page 32
GFU17F5AW1	216803800	EC41 / Page 28	C10 / Page 30	SS8 / Page 32
GFU17M3AW0	216803200	EC40 / Page 27	C26 / Page 30	SS1 / Page 31
GFU17M3AW1	216803200	EC40 / Page 27	C26 / Page 30	SS1 / Page 31
GFU20F5AW0	216803800	EC41 / Page 28	C10 / Page 30	SS8 / Page 32
GFU20F5AW1	216803800	EC41 / Page 28	C10 / Page 30	SS8 / Page 32
GFU21M3AW0	216803200	EC40 / Page 27	C26 / Page 30	SS1 / Page 31
GFU21M6AW0	216803200	EC40 / Page 27	C26 / Page 30	SS1 / Page 31
GFU21M6AW1	216803200	EC40 / Page 27	C26 / Page 30	SS1 / Page 31
GFU21M6AW2	216803200	EC40 / Page 27	C26 / Page 30	SS1 / Page 31
GRU17B2JW0	216758400	EC82 / Page 29	C9 / Page 30	SP24 / Page 33
GRU17B2JW1	216758400	EC82 / Page 29	C9 / Page 30	SP24 / Page 33
GRU17B2JW2	216758400	EC82 / Page 29	C9 / Page 30	SP24 / Page 33
GRU17B2JW4	216758400	EC82 / Page 29	C9 / Page 30	SP24 / Page 33
GRU17B2JW5	216758400	EC82 / Page 29	C9 / Page 30	SP24 / Page 33

UNIVERSAL / MULTIFLEX SCHEMATIC INDEX LIST

CFC05M0AW0	216787900	EC69 / Page 28	C10 / Page 30	SP21 / Page 32
CFC05M0AW1	216787900	EC69 / Page 28	C10 / Page 30	SP21 / Page 32
CFC07M1AW0	216787900	EC69 / Page 28	C10 / Page 30	SP21 / Page 32
CFC07M1AW2	216787900	EC69 / Page 28	C10 / Page 30	SP21 / Page 32
CFC07M4AW0	216787900	EC69 / Page 28	C10 / Page 30	SP21 / Page 32
CFC07M4AW2	216787900	EC69 / Page 28	C10 / Page 30	SP21 / Page 32
CFC09M4AW0	216787900	EC69 / Page 28	C10 / Page 30	SP21 / Page 32
CFC09M4AW1	216787900	EC69 / Page 28	C10 / Page 30	SP21 / Page 32
CFC09M5AW0	216787900	EC69 / Page 28	C10 / Page 30	SP21 / Page 32
CFC13M5AW0	216803900	EC69 / Page 28	C10 / Page 30	SS1 / Page 31
CFC13M5AW1	216803900	EC69 / Page 28	C10 / Page 30	SS1 / Page 31

UNIVERSAL / MULTIFLEX SCHEMATIC INDEX LIST				
Model	Service Data Sheet	Electrical Diagram	Relay/Overload	System Schematic
CFU09M2AW0	216803100	EC40 / Page 27	C26 / Page 30	SS1 / Page 31
CFU09M2AW1	216803100	EC40 / Page 27	C26 / Page 30	SS1 / Page 31
CFU12M2AW0	216803100	EC40 / Page 27	C26 / Page 30	SS1 / Page 31
CFU12M2AW1	216803100	EC40 / Page 27	C26 / Page 30	SS1 / Page 31
CFU14M2AW0	216803100	EC40 / Page 27	C26 / Page 30	SS1 / Page 31
CFU14M2AW1	216803100	EC40 / Page 27	C26 / Page 30	SS1 / Page 31
CFU17F3AW1	216803700	EC41 / Page 28	C10 / Page 30	SS8 / Page 32
VENEX INC. SCHEMATIC INDEX LIST				
ER1411	216607700	EC58 / Page 28	C1 / Page 30	*
ER1412	216607700	EC58 / Page 28	C1 / Page 30	*
ER148	216607700	EC58 / Page 28	C1 / Page 30	*
VC200	216754000	EC29 / Page 27	C28 / Page 30	*
VV2010	216754000	EC29 / Page 27	C28 / Page 30	*
VV2011	216754000	EC29 / Page 27	C28 / Page 30	*
WHITE WESTINGHOUSE SCHEMATIC INDEX LIST				
WFC20M3AW0	216804000	EC69 /Page 28	C10 / Page 30	SS10 / Page 32
WFC25M3AW0	216804000	EC69 /Page 28	C10 / Page 30	SS10 / Page 32

* Information not available.

ELECTRICAL CIRCUITS

EC1

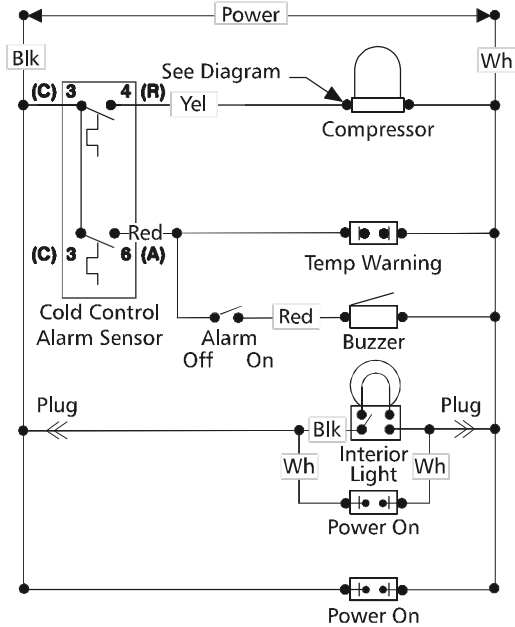

EC6

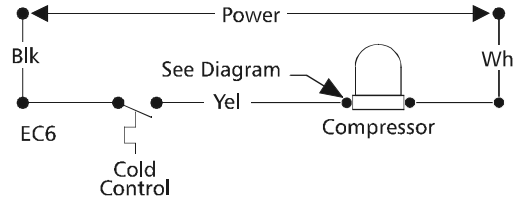

EC33

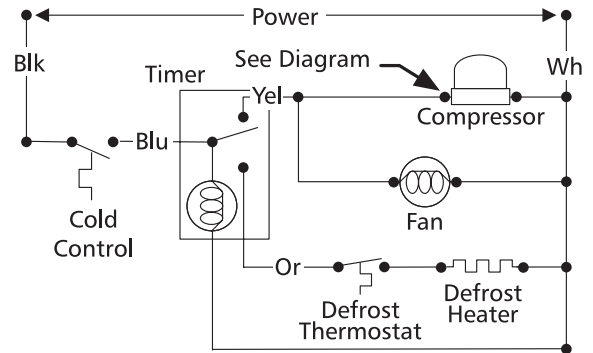

EC29

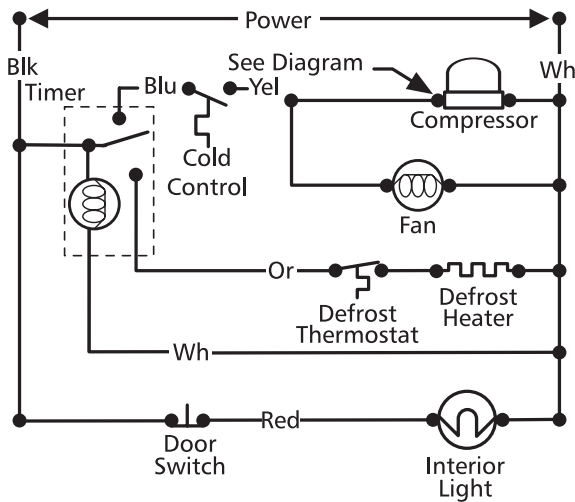

EC40

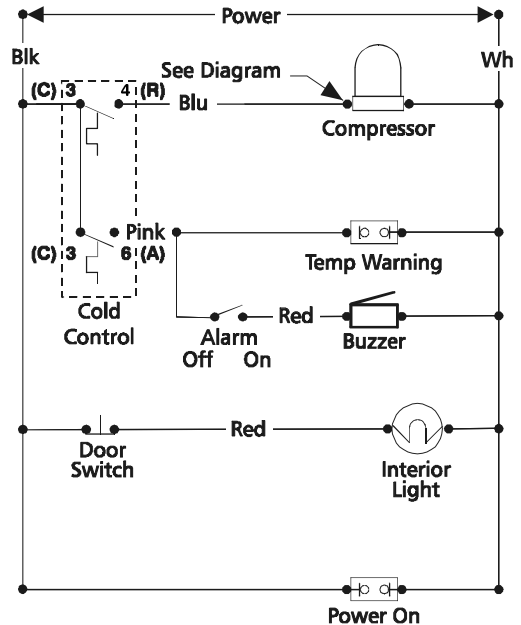

ELECTRICAL CIRCUITS

EC41

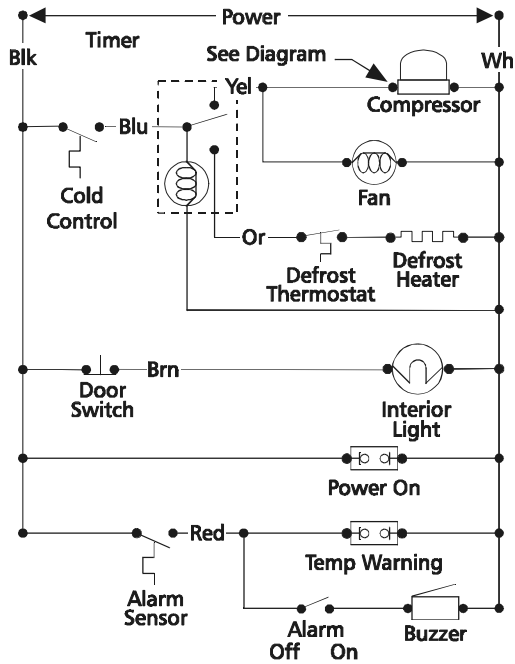

EC58

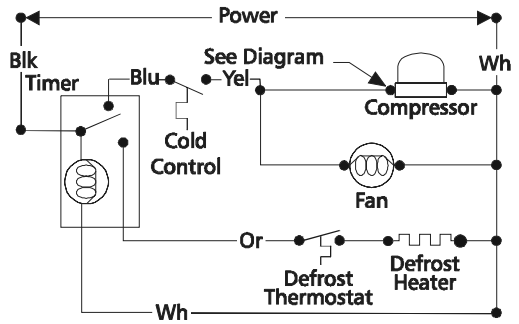

EC69

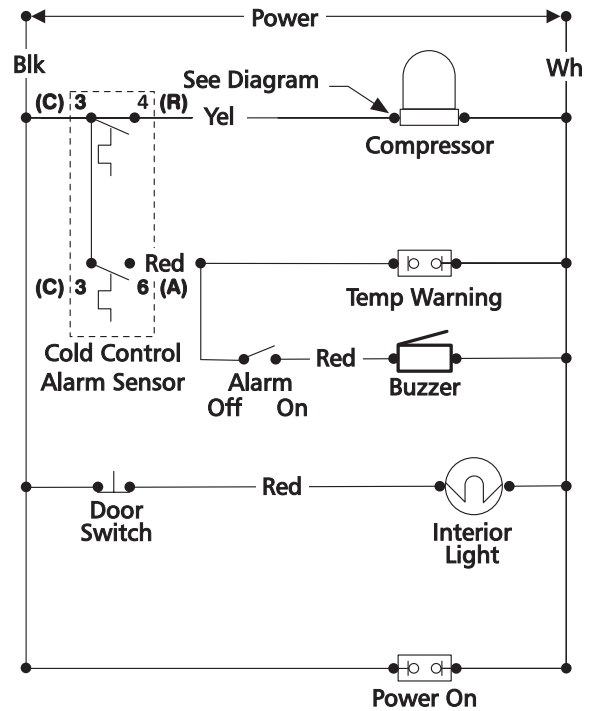

EC48

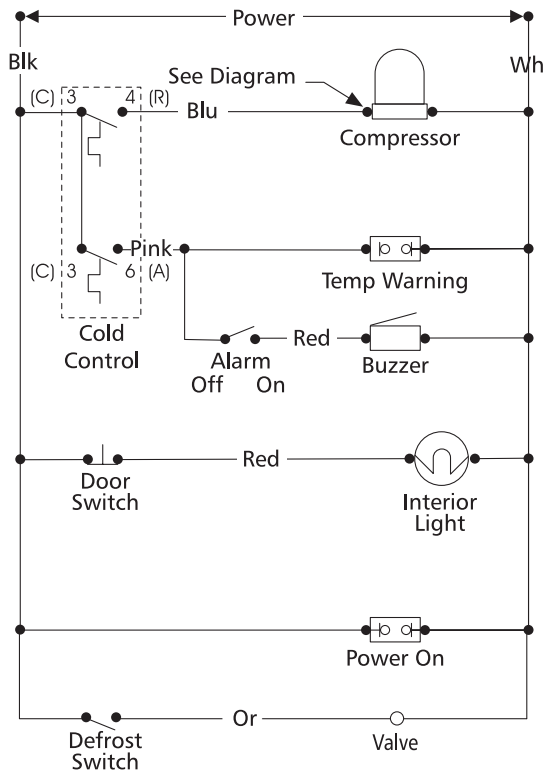

ELECTRICAL CIRCUITS

EC82

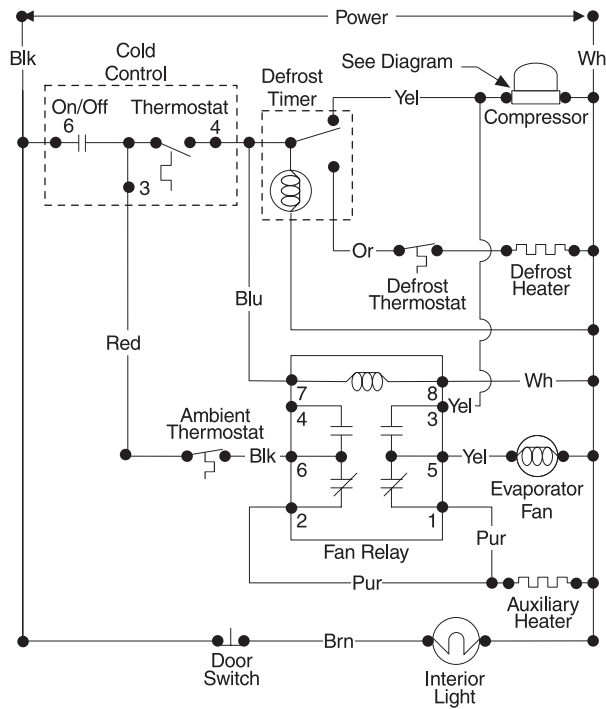

RELAY / OVERLOAD SCHEMATICS

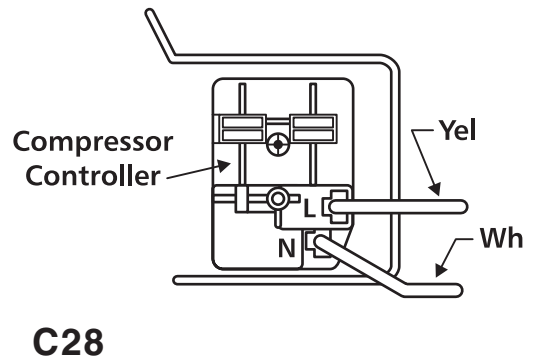
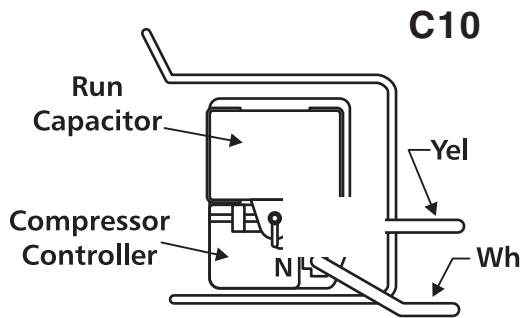
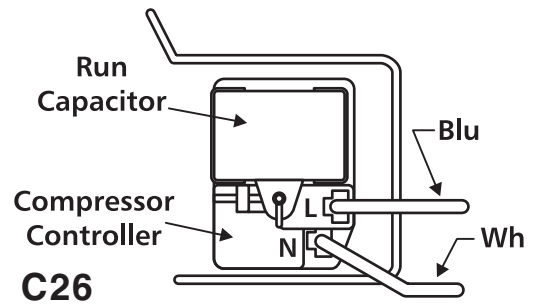
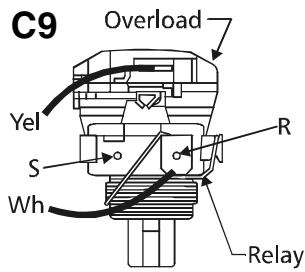
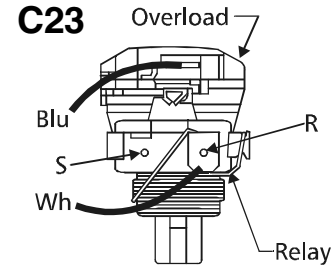
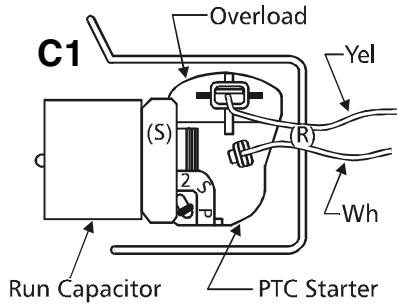

SYSTEM SCHEMATICS

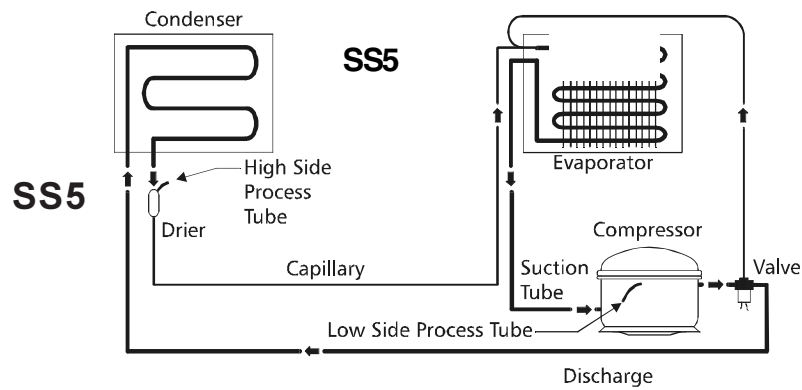
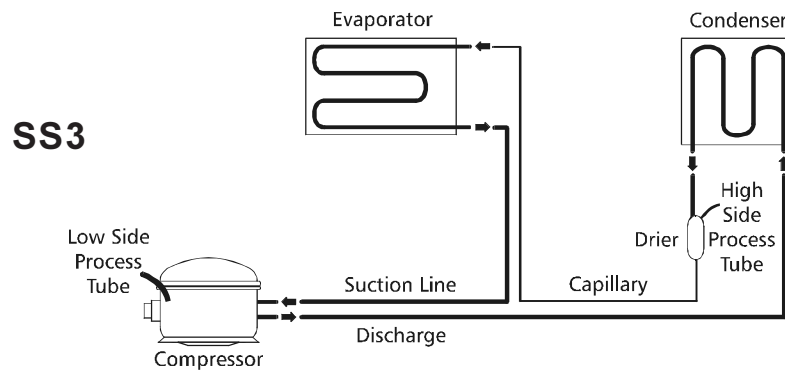
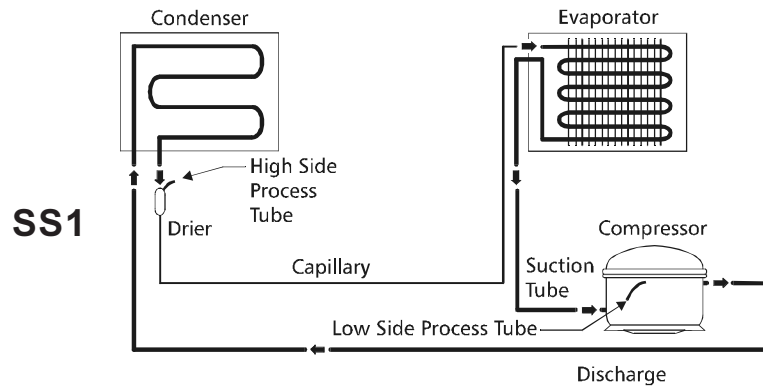

SYSTEM SCHEMATICS

SS8

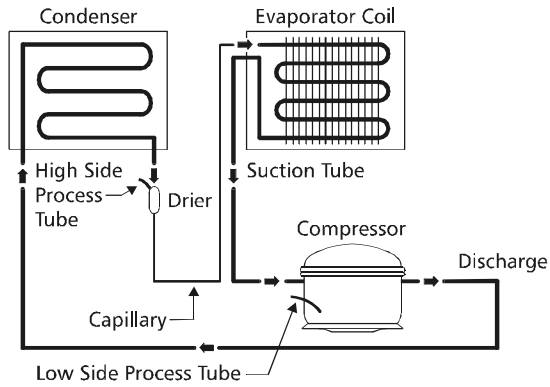

SYSTEM SCHEMATIC

SS10

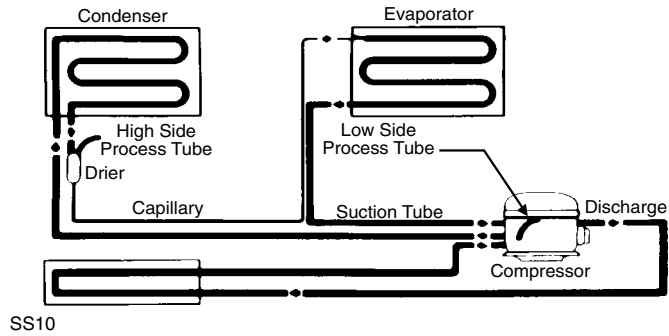

SYSTEM SCHEMATIC

SP21

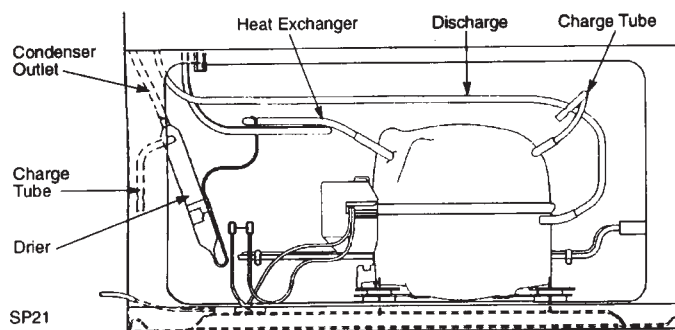

SYSTEM SCHEMATICS

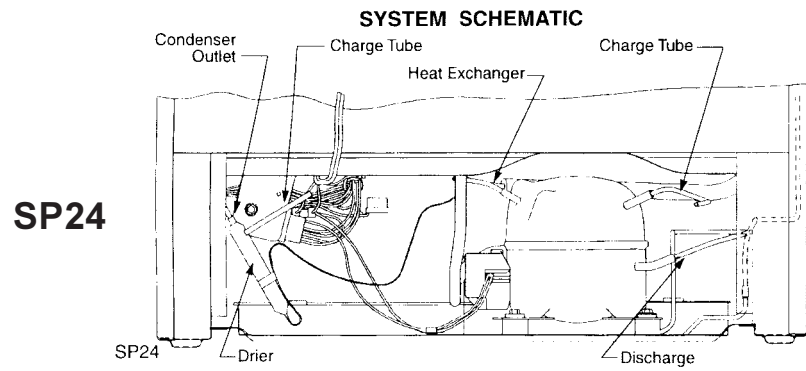

TROUBLESHOOTING GUIDE

PROBLEM	CAUSE	REMEDY
Compressor will not run	No voltage at wall receptacle.	Check circuit breaker, fuse or GFCI (Ground Fault Circuit Interruptor).
	Service cord defective or unplugged at wall receptacle.	Check cord.
	Low voltage causing compressor to cycle on overload.	Voltage fluctuation should not exceed $\pm 10\%$ of 115 VAC (104 - 127 VAC)
	Control thermostat knob in the "OFF" position.	Turn control thermostat knob to the "ON" position.
	Inoperative control thermostat.	Replace control thermostat.
	Compressor stuck.	Replace compressor.
	Compressor windings open.	Replace compressor.
	Defrost Timer stuck in defrost mode. (Frost Free models only)	Replace Defrost Timer.
	Compressor overload stuck open.	Replace compressor overload.
	Relay lead loose.	Repair or replace lead.
	Relay loose or inoperative.	Replace relay.
	Service cord pulled out of harness.	Repair connection.
	Faulty cabinet wiring.	Repair wiring.
	Compressor runs but no refrigeration.	System out of refrigerant.
Compressor not pumping.		Replace compressor.
Restricted Filter-Drier		Replace Filter-Drier.
Redstricted capillary tube.		Replace heat exchanger and evaporator assembly on Upright freezers. On Chest freezers, contact the Customer Assistance Center for product replacement.
Moisture in system.		Repair or replace component that is leaking. Replace the compressor if the system is contaminated. Blow out remaining part of system with Dry Nitrogen. Pump down and recharge.
Compressor short cycles.	Erratic control thermostat.	Replace control thermostat.
	Faulty relay.	Replace relay.
	Restricted air flow over cabinet. (Condenser is in cabinet.)	Leave a 3" space on all sides of the freezer for adequate circulation of air around freezer.

TROUBLESHOOTING GUIDE

PROBLEM	CAUSE	REMEDY
Compressor short cycles. (continued)	Low voltage. Fluctuations exceeds $\pm 10\%$ if 115 VAC. (104 - 127 VAC)	Call a qualified electrician.
	Compressor draws excessive wattage.	Replace compressor.
Compressor runs too much.	Erratic control thermostat, or improperly set.	Replace control thermostat or reset to normal position.
	Freezer exposed to unusual heat.	Relocate freezer.
	High room temperature (110° or higher)	Advise customer.
	Low pumping capacity compressor.	Replace compressor.
	Door gaskets not sealing.	Adjust or replace necessary parts.
	System undercharged.	Check for leaks.
	System overcharged.	Correct charge.
	Interior light stays on.	Check door switch.
	Non-condensables in system.	Flush out system. Replace filter-drier, evacuate and recharge.
	Capillary tube kinked or partially restricted.	Replace heat exchanger and evaporator assembly on Upright freezers. On chest freezers, contact the Customer Assistance Center for product replacement.
	Filter-Drier partially restricted.	Replace filter-drier.
	Excessive service load.	Advise customer.
Restricted air flow over cabinet. (Condenser is in cabinet.)	Leave a 3" space around all sides of the freezer for adequate circulation of air around freezer.	
Noisy	Tubing vibrates.	Adjust tubing.
	Internal compressor noise.	Replace compressor.
	Loose parts.	Check shelving, kickplate and defrost pan.
	Compressor operating at high head pressure due to restricted air flow over cabinet. (Condenser is in cabinet.)	Leave a 3" space around all sides of the freezer for adequate circulation of air around freezer.
	Inoperative evaporator fan motor.	Check wiring and evaporator fan motor.

TROUBLESHOOTING GUIDE

PROBLEM	CAUSE	REMEDY
Freezer compartment too warm	Improperly positioned fan.	Position fan 1/8" from leading edge of fan blade to freezer lines on Frost Free models. On manual defrost models, advise customer.
	Evaporated frosted up.	Check defrost system on Frost Free models. On manual defrost models, advise customer.
	Restricted air flow over cabinet. (Condenser is in cabinet.)	Leave a 3" space around all sides of the freezer for adequate circulation of air around freezer.
	Excessive service load.	Advise customer.
	High room temperatures. (110° or higher)	Advise customer.
	Freezer compartment door left open.	Advise customer.
	Control thermostat out of calibration.	Replace control thermostat.
	Door gasket not sealing.	Adjust or replace necessary parts.
	Control thermostat capillary tube improperly positioned.	Reposition sensing element.
	Shortage of refrigerant	Advise customer.
	Restricted filter-drier or capillary tube.	Check for leaks or burnt compressor windings.
Evaporator blocked with ice (Automatic defrost models)	Inoperative defrost timer.	Check wiring and defrost timer.
	Defrost thermostat terminates too early.	Check for correct positioning of defrost thermostat, or replace.
	Defrost timer wired incorrectly.	Check wiring.
	Inoperative fan motor.	Check wiring and fan motor.
	Inoperative defrost thermostat.	Check wiring and defrost thermostat.
	Inoperative defrost heater.	Check wiring and defrost heater.
	Freezer door left open.	Advise customer.
	Freezer defrost drain plugged.	Clean drain port.

