

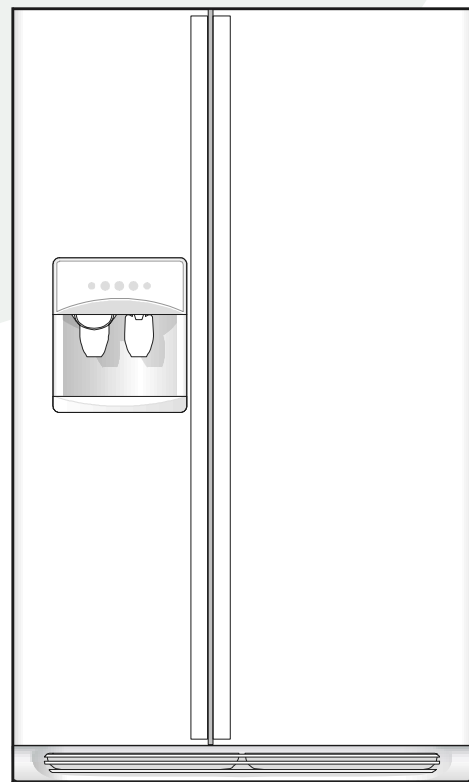

ELECTROLUX HOME PRODUCTS NORTH AMERICA

Product Information and Technical Guide

*Side by Side Refrigerators
October 1999 - May 2001*



Frigidaire[®]

TAPPAN[®]

W White-Westinghouse[®]

Kelvinator[®] 

Gibson[®]

TABLE OF CONTENTS

SAFE SERVICING PRACTICES	2
SERVICE DATA SHEET AND REFRIGERANT CHARGE INDEXES	
Frigidaire	3 - 10
Gibson	11
Multiflex / Universal *	12 - 13
Tappan	13
White-Westinghouse	13
TROUBLESHOOTING GUIDE	14 - 18
SERVICE DATA SHEETS	19 - 36

* Universal / Multiflex models can be sold under any of the Electrolux Home Products-NA brand names

SAFE SERVICING PRACTICES - ALL APPLIANCES

To avoid personal injury and/or property damage, it is important that **Safe Servicing Practices** be observed. The following are some limited examples of safe practices:

1. **DO NOT** attempt a product repair if you have any doubts as to your ability to complete it in a safe and satisfactory manner.
2. Before servicing or moving an appliance:
 - Remove the power cord from the electrical outlet, trip the circuit breaker to the OFF position, or remove the fuse.
 - Turn off the gas supply.
 - Turn off the water supply.
3. Never interfere with the proper operation of any safety device.
4. **USE ONLY REPLACEMENT PARTS CATALOGED FOR THIS APPLIANCE. SUBSTITUTIONS MAY DEFEAT COMPLIANCE WITH SAFETY STANDARDS SET FOR HOME APPLIANCES.**
5. **GROUNDING:** The standard color coding for safety ground wires is **GREEN**, or **GREEN** with **YELLOW STRIPES**. Ground leads are not to be used as current carrying conductors. It is **EXTREMELY** important that the service technician reestablish all safety grounds prior to completion of service. Failure to do so will create a hazard.
6. Prior to returning the product to service, ensure that:
 - All electrical connections are correct and secure
 - All electrical leads are properly dressed and secured away from sharp edges, high-temperature components, and moving parts
 - All non-insulated electrical terminals, connectors, heaters, etc. are adequately spaced away from all metal parts and panels
 - All safety grounds (both internal and external) are correctly and securely connected
 - All panels are properly and securely reassembled

ATTENTION!!!

This service manual is intended for use by persons having electrical and mechanical training and a level of knowledge of these subjects generally considered acceptable in the appliance repair trade. Electrolux Home Products cannot be responsible, nor assume any liability, for injury or damage of any kind arising from the use of this manual.

FRIGIDAIRE MODELS				
Model	Service Data Sheets		R-134a Refrigerant Charge (ounces)	Energy Efficiency Rating (kwh/yr)
	Number	Pages		
FRS20QRCD6	218768300	19 - 20	4.5	783
FRS20QRCD7	218768300	19 - 20	4.5	783
FRS20QRCD8	218768300	19 - 20	4.5	783
FRS20QRCD9	218768301	21 - 22	4	783
FRS20QRCW6	218768300	19 - 20	4.5	783
FRS20QRCW7	218768300	19 - 20	4.5	783
FRS20QRCW8	218768300	19 - 20	4.5	783
FRS20QRCW9	218768301	21 - 22	4	783
FRS20WRHD4	218905000	23 - 24	4.5	916
FRS20WRHD5	218905000	23 - 24	4.5	916
FRS20WRHD6	218905001	25 - 26	4	916
FRS20WRHW4	218905000	23 - 24	4.5	916
FRS20WRHW5	218905000	23 - 24	4.5	916
FRS20WRHW6	218905001	25 - 26	4	916
FRS20ZGJB0	218909400	27 - 28	4.5	916
FRS20ZGJB1	218909400	27 - 28	4	916
FRS20ZGJB2	218909401	29 - 30	4	916
FRS20ZGJD0	218909400	27 - 28	4.5	916
FRS20ZGJD1	218909401	29 - 30	4	916
FRS20ZGJD2	218909401	29 - 30	4	916
FRS20ZGJW0	218909400	27 - 28	4.5	916
FRS20ZGJW1	218909401	29 - 30	4	916
FRS20ZGJW2	218909401	29 - 30	4	916
FRS20ZRGB6	218909400	27 - 28	4.5	916

FRIGIDAIRE MODELS				
Model	Service Data Sheets		R-134a Refrigerant Charge (ounces)	Energy Efficiency Rating (kwh/yr)
	Number	Pages		
FRS20ZRGB7	218909400	27 - 28	4.5	916
FRS20ZRGB8	218909400	27 - 28	4.5	916
FRS20ZRGB9	218909401	29 - 30	4	916
FRS20ZRGDA	218909401	29 - 30	5	916
FRS20ZRGD6	218909400	27 - 28	4.5	916
FRS20ZRGD7	218909400	27 - 28	4.5	916
FRS20ZRGD8	218909400	27 - 28	4.5	916
FRS20ZRGD9	218909401	29 - 30	4	916
FRS20ZRGDA	218909401	29 - 30	4	916
FRS20ZRGW6	218909400	27 - 28	4.5	916
FRS20ZRGW7	218909400	27 - 28	4.5	916
FRS20ZRGW8	218909400	27 - 28	4.5	916
FRS20ZRGW9	218909401	29 - 30	4	916
FRS20ZRGWA	218909401	29 - 30	4	916
FRS20ZSHB3	218909400	27 - 28	4.5	916
FRS20ZSHB4	218909401	29 - 30	4	916
FRS20ZSHB5	218909401	29 - 30	4	916
FRS22ZGHB3	218909400	27 - 28	5	966
FRS22ZGHB4	218909400	27 - 28	5	966
FRS22ZGHB5	218909401	29 - 30	4.5	966
FRS22ZGHB6	218909401	29 - 30	4.5	966
FRS22ZGHW3	218909400	27 - 28	5	966
FRS22ZGHW4	218909400	27 - 28	5	966
FRS22ZGHW5	218909400	27 - 28	5	966

FRIGIDAIRE MODELS				
Model	Service Data Sheets		R-134a Refrigerant Charge (ounces)	Energy Efficiency Rating (kwh/yr)
	Number	Pages		
FRS22ZGHW6	218909401	29 - 30	4.5	966
FRS22ZRHD3	218909400	28 - 29	5	966
FRS22ZRHW3	218909400	28 - 29	5	966
FRS23F5AW0	240389603	35 - 36	5	686
FRS23KF7AB1	240389603	35 - 36	5	686
FRS23KF7AQ1	240389603	35 - 36	5	686
FRS23KF7AW0	240389603	35 - 36	5	686
FRS23KF7AW1	240389603	35 - 36	5	686
FRS23KFR4AB0	240389603	35 - 36	5	686
FRS23KFR4AB1	240389603	35 - 36	5	686
FRS23KFR4AQ1	240389603	35 - 36	5	686
FRS23KFR4AW0	240389600	31 - 32	5	686
FRS23KFR4AW1	240389603	35 - 36	5	686
FRS23R3AW0	240389603	35 - 36	5	686
FRS23R4AB0	240389603	35 - 36	5	686
FRS23R4AQ0	240389603	35 - 36	5	686
FRS23R4AQ1	240389603	35 - 36	5	686
FRS23R4AW0	240389603	35 - 36	5	686
FRS23R4AW1	240389603	35 - 36	5	686
FRS23W2AW0	240389603	35 - 36	5	686
FRS23W3AQ0	240389600	31 - 32	5	686
FRS23W3AQ1	240389603	35 - 36	5	686
FRS23W3AW0	240389600	31 - 32	5	686
FRS23W3AW1	240389601	33 - 34	5	686

FRIGIDAIRE MODELS				
Model	Service Data Sheets		R-134a Refrigerant Charge (ounces)	Energy Efficiency Rating (kwh/yr)
	Number	Pages		
FRS23X3AW0	240389600	31 - 32	5	686
FRS23X5AW0	240389601	33 - 34	5	686
FRS23X5AW1	240389601	33 - 34	5	686
FRS23ZTJB0	218909400	27 - 28	5	966
FRS23ZTJB2	218909401	29 - 30	4.5	966
FRS23ZTJQ0	218909400	27 - 28	5	966
FRS23ZTJQ2	218909401	29 - 30	4.5	966
FRS23ZTJW0	218909400	27 - 28	5	966
FRS23ZTJW1	218909401	29 - 30	4.5	966
FRS23ZTJW2	218909401	29 - 30	4.5	966
FRS24ZRHB3	218905000	23 - 24	5	998
FRS24ZRHD3	218905000	23 - 24	5	998
FRS24ZRHD4	218905001	25 - 26	4.5	998
FRS24ZRHD5	218905001	25 - 26	4.5	998
FRS24ZRHW3	218905000	23 - 24	5	998
FRS24ZRHW4	218905001	25 - 26	4.5	998
FRS24ZRHW5	218905001	25 - 26	4.5	998
FRS26F5AQ0	240389603	35 - 36	5.25	728
FRS26F5AW0	240389603	35 - 36	5.25	728
FRS26F7AW0	240389603	35 - 36	5.25	728
FRS26KR4JQ0	218909400	27 - 28	5	1025
FRS26KR4JQ1	218909401	29 - 30	4.5	1025
FRS26KR4JW0	218909400	27 - 28	5	1025
FRS26KR4JW1	218909401	29 - 30	4.5	1025

FRIGIDAIRE MODELS				
Model	Service Data Sheets		R-134a Refrigerant Charge (ounces)	Energy Efficiency Rating (kwh/yr)
	Number	Pages		
FRS26KW3AQ0	240389603	35 - 36	5.25	728
FRS26R4AW0	240389603	35 - 36	5.25	728
FRS26WQHD1	218909400	27 - 28	5	1025
FRS26WQHD2	218909401	29 - 30	4.5	1025
FRS26WQHW1	218909400	27 - 28	5	1025
FRS26WQHW2	218909401	29 - 30	4.5	1025
FRS26ZGHB	218909401	29 - 30	5	1025
FRS26ZGHB2	218909400	27 - 28	5	1025
FRS26ZGHB3	218909400	27 - 28	5	1025
FRS26ZGHB4	218909401	29 - 30	4.5	1025
FRS26ZGHB5	218909401	29 - 30	4.5	1025
FRS26ZGHD2	218909400	27 - 28	5	1025
FRS26ZGHD3	218909400	27 - 28	5	1025
FRS26ZGHD4	218909401	29 - 30	4.5	1025
FRS26ZGHW2	218909400	27 - 28	5	1025
FRS26ZGHW3	218909400	27 - 28	5	1025
FRS26ZGHW4	218909401	29 - 30	4.5	1025
FRS26ZGHW5	218909401	29 - 30	4.5	1025
FRS26ZNHB2	218909400	27 - 28	5	1025
FRS26ZNHB3	218909400	27 - 28	5	1025
FRS26ZNHB4	218909401	29 - 30	4.5	1025
FRS26ZNHB5	218909401	29 - 30	4.5	1025
FRS26ZNHD2	218909400	27 - 28	5	1025
FRS26ZNHD3	218909400	27 - 28	5	1025

FRIGIDAIRE MODELS				
Model	Service Data Sheets		R-134a Refrigerant Charge (ounces)	Energy Efficiency Rating (kwh/yr)
	Number	Pages		
FRS26ZNHD4	218909401	29 - 30	4.5	1025
FRS26ZNHD5	218909401	29 - 30	4.5	1025
FRS26ZNHW2	218909400	27 - 28	5	1025
FRS26ZNHW3	218909400	27 - 28	5	1025
FRS26ZNHW4	218909401	29 - 30	4.5	1025
FRS26ZNJSB0	218909400	27 - 28	5	1025
FRS26ZNJSB1	218909401	29 - 30	4.5	1025
FRS26ZNJSB2	218909401	29 - 30	4.5	1025
FRS26ZPHB2	218909400	27 - 28	5	1025
FRS26ZPHD2	218909400	27 - 28	5	1025
FRS26ZPHD3	218909401	29 - 30	4.5	1025
FRS26ZPHD4	218909401	29 - 30	4.5	1025
FRS26ZPHW1	218909400	27 - 28	5	1025
FRS26ZPHW2	218909400	27 - 28	5	1025
FRS26ZPHW3	218909401	29 - 30	4.5	1025
FRS26ZPHW4	218909401	29 - 30	4.5	1025
FRS26ZRGBA	218909400	27 - 28	5	1025
FRS26ZRGBB	218909401	29 - 30	4.5	1025
FRS26ZRIBC	218909401	29 - 30	4.5	1025
FRS26ZRGD9	218909400	27 - 28	5	1025
FRS26ZRGDA	218909400	27 - 28	5	1025
FRS26ZRGDB	218909401	29 - 30	4.5	1025
FRS26ZRGDC	218909401	29 - 30	4.5	1025
FRS26ZRGW9	218909400	27 - 28	5	1025

FRIGIDAIRE MODELS				
Model	Service Data Sheets		R-134a Refrigerant Charge (ounces)	Energy Efficiency Rating (kwh/yr)
	Number	Pages		
FRS26ZRGWA	218909400	27 - 28	5	1025
FRS26ZRGWB	218909401	29 - 30	4.5	1025
FRS26ZRGWC	218909401	29 - 30	4.5	1025
FRS26ZSHB2	218909400	27 - 28	5	1025
FRS26ZSHB3	218909400	27 - 28	5	1025
FRS26ZSHB4	218909401	29 - 30	4.5	1025
FRS26ZSHB5	218909401	29 - 30	4.5	1025
FRS26ZTHB2	218909400	27 - 28	5	1025
FRS26ZTHB3	218909400	27 - 28	5	1025
FRS26ZTHB4	218909401	29 - 30	4.5	1025
FRS26ZTHB5	218909401	29 - 30	4.5	1025
FRS26ZTHD2	218909400	27 - 28	5	1025
FRS26ZTHD3	218909400	27 - 28	5	1025
FRS26ZTHQ3	218909400	27 - 28	5	1025
FRS26ZTHQ4	218909401	29 - 30	4.5	1025
FRS26ZTHQ5	218909401	29 - 30	4.5	1025
FRS26ZTHW2	218909400	27 - 28	5	1025
FRS26ZTHW3	218909400	27 - 28	5	1025
FRS26ZTHW4	218909401	29 - 30	4.5	1025
FRS26ZTHW5	218909401	29 - 30	4.5	1025
FRS26ZXHW2	218909400	27 - 28	5	1025
F45ZR24JD0	218905000	23 - 24	5.0	998
F45ZR24JD1	218905001	25 - 26	4.5	998
F45ZR24JW0	218905000	23 - 24	5.0	998
F45ZR24JD1	218905001	25 - 26	4.5	998

FRIGIDAIRE MODELS				
Model	Service Data Sheets		R-134a Refrigerant Charge (ounces)	Energy Efficiency Rating (kwh/yr)
	Number	Pages		
GLRSF236JB0	218909400	27 - 28	5	966
GLRSF236JB1	218909401	29 - 30	4.5	966
GLRSF236JB2	218909401	29 - 30	4.5	966
GLRSF236JD0	218909400	27 - 28	5	966
GLRSF236JD1	218909401	29 - 30	4.5	966
GLRSF236JD2	218909401	29 - 30	4.5	966
GLRSF236JW0	218909400	27 - 28	5	966
GLRSF236JW1	218909401	29 - 30	4.5	966
GLRSF236JW2	218909401	29 - 30	4.5	966
GLRSF266JB0	218909400	27 - 28	5	1025
GLRSF266JB1	218909401	29 - 30	4.5	1025
GLRSF266JB2	218909401	29 - 30	4.5	1025
GLRSF266JD0	218909400	27 - 28	5	1025
GLRSF266JD1	218909401	29 - 30	4.5	1025
GLRSF266JD2	218909401	29 - 30	4.5	1025
GLRSF266JW0	218909400	27 - 28	5	1025
GLRSF266JW1	218909401	29 - 30	4.5	1025
GLRSF266JW2	218909401	29 - 30	4.5	1025

GIBSON MODELS				
Model	Service Data Sheets		R-134a Refrigerant Charge (ounces)	Energy Efficiency Rating (kwh/yr)
	Number	Pages		
GRS20HRHD2	218768300	19 - 20	4.5	783
GRS20HRHD4	218768301	21 - 22	4	783
GRS20HRHW1	218768300	19 - 20	4.5	783
GRS20HRHW2	218768300	19 - 20	4.5	783
GRS20HRHW3	218768300	19 - 20	4.5	783
GRS20HRHW4	218768301	21 - 22	4	783
GRS20ZRHD3	218909400	27 - 28	4.5	916
GRS20ZRHD4	218909400	27 - 28	4.5	916
GRS20ZRHD7	218909401	29 - 30	4	916
GRS20ZRHD8	218909401	29 - 30	4	916
GRS20ZRHW3	218909400	27 - 28	4.5	916
GRS20ZRHW4	218909400	27 - 28	4.5	916
GRS20ZRHW5	218909400	27 - 28	4.5	916
GRS20ZRHW6	218909400	27 - 28	4.5	916
GRS20ZRHW7	218909401	29 - 30	4	916
GRS20ZRHW8	218909401	29 - 30	4	916
GRS26ZRHD2	218909400	27 - 28	5	1025
GRS26ZRHD3	218909400	27 - 28	5	1025
GRS26ZRHD4	218909400	27 - 28	5	1025
GRS26ZRHD5	218909401	29 - 30	4.5	1025
GRS26ZRHD6	218909401	29 - 30	4.5	1025
GRS26ZRHW2	218909400	27 - 28	5	1025
GRS26ZRHW3	218909400	27 - 28	5	1025
GRS26ZRHW4	218909400	27 - 28	5	1025
GRS26ZRHW5	218909401	29 - 30	4.5	1025
GRS26ZRHW6	218909401	29 - 30	4.5	1025

MULTIFLEX - UNIVERSAL MODELS				
Model	Service Data Sheets		R-134a Refrigerant Charge	Energy Efficiency Rating (kwh/yr)
	Number	Pages		
MRS20HRADA	218768301	21 - 22	4.5	783
MRS20HRADB	218768300	19 - 20	4.5	783
MRS20HRADC	218768300	19 - 20	4.5	783
MRS20HRADD	218768301	21 - 22	4	783
MRS20HRAWA	218768300	19 - 20	4.5	783
MRS20HRAWB	218768300	19 - 20	4.5	783
MRS20HRAWC	218768300	19 - 20	4.5	783
MRS20HRAWD	218768301	21 - 22	4	783
MRS22WHHW4	218905001	25 - 26	4.5	920
MRS22WNGD5	218905000	23 - 24	5	920
MRS22WNGD6	218905000	23 - 24	5	920
MRS22WNGD7	218905001	25 - 26	4.5	920
MRS22WNGW5	218905000	23 - 24	5	920
MRS22WNGW6	218905000	23 - 24	5	920
MRS22WNGW7	218905001	25 - 26	4.5	920
MRS26LGJB0	218909400	27 - 28	5	1025
MRS26LGJB1	218909400	27 - 28	5	1025
MRS26LGJB2	218909401	29 - 30	4.5	1025
MRS26LGJB3	218909401	29 - 30	4.5	1025
MRS26LGJC0	218909400	27 - 28	5	1025
MRS26LGJC1	218909401	29 - 30	4.5	1025
MRS26LGJC2	218909401	29 - 30	4.5	1025
MRS26LGJQ1	218909400	27 - 28	5	1025
MRS26LGJQ2	218909401	29 - 30	4.5	1025

MULTIFLEX - UNIVERSAL MODELS				
Model	Service Data Sheets		R-134a Refrigerant Charge (ounces)	Energy Efficiency Rating (kwh/yr)
	Number	Pages		
MRS26LGJQ3	218909401	29 - 30	4.5	1025
MRS26LGJW0	218909400	27 - 28	5	1025
MRS26LGJW1	218909400	27 - 28	5	1025
MRS26LGJW2	218909401	29 - 30	4.5	1025
MRS26LGJW3	218909401	29 - 30	4.5	1025
TAPPAN MODELS				
Model	Service Data Sheets		R-134a Refrigerant Charge (ounces)	Energy Efficiency Rating (kwh/yr)
	Number	Pages		
TRS20WRHW3	218905000	23 - 24	4.5	916
TRS20WRHW4	218905000	23 - 24	4.5	916
TRS20WRHW5	218905001	25 - 26	4	916
WHITE - WESTINGHOUSE MODELS				
Model	Service Data Sheets		R-134a Refrigerant Charge (ounces)	Energy Efficiency Rating (kwh/yr)
	Number	Pages		
WRS20MQRCW0	218768301	21 - 22	4	783
WRS20WRHD4	218905000	23 - 24	4.5	916
WRS20WRHD5	218905001	25 - 26	4	916
WRS20WRHW4	218905000	23 - 24	4.5	916
WRS20WRHW5	218905001	25 - 26	4	916
WRS22WNHD4	218905000	23 - 24	4.5	920
WRS22WNHD5	218905001	25 - 26	4.5	920
WRS22WNHW4	218905000	23 - 24	5	920
WRS22WNHW5	218905001	25 - 26	4.5	920
WRS26MZRHW0	218905001	25 - 26	4.5	1025
WRS26MZRHW1	218905001	25 - 26	4.5	1025

TROUBLESHOOTING GUIDE

PROBLEM	CAUSE	SOLUTION
Compressor will not run.	No voltage at wall receptacle.	Check circuit breaker, fuse or ground fault circuit interruptors.
	Service cord defective, or unplugged at wall receptacle.	Check cord.
	Low voltage causing compressor to cycle on overload.	Voltage fluctuation should not exceed +/- 10% of 115vac. (104-127)
	Control thermostat knob in OFF position.	Turn control thermostat knob to ON position.
	Inoperative control thermostat.	Replace control thermostat.
	Compressor stuck.	Replace compressor.
	Compressor windings open.	Replace compressor.
	Defrost timer stuck in defrost mode.	Replace defrost timer.
	Compressor overload stuck open.	Replace compressor overload.
	Relay lead loose.	Repair or replace lead.
	Relay loose or inoperative.	Repair or replace relay.
	Service cord pulled out of harness.	Repair connection.
	Faulty cabinet wiring.	Repair wiring.
Compressor runs but does not cool.	System out of refrigerant.	Check for leaks. *
	Compressor not pumping.	Replace compressor. *
	Restricted filter drier.	Replace filter drier. *
	Restricted capillary tube.	Replace heat exchanger and evaporator assembly.
	Moisture in system.	See NOTE. *

- * NOTE:**
- Repair or replace component that is leaking.
 - Replace the compressor if the system is contaminated.
 - Blow out remaining part of system with dry Nitrogen.
 - Pump down and recharge per listing on product serial plate.
 - Always replace filter drier when repairing sealed system.

PROBLEM	CAUSE	SOLUTION
Compressor short cycles.	Erratic control thermostat.	Replace control thermostat.
	Faulty relay.	Replace relay.
	Restricted air flow over condenser.	Ensure unobstructed air flow over condenser.
	Low voltage ... fluctuation exceeds +/- 10% of 115vac (104 - 127)	Call qualified electrician.
	Compressor draws excessive watts.	Replace compressor.
Compressor runs too much.	Control thermostat is erratic, or not properly set.	Replace control thermostat or reset to normal position.
	Refrigerator exposed to high heat. (110° or higher)	Move refrigerator to cooler location.
	High room temperature. (110° or higher)	Advise customer not to install refrigerator where temperature will rise above 110°F because compressor will not maintain proper temperatures.
	Low pumping capacity compressor.	Replace compressor.
	Door gaskets not sealing.	Adjust doors or replace door gaskets.
	System undercharged.	Check for leaks. *
	System overcharged.	Charge per listing on product serial plate. *
	Interior light stays on.	Check door switch and door adjustment.
	Contaminents in system.	Flush out system. Replace filter drier, evacuate, and recharge. *
	Capillary tube kinked or partially restricted.	Replace heat exchanger and evaporator assembly. *
	Filter drier partially restricted.	Replace filter drier. *
	Refrigerator and/or freezer compartment overloaded; poor air circulation.	Advise customer.
	Restricted air flow over condenser.	Ensure unobstructed air flow over condenser.
	Condenser fan motor is inoperative. (forced air condenser models only)	Replace condenser fan motor.

* See NOTE at bottom of page 14

PROBLEM	CAUSE	SOLUTION
---------	-------	----------

Noisy.	Tubing vibrates.	Adjust tubing.
	Internal compressor noise.	Replace compressor.
	Loose parts.	Check shelving.
	Compressor operating at high head pressure due to restricted air flow over condenser.	Ensure unobstructed air flow over condenser.

Freezer compartment too warm.

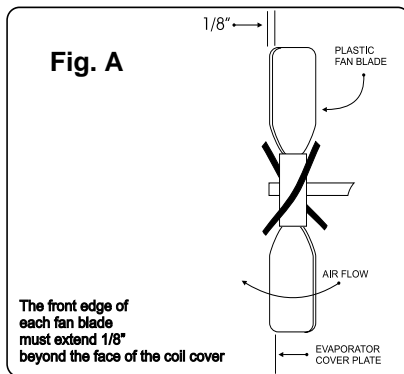

Inoperative evaporator fan motor.	Check wiring and evaporator fan motor.
Improperly positioned fan blade.	Position fan blade properly. See Figure A.
Evaporator frosted up.	Check defrost system, door adjustment, and door gaskets.
Inoperative condenser fan motor. (forced air condenser models only)	Replace condenser fan motor.
Restricted air flow over condenser.	Clean condenser.
Freezer compartment overloaded; poor air circulation.	Advise customer.
Low room temperature. (60° or lower, 55° for models with Service data Sheet numbers 240389600-4.)	Advise customer not to install refrigerator where temperature will drop below 60°F. Compressor will not maintain proper temperatures.
Freezer or refrigerator compartment doors left open.	Advise customer.
Control thermostat out of calibration.	Replace control thermostat.
Door gaskets not sealing.	Adjust doors or replace door gaskets.
Control thermostat capillary tube improperly positioned.	Reposition temperature sensing element.
Shortage of refrigerant.	Check for leaks. *
Restricted filter drier or capillary tube.	Check for leaks and burnt compressor windings. *

* See NOTE at bottom of page 14

PROBLEM	CAUSE	SOLUTION
Freezer compartment too cold.	Inoperative cold control.	Replace cold control.
	Freezer compartment inlet air duct is loose or restricted. Door is loose.	Re-install air duct or remove obstruction from inlet air duct. Adjust door.
	Food compartment air return duct blocked.	If foam block is frozen, replace block; if duct is blocked, remove obstruction.
	Diffuser (foam block) in top of food compartment is broken. (Foam block located in Control Housing for models with Service Data Sheets 240389600-4.)	Replace diffuser.
Refrigerator compartment too warm.	Inoperative evaporator fan motor.	Check wiring and evaporator fan motor.
	Improperly positioned evaporator fan blade.	Position fan blade properly. See page 15, Figure A.
	Refrigerator compartment inlet air duct loose or restricted. Door is loose.	Re-install air duct or remove obstruction from air duct. Adjust door.
	Freezer compartment return air duct restricted.	Remove obstruction from return air duct.
	Low room temperature. (60° or lower, 55° for models with Service data Sheet numbers 240389600-4.)	Advise customer not to install refrigerator where temperature will drop below 60°F. Compressor will not maintain proper temperatures.
	Damper control out of calibration.	Replace damper control.
	Control thermostat knob set at too warm a position.	Set control knob to a colder position.
	Evaporator frosted up.	Check defrost system, door adjustments, and door gaskets.
	Refrigerator compartment over-loaded; poor air circulation.	Advise customer.
	Refrigerator/freezer compartment doors left open.	Advise customer.
	Inoperative or erratic refrigerator/freezer compartment door switch.	Replace door switch.
Shortage of refrigerant.	Check for leaks. *	
Restricted capillary tube or filter drier.	Check for leaks or burnt compressor windings. *	

* See NOTE at bottom of page 14.

PROBLEM	CAUSE	SOLUTION
Refrigerator compartment too cold.	Inoperative cold control.	Replace cold control.
	Refrigerator compartment inlet air duct loose or restricted. Door is loose.	Re-install air duct or remove obstruction from air duct. Adjust door.
	Diffuser (foam block) in top of food compartment is broken.(Foam block located in Control Housing for models with Service Data Sheets 240389600-4.)	Replace diffuser.
Evaporator blocked with ice. (See Adaptive Defrost Control below for models with Service Data Sheet numbers 240389600-4.)	Inoperative defrost timer.	Check wiring. Repair or replace defrost timer.
	Defrost thermostat terminates too early. Thermostat is open.	Check for correct positioning of defrost thermostat. Repair or replace.
	Refrigerator/freezer compartment doors left open.	Advise customer.
	Heat exchanger and wiring harness openings not sealed.	Seal entrance hole with Permagum or (Food Safe) RTV.
Frozen drain.	Ice maker water line and wiring harness openings not sealed.	Seal water line and wiring harness openings.
	Drain trough not properly formed.	Ensure drain trough is at 90° angle to back of freezer and that lip is up on front and ends.
	Divider (foam block) frozen. (This does not apply for models with Service Data Sheet numbers 240389600-4.)	Replace divider. Check drain trough.
Adaptive Defrost Control (ADC) not responding correctly (Only for models having a Service Data Sheet number from 240389600-4.)	Faulty ADC board.	Replace ADC board.

SERVICE DATA SHEET

218768300

STANDARD - AUTOMATIC DEFROST

SIDE BY SIDE MODELS

PERFORMANCE DATA NO LOAD AND NO DOOR OPENINGS AT MID-POINT CONTROL SETTING				
Type A With Run/Start Capacitor	65°F Ambient	90°F Ambient		
Operating Time	37 to 45%	55 to 63%		
Freezer Temperature	-2° to 3°F	-2° to 4°F		
Refrigerator Temperature	34° to 39°F	34° to 39°F		
Low Side Pressure (cut-in)	5 to 12 psig	5 to 12 psig		
Low Side Pressure (cut-out)	-2 to 2 psig	-2 to 2 psig		
High Side Pressure (Last 1/3 of cycle)	110 to 130 psig	150 to 180 psig		
Wattage (Last 1/3 of cycle)	170 to 200	180 to 210		
Amps (Running)	1.5 to 1.8	1.5 to 1.8		
Base Voltage	115 VAC	115 VAC		
DEFROST SPECIFICATIONS				
Cabinet Size	Thermostat		Heater	
	Cut-in	Cut-out	Watts	Ohms
20'	+25°F	+47°F	550	24
22' to 28'	+25°F	+47°F	600	22
Defrost 30 Minutes Every 8 Hours of Compressor Run Time				
CONDENSER FAN MOTOR				
Watts	RPM	Amps		
2.3	1300 CW Opposite Shaft	.15 Running		
THERMOSTATIC DAMPER				
Full Open		Closed		
35°F +/- 2°F		22°F +/- 2°F		
ICE MAKER SPECIFICATIONS				
Electrical	115 Volts	60 Hertz		
Thermostat	Opens at 48°F	Closes at 15°F		
Heater Wattage	165			

IMPORTANT SAFETY NOTICE

The information provided herein is designed to assist qualified repair personnel only. Untrained persons should not attempt to make repairs due to the possibility of electrical shock. Disconnect power cord before servicing.

IMPORTANT

If any green grounding wires are moved during servicing, they must be returned to their original position and properly secured.

CAUTION: System parts must be removed from cabinet before brazing. All electrical parts and wiring must be shielded from torch flame. Do not allow torch to contact insulation; it will char at 200°F and flash ignite (burn) at 500°F. Excessive heat will distort the plastic liner.

ICE MAKER INFORMATION

Test Cycling

Remove cover by inserting screwdriver in notch at bottom and prying cover from housing. Use screwdriver to rotate motor gear counter-clockwise until holding switch circuit is completed. (See Figure 1.) All components of ice maker should function to complete the cycle.

Water Fill Volume

The water fill adjustment screw will change the fill time. (See Figure 1.) One full turn is equal to 20cc (.68 oz.). The correct fill is 90 to 120cc (3.0 to 4.0 oz.). When a water valve is replaced, the fill volume must be checked.

ATTENTION SERVICERS

Get a HELPING HAND by visiting the Electrolux Home Product Web Site where you can access Service Bulletins, New and Old Product Repair Tips, Service Kits, an interactive Service Request Form, and FAQ's. Visit the site at:

<http://www.frigidaire.com/tip>

User Name: service

Password: tip

And now available at <http://www.frigidaire.com> are the following:

- Wiring Diagrams
- Owner's Guides
- Installation Instructions
- Parts Catalogs

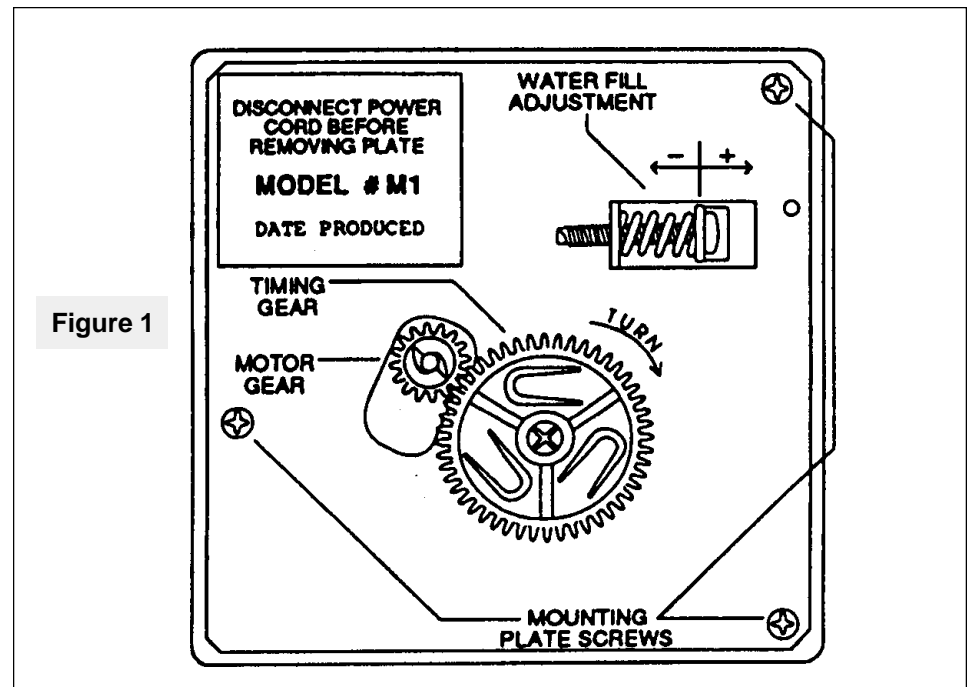
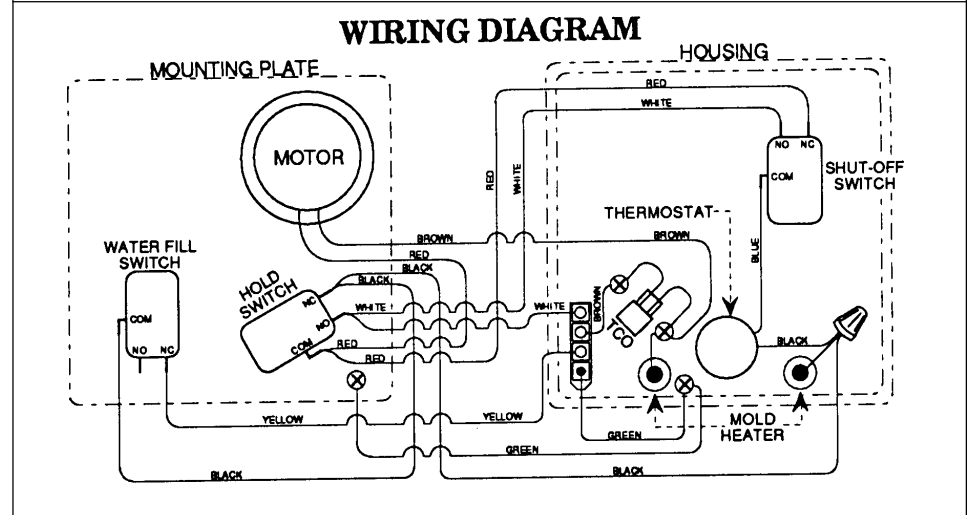
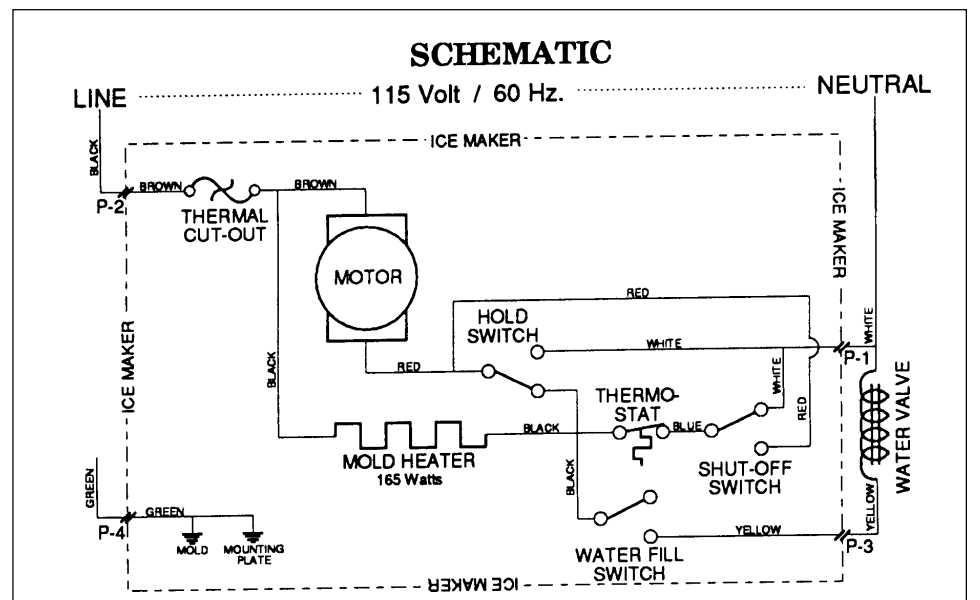
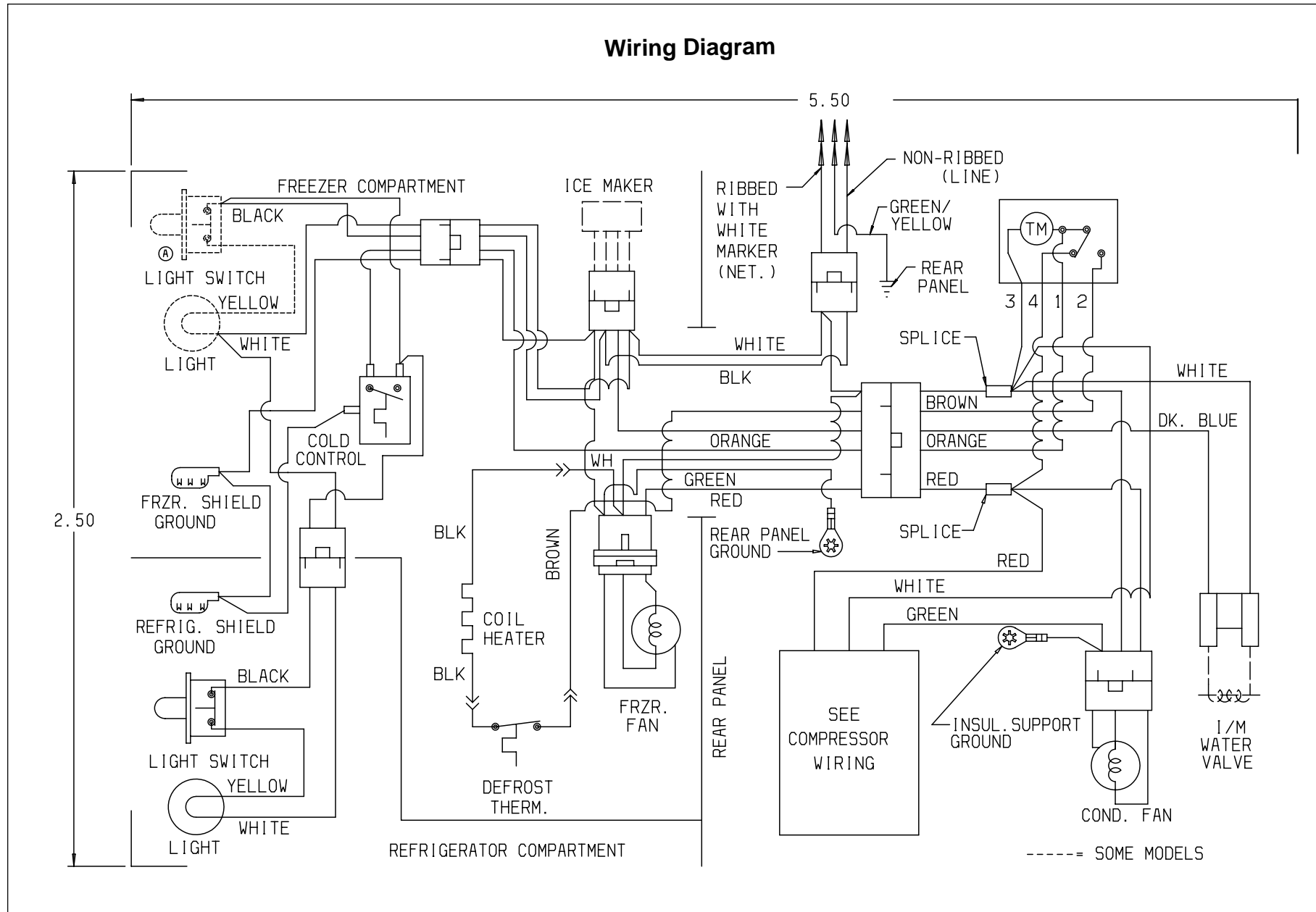

Figure 1



Wiring Diagram



Ladder Diagram

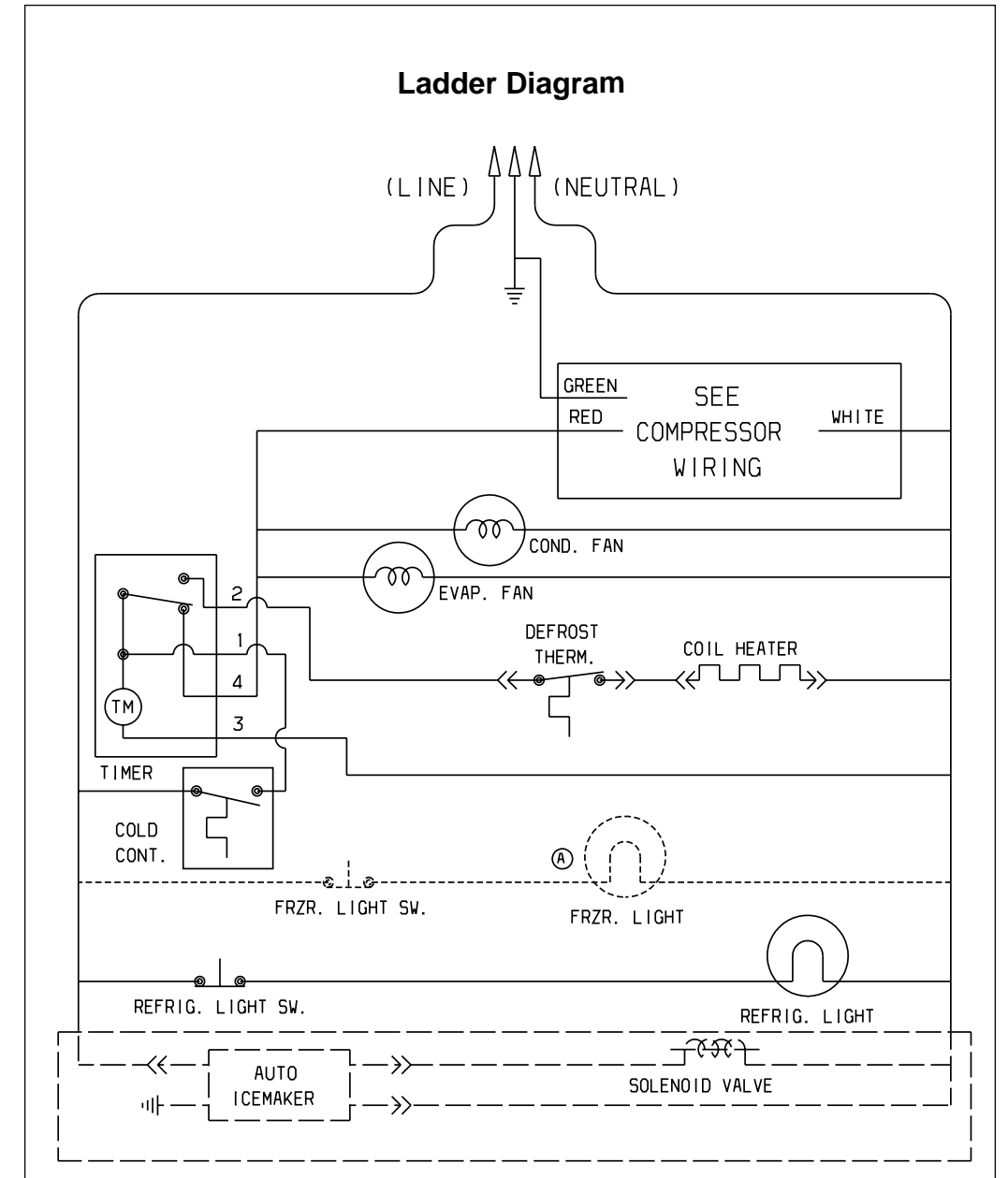

Compressor Wiring

P.T.C. STARTER WITH RUN CAPACITOR

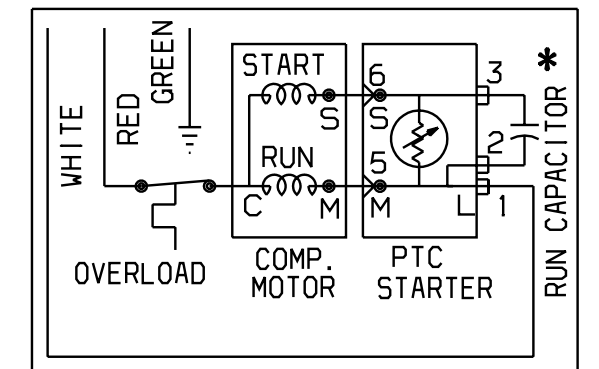

SERVICE DATA SHEET

218768301

STANDARD - AUTOMATIC DEFROST

SIDE BY SIDE MODELS

PERFORMANCE DATA NO LOAD AND NO DOOR OPENINGS AT MID-POINT CONTROL SETTING				
Type A With Run/Start Capacitor	65°F Ambient	90°F Ambient		
Operating Time	37 to 45%	55 to 63%		
Freezer Temperature	-2° to 3°F	-2° to 4°F		
Refrigerator Temperature	34° to 39°F	34° to 39°F		
Low Side Pressure (cut-in)	5 to 12 psig	5 to 12 psig		
Low Side Pressure (cut-out)	-2 to 2 psig	-2 to 2 psig		
High Side Pressure (Last 1/3 of cycle)	110 to 130 psig	150 to 180 psig		
Wattage (Last 1/3 of cycle)	170 to 200	180 to 210		
Amps (Running)	1.5 to 1.8	1.5 to 1.8		
Base Voltage	115 VAC	115 VAC		
DEFROST SPECIFICATIONS				
Cabinet Size	Thermostat		Heater	
	Cut-in	Cut-out	Watts	Ohms
20'	+25°F	+47°F	400	33
22' to 28'	+25°F	+47°F	450	30
Defrost 30 Minutes Every 8 Hours of Compressor Run Time				
CONDENSER FAN MOTOR				
Watts	RPM	Amps		
2.3	1300 CW Opposite Shaft	.15 Running		
THERMOSTATIC DAMPER				
Full Open		Closed		
35°F +/- 2°F		22°F +/- 2°F		
ICE MAKER SPECIFICATIONS				
Electrical	115 Volts	60 Hertz		
Thermostat	Opens at 48°F	Closes at 15°F		
Heater Wattage	165			

IMPORTANT SAFETY NOTICE

The information provided herein is designed to assist qualified repair personnel only. Untrained persons should not attempt to make repairs due to the possibility of electrical shock. Disconnect power cord before servicing.

IMPORTANT

If any green grounding wires are moved during servicing, they must be returned to their original position and properly secured.

CAUTION: System parts must be removed from cabinet before brazing. All electrical parts and wiring must be shielded from torch flame. Do not allow torch to contact insulation; it will char at 200°F and flash ignite (burn) at 500°F. Excessive heat will distort the plastic liner.

ICE MAKER INFORMATION

Test Cycling

Remove cover by inserting screwdriver in notch at bottom and prying cover from housing. Use screwdriver to rotate motor gear counter-clockwise until holding switch circuit is completed. (See Figure 1.) All components of ice maker should function to complete the cycle.

Water Fill Volume

The water fill adjustment screw will change the fill time. (See Figure 1.) One full turn is equal to 20cc (.68 oz.). The correct fill is 90 to 120cc (3.0 to 4.0 oz.). When a water valve is replaced, the fill volume must be checked.

ATTENTION SERVICERS

Get a HELPING HAND by visiting the Electrolux Home Product Web Site where you can access Service Bulletins, New and Old Product Repair Tips, Service Kits, an interactive Service Request Form, and FAQ's. Visit the site at:

<http://www.frigidaire.com/tip>

User Name: service

Password: tip

And now available at <http://www.frigidaire.com> are the following:

- Wiring Diagrams
- Owner's Guides
- Installation Instructions
- Parts Catalogs

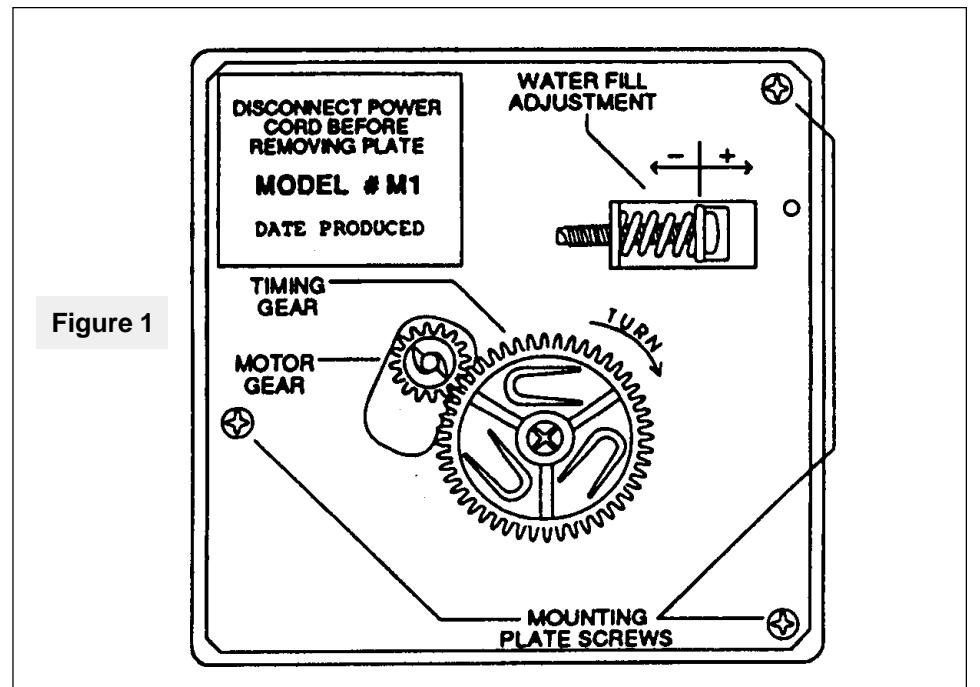
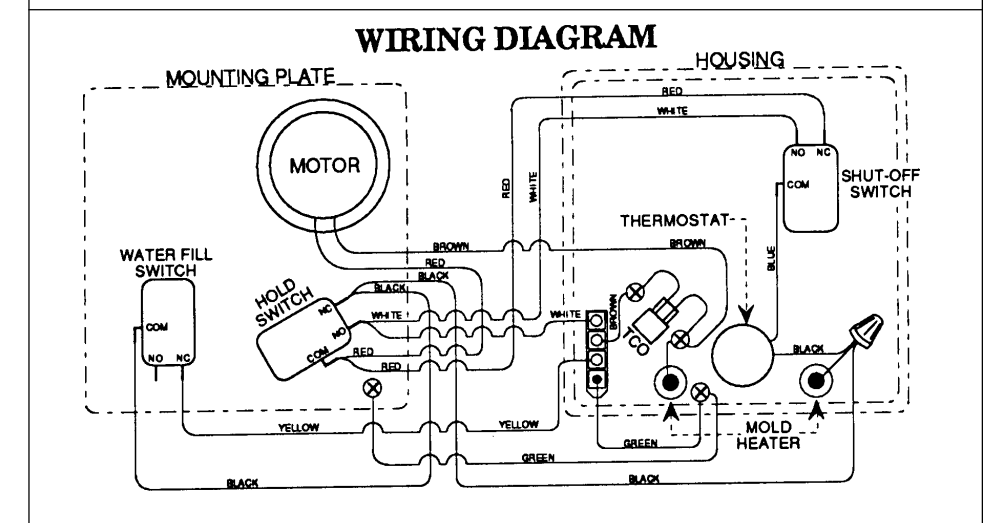
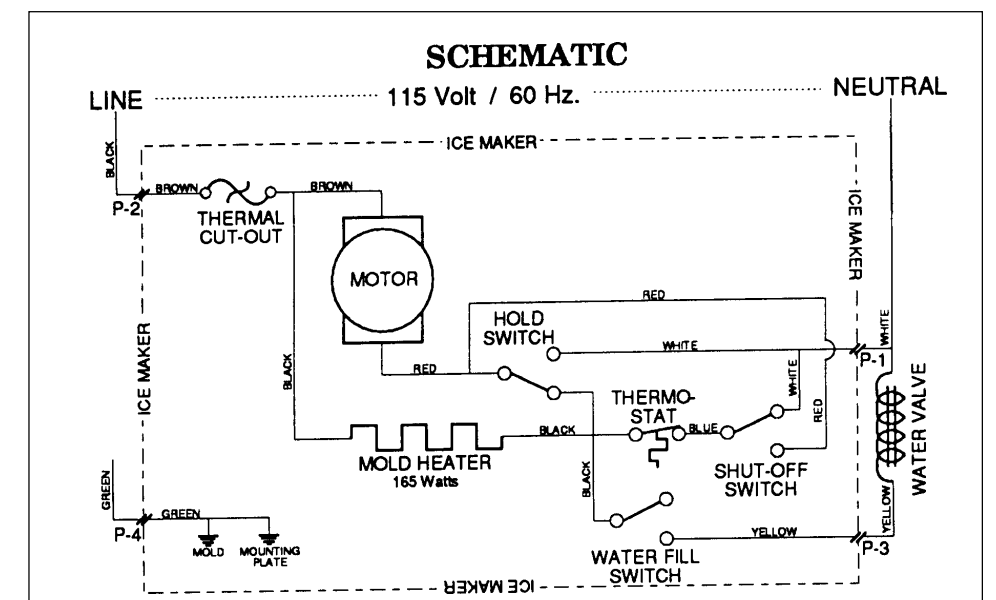
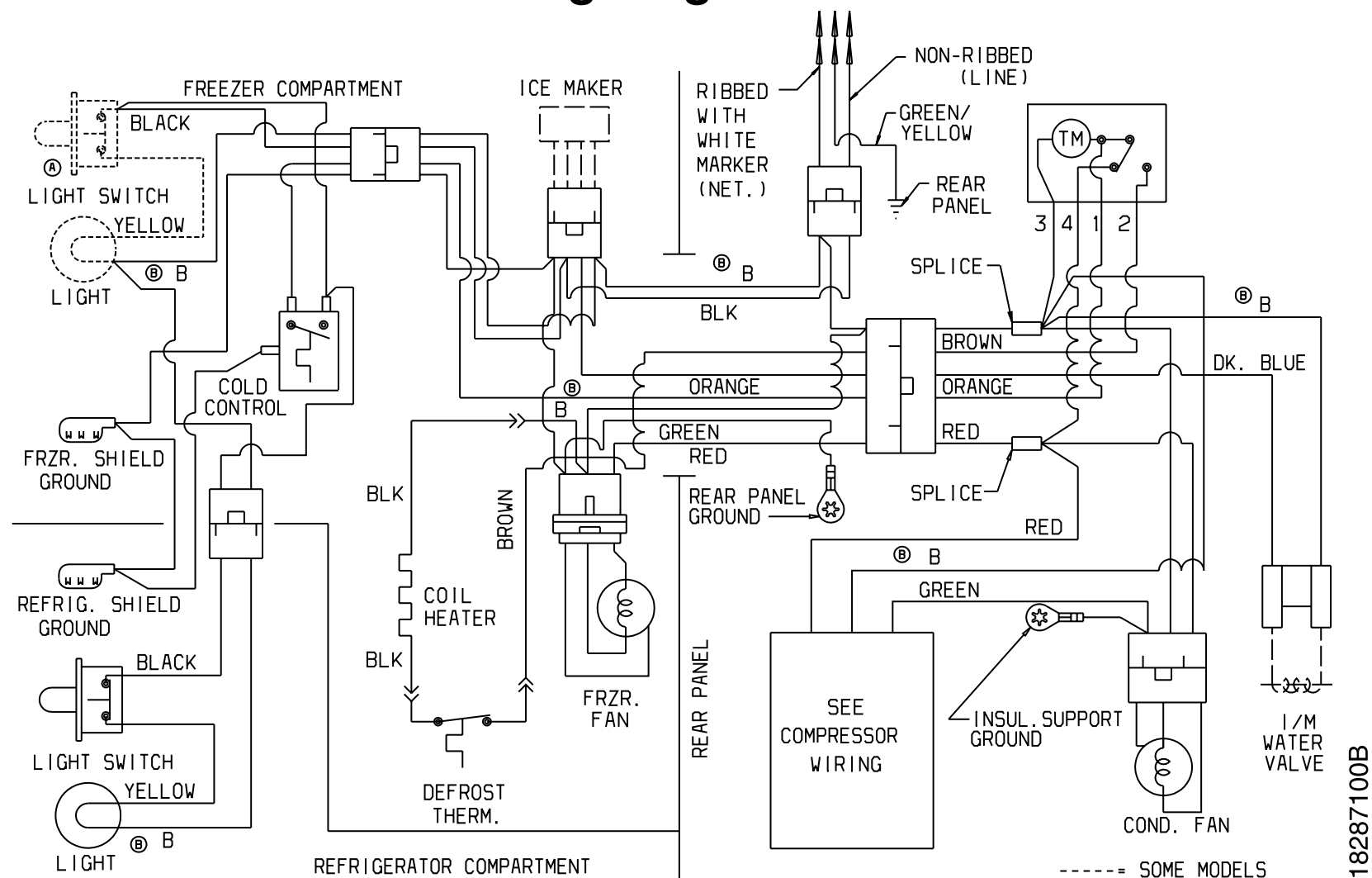

Figure 1



Wiring Diagram



NOTE: \textcircled{B} = WHITE

Schematic

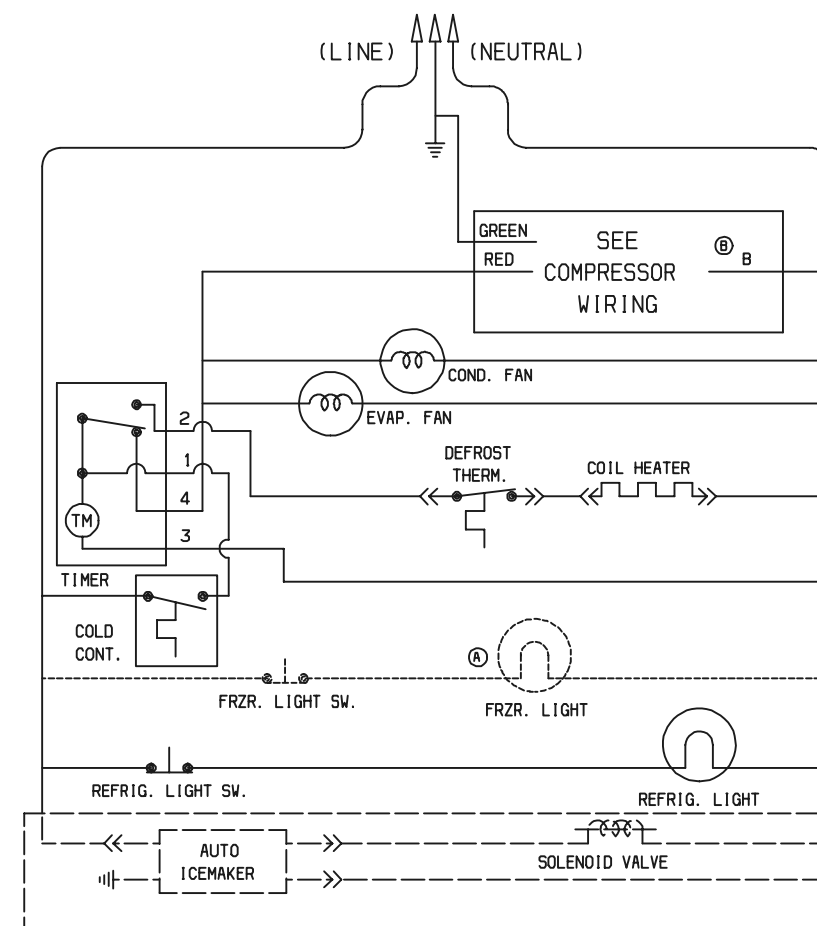

Compressor Wiring

P.T.C. STARTER WITH RUN CAPACITOR

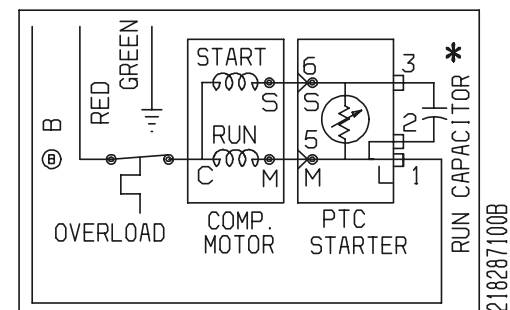

* CAPACITOR IS ONLY USED WITH SOME P.T.C. MODELS.

Compressor Terminal Location

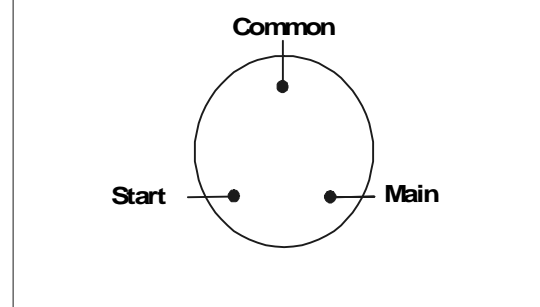

SERVICE DATA SHEET

218905000

ICE & WATER - AUTOMATIC DEFROST

SIDE BY SIDE MODELS

PERFORMANCE DATA NO LOAD AND NO DOOR OPENINGS AT MID-POINT CONTROL SETTING				
Type A With Run/Start Capacitor	65°F Ambient	90°F Ambient		
Operating Time	37 to 45%	60 to 68%		
Freezer Temperature	0° to 4°F	-2° to 3°F		
Refrigerator Temperature	34° to 39°F	34° to 39°F		
Low Side Pressure (cut-in)	5 to 12 psig	5 to 12 psig		
Low Side Pressure (cut-out)	-2 to 2 psig	-2 to 2 psig		
High Side Pressure (Last 1/3 of cycle)	110 to 130 psig	150 to 180 psig		
Wattage (Last 1/3 of cycle)	170 to 200	180 to 210		
Amps (Running)	1.5 to 1.8	1.5 to 1.8		
Base Voltage	115 VAC	115 VAC		
DEFROST SPECIFICATIONS				
Cabinet Size	Thermostat		Heater	
	Cut-in	Cut-out	Watts	Ohms
22' to 28'	+25°F	+47°F	600	22
Defrost 30 Minutes Every 8 Hours of Compressor Run Time				
CONDENSER FAN MOTOR				
Watts	RPM	Amps		
2.3	1300 CW Opposite Shaft	.15 Running		
THERMOSTATIC DAMPER				
Full Open		Closed		
33°F +/- 2°F		22°F +/- 2°F		
ICE MAKER SPECIFICATIONS				
Electrical	115 Volts	60 Hertz		
Thermostat	Opens at 48°F	Closes at 15°F		
Heater Wattage	165			

IMPORTANT SAFETY NOTICE

The information provided herein is designed to assist qualified repair personnel only. Untrained persons should not attempt to make repairs due to the possibility of electrical shock. Disconnect power cord before servicing.

IMPORTANT

If any green grounding wires are moved during servicing, they must be returned to their original position and properly secured.

CAUTION: System parts must be removed from cabinet before brazing. All electrical parts and wiring must be shielded from torch flame. Do not allow torch to contact insulation; it will char at 200°F and flash ignite (burn) at 500°F. Excessive heat will distort the plastic liner.

ICE MAKER INFORMATION

Test Cycling

Remove cover by inserting screwdriver in notch at bottom and prying cover from housing. Use screwdriver to rotate motor gear counter-clockwise until holding switch circuit is completed. (See Figure 1.) All components of ice maker should function to complete the cycle.

Water Fill Volume

The water fill adjustment screw will change the fill time. (See Figure 1.) One full turn is equal to 20cc (.68 oz.). The correct fill is 90 to 120cc (3.0 to 4.0 oz.). When a water valve is replaced, the fill volume must be checked.

ATTENTION SERVICERS

Get a HELPING HAND by visiting the Electrolux Home Product Web Site where you can access Service Bulletins, New and Old Product Repair Tips, Service Kits, an interactive Service Request Form, and FAQ's. Visit the site at:

<http://www.frigidaire.com/tip>

User Name: service

Password: tip

And now available at <http://www.frigidaire.com> are the following:

- Wiring Diagrams
- Owner's Guides
- Installation Instructions
- Parts Catalogs

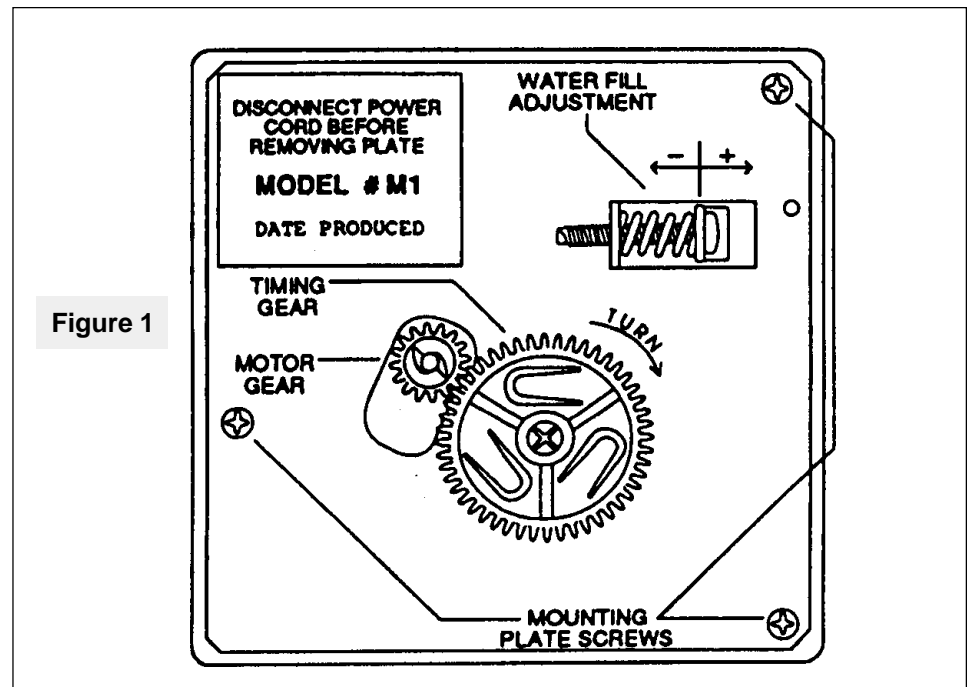
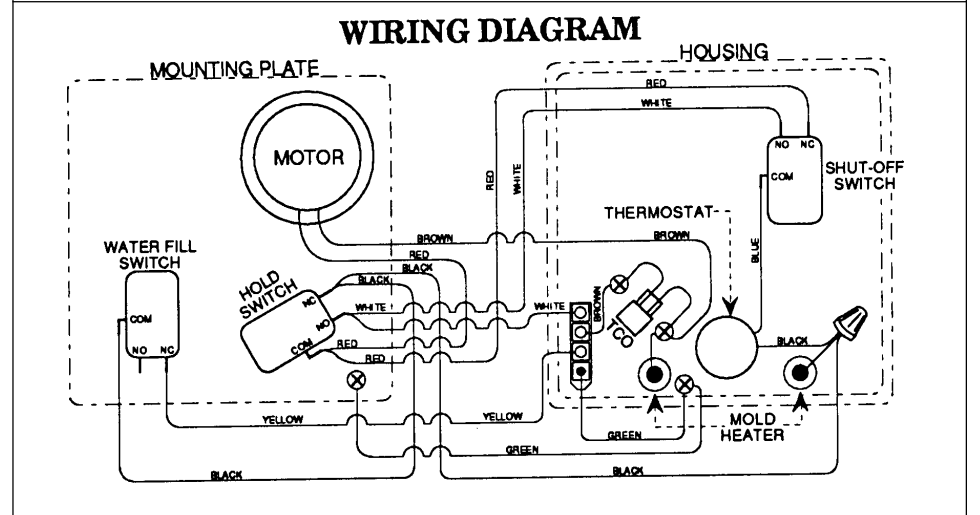
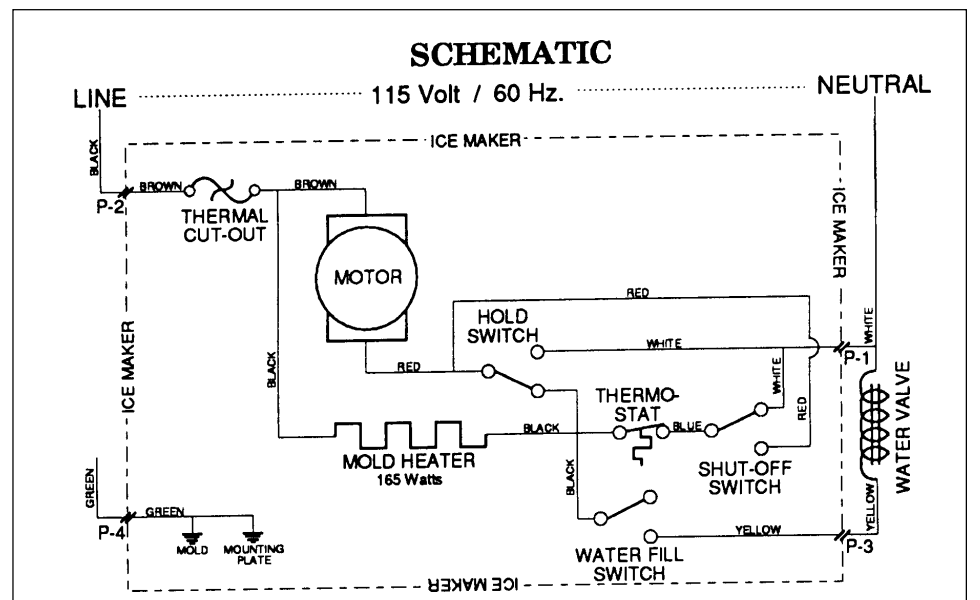
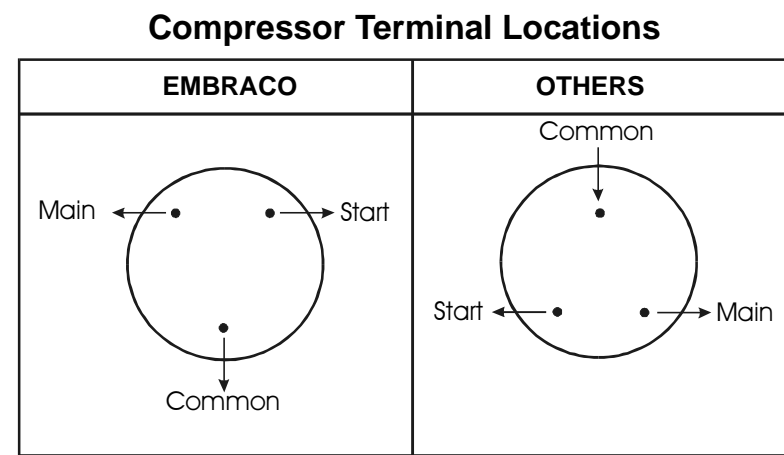
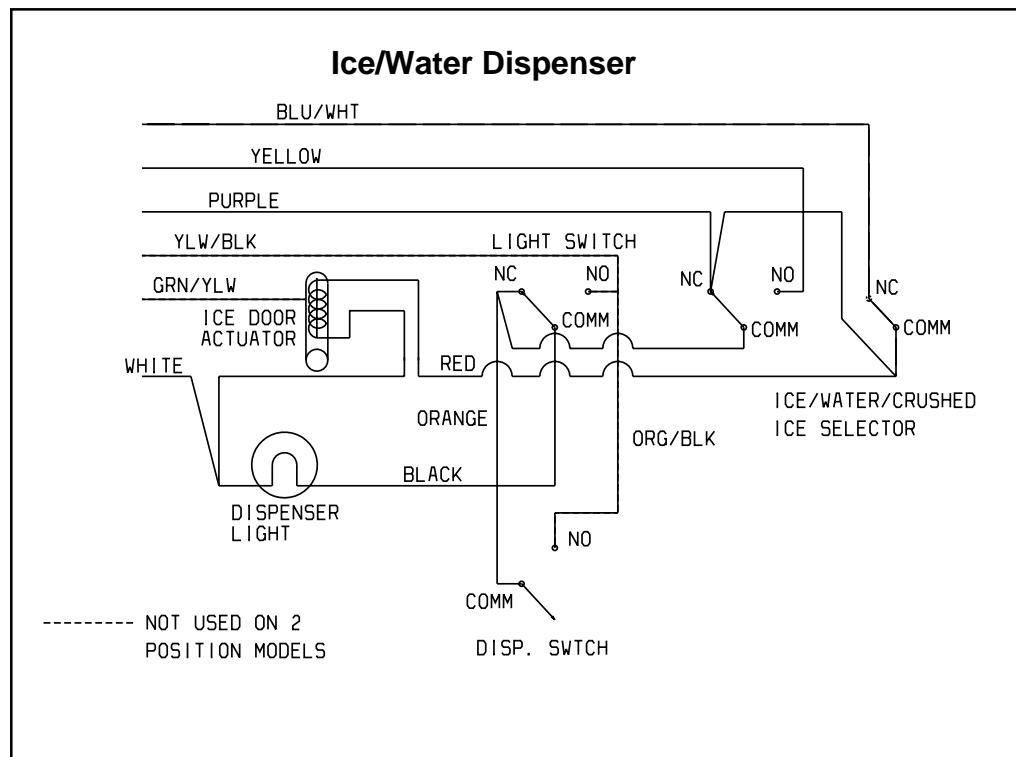
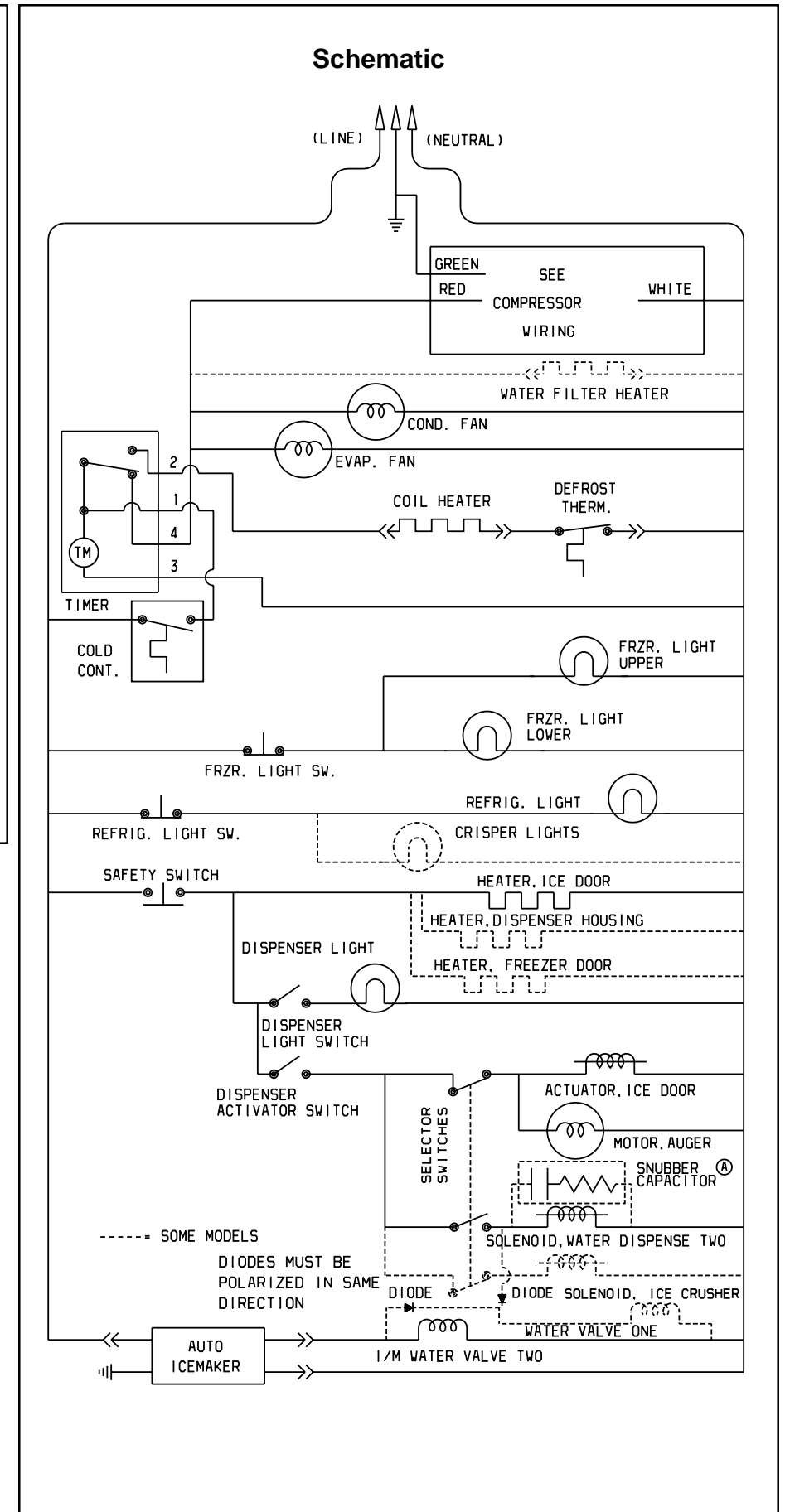
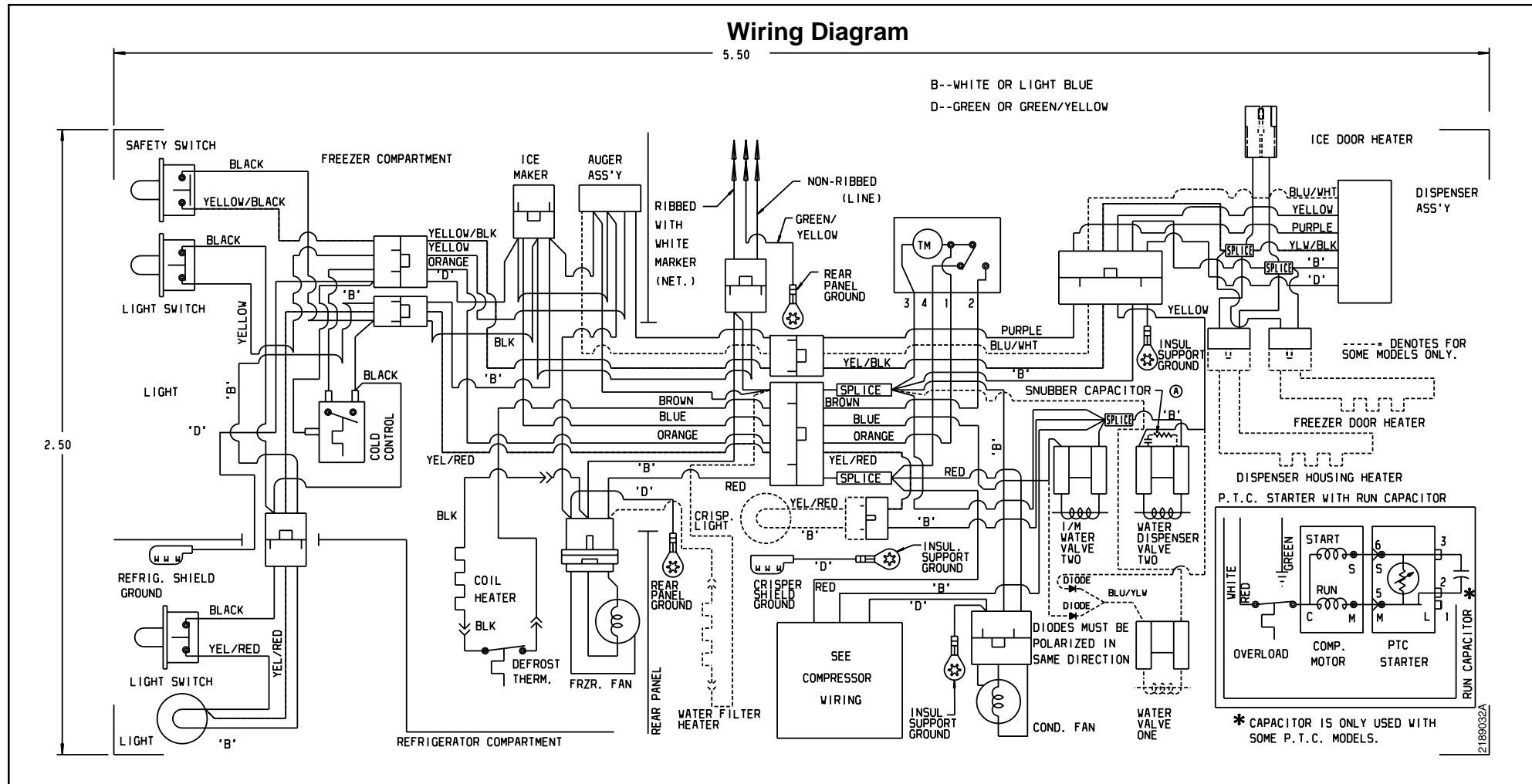

Figure 1





SERVICE DATA SHEET

218905001

ICE & WATER - AUTOMATIC DEFROST

SIDE BY SIDE MODELS

PERFORMANCE DATA NO LOAD AND NO DOOR OPENINGS AT MID-POINT CONTROL SETTING				
Type A With Run/Start Capacitor	65°F Ambient	90°F Ambient		
Operating Time	37 to 45%	60 to 68%		
Freezer Temperature	0° to 4°F	-2° to 3°F		
Refrigerator Temperature	34° to 39°F	34° to 39°F		
Low Side Pressure (cut-in)	5 to 12 psig	5 to 12 psig		
Low Side Pressure (cut-out)	-2 to 2 psig	-2 to 2 psig		
High Side Pressure (Last 1/3 of cycle)	110 to 130 psig	150 to 180 psig		
Wattage (Last 1/3 of cycle)	170 to 200	180 to 210		
Amps (Running)	1.5 to 1.8	1.5 to 1.8		
Base Voltage	115 VAC	115 VAC		
DEFROST SPECIFICATIONS				
Cabinet Size	Thermostat		Heater	
	Cut-in	Cut-out	Watts	Ohms
22' to 28'	+25°F	+47°F	450	30
Defrost 30 Minutes Every 8 Hours of Compressor Run Time				
CONDENSER FAN MOTOR				
Watts	RPM	Amps		
2.3	1300 CW Opposite Shaft	.15 Running		
THERMOSTATIC DAMPER				
Full Open		Closed		
33°F +/- 2°F		22°F +/- 2°F		
ICE MAKER SPECIFICATIONS				
Electrical	115 Volts	60 Hertz		
Thermostat	Opens at 48°F		Closes at 15°F	
Heater Wattage	165			

IMPORTANT SAFETY NOTICE

The information provided herein is designed to assist qualified repair personnel only. Untrained persons should not attempt to make repairs due to the possibility of electrical shock. Disconnect power cord before servicing.

IMPORTANT

If any green grounding wires are moved during servicing, they must be returned to their original position and properly secured.

CAUTION: System parts must be removed from cabinet before brazing. All electrical parts and wiring must be shielded from torch flame. Do not allow torch to contact insulation; it will char at 200°F and flash ignite (burn) at 500°F. Excessive heat will distort the plastic liner.

ICE MAKER INFORMATION

Test Cycling

Remove cover by inserting screwdriver in notch at bottom and prying cover from housing. Use screwdriver to rotate motor gear counter-clockwise until holding switch circuit is completed. (See Figure 1.) All components of ice maker should function to complete the cycle.

Water Fill Volume

The water fill adjustment screw will change the fill time. (See Figure 1.) One full turn is equal to 20cc (.68 oz.). The correct fill is 90 to 120cc (3.0 to 4.0 oz.). When a water valve is replaced, the fill volume must be checked.

ATTENTION SERVICERS

Get a HELPING HAND by visiting the Electrolux Home Product Web Site where you can access Service Bulletins, New and Old Product Repair Tips, Service Kits, an interactive Service Request Form, and FAQ's. Visit the site at:

<http://www.frigidaire.com/tip>

User Name: service

Password: tip

And now available at <http://www.frigidaire.com> are the following:

- Wiring Diagrams
- Owner's Guides
- Installation Instructions
- Parts Catalogs

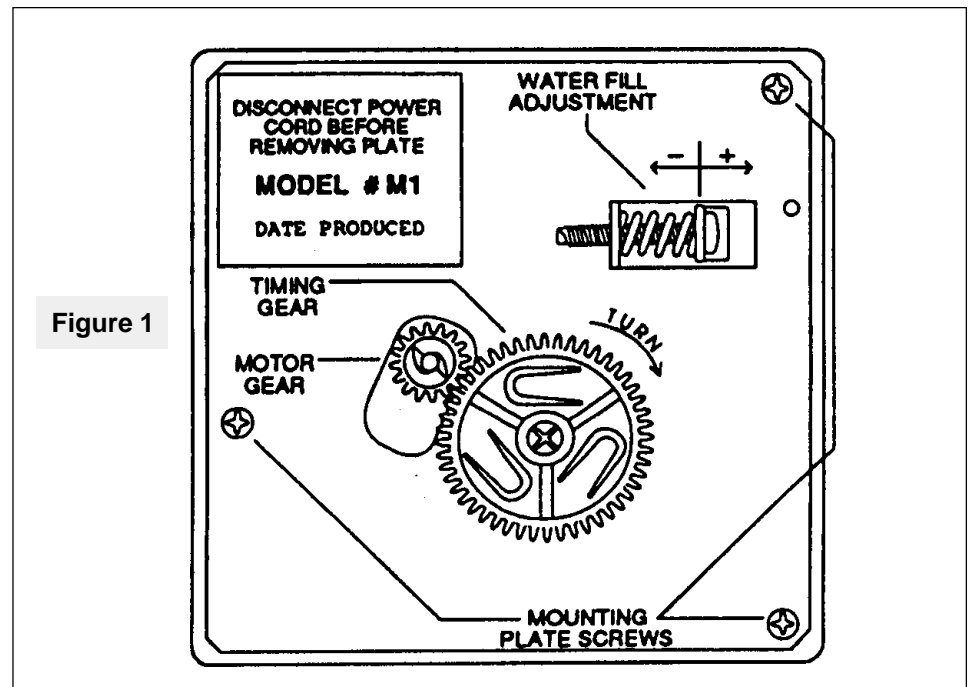
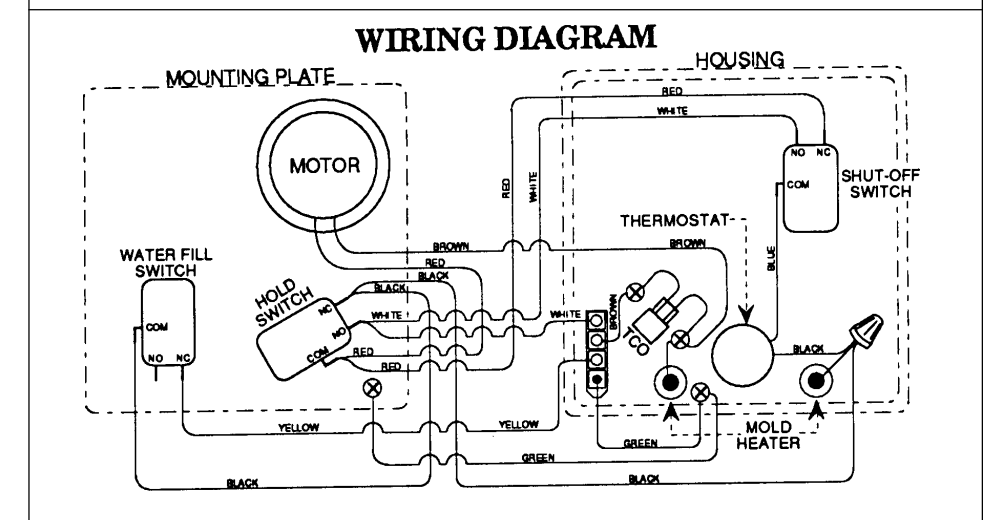
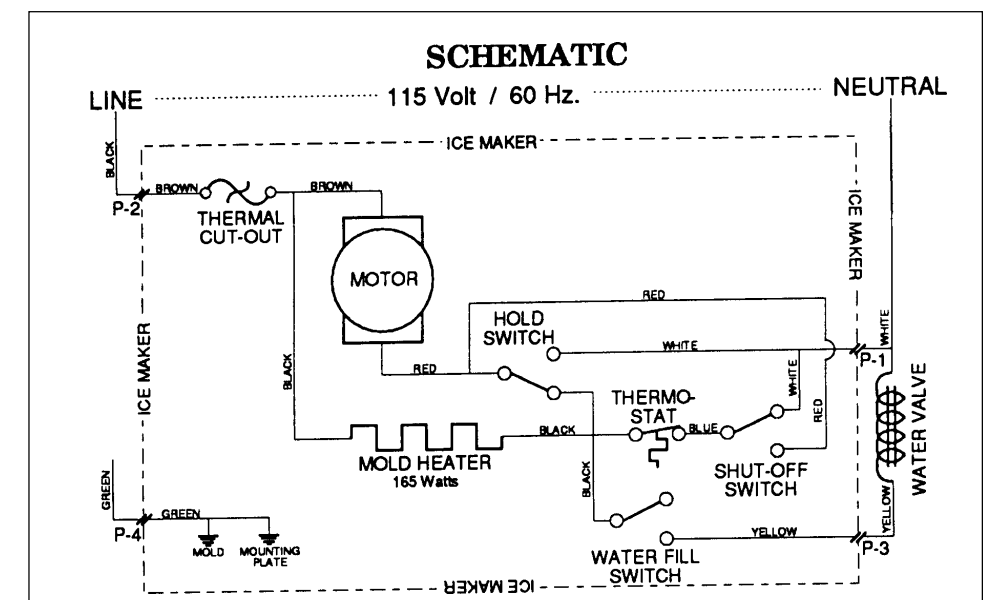
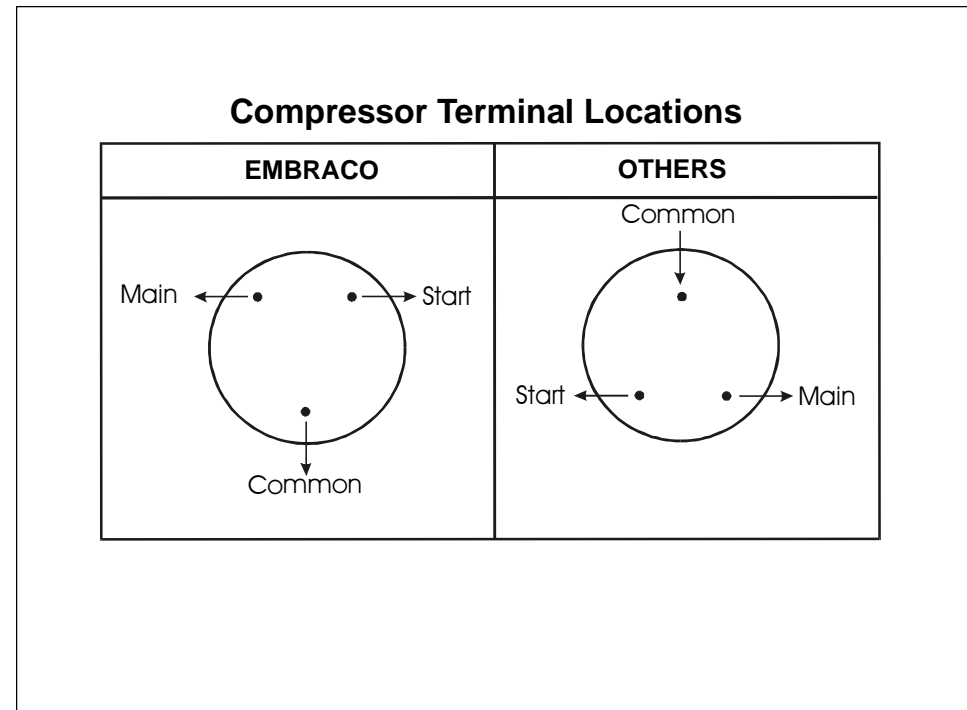
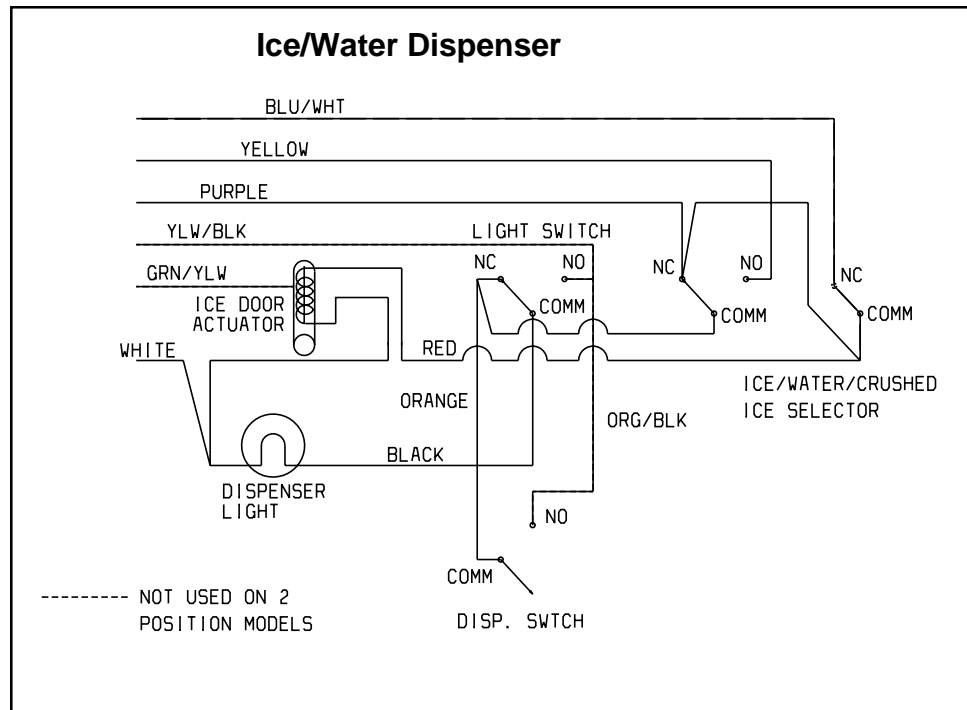
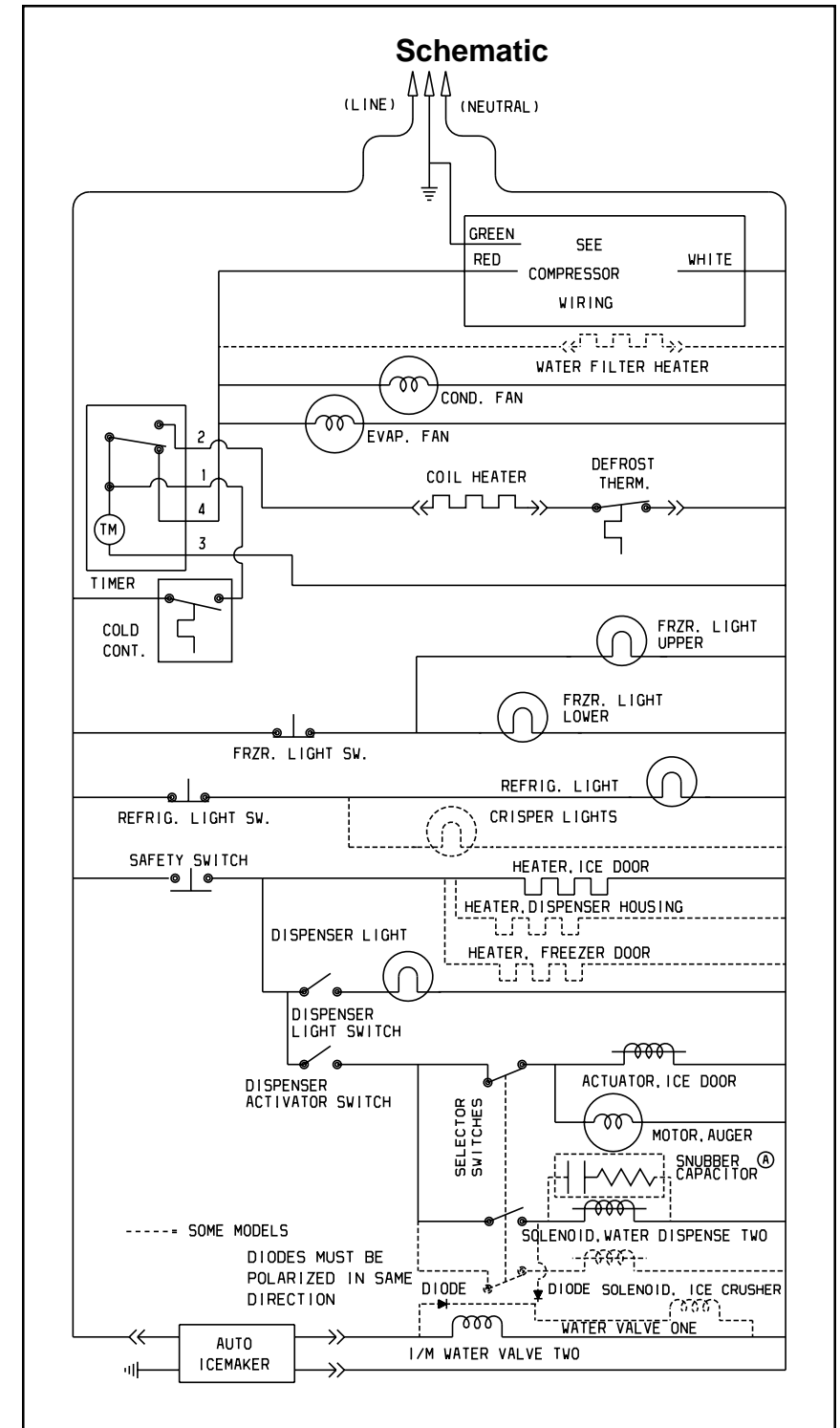
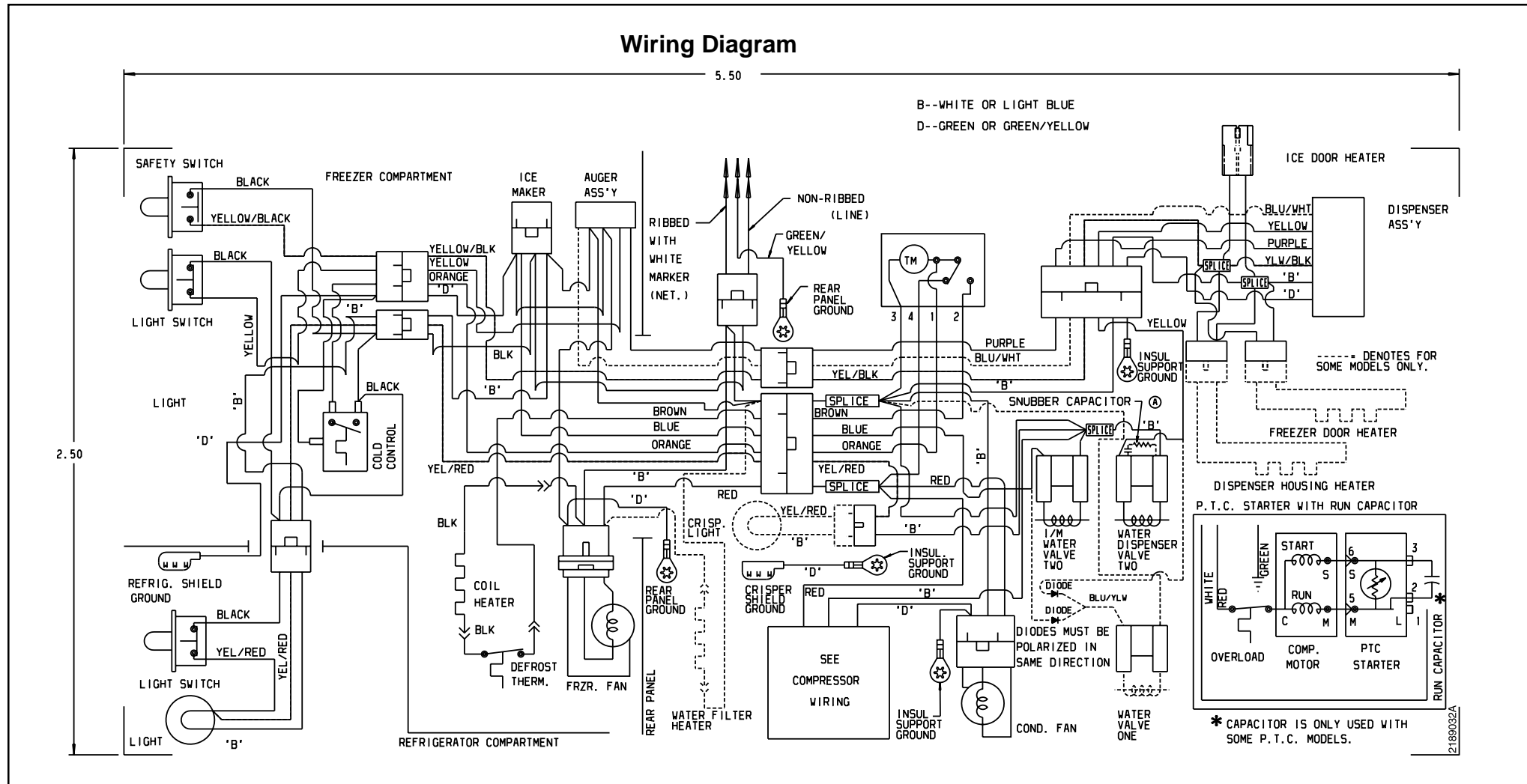

Figure 1





SERVICE DATA SHEET

218909400

STANDARD - AUTOMATIC DEFROST

SIDE BY SIDE MODELS

PERFORMANCE DATA NO LOAD AND NO DOOR OPENINGS AT MID-POINT CONTROL SETTING				
Type A With Run/Start Capacitor	65°F Ambient	90°F Ambient		
Operating Time	37 to 45%	60 to 68%		
Freezer Temperature	0° to 4°F	-2° to 3°F		
Refrigerator Temperature	34° to 39°F	34° to 39°F		
Low Side Pressure (cut-in)	5 to 12 psig	5 to 12 psig		
Low Side Pressure (cut-out)	-2 to 2 psig	-2 to 2 psig		
High Side Pressure (Last 1/3 of cycle)	110 to 130 psig	150 to 180 psig		
Wattage (Last 1/3 of cycle)	170 to 200	180 to 210		
Amps (Running)	1.5 to 1.8	1.5 to 1.8		
Base Voltage	115 VAC	115 VAC		
DEFROST SPECIFICATIONS				
Cabinet Size	Thermostat		Heater	
	Cut-in	Cut-out	Watts	Ohms
22' to 28'	+25°F	+47°F	600	22
Defrost 30 Minutes Every 8 Hours of Compressor Run Time				
CONDENSER FAN MOTOR				
Watts	RPM	Amps		
2.3	1300 CW Opposite Shaft	.15 Running		
THERMOSTATIC DAMPER				
	Full Open	Closed		
	33°F +/- 2°F	22°F +/- 2°F		
ICE MAKER SPECIFICATIONS				
Electrical	115 Volts	60 Hertz		
Thermostat	Opens at 48°F	Closes at 15°F		
Heater Wattage	165			

IMPORTANT SAFETY NOTICE

The information provided herein is designed to assist qualified repair personnel only. Untrained persons should not attempt to make repairs due to the possibility of electrical shock. Disconnect power cord before servicing.

IMPORTANT

If any green grounding wires are moved during servicing, they must be returned to their original position and properly secured.

CAUTION: System parts must be removed from cabinet before brazing. All electrical parts and wiring must be shielded from torch flame. Do not allow torch to contact insulation; it will char at 200°F and flash ignite (burn) at 500°F. Excessive heat will distort the plastic liner.

ICE MAKER INFORMATION

Test Cycling

Remove cover by inserting screwdriver in notch at bottom and prying cover from housing. Use screwdriver to rotate motor gear counter-clockwise until holding switch circuit is completed. (See Figure 1.) All components of ice maker should function to complete the cycle.

Water Fill Volume

The water fill adjustment screw will change the fill time. (See Figure 1.) One full turn is equal to 20cc (.68 oz.). The correct fill is 90 to 120cc (3.0 to 4.0 oz.). When a water valve is replaced, the fill volume must be checked.

ATTENTION SERVICERS

Get a HELPING HAND by visiting the Electrolux Home Product Web Site where you can access Service Bulletins, New and Old Product Repair Tips, Service Kits, an interactive Service Request Form, and FAQ's. Visit the site at:

<http://www.frigidaire.com/tip>

User Name: service

Password: tip

And now available at <http://www.frigidaire.com> are the following:

- Wiring Diagrams
- Owner's Guides
- Installation Instructions
- Parts Catalogs

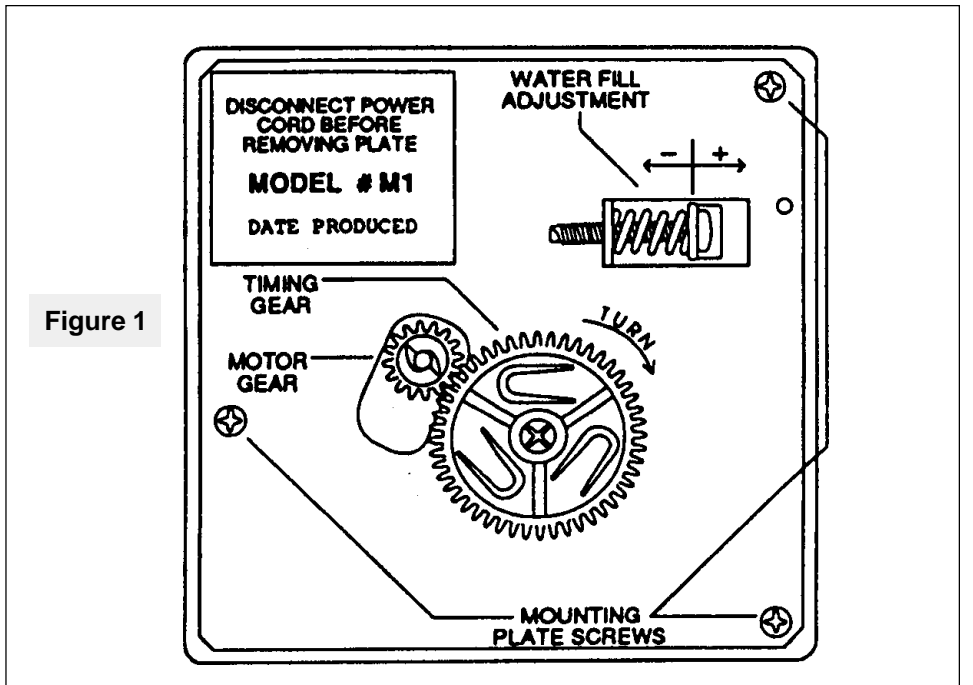
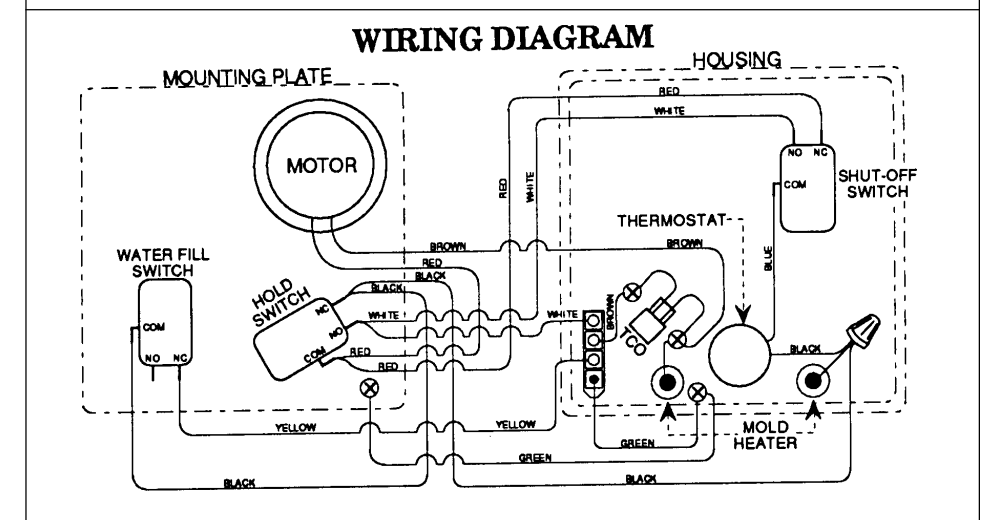
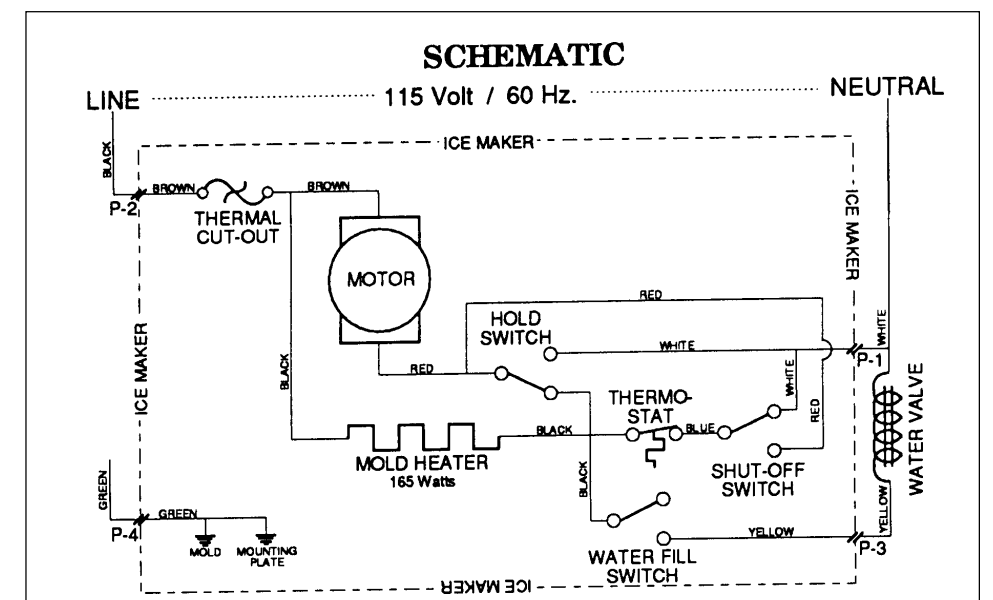
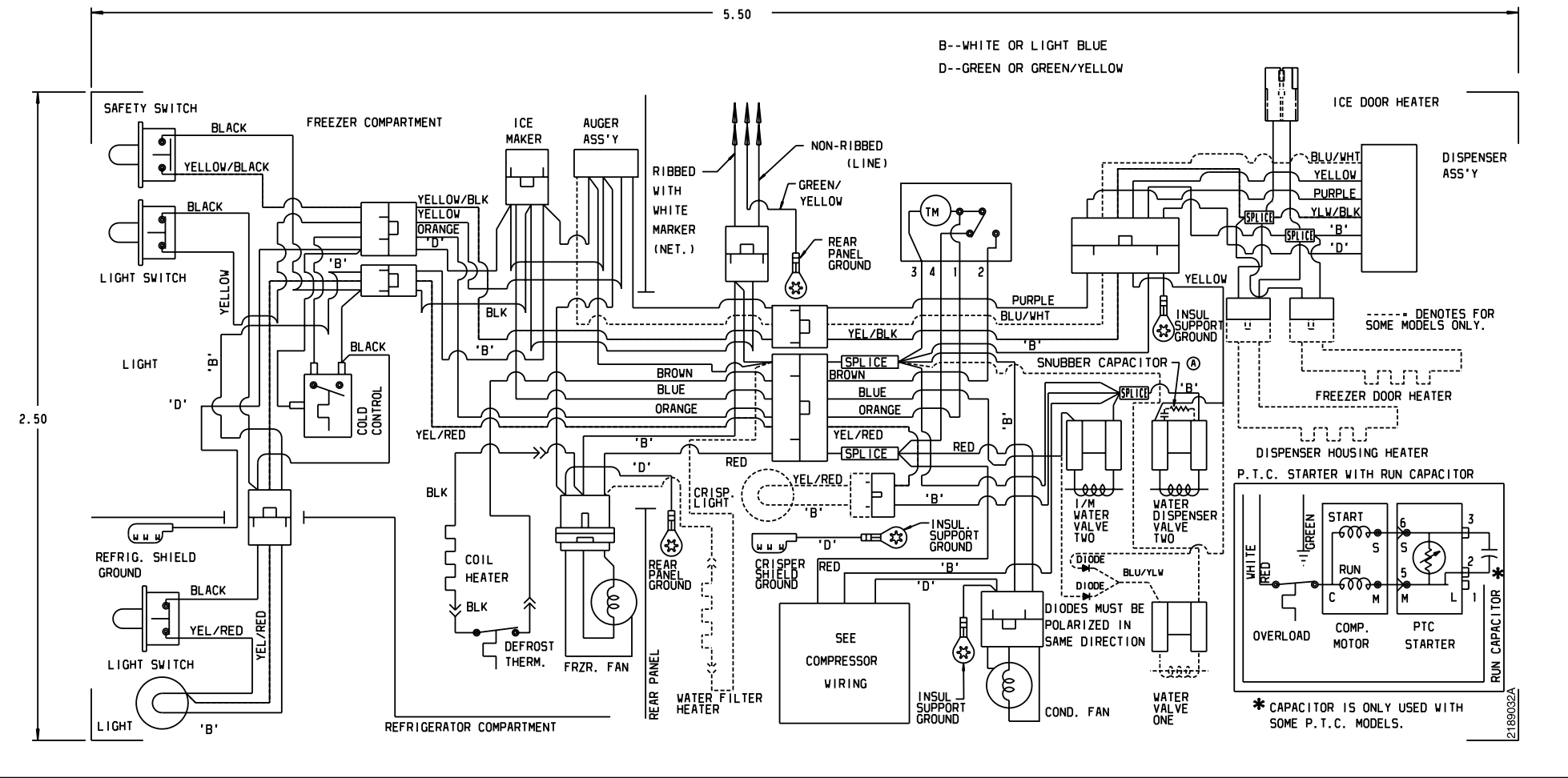

Figure 1



WIRING DIAGRAM



LADDER DIAGRAM

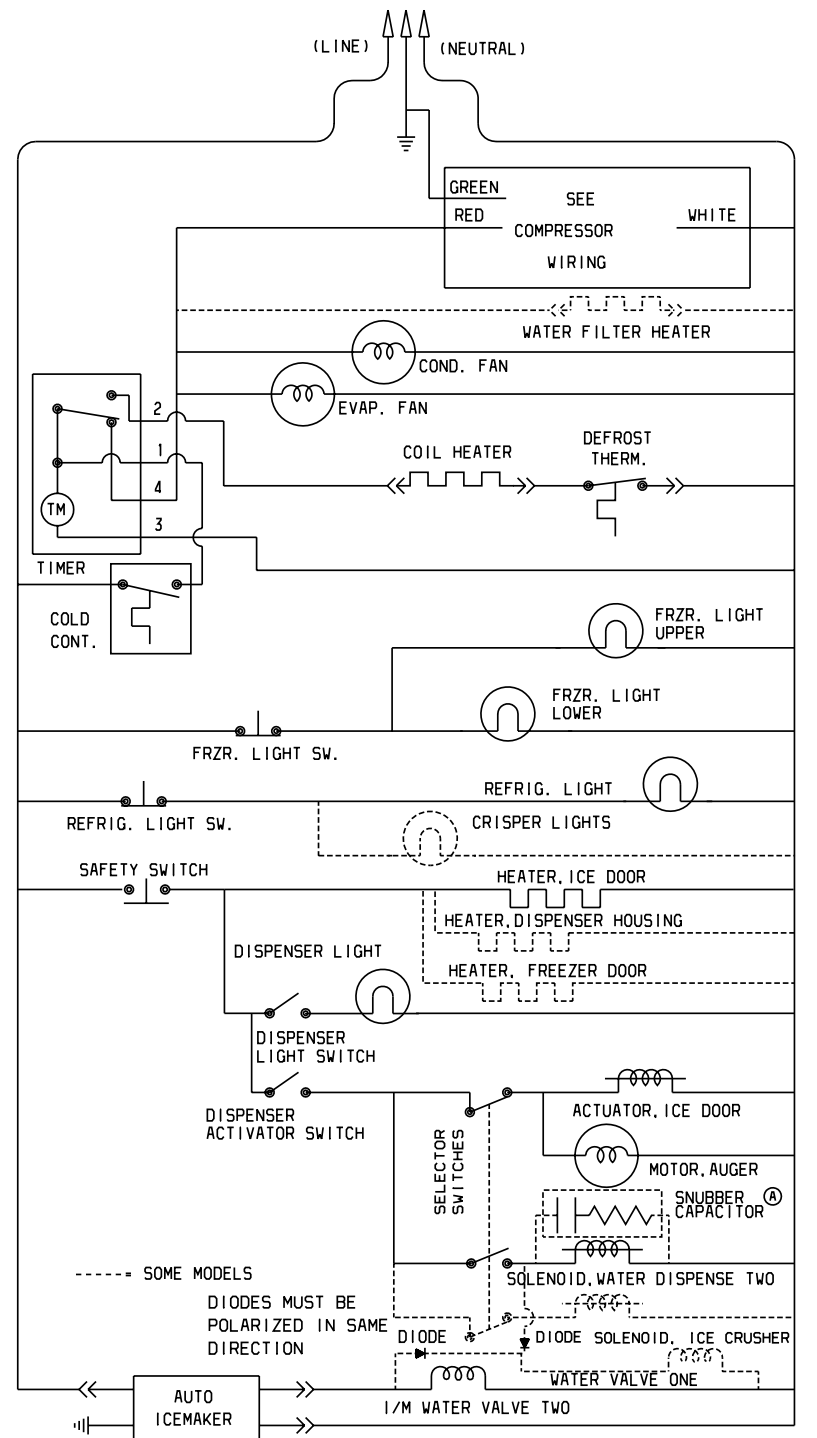

ICE/WATER DISPENSER

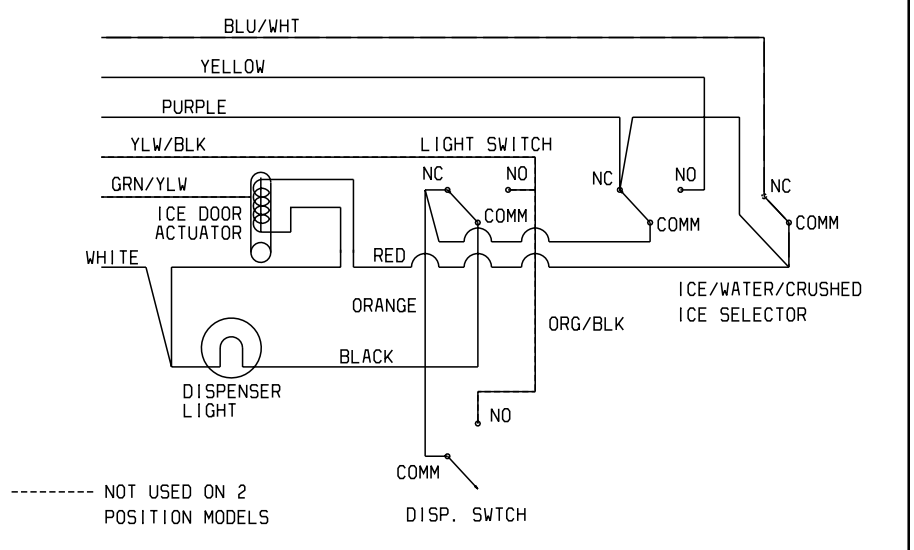

SERVICE DATA SHEET

218909401

STANDARD - AUTOMATIC DEFROST

SIDE BY SIDE MODELS

PERFORMANCE DATA NO LOAD AND NO DOOR OPENINGS AT MID-POINT CONTROL SETTING				
Type A With Run/Start Capacitor	65°F Ambient	90°F Ambient		
Operating Time	37 to 45%	60 to 68%		
Freezer Temperature	0° to 4°F	-2° to 3°F		
Refrigerator Temperature	34° to 39°F	34° to 39°F		
Low Side Pressure (cut-in)	5 to 12 psig	5 to 12 psig		
Low Side Pressure (cut-out)	-2 to 2 psig	-2 to 2 psig		
High Side Pressure (Last 1/3 of cycle)	110 to 130 psig	150 to 180 psig		
Wattage (Last 1/3 of cycle)	170 to 200	180 to 210		
Amps (Running)	1.5 to 1.8	1.5 to 1.8		
Base Voltage	115 VAC	115 VAC		
DEFROST SPECIFICATIONS				
Cabinet Size	Thermostat		Heater	
	Cut-in	Cut-out	Watts	Ohms
22' to 28'	+25°F	+47°F	450	30
Defrost 30 Minutes Every 8 Hours of Compressor Run Time				
CONDENSER FAN MOTOR				
Watts	RPM	Amps		
2.3	1300 CW Opposite Shaft	.15 Running		
THERMOSTATIC DAMPER				
	Full Open	Closed		
	33°F +/- 2°F	22°F +/- 2°F		
ICE MAKER SPECIFICATIONS				
Electrical	115 Volts	60 Hertz		
Thermostat	Opens at 48°F	Closes at 15°F		
Heater Wattage	165			

IMPORTANT SAFETY NOTICE

The information provided herein is designed to assist qualified repair personnel only. Untrained persons should not attempt to make repairs due to the possibility of electrical shock. Disconnect power cord before servicing.

IMPORTANT

If any green grounding wires are moved during servicing, they must be returned to their original position and properly secured.

CAUTION: System parts must be removed from cabinet before brazing. All electrical parts and wiring must be shielded from torch flame. Do not allow torch to contact insulation; it will char at 200°F and flash ignite (burn) at 500°F. Excessive heat will distort the plastic liner.

ICE MAKER INFORMATION

Test Cycling

Remove cover by inserting screwdriver in notch at bottom and prying cover from housing. Use screwdriver to rotate motor gear counter-clockwise until holding switch circuit is completed. (See Figure 1.) All components of ice maker should function to complete the cycle.

Water Fill Volume

The water fill adjustment screw will change the fill time. (See Figure 1.) One full turn is equal to 20cc (.68 oz.). The correct fill is 90 to 120cc (3.0 to 4.0 oz.). When a water valve is replaced, the fill volume must be checked.

ATTENTION SERVICERS

Get a HELPING HAND by visiting the Electrolux Home Product Web Site where you can access Service Bulletins, New and Old Product Repair Tips, Service Kits, an interactive Service Request Form, and FAQ's. Visit the site at:

<http://www.frigidaire.com/tip>

User Name: service

Password: tip

And now available at <http://www.frigidaire.com> are the following:

- Wiring Diagrams
- Owner's Guides
- Installation Instructions
- Parts Catalogs

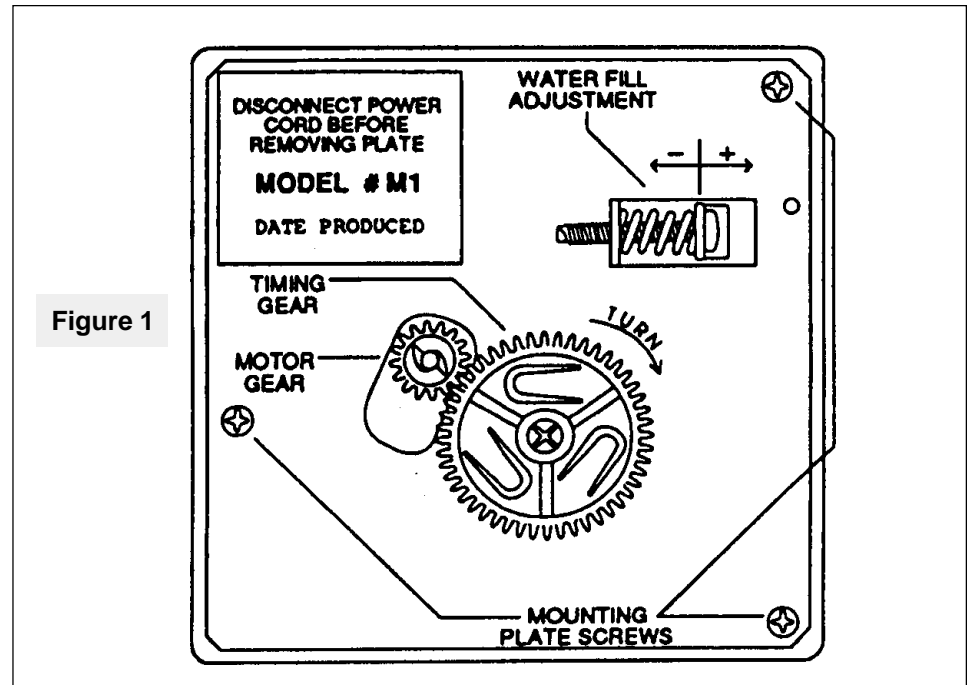
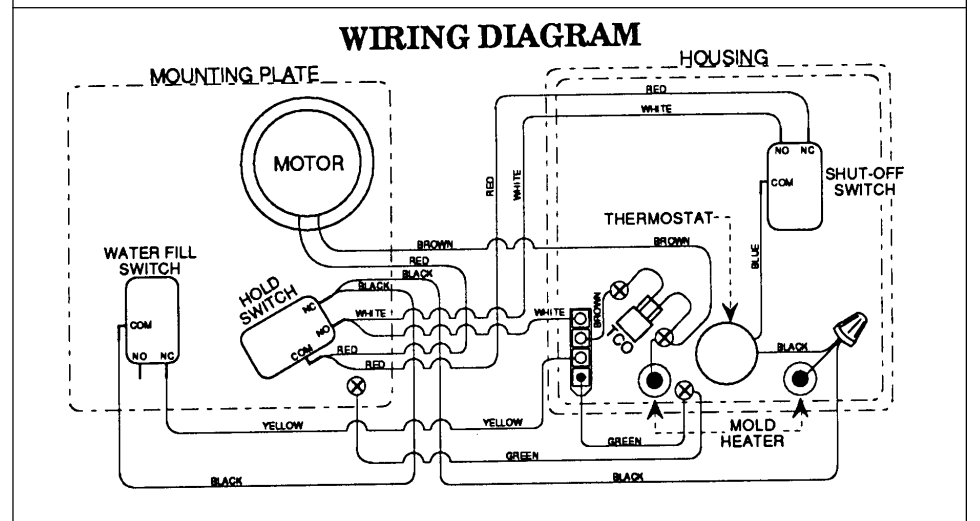
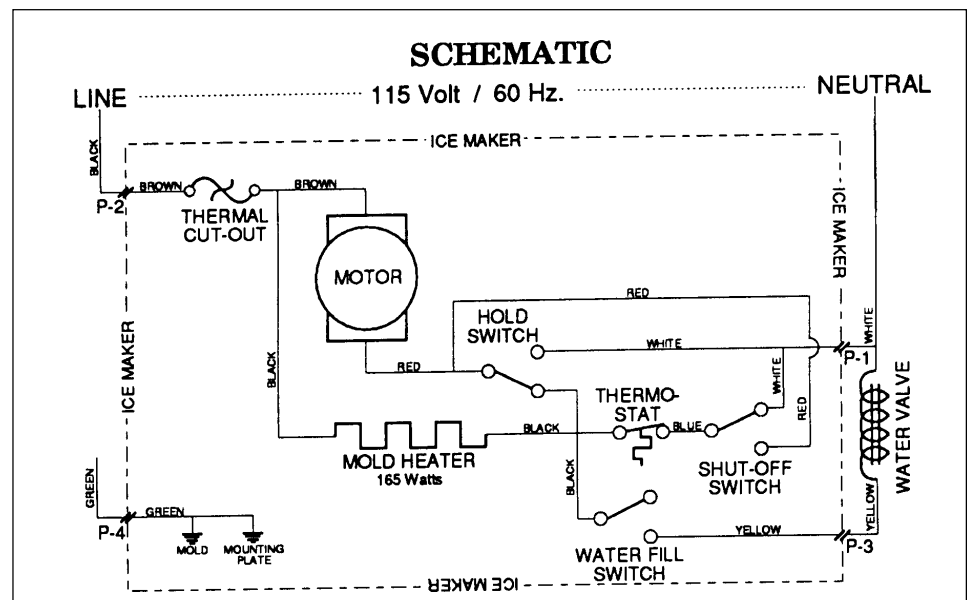
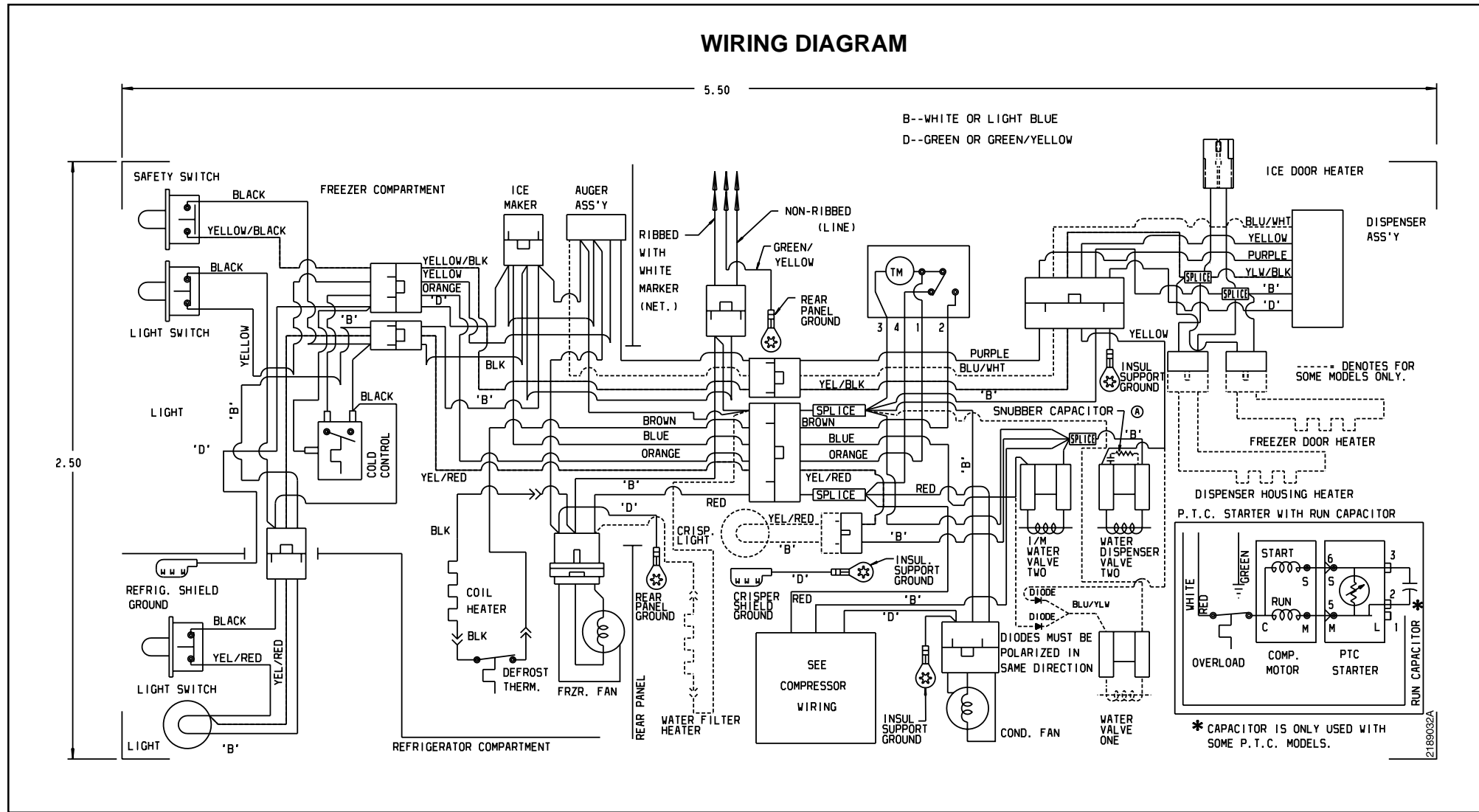

Figure 1



WIRING DIAGRAM



Schematic

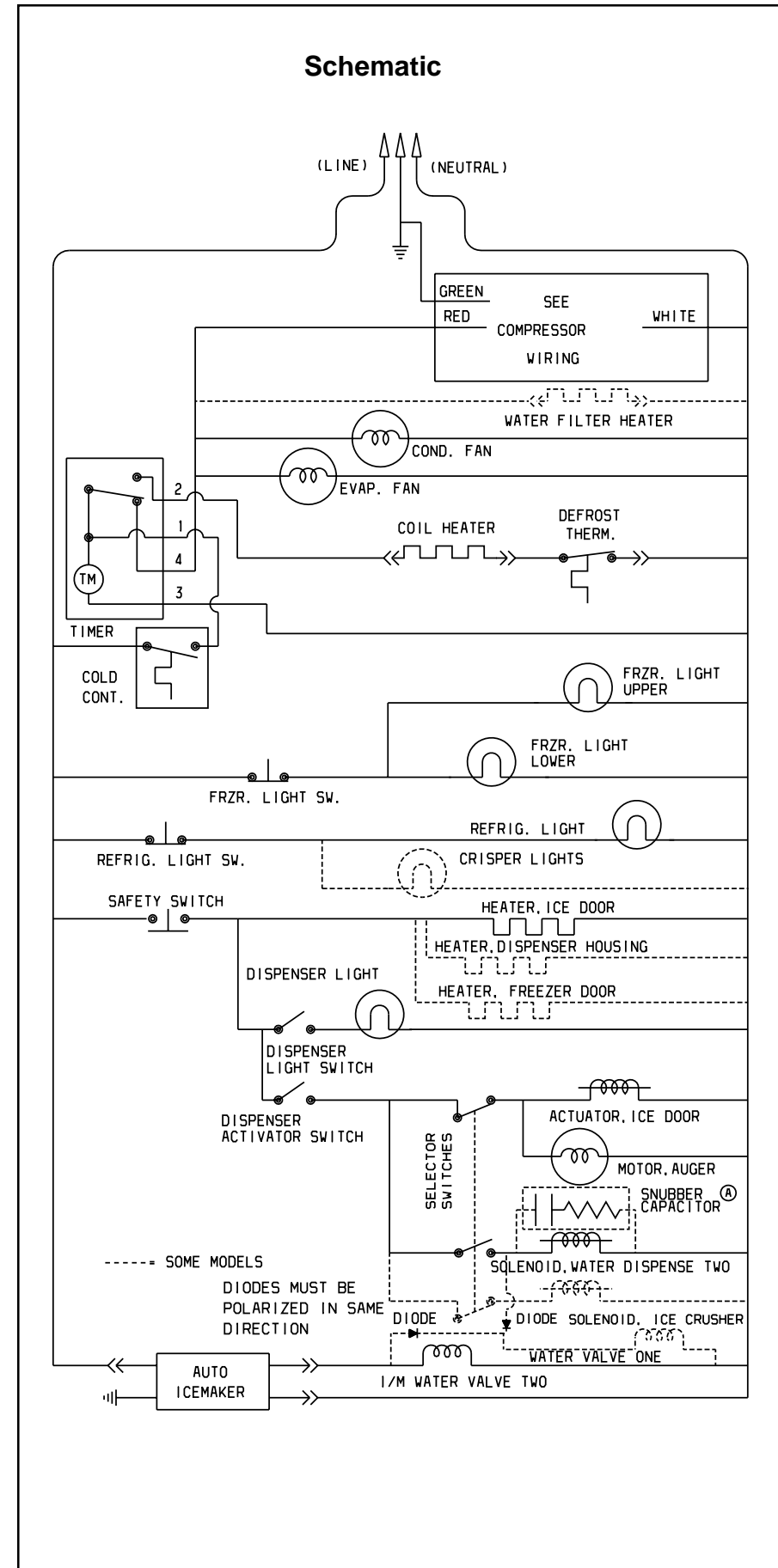

Ice/Water Dispenser

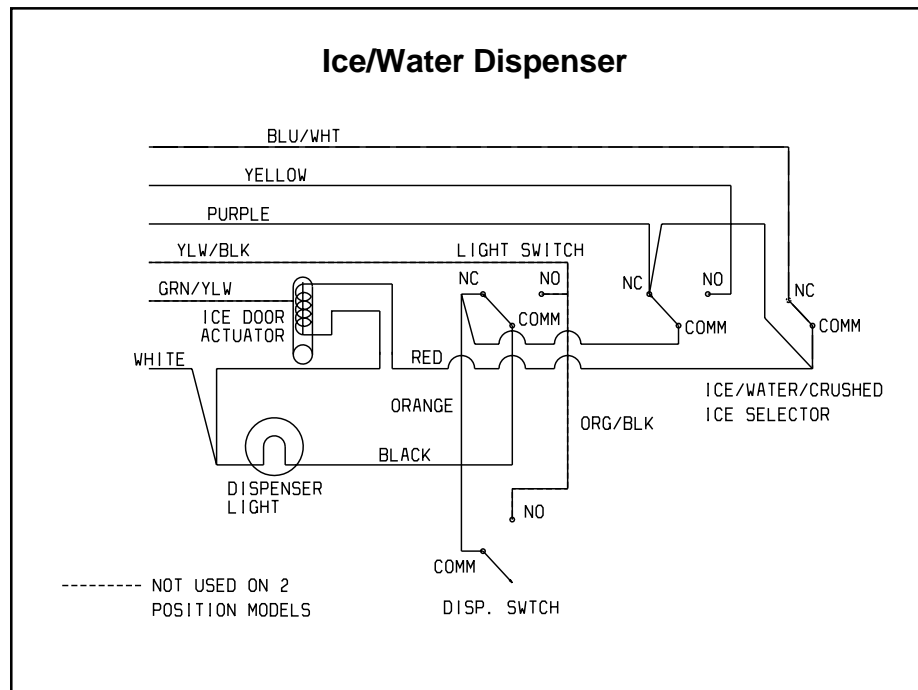

SERVICE DATA SHEET

240389600

ICE & WATER - AUTOMATIC DEFROST

SIDE BY SIDE MODELS

PERFORMANCE DATA NO LOAD AND NO DOOR OPENINGS AT MID-POINT CONTROL SETTING				
Type A With Run/Start Capacitor	65°F (18°C) Ambient	90°F (32°C) Ambient		
Operating Time	32 to 40%	55 to 65%		
Freezer Temperature	0° to 4°F -18° to -16°C	-1° to 3°F -18° to -16°C		
Refrigerator Temperature	34° to 39°F 1° to 4°C	34° to 39°F 1° to 4°C		
Low Side Pressure (cut-in)	5 to 12 psig 34 to 83 kPa	5 to 12 psig 34 to 83 kPa		
Low Side Pressure (cut-out)	-2 to 2 psig -14 to 14 kPa	-2 to 2 psig -14 to 14 kPa		
High Side Pressure (Last 1/3 of cycle)	90 to 115 psig 621 to 793 kPa	130 to 155 psig 896 to 1069 kPa		
Wattage (Last 1/3 of cycle)	120 to 150	130 to 160		
Amps (Running)	1.2 to 1.5	1.2 to 1.5		
Base Voltage	115 VAC	115 VAC		
DEFROST SPECIFICATIONS				
Cabinet Size	Thermostat		Heater	
	Cut-in	Cut-out	Watts	Ohms
23' & 26'	25°F -4°C	47°F 8°C	450	30
Defrost 30 Minutes Every 8 Hours of Compressor Run Time				
CONDENSER FAN MOTOR				
Watts	RPM	Amps		
7	1100 CW Opposite Shaft	.1 Running		
ICE MAKER SPECIFICATIONS				
Electrical	115 Volts	60 Hertz		
Thermostat	Opens at 48°F (9°C)	Closes at 15°F (-9°C)		
Heater Wattage	165			
ICE MAKER CONNECTOR PLUG CONNECTIONS				
Wire Number	Wire Color	Connects to:		
1	Green/Yellow	Ground		
2	Yellow	Water Valve		
3	Black	Line		
4	Lt. Blue	Neutral		

IMPORTANT SAFETY NOTICE

The information provided herein is designed to assist qualified repair personnel only. Untrained persons should not attempt to make repairs due to the possibility of electrical shock. Disconnect power cord before servicing.

IMPORTANT

If any green grounding wires are moved during servicing, they must be returned to their original position and properly secured.

CAUTION: All electrical parts and wiring must be shielded from torch flame. Do not allow torch to contact insulation; it will char at 200°F and flash ignite (burn) at 500°F. Excessive heat will distort the plastic liner.

ICE MAKER INFORMATION

Test Cycling

Remove cover by inserting screwdriver in notch at bottom and prying cover from housing. Use screwdriver to rotate motor gear counterclockwise until holding switch circuit is completed. (See Figure 1.) All components of ice maker should function to complete the cycle.

Water Fill Volume

The water fill adjustment screw will change the fill time. (See Figure 1.) One full turn is equal to 20cc (.68 oz.). The correct fill is 102 to 130cc (3.4 to 4.3 oz.). When a water valve is replaced, the fill volume must be checked.

ATTENTION SERVICERS

Get a HELPING HAND by visiting the Electrolux Home Product Web Site where you can access Service Bulletins, New and Old Product Repair Tips, Service Kits, an interactive Service Request Form, and FAQ's. Visit the site at:

<http://www.frigidaire.com/tip>

User Name: service

Password: tip

And now available at <http://www.frigidaire.com> are the following:

- Wiring Diagrams
- Owner's Guides
- Installation Instructions
- Parts Catalogs

Figure 1

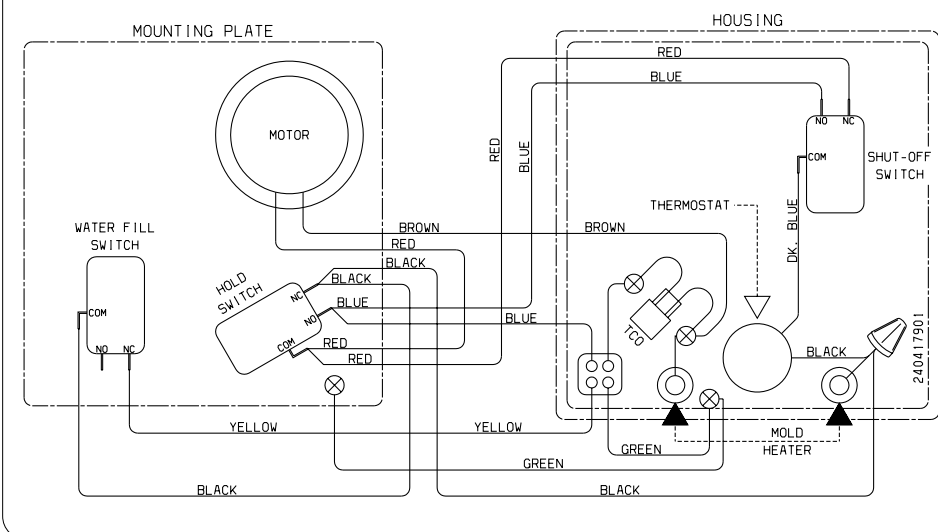
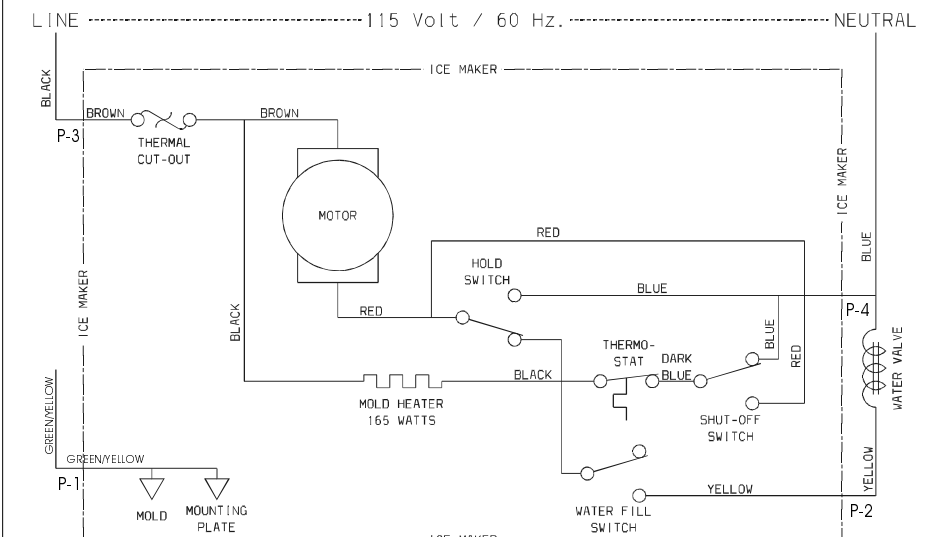
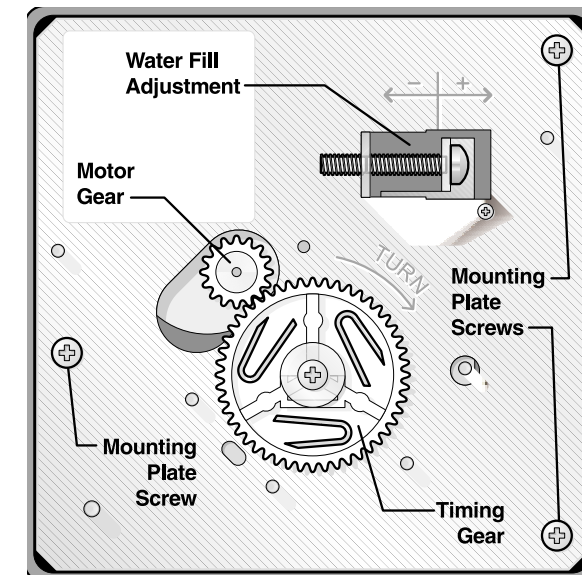

Pictorial Schematic

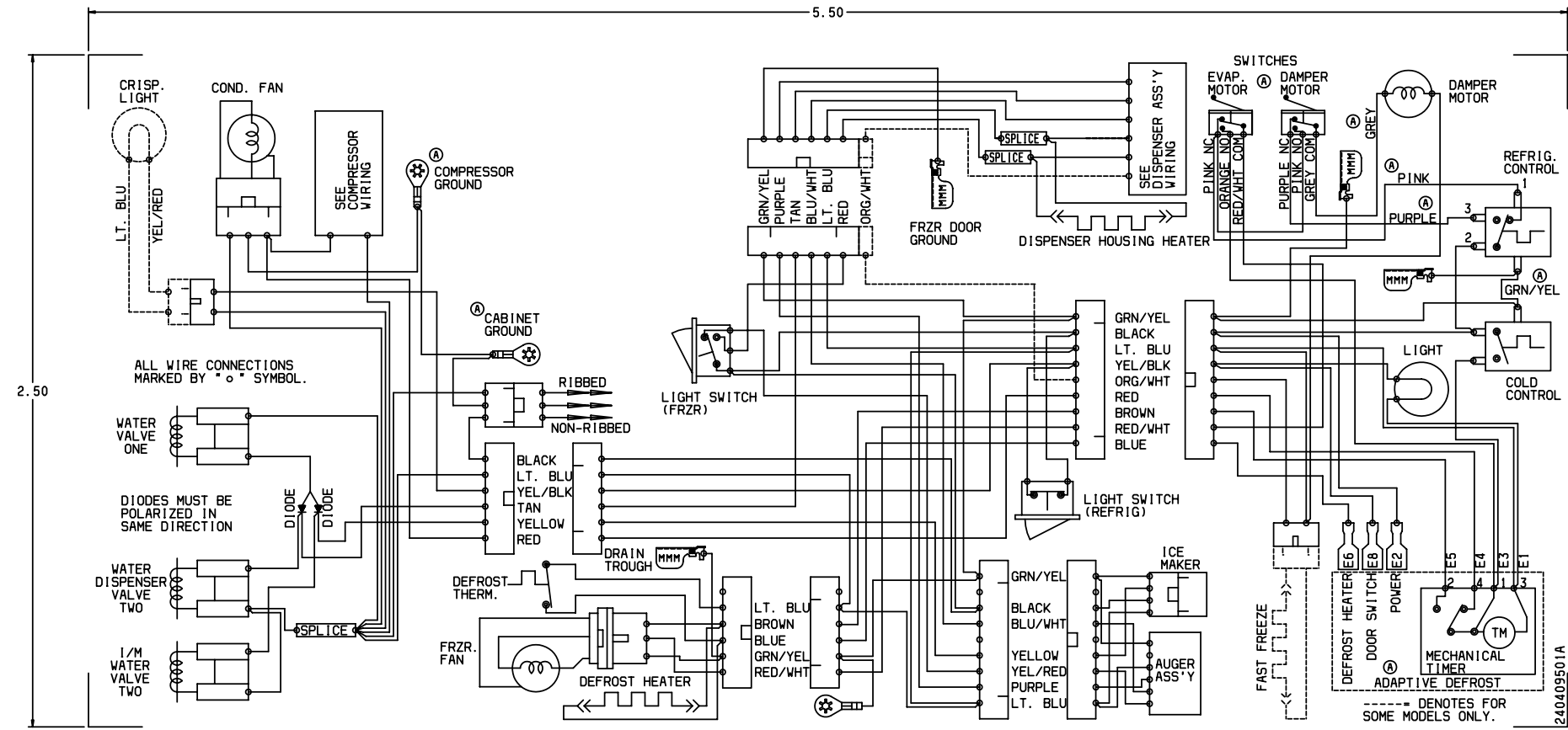

Ladder Schematic

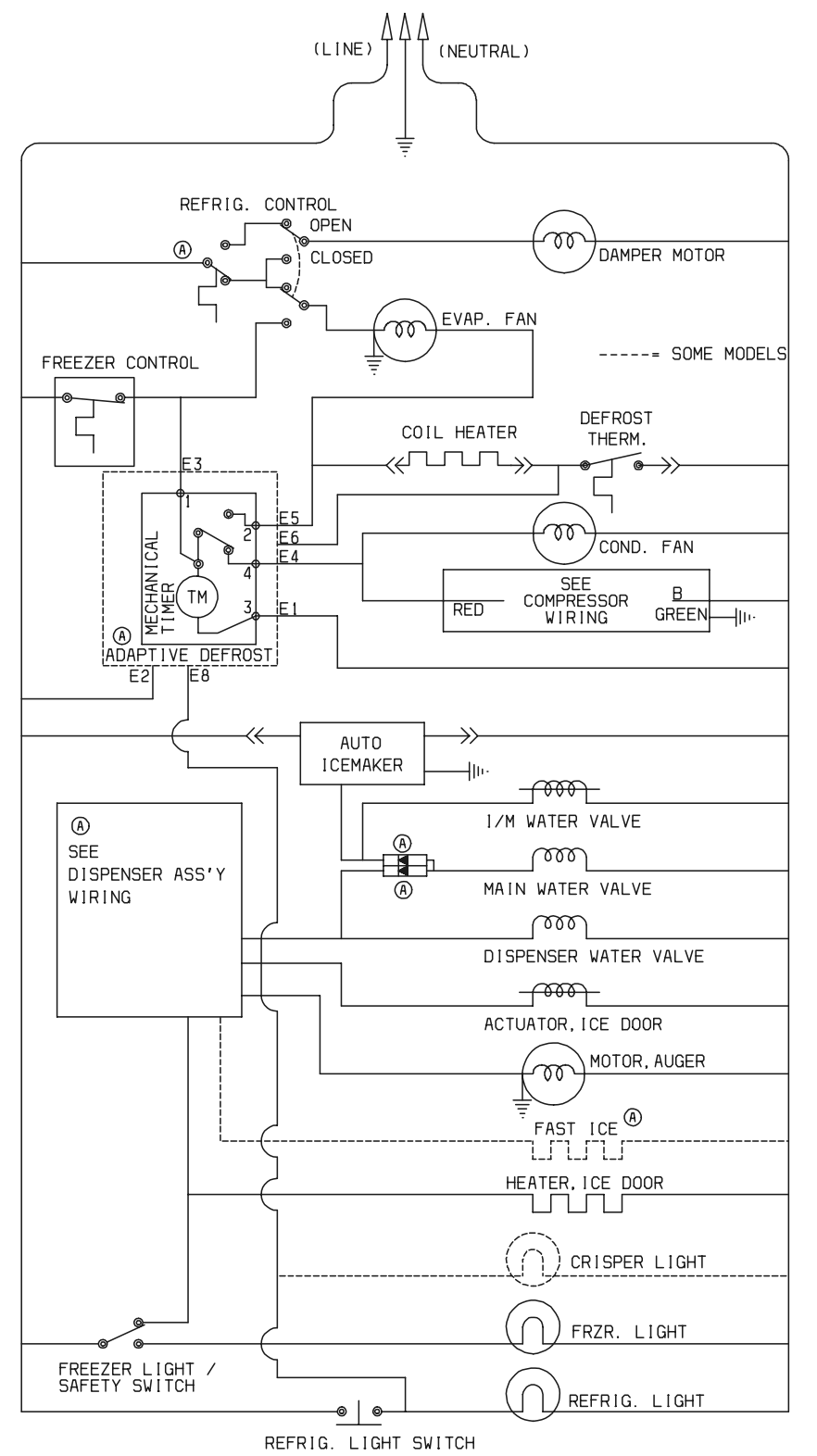

Electronic Dispenser

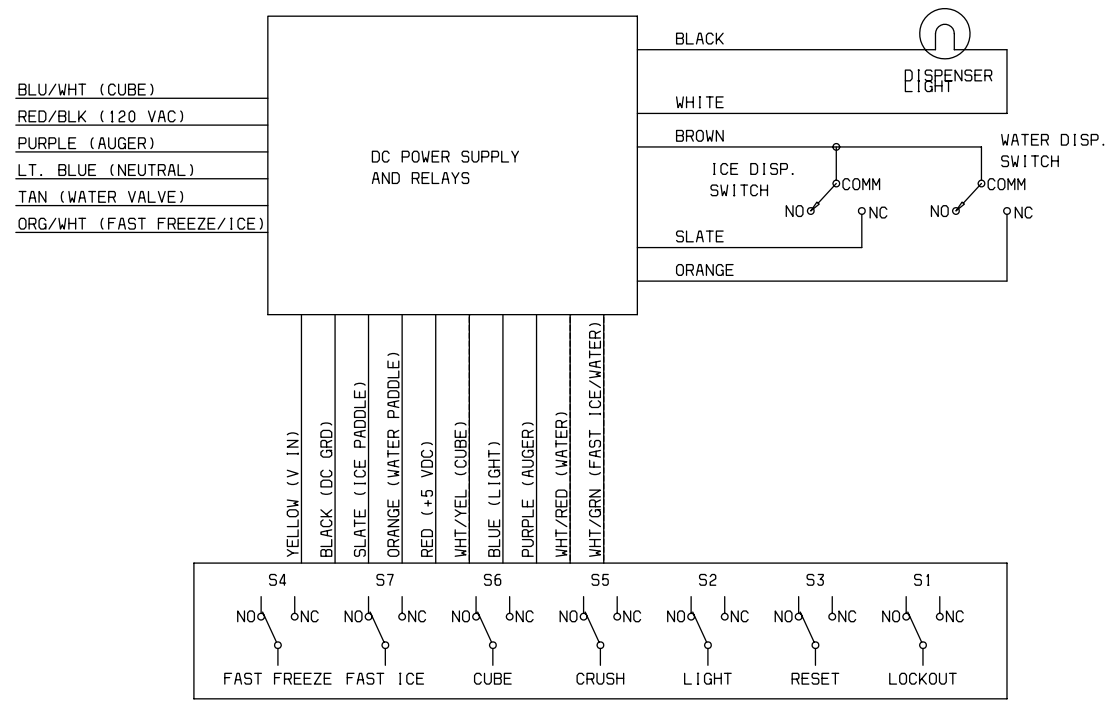

Electro-Mechanical Dispenser

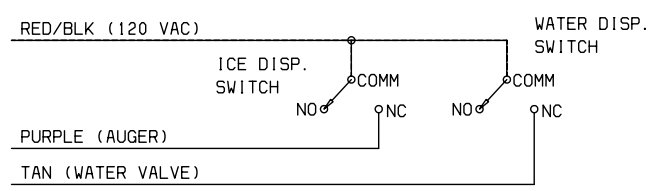

Compressor Wiring

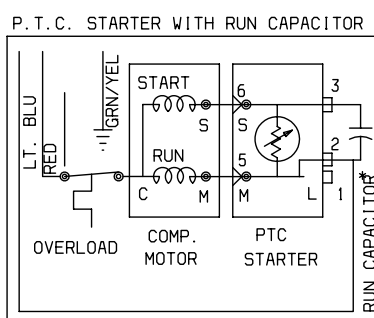

* CAPACITOR IS ONLY USED WITH SOME P.T.C. MODELS.

SERVICE DATA SHEET

240389601

ICE & WATER - AUTOMATIC DEFROST

IDE BY SIDE MODELS

PERFORMANCE DATA NO LOAD AND NO DOOR OPENINGS AT MID-POINT CONTROL SETTING				
Type A With Run/Start Capacitor	65°F (18°C) Ambient	90°F (32°C) Ambient		
Operating Time	32 to 40%	55 to 65%		
Freezer Temperature	0° to 4°F -18° to -16°C	-1° to 3°F -18° to -16°C		
Refrigerator Temperature	34° to 39°F 1° to 4°C	34° to 39°F 1° to 4°C		
Low Side Pressure (cut-in)	5 to 12 psig 34 to 83 kPa	5 to 12 psig 34 to 83 kPa		
Low Side Pressure (cut-out)	-2 to 2 psig -14 to 14 kPa	-2 to 2 psig -14 to 14 kPa		
High Side Pressure (Last 1/3 of cycle)	90 to 115 psig 621 to 793 kPa	130 to 155 psig 896 to 1069 kPa		
Wattage (Last 1/3 of cycle)	120 to 150	130 to 160		
Amps (Running)	1.2 to 1.5	1.2 to 1.5		
Base Voltage	115 VAC	115 VAC		
DEFROST SPECIFICATIONS				
Cabinet Size	Thermostat		Heater	
	Cut-in	Cut-out	Watts	Ohms
23' & 26'	25°F -4°C	47°F 8°C	450	30
Defrost 30 Minutes Every 8 Hours of Compressor Run Time				
CONDENSER FAN MOTOR				
Watts	RPM	Amps		
7	1100 CW Opposite Shaft	.1 Running		
ICE MAKER SPECIFICATIONS				
Electrical	115 Volts	60 Hertz		
Thermostat	Opens at 48°F (9°C)	Closes at 15°F (-9°C)		
Heater Wattage	165			
ICE MAKER CONNECTOR PLUG CONNECTIONS				
Wire Number	Wire Color	Connects to:		
1	Green/Yellow	Ground		
2	Yellow	Water Valve		
3	Black	Line		
4	Lt. Blue	Neutral		

IMPORTANT SAFETY NOTICE

The information provided herein is designed to assist qualified repair personnel only. Untrained persons should not attempt to make repairs due to the possibility of electrical shock. Disconnect power cord before servicing.

IMPORTANT

If any green grounding wires are moved during servicing, they must be returned to their original position and properly secured.

CAUTION: All electrical parts and wiring must be shielded from torch flame. Do not allow torch to contact insulation; it will char at 200°F and flash ignite (burn) at 500°F. Excessive heat will distort the plastic liner.

ICE MAKER INFORMATION

Test Cycling

Remove cover by inserting screwdriver in notch at bottom and prying cover from housing. Use screwdriver to rotate motor gear counterclockwise until holding switch circuit is completed. (See Figure 1.) All components of ice maker should function to complete the cycle.

Water Fill Volume

The water fill adjustment screw will change the fill time. (See Figure 1.) One full turn is equal to 20cc (.68 oz.). The correct fill is 102 to 130cc (3.4 to 4.3 oz.). When a water valve is replaced, the fill volume must be checked.

ATTENTION SERVICERS

Get a HELPING HAND by visiting the Electrolux Home Product Web Site where you can access Service Bulletins, New and Old Product Repair Tips, Service Kits, an interactive Service Request Form, and FAQ's. Visit the site at:

<http://www.frigidaire.com/tip>

User Name: service

Password: tip

And now available at <http://www.frigidaire.com> are the following:

- Wiring Diagrams
- Owner's Guides
- Installation Instructions
- Parts Catalogs

Figure 1

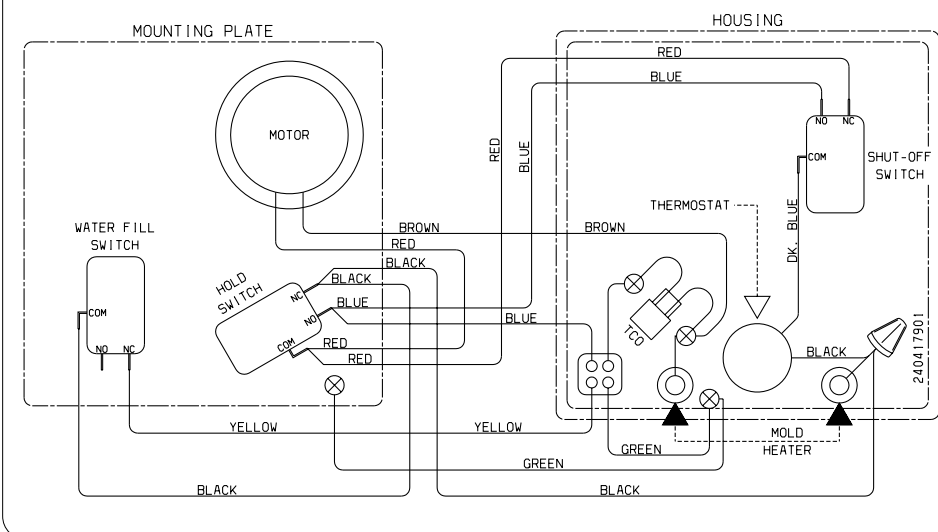
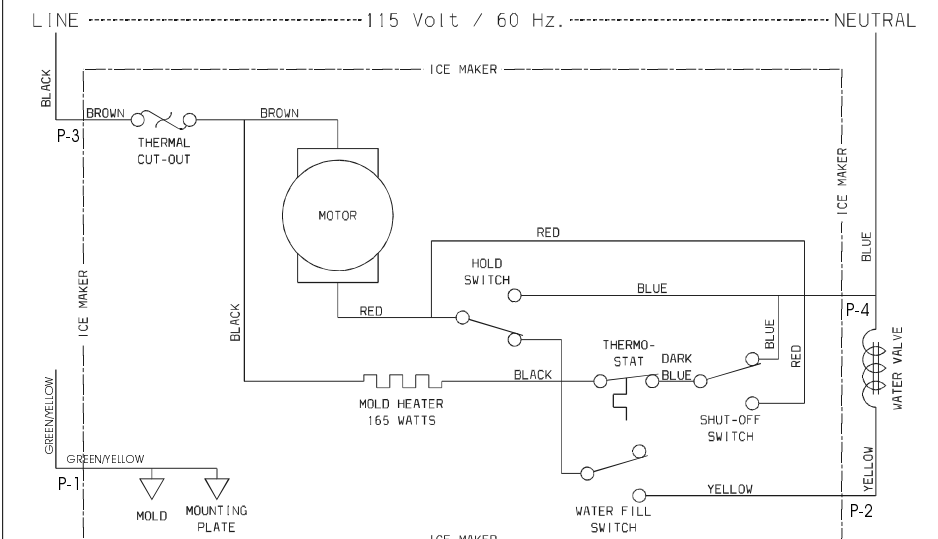
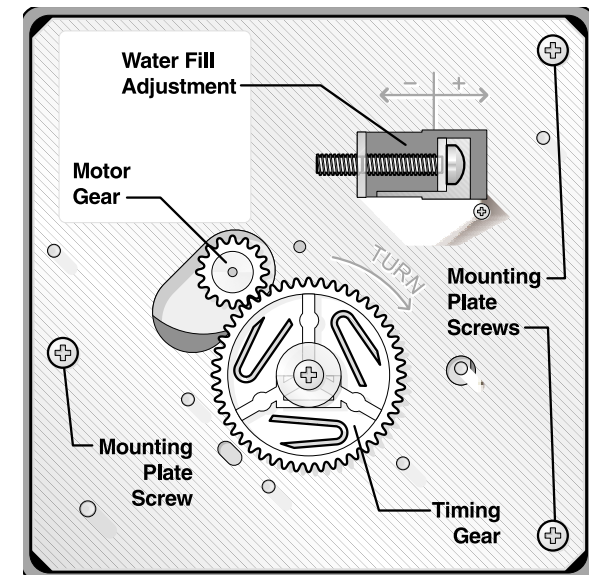

SERVICE DATA SHEET

240389603

ICE & WATER - AUTOMATIC DEFROST

SIDE BY SIDE MODELS

PERFORMANCE DATA NO LOAD AND NO DOOR OPENINGS AT MID-POINT CONTROL SETTING				
Type A With Run/Start Capacitor	65°F (18°C) Ambient	90°F (32°C) Ambient		
Operating Time	32 to 40%	55 to 65%		
Freezer Temperature	0° to 4°F -18° to -16°C	-1° to 3°F -18° to -16°C		
Refrigerator Temperature	34° to 39°F 1° to 4°C	34° to 39°F 1° to 4°C		
Low Side Pressure (cut-in)	5 to 12 psig 34 to 83 kPa	5 to 12 psig 34 to 83 kPa		
Low Side Pressure (cut-out)	-2 to 2 psig -14 to 14 kPa	-2 to 2 psig -14 to 14 kPa		
High Side Pressure (Last 1/3 of cycle)	90 to 115 psig 621 to 793 kPa	130 to 155 psig 896 to 1069 kPa		
Wattage (Last 1/3 of cycle)	120 to 150	130 to 160		
Amps (Running)	1.2 to 1.5	1.2 to 1.5		
Base Voltage	115 VAC	115 VAC		
DEFROST SPECIFICATIONS				
Cabinet Size	Thermostat		Heater	
	Cut-in	Cut-out	Watts	Ohms
23' & 26'	25°F -4°C	47°F 8°C	450	30
(Adaptive) Defrost up to 30 Minutes Every 8 to 72 Hours of Compressor Run Time				
CONDENSER FAN MOTOR				
Watts	RPM	Amps		
7	1100 CW Opposite Shaft	.1 Running		
ICE MAKER SPECIFICATIONS				
Electrical	115 Volts	60 Hertz		
Thermostat	Opens at 48°F (9°C)	Closes at 15°F (-9°C)		
Heater Wattage	165			
ICE MAKER CONNECTOR PLUG CONNECTIONS				
Wire Number	Wire Color	Connects to:		
1	Green/Yellow	Ground		
2	Yellow	Water Valve		
3	Black	Line		
4	Lt. Blue	Neutral		

IMPORTANT SAFETY NOTICE

The information provided herein is designed to assist qualified repair personnel only. Untrained persons should not attempt to make repairs due to the possibility of electrical shock. Disconnect power cord before servicing.

IMPORTANT

If any green grounding wires are moved during servicing, they must be returned to their original position and properly secured.

CAUTION: All electrical parts and wiring must be shielded from torch flame. Do not allow torch to contact insulation; it will char at 200°F and flash ignite (burn) at 500°F. Excessive heat will distort the plastic liner.

ICE MAKER INFORMATION

Test Cycling

Remove cover by inserting screwdriver in notch at bottom and prying cover from housing. Use screwdriver to rotate motor gear counterclockwise until holding switch circuit is completed. (See Figure 1.) All components of ice maker should function to complete the cycle.

Water Fill Volume

The water fill adjustment screw will change the fill time. (See Figure 1.) One full turn is equal to 20cc (.68 oz.). The correct fill is 102 to 130cc (3.4 to 4.3 oz.). When a water valve is replaced, the fill volume must be checked.

ATTENTION SERVICERS

Get a HELPING HAND by visiting the Electrolux Home Product Web Site where you can access Service Bulletins, New and Old Product Repair Tips, Service Kits, an interactive Service Request Form, and FAQ's. Visit the site at:

<http://www.frigidaire.com/tip>

User Name: service

Password: tip

And now available at <http://www.frigidaire.com> are the following:

- Wiring Diagrams
- Owner's Guides
- Installation Instructions
- Parts Catalogs

Figure 1

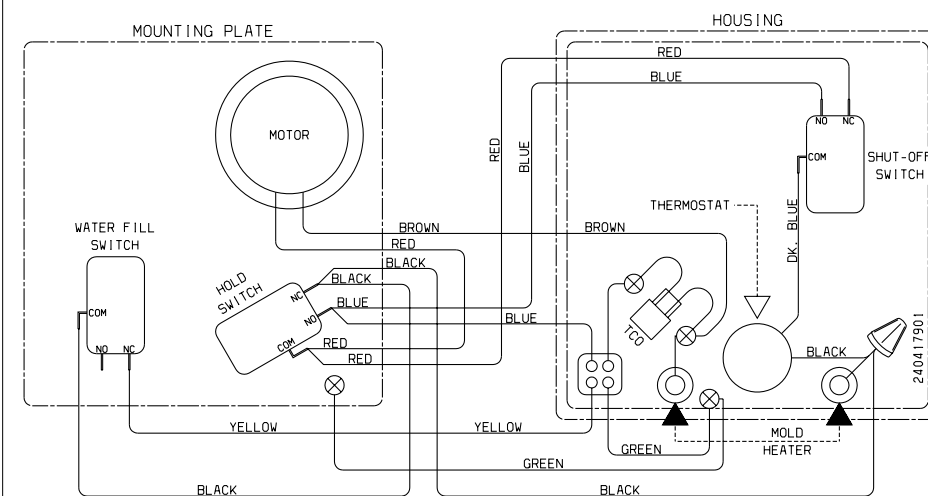
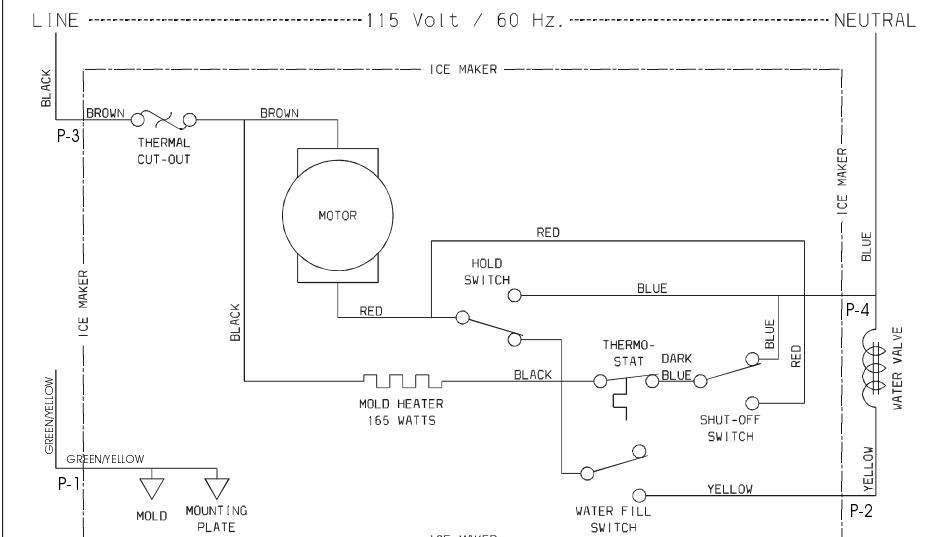
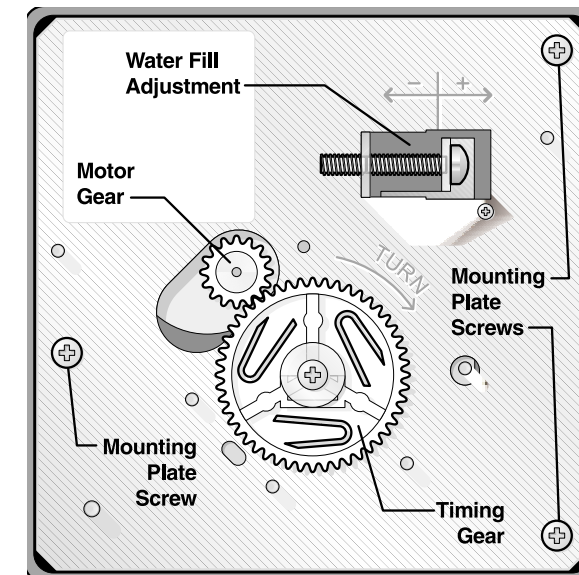

Pictorial Schematic

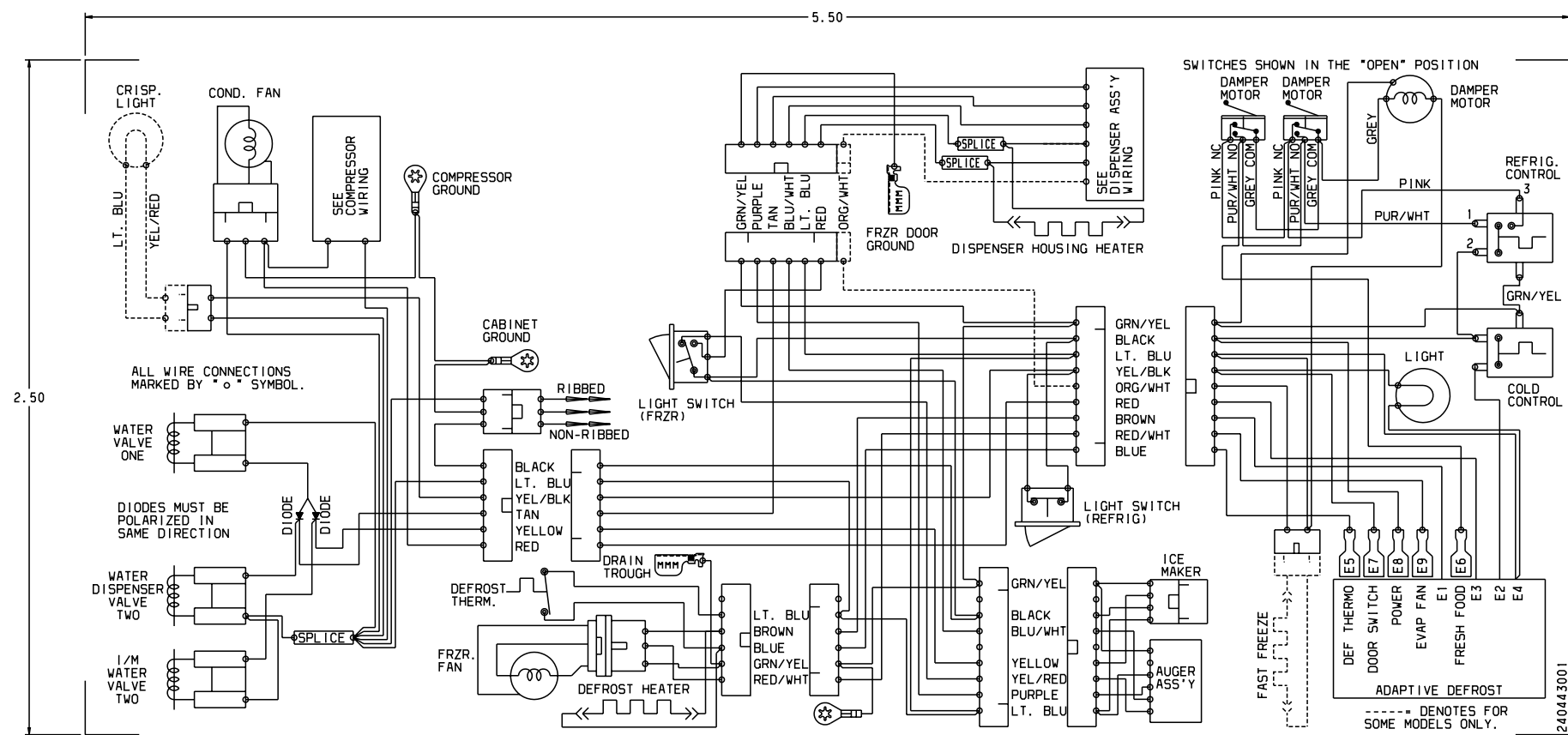

Ladder Schematic

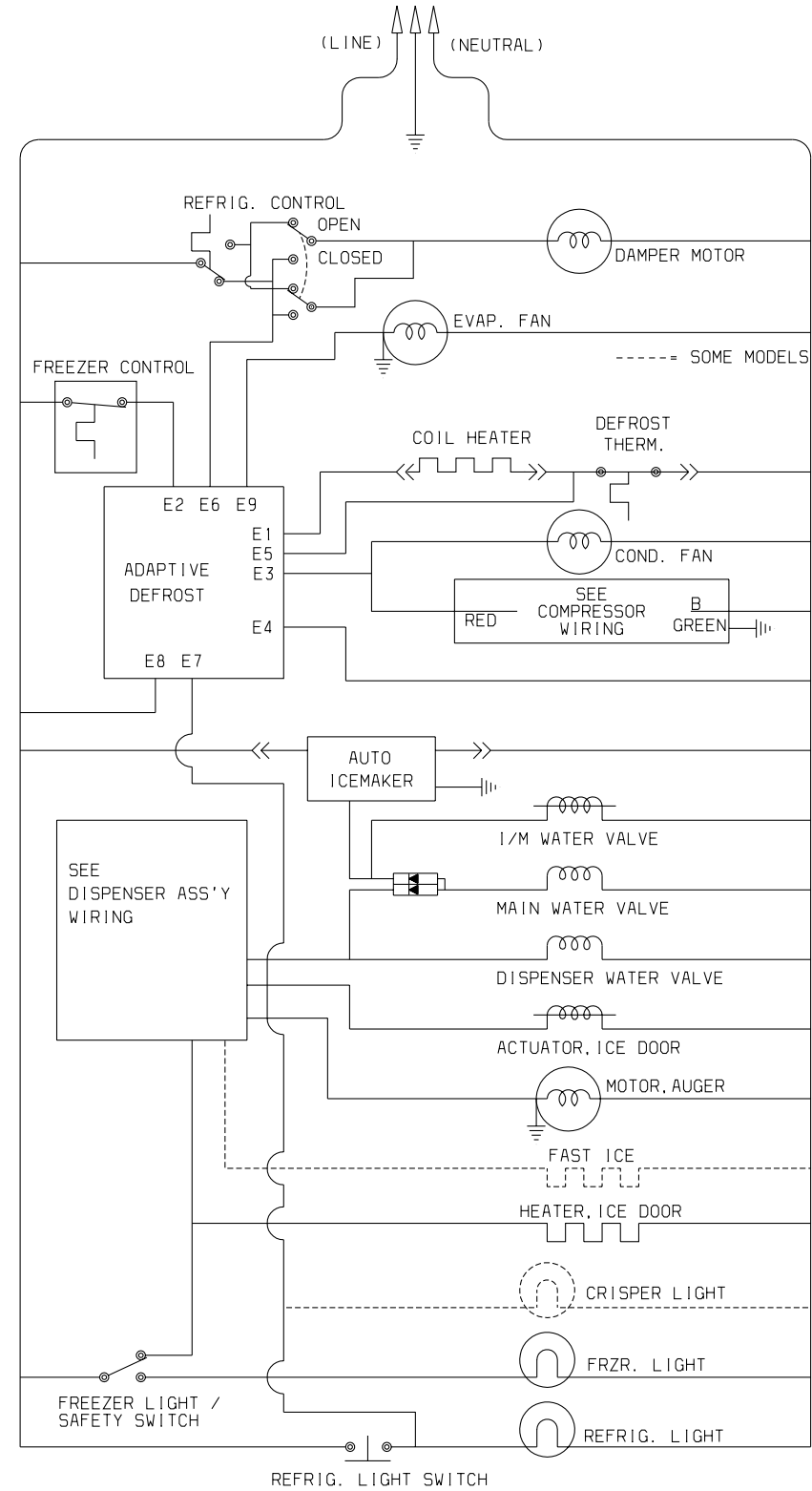

Electronic Dispenser

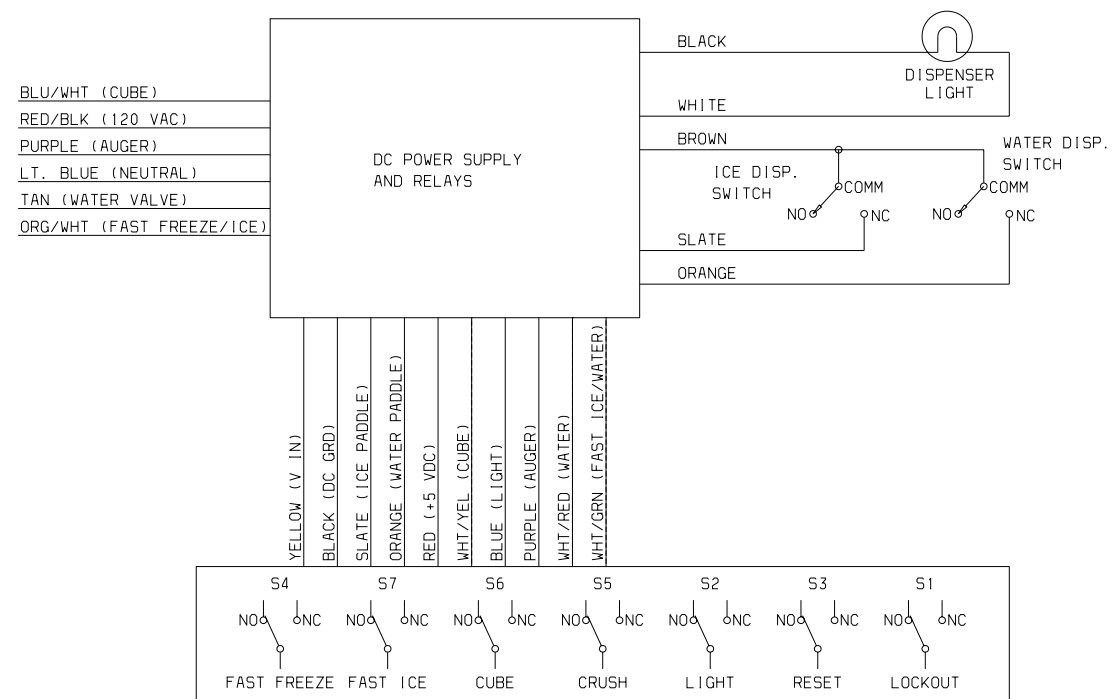

Electro-Mechanical Dispenser

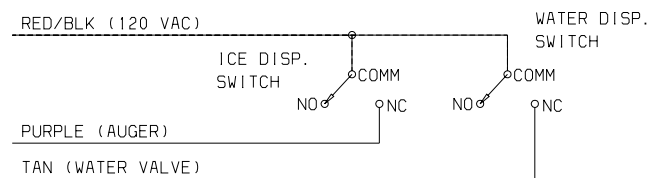

Compressor Wiring

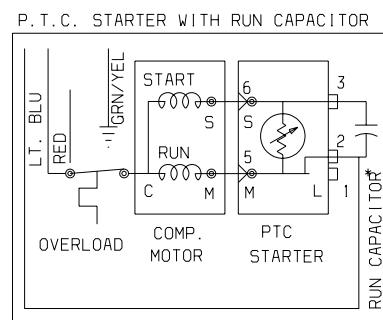

* CAPACITOR IS ONLY USED WITH SOME P.T.C. MODELS.