

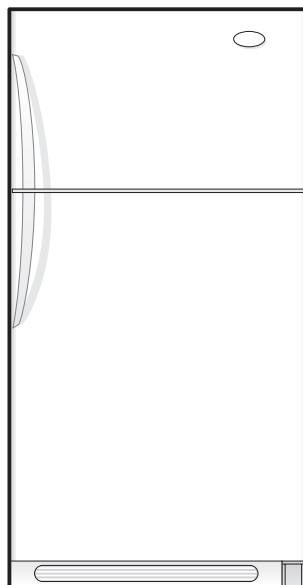

ELECTROLUX HOME PRODUCTS NORTH AMERICA

SERVICE MANUAL



Next Generation Top Mounts
(14', 16' 18' 21' & 23' TNF)

Kelvinator  ***TAPPAN***[®]
Gibson[®]  **White-Westinghouse**[®]
Frigidaire

TABLE OF CONTENTS

SAFE SERVICING PRACTICES	5
---------------------------------------	----------

SECTION A - INSTALLATION INSTRUCTIONS

Uncrating	6
Model and Serial Number	6
Air Circulation	6
Electrical Information	6
Leveling	6
To Adjust The Rollers	6
Door Removal and Reversal Instructions	7
To Remove Freezer Door	7
To Remove Refrigerator Door	7
To Remove Center Hinge	7
To Remove Lower Hinge	7
To Remove Freezer Handle	8
To Remove Refrigerator Handle	8
To Reverse Freezer Handle	8
To Reverse Refrigerator Handle	8
To Reverse Freezer and Refrigerator Door Stops	8
To Install Lower Hinge On Opposite Side	8-9
To Install Center Hinge On Opposite Side	9
To Install Refrigerator Door	9
To Install Freezer Door	9
Other Handle Styles	9
To Remove Figure A13 Styles Handle	9
To Attach Figure 13 Style Handle	10
To Remove Figure A14 Style Handle	10
To Attach Figure 14 Style Handle	10
Trim Removal	10
To Remove Trim	10
To Remove Refrigerator Handle	10
Figure A15 Style Handles	10
Figure A16 Style Handles	10
To Attach Refrigerator Handle	11
Figure A15 Style Handles	11
Figure A16 Style Handles	11
To Attach Trim	11
Removing Stainless Steel Doors and Handles	11
To Remove Doors	11
To Remove Handles	11
Door Alignment	11
Connecting Ice Maker To Water Supply	12
Before Connecting The Water Supply Line, You Will Need	12
To Connect Water Supply Line To Ice Maker Inlet Valve	12

REFRIGERATOR CABINET

Basic Construction	13
Compressor Mounting	13
Insulation and Inner Liner	13
Cabinet Doors and Gaskets	13
Door Rack Replacement	13
Front and Rear Rollers	13
To Remove Front Roller Assembly	14
To Remove Rear Roller	14
Control Housing	14
Cabinet Touch-Up Procedure	14

Lacquer Refinishing	14-15
ELECTRICAL COMPONENTS	
Electrical Grounding	16
Compressor Electrical Components and Circuits	16
Solid State Relay	16
To Check/Replace Relay	16
Overload Protector	17
To Check/Replace Overload Protector	17
Run Capacitor	17
To Check/Replace Run Capacitor	17
Compressor Start Circuit	17
Compressor Run Circuit	17
Compressor Operating Characteristics	18
Compressor Electrical Check	18
Control Thermostat	18
Automatic Defrost Models	18
Temperature Control Mounting	18
To Remove Temperature Control	18
To Remove Refrigerator Light Socket	19
To Remove Freezer Light Socket	19
Light Switch	19
Damper Control	19
Perimeter Hot Tube	19
Evaporator Fan and Motor Assembly	19
To Remove Freezer Fan Motor	19-20
Defrost Timer	21
To Remove Defrost Timer	21
To Check Defrost Timer	21
Defrost Thermostat	21
To Remove Defrost Thermostat	21
To Test Defrost Thermostat	21
Defrost Heater	21
To Remove Defrost Heater	21-22
Adaptive Defrost Control	23
Electrical Requirements	23
Initial Start and Power Interruptions	23
ADC Characteristics	23
Vacation Mode	23-24
System Diagnostics	24
ADC Algorithm Flow Chart	25
AIR CIRCULATION	
Automatic Defrost Models	26
Principles of Automatic Defrost Operation	26
Air Circulation Patterns	26
REFRIGERATION SYSTEM	
Definitions	27
Recovery	27
Recycling	27
Reclaim	27
Safety Warnings	27
Compressor Testing	27
Charging Sealed Systems	27
Soldering	28
Basic Components	28
Perimeter Hot Tube	28
Refrigerant Cycle	28

Low or Low-Side Leak or Undercharge	28-29
Testing For Refrigerant Leaks	29
Checking For Internal (Hot Tube) Leaks	29
Compressor Replacement	29
To Flush The System	29
To Use Dry Nitrogen To Flush The System	29-30
To Use Refrigerant To Flush The System	30
Installing A New Compressor	30-31
Evaporator Replacement	32-33
Heat Exchanger Replacement	33-34
Perimeter Hot Tube Repair Kit	34-35
Bypassing Perimeter Hot Tube - Step 1	34
Installing The Heater Wire - Step 2	35
Installing The Heater Wire - Step 3	35
Condenser Replacement	35-36
Suction Line And Capillary Tube Replacement	36
Filter-Drier Installation	36
Evacuating And Recharging	36
Equipment Needed	36
Installing Evacuation And Recharging Equipment	37
Evacuating System	37
Charging The System	37-38
Final Leak Test	38
R-134a Service Information	39
Verify Refrigerant Type In The System	39
Dedicated Equipment	39
R-134a Refrigeration Systems	39
Miscibility Of R-134a And Ester Oil	39
Water In The Refrigeration System	40
Vacuum Chart	40
Vacuum Pump Maintenance	40
Refrigerant Leaks	41
Leak Detection	41
R-134a Properties	41
HFC-134a, CFC-12 Pressure Temperature Chart	42
R-134a Health And Safety Information	43
Inhalation Toxicity	43
Cardiac Sensitization	43
Spills Or Leaks	43
Skin And Eye Contact	43
Combustibility Of HFC-134a	44
Leak Testing	44
Bulk Delivery And Storage	44
Filling And Charging Operations	44
Refrigerant Recovery Systems	44
Thermal Decomposition	44
ICE MAKER	
Ice Maker For Top Mount Models	45
Front Cover	45
Ice Maker Components	45
Ice Mold	45
Mold Heater	45
Ice Stripper	45
Ice Ejector	45
Water Valve Assembly	45
Thermostat	46

Sensing Arm & Linkage	46
Timing Switches	46
TCO - Thermal Cut-Out	46
Timing Cam & Coupler	46
Timing Gear	46
Motor	46
Fill Trough	46
Wiring	46
Installing Water Supply Line To Ice Maker	47
Test Cycling Ice Maker	47
Water Valve Switch - Water Fill Volume	47
Parts Replacement	47
To Replace Front Cover	47
To Replace Fill Trough & Bearings	48
To Replace Ice Stripper	48
To Replace Ejector Blades	48
To Replace Motor & Switch Mounting Plate	48
To Replace Motor	48
To Replace Water Fill Switch	48
To Replace Hold Switch	49
To Replace Ice Maker Control Shut-Off Switch	49
To Replace Ice Maker Thermostat	49
To Replace TCO	49
To Replace Mold Heater	50
Fault Diagnosis	50
Complaint - Ice Maker Fails To Start	50
Complaint - Ice Maker Fails To Complete Cycle	50
Complaint - Ice Maker Fails To Stop At End Of Cycle	50
Complaint - Ice Maker Continues To Eject When Container Is Full	50
Complaint - Ice Maker Produces Undersized Ice Pieces	50
Ice Maker Testing Procedures	51
Operating Cycle	51
Operating Cycle Illustrations - Manual Cycle	51
Operating Cycle Illustrations - Electrical	51-58
Operating Cycle Illustrations - Mechanical	58-60
Ice Maker - Exploded View	61
Service Data Sheet - Dynamic Condenser	62
Ladder Schematic - Dynamic Condenser Models With Mechanical Defrost Control	63
Ladder Schematic - Dynamic Condenser Models With Adaptive Defrost Control	64
System Wiring Diagram	65
Service Data Sheet - Static Condenser	66
Ladder Schematic - Static Condenser Models	67
Ice Maker Wiring Diagrams - Enlarged View	68
Appendix A - Ice Maker Installation Instructions	A1-7
Appendix B - Diagrams	B1-5
System Diagram	B1
Cabinet Diagram	B2
Doors Diagram	B3
Evaporator Assembly Diagram	B4
Notes	B5

SAFE SERVICING PRACTICES - ALL APPLIANCES

To avoid personal injury and/or property damage, it is important that **Safe Servicing Practices** be observed. The following are some limited examples of safe practices:

1. **DO NOT** attempt a product repair if you doubt your ability to complete it in a safe and satisfactory manner.
2. Before servicing or moving an appliance:
 - Remove power cord from the electrical outlet, trip circuit breaker to the **OFF** position, or remove fuse
 - Turn off gas supply
 - Turn off water supply
3. Never interfere with the proper operation of any safety device.
4. **Use The Correct Replacement Parts Cataloged For This Appliance. Substitutions May Defeat Compliance With Safety Standards Set For Home Appliances.**
5. **GROUNDING:** The standard color code for safety ground wires is **GREEN**, or **GREEN** with **YELLOW STRIPES**. **DO NOT** use ground leads as current carrying conductors. It is **EXTREMELY** important that the service technician reestablish all safety grounds prior to completion of service. Failure to do so will create a hazard.
6. Prior to returning the product to service, ensure that:
 - All electrical connections are correct and secure
 - All electrical leads are properly dressed and secured away from sharp edges, high-temperature components, and moving parts
 - All non-insulated electrical terminals, connectors, heaters, etc. are adequately spaced away from all metal parts and panels
 - All safety grounds (both internal and external) are correctly and securely connected
 - All panels are properly and securely reassembled

WARNING

This service manual is intended for use by persons having electrical and mechanical training and a level of knowledge of these subjects generally considered acceptable in the appliance repair trade. Frigidaire Home Products cannot be responsible, nor assume any liability, for injury or damage of any kind arising from the use of this manual.

SECTION A - INSTALLATION INSTRUCTIONS

UNCRATING

Uncrating instructions are clearly printed on the shipping carton. Under no circumstances should a refrigerator be uncrated until these instructions have been read.

Additional handling and installation information is provided in the "Installation Tips" affixed to the refrigerator door and in the Owner's Use & Care Manual located in one of the drawers inside the refrigerator. Pay particular attention to the information regarding hand trucking, leveling and door alignment.

MODEL AND SERIAL NUMBER

Model and Serial Numbers are found on the Serial Plate located just below the freezer compartment on the left wall of the refrigerator compartment. (See Figure A1)

AIR CIRCULATION

Proper air circulation must be maintained for efficient refrigerator operation. Refer to the Owner's Use & Care Manual for recommended clearances. Install the refrigerator out of direct sunlight and away from the range, dishwasher, or other heat sources.

CAUTION: Do not install the refrigerator where the temperature will drop below 60°F (15°C), or rise above 110°F (43°C) because the compressor will not be able to maintain proper temperatures.

Allow an extra ½" (12mm) on each side for ease of installation in recessed areas. If the hinge side of the unit is placed against a wall, allow a 1¾" (40mm) space between the wall and refrigerator to permit proper door swing.

ELECTRICAL INFORMATION

The refrigerator must be plugged into its own 115 Volt, 60 Hz, AC only electrical outlet. The circuit should be protected by a 15 or 20 Amp circuit breaker or time delay type fuse.

NOTE: If voltage varies by ±10% of 115 volts, performance of the refrigerator may be affected. Operating the refrigerator with insufficient power can damage the compressor.

The refrigerator power cord is equipped with a three prong grounding plug. It must be plugged directly into a properly grounded three prong receptacle. The receptacle must be installed in accordance with local codes and ordinances. **Do not use an extension cord or an adapter plug.**

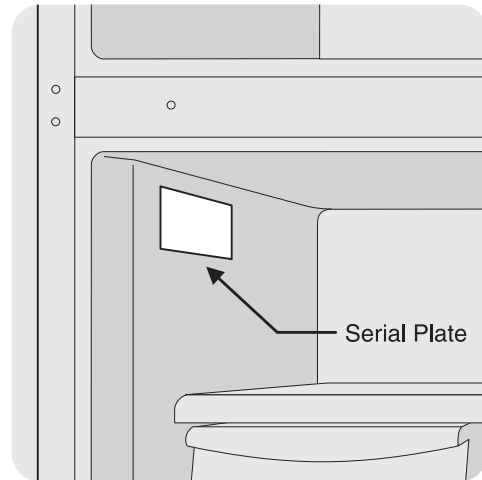

Figure A1

LEVELING

The refrigerator must be leveled with all bottom corners resting firmly on a solid floor. Adjust the front rollers to level the cabinet from side-to-side and front-to-rear. Keep the cabinet as low as possible for stability. Never adjust the cabinet rollers so the front is lower than the rear.

To Adjust The Rollers:

1. Open refrigerator and freezer doors.
2. Remove toe grille by pulling it straight out. (See Figure A2)
3. Adjust front rollers by turning each roller adjusting bolt with adjustable wrench, socket wrench, nutdriver or screwdriver until refrigerator is level and stable. (See Figure A3)
4. Rear rollers are not adjustable.

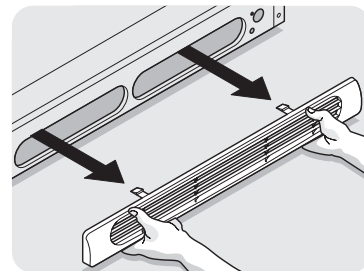

Figure A2

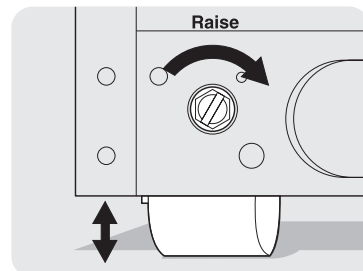
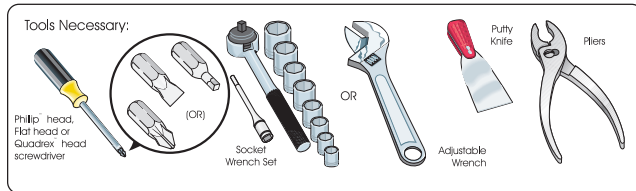

Figure A3

DOOR REMOVAL AND REVERSAL INSTRUCTIONS

This refrigerator is equipped with reversible door hinges. An envelope containing extra plastic hole plugs is included in some models. In the event you need to remove the doors and hinges to get this unit through the door or the customer wants the doors reversed, use the procedure below. Turn the refrigerator control to OFF. Remove all food, bottles, and other items from the door. Begin with freezer door. Completely remove one door before beginning the other.



To Remove Freezer Door: (See Figure A4.)

1. Snap off hinge cover at top of refrigerator.
2. With freezer door closed, remove two hex head screws attaching upper hinge to cabinet.
3. Lift upper hinge up and off.
4. Open freezer door enough to allow it to be lifted off center hinge. Set door aside for reassembly later.
5. Remove hole plugs from opposite side of cabinet top and place in holes where hinge was mounted.

NOTE: Save hinge and screws for reassembly later.

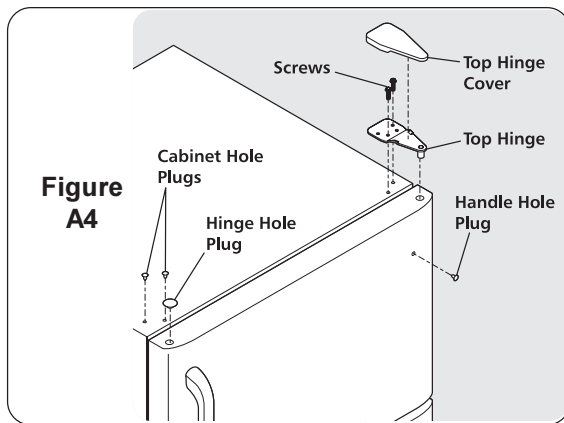

To Remove Refrigerator Door: (See Figures A5 and A6.)

1. Ensure refrigerator door is closed.
2. Remove center hinge pin.

NOTE: Hinge pin is threaded to the center hinge. Use an adjustable wrench to loosen the hinge pin. Ensure the plastic washer stays on the hinge pin.

3. Open refrigerator door enough to allow it to be lifted off lower hinge. Set door aside for reassembly later.

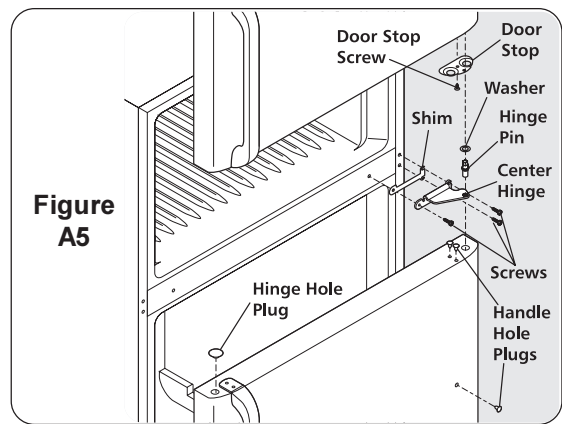

To Remove Center Hinge: (See Figure A5.)

1. Loosen two outer Quadrex head screws on center hinge just enough to take tension off hinge.

NOTE: Outer screws do not have to be completely removed because the hinge is slotted and will slide out easily once the inner screw is removed.

2. Remove inner Quadrex head screw on center hinge.
3. Slide out hinge and shim. Tighten down two outer screws you loosened in step 1.
4. Put inner screw back in and tighten down.

NOTE: Save the hinge, hinge pin, washer and shim for reassembly later.

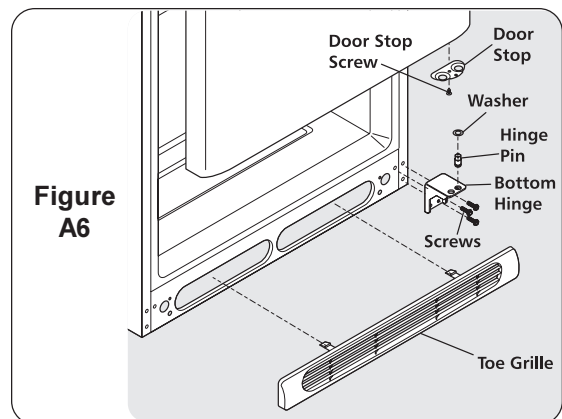

To Remove Lower Hinge: (See Figure A6.)

1. Remove toe grille from front of refrigerator by pulling straight forward.
2. Remove three hex head screws holding lower hinge to cabinet.
3. Put two outer screws back in holes where hinge was and tighten down. Inner screw hole will stay empty.

NOTE: Save the hinge and screw for reassembly later. Ensure that the plastic washer stays with the hinge pin.

To Remove Freezer Handle: (See Figure A7.)

1. Remove two screws attaching handle to bottom of freezer door.
2. Remove button plug near top of handle that is mounted to side of freezer door.
3. Remove screw attaching top of handle to door.

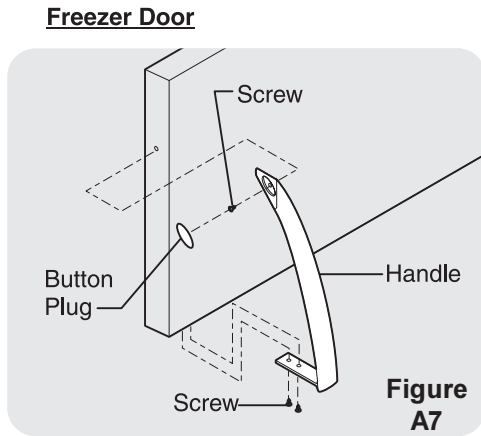

2. Take handle you removed from refrigerator door, rotate 180°, and mount it to freezer door.
3. With two screws, attach bottom of handle to bottom of freezer door.
4. With one screw, attach top of handle to side of freezer door, near top. Cover this screw with a button plug.

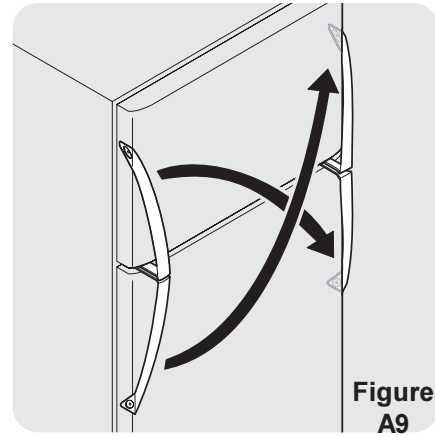

To Remove Refrigerator Handle:
(See Figure A8.)

1. Remove two screws attaching top of handle to door.
2. Remove button plug near bottom of handle that is mounted to side of refrigerator door.
3. Remove screw attaching bottom of handle to door.

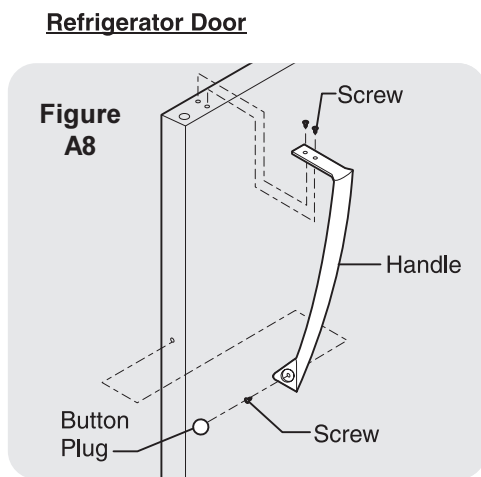

To Reverse Refrigerator Handle:

1. Remove the hole plugs from the opposite side of the door and put them in the holes where the door handle was mounted..

NOTE: There are 3 hole plugs, two on the top of the door and one on the side, about midway down the door.

2. Take handle you removed from freezer door, rotate 180°, and mount it to refrigerator door.
3. With two screws, attach top of handle to top of refrigerator door.
4. With one screw, attach bottom of handle to side of refrigerator door, about midway down door. Cover this screw with a button plug.

To Reverse Freezer and Refrigerator Door Stops:
(See Figures A5 and A6.)

1. Remove Quadrex head screw securing door stop to bottom of freezer door.
2. Attach door stop at opposite end of door with Quadrex head screw and tighten down.
3. Remove Quadrex head screw securing door stop to bottom of refrigerator door.
4. Attach door stop at opposite end of door with Quadrex head screw and tighten down.

To Reverse Freezer Handle: (See Figure A9.)

Both the freezer and refrigerator handles are identical.

1. Remove hole plugs from opposite side of door and put them in holes where door handle was mounted..

NOTE: There are 3 hole plugs, two on underside of door and one on the side, near the top.

To Install Lower Hinge On Opposite Side:
(See Figure A10.)

1. Retrieve lower hinge you saved earlier.
2. Remove two hex head screws from opposite side of cabinet where lower hinge was mounted.
3. Bolt lower hinge to cabinet with three hex head screws. (Remember to retrieve extra screw you had earlier when you removed the lower hinge.) Ensure bolts are tight.

4. Move hinge pin to empty hole on hinge pin.

NOTE: Hinge pin is threaded to the lower hinge. Use an adjustable wrench to loosen the hinge pin for removal and again to tighten in the other hole. Ensure the plastic washer stays on the hinge pin.

To Install Center Hinge: (See Figure A11.)

1. Retrieve center hinge and shim you saved earlier.
2. Loosen two outer Quadrex head screws on opposite side of cabinet just enough to allow hinge to slide between screws and cabinet.

NOTE: Outer screws do not have to be completely removed because the hinge is slotted and will slide in.

3. Remove inner Quadrex head screw on opposite side of cabinet.
4. Slide center hinge and shim into two Quadrex head screws you loosened.
5. Put inner screw back in and tighten down.
6. Tighten down two outer screws.

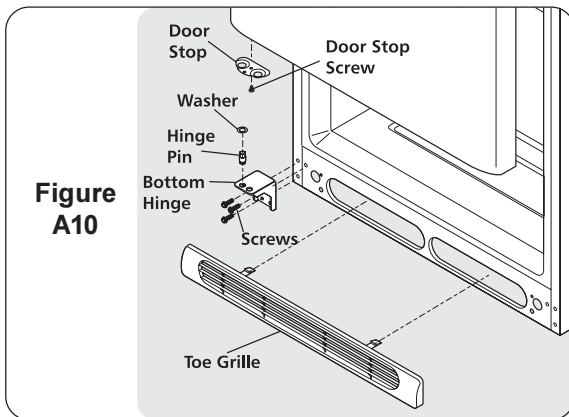

Figure A10

To Install Refrigerator Door:

(See Figures A10 and A11.)

1. Retrieve center hinge pin you saved earlier.
2. Position refrigerator door on lower hinge. Align door with edge of cabinet and close door.

NOTE: You may have to hold the door until the center hinge pin is installed.

3. Insert center hinge pin through center hinge and refrigerator door and tighten.

NOTE: Hinge pin threads into the center hinge. Use an adjustable wrench to tighten the hinge pin. Ensure that the plastic washer stays on the hinge pin.

To Install Freezer Door: (See Figure A12.)

1. Retrieve top hinge you saved earlier.
2. Remove two hex head screws from top of cabinet.
3. Position freezer door on center hinge. Align door with edge of cabinet and close door.
4. Position top hinge to freezer door and top of cabinet.
5. Secure hinge to top of cabinet with two hex head screws you removed earlier.

6. Return food, bottles, and other articles to doors. Additional adjustment may be necessary after loading door racks. Tighten down two screws securing top hinge to cabinet when you feel alignment is satisfactory.
7. Replace toe grille by pushing straight on.
8. Turn refrigerator control ON and return to previous setting.

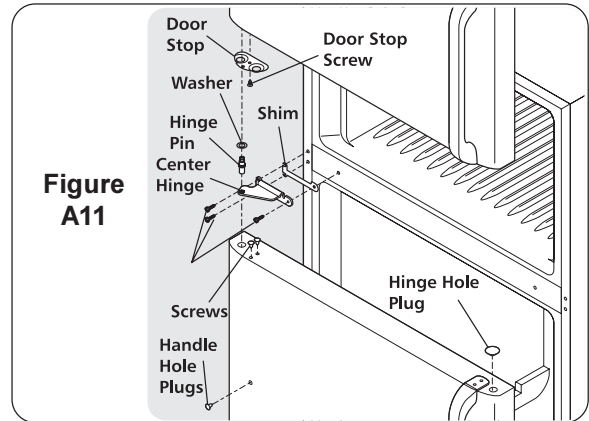

Figure A11

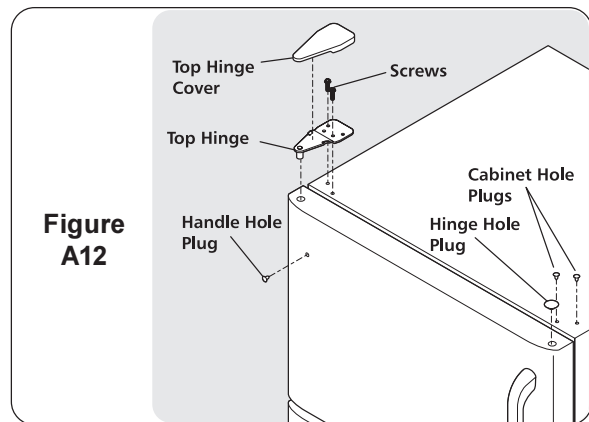

Figure A12

OTHER HANDLE STYLES

NOTE: Some models have pocket handles which are recessed into the sides of the door. If you are reversing the doors on these models, only the hinges will need to be reversed.

To Remove Figure A13 Style Freezer Handle:
(Handles should be reversed while doors are off.)

1. Remove two screws attaching handle to bottom of freezer door.
2. Remove short trim piece by sliding trim straight up and off of handle bracket.
3. Remove screw attaching top of handle to door.
4. **Magnetic Nameplate Models:** Gently pry magnetic nameplate frame from door. Remove nameplate from its frame, turn frame upside down and install in old handle holes. Insert magnetic nameplate into frame.

Self-Adhesive Nameplate Models: Gently peel off nameplate from door and reapply over old handle holes.

To Attach Freezer Handle: (See Figure A13.)

1. Reinstall handle on opposite side, using same hole as nameplate.
2. Attach handle to bottom of door.
3. Slide trim piece straight down onto handle bracket.

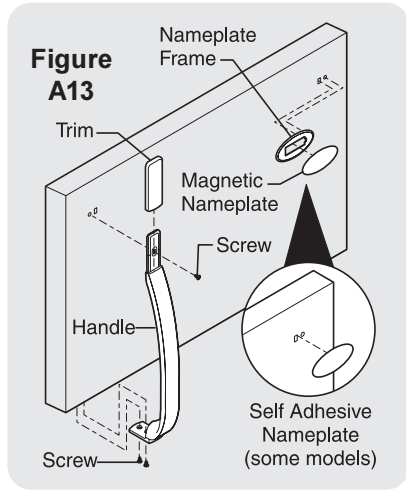

To Remove Figure A14 Style Freezer Handle:
(Handles should be reversed while doors are off.)

1. Remove two screws attaching handle to bottom of freezer door.
2. Swing bottom of handle away from door and slide straight up and off dovetail button.
3. Remove screw and dovetail button and install on other side, using same holes as nameplate.
4. **Magnetic Nameplate Models:** Gently pry magnetic nameplate frame from door. Remove nameplate from its frame, turn frame upside down and install in old handle holes. Insert magnetic nameplate into frame.

Self-Adhesive Nameplate Models: Use putty knife to gently peel off nameplate from door and reapply over old handle holes.

To Attach Freezer Handle: (See Figure A14.)

1. Start with handle offset away from door. Place top of handle over dovetail button, swing handle into upright position and pull downward, locking it into place.
2. Secure bottom of handle with two screws removed earlier.

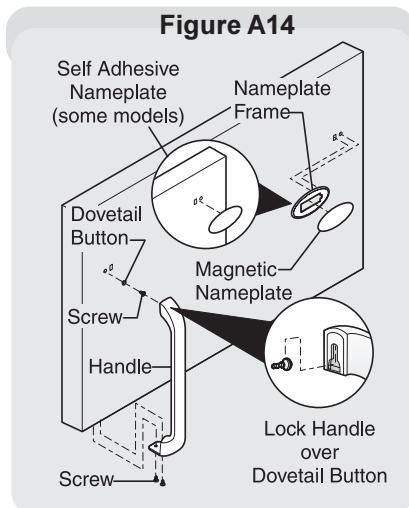

TRIM REMOVAL (Full-Length Trim Models Only)

In some models, the refrigerator door has a full length trim piece which continues from the bottom of the handle to the bottom of the door. The top of the trim attaches to the handle bracket (Figure A15) or fits around the base of the handle (Figure A16). An adhesive trim lock is positioned about halfway down. The bottom of the trim is held in place by either an adhesive trim lock, or a trim lock with two prongs inserted into a hole on the face of the door.

To Remove Trim:

1. Remove trim by gently pulling trim lock areas out and away from door.
2. When trim is free from door, slide trim straight down and away from base of handle.

NOTE: For models with short handle trim, remove by sliding trim straight down and off handle bracket.

To Remove Refrigerator Handle:

(Handles should be removed while doors are off.)

Figure A15 Style Handles

1. Remove two screws attaching handle to top of refrigerator door.
2. Remove screw attaching bottom of handle to door.

Figure A16 Style Handles

1. Remove two screws attaching handle to top of refrigerator door.
2. Swing top of handle away from door and slide handle down and off dovetail button.
3. Remove screw and dovetail button and install on other side, moving hole plugs from corresponding holes to opposite side.

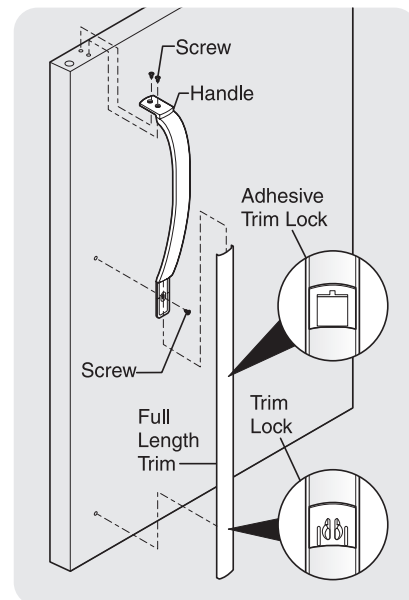

Figure A15

To Attach Refrigerator Handle:

Figure A15 Style Handles

1. Secure bottom of handle with screws.
2. Secure top of handles with screws.

Figure A16 Style Handles

1. Start with handle offset away from door. Place top of handle over dovetail button, swing handle into an upright position and pull forwards, locking it into place.
2. Secure top of handle with screws.

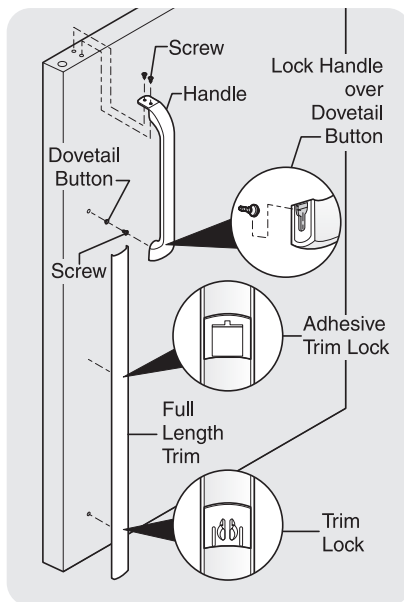

Figure A16

To Attach Trim:

1. Slide both trim locks out of trim.
2. Insert new adhesive trim locks contained in your literature packs.

NOTE: Trim lock must be removed and installed by sliding over the two donut shaped areas.

3. Install trim to handle by sliding under base of handle. Carefully align trim and press down at trim lock locations.
4. Replace hole plug on opposite side. Use rubbing alcohol to remove any adhesive residue from old trim lock locations.

REMOVING STAINLESS STEEL DOORS AND HANDLES

CAUTION: Use care when using tools near surface of stainless steel doors to avoid scratching.

To Remove Doors: (See Figure A17.)

Stainless steel doors are not reversible. Follow these steps to remove doors.

1. Remove toe grille and top hinge cover.
2. Remove top hinge and lift freezer door off of center hinge pin. Set door aside.

3. Unscrew center hinge pin using adjustable wrench and save for reassembly. Ensure plastic washer stays on hinge pin.
4. Lift refrigerator off of bottom hinge and set aside.
5. Remove center hinge and shim by removing inside screw and loosening two outside screws enough to allow hinge to slide out.
6. Remove bottom hinge. Reinsert two outside screws in holes and tighten.
7. Reverse steps 1-6 to reinstall doors.

To Remove Handles:

1. Firmly hold freezer handle while loosening set screws with 3/32" allen wrench. Remove freezer handle.
2. Repeat step 1 for refrigerator door.

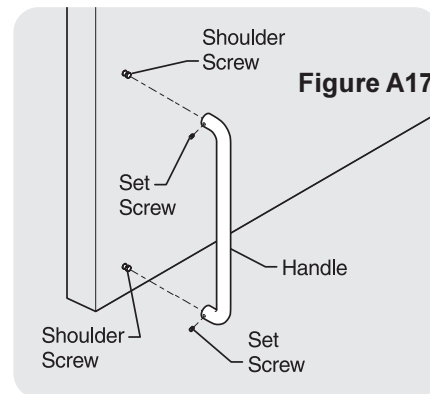

DOOR ALIGNMENT

The center hinge on all models, and the lower hinge on models without a Toe Grille, have mounting holes with little or no clearance. Alignment adjustments are very limited with the exception of adding or removing shims or spacers.

There may be instances when the door gaskets will not form a seal on the hinge side of the door immediately after reversing the door swing, particularly when gasket temperature is below 76°F, or when the refrigerator is in operation. That portion of the gasket now on the hinge side of the doors (formerly on handle side) has a slightly compressed accordion fold section that has set in place. The accordion folds must be relaxed for the gasket to form a seal. The gasket will relax (expand) and seal in sufficient time.

To accelerate the expansion of the accordion fold section, open the doors and pull outward on the gaskets progressively from top to bottom of door. Close doors and check for a seal. Repeat the procedure if necessary. If gaskets do not magnetically form a complete seal within several minutes, warm the gaskets using a 150 watt lamp or suitable heating device.

CAUTION: Be careful not to overheat gasket.

With the doors closed, direct the heat on the entire length of the gasket until a seal is formed.

CONNECTING ICE MAKER TO WATER SUPPLY

WARNING: To avoid electric shock, which can cause death or severe personal injury, disconnect the refrigerator from electrical power before connecting a water supply line to the refrigerator.

CAUTION: To Avoid Property Damage:

- Copper tubing is recommended for the water supply line. Water supply tubing made of 1/4" plastic is not recommended since it greatly increases the potential for water leaks. Manufacturer will not be responsible for any damage if plastic tubing is used for supply line.
- **DO NOT** install water supply tubing in areas where temperatures fall below freezing.
- Connect the ice maker to a potable water source that is not tied into a water softening system. Chemicals from the softener may damage the ice maker, causing it to malfunction.

IMPORTANT: Ensure that your water supply line connections comply with all local plumbing codes.

Before Installing The Water Supply Line, You Will Need

- **Basic tools:** adjustable wrench, standard, flat blade screwdriver, and Phillips™ screwdriver.
- Access to a household cold water line with water pressure between 20 and 120 psi.
- A water supply line made of 1/4 inch (6.4 mm) OD, copper tubing. To determine the length of copper tubing needed, measure the distance from the ice maker inlet valve at the back of the refrigerator to your cold water pipe. Then add approximately 7 feet (2.1 meters), so the refrigerator can be moved out for cleaning. See Figure A18.
- A shutoff valve to connect the water supply line to your household water system. (**DO NOT** use a self-piercing type shutoff valve.)
- A compression nut and ferrule (sleeve) for connecting the water supply line to the ice maker inlet valve.

NOTE: Water line kit number 5303917950, available from your appliance dealer at additional cost, contains 25 feet (7.6 meters) of 1/4" OD copper tubing, a saddle type shutoff valve (nonpiercing), (2) 1/4" brass compression nuts, (2) ferrules/sleeves, and instructions for installing a water supply line.

To Connect Water Supply Line To Ice Maker Inlet Valve:

1. Disconnect refrigerator from electric power supply.
2. Place end of water supply line into sink or bucket.

Turn ON water supply and flush supply line until water is clear. Turn OFF water supply at shutoff valve.

3. Unscrew plastic cap from water valve inlet and discard cap.
4. Slide brass compression nut, then ferrule (sleeve), onto water supply line, as shown in figure A18.
5. Push water supply line into water valve inlet as far as it will go (1/4 inch). Slide ferrule (sleeve) into valve inlet and finger tighten compression nut onto valve. Tighten another half turn with a wrench; **DO NOT** over tighten.
6. With steel clamp and screw, secure water supply line to rear panel of refrigerator at location shown in Figure A18.
7. Coil excess water supply line (about 2 1/2 turns) behind refrigerator as shown in Figure A18 and arrange coils so they do not vibrate or wear against any other surface.
8. Turn ON water supply at shutoff valve and tighten any connections that leak.
9. Reconnect refrigerator to electric power supply.
10. To turn ice maker on, lower wire signal arm. (See ice maker front cover for on/off position of arm.)

IMPORTANT: It takes approximately 24 hours for the ice maker to begin producing ice. Air in new plumbing lines may cause the ice maker to cycle two or three times before making a full tray of ice. New plumbing may cause ice to be discolored or have poor flavor. Discard ice made during the first 24 hours.

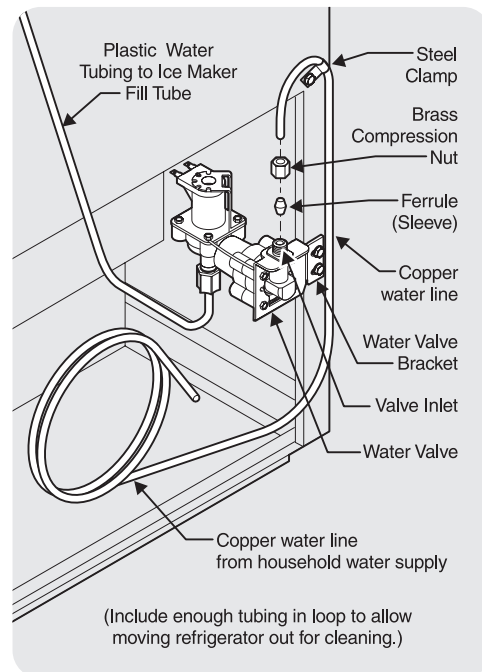

Figure A18

SECTION B - REFRIGERATOR CABINET

BASIC CONSTRUCTION

Next Generation models have clean back cabinets and/or forced air condensers. The condenser is located under the cabinet bottom. The cabinet wrapper consists of a one-piece top and sides formed of prepainted steel, with an interlocking, snap-in, galvanized steel back panel. A separate steel frame is attached to the cabinet bottom. The compressor compartment houses the compressor, condenser, and fan motor.

All cabinet seams have special sealing materials applied as vapor barriers, prior to installation of the inner liner and foam insulation.

COMPRESSOR MOUNTING

All Next Generation models with a dynamic condenser have a unitary drain pan assembly that is mounted to the bottom of the refrigerator cabinet just behind the toe grille. Models with a static condenser use a different drain pan that mounts on top of the compressor. (See Figure B1.)

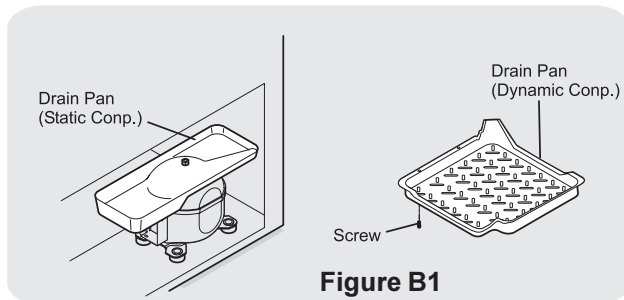

The compressor is mounted on rubber grommets with metal inserts, then bolted to the base using four Hex head, 14-28 shoulder screws. (See Figure B2)

INSULATION AND INNER LINER

The cabinet wrapper and compartment liner are bonded together with a core of "Urethane" foam insulation to form a slim three-ply wall of single-unit construction.

The one piece inner liner is vacuum formed of tough corrosion-proof ABS/HIPS plastic material. The liners are not removable.

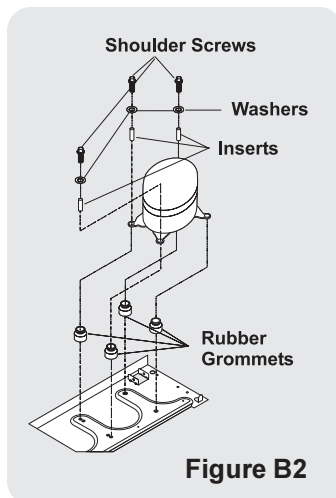

CABINET DOORS AND GASKETS

The exterior door panels are made from one piece of heavy gauge, deep drawn, cold-rolled steel. A wide flange at the periphery is formed integral with the exterior door panel.

Next generation model doors are filled with rigid Urethane foam insulation prior to assembly of the inner panel and door gasket.

The door inner panels are vacuum formed from high strength plastic.

Door Rack Replacement

The Door Rack and Door Rack Supports are removed as an assembly. To remove, push in on the tabs located on the inside of the Door Rack Supports and pull the assembly out of the inner door panel (See Figure B3).

To remove Door Rack Supports from the Door Rack, insert a small flat bladed screwdriver between the Door Rack Support and the Door Rack tab, and pull the Door Rack Support off.

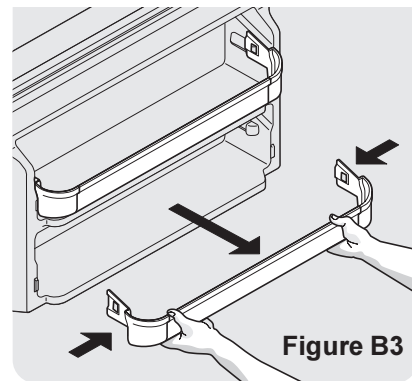

FRONT AND REAR ROLLERS

The front roller is mounted with two screws to the cabinet base and one screw to the front of the cabinet. (See Figure B4) The adjustment screw at the top of the roller is turned clockwise to raise the cabinet, and counter-clockwise to lower the cabinet (See Figure B5). While making adjustments, slightly raise the cabinet to reduce the strain on the roller assembly.

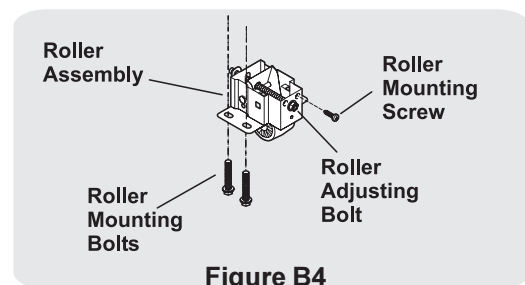
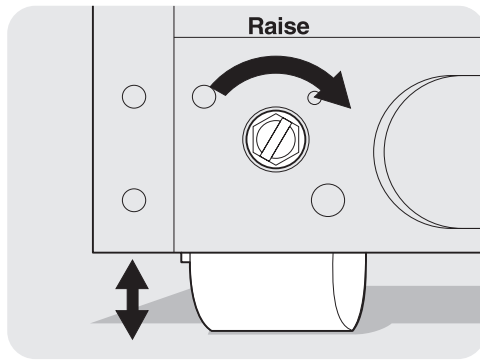

Figure B5



To Remove Front Roller Assembly:

1. Disconnect refrigerator from electrical power.
2. Raise and support cabinet.
3. Remove two bolts securing roller to bottom of refrigerator.
4. Remove one screw securing roller to front of cabinet. Roller should fall free.
5. Reassemble in reverse order.

To Remove Rear Roller: (See Figure B6)

NOTE: The rear roller assembly is mounted to the bottom of the compressor base. Raise and support cabinet before removing rear roller.

1. Disconnect refrigerator from electrical power.
2. Raise and support cabinet.

NOTE: The end of the roller pin that protrudes through the roller has been flared to prevent it from slipping out. You will have to squeeze it back together with a pair of pliers before it will slide out for removal.

3. Squeeze flared end of roller pin together using pair of pliers.
4. Pull roller pin free of roller and compressor base. Roller should fall free. If not, you may have to tap roller lightly with hammer to free it from compressor base.
5. Reassemble in reverse order.

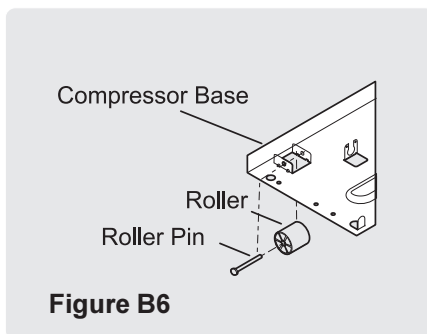

Figure B6

CONTROL HOUSING

The control housing is mounted to the top of the refrigerator compartment with four ¼" screws. The housing contains a Temperature Control Thermostat, Defrost Timer, Light Switch and a Temperature Control Knob. (See Figure B7)

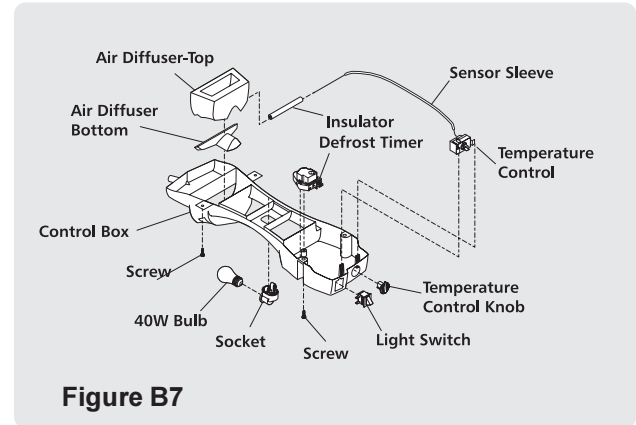

Figure B7

CABINET TOUCH-UP PROCEDURE

Vinyl gaskets are used on all models. Lacquer repairs can be made on all areas of the cabinet except any painted surface that comes in contact with the vinyl gasket. Since prolonged contact of vinyl gaskets with lacquer will soften the lacquer, repairs in these areas should not be attempted.

Lacquer Refinishing

The following steps to touch-up or refinish a acrylic painted cabinet, **except in gasket contact areas**.

1. Sand out spot to be repaired with 360 or 400 wet-or-dry sandpaper. Finish sanding to feather edge with 600 wet-or-dry sandpaper. Wipe area dry. Hand rub with fine rubbing compound (Dupont VZ1090® or equivalent), the area extending at least six inches beyond edges of lacquer repair spot. Wipe compound off and wash area with Naphtha. Dry with clean cloth.
 2. Prepare bare metal with Sol-Kleen® cleaner and rust remover. Reduce cleaner with two parts water, and apply with a clean wet rag. Do not touch painted surface with this cleaner. Stubborn or deep seated rust can be removed by applying cleaner with steel wool.
- NOTE:** Prepare surface of bare metal with Sol-Kleen® regardless if rust is present.
3. Before cleaner dries, wipe surface dry with clean rag.
 4. Wipe over surface thoroughly second time with solution of 50-50 alcohol and water. Wipe again with clean dry rags, preferably new cheesecloth.
 5. Allow to dry for at least 10 to 15 minutes.

6. Apply primer surfacer, reduced by approximately equal parts of lacquer thinner, to build bare metal area up to surrounding surface. Any imperfections which primer has not filled should be knifed out with lacquer type putty glaze.
7. If no putty glaze is used, allow to dry about 30 minutes and, if necessary, sand out lightly with 360 wet-or-dry sandpaper. If putty glaze is used, allow about three hours before sanding with sandpaper and water. Remove sanding residue thoroughly by wiping with clean rag soaked in naphtha. Wiping surface with tack rag will remove dust and lint.
8. Finish repair with two or more coats of lacquer (reduce approximately one part of lacquer to 1½ parts of thinner). Finally, apply mist coat of lacquer thinner to flow out surface.
9. Patched area should be allowed to dry three or more hours before rubbing with compound or polish.

This procedure also applies to the complete refinishing of the cabinet, except gasket contact areas. All damaged areas should be repaired as outlined in steps 1 through 6 above. The overall surface of the cabinet should be sanded thoroughly and cleaned as outlined in step 7.

The cabinet should be given two or more coats of touch-up lacquer and polished as outlined in steps 8 and 9.

SECTION C - ELECTRICAL COMPONENTS

ELECTRICAL GROUNDING

All refrigerators are equipped with a power supply cord incorporating a three-prong grounding plug and a ground wire which is attached to the refrigerator cabinet for protection against shock hazard. Each electrical component is either cabinet mounted or connected through a ground wire to the cabinet to complete the ground. Certain components, such as defrost timers, may be double insulated and do not require a ground wire.

Ensure that the electrical wall receptacle is of the three prong type and is properly grounded in accordance with the National Electrical Code and/or local codes.

COMPRESSOR ELECTRICAL COMPONENTS AND CIRCUITS

The new series of very high efficiency compressor is equipped with all new electrical components consisting of a solid state PTC relay with a thermally operated overload protector, and a run capacitor. (See Figure C1)

Solid State Relay

The solid state relay has no moving parts. It consists of a PTC resistor mounted in a plastic case with appropriate terminals. PTC (Positive Temperature Coefficient) simply denotes a resistor which increases in resistance as its temperature is increased. The self-heating PTC resistor used in the solid state relay has the unique characteristic of changing from low to very high resistance very abruptly, thus serving as an ON-OFF switch. (See Figure C3)

The solid state relay plugs directly onto the compressor start and run terminals. (See Figure C2) Relay terminals 1, 2, and 5 are connected within the relay, as are terminals 3 and 6.

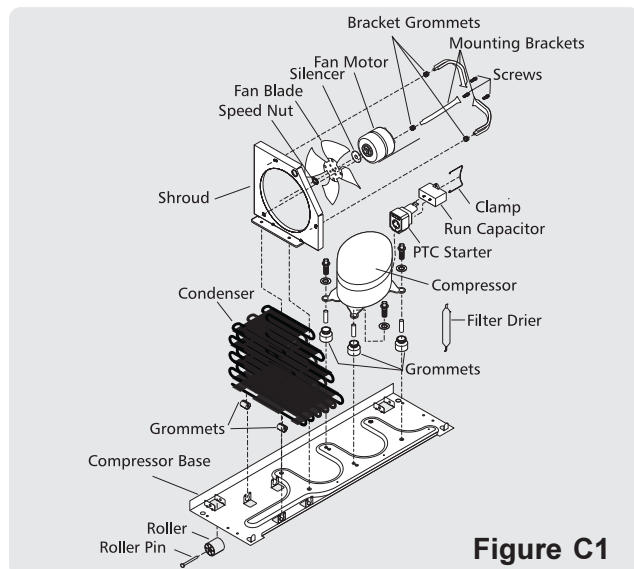

Figure C1

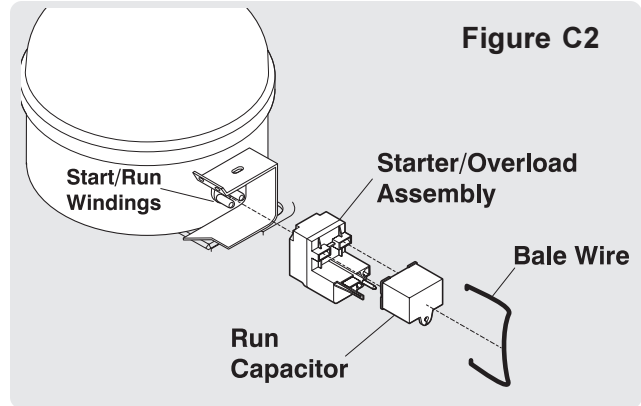

Figure C2

A run capacitor is connected to relay terminals 2 and 3, so it is connected in parallel with the PTC resistor. One side of the 120 VAC power is connected to relay terminal 1. The other side of the line is connected to the overload protector. (See figure C3.)

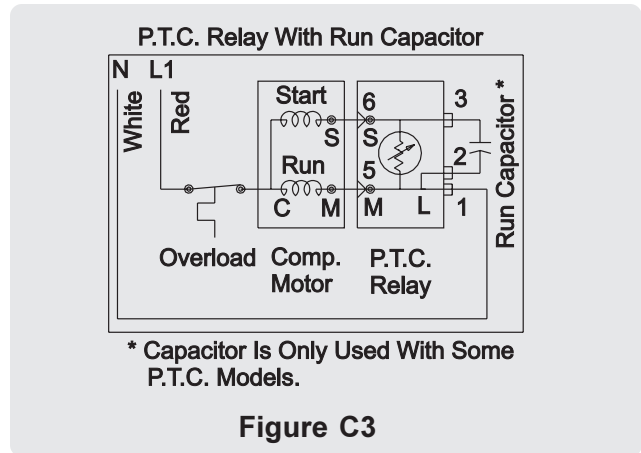

Figure C3

NOTE: There are two Exploded View Diagrams (Cabinet and System) at the end of this section, pages ??, to assist you in troubleshooting.

To Check/Replace Relay

1. Disconnect electrical supply to refrigerator.
2. Remove bale wire holding relay to compressor. (See Figure C2)
3. Remove relay assembly from compressor. (See Figure C2)
4. Use small, flat-bladed screwdriver to disconnect leads to relay assembly.
5. Use flat-bladed screwdriver to gently pry capacitor from relay assembly.
6. Use ohmmeter to check resistance between terminals 5 and 6. Resistance should be 3 to 12 ohms, at normal room temperature. Shorted relay will read 0 ohms. Open relay will read very high or infinite resistance.

- If ohm readings are out of range, replace relay.
- Reverse this procedure to reassemble.

NOTE: When replacing leads to the PTC relay, ensure that locking tabs snap into terminal.

Overload Protector

The overload protector is completely thermally operated. It will open from excessive heat or current. Unlike prior overloads, the internal bimetal is not self-heating, and is not a part of the electrical circuit. The overload has a small built-in coil heater that is in series with the compressor start and run windings (See Figure C3).

To Check/Replace Overload Protector

- Disconnect electrical supply to refrigerator.
- Remove bale wire holding relay to compressor.
- Remove relay assembly from compressor.
- Use flat-bladed screwdriver to gently pry capacitor from relay assembly.
- Use small, flat-bladed screwdriver to disconnect leads to relay assembly. (Note: On some models you will have to remove bale wire and cover, to gain access to relay and overload protector.)
- Use ohmmeter to check resistance between tab terminal and female pin terminal. Overload protector should have less than 1 ohm of resistance at normal room temperature.
- If ohm readings are out of range, install new Starter/Overload Assembly. (See Figure C2)
- Reverse this procedure to reassemble.

NOTE: When replacing leads to the PTC Relay, ensure the locking tabs snap back into the terminal.

Run Capacitor

The run capacitor has permanently attached terminals which are connected to relay terminals 2 and 3.

NOTE: Some models are not equipped with a run capacitor

To Check/Replace Run Capacitor

- Disconnect electrical supply to refrigerator.
- Remove bale wire holding relay to compressor.
- Use small, flat-bladed screwdriver to disconnect leads to relay assembly.
- Use flat-bladed screwdriver and gently pry capacitor from relay assembly.
- Discharge capacitor by shorting across terminals with 500K (1 watt) resistor for one minute.
- Use ohmmeter set on the “**Ohms times 1000**” scale (if available), to check resistance across capacitor wire terminals.

- Needle should jump towards zero ohms and quickly move back to infinity.
- If needle does not move, capacitor is open.
- If needle reads constant value at or near zero ohms, capacitor is shorted out.
- If needle jumps toward zero and then moves back to constant high resistance (not infinity), capacitor has high resistance leak.

- If ohm readings are out of range, replace capacitor.
- Reverse procedures to reassemble.

Compressor Start Circuit

When the compressor circuit is first energized, the solid state relay has low resistance (3-12 ohms), and both the run and start windings are energized to start the compressor. The run capacitor is being bypassed by the relay, and it has a minor function during compressor starting (See Figure C4).

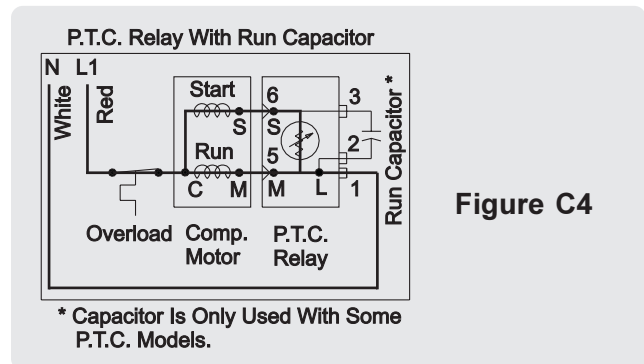

Figure C4

Compressor Run Circuit

When the self-heating solid state relay has reached sufficient temperature, it will abruptly change from low resistance (3-12 ohms) to very high resistance (10-20K ohms) and, in effect, switch off the start windings.

The relay no longer shunts the run capacitor. The run capacitor is now in series with the start windings. The only purpose of the run capacitor is to improve compressor operating efficiency, which it does by correcting the power factor of the compressor motor (See Figure C5).

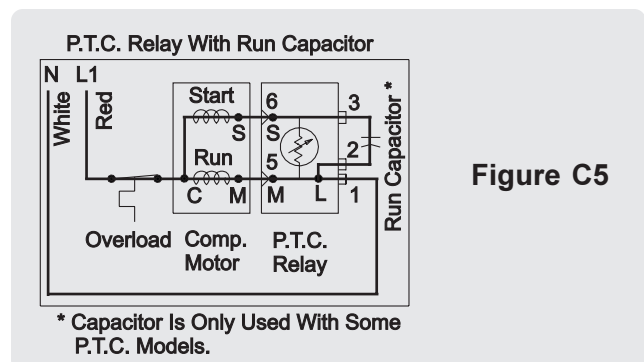

Figure C5

COMPRESSOR OPERATING CHARACTERISTICS

- When the compressor electrical circuit is energized, the start winding current causes the relay to heat and switch off the start winding circuit.

NOTE: The relay will switch off the start winding circuit even though the compressor has not started (as when attempting to restart after momentary power interruption).

- The overload protector is designed and calibrated to open the compressor electrical circuit with locked rotor run winding current only.
- With an open relay, the compressor will not start since there is little or no current to the start windings. The overload protector will open due to high locked rotor run winding current.
- With a shorted relay or capacitor, the compressor will start, and the overload protector will open.
- With an open or weak capacitor, the compressor will start and run. However, the compressor will be operating at reduced efficiency of energy usage.
- If the compressor casing gets too hot, it will shut down on the overload. After the compressor has cooled down, the overload will reset and the compressor will restart.
- In rear mounted condensers, the overload will cycle the compressor on and off if the refrigerator is set in so tight that the air can't circulate around the condenser. In air cooled condensers, the overload will cut the unit off if the condenser becomes blocked or the fan motor stops running.

COMPRESSOR ELECTRICAL CHECK

If the compressor will not run, make a voltage check across the power lead terminals on the PTC Relay and the Overload Protector. (See Figure C5.)

The voltmeter should show line voltage if the thermostat knob is in normal operating position and not in the OFF position. If this check does not show a live circuit, the control thermostat and defrost timer wiring should be checked for loose and/or broken connections.

A control thermostat check can be made by using a piece of wire as a temporary bridge across two thermostat terminals. If the compressor starts and runs with the bridge, the control thermostat is at fault and should be replaced.

If the voltage check shows power supply at the PTC Relay terminals, use a test cord to check the compressor.

If the compressor does not start and run with the test cord, check the line voltage to see if there is more than 10% variation from the rated voltage. If voltage is correct and the compressor will not start and run, replace the compressor.

If the compressor starts and runs with the test cord, replace the PTC Relay.

CONTROL THERMOSTAT

Automatic Defrost Models

The control thermostat is a variable cut-in type. When the thermostat knob is changed from one setting to another, both cut-in and cut-out temperature change. The degrees of temperature change are determined by the knob setting.

Temperature Control Mounting

The temperature control is mounted in a one-piece plastic control housing. The sensing element is attached to the projection on the bottom of the housing, with a single bend (See Figure C6).

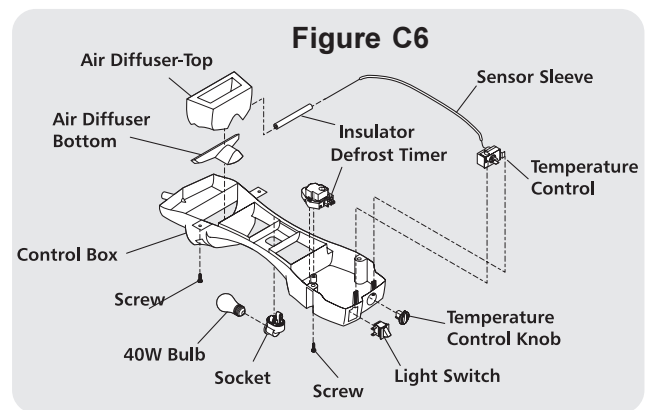

To Remove Temperature Control

1. Disconnect electrical supply to refrigerator.
2. Remove four screws securing housing to top of refrigerator compartment.
3. Unplug moxex connector.
4. Remove Temperature Control knob.
5. To remove Temperature Control from housing, pull back on two tabs and lift Temperature Control out. (See figure C7.)

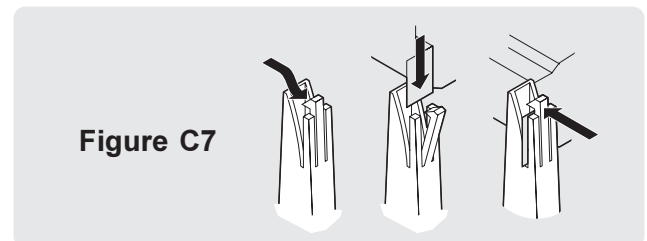

6. Disconnect three terminal lugs connected to control. They may be tight so use needle nose pliers to loosen them from terminals to prevent damaging terminals and lugs.
7. Remove top of Air Diffuser. (It is in there kind of snug, so be careful not to damage it while removing it.)
6. Remove control bulb from housing.
7. Reverse this procedure to complete repairs.

To Remove Refrigerator Light Socket

1. Disconnect electrical supply to refrigerator.
2. Remove four screws securing housing to top of refrigerator compartment. (See Figure C6.)
3. Unplug mox connector.
4. Unscrew light bulb.
5. Disconnect two wires to light socket. (Yellow/Red and Blue wires)
6. Squeeze in on tabs on light socket and push through Control Box.
6. Reverse procedure to complete repairs.

To Remove Freezer Light Socket (See Figure C8)

1. Disconnect electrical supply to refrigerator.
2. Remove freezer section shelves and baskets.
3. Remove two screws securing ice cube tray holder or ice maker (some models).
4. Disconnect ice maker mox plug from wiring harness connector mounted on back freezer wall in upper left hand corner (some models).
5. Remove fan access cover by pressing in on both sides (top and bottom) of access cover and pull forward.
6. Remove light shield by pressing in on tab on bottom of shield and pulling forward.
7. Disconnect three wires to lamp socket. (Yellow/Red and two piggybacked Blue wires)
8. Push in on tabs on light socket and push through coil cover.
6. Reverse procedure to complete repairs.

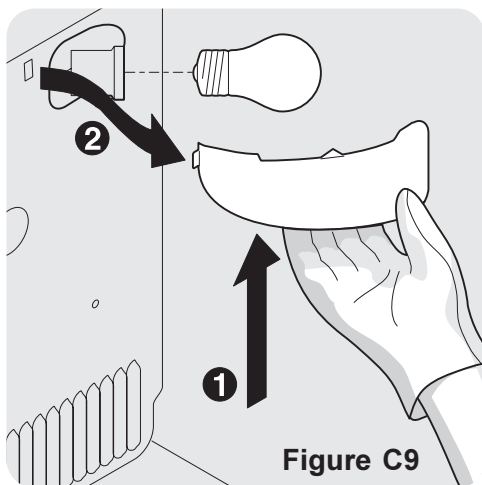

LIGHT SWITCH

The light switch is a door activated, single-pole, single-throw switch (**SPST**). (See Figure C10)

When the door is closed, the light circuit is open (OFF). Push on terminal connectors secure the wiring harness leads to the switch terminals.

To replace the switch, pry the switch out of its mounting, disconnect the wire leads, and replace.

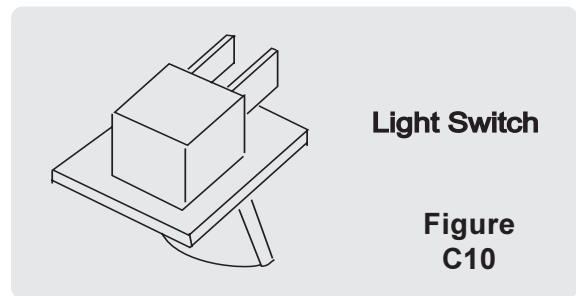

DAMPER CONTROL

The Damper Control regulates the freezer compartment temperature. The Damper Control consists of the Freezer Control Knob and Damper.

When the Freezer Control Knob is moved from a **WARMER** to a **COLDER** setting, the Damper moves, keeping more air generated by the Freezer Fan Assembly inside the freezer compartment.

When the Freezer Control Knob is moved from a **COLDER** to a **WARMER** setting, the Damper moves to allow more air into the refrigerator section.

PERIMETER HOT TUBE / MULLION HEATER

To reduce the possibility of condensation forming on the exterior of the cabinet and between doors in high humidity areas, units are equipped with a perimeter hot tube and/or a center mullion heater.

The perimeter hot tube, which is part of the refrigeration system, is used instead of an electric perimeter heater. Refer to Refrigeration Section E for details.

EVAPORATOR FAN & MOTOR ASSEMBLY

The fan and motor assembly is located behind the freezer compartment air duct directly above the evaporator in the freezer compartment.

The fan is a suction type, pulling air up through the evaporator and blowing it through an air duct behind the liner into the food compartment through the freezer control baffle.

The freezer compartment fan motor is wired in series with the control thermostat and the contacts of the defrost timer, and operates when the control thermostat contacts are closed, except during the defrost cycle.

On current production models, the fan blade is not adjustable and is designed to be pressed onto the motor shaft until it bottoms out against the stop at the front of the fan blade.

To Remove Freezer Fan Motor (See Figure C11)

NOTE: When replacing the fan blade, press the blade onto the motor shaft until the blade bottoms out on the shaft.

1. Disconnect electrical supply to refrigerator.
2. Remove freezer section shelves and baskets.
3. Remove two screws securing ice cube tray holder or ice maker (some models).
4. Disconnect ice maker molex plug from wiring harness connector mounted on back freezer wall in upper left hand corner (some models).
5. Remove fan access cover by pressing in on both sides (top and bottom) of access cover and pull forward.
6. Remove Light Shield by pressing in on tab on bottom of shield and pulling forward. Remove light bulb.
7. Remove four screws securing evaporator coil cover.
8. Press in on tabs of wiring harness connector and push through opening in fan access cover.
9. Disconnect four wires from evaporator fan motor. (Green/Yellow, Red and two piggybacked Blue wires)
10. Disconnect three wires to lamp socket. (Yellow/Red and two piggybacked Blue wires)
11. Remove Evaporator Coil Cover.
12. Remove two screws securing fan motor assembly to evaporator coil cover.
13. Remove fan blade. (It pulls straight off.)
14. Remove two screws securing front motor bracket to rear mounting bracket.
15. Check resistance of motor by reading across two terminals on coil. Resistance should read high on R1 scale. If not, replace motor.
16. Reverse procedure to complete repairs.

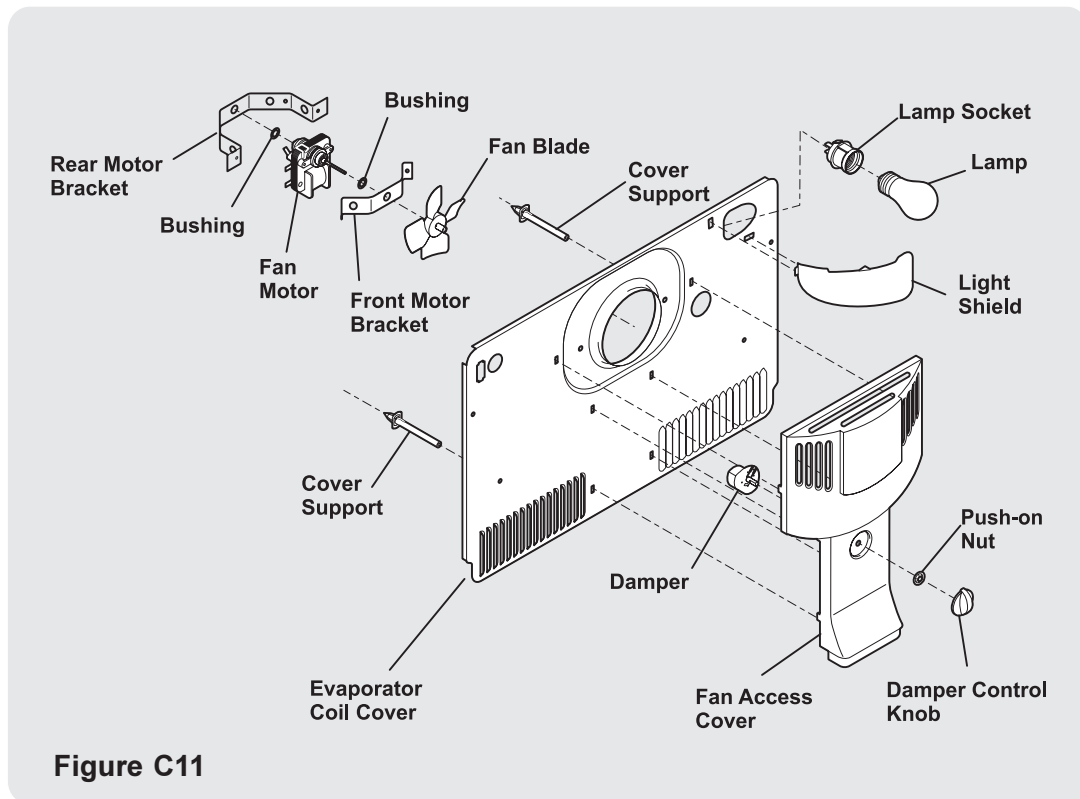

Figure C11

DEFROST TIMER (MECHANICAL)

The timer motor is energized during the defrost and compressor run cycles. The timer motor turns an internal cam. The cam opens and closes the electrical circuits to the compressor, evaporator fan motor, condenser fan motor, and defrost heater.

To Remove Defrost Timer

1. Disconnect electrical supply to refrigerator.
2. Remove four screws securing housing to top of refrigerator compartment.
3. Unplug molex connector coming from top of cabinet.
4. Unplug connector to Defrost Timer. It may be very snug. Use pliers to pull it loose from timer.
5. Remove two screws securing timer to control housing. (See Figure C12.)
6. Reverse procedure to complete repairs.

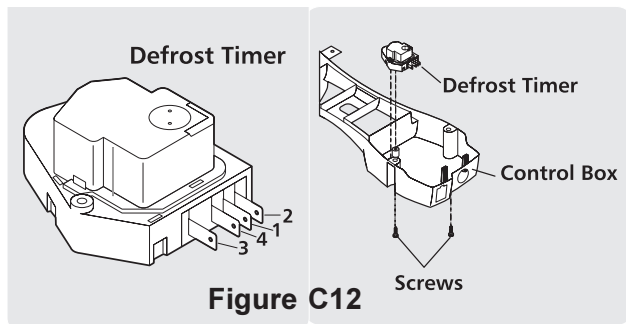

To Check Defrost Timer

NOTE: The Defrost Timer contains a capacitor in series with the motor. Use a 10K ohm scale and test as a capacitor.

1. Disconnect electrical supply to refrigerator.
2. Remove defrost timer.
3. With timer in compressor run cycle, check continuity from terminals 1 and 4.
4. Rotate timer knob until a click is heard or infinite resistance is present.
5. With timer in defrost cycle, continuity should be present between terminals 1 and 2.
6. With ohmmeter, check resistance at, or between terminals 1 and 3. (Refer to data sheet.)

To check the mechanical operation, connect the timer to the multiconnector. With 120 VAC present at terminals 1 and 3, the timer knob will rotate (check after ten minutes).

DEFROST THERMOSTAT

The defrost thermostat is a temperature sensing device. Wired in series with the defrost timer and the evaporator defrost heater, it senses the rise in evaporator temperature during a defrost cycle and cycles the defrost heater off after all frost is melted. It is calibrated

to permit a defrost cycle only when the temperature is below a preset temperature. The contacts in the defrost thermostat are set to open at 47°F and close at 25°F.

To Remove The Defrost Thermostat

1. Disconnect electrical supply to refrigerator.
2. Remove freezer shelves, ice bucket, ice trays and baskets.
3. Remove Ice Maker/Ice Maker tray holder (2 screws) in place on left wall of freezer.
4. Remove evaporator fan access cover (1 screw).
5. Remove evaporator coil cover (4 screws).

NOTE: Ensure that you disconnect the green ground wire connected to the evaporator coil cover on the bottom left hand corner.

6. Disconnect two leads to thermostat which is mounted to upper left corner of evaporator.
7. Remove thermostat from evaporator.
8. Reverse procedure to complete repairs.

To Test The Defrost Thermostat

1. Measure resistance across two thermostat leads. At room temperature, resistance should be infinity. Contacts are open.
2. Place couple of ice cubes on sides of thermostat. After few seconds, thermostat should reset.
3. Measure resistance again. This time, reading should be 0. Contacts have closed.
4. If you get resistance readings that differ from those listed in this procedure, replace defrost thermostat. Contacts are probably burnt.

DEFROST HEATER

The defrost heater is a radiant “U” shaped resistance heater, rated at 600 watts on some models. (See the Service Data Sheet for correct wattage.) The defrost heater is wired in series with the defrost thermostat and contacts 2 to 1 of the defrost timer. The defrost heater is energized during that period of the cycle when the defrost thermostat contacts are closed.

The length of time the heater is energized depends on the amount of frost accumulation on the evaporator.

NOTE: During the automatic defrost cycle, there will be a red glow in the vents on the back wall of the freezer compartment. This is normal during the defrost cycle.

How To Remove The Defrost Heater (See Figure C13)

1. Disconnect electrical supply to refrigerator.
2. Remove freezer shelves, ice bucket, ice trays and baskets.
3. Remove Ice Maker/Ice Maker tray holder (2 screws) in place on left wall of freezer.

4. Remove evaporator fan access cover (1 screw)

5. Remove evaporator coil cover (4 screws).

NOTE: Ensure that you disconnect the Green/
Yellow ground wire connected to the drain trough.

6. Disconnect leads (2) to defrost heater.

7. Pull evaporator away from insulator so bottom of evaporator is free and pointing towards you.

NOTE: The defrost heater is positioned in between the evaporator coils. It is a very snug fit.

8. Grab heater from bottom and pull free of evaporator. It is very snug so you will need to use a little force.

9. Check resistance of defrost heater using multimeter. (Refer to data sheet on page 65.)

10. Replace defrost heater if resistance readings are out of range.

11. Reassemble in reverse order.

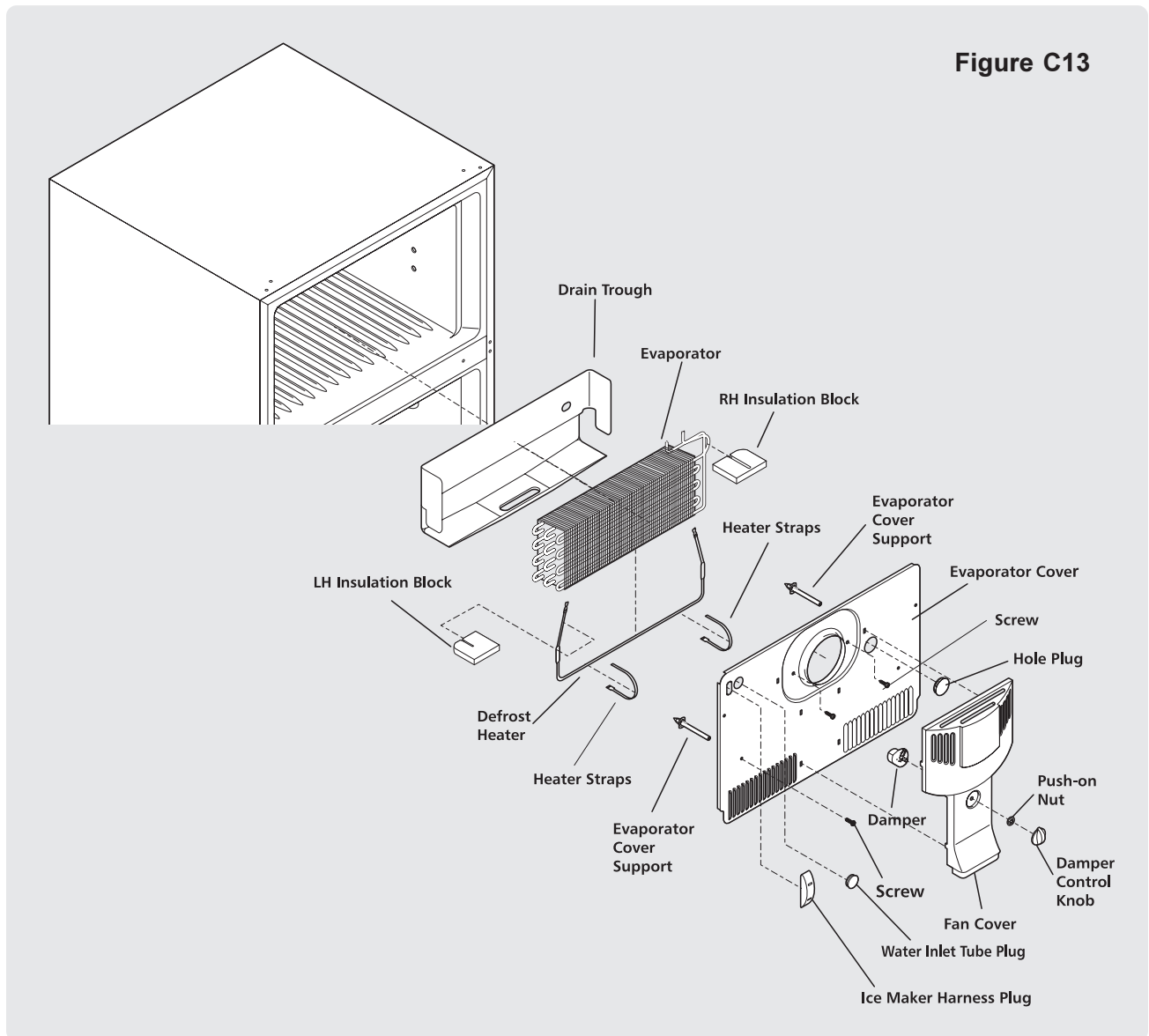

Figure C13

ADAPTIVE DEFROST CONTROL (ADC)

Electrical Requirements

Input Voltage:

- Voltage between L1 (Black) and Neutral (Light Blue) connector on the PC Board shall be 115 VAC \pm 10%, 60 Hertz.
- Cold Control (Orange) supplies line voltage to the ADC relay center contact.
- Defrost termination (Blue) sensing is between the defrost heater and the bimetal thermostat. The heater is on the hot side of the line and the bimetal thermostat on the neutral.
- Door Switch (Yellow/Red) sensing is between the door switch and the light bulb. (Yel/Blk on the PC Board)

Output Voltage:

- Output voltage to the defrost heater (Brown) and compressor (Red) is equal to the input voltage from the cold control (Orange).

The PC Board will withstand the following electrical loads for temperatures as high as 110°F.

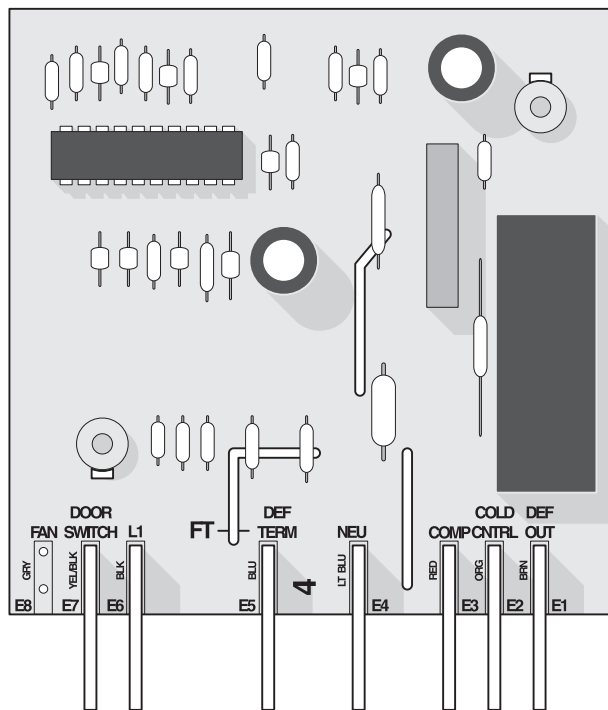

Amps	Duration Of Load	Reason For Load
15	3 Seconds	Locked Rotor
5	30 Minutes	Defrost Heater
3	Indefinite	Compressor Running

The ADC will dissipate an average of no more than 0.4 watts. The normal operating life is 22,000 defrost cycles over a 15 year period.

Initial Start & Power Interruptions

When power is applied to the power cord:

- If the defrost termination thermostat is closed, a cycle will be initiated after 1 hour.
- If the defrost termination thermostat is open, a compressor cycle starts immediately.

ADC Characteristics

The ADC has a base defrost interval of 6 hours of run time. All defrost interval timing starts with the compressor pull-down after a defrost or initial cabinet power.

When time for a defrost:

- If the compressor has been running equal to or more than 1 hour, defrost immediately.
- If the compressor continues to run less than 1 hour, initiate the defrost immediately after that 1 hour.
- If compressor continues to run for 1 hour after time for defrost, initiate the defrost immediately after that 1 hour.

The adaptive defrost logic operates as follows:

Defrost Time	Change In Defrost Interval	Defrost Interval
\leq (T range, min)	+2 Hours	Max 12 Hours
$>$ (T range, min) & \leq (T range, max)	No Change	
$>$ (T range, max)	-2 Hours	Min 6 Hours

The maximum defrost cycle must be terminated after 24 minutes. After each defrost heater termination, there must be a 6 minute delay before the compressor starts, but there is no time delay when the defrost heater has been on for 24 minutes.

Vacation Mode

When the defrost interval has reached 12 hours and the door has not been opened in the last 24 hours, the ADC places the refrigeration unit in vacation mode. Once in vacation mode, the defrost heater will be turned on after 72 hours. If the door has not been opened and the heater ON time is less than 16 minutes, then the defrost heater is turned on after 72 hours. Should the door not be opened but the heater runs for longer than 16 minutes, then the algorithm restarts in 6 hours. Once the refrigeration unit has been placed in vacation mode, if the door is opened and the compressor run time since the last defrost has been at least 5 hours, a defrost is initiated after 1 hour compressor run time since the initial door opening.

Defrost Parameter Values	
X initial	6 hours (min. defrost interval)
X max	12 hours (max. defrost interval)
X max,v	72 hours (max. defrost interval during vacation mode)
T range, min	12 minutes (min. heater on time for an "ideal" defrost)
T range, max	16 minutes (max. heater on time for an "ideal" defrost)

The maximum defrost cycle must be terminated after 24 minutes. After each defrost heater termination, there must be a 6 minute delay before compressor start except no time delay when the defrost heater has been on for 24 minutes.

System Diagnostics

An electrical connection between the light switch and refrigerator light bulb is coupled to the ADC system board, providing a manual method of initiating defrost and back to compressor. The actuation code will be a minimum of five depressions of the light switch within a six second time period.

- If a defrost is initiated manually and the termination thermostat is closed, the heater will be actuated until the termination thermostat opens. A six minute drip time follows before actuating the compressor and setting $x = (x_{\text{initial}})$.
- If a defrost is initiated manually and the termination thermostat is open, a six minute drip time is initiated before actuating the compressor and setting $x = (x_{\text{initial}})$.
- When terminating the defrost manually and the termination thermostat is closed or open, the compressor is actuated and sets $x = (x_{\text{initial}})$.

An electrical connection between the defrost heater and defrost termination thermostat is coupled to the ADC for system data, but also gives the technician the ability to check electrical continuity individually of either the defrost heater or termination thermostat from the ADC mounting area.

The ADC printed circuit board has component identification and lead wire color (name) adjacent to each electrical tab. Four of the tab terminals mate with the present defrost timer connection and the remaining three individual leads have matching color screening on the circuit board around the tab.

SECTION D - AIR CIRCULATION

AUTOMATIC DEFROST MODELS

Principals Of Automatic Defrost Operation

Automatic defrost refrigerators operate on the principle that moisture or frost transfers or migrates to the coldest surfaces (evaporator) in the freezer compartment. For example, a small amount of water spilled from an ice cube tray in the freezer compartment will freeze immediately. However, this ice in time will evaporate and transfer to the colder surfaces of the freezer evaporator coil.

Air Circulation Patterns

Automatic defrost models have a single evaporator in the freezer compartment, and have forced air cooling in the freezer and refrigerator compartments.

The “fin and tube” aluminum type evaporator is located on the back wall of the freezer compartment. A circulating fan (suction type) pulls air from the air return in the freezer and refrigerator compartments up through the evaporator surfaces from the bottom. The cold air is forced into a fan cover and discharged into the freezer and refrigerator compartments as shown in Figure D1.

Cold air for the refrigerator compartment flows from the evaporator through an air duct located in front of the evaporator cover and into the food compartment through air ducts on the Control Box. Return air from the refrigerator compartment flows through an opening on each side of the control housing, located all the way to the back next to the liner, through a 90° air return duct and back to the evaporator.

Cold air for the freezer compartment flows from the evaporator through an air discharge grill around the fan motor and into the freezer compartment. Return air from the freezer compartment flows through the louvers located on the back wall near the bottom of the freezer compartment, just in front of the evaporator.

The air circulating fan operates only when the compressor is running. During the defrost period, the compressor and circulating fan do not operate. The automatic defrost timer opens the electrical circuit to the fan motor and compressor.

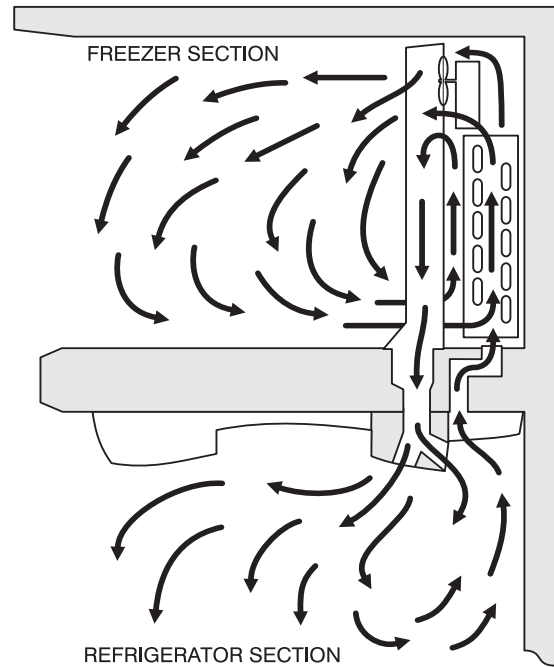

Figure D1

SECTION E - REFRIGERATION SYSTEM

NOTICE: Instructions given here are furnished as a guide. Persons attempting to use these instructions to make repairs to the sealed refrigeration system should have a working knowledge of refrigeration and previous training on sealed system repair, and an EPA certification for servicing refrigeration systems.

IMPORTANT NOTICE

Effective July 1, 1992, the United States clean air act governs the disposal of refrigerants such as R-134a. Therefore, when discharging or purging the sealed system, use an EPA approved refrigerant recovery system as outlined in the final rule on the protection of stratospheric ozone and refrigerant recycling which was published in the Federal Register May 14, 1993.

NOTE: Frigidaire does not permit the use of recovered refrigerant in the servicing of our products for in-warranty and out-of-warranty repairs or for products covered by service contracts. Therefore, only new refrigerant or refrigerant that has been reclaimed back to new specifications by a refrigerant manufacturer is to be used.

DEFINITIONS

Recovery:

To remove refrigerant in any condition from a system and store it in an external container without necessarily testing or processing it in any way.

Recycling:

To clean refrigerant for reuse by oil separation and single or multiple passes through devices, such as replaceable core filter-driers, which reduce moisture, acidity and particulate matter. This term usually applies to procedures implemented at the field job site or at a local service shop.

Reclaim:

To reprocess refrigerant to new product specifications by means which may include distillation. Will require chemical analysis of the refrigerant to determine that appropriate product specifications are met. This term usually implies the use of processes or procedures available only at a reprocessing or manufacturing facility.

SAFETY WARNINGS

Compressor Testing

Whenever testing a compressor, extreme caution should be used to prevent damaging the terminals. A compressor with a damaged terminal or a grounded winding can expel a terminal from its insulated housing when the compressor is energized. If this happens, a mixture of refrigerant and oil will be released that could be ignited by an external heat source (open flame, heater, etc.). Also, if there is air in the system when this happens, a spark at the compressor shell could ignite the refrigerant and oil mixture.

Charging Sealed Systems

Overcharging a refrigeration system with refrigerant can be dangerous. If the overcharge is sufficient to immerse the major parts of the motor and compressor in liquid refrigerant, a situation has been created which, when followed by a sequence of circumstances, can lead to the compressor shell seam separating.

A hydraulic block occurs, preventing the compressor from starting. This condition is known as locked rotor. Electric current continues to flow through the compressor motor windings which become, in effect, electric resistance heaters. The heat produced begins to vaporize the excess refrigerant liquid, causing a rapid increase in system pressure. If the compressor protective devices fail, the pressure within the system may rise to extremes far in excess of the design limits. Under these conditions, the weld seam around the compressor shell can separate with explosive force, spewing oil and refrigerant vapor which could ignite.

To eliminate this exceedingly rare but potential hazard, never add refrigerant to a sealed system. If refrigerant is required, evacuate the existing charge and recharge with the correct measured amount of the refrigerant specified for the system.

SOLDERING

WARNING: WEAR APPROVED SAFETY GLASSES WHEN WORKING WITH OR ON ANY PRESSURIZED SYSTEM OR EQUIPMENT. HAVE AN APPROVED DRY TYPE FIRE EXTINGUISHER HANDY WHEN USING ANY TYPE OF GAS OPERATED TORCH.

1. All joints to be soldered must have proper fit. Clearance between tubes to be soldered should be from .001" to .006". It is not practical to actually measure this; however, you do not want a dry fit or loose fit. Tubing joints should overlap about the distance of their diameter except for restrictor tubes, which should be inserted 1.25"
2. Clean all joint areas with fine steel wool or, preferably, an abrasive cloth, such as grit cloth No. 23 or Scotch-Brite.
3. Apply thin film of liquid flux recommended for silver soldering to surfaces to be joined, and to surfaces immediately adjacent to joint.
4. Align tubing so no stress is on joint. Do not move tubing while solder is solidifying or leaks will result.

CAUTION: During application of heat, use wet cloths to prevent heat from conducting to areas other than soldered joint. Use a sheet of metal as a heat deflector to keep flame away from inflammable materials and painted surfaces.

5. Use a torch of adequate capacity so joint can be quickly heated with a minimum of heat travel to other points. Use a good grade of silver solder.
6. Solder connections. If tubing is properly cleaned and fluxed, solder will flow readily. Use only enough solder to make a good bond.
7. Allow joint to cool, then wash exterior with water to remove flux.

BASIC COMPONENTS

The basic components of a refrigerator are a compressor, condenser, evaporator, heat exchanger (capillary tube and suction line), drier, and perimeter hot tube.

PERIMETER HOT TUBE

To reduce the possibility of condensation forming on the exterior of the cabinet in high humidity areas, a perimeter hot tube (refrigerant tube) has been installed in the unit. The perimeter tube extends up the left side, across the center mullion and down the right side and into the filter drier. When the compressor operates, warm refrigerant flows through the primary condenser, then, into the primary hot tube, warming the cabinet front exterior.

The perimeter hot tube is not replaceable. In the unlikely event of a leak in the hot tube, a kit is available to bypass the hot tube in the sealed system. An electrical heater wire must be installed within the tubing. Refer to the appropriate parts list of the model being serviced for the correct kit part number. See the procedure at the end of this section to install an electric heater.

REFRIGERANT CYCLE

The refrigerant cycle is a continuous cycle that occurs whenever the compressor is in operation. Liquid refrigerant is evaporated in the evaporator by the heat that enters the cabinet through the insulated walls, and by the heat from product load and door openings. The refrigerant vapor is then drawn from the evaporator, through the suction line, to the compressor. Compression raises the pressure and temperature of the vapor in the compressor, and the vapor is then forced through the discharge valve into the discharge line and into the condenser. Air passing over the condenser surface removes heat from the high pressure vapor which then condenses to a liquid. The liquid refrigerant then flows from the condenser to the evaporator, through the small diameter liquid line (capillary tube). Before it enters the evaporator, the liquid refrigerant is sub-cooled in the heat exchanger by the low temperature suction vapor in the suction line.

LOW OR HIGH-SIDE LEAK OR UNDERCHARGE

A loss of refrigerant can result in any of the following:

1. Excessive or continuous compressor operation.
2. Above normal freezer compartment temperature.
3. A partially frosted evaporator (depending on amount of refrigerant loss).
4. Below normal freezer compartment temperature.
5. Low suction pressure (vacuum).
6. Low wattage.

The condenser will be "warm to cool", depending on the amount of refrigerant lost.

When refrigerant is added, the frost pattern will improve, the suction and discharge pressures will rise, the condenser will become hot and the wattage will increase.

In the case of a low side refrigerant leak, resulting in complete loss of refrigerant, the compressor will run, but will not refrigerate. Suction pressure will drop below atmospheric pressure and air and moisture will be drawn into the system, saturating the filter drier.

If a slight undercharge of refrigerant is indicated, and no leak can be found after a thorough leak test, the charge can be corrected without changing the compressor.

If there is reason to believe the system has operated for a considerable length of time with no refrigerant, and the leak occurred in the evaporator, excessive amounts of

moisture may have entered the system. In such cases, the compressor may need to be replaced to prevent repetitive service.

If a high-side leak is located and some refrigerant remains in the system, it is not necessary to change the compressor.

TESTING FOR REFRIGERANT LEAKS

If the system is diagnosed as short of refrigerant and the system has not been recently opened, there is probably a leak in the system. Adding refrigerant without first locating and repairing the leak, or replacing the component, will not permanently correct the difficulty. **The leak must be found.** Sufficient refrigerant may have escaped to make it impossible to leak test effectively. In such cases, add a 1/4" line piercing valve to the compressor process tube. Add sufficient refrigerant vapor to increase the pressure to 40 to 50 lb. per sq. in. Check the low side for leaks. Run the compressor 2 or 3 minutes and check the high side for leaks. Recover refrigerant using an EPA approved recovery system.

NOTE: The line piercing valve (clamp-on type) should be used for test purposes only. It must be removed from system after it has served its purpose.

CHECKING FOR INTERNAL (HOT TUBE) LEAKS

Before checking for internal leaks, check all accessible system components and joints for leaks.

If an internal hot tube leak is suspected, it must be confirmed. Use the following procedure:

1. Recover refrigerant by using EPA approved recovery system.
2. After *system refrigerant* is completely recovered, disconnect drier from hot tube. Pinch off and solder end of hot tube closed.
3. Cut line from condenser to hot tube and solder a 1/4" charging hose fitting to open end of hot tube or put compressor fitting on tube.
4. Connect pressure gauge and access valve to hot tube, and pressurize to 250 psig using dry nitrogen or carbon dioxide.

WARNING: NEVER PRESSURIZE WITH OXYGEN. NEVER OPEN A HIGH PRESSURE TANK UNLESS IT IS EQUIPPED WITH A PRESSURE REGULATOR. NEVER PUT HIGH PRESSURE ON DOME OF COMPRESSOR—IT COULD EXPLODE. MAKE SURE GAUGE FITTINGS ARE IN GOOD CONDITION AND DO NOT LEAK.

5. Leave pressure on hot tube for 24 hours. Any drop in pressure is indication of leak.

If dry nitrogen or carbon dioxide is not available, follow steps 1 through 3 above, then steps 4 and 5 below:

4. Connect gauges to charging hose fittings. Pull vacuum on hot tube.
5. Leave vacuum on each side of system for 24 hours. Any loss of vacuum indicates leak.

COMPRESSOR REPLACEMENT

CAUTION: NEVER install a new compressor without first checking for possible system contamination.

To check for contamination, obtain oil sample from old compressor.

- If the oil has burned odor, but no color change or residue — follow instructions in section "*Installing A New Compressor* on page 29".
- If oil has a burned sugar odor and shows contamination (dark color) — follow instructions in next section, *To Flush The System*. Remove as much of contamination as possible from system before installing new compressor and filter-drier.

To Flush The System

NOTE: It is recommended that system be flushed with dry nitrogen. However, if refrigerant is used to flush system, you must look at the serial plate to see what type of refrigerant is used in the system. This is the only refrigerant that can be used to flush the system and it must be recovered.

CAUTION: Use extreme care when using dry nitrogen to flush systems. Pressure in nitrogen cylinder could be as high as 2000 psi. Nitrogen cylinder must be equipped with approved pressure regulator and pressure relief valve. Ensure that your hoses have adequate ratings for pressure involved, and that all of your equipment is in good condition.

CAUTION: The end of flushing hose off tank regulator must be equipped with a hand shut-off valve (Robinair No. 40380). Close hand shut-off valve and adjust nitrogen regulator to correct pressure before proceeding with flushing procedure.

To Use Dry Nitrogen To Flush The System:

1. Remove compressor and filter-drier. Connect process coupling to outlet tube of condenser.
2. Fasten cloth over other end of coil to prevent old oil from spraying over room.

3. Connect hand shut-off valve on flushing hose to process coupling.
4. Slowly open hand shut-off valve and allow nitrogen to flow through condenser until discharge is clear.

CAUTION: DO NOT exceed 300 PSIG.

5. Disconnect cap tube from evaporator. Flush evaporator in same manner as condenser.

CAUTION: DO NOT exceed 150 PSIG.

6. Flush cap tube. This is only possible if you have proper service valve adaptor.

CAUTION: DO NOT exceed 300 PSIG.

7. Reassemble system.

To Use Refrigerant To Flush The System:

CAUTION: Refrigerant used for flushing must be recovered into a recovery bag. Meter amount of refrigerant used for flushing with your charging cylinder. DO NOT OVERFILL THE BAG.

1. Disconnect the suction and discharge lines from the compressor and remove the filter-drier. Connect process coupling to outlet and inlet tube of condenser.
2. Connect hose to outlet process coupling and charging cylinder. Connect another hose to inlet coupling and recovery bag.
3. Open charging cylinder and allow refrigerant to flow through condenser until discharge into bag is clear.

NOTE: To flush evaporator and heat exchanger you must remove evaporator from inside product to disconnect cap tube.

4. Disconnect capillary tube from evaporator. Flush evaporator in same manner as condenser.
5. Flush cap tube. This is only possible if you have proper service valve adaptor.
6. Reassemble system.

Installing a New Compressor

NOTE: Entirely new compressors have been developed for use with R-134a and Ester oil refrigeration systems. Both compressor and electric motor have been modified. Old compressors intended for R-12 refrigerant must not be used for new systems charged with R-134a.

Replacement of compressor and installation of filter-drier must be done in continuous sequence so system is exposed to atmosphere no longer than necessary.

All replacement compressors are shipped with rubber plugs in the suction, discharge, and process tubes and contain the

correct oil charge and a holding charge of inert gas. Compressors have a low-side process tube attached to the compressor shell. A high-side process tube is attached to the filter-drier.

WARNING: DO NOT OPERATE RECIPROCATING COMPRESSOR WHEN CHARGING LIQUID REFRIGERANT INTO SYSTEM THROUGH ITS PROCESS TUBE.

Replacement compressors for refrigerators and food freezers may have an oil cooler even if the original compressor did not. If the product is not equipped for an oil cooler, leave the plastic caps in place and install the compressor, connecting only to the suction and discharge lines of the new compressor.

Before installing the replacement compressor, remove the discharge plug and check for the pop sound of the inert gas leaving the compressor.

CAUTION: DO NOT use compressor if you do not hear this sound.

If the compressor checks OK, reinstall the plug. Do not remove any of the plugs again until the compressor is in position and you are ready to braze the lines.

CAUTION: On R-134a systems, compressor must NOT be left open to atmosphere for more than 10 minutes to prevent moisture contamination of oil.

A new compressor which is cold (e.g. after having been kept in a cold service van) should be left to warm to the surrounding temperature before the plugs on the compressor connections are removed. This will help prevent condensation from forming in the oil and the compressor. Also, avoid opening the system when any of the components or lines are cold.

NOTE: Release holding charge (release slowly to avoid oil discharge) on new compressor to ensure that there is no leak in seam or tubing. Then, reinstall rubber plug.

1. Disconnect electrical supply to refrigerator.
2. Remove compressor access panel.
3. Remove rail and condenser fan shroud screws.
4. Remove fan motor harness clamp located below heat exchanger wiring harness cover.
5. Disconnect condenser fan motor multiconnector.
6. Pull compressor assembly straight out (See Figure E1).
7. Recover refrigerant by using EPA approved recovery system.
8. Remove leads from compressor motor terminals.
9. Remove mounting clips and washers.
10. After refrigerant is completely recovered, cut suction and discharge lines as close to compressor as possible. Leave only enough tubing to pinch off and seal defective compressor. Plug or tape any open system tubing to avoid entrance of moisture and air into system. Remove inoperable compressor and transfer mounting parts to new compressor.

11. Install new compressor in exact same manner as original compressor.
12. Reform both suction and discharge lines to align with new compressor. If they are too short, use additional lengths of tubing. Joints should overlap 0.5" to provide sufficient area for good solder joint. Clean and mark area where tubing should be cut. Cut tubing with tubing cutter. Work as quickly as possible to avoid letting moisture and air into system.

NOTE: If low-side process tube is too short, silver solder four inch piece of tubing onto process tube at this time.

13. Solder all connections according to soldering procedure outlined above.
14. Remove original filter-drier.

CAUTION: DO NOT unbraze old filter-drier from system. This will vaporize and drive moisture from desiccant back into system. The old filter-drier should be cut out of system.

15. Install new filter-drier at condenser outlet.
16. Evacuate and charge system using recommended procedure described under *Evacuating and Recharging* on pages 36-37.
17. Reconnect compressor terminal leads in accordance with refrigerator wiring diagram.
18. Reassemble unit.

Figure E1

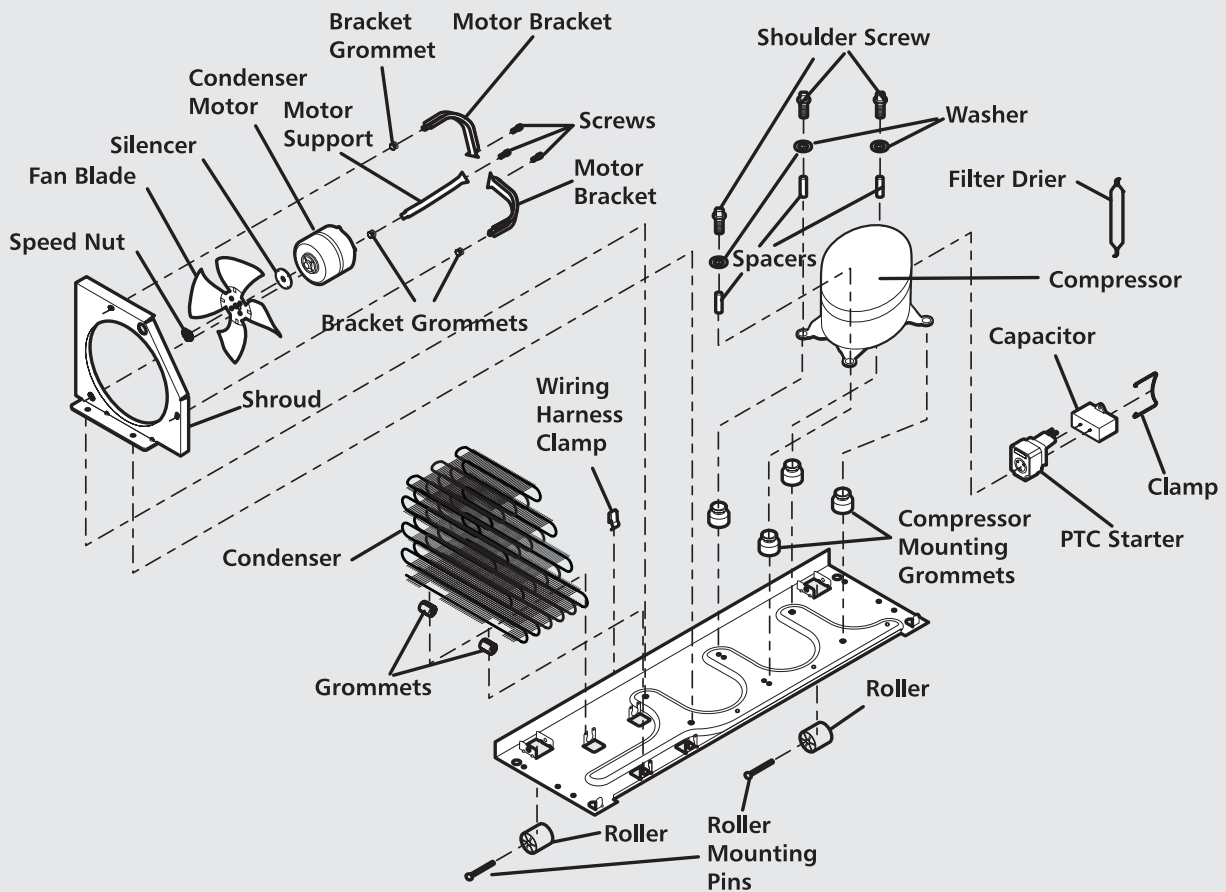

EVAPORATOR REPLACEMENT

CAUTION: Remove any component part from the interior of the cabinet before attempting to solder. The excessive heat from soldering will warp the plastic liner.

The evaporator is located in the upper section of the freezer and is secured to the drain pan by top and bottom brackets. Styrofoam blocks are located on each side, directly across from each other, to ensure proper air flow through the evaporator.

The heat exchanger on this style of refrigerator is in the insulation between the back of the food liner and the back of the cabinet. Because of this, you will not be able to remove the heat exchanger with the evaporator. You will make your line welds inside the freezer compartment. The kit contains a heat shield to protect the liner from damage when making your line welds.

This kit contains:

1 Evaporator	1 Heat shield
1 Drier-Filter	1 Instruction Sheet

1. Disconnect electrical supply to refrigerator.
2. Remove all freezer section shelves and baskets.
3. Recover refrigerant using EPA approved recovery system.
4. Remove evaporator coil cover.
5. Cut suction line between weld and evaporator. Using file, score and break cap tube just above weld. (See Figure 1.)



To replace evaporator, cut suction line at this point.

FIGURE 1

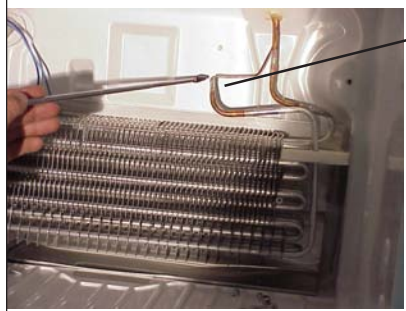

Cut cap tube at this point.

6. Disconnect limiter and defrost heater.
7. Clean end of suction line and cap tube. Straighten and slightly bend toward front of cabinet.
8. Cut small "X" in heat shield and slide cap tube and suction line through hole. Pack heat shield in top corner of liner. (See Figure 2.) You may want to use small pair of vise-grips on suction line to help hold heat shield in place.



Cut small hole in middle of the shield.

FIGURE 2



Place shield over heat exchanger and push into top corner of liner.

9. Install defrost heater in new evaporator and set inside freezer. Do not push all the way in place. Sit evaporator 2 to 3 inches out from liner. This will allow additional room for welding. (See Figure 3.)

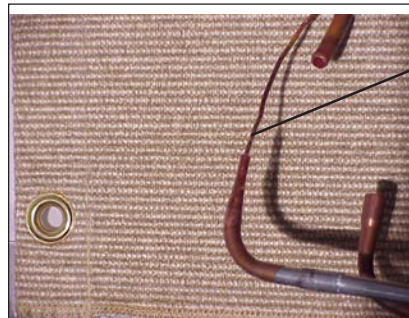

Make your weld on cap tube first.

FIGURE 3

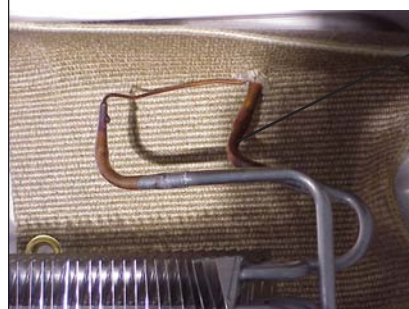

Now make your weld on suction line.

10. Place cap tube in new evaporator and weld in place. Put suction line in new evaporator and weld in place. (See Figure 3.)
11. Using sharp knife, cut along a seam on heat shield, from hole for lines to right edge of shield. Slide shield off suction line assembly.
12. Push evaporator back in place and connect heater. Mount limiter on evaporator.
13. Replace Drier-Filter. Pump down and recharge system.
14. Allow product to run and make sure refrigerant is circulating.
15. Reinstall evaporator cover and compartment cover, if so equipped.

HEAT EXCHANGER KIT REPLACEMENT

The original heat exchanger (Suction Line & Cap Tube Assembly) in this refrigerator is enclosed in the insulation between the liner and the cabinet at the back. Because of this, you can not remove the original part. It will be necessary to run a new heat exchanger down the back of the refrigerator and bypass the internal heat exchanger.

This kit contains:

1 Heat Exchanger	12 Screws
1 Drier-Filter	1 Cover, Upper
1 Armor Flex	1 Cover, Lower
2 Tape	1 Package Permagum
1 Instruction Sheet	

To replace the Heat Exchanger:

1. Recover refrigerant from sealed system.
2. Remove evaporator cover and disconnect defrost heater and limit thermostat wires.
3. Cut heat exchanger off flush with liner. (See Figure 1.)

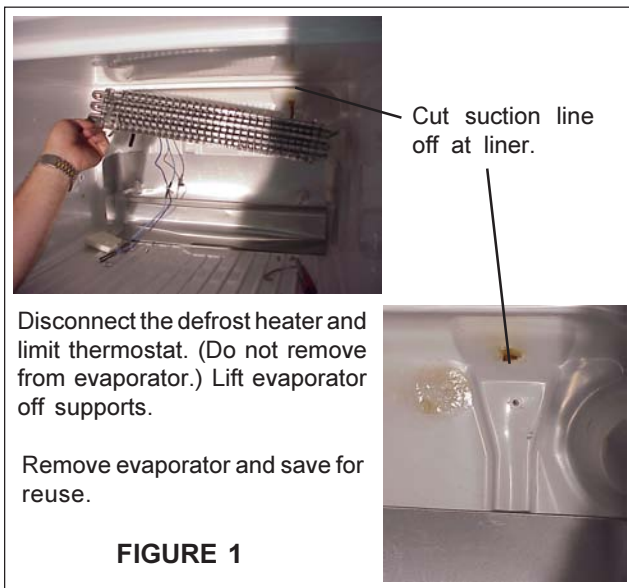

4. Recover evaporator. (You do not need to remove defrost heater.)
5. Using ¼ drill bit, drill hole through the cabinet from inside at location shown in Figure 2.
6. Using ½” drill bit, open hole drilled in Step 5 to ½” from back of product. See Figure 2.

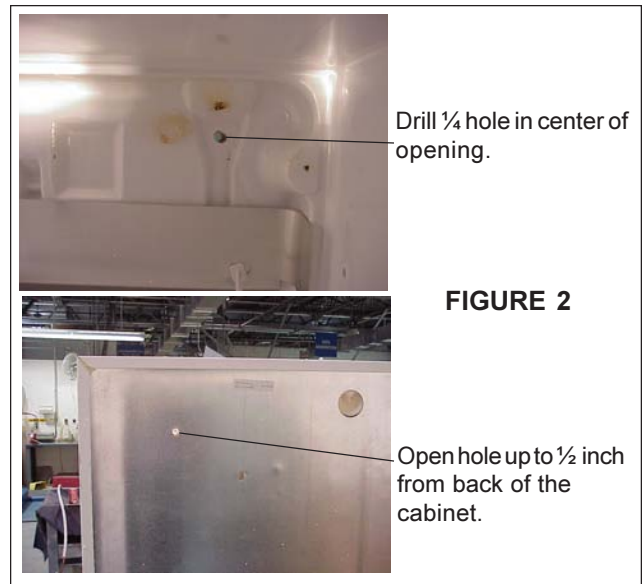

7. Remove stubs of old heat exchanger from evaporator and install new heat exchanger into evaporator.
8. Push heat exchanger through hole in cabinet (see Figure 3) and set evaporator in place.
9. Excess cap tube can be folded from bottom so it is alongside suction line and will be inside Armor Flex. Slide Armor Flex over line covering excess cap tube until cover is against hole at back of cabinet. (See Figure 3.)

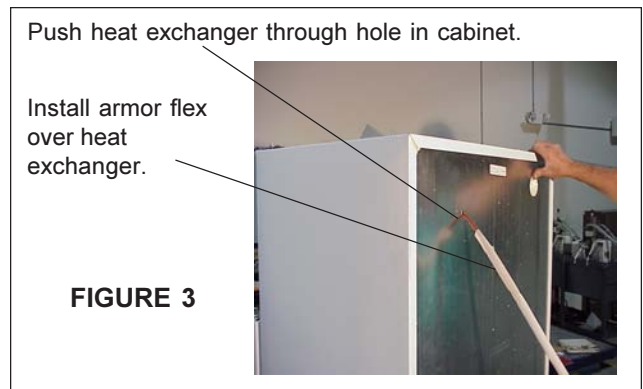

10. Seal hole on inside and outside using Permagum in the kit.
11. The two piece cover can now be installed to cover heat exchanger. One cover is closed on one end. This is top section and will be installed last. Using section that is open on both ends, set it even with bottom of compressor compartment opening. Using screws provided with kit, screw cover to back of cabinet. Screws will cut their own holes so no predrilling is necessary. (See Figure 4.)

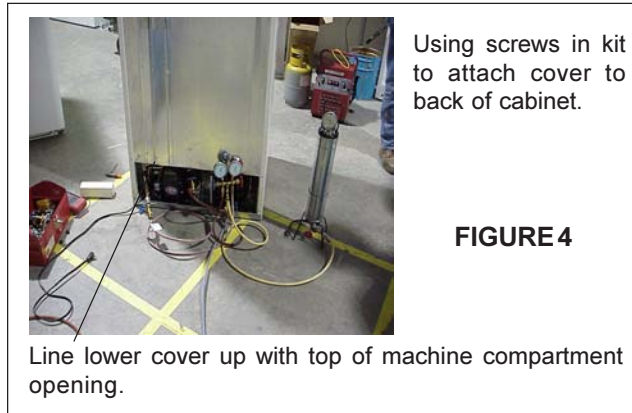

12. Upper section closed end should be installed at top against seam between painted cabinet and back galvanized part of cabinet. Bottom of cover will overlap lower section. Attach upper cover using remainder of screws.
13. Replace Drier-Filter. Pump down and recharge system.
14. Allow product to run and make sure refrigerant is circulating. Reinstall evaporator cover and compressor compartment cover.

PERIMETER HOT TUBE REPAIR KIT

Effective July 1, 1992, Section 608 of the **Clean Air Act** prohibits Individuals from knowingly venting ozone depleting compounds used as refrigerants into the atmosphere while maintaining, servicing, repairing, or disposing of refrigerant equipment.

A hot tube repair kit is used to bypass a leaking Perimeter Hot Tube (Yoder-Loop). The Perimeter Hot Tube must be cut out of the sealed refrigeration system and a low wattage heater wire installed inside the tube. This heater will prevent condensation from forming on the exterior front edge of the cabinet.

This kit contains:			
1	Copper Bypass Tube	1	Plastic Sleeve
1	Drier-Filter	1	Heater Wire
3	Clamps	1	Harness Adapter
3	Screws	2	Wire Connectors

BYPASSING PERIMETER HOT TUBE - STEP 1

1. Disconnect service cord from power supply.
2. Recover refrigerant from system.
3. Remove filter-dryer.
4. Using tubing cutter, cut and de-burr tubing from perimeter hot tube at points shown in figure below.

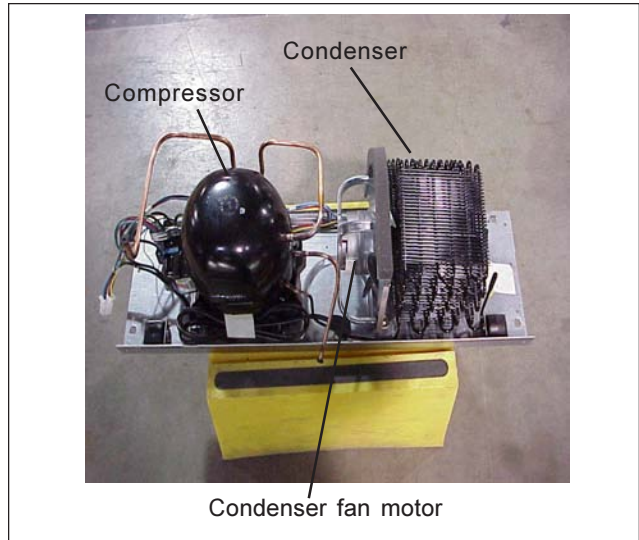

5. Install copper bypass tube and replacement filter-dryer as shown in figure below. Use 45% silver solder for all connections.

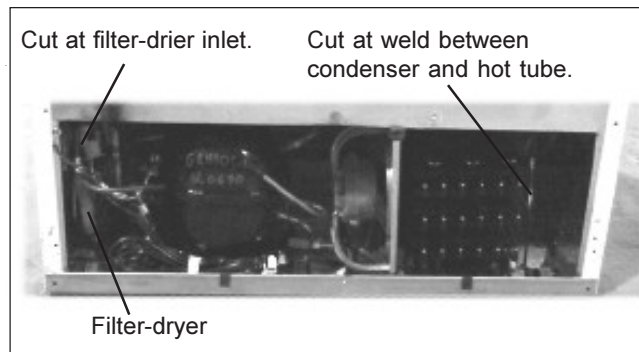

6. Drill or pierce three holes in cabinet to hold clamps. Secure by-pass tube just below cabinet edge with three clamps and screws provided.

NOTE: When clamped in place, the by-pass tube should NOT touch any plastic lines, like water lines for ice makers and/or filters, as well as drain lines.

7. Evacuate and recharge refrigeration system. Refer to serial plate for correct charge.

INSTALLING THE HEATER WIRE - STEP 2

1. Attach Vacuum Pump and Gauge Set to one end of Perimeter Hot Tube with an Adapter and Plastic Sleeve. See illustration on next page.
2. Cutoff waxed end of Fiberglass braid that is extended past end of heater wire and make knot in end just a little smaller than inside diameter of hot tube.
3. Insert knot on end of braid into open end of Perimeter Hot Tube.
4. With braid inserted, start Vacuum Pump and place your thumb over end of tube. When good vacuum is obtained, release your thumb and begin to feed braid into Hot tube. Continue this process until string reaches Plastic Sleeve.

NOTE: Take the time to remove all the bends from the heater (caused from being rolled up) by pulling the heater and braid through a shop rag with a small amount of silicone on the rag and laying it in a roll at the open end of the Hot Tube it will make heater installation go faster. Using of a good two stage, 5 CFM Vacuum Pump will also make heater installation go faster.

5. Disconnect Plastic Sleeve.
6. Pull braid out while pushing equal amount of braided heater into tube at other end until heater wire inside braid appears.

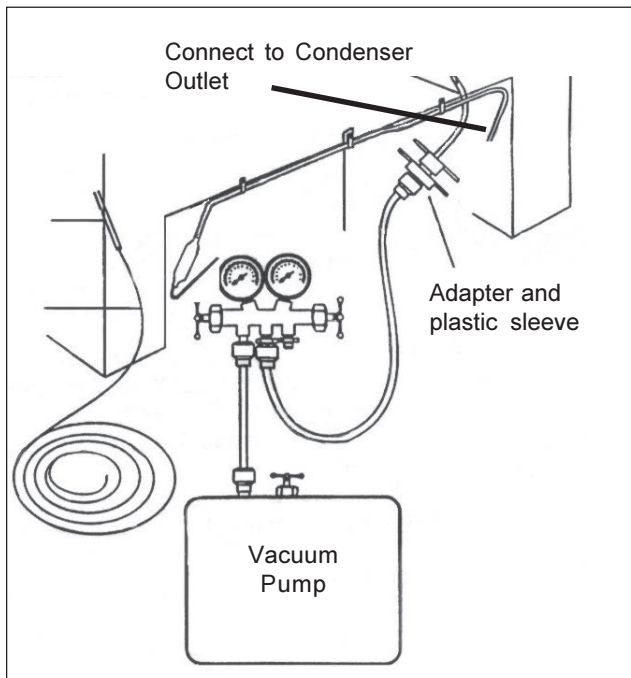

INSTALLING THE HEATER WIRE - STEP 3

1. Remove wires (with terminals) from compressor starter/overload. On some models you will need to depress locking tabs located in relay housing (See Drawing below.)

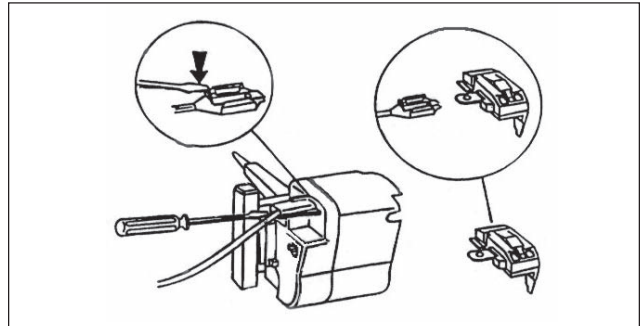

2. Install harness adapter into refrigerator circuit as shown below.

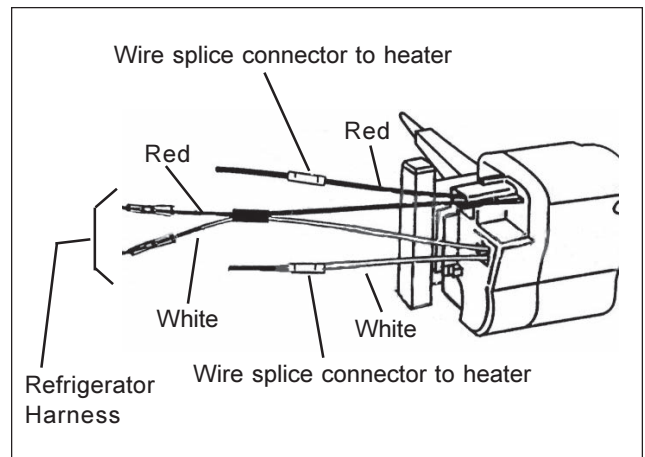

3. Cut off braid at start of heater. Strip insulation back about 5/16 inch. Be careful not to damage heater resistance wire. Splice heater wire ends to loose leads of adapter harness with furnished wire connectors.
4. Dress wires away from Condenser Fan Blade and any sharp edges.
5. Secure wires with electrical tape as necessary.
6. Reinstall Back Panel for proper air flow over condenser and compressor.

CONDENSER REPLACEMENT

1. Disconnect electrical supply to refrigerator.
2. Remove compressor access panel.
3. Remove rail and condenser fan shroud screws.
4. Remove fan motor harness clamp located below heat exchanger wiring harness cover.
5. Disconnect condenser fan motor multiconnector.
6. Pull compressor assembly straight out.
7. Recover refrigerant, using an EPA approved recovery system.

8. Remove wiring from compressor.
9. After refrigerant is completely recovered, disconnect suction and discharge lines from compressor.
10. Remove condenser mounting clips that secure drain pan and remove condenser.
11. Install replacement condenser.
12. Remove original filter-drier.

CAUTION: DO NOT unbrazed the old filter-drier from the system. This will vaporize and drive moisture from the desiccant back into the system. The old filter-drier should be cut out of the system.

13. Install new filter-drier at condenser outlet.
14. Evacuate and charge the system using recommended procedure described under *Evacuating and Recharging*.
15. Reassemble unit.

SUCTION LINE AND CAPILLARY TUBE REPLACEMENT

Follow the same procedure used for evaporator replacement.

FILTER-DRIER INSTALLATION

Any time the sealed system is opened and the refrigerant charge is removed, the liquid line filter-drier must be replaced and the system thoroughly evacuated before recharging.

CAUTION: DO NOT unbrazed the old filter-drier from the system. This will vaporize and drive moisture from the desiccant back into the system. The old filter-drier should be cut out of the system.

CAUTION: Use only a 15 gram XH9 liquid line filter-drier (part number 5303305677) when servicing refrigerator and freezer systems. This filter-drier is compatible with either R-12 or R-134a refrigerant.

1. Disconnect electrical supply to refrigerator.
2. Recover refrigerant by using EPA approved recovery system.
3. Using three cornered file, score groove around capillary tube as close to old filter-drier as possible. Break capillary tube along score mark from filter-drier.
4. Cut condenser outlet tube at filter-drier. Discard filter-drier.
5. Thoroughly clean condenser outlet tube and capillary tube.
6. Place inlet connection of filter-drier over condenser tube approximately $\frac{1}{4}$ " and solder.
7. Insert capillary tube input end into filter-drier outlet. Do not allow tube to bottom against screen. Solder

carefully so that solder does not plug capillary tube.

8. Install process tube adaptor to filter-drier.
9. Evacuate and charge system using recommended procedure described under *Evacuating and Recharging*.
10. Reassemble unit.

EVACUATING AND RECHARGING

CAUTION: Check the serial plate for the correct refrigerant type. It is extremely important to verify the type of refrigerant in the system before starting any sealed system repairs.

CAUTION: With the possible exception of the vacuum pump, all service equipment that comes in contact with R-134a during evacuation and recharging must be dedicated. Accordingly, R-134a will require a dedicated charging cylinder, manifold gauge set, process tube adaptors, and hoses. Any residual mineral oil on other tools (tubing cutter, etc.) must be thoroughly cleaned off before using on R-134a/Ester oil systems. It will be necessary to check with the manufacturer of your vacuum pump for refrigerant and oil compatibility issues.

CAUTION: If you use a vacuum pump with mineral oil to evacuate an R-134a system, it is ABSOLUTELY ESSENTIAL to have a shut-off valve between the pump and your manifold gauge set as shown in Figure E2. The hand valve must be closed during all times when the vacuum pump is not operating. This will prevent the migration of mineral oil vapor into the R134a/Ester oil system. If the vacuum pump should stop during evacuation for any reason, the hand pump shut-off valve must be closed immediately.

CAUTION: Ensure that your refrigeration hoses are specifically for use with R-134a refrigerant. Research has shown that compounds in standard refrigeration hoses may enter sealed systems and ultimately restrict the cap tube in an R-134a system.

Equipment Needed:

- Heated Dial-A-Charge charging cylinder
- Standard 3-port manifold gauge set:
 - 4 charging hoses
 - Tee fitting with valve core stem removed (Robinair No. 40396)
 - Hand shut-off valve (Robinair No.40380)
- Two stage vacuum pump

- Process tube adapter kit (Robinair No. 12458)
- Tubing cutter
- Pinch-off tool capable of making leak proof seal
- Complete brazing torch set
- Small 3-corner file
- Grit cloth or Scotch-Brite
- 45% silver solder and flux

Installing Evacuation and Recharging Equipment

1. Disconnect refrigerator from electrical supply.
2. If compressor was replaced, install correct size process tube adaptor on process tube. If compressor was not replaced, cut process tube with tubing cutter, leaving as much tube as possible, and install correct size process tube adaptor.
3. Install correct size process tube on high-side process tube.
4. Attach refrigeration service gauge manifold to system in following order:
 - Low-side (compound gauge) hose to suction side process tube adaptor.
 - High-side (pressure gauge) hose to high-side process tube adaptor.
 - Center port manifold hose before hand shut-off valve to charging cylinder.
 - Center port manifold hose after hand shut-off valve to vacuum pump.
4. Operate the vacuum pump for minimum of 30 minutes to attain minimum of 29.9" (500 micron) vacuum.
5. Close hand shut-off valve to vacuum pump. Watch compound gauge for several minutes. If reading rises, there is leak in system, go to step 6. If no leak is indicated, stop vacuum pump. System is now ready for charging.
6. If leak is indicated, stop vacuum pump and introduce small charge of refrigerant into system by cracking valve on bottom of charging cylinder until system is pressurized to 40 or 50 lbs, psig.
7. Leak test low-side. Close compound gauge. Run compressor for few minutes and leak test high-side. When leak is found, recapture refrigerant using EPA approved recovery system, repair and go back to step 1.

Evacuating System

WARNING: R134A SYSTEMS ARE PARTICULARLY SUSCEPTIBLE TO MOISTURE CONTAMINATION WHICH CAN ONLY BE PREVENTED BY EVACUATING THE SYSTEM FOR A MINIMUM OF 30 MINUTES TO ATTAIN A MINIMUM 29.9 INCH (500 MICRON OR LOWER) VACUUM.

To achieve the required levels of evacuation, a properly maintained two-stage vacuum pump in good condition is required. It is absolutely essential to maintain your vacuum pump according to the manufacturer's instructions including required oil changes at the recommended intervals. Vacuum pump oil should always be changed after evacuating a contaminated system.

Vacuum pump performance should be checked periodically with a micron gauge.

1. Make certain that charging cylinder valve, hand shut-off valve, and manifold gauge valves are closed.
2. Start vacuum pump.
3. Open hand shut-off valve and slowly open both manifold valves, turning counterclockwise, for two full rotations.

CAUTION: If high vacuum equipment is used, just crack both manifold valves for a few minutes, then open slowly for the two full turns, counterclockwise. This will prevent the compressor oil from foaming and being drawn into the vacuum pump.

Charging The System

CAUTION: Check the serial plate for the correct refrigerant type. It is extremely important to verify the type of refrigerant in the system before starting any sealed system repairs.

CAUTION: After charging the system with liquid, be certain to wait at least 5 minutes before starting the compressor to give the refrigerant a chance to disperse throughout the system. Otherwise, the compressor could be damaged by attempting to pump excessive quantities of liquid.

Preparing The Charging Cylinder:

1. Make certain that hand shut-off valve to vacuum pump is closed.
2. Close high-side manifold gauge valve.
3. Set charging cylinder scale to pressure indicated on cylinder pressure gauge.
4. Observe refrigerant level in sight glass. Subtract amount to be charged into system and note shut off point.
5. Open charging cylinder valve slowly and allow proper charge to enter system.
6. As soon as refrigerant in sight glass has gone down to predetermined level, close charging cylinder valve.

WARNING: DISCONNECT THE CHARGING CYLINDER HEATER AT THIS TIME TO PREVENT THE CYLINDER PRESSURE FROM EXCEEDING ITS MAXIMUM LIMITS.

7. Allow system to sit for five minutes.
8. Turn on refrigerator compressor. Run compressor for few minutes and monitor system pressures.
9. When satisfied that unit is operating correctly, clamp high-side process tube with pinchoff tool while unit is still running.
10. Slowly open high-side manifold gauge valve to allow compressor to remove any refrigerant trapped in high-side hose and process fitting.
11. Close both manifold gauge valves. If high-side gauge reading rises, pinch-off must be corrected before proceeding.
12. Remove high-side process tube adaptor and solder process tube closed.
13. Clamp low-side process tube with pinchoff tool while unit is running. Remove low-side process tube adaptor and solder process tube closed.
14. Check process tubes for refrigerant leaks.

FINAL LEAK TEST

1. With refrigerator turned OFF, leak test all low-side system components.
2. Turn unit ON and run until condenser is warm. Leak test high-side system components.

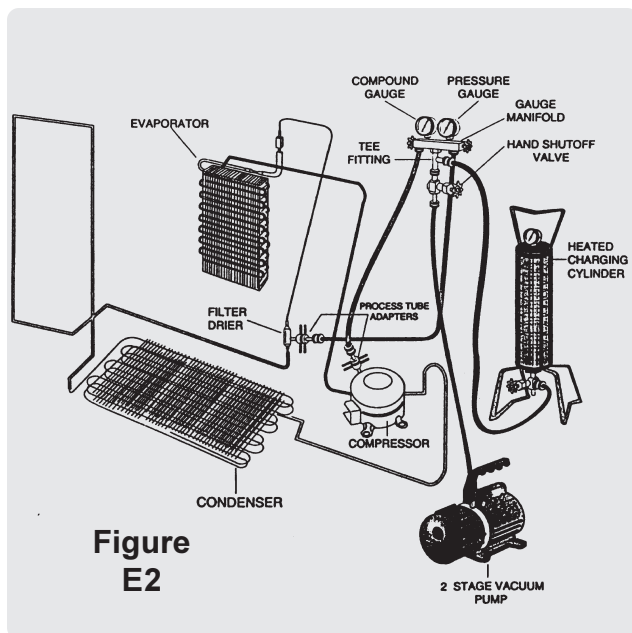

R-134a SERVICE INFORMATION

NOTICE: Instructions given here are furnished as a guide. Persons attempting to use these instructions to make repairs to the sealed refrigeration system should have a working knowledge of refrigeration and previous training on sealed system repair.

VERIFY REFRIGERANT TYPE IN THE SYSTEM

CAUTION: R-134a and R-12 are completely incompatible. Before starting any sealed system repair, it is extremely important to check serial plate of product to verify the type of refrigerant in the system.

Dedicated Equipment

R-134a must not be mixed with other types of refrigerants. R-134a must be recovered in dedicated and properly identified recovery bags and tanks.

Check with the manufacturer of your recovery equipment to determine R-134a compatibility. Some recovery equipment manufacturers have changeover instructions for switching between refrigerant types. Protect yourself and your equipment by following all manufacturer guidelines.

Also, ensure that your refrigeration hoses are specifically for use with R-134a refrigerant. Research has shown that compounds in standard refrigeration hoses may enter sealed systems and ultimately restrict the cap tube in an R-134a system.

R-134a REFRIGERATION SYSTEMS

R-134 sealed refrigeration systems consist of the same basic components utilized in the R-12 systems.

There is a 10% to 15% discharge pressure increase using R-134a, with a 5% to 10% decrease in suction pressure when compared to the same product with an R-12 system operating at 90°F (32°C) ambient temperature. Lower suction pressures result from the lower density of R-134a refrigerant which effects refrigerant flow rate. R-134a systems commonly operate in a 1"-2" vacuum on the suction side.

Products using R-134a refrigerant will generally have a longer capillary tube to maintain a similar flow rate. Some models have a larger condenser to reduce the discharge pressures and lower start-up sound transmission.

MISCIBILITY OF R-134a AND ESTER OIL

A special synthetic oil known as Ester oil is used as a lubricant in refrigeration systems operating on R-134a. Ester oils are produced from alcohols and fatty acids

and are available in several different variants. Ester oils have a pleasant aroma reminiscent of fruit.

Ester oils generally include various types of additives for improving certain properties such as viscosity, temperature sensitivity, etc. These additives are often aggressive, so skin contact with Ester oils should be avoided.

One of the most important demands made on a refrigerant system is that the oil mix with the refrigerant. Since mineral oil and ordinary synthetic oil DO NOT mix with R-134a, Ester oil is used for lubrication. Ester oil dissolves in R-134a.

Ester oil is broken down by chlorine and cannot be used with R-12 (R-12 contains chlorine) or any other compound containing chlorine. Therefore, R-134a refrigeration systems have virtually no tolerance for chlorine molecules from CFC refrigerants (R-134a is an HFC refrigerant and contains no chlorine).

CAUTION: During R-134a service, it is extremely important to avoid using equipment that may contain residual amounts of mineral oil, CFC's or HCFC's which could enter and contaminate the sealed system.

For example, hoses that were used in a refrigeration system operating on R-12 may contain small quantities of mineral oil which can block the capillary tube in a system operating on R-134a. As little as one milligram may be sufficient to cause a blockage. In addition, sealed system components that have been used with CFC systems must not be used with R-134a systems. These components may contain residual amounts of refrigerant and oil which could damage an R-134a system.

At the earliest stage of developing R-134a, tests were carried out on a different type of synthetic oil known as Poly-Alkaline Glycol (PAG). This oil is also used in certain air conditioning systems for cars. PAG and Ester oil DO NOT mix with one another. Service equipment used for R-134a / Ester oil must not come into contact with PAG.

WATER IN THE REFRIGERATION SYSTEM

Even in very small quantities, water in any refrigeration system can cause the following problems:

- Ice plugs in capillary tubes.
- Copper plating in compressor.
- Reactions with organic materials in systems.
- Corrosion of metals.

R-134a and Ester oil will aggravate the problem of water in the refrigeration system. Ester oil may react with water vapor and is hydroscopic (it will absorb water if it comes in contact with humid air). Water is also more soluble in R-134a than R-12.

To minimize the water content whenever service work is performed, the refrigeration system should always be thoroughly evacuated through process tube adaptors on both the high and low sides of the system. Evacuation must be for a minimum of 30 minutes to at least a 29.9 inch (500 micron) vacuum.

VACUUM CHART		
Vacuum Inches Hg.	Microns	Boiling Point of Water °F
28.940	25000	77.9
29.530	10000	52.0
29.832	4600	32.0
29.882	1000	1.0
29.901	500	-11.2
29.915	150	-32.8
29.917	100	-38.2
29.919	50	-49.0

To achieve the required 29.9 inch (500 micron) vacuum, a properly maintained two-stage vacuum pump in good condition is required. A two-stage pump can reach a deeper vacuum than a single-stage because the exhaust from the first pumping stage is discharged into the second pumping stage. This means the second stage begins pumping at a lower pressure so a lower ultimate vacuum can be achieved (See 2-Stage Vacuum Pump, Figure E3).

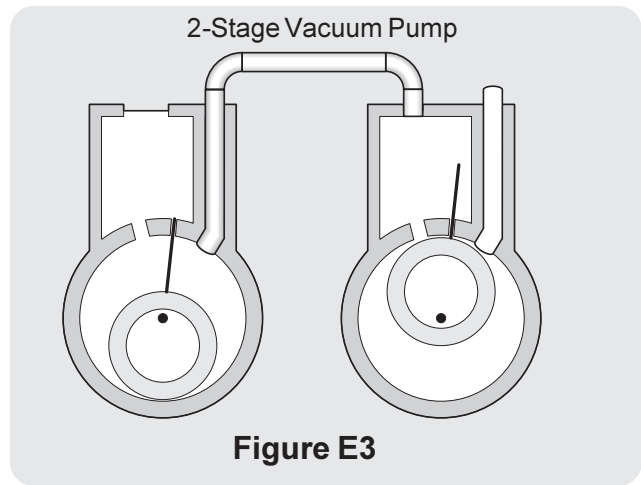

VACUUM PUMP MAINTENANCE

It is absolutely essential to maintain your vacuum pump according to the manufacturer's instructions including required oil changes at the recommended intervals. Vacuum pump oil should always be changed after evacuating a contaminated system. Vacuum pump performance should be checked periodically with a micron gauge.

Vacuum pump suppliers may or may not recommend changing the vacuum pump oil to the same type that's in the system being evacuated. Some manufacturers may recommend a vacuum pump that's dedicated to R-134a systems.

Robinair has stated that their current and discontinued vacuum pump models, using mineral oil currently specified for use in their vacuum pumps, can be used to evacuate R-134a/Ester oil systems. Robinair also states that it is acceptable to alternate between evacuating R-12/mineral oil and R-134a/Ester oil systems without adversely affecting the vacuum pump's performance.

For other brands of vacuum pumps, check with the manufacturer for restrictions and guidelines when using with R-134a.

CAUTION: If you use a vacuum pump with mineral oil to evacuate an R-134a system, it is ABSOLUTELY ESSENTIAL to have a shut-off valve between pump and your manifold gauge set as shown in Figure E4. The hand valve must be closed during all times when vacuum pump is not operating. This will prevent migration of mineral oil vapor into R134a/Ester oil system. If vacuum pump should stop during evacuation for any reason, the hand pump shut-off valve must be closed immediately.

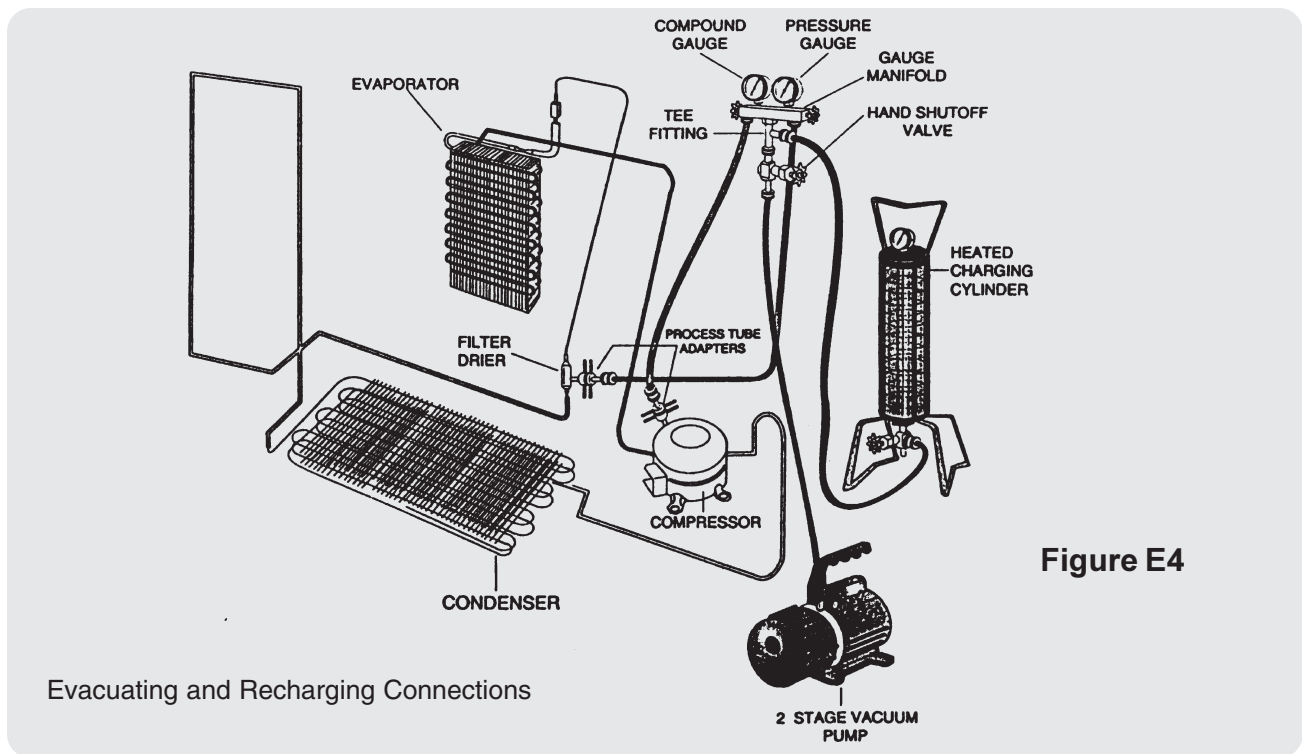

Figure E4

Evacuating and Recharging Connections

REFRIGERANT LEAKS

A system with R-134a and Ester oil will become saturated with moisture much faster than a system with R-12 and mineral oil. The compressor in an R-134a system will have to be replaced if the product has had a low side leak.

R-134a refrigerant molecules are smaller than R-12 molecules. This means that R-134a will pass more minor leaks and the rate of flow will be greater than for R-12. Therefore, it is now more important than ever to follow good brazing practices. Use a good grade of silver solder. 45% silver solder is recommended.

LEAK DETECTION

R-134a system leaks can be pinpointed by means of an electronic leak detector or by bubble solution.

Electronic leak detectors for R-134a service are currently available from several manufacturers. The least expensive models are non-selective detectors that will detect any type of emission or vapor present, regardless of its chemical composition. Some non-selective detectors designed for use with R-12 may have a much lower sensitivity when used with R-134a. However, newly designed detectors with good R-134a sensitivity are now available. Be sure to consult with the manufacturer before selecting or using a non-selective detector with R-134a.

Halogen-specific detectors use a specialized sensor that allows detection of compounds containing chlorine, fluorine, bromine, and iodine without being activated by other species. The major advantage of this type of

detector is a reduction in the number of “nuisance alarms”. Halogen-specific detectors are generally more expensive than non-selective detectors but feature higher sensitivity.

R-134a PROPERTIES

The properties of R-134a are very similar to those of R12. The principal data for the two refrigerants are shown in the chart below.

	REFRIGERANTS	
	R-12	R-134a
NAME	Dichlorodifluoromethane	1,1,1,2-Tetrafluoromethane
Formula	CCl ₂ F ₂	CH ₂ F-CF ₃
Molecular Weight (g/mol)	120.93	102.3
Ozone Depletion Potential (ODP)	1	0
Global Warming Potential (GWP)	3.1	0.3
Boiling Point °F	-21.6	-15.7
Vapor Pressure (77°F)	80 psig	82 psig
Flammability	None	None
Solubility of Water in Refrigerant (wt% @ 77°F)	0.009	0.11

HFC-134a, CFC-12 PRESSURE TEMPERATURE CHART

°F	°C	HFC-134a	CFC-12		°F	°C	HFC-134a	CFC-12
-60	-51.1	21.8*	19.0*		55	12.8	51.1	52.0
-55	-48.3	20.4*	17.3*		60	15.6	57.3	57.7
-50	-45.6	18.7*	15.4*		65	18.3	63.9	63.8
-45	-42.8	16.9*	13.3*		70	21.1	70.9	70.2
-40	-40.0	14.8*	11.0*		75	23.9	78.4	77.0
-35	-37.2	12.5*	8.4*		80	26.7	86.4	84.2
-30	-34.4	9.8*	5.5*		85	29.4	94.9	91.8
-25	-31.7	6.9*	2.3*		90	32.2	103.9	99.8
-20	-28.9	3.7*	0.6		95	35.0	113.5	108.3
-15	-26.1	0.0	2.4		100	37.8	123.6	117.2
-10	-23.3	1.9	4.5		105	40.6	134.3	126.6
-5	-20.6	4.1	6.7		110	43.3	145.6	136.4
0	-17.8	6.5	9.2		115	46.1	157.6	146.8
5	-15.0	9.1	11.8		120	48.9	170.3	157.7
10	-12.2	12.0	14.6		125	51.7	183.6	169.1
15	-9.4	15.0	17.7		130	54.4	197.6	181.0
20	-6.7	18.4	21.0		135	57.2	212.4	193.5
25	-3.9	22.1	24.6		140	60.0	227.9	206.6
30	-1.1	26.1	28.5		145	62.8	244.3	220.3
35	1.7	30.4	32.6		150	65.6	261.4	234.6
40	4.4	35.0	37.0		155	68.3	279.5	249.5
45	7.2	40.0	41.7		160	71.1	298.4	265.1
50	10.0	45.3	46.7		165	73.9	318.3	281.4

FIGURES WITH ASTERISKS (*) = IN. HG. VACUUM

FIGURES WITHOUT ASTERISKS = PSIG

R-134A HEALTH AND SAFETY INFORMATION

INHALATION TOXICITY

HFC-134a poses no acute or chronic hazard when it is handled in accordance with DuPont recommendations and when exposures are maintained at or below the DuPont Acceptable Exposure Limit (AEL) of 1,000 ppm (8 and 12 hour Time-Weighted Average or TWA).

An AEL is an airborne exposure limit established by DuPont scientists that specifies time-weighted average (TWA) airborne concentrations to which nearly all workers may be repeatedly exposed without adverse effects. The AEL for HFC-134a has the same value as the Threshold Limit Values (TLVs) established for CFC-12 and HCFC-22. TLVs are established by the American Conference of Governmental and Industrial Hygienists (ACGIH).

However, inhaling high concentrations of HFC-134a vapor may cause temporary central nervous system depression with narcosis, lethargy and anesthetic effects. Other effects that may occur include dizziness, a feeling of intoxication and a loss of coordination. Continued breathing of high concentrations of HFC-134a vapors may produce cardiac irregularities (cardiac sensitization), unconsciousness, and with gross overexposure, death. Intentional misuse or deliberate inhalation of HFC-134a may cause death without warning. This practice is **extremely dangerous**.

If you experience any of the initial symptoms, move to fresh air and seek medical attention.

CARDIAC SENSITIZATION

If vapors are inhaled at a concentration of 75,000 ppm, which is well above the AEL, the heart may become sensitized to adrenaline, leading to cardiac irregularities and, possibly, to cardiac arrest. The likelihood of these cardiac problems increases if you are under physical or emotional stress.

Medical attention must be given immediately if exposed to high concentrations of HFC-134a. **DO NOT** treat with adrenaline (epinephrine) or similar drugs. These drugs may increase the risk of cardiac arrhythmias and cardiac arrest. If the person is having difficulty breathing, administer oxygen. If breathing has stopped, give artificial respiration.

SPILLS OR LEAKS

If a large release of vapor occurs, such as from a large spill or leak, the vapors may concentrate near the floor or low spots and displace the oxygen available for breathing, causing suffocation.

Evacuate everyone until the area has been ventilated. Use blowers or fans to circulate the air at floor level. **DO NOT** reenter the affected area unless you are equipped with a self-contained breathing apparatus or unless an area monitor indicates that the concentration of HFC-134a vapors in the area is below the AEL.

Always use self-contained breathing apparatus or an air-line mask when entering tanks or other areas where vapors might exist. Use the buddy system and a lifeline. Refer to the Material Safety Data Sheet (MSDS) for HFC-134a for more information.

HFC-134a vapors have a slightly sweet odor that can be difficult to detect. Therefore, frequent leak checks and the installation of permanent area monitors may be necessary in enclosed spaces. Refer to ASHRAE Standards 15 and 34 for refrigeration machinery rooms.

To ensure safety when working with HFC-134a in enclosed areas:

1. Route relief and purge vent piping (if present) outdoors, away from air intakes.
2. Make certain area is well ventilated, using auxiliary ventilation, if necessary, to move vapors.
3. Ensure that area is clear of vapors prior to beginning work.
4. Install air monitoring equipment to detect leaks.

SKIN AND EYE CONTACT

At room temperature, HFC-134a vapors have little or no effect on the skin or eyes. However, in liquid form, HFC-134a can freeze skin or eyes on contact, causing frostbite. Following contact, soak the exposed area in lukewarm water, not cold or hot. If medical treatment cannot begin immediately, apply a light coat of a nonmedicated ointment, such as petroleum jelly. If the exposed area is in a location where the presence of the ointment would be awkward, such as on the eye, apply a light bandage. In all cases of frostbite, seek medical attention as soon as possible.

Always wear protective clothing when there is a risk of exposure to liquid HFC-134a. Where splashing is possible, **always** wear eye protection and a face shield.

COMBUSTIBILITY OF HFC-134a

HFC-134a is nonflammable at ambient temperatures and atmospheric pressure. However, tests have shown HFC-134a to be combustible at pressures as low as 5.5 psig (139.3 kPa absolute) at 177°C (350°F) when mixed with air at concentrations generally greater than 60% volume air. At lower temperatures, higher pressures are required for combustibility. (HCFC-22 is also combustible at pressures above atmospheric in the presence of high air concentrations). Test results and calculations have shown:

- At ambient temperature, all concentrations of HFC-134a in air are nonflammable at pressures below 15 psig (205 kPa absolute).
- Combustible mixtures of air and HFC-134a will not form when liquid HFC-134a is pumped into closed vessel if initial air pressure in vessel is limited to one atmosphere absolute and final pressure is limited to 300 psig (2,170 kPa absolute). If initial air pressure is greater than one atmosphere, combustible mixtures may form as tank is filled.

Based on above information, the following operating practices are recommended:

Leak Testing

- Equipment should **NEVER** be leak tested with a pressurized mixture of HFC-134a and air. HFC-134a may be safely pressured with dry nitrogen.

Bulk Delivery and Storage

- Tanks should normally be evacuated at start of filling, and should never be filled while under positive air pressure.
- Tank pressure should never be allowed to exceed 300 psig (2,170 kPa) when filling with HFC-134a. Relief devices on either tanks or HFC-134a supply system usually prevent this.
- Tank pressures should be monitored routinely.
- Air lines should never be connected to storage tanks.

Filling and Charging Operations

- Before evacuating cylinders or refrigeration equipment, any remaining refrigerant should be removed by recovery system.
- Vacuum pump discharge lines should be free of restrictions that could increase discharge pressures above 15 psig (205 kPa) and result in formation of combustible mixtures.
- Cylinders or refrigeration equipment should normally be evacuated at start of filling, and should never be filled while under positive air pressure.
- Final pressures should not exceed 300 psig (2,170 kPa).
- Filled cylinders should periodically be analyzed for air (nonabsorbable gas or NAG).

Refrigerant Recovery Systems

Efficient recovery of refrigerant from equipment or containers requires evacuation at the end of the recovery cycle. Suction lines to a recovery compressor should be periodically checked for leaks to prevent compressing air into the recovery cylinder during evacuation. In addition, the recovery cylinder pressure should be monitored, and evacuation stopped in the event of a rapid pressure rise indicating the presence of noncondensable air. The recovery cylinder contents should then be analyzed for NAG, and the recovery system leak checked if air is present. **DO NOT** continue to evacuate a refrigeration system that has a major leak.

THERMAL DECOMPOSITION

HFC-134a vapors will decompose when exposed to high temperatures from flames or electric resistance heaters. Decomposition may produce toxic and irritating compounds, such as hydrogen fluoride. The pungent odors released will irritate the nose and throat and generally force people to evacuate the area. Therefore, it is important to prevent decomposition by avoiding exposure to high temperatures.

SECTION F - ICE MAKER

ICE MAKER FOR TOP MOUNT MODELS

The automatic Ice Maker is mounted in the freezer compartment. It is attached to the freezer compartment's left wall with two screws and can be removed for servicing.

The Ice Maker is designed to produce ice automatically. The length of time between Harvest Cycles will vary, depending on load conditions, door openings, ambient temperature and freezer temperature. These factors must be taken into consideration when checking the ice production rate.

With a temperature of -2°F to $+5^{\circ}\text{F}$ in the freezer, the rate of harvest will be 8 - 12 cycles per 24 hour period.

The Ice Maker is wired across the line and will harvest ice in the refrigeration or defrost cycles.

The Water Valve and Solenoid Assembly are both mounted in the compressor compartment.

A $3/16$ " polyethylene tube extends from the water valve up the rear wall of the refrigerator to a water inlet spout that directs the water into the fill trough. A bead of sealer around the inlet water tube prevents the migration of air and moisture into the freezer compartment.

Front Cover

A decorative front cover, made of molded plastic, encloses the operating mechanism of the Ice Maker, protecting it from moisture. It is essential that the cover be in place on an operating Ice Maker to protect against possible contact with the mechanism by the user. (See Figure F1)

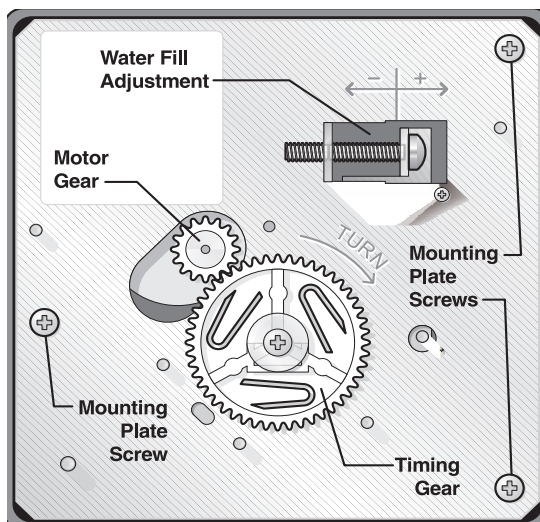

Figure F1

ICE MAKER COMPONENTS

Ice Mold

The Ice Mold is die-cast aluminum with the Ice Maker Thermostat bonded to its front surface. The Mold has a semi-circular interior partitioned into equal size compartments. Water enters at the rear of the Mold, through a fill trough. A film of silicon grease on the top edge of the Mold prevents siphoning of water by capillary action.

Mold Heater

A Mold Heater, rated at 115volts, 81 ohms $\pm 10\%$ or 230 volts, 340 ohms $\pm 10\%$, and covered with an aluminum sheath, is embedded in the grooved section on the underside of the Mold. When the Mold Heater is energized, the ice contact surface within the Mold is heated enough to allow harvest of the ice pieces.

The Mold Heater is wired in series with the Ice Maker Thermostat, which acts as a safety device.

The original heater is staked in place, but can be removed for replacement. The replacement heater is secured to the Mold by four flat head retaining screws that thread into holes in the Mold, adjacent to the heater.

A thermal mastic sealer is placed between the heater and the Mold to ensure good thermal contact.

Ice Stripper

An Ice Stripper is attached to the Mold to prevent ice pieces from falling back into the Mold. It also serves as a decorative side cover.

Ice Ejector

The Ejector blades are molded from Delrin, and extend from a central shaft, which turns in nylon bearings at the front and rear. Each blade sweeps an ice section out of the Mold. The drive end of the Ice Ejector is "D" shaped. Silicone grease is used to lubricate the bearing surfaces.

Water Valve Assembly

The Water Valve is solenoid operated and when energized, releases water from the supply line into the Ice Mold. The amount of water released is directly proportional to the length of time the Water Valve Switch is energized. A flow washer, inside the Water Valve, maintains a constant rate of water flow over a supply line pressing ranging from 15 to 100 psig. It will not compensate for pressures below 15 psig, or greater than 100 psig. A No. 80-mesh screen, placed ahead of the flow washer, filters out foreign materials.

The solenoid coil draws 10 to 115 watts of power. The coil is wired in series with the Mold Heater, across the supply voltage.

Thermostat

The Thermostat is a single-pole, single throw (SPST), bimetallic, disk-type, thermal switch. It automatically starts the Harvest Cycle when the ice is frozen. The Thermostat closes at a temperature of $18^{\circ}\text{F} \pm 6^{\circ}$. Wired in series with the Mold Heater, the Thermostat acts as a safety device against overheating in the event of mechanical failure. A thermal mastic bond is provided where the Thermostat is mounted against the Mold. A gasket prevents water from leaking into the support housing.

Sensing Arm & Linkage

The Sensing Arm is cam-driven and operates a switch that controls the quantity of ice produced. In the Harvest Cycle, the arm is raised and lowered during each of the two revolutions of the timing cam. If the Sensing Arm comes to rest on top of ice in the storage compartment during either revolution, the switch will remain open and stop the Ice Maker at the end of that revolution. When sufficient ice is removed from the Storage Container, the Sensing Arm lowers and ice production resumes. To manually stop the Ice Maker, raise the Sensing Arm until it locks in the upper position. Operation is resumed when the Sensing Arm is manually lowered.

Timing Switches (See Figure F2)

The three Timing Switches used are single-pole, double throw (SPDT). They are identical except for function, and can be used interchangeably.

1. **Hold Switch** - Assures completion of a revolution once the Ice Maker operation has started.
2. **Water Fill Switch** - Opens the Water Valve during the Fill Cycle. It is the only adjustable component in the Ice Maker.
3. **Shut-Off Switch** - Stops Ice Maker operation when the Storage Container is full of Ice. The switch is opened after the Sensing Arm is raised to its most upright position. The switch is mounted to the top right wall of the Ice Maker Support. (Not shown in Figure F2)

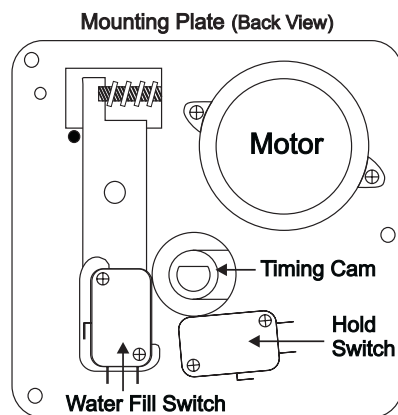

Figure F2

Thermal Cut-Out (TCO)

The Thermal Cut-Out is a one-time limit fuse used as a safety device. It is located under the mounting plate, in the head of the Ice Maker, between the Thermostat and wire connector.

If the Thermal Cut-Out opens, the cause of failure must be determined and corrected prior to replacing the TCO. Normal causes of the TCO failing are a bad Thermostat or a shorted coil on the water valve.

Timing Cam & Coupler

Three separate cams are combined in one molded Delrin part:

1. Inner Cam operates Shut-Off Switch lever arm.
2. Center Cam operates Hold Switch.
3. Outer Cam operates Water Fill Switch.

One Cam end is attached to a large Timing Gear. The other Cam end is coupled to the Ejector.

Timing Gear

This large molded plastic gear is driven by the Motor and, in turn, rotates the Cam and Ejector. A "D" shaped hole in the gear fits over the Timing Cam Hub. Spacer tabs on the backside of the gear prevent the gear from binding on the mounting plate.

Motor

A low wattage, stall-type Motor drives the Timing Gear. This gear turns the Timing Cam and Ejector Blades approximately one revolution every three minutes (1/3 RPM).

Fill Trough

The Fill Trough is molded nylon. It supports the Inlet Tube and directs the water into the Mold. It also forms a bearing for one end of the Ejector Blades.

Wiring

A four-prong plug connects the Ice Maker wiring to the cabinet wiring harness. (See Figure F3.) The Ice Maker Assembly is wired across the line and will harvest in either the Refrigeration or Defrost Cycles. A wiring diagram is located inside the front cover of the Ice Maker.

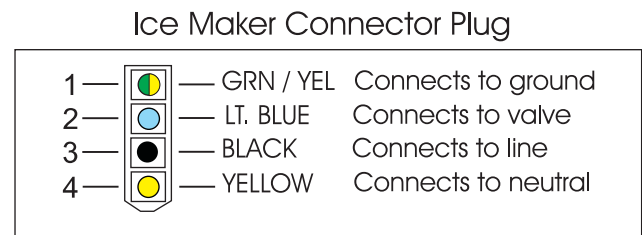

Figure F3

INSTALLING WATER SUPPLY LINE TO ICE MAKER

Supply line installation must comply with all applicable plumbing codes. Refer to the **Ice Maker Installation Instructions** in appendix A.

The ¼" tubing, and any other plumbing materials required, should be obtained locally.

The Ice Maker should be connected to a frequently used cold water line to ensure a fresh water supply.

NOTE: A vertical cold water line should be selected for the water supply. If a vertical line is not available, a horizontal line may be used, providing the connection is on the side or top of the pipe, but **not on the bottom**. Scale and foreign material in the pipe could cause stoppage of water flow if the connection is on the bottom.

Be sure to leak test all connections after the water supply has been turned on.

TEST CYCLING ICE MAKER (See *Ice Maker Testing Procedures* on pages 51-60).

It may be necessary, on occasion, to test-cycle an Ice Maker to check its operation. This can be done on the repair bench or while mounted in the Refrigerator.

If the Ice Maker is in an operating refrigerator, take precautions against the formation of condensate by allowing the cold, metal components to warm up before removing the front cover. This can be expedited by cycling the assembly with the cover in place and the water supply valve closed.

To manually cycle the Ice Maker, slowly turn the Ejector blades clockwise until the Hold Switch circuit to the Motor is completed. When the Motor starts, all components except the Ice Maker Thermostat should perform normally. Once the Ice Maker completes its cycle, remove the front Cover; see instructions for replacing the front Cover in "**To Replace Front Cover**" on this page.

If further test cycling is necessary, place screwdriver blade in slot located in the Motor Drive Gear and turn counterclockwise until the Hold Switch circuit to the Motor is completed.

WATER VALVE SWITCH – WATER FILL VOLUME

The amount of water fill is directly proportional to the length of time terminals "C-NC" of the Water Fill Switch are closed. Closing occurs when the switch plunger drops into a cavity formed in the Cam.

Different water valves have different flow rates. For this reason, anytime a Water Valve is replaced, the Water Fill Switch must be adjusted.

The correct water fill volume is 95-105 cc. To measure the fill volume, test-cycle the Ice Maker and collect the water. Measure in a container calibrated in cubic centimeters (cc) or ounces.

The fill volume is adjusted by increasing or decreasing the length of time the Water Fill Switch remains closed.

To adjust the Water Fill Switch, first determine how much water is needed. The adjusting screw is calibrated so that one complete revolution changes the water fill about 18 cubic centimeters. Turning the screw clockwise decreases the fill, while turning counterclockwise increases the fill.

EXAMPLE: An Ice Maker is test-cycled and the water fill sample is 158 cubic centimeters. Subtracting 145 cc from 158, the adjustment needed is 13 cc. Since one turn of the adjusting screw changes the fill 18 cc, ¾ of a turn clockwise would reduce the fill about 13 cc, the desired amount. (This example is for manual models only.)

PARTS REPLACEMENT

Disconnect electrical supply to refrigerator. If the Refrigerator is operating and cold, allow the Ice Maker to warm up to room temperature before removing the front cover. This prevents moisture from condensing on the metal components.

To Replace Front Cover (See Figure F4)

1. Ensure that Ice Maker is at room temperature before removing Cover.
2. Place straight blade of screwdriver in slot at bottom of Mold Support and pry Cover loose.

NOTE: Ensure that the retaining tabs inside the Cover are located on the top and bottom when installing the Cover.

3. Snap Cover in place.

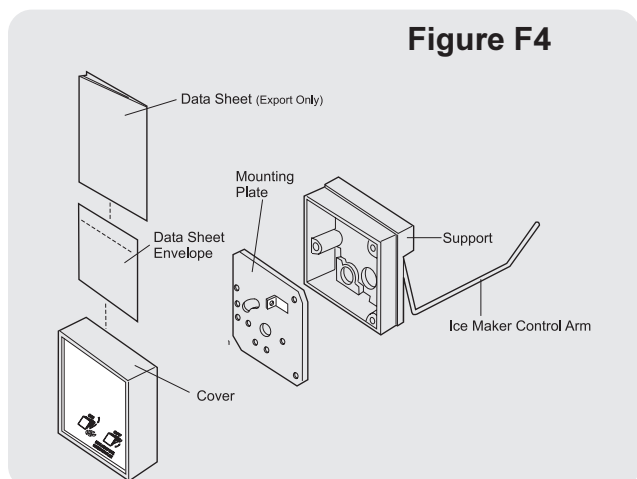

To Replace Fill Trough and Bearings

1. Push Trough retaining tab back away from Mold.
2. Rotate Trough counterclockwise until it is clear.
3. Pull from back to detach from Mold and Ejector Blades.
4. Replace in reverse order.

To Replace Ice Stripper

1. Remove Ice Maker from refrigerator.
2. Remove retaining screw at back of mold.
3. Pull back on Ice Stripper to disengage it from front of Mold Support housing.
4. Replace in reverse order.

To Replace Ejector Blades

1. Remove front Cover.
2. Remove three screws holding Mounting Plate in place.
3. Carefully remove Mounting Plate, disengaging end of Ice Maker Control Arm and Ejector Blades from Motor coupling, noting relative position of Ice Maker Control Arm Spring.
4. Remove Fill Trough and bearing.
5. Turn blades to 12 O'clock position.
6. Slide Ejector Blades back and up to remove.
7. Replace in reverse order.
8. Lubricate bearing ends of Ejector with Silicone grease.

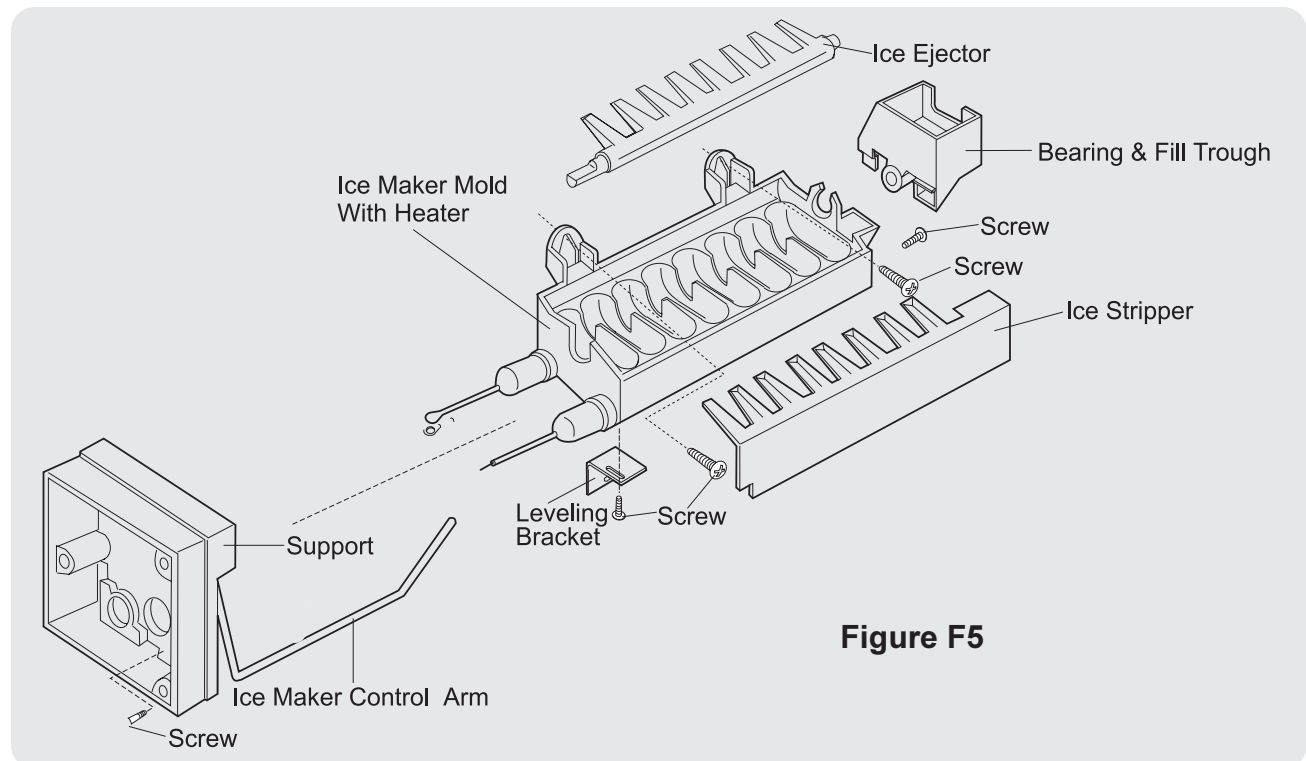

Figure F5

To Replace Motor and Switch Mounting Plate

1. Remove front Cover.
2. Remove three screws that attach Mounting Plate to Support Housing.
3. Carefully remove Mounting Plate, disengaging end of Sweep Arm and noting relative position of Sweep Arm Spring.
4. Transfer Motor, Switches, Cam, Gear, and Water Fill Adjusting Spring and Arm to replacement Mounting Plate.
5. Attach new Mounting Plate to Support Housing with three screws.

NOTE: Ensure that the wiring harness is properly positioned and the Sweep Arm is in place.

6. Check Water Fill Cycle and adjust as required.
7. Replace front Cover.

To Replace Motor

1. Remove front Cover.
2. Remove three screws that attach Mounting Plate to Support Housing.
3. Disconnect two Motor leads.
4. Remove two Motor mounting screws.
5. Replace Motor in reverse order.

To Replace Water Fill Switch

1. Remove front Cover.
2. Remove three screws that attach Mounting Plate to Support Housing.
3. Disconnect two Water Fill Switch wire leads.
4. Remove two switch mounting screws.
5. Remove switch.
6. Replace switch in reverse order, ensuring that switch insulator is in place.
7. Check Water Fill Cycle and adjust as required.

To Replace Hold Switch

1. Remove front Cover.
2. Remove three screws that attach Mounting Plate to Support Housing.
3. Disconnect six Hold Switch wire leads.
4. Remove two Hold Switch mounting screws.
5. Remove Hold Switch.
6. Replace in reverse order.

To Replace Ice Maker Control Arm Shut-Off Switch

1. Remove front Cover.
2. Remove three screws that attach Mounting Plate to Support Housing.
3. Disconnect three Ice Maker Control Arm Shut-Off Switch wire leads.
4. Raise Ice Maker Control Arm Lever.
5. Remove two Ice Maker Control Arm Shut-Off Switch mounting screws.
6. Remove switch.
7. Replace switch in reverse order.

To Replace Ice Maker Thermostat

1. Remove front Cover.
2. Remove three screws that attach Mounting Plate to Support Housing.
3. Loosen two Thermostat retaining clip mounting screws.
4. Disconnect two thermostat wire leads and remove thermostat.
5. Apply thermal mastic sealer to sensing surface of replacement thermostat to ensure a positive bond to mold.
6. Replace thermostat in reverse order.

To Replace Thermal Cut-Out (TCO)

1. Remove front Cover.
2. Remove three screws that attach Mounting Plate to Support Housing.
3. Pull cable assembly free from support housing. It will slide out easily.
4. Loosen screw securing clamp to TCO. TCO should come free after tension from clamp is released.
5. Disconnect TCO from two wire nuts. One end is connect to the cable assembly and the other end is connected to the motor and mold heater.
6. Replace with new TCO.
7. Reassemble in reverse order.

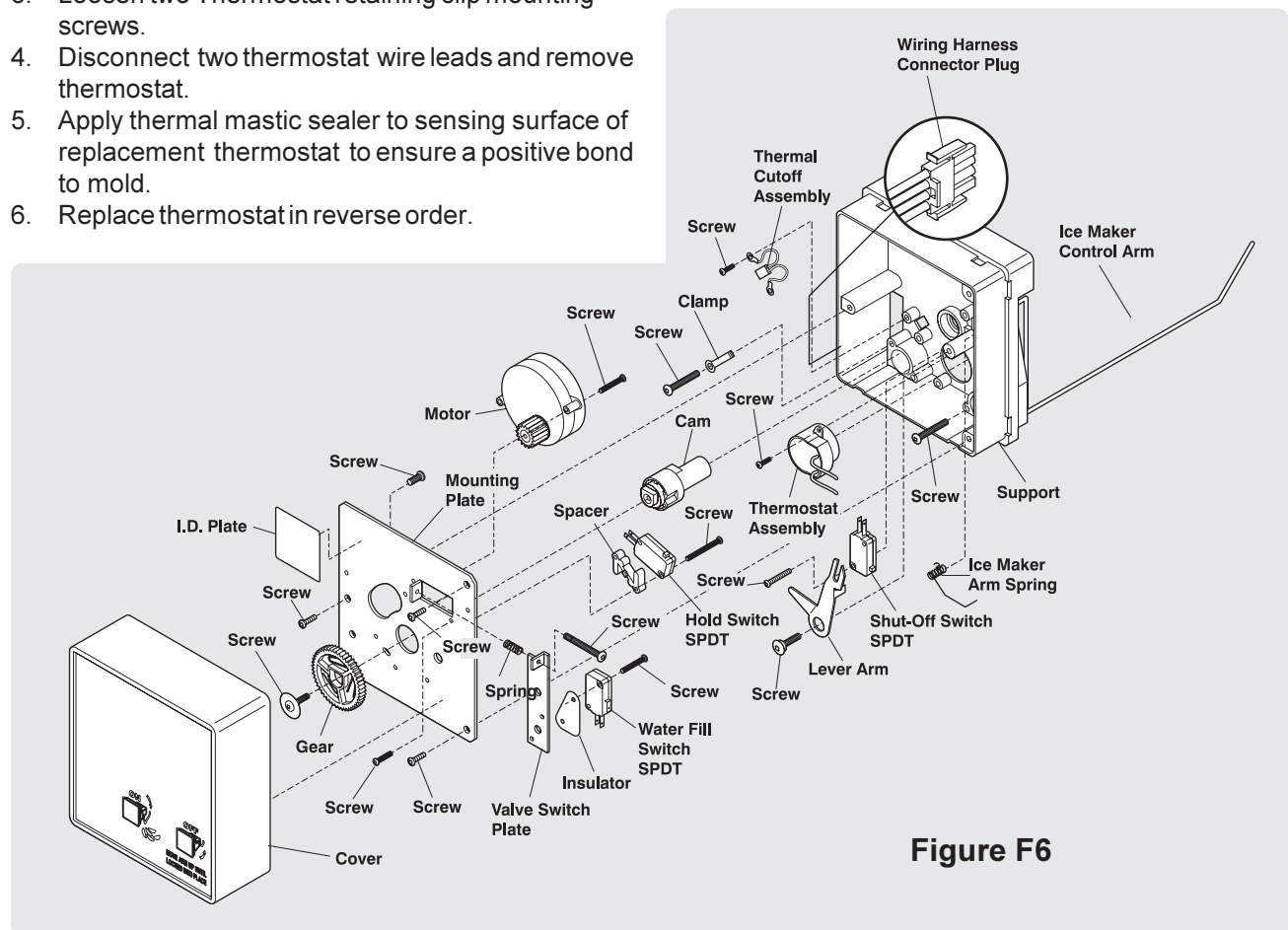

Figure F6

To Replace Mold Heater

1. Remove front Cover.
2. Remove Ice Stripper. (Refer to Section "To Replace Ice Stripper" on page 48)
3. Remove three screws that attach Mounting Plate to Support Housing.
4. Remove three screws that attach Mold to Support Housing.

NOTE: One of the three screws is attached to the two Green/Yellow ground wires and another one is holding the Clamp in place. The third screw is located in the lower right corner of the Support Housing.

5. Unscrew wire nut holding three black leads together and separate them.

NOTE: One black lead is connected to the Mold Heater. Another is connected to the Thermostat and the third lead goes to the Hold Switch.

6. Disconnect remaining Mold Heater lead connected to brown Motor lead and black Thermal Cut-Out lead.
7. Separate Mold from Support Housing.

NOTE: Be careful not to destroy the thermostat gasket located between the mold and support housing.

8. Remove hex head screw holding Ice Maker Leveling Bracket to Mold.

NOTE: The Mold is crimped in six places, holding the Mold Heater firmly in the Mold groove. It may be necessary to use a hammer and screwdriver to remove the heater from the Mold groove.

9. Use a flat-bladed screwdriver to pry inoperative heater from Mold groove.
10. Clean remaining thermal mastic sealer from Mold groove.
11. Apply layer of thermal mastic sealer to Mold groove.
12. Install replacement Mold Heater.
13. Replace parts in reverse order. Ensure that Thermostat gasket is in place. Bond the Thermostat to Mold with thermal mastic sealer.

NOTE: For best operation, the freezer temperature should be between -2°F to +4°F.

FAULT DIAGNOSIS

Complaint - Ice Maker Fails to Start

1. Check to see if Ice Maker Control Arm is locked in raised position.
2. Check terminals from Cabinet wiring to Ice Maker for open circuit in wiring or components.
3. Check operation of the Maker with test service cord.

4. Check Mold temperature at a mounting screw. If temperature is above 15°F, freezer air temperature is not cold enough to switch Ice Maker Thermostat to closed position. If Mold is below 9°F, manually start Ice Maker by rotating Timer gear. If motor fails to start, check Motor for continuity. If Motor starts, Thermostat, Shut-Off Switch, or Hold Switch is inoperative.
5. Check Hold Switch first. With Ejector blades in the starting position, check terminals "C" and "NC" for continuity. Replace switch if continuity readings are open. Check Shut-Off Switch linkage. Then check terminals "NO" and "C" for continuity with Ice Maker Control Arm in lowest position. Replace switch if continuity readings are open. If Hold Switch and Shut-Off Switch are operative, then replace Thermostat.

Complaint-Ice Maker Fails to Complete Cycle.

1. With Ejector blades at 10 o'clock position, Hold Switch Plunger depressed, Check terminals "C" and "NO" for continuity. Replace switch if continuity readings are open.
2. With Ejector blades at 12 o'clock position, check Shut-Off Switch terminals "C" and "NC" for continuity. Replace Thermostat if continuity readings are open.
3. With Ejector blades at 4 o'clock position, check Mold Heater and Ice Maker Thermostat for continuity. Replace heater if continuity readings are open. If heater shows continuity, replace Thermostat.
4. Check Motor operation with a test cord. Replace Motor if it fails to start.

Complaint-Ice Maker Fail to Stop at End of Cycle

With the Ejector blades in the starting position, check the Hold Switch terminals "C" and "NO" for continuity. Replace the switch if the continuity readings are indicating a closed circuit.

Complaint-Ice Maker Continues to Eject When Container is Full.

1. Check for loose linkage to the Ice Maker Control arm Shut-Off Switch. Switch should open when arm is in raised position. Adjust, if required.
2. Check Shut-Off Switch terminals "C" and "NO" for continuity with Ice Maker Control Arm raised. Replace switch if continuity readings are indicating a closed circuit.

Complaint-Ice Maker Produces Undersized Ice Pieces

1. Ensure that Ice Maker mold is level.
2. Check for partial restriction in supply line or Water Valve Strainer.
3. Ensure that the water pressure to Water Valve is sufficient. (20 psi min., 120 psi max.)
4. Ensure that the Water Valve Switch is adjusted for proper water fill, 90-105 cc's.
5. Check thermal bond between Thermostat and Mold. If necessary, rebond with thermal mastic sealer.

ICE MAKER TESTING PROCEDURES

Operating Cycle

The operation of the Ice Maker, water refilling, and controlled ice storage, require proper functioning and timing of all components.

Consider the following:

- Has refrigerator been properly installed and connected to sources of electrical power and water?
- Has Freezer compartment Evaporator pulled down to temperature?
- Have several ice making cycles been completed and is the Ice Maker in the Freeze Cycle?
- Is the Ice Maker Thermostat single-throw switch in series with the Mold Heater?
- Do the Ejector Blades make two revolutions per cycle? Is ice stored on blades after harvest?
- Is the Water Solenoid wired in series with the Mold Heater?

Operating Cycle Illustrations - Manual Cycle

To manually cycle Ice Maker:

1. Remove Cover from Ice Maker head.
2. Insert a Phillips® into screw on timing gear.
3. Turn gear clockwise until Motor starts to run.

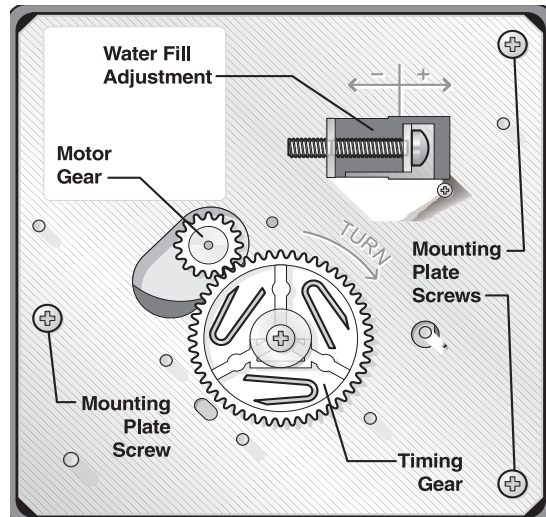

Operating Cycle Illustrations - Electrical

The following wiring diagrams illustrate the electrical operation of an Ice Maker. This procedure is on the Internet at <http://www.frigidaire.com/tip/>

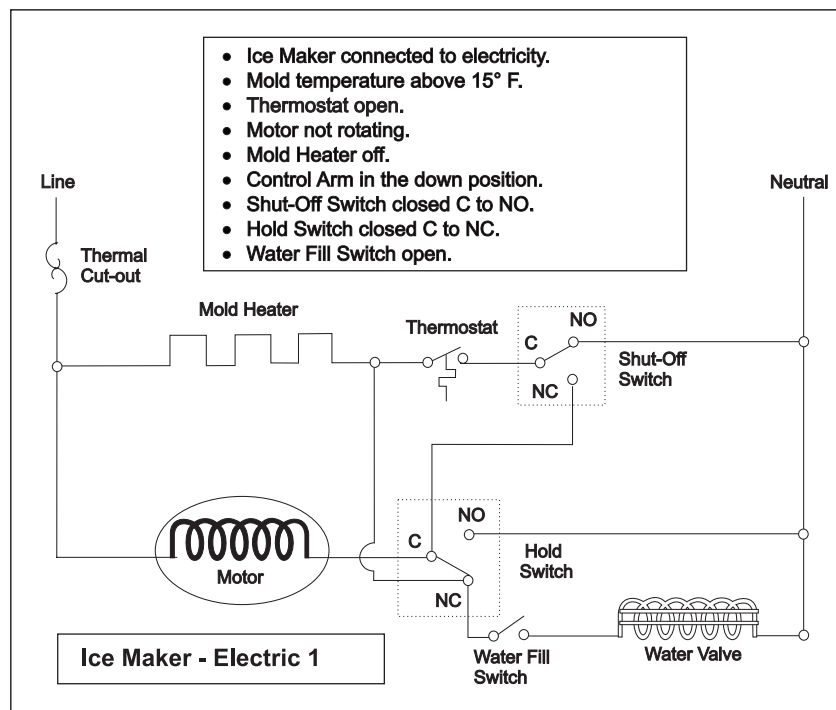

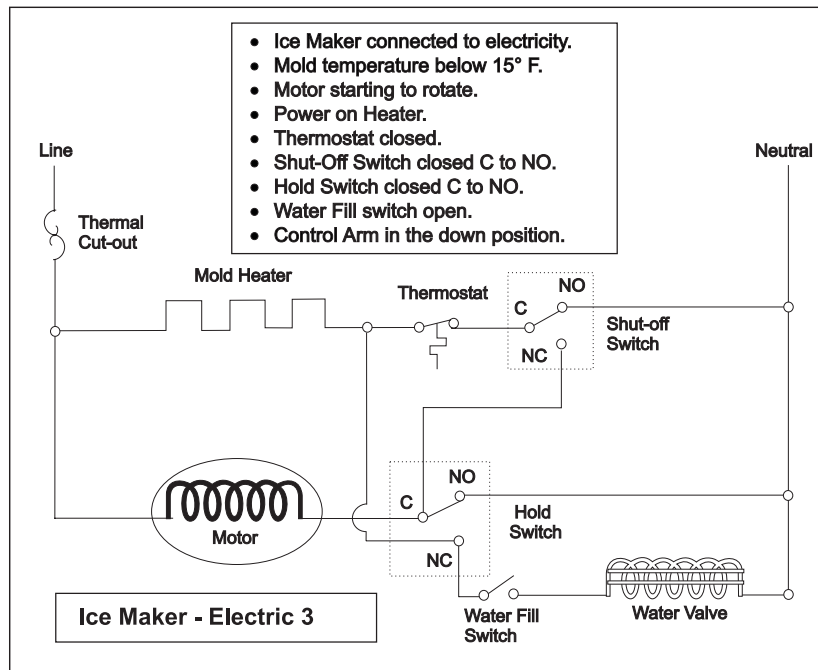
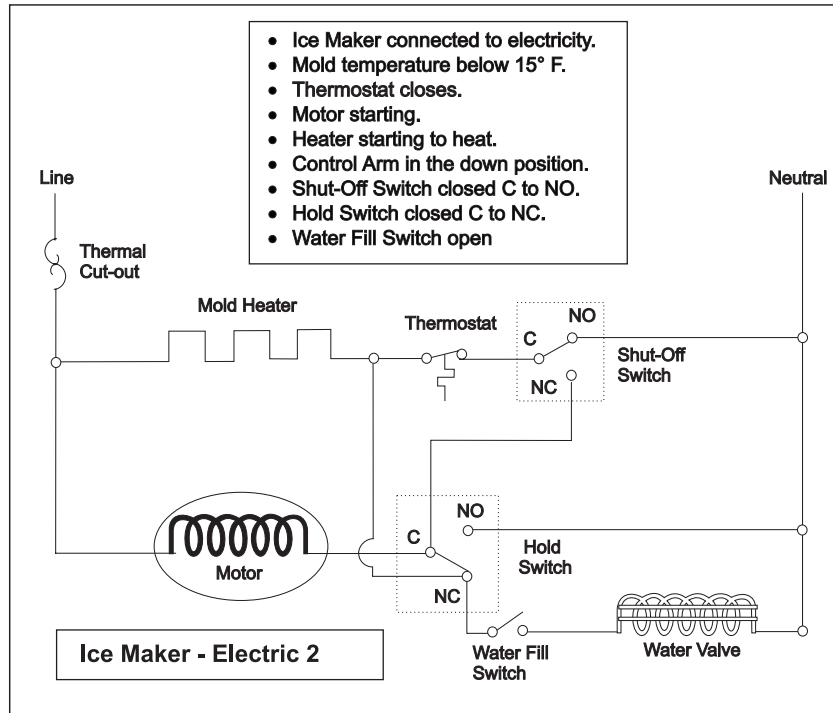

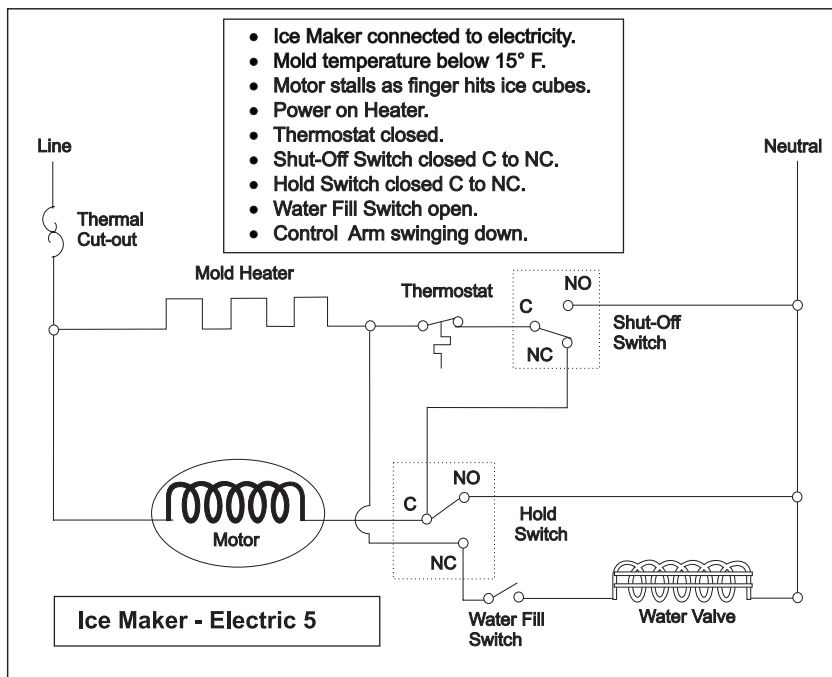
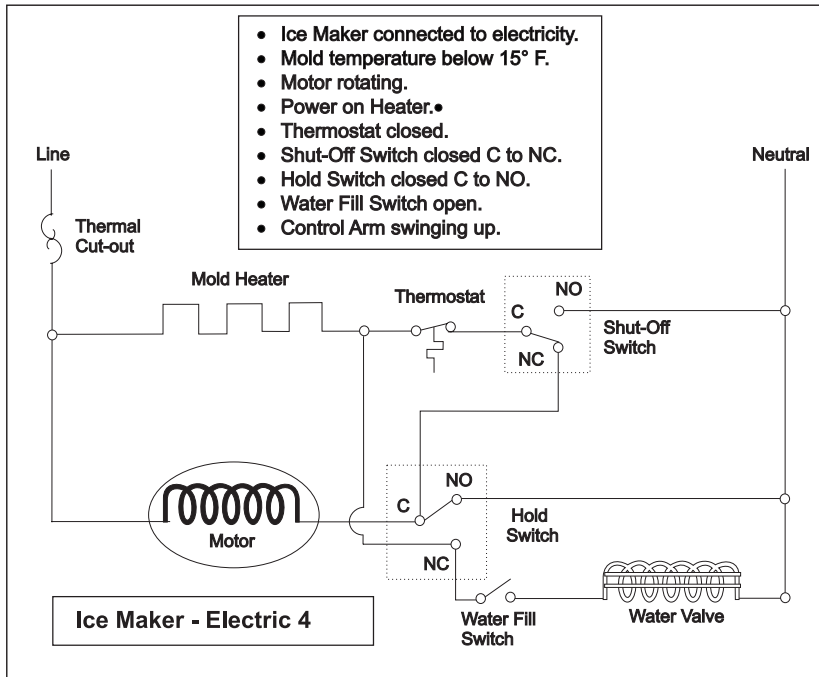

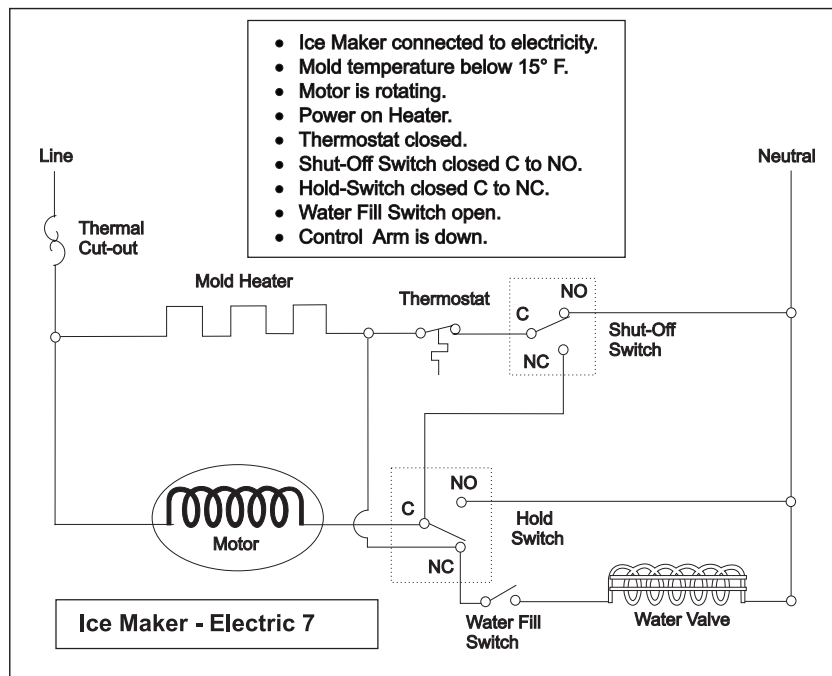
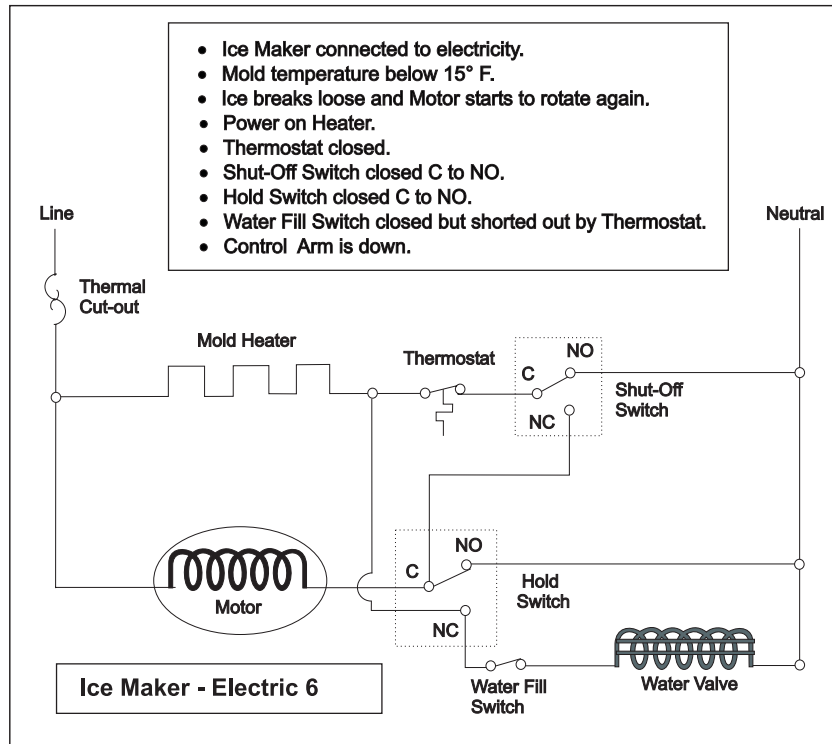

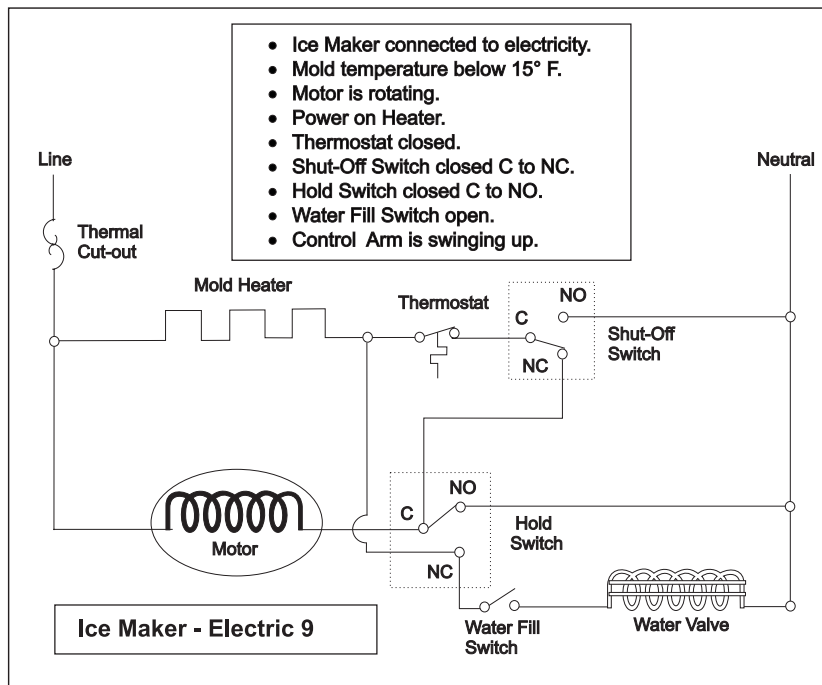
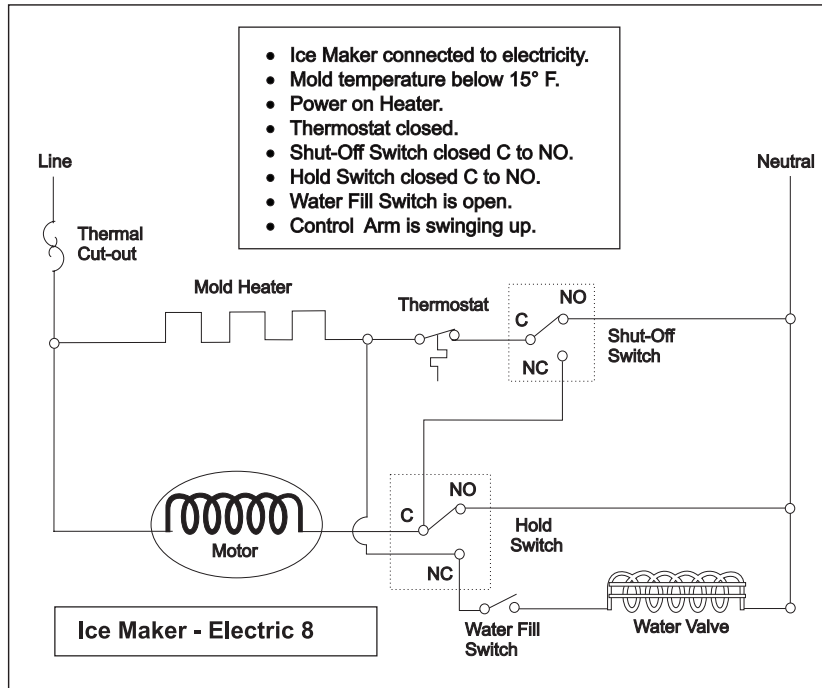

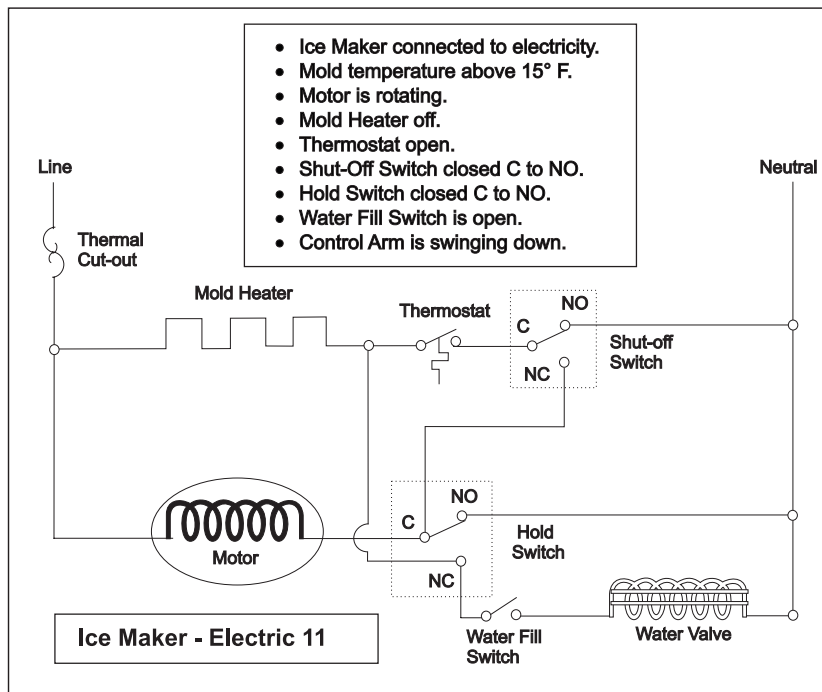
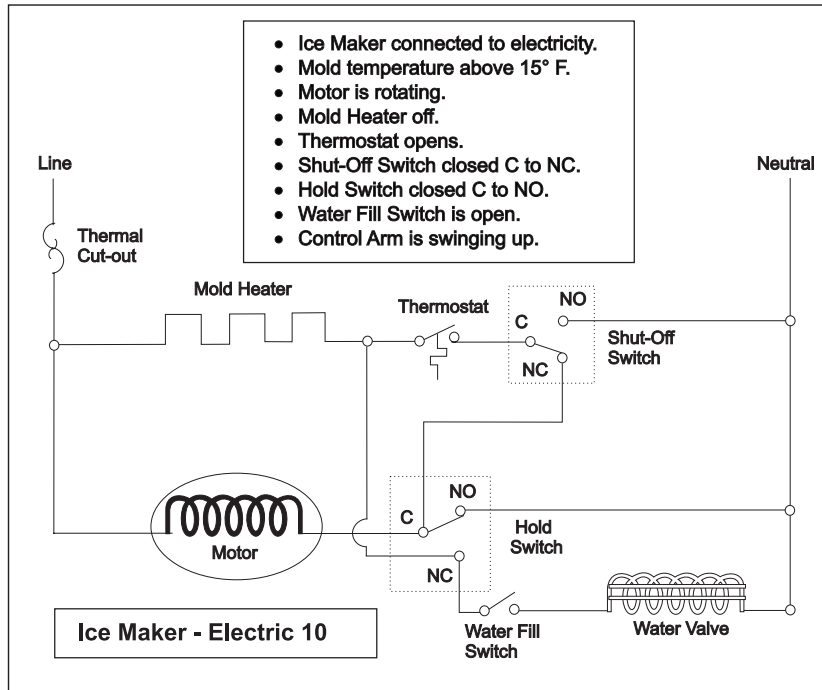

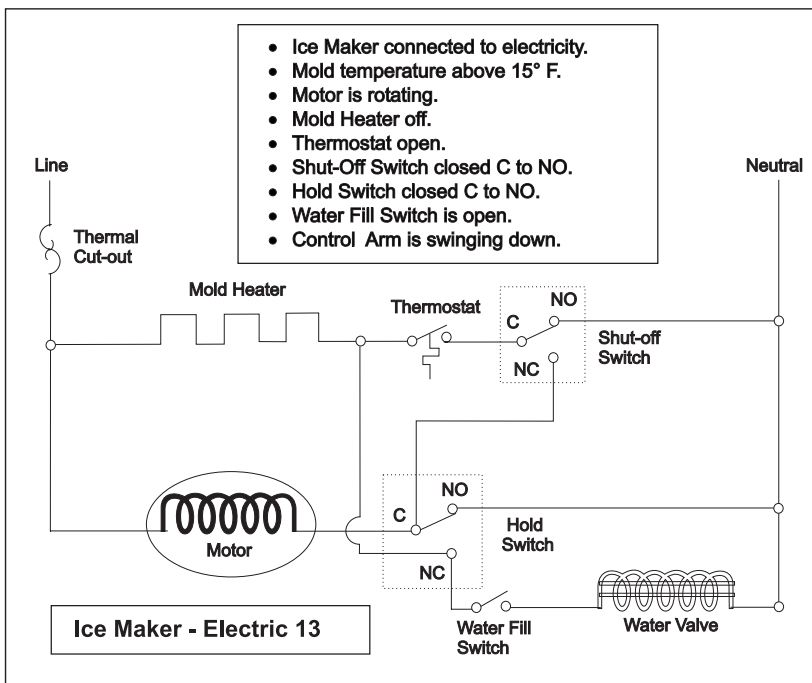
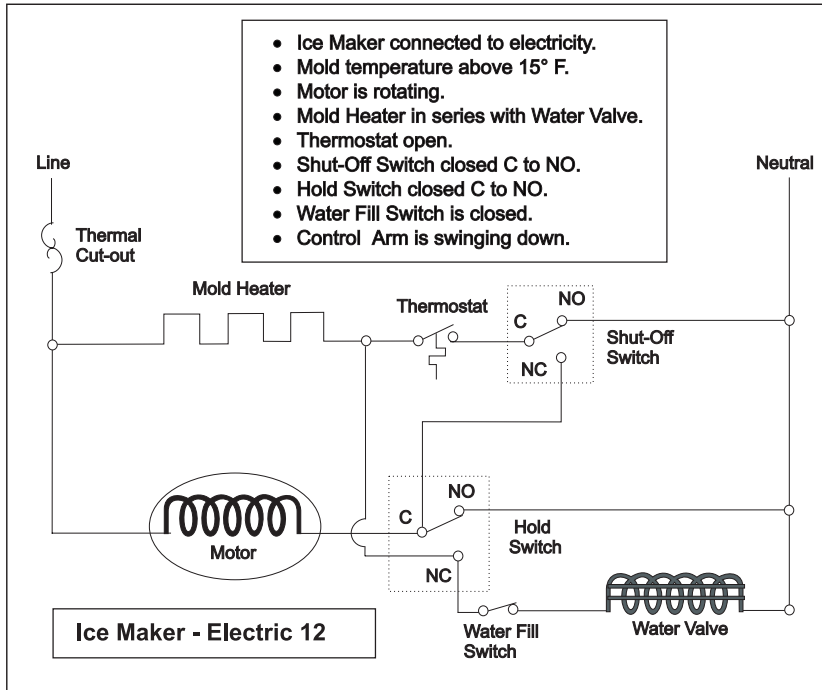

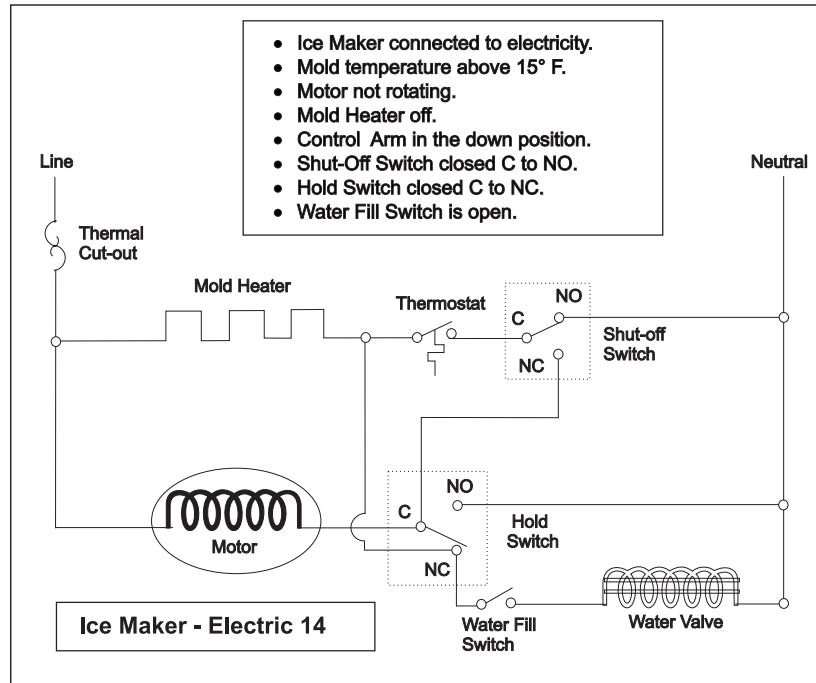

Operating Cycle Illustrations - Mechanical

The following Figures illustrate the mechanical operation of an Ice Maker.

Step 1

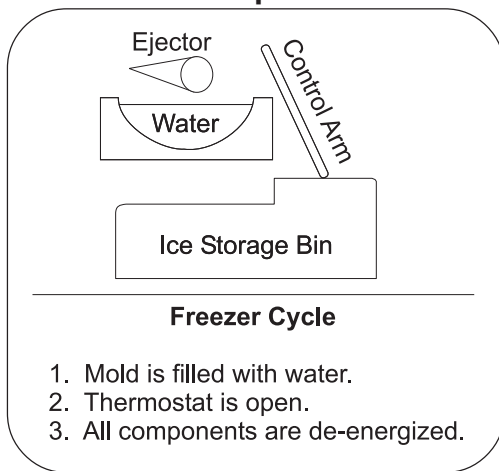

Step 2

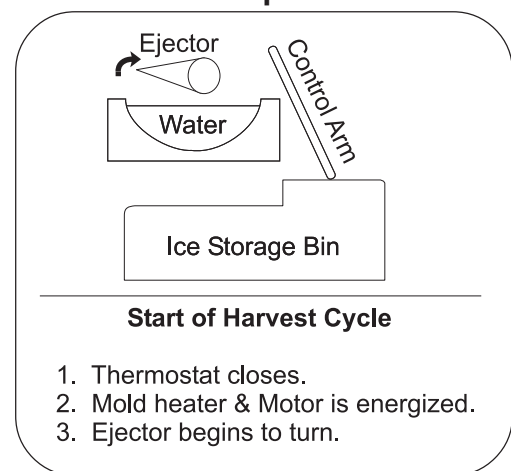

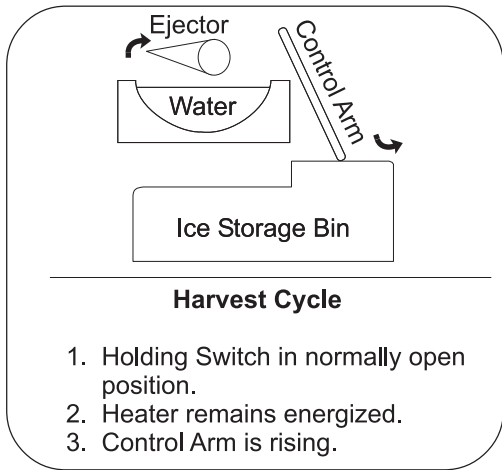

Step 3

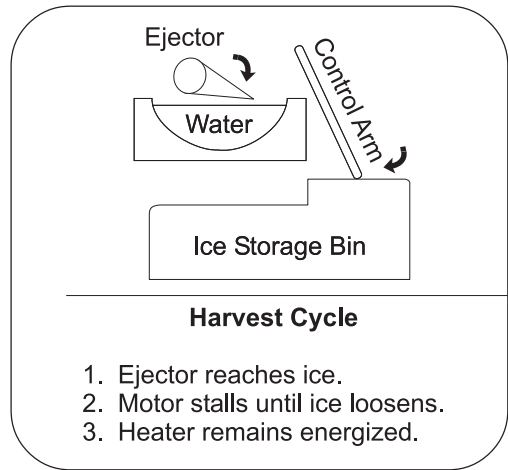

Step 4

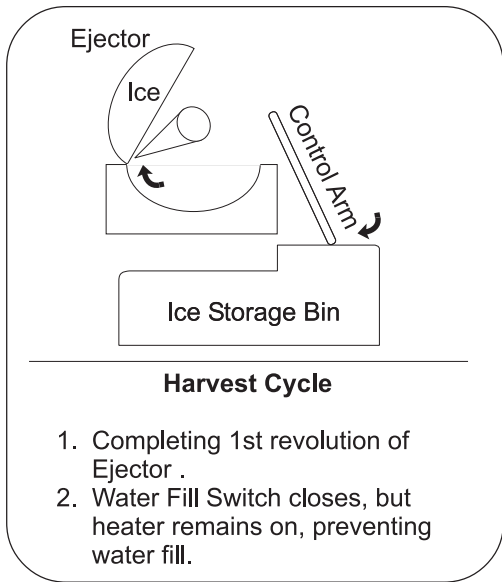

Step 5

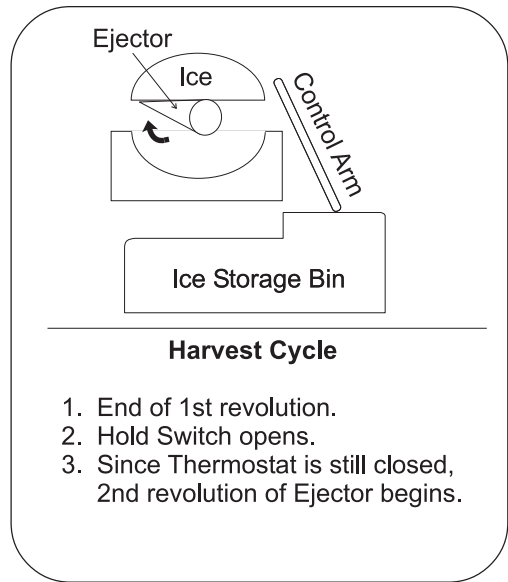

Step 6

Step 7

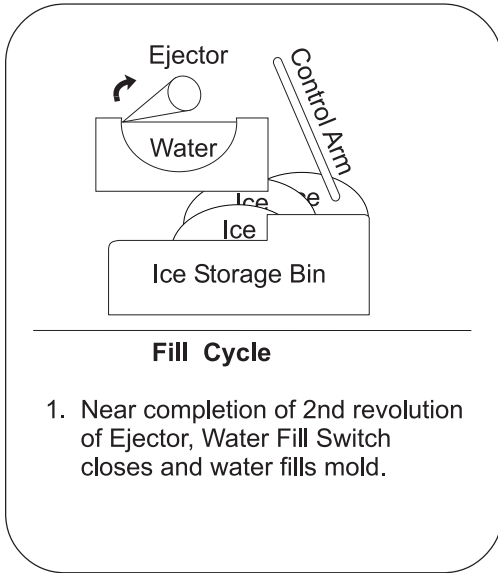

Step 8

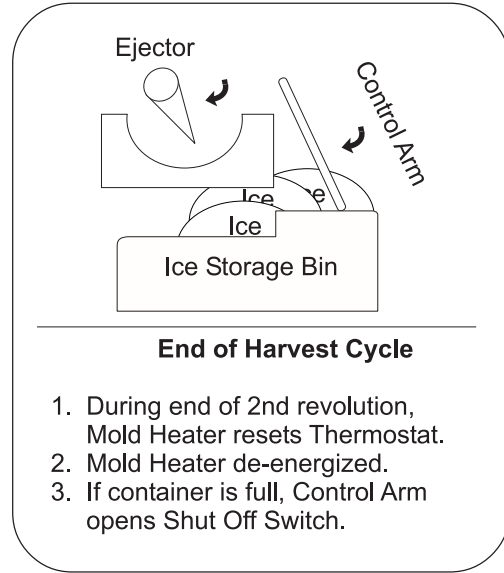

Step 9

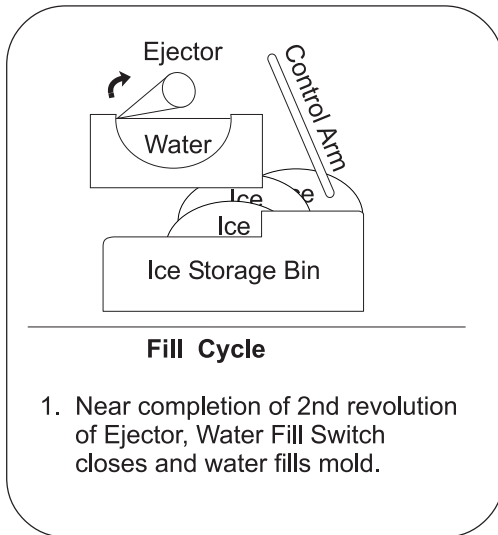

Step 10

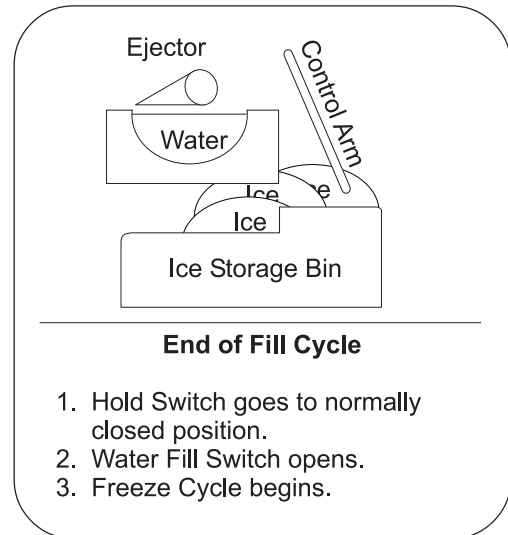

Ice Maker (Exploded View)

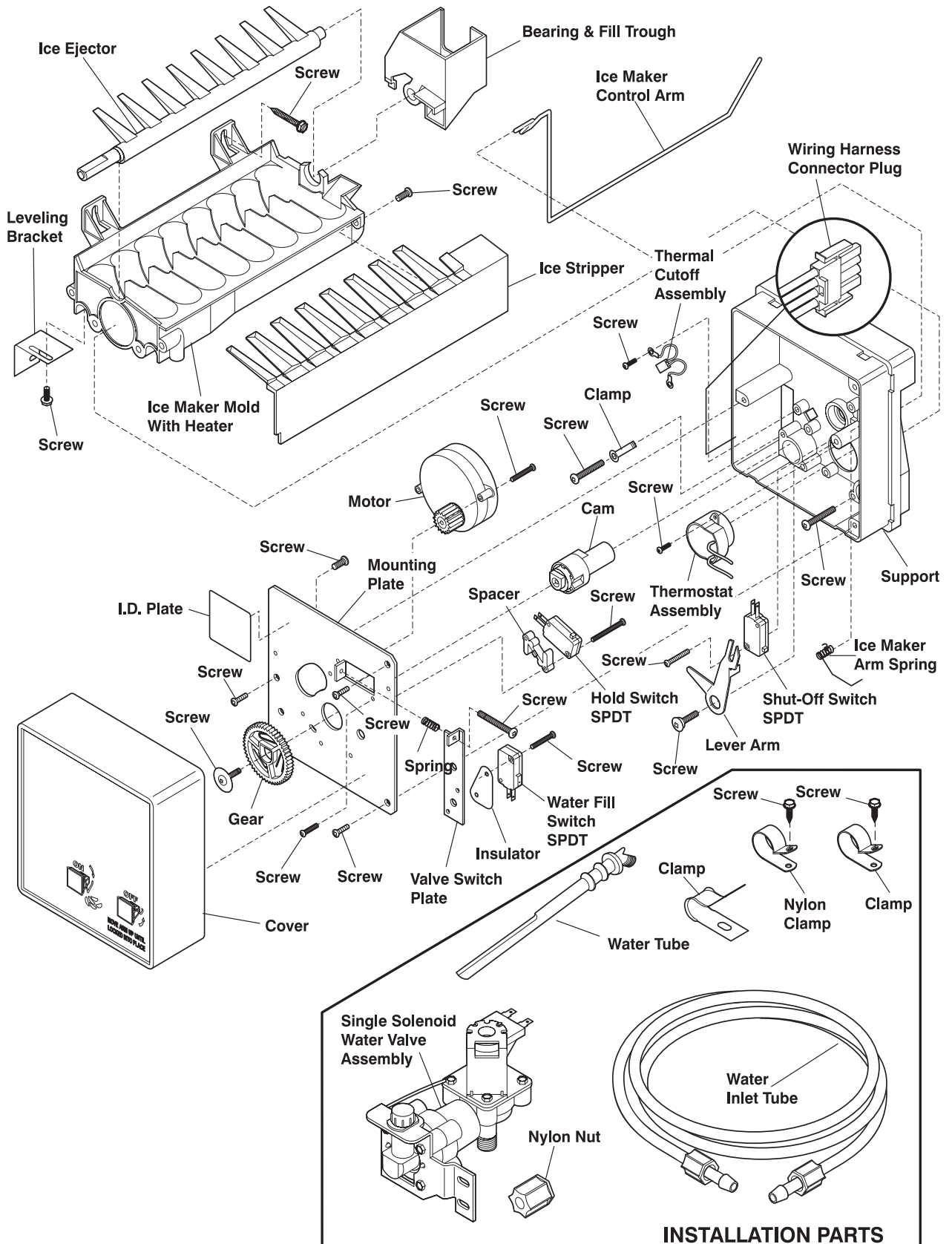

IMPORTANT SAFETY NOTICE

The information provided herein is designed to assist qualified repair personnel only. Untrained persons should not attempt to make repairs due to the possibility of electrical shock. Disconnect power cord before servicing.

IMPORTANT

If any green grounding wires are moved during servicing, they must be returned to their original position and properly secured.

CAUTION: System parts must be removed from cabinet before brazing. All electrical parts and wiring must be shielded from torch flame. Do not allow torch to contact insulation; it will char at 200°F and flash ignite (burn) at 500°F. Excessive heat will distort the plastic liner.

PERFORMANCE DATA NO LOAD AND NO DOOR OPENINGS AT MID-POINT CONTROL SETTING

Type A With Run/Start Capacitor	65°F (18°C) Ambient	90°F (32°C) Ambient
Operating Time	25 to 35%	45 to 55%
Freezer Temperature	2° to 8°F -17° to -13°C	0° to 5°F -18° to -15°C
Refrigerate Temperature	35° to 40°F 2° to 4°C	35° to 40°F 2° to 4°C
Low Side Pressure (cut-in)	8 to 16 psig 55 to 110 kPa	8 to 16 psig 55 to 110 kPa
Low Side Pressure (cut-out)	1 to 4 psig 7 to 28 kPa	1 to 4 psig 7 to 28 kPa
High Side Pressure (Last 1/3 of cycle)	110 to 120 psig 758 to 827 kPa	150 to 175 psig 1034 to 1207 kPa
Wattage (Last 1/3 of cycle)	140 to 185	140 to 185
Amps (Running)	1.1 to 1.6	1.1 to 1.6
Base Voltage	115 VAC	115 VAC

DEFROST SPECIFICATIONS

Cabinet Size	Thermostat		Heater	
	Cut-in	Cut-out	Watts	Ohms
18"	25°F -4°C	47°F 8°C	375	35

Defrost 30 Minutes Every 10 Hours of Compressor Run Time

CONDENSER FAN MOTOR

Watts	RPM	Amps
2.3	1300 CW Opposite Shaft	.15 Running

ICE MAKER SPECIFICATIONS

Electrical	115 Volts	60 Hertz
Thermostat	Opens at 48°F (9°C)	Closes at 15°F (-9°C)
Heater Wattage	165	

ICE MAKER CONNECTOR PLUG CONNECTIONS

Wire Number	Wire Color	Connects to:
1	Green/Yellow	Ground
2	Light Blue	Water Valve
3	Black	Line
4	Yellow	Neutral

SERVICE DATA SHEET - 240379001

R134a STANDARD - AUTOMATIC DEFROST TOP FREEZER MODELS (Dynamic Condenser)

ICE MAKER INFORMATION

Test Cycling

Remove cover by inserting screwdriver in notch at bottom and prying cover from housing. Use screwdriver to rotate motor gear counterclockwise until holding switch circuit is completed. All components of ice maker should function to complete the cycle.

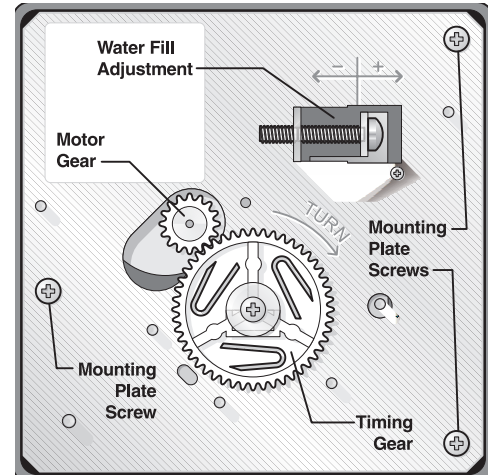

Water Fill Volume

The water fill adjustment screw will change the fill time. One full turn is equal to 20cc (.68 oz.). The correct fill is 90 to 120cc (3.0 to 4.0 oz.). The correct fill time is 6.9 sec. (+.6, -.4 sec) When a water valve is replaced, the fill volume must be checked.

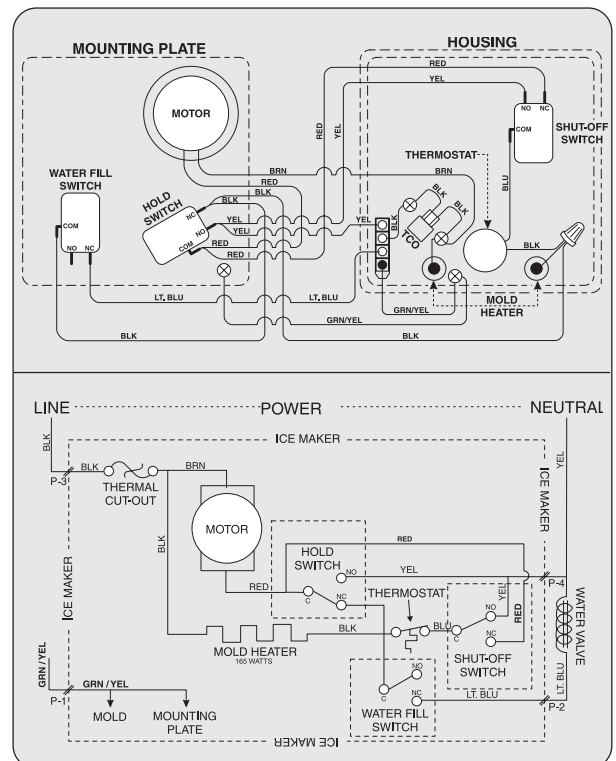

LADDER SCHEMATIC - TM DYNAMIC MODELS

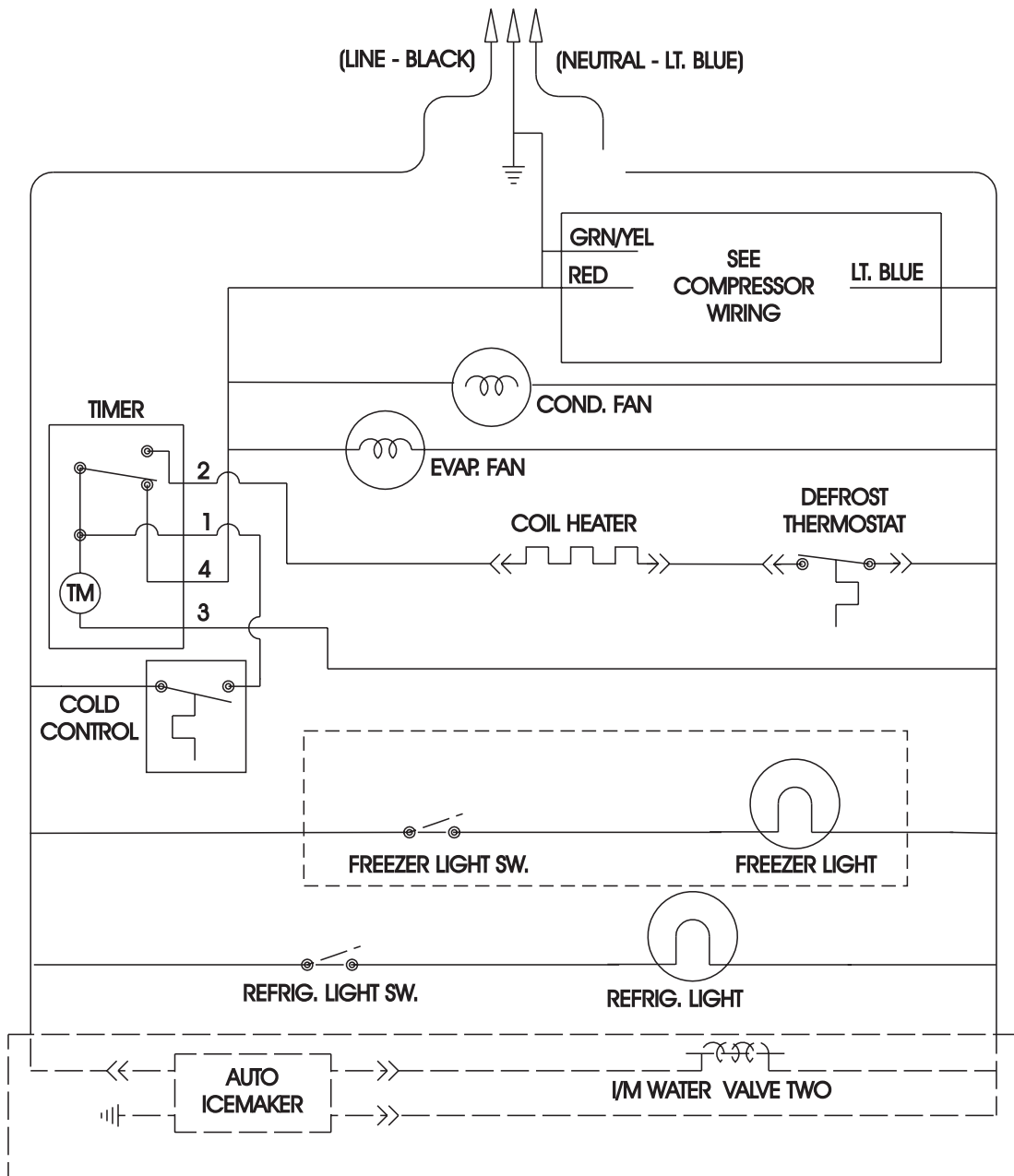

NOTE
 ----- DENOTES NOT ALL MODELS

Single Cold Control Thermostat using an Adaptive Defrost Control for defrost control.

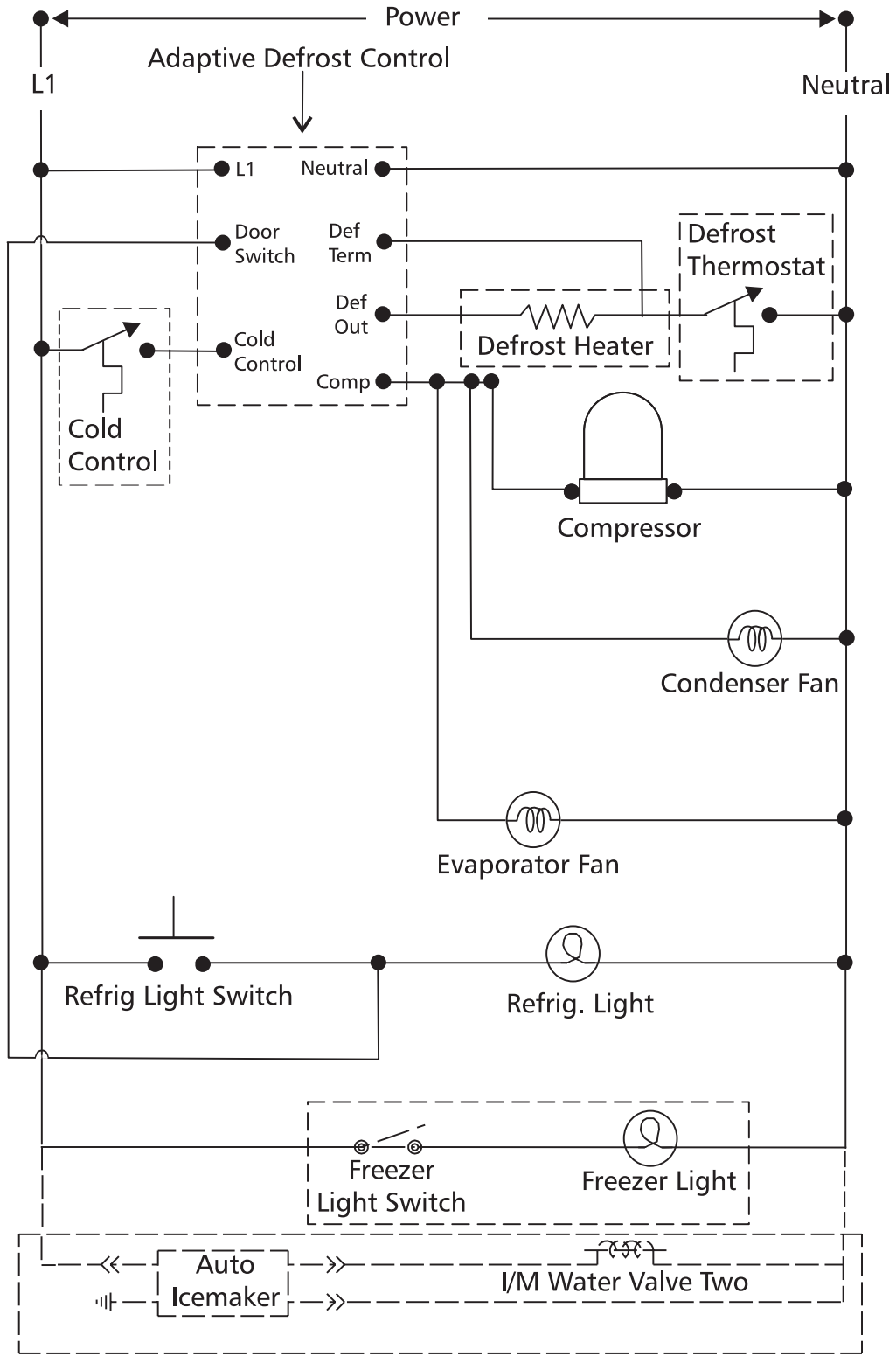

NOTE

----- Denotes Not All Models

Wiring Diagram

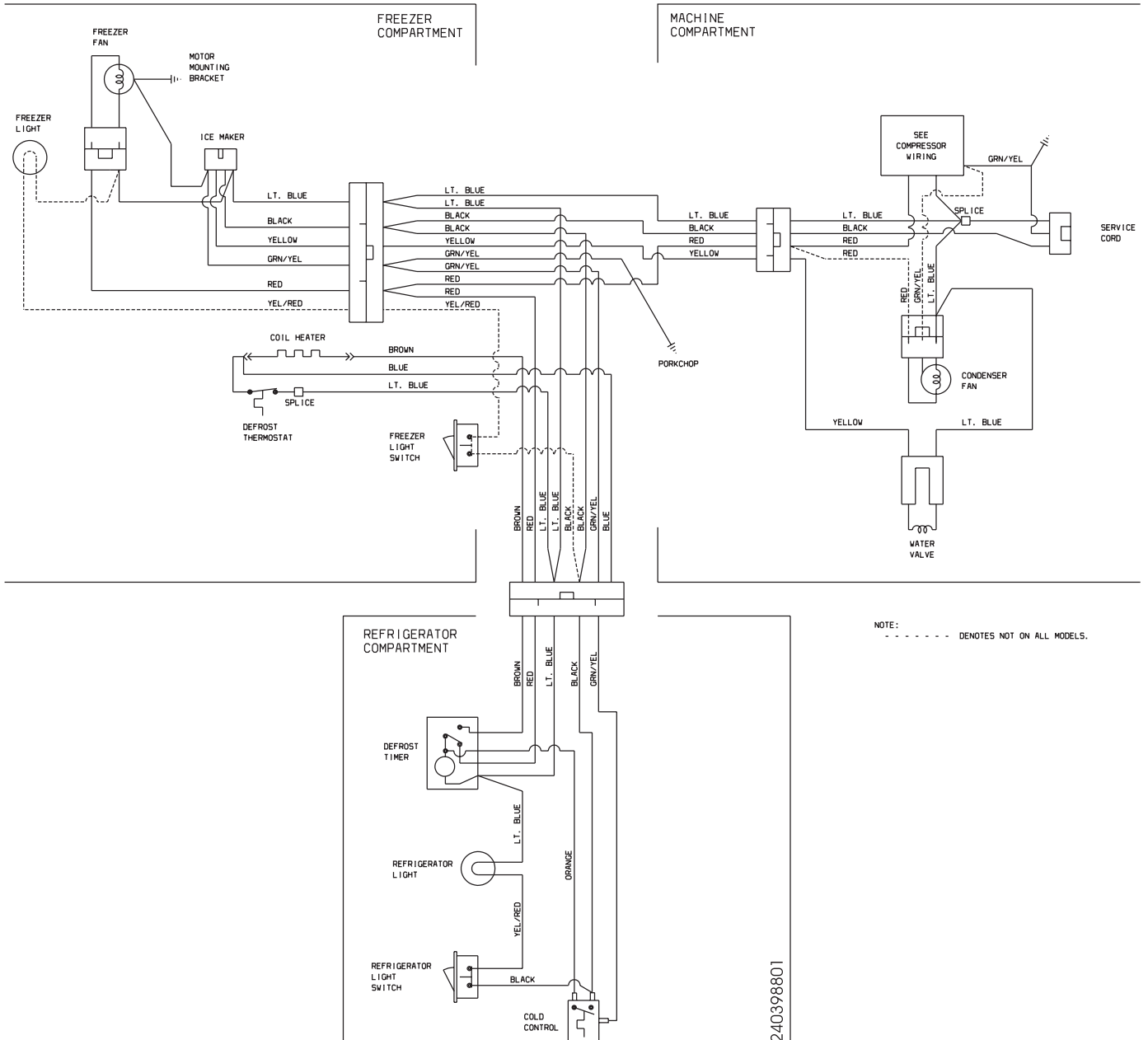

IMPORTANT SAFETY NOTICE

The information provided herein is designed to assist qualified repair personnel only. Untrained persons should not attempt to make repairs due to the possibility of electrical shock. Disconnect power cord before servicing.

IMPORTANT

If any green grounding wires are moved during servicing, they must be returned to their original position and properly secured.

CAUTION: System parts must be removed from cabinet before brazing. All electrical parts and wiring must be shielded from torch flame. Do not allow torch to contact insulation; it will char at 200°F and flash ignite (burn) at 500°F. Excessive heat will distort the plastic liner.

PERFORMANCE DATA NO LOAD AND NO DOOR OPENINGS AT MID-POINT CONTROL SETTING

Type A With Run/Start Capacitor	65°F (18°C) Ambient	90°F (32°C) Ambient
Operating Time	25 to 35%	45 to 55%
Freezer Temperature	2° to 8°F -17° to -13°C	0° to 5°F -18°C to -15°C
Refrigerature Temperature	35° to 40°F 2° to 4°C	35° to 40°F 2° to 4°C
Low Side Pressure (cut-in)	8 to 16 psig 55 to 110 kPa	8 to 16 psig 55 to 110 kPa
Low Side Pressure (cut-out)	1 to 4 psig 7 to 28 kPa	1 to 4 psig 7 to 28 kPa
High Side Pressure (Last 1/3 of cycle)	110 to 120 psig 758 to 827 kPa	150 to 175 psig 1034 to 1207 kPa
Wattage (Last 1/3 of cycle)	140 to 185	140 to 185
Amps (Running)	1.1 to 1.6	1.1 to 1.6
Base Voltage	115 VAC	115 VAC

DEFROST SPECIFICATIONS

Cabinet Size	Thermostat		Heater	
	Cut-in	Cut-out	Watts	Ohms
18"	+25°F -4°C	+47°F 8°C	375	35

Defrost 30 Minutes Every 10 Hours of Compressor Run Time

CONDENSER FAN MOTOR

Watts	RPM	Amps
2.3	1300 CW Opposite Shaft	.15 Running

ICE MAKER SPECIFICATIONS

Electrical	115 Volts	60 Hertz
Thermostat	Opens at 48°F (9°C)	Closes at 15°F (-9°C)
Heater Wattage	165	

ICE MAKER MOLEX PLUG CONNECTIONS

Wire Number	Wire Color	Connects to:
1	Green/Yellow	Ground
2	Light Blue	Water Valve
3	Black	Line
4	Yellow	Neutral

SERVICE DATA SHEET - 240379002

R134a

STANDARD - AUTOMATIC DEFROST TOP FREEZER MODELS

(Static Condenser)

ICE MAKER INFORMATION

Test Cycling

Remove cover by inserting screwdriver in notch at bottom and prying cover from housing. Use screwdriver to rotate motor gear counterclockwise until holding switch circuit is completed. All components of ice maker should function to complete the cycle.

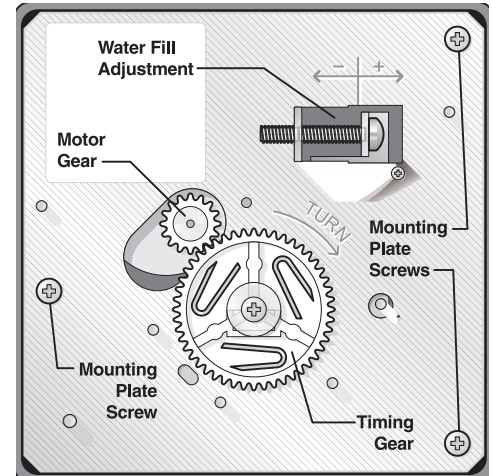

Water Fill Volume

The water fill adjustment screw will change the fill time. One full turn is equal to 20cc (.68 oz.). The correct fill is 90 to 120cc (3.0 to 4.0 oz.). The correct fill time is 6.9 sec. (+.6, -.4 sec) When a water valve is replaced, the fill volume must be checked.

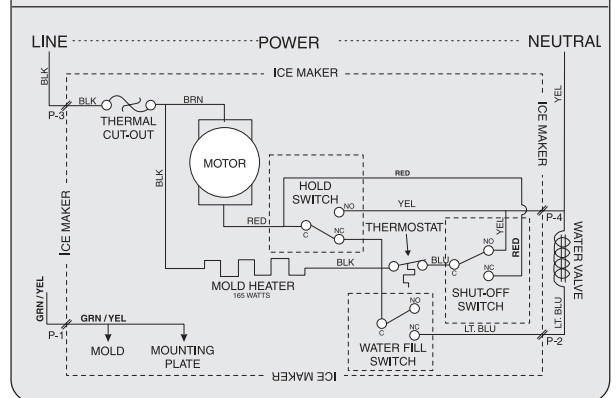
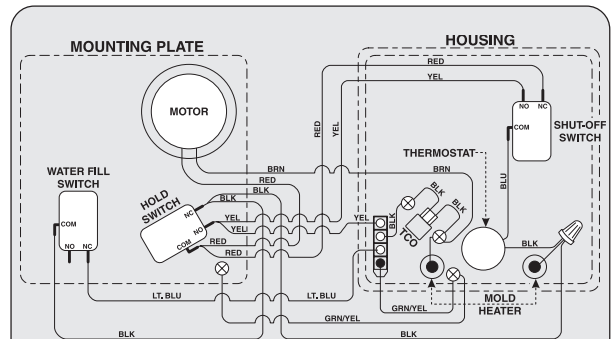

LADDER SCHEMATIC - TM STATIC MODELS

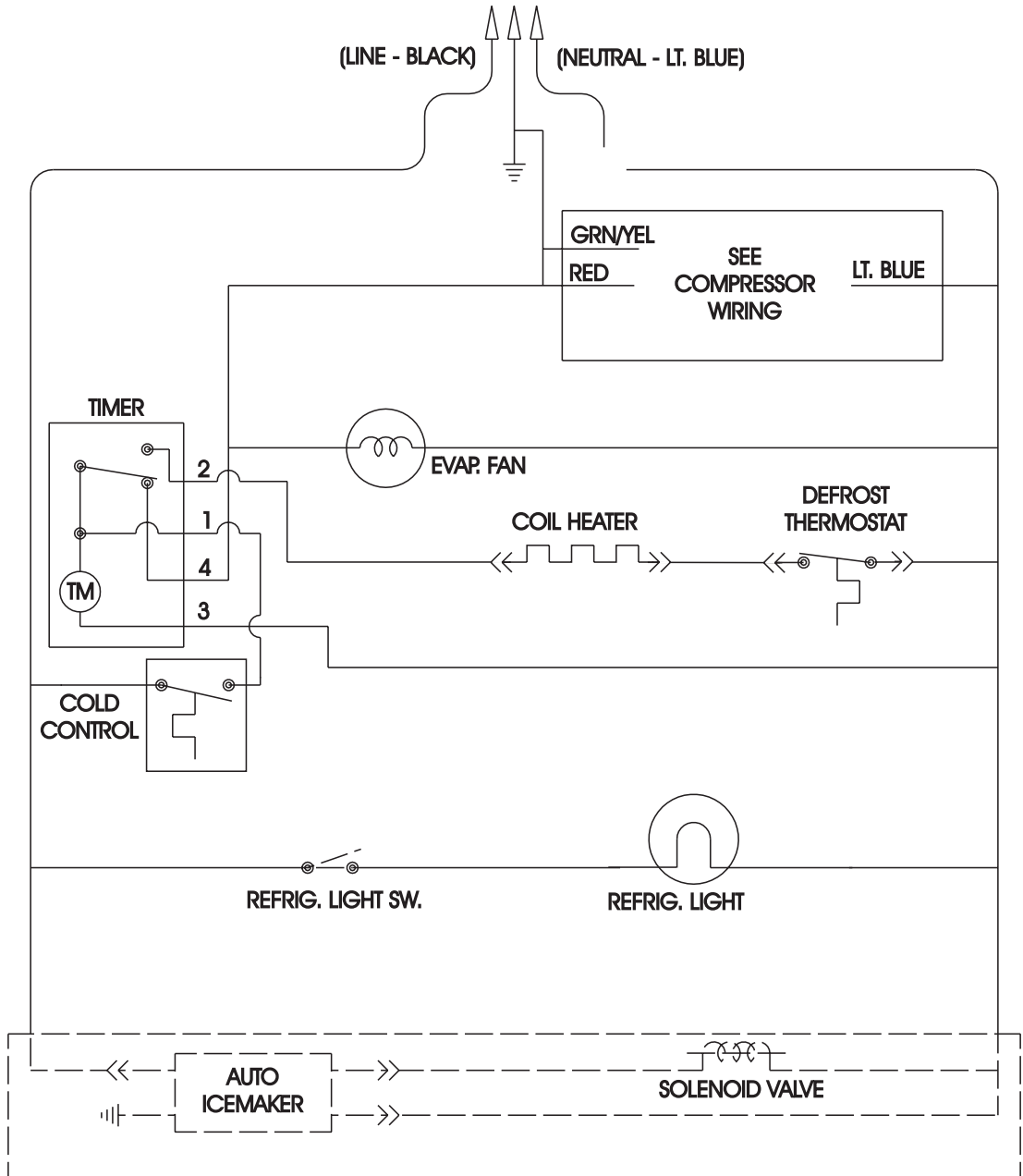

NOTE
 ----- DENOTES NOT ALL MODELS

Ice Maker Wiring Diagrams (Enlarged view)

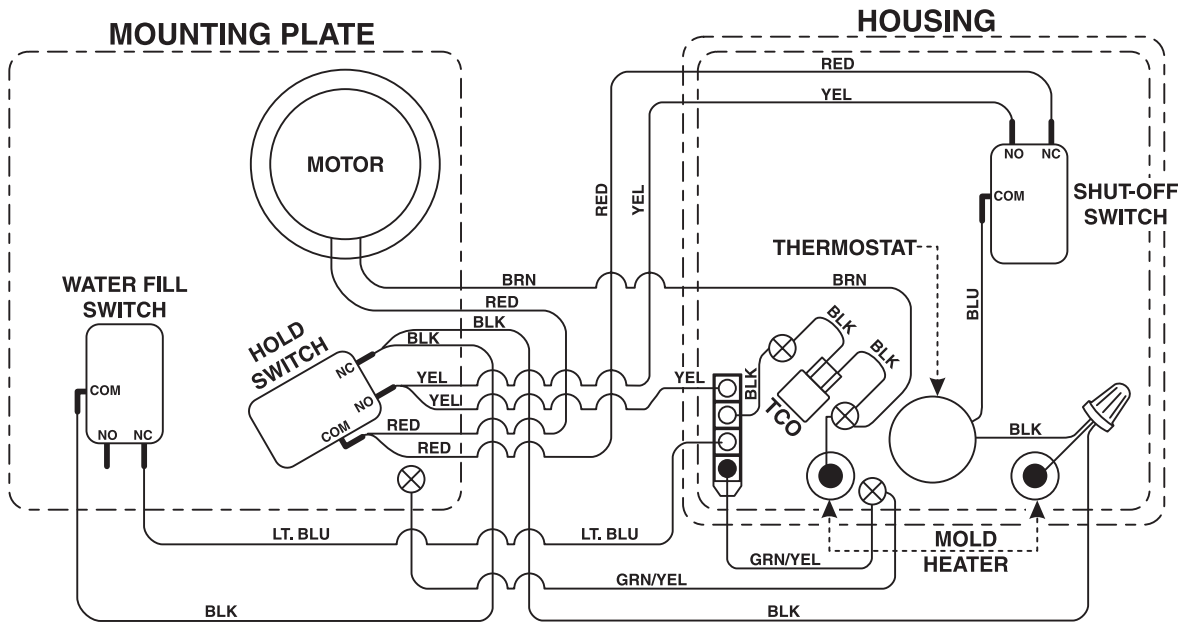
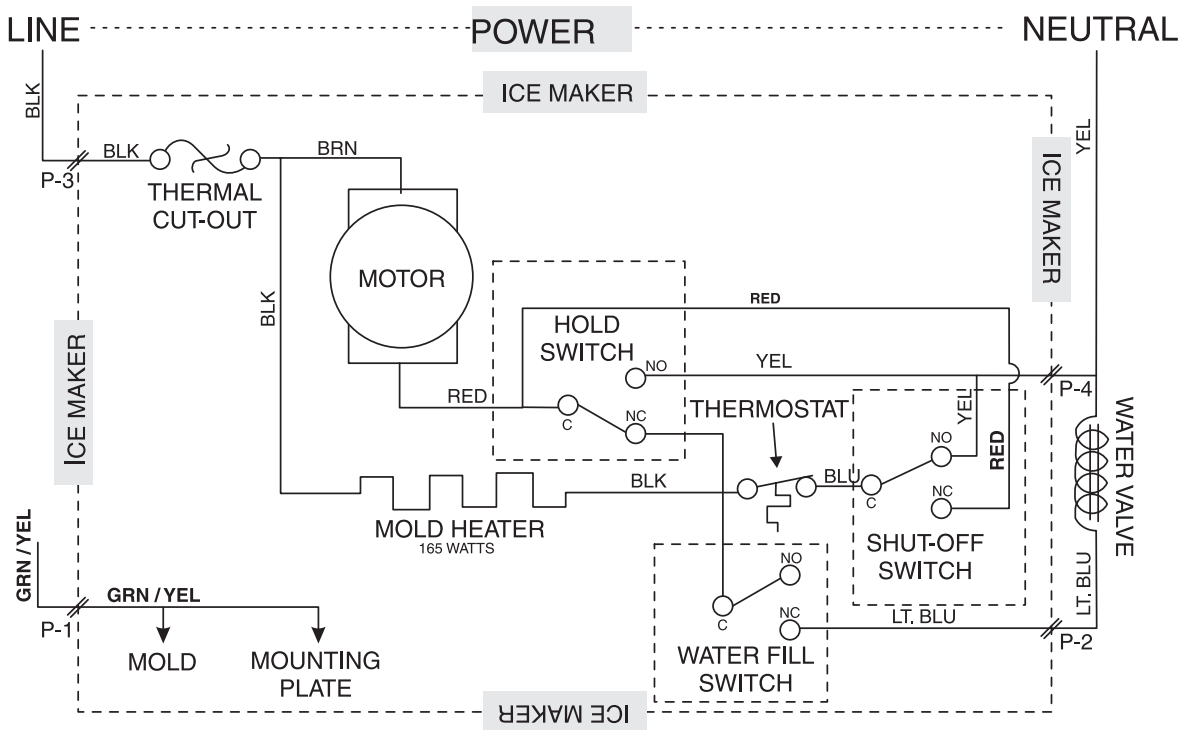

ICE MAKER INSTALLATION INSTRUCTIONS

⚠ WARNING To avoid electric shock, which can cause death or severe personal injury, disconnect the refrigerator from electrical power before connecting a water supply line to the refrigerator.

⚠ CAUTION To Avoid Property Damage:

- Copper tubing is recommended for the water supply line. Water supply tubing made of 1/4" plastic is not recommended since it greatly increases the potential for water leaks. The manufacturer will not be responsible for any damage if plastic tubing is used for the supply line.
- **DO NOT** install water supply tubing in areas where temperatures fall below freezing.
- Connect the ice maker to a drinkable water source that is not tied into a water softening system. Chemicals from the softener may damage the ice maker, causing it to malfunction.

The following items will be required to install the ice maker kit.

- 1/4 inch copper supply line with shut off valve
- 1/4 inch brass compression nut and ferrule
- Freezer shelf (Some models not equipped with shelf). If your model does not have one, contact your dealer to order one.

The copper tubing and shut off valve are available in a kit from your local hardware or plumbing supply store. Coil enough tubing at the back of the unit to allow movement for cleaning.

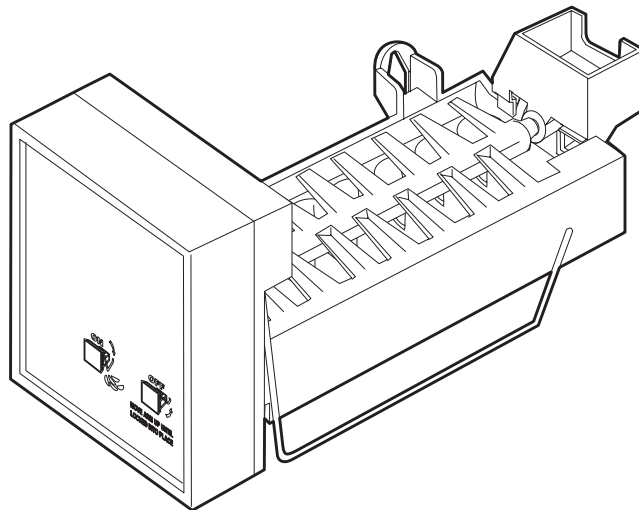

Use This Page to Identify Parts

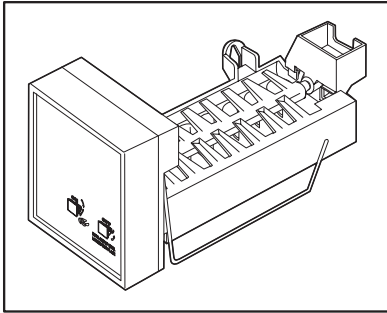

1. Ice Maker

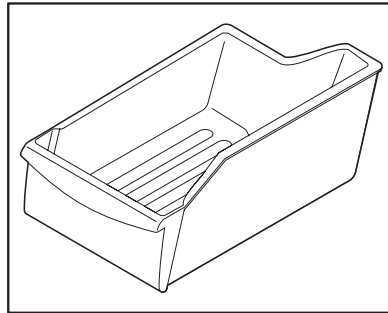

2. Ice Container

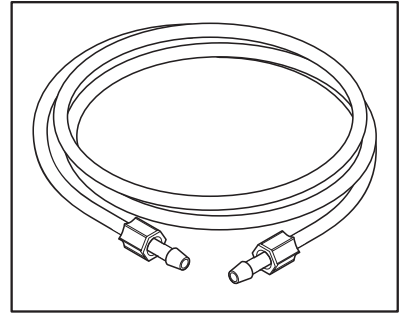

3. Plastic Water Supply Tubing

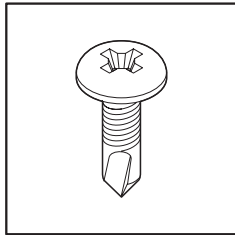

4. Screws - Qty 2

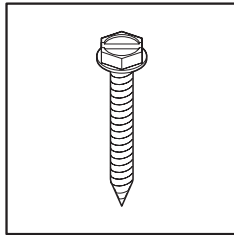

5. Screws - Qty 2

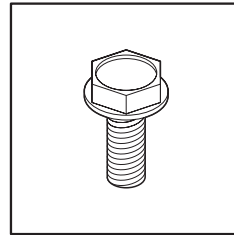

6. Leveling Bracket
Screw - Qty 1

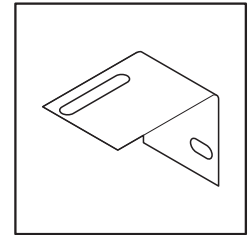

7. Leveling Bracket
Qty 1

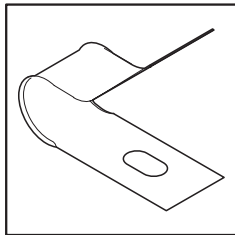

8. Steel Clamp - Qty 1

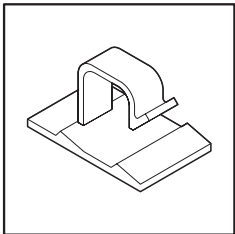

9. Plastic Clamp - Qty 2

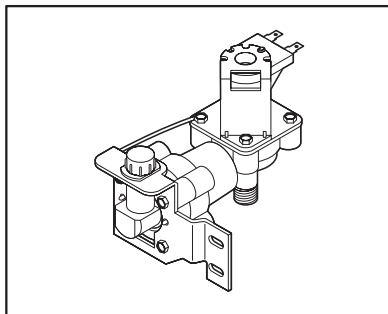

10. Water Valve - Qty 1

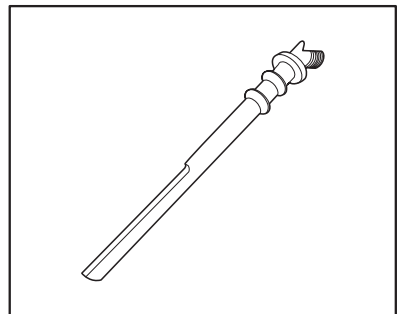

11. Water Inlet Tube - Qty 1

Tools Required:

- Putty Knife
- ¼ inch Socket Wrench or Nut Driver
- Knife
- Pliers
- Needle Nose Pliers
- Adjustable Wrench

1. Unplug refrigerator from wall outlet.
2. Remove ice tray rack from freezer (some models).
3. Remove freezer shelf (some models) by pushing shelf to left until right side of shelf is out of hole. Slowly lift up and pull on shelf to remove.
4. Remove plugs from inside freezer compartment with putty knife.

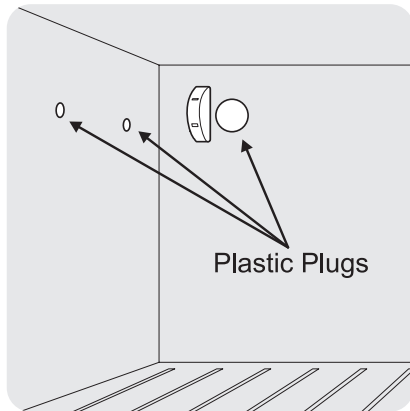

5. If refrigerator has exterior condenser (C), go to rear of refrigerator and locate left condenser mounting bracket screw(s). Remove and save screws. **DO NOT** remove compressor sound baffle (A), if installed. Carefully bend condenser out away from back of refrigerator. If condenser is mounted inside compressor compartment (D), remove screws securing sound baffle to cabinet (B).

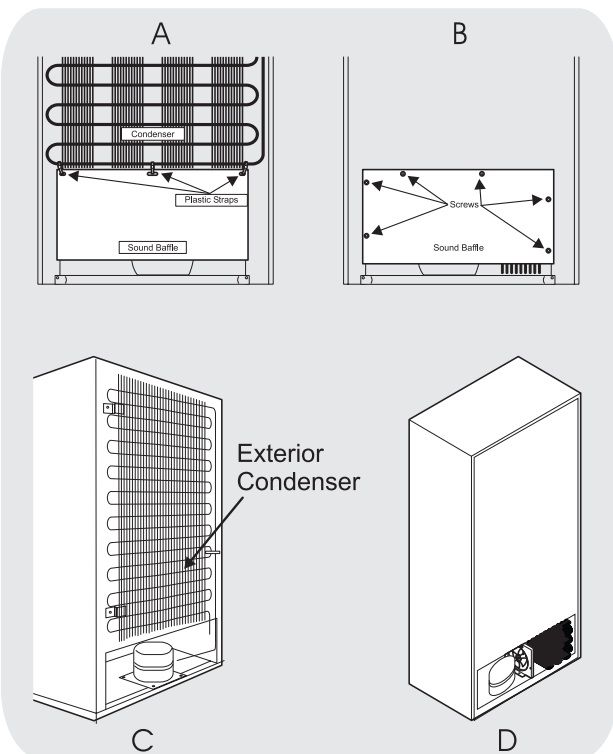

6. Peel off label covering ice maker hole.

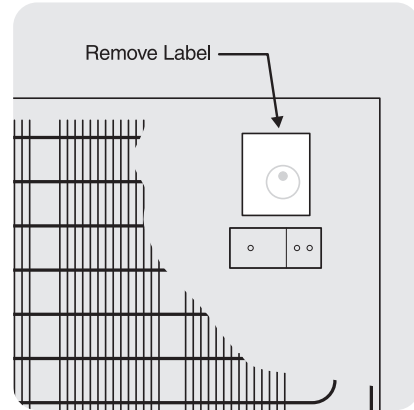

7. With needle nose pliers, remove foam from hole.

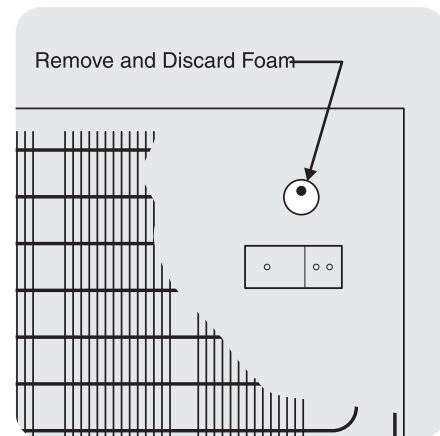

8. Push water inlet tube into small hole on back of refrigerator. Rotate while inserting tube until flat surface of inlet tube is tight against back of refrigerator.

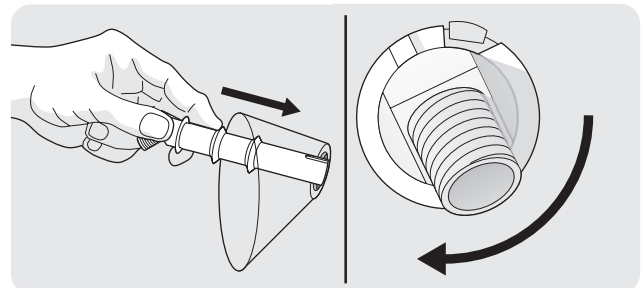

9. Push plastic water supply tubing (3) into water inlet tube (11) as far as it will go and finger tighten nylon compression nut onto threaded end of inlet tube. Tighten another one half turn with a wrench. **DO NOT** over tighten.

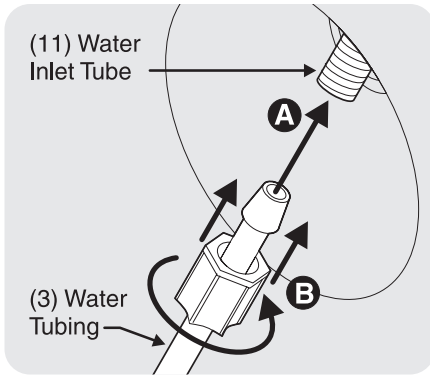

10. Install adjustable leveling bracket (7) on bottom of ice maker with screw (6). **DO NOT** tighten bracket. (Bracket will be tightened later.)

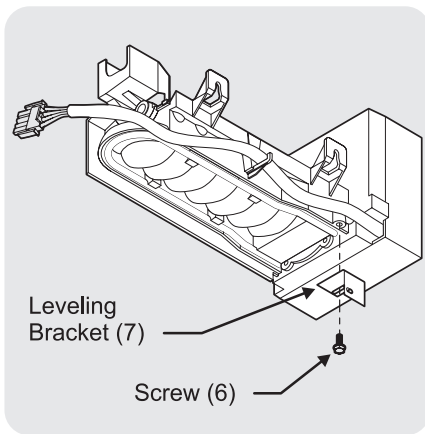

11. Start two, long, ice maker mounting screws (5) into freezer wall. Turn each screw five turns clockwise.

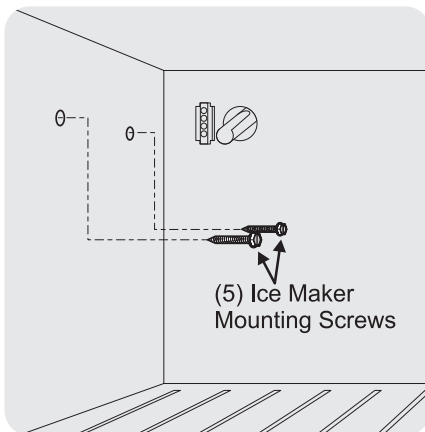

12. With ice maker in one hand, plug ice maker connector into connector mounted on back freezer panel. Make sure connection is tight.

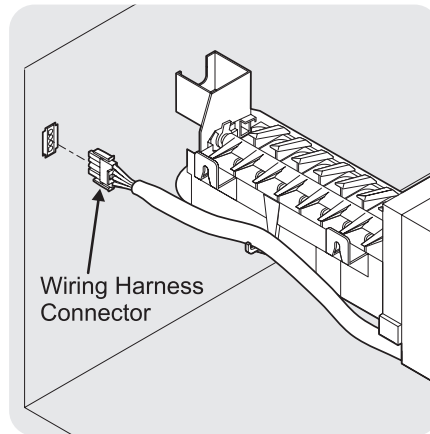

13. Mount ice maker onto two screws (5) you installed in Step 12. Tighten screws. Make sure water inlet tube (11) is sitting inside fill cup.

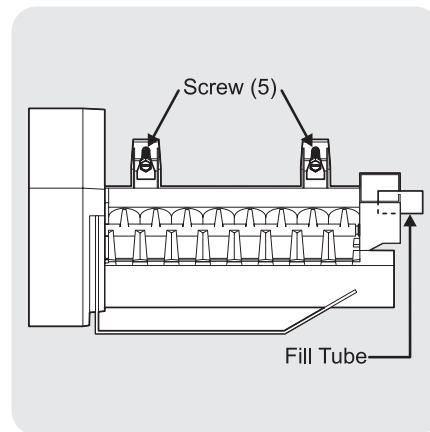

14. Adjust leveling bracket (7) to level ice maker (1). Ice maker is level when gap between freezer wall and ice maker is same at top and bottom. Tighten screw (6) when level.

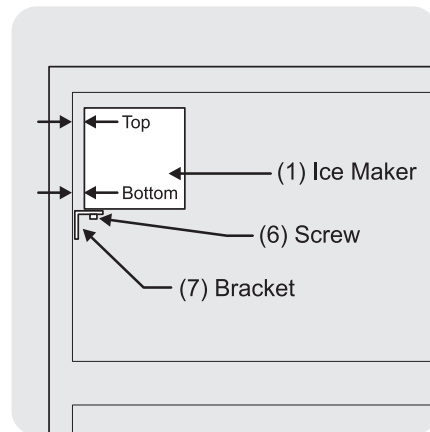

15. Reinstall freezer shelf in lower position. Set ice container (2) on shelf.

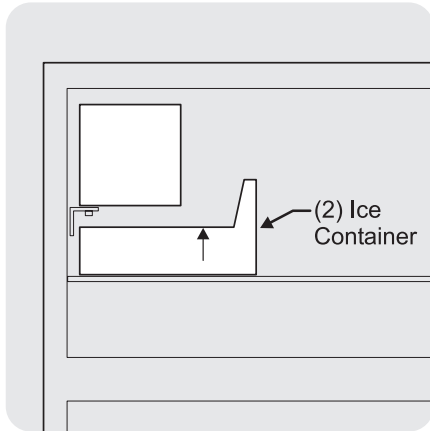

16. Locate factory punched holes at bottom right corner of rear panel. Holes are only drilled through cabinet liner. Align water valve bracket with factory drilled holes. Use a power drill with a Phillips® head bit to drive the two self drilling screws (4) through bracket and into cabinet.

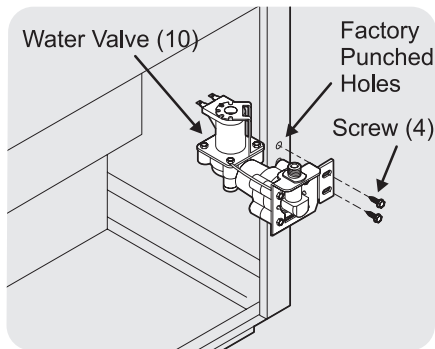

17. Connect wiring harness to water valve. Make sure connection is tight.

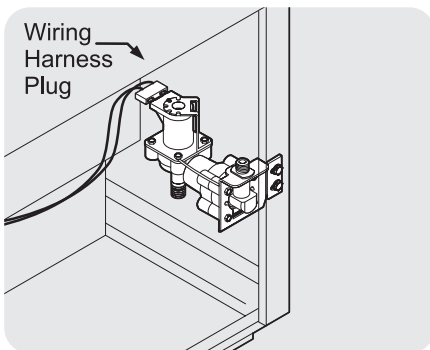

18. Push plastic water supply tubing into bottom of water valve as far as it will go. Finger tighten nylon compression nut onto threaded end of water valve. Tighten another one half turn with wrench. **DO NOT** overtighten.

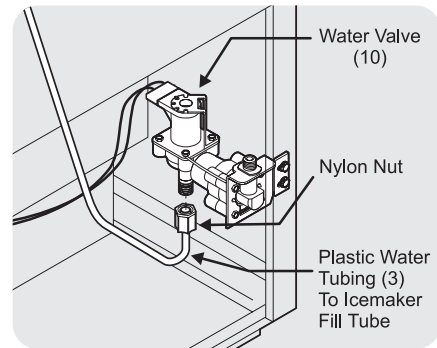

19. Secure plastic water tubing to rear of cabinet with two plastic clamps (9).

NOTE: Clean back of cabinet with a commercial household cleaner, ammonia or alcohol before applying clamps.

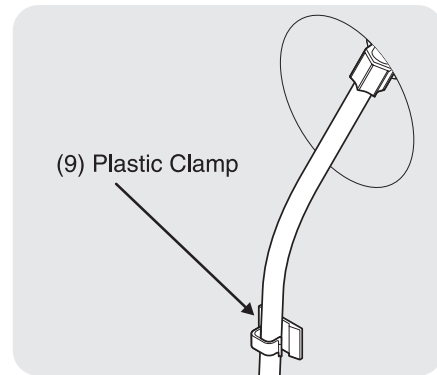

20. On models with exterior condenser, reinstall condenser brackets and tighten down screws.

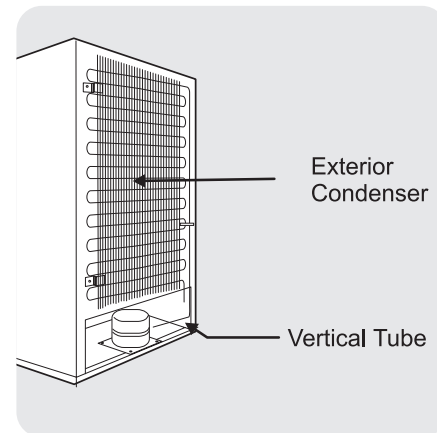

21. On refrigerators with dynamic condensers, remount sound baffle, if installed. See step 5.

Connecting Ice Maker to Water Supply

⚠ WARNING To avoid electric shock, which can cause death or severe personal injury, disconnect the refrigerator from electrical power before connecting a water supply line to the refrigerator.

⚠ CAUTION To Avoid Property Damage:

- Copper tubing is recommended for the water supply line. Water supply tubing made of 1/4 inch plastic is not recommended since it greatly increases the potential for water leaks. Manufacturer will not be responsible for any damage if plastic tubing is used for supply line.
- **DO NOT** install water supply tubing in areas where temperatures fall below freezing.
- Connect the ice maker to a potable water source that is not tied into a water softening system. Chemicals from the softener may damage the ice maker, causing it to malfunction.

IMPORTANT: Ensure that your water supply line connections comply with all local plumbing codes.

Before Installing The Water Supply Line, You Will Need

- **Basic tools:** adjustable wrench, flat blade screwdriver, and Phillips™ screwdriver.
- Access to a household **cold water line** with water pressure between 20 and 120 psi.
- A water supply line made of 1/4 inch (6.4 mm) OD, copper tubing. To determine the length of copper tubing needed, you will need to measure the distance from the ice maker inlet valve at the back of the refrigerator to your cold water pipe. Then add approximately 7 feet (2.1 meters), so the refrigerator can be moved out for cleaning.
- A shutoff valve to connect the water supply line to your household water system. **DO NOT** use a self-piercing type shutoff valve.
- A compression nut and ferrule (sleeve) for connecting the water supply line to the ice maker inlet valve.

NOTE: Water line kit number 5303917950, available from your appliance dealer at additional cost, contains 25 feet (7.6 meters) of 1/4 inch OD copper tubing, a saddle type shutoff valve (nonpiercing), (2) 1/4 inch brass compression nuts, (2) ferrules/sleeves, and instructions for installing a water supply line.

To Connect Water Supply Line To Ice Maker Inlet Valve

1. Disconnect refrigerator from electric power supply.
2. Place end of water supply line into sink or bucket. Turn ON water supply and flush supply line until water is clear. Turn OFF water supply at shutoff valve.
3. Unscrew plastic cap from water valve inlet and discard cap.
4. Slide brass compression nut, then ferrule (sleeve), onto water supply line, as shown.
5. Push water supply line into water valve inlet as far as it will go (1/4 inch). Slide ferrule (sleeve) into valve inlet and finger tighten compression nut onto valve. Tighten another half turn with a wrench; **DO NOT** over tighten.
6. With steel clamp and screw, secure water supply line to rear panel of refrigerator at location as shown.
7. Coil excess water supply line (about 2-1/2 turns) behind refrigerator as shown and arrange coils so they do not vibrate or wear against any other surface.
8. Turn ON water supply at shutoff valve and tighten any connections that leak.
9. Reconnect refrigerator to electric power supply.
10. To turn ice maker on, lower wire signal arm. (See ice maker front cover for on/off position of arm.)

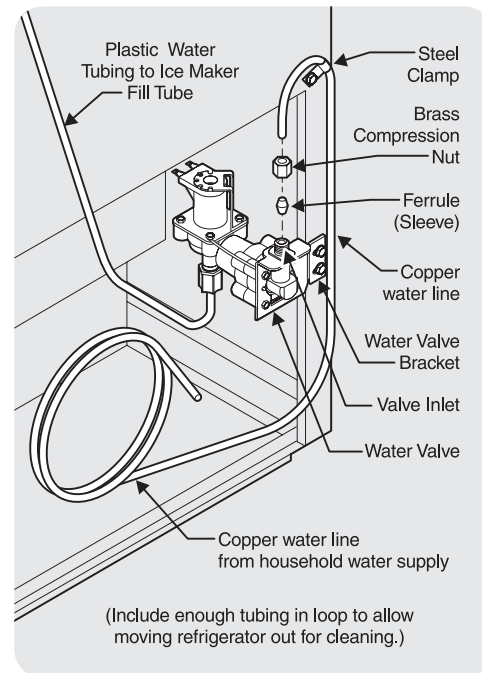

IMPORTANT: It takes approximately 24 hours for the ice maker to begin producing ice. Air in new plumbing lines may cause ice maker to cycle two or three times before making a full tray of ice. New plumbing may cause ice to be discolored or have poor flavor. Discard ice made during the first 24 hours.

Automatic Ice Maker Tips

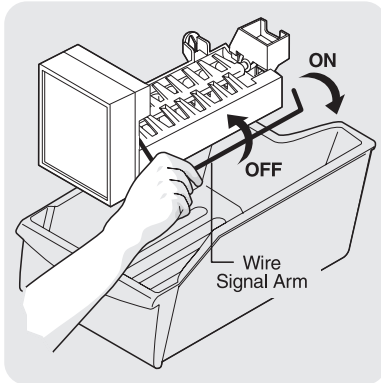

Remember that water quality determines your ice quality. Do not connect the ice maker to water that is softened. Chemicals from a malfunctioning softener can damage the ice maker.

To stop the ice maker, lift the wire signal arm until it clicks and locks in the "up" or OFF position. The ice maker turns off automatically when the ice container is full. If your model has an adjustable freezer shelf, place the shelf so the wire signal arm will hit the ice when the ice container is full.

Ice Maker Tips

- Ice stored too long may develop an odd flavor. Empty the container and be sure the wire signal arm is in its "down" or ON position. The ice maker will then produce more ice.
- Occasionally shake the container to keep ice separated.
- Keep the wire signal arm in its "up" or OFF position until the refrigerator is connected to the water supply or whenever the water supply is turned off.
- The following sounds are normal when the ice maker is operating.
 - Motor running
 - Ice loosening from tray
 - Ice dropping into ice container
 - Running water
 - Water valve opening or closing

CAUTION DO NOT place the ice container in your dishwasher.

- Wash ice container in warm water with mild detergent. Rinse well and dry.
- Stop the ice maker when cleaning the freezer or for short vacations.
- If the ice maker will be turned off for a long period of time, turn the water supply valve to the closed position.

System Diagram

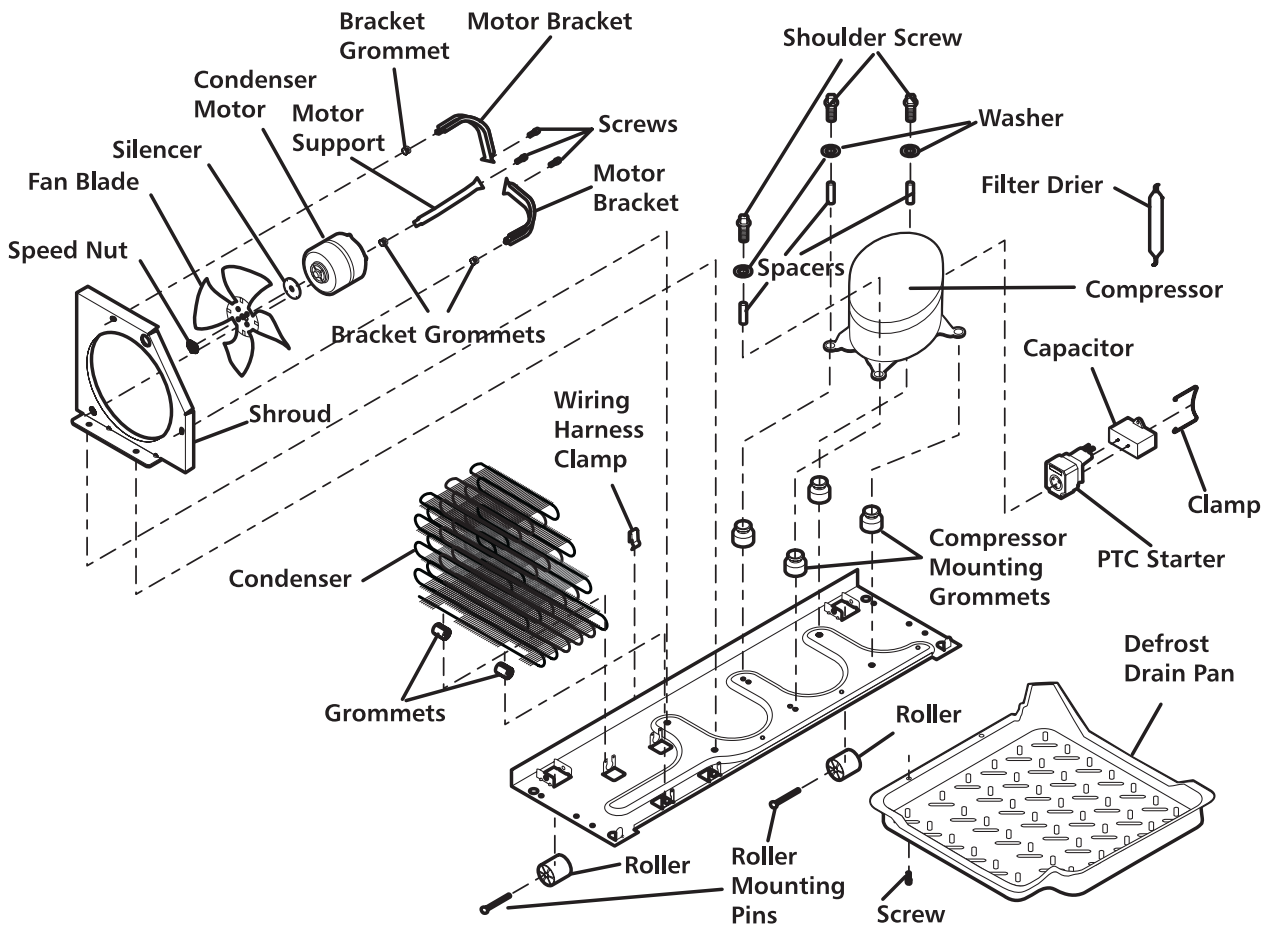
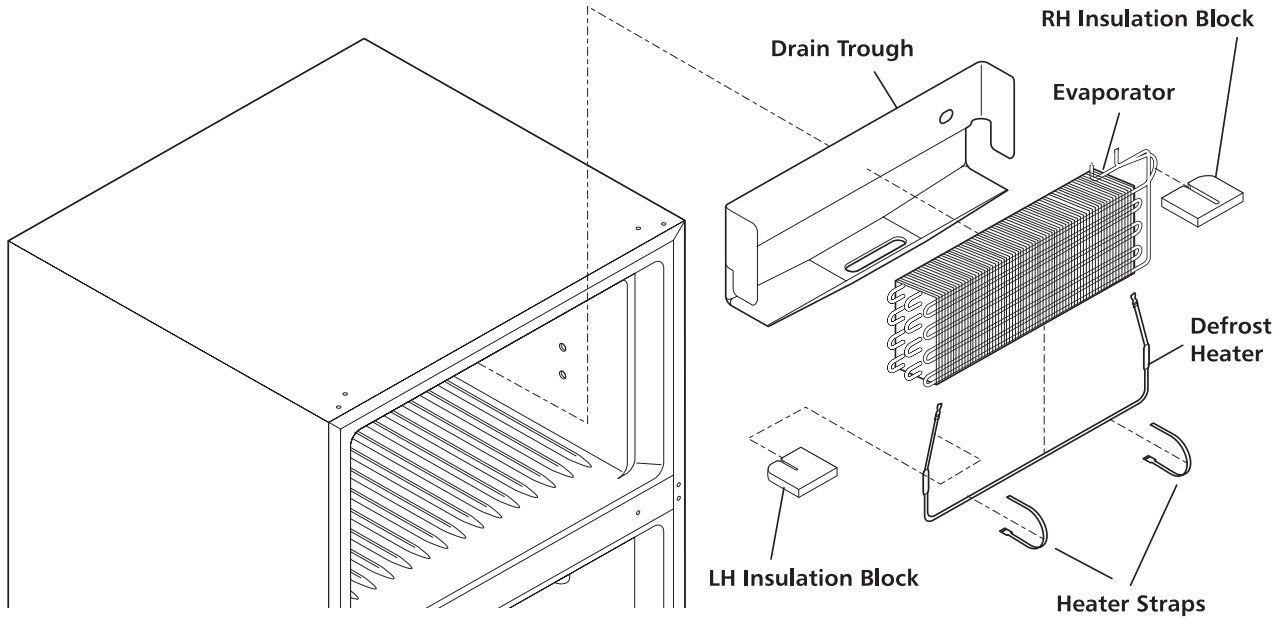

Cabinet Diagram

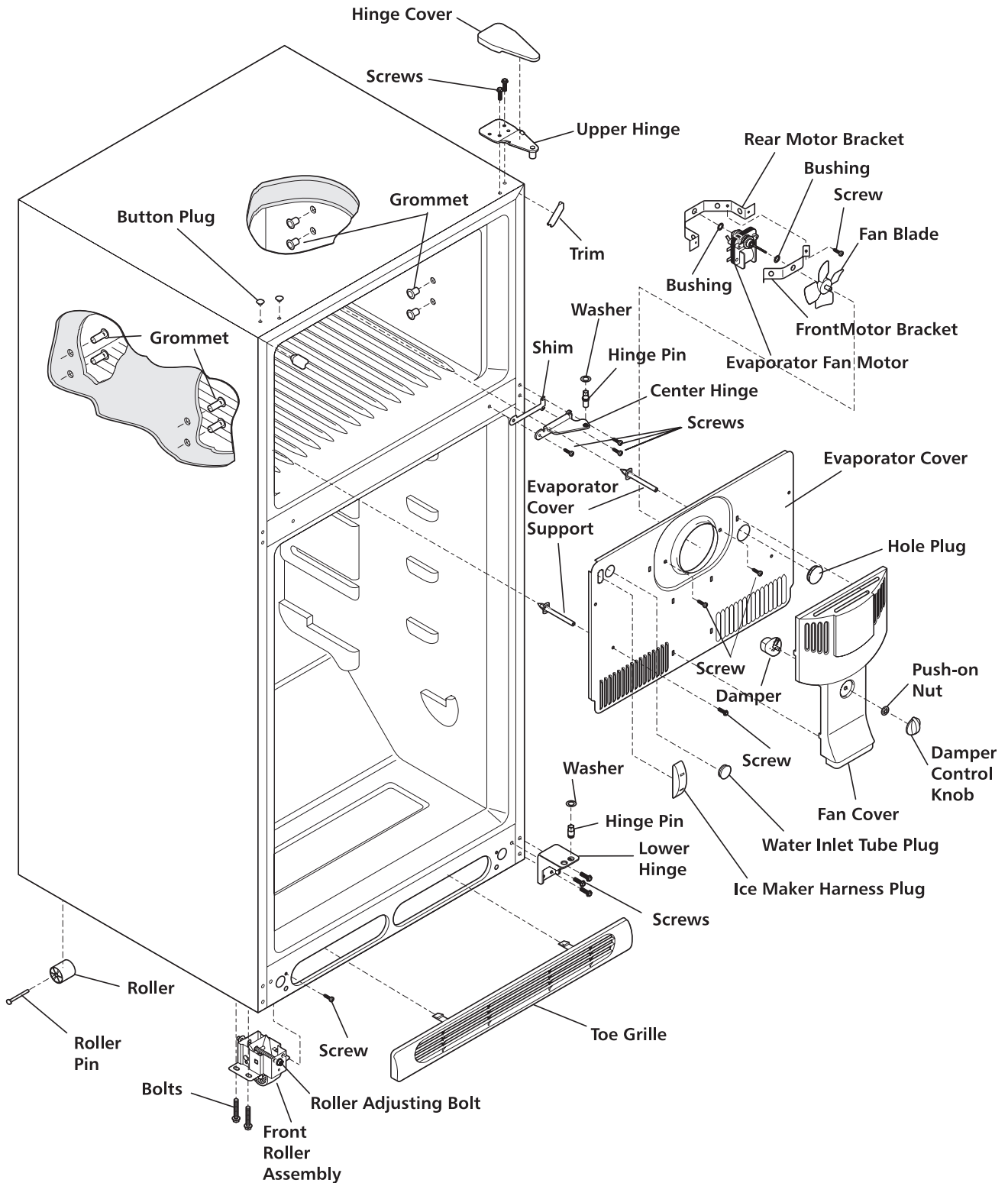

Doors Diagram

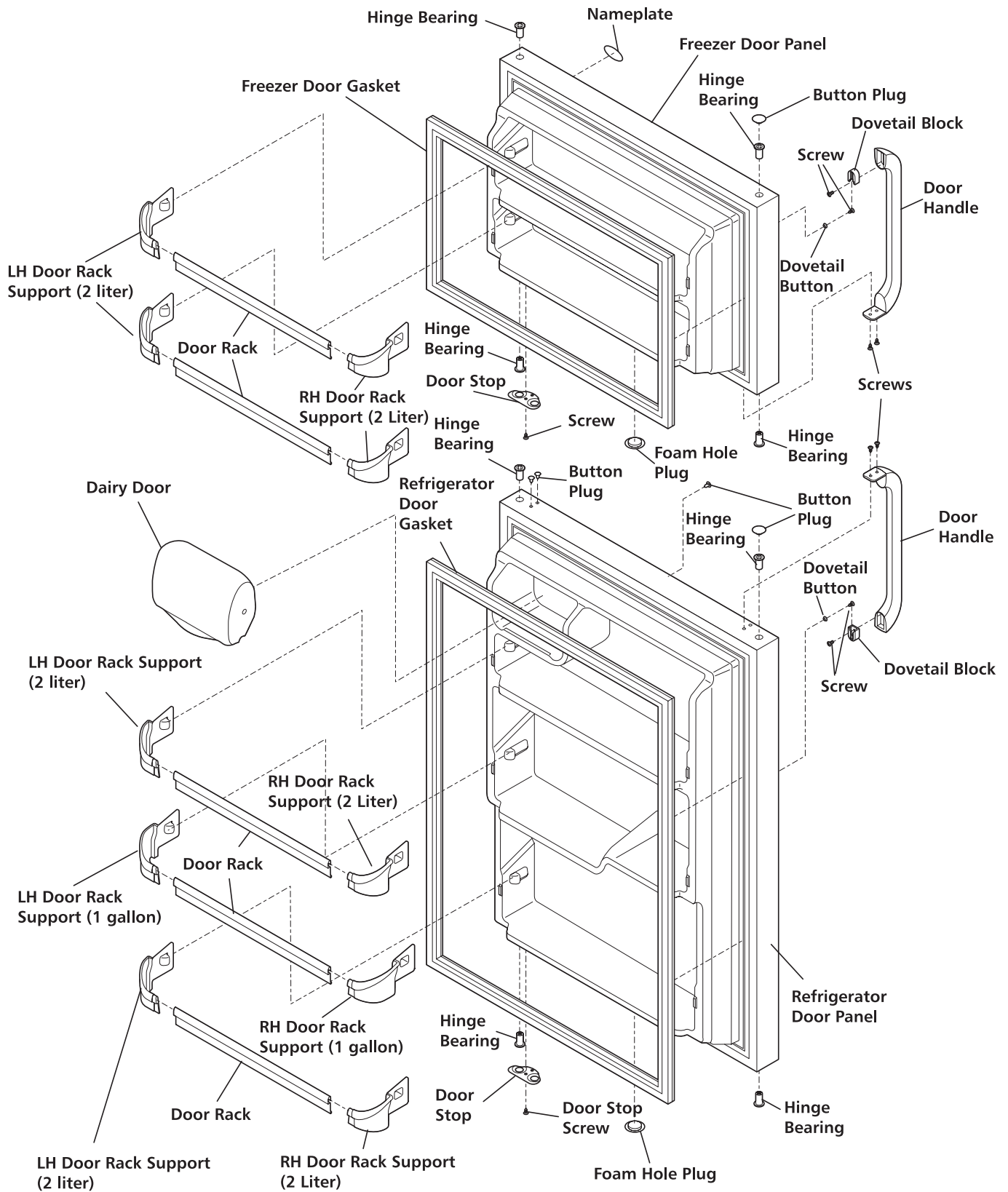

Evaporator Assembly Diagram

